

Operator's Manual

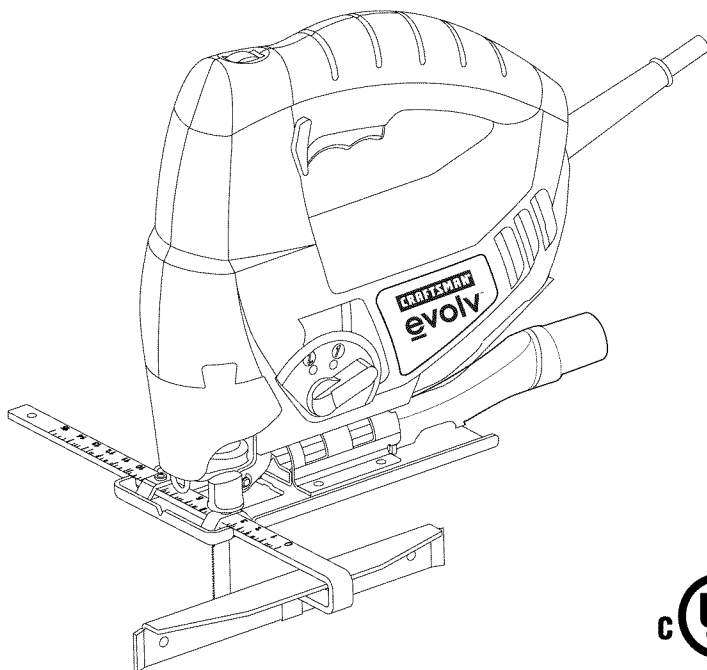

4.5 AMP JIGSAW

Model No. 320.17434



⚠ WARNING: To reduce the risk of injury, the user must read and understand the **Operator's Manual** before using this product.

- WARRANTY
- SAFETY
- ASSEMBLY
- DESCRIPTION
- OPERATION
- MAINTENANCE

Sears, Roebuck and Co., Hoffman Estates, IL 60179 U.S.A.

www.craftsman.com

TABLE OF CONTENTS

Warranty	page 2
Safety Symbols	page 3
Safety Instructions	page 4-9
Description	page 9-10
Assembly	page 10-11
Operation	page 12-14
Maintenance	page 15
Troubleshooting	page 15
Exploded View and Part List	page 16-17
Sears Repair Parts Phone Number	Back Cover

CRAFTSMAN EVOLV ONE YEAR FULL WARRANTY

If this Craftsman Evolv product fails due to a manufacturer's defect in material or workmanship within one year from the date of purchase, return it to any Sears store or other Craftsman Evolv outlet in the United States for free replacement.

This warranty does not cover the blade, which is an expendable part.

This warranty is void if this product is ever used for commercial or rental purposes.

This warranty gives you specific legal rights, and you may also have other rights which vary from state to state.

Sears, Roebuck and Co., Hoffman Estates, IL 60179

⚠ WARNING: Some dust created by using power tools contains chemicals known to the state of California to cause cancer and birth defects or other reproductive harm.

**SAVE THESE INSTRUCTIONS!
READ ALL INSTRUCTIONS!**

SAFETY SYMBOLS

The purpose of safety symbols is to attract your attention to possible dangers. The safety symbols and the explanations with them deserve your careful attention and understanding. The symbol warnings do not, by themselves, eliminate any danger. The instructions and warnings they give are no substitutes for proper accident prevention measures.

⚠ WARNING: Be sure to read and understand all safety instructions in this manual, including all safety alert symbols, such as **“DANGER,” “WARNING,”** and **“CAUTION,”** before using this keyless drill. Failure to following all instructions listed below may result in electric shock, fire and/or serious personal injury.

SYMBOL MEANNING

⚠ SAFETY ALERT SYMBOL: Indicates **DANGER, WARNING, OR CAUTION.** May be used in conjunction with other symbols or pictographs.

⚠ DANGER: Failure to obey this safety warning will result in death or serious injury to yourself or to others. Always follow the safety precautions to reduce the risk of fire, electric shock, and personal injury.

⚠ WARNING: Failure to obey this safety warning can result in death or serious injury to yourself or to others. Always follow the safety precautions to reduce the risk of fire, electric shock, and personal injury.

⚠ CAUTION: Failure to obey this safety warning may result in death or serious injury to yourself or to others. Always follow the safety precautions to reduce the risk of fire, electric, shock and personal injury.

DAMAGE PREVENTION AND INFORMATION MESSAGES

These inform user of important information and/or instructions that could lead to equipment or other property damage if not followed. Each message is preceded by the word **“NOTE”** as in the example below.

NOTE: Equipment and/or property damage may result if these instructions are not followed.



The operation of any power tool can result in foreign objects being thrown into your eyes, which can result in severe eye damage. Before beginning power tool operation, always wear safety goggles or safety glasses with side shields and a full-face shield when needed. We recommend a Wide Vision Safety Mask for use over eyeglasses or standard safety glasses with side shields, available at Sears Stores or other Craftsman outlets. Always use eye protection that is marked to comply with ANSI Z87.1

SAFETY INSTRUCTIONS

⚠ WARNING: Be sure to read and understand all instructions in this manual before using the reciprocating saw. Failure to follow all instructions may result in hazardous radiation exposure, electric shock, fire, and/or serious personal injury.

⚠ WARNING: Do not attempt to operate this tool until you have thoroughly read all instructions, safety rules, and warnings. Failure to comply with them can result in fire, electric shock, or serious personal injury. Save the manual and refer to it frequently.

GENERAL SAETY PRECAUTIONS

WORK AREA SAFETY

- **Keep work area clean and well lit.** Cluttered or dark areas invite accidents.
- **Do not operate power tools in explosive atmospheres, such as in the presence of flammable liquids, gases or dust.** Power tools create sparks which may ignite the dust or fumes.
- **Keep children and bystanders away while operating a power tool.** Distractions cause you to lose control.

ELECTRICAL SAFETY

- **Double insulated tools are equipped with a polarized plug (one blade is wider than the other.) This plug will fit in a polarized outlet only one way. If the plug does not fit fully in the outlet, reverse the plug. If it still does not fit, contact a qualified electrician to install a polarized outlet. Do not change the plug in any way.** Double insulation eliminates the need for the three wire grounded power cord and grounded power supply system.
- **Avoid body contact with grounded surfaces such as pipes, radiators, ranges and refrigerators.** There is an increased risk of electric shock if your body is grounded.
- **Don't expose power tools to rain or wet conditions.** Water entering a power tool will increase the risk of electric shock.
- **Do not abuse the cord. Never use the cord to carry the tools or pull the plug from an outlet. Keep cord away from heat, oil, sharp edges or moving parts. Replace damaged cords immediately.** Damaged cords increase the risk of electric shock.
- **When operating a power tool outside, use an outdoor extension cord marked "W-A" or "W".** These cords are rated for outdoor use and reduce the risk of electric shock. The following table shows the correct size to use, depending on cord length and nameplate amperage rating of the tool.

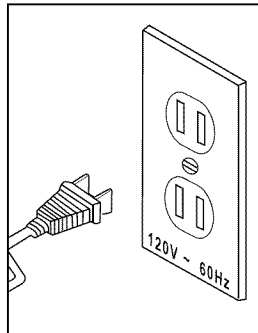

When in doubt, use the next heavier gauge. Always use UL and CSA listed extension cords.

Recommended sizes of extension cords

Ampere Rating		Total Length of Cord in feet				
		120v	25ft	50ft	100ft	150ft
More Than	Not More Than	AWG				
0	6		18	16	16	14
6	10		18	16	14	12
10	12		16	16	14	12
12	16		14	12	Not Recommended	

PERSONAL SAFETY

- **Stay alert, watch what you are doing and use common sense when operating a power tool. Do not use tool while tired or under the influence of drugs, alcohol, or medication.** A moment of inattention while operating power tools may result in serious personal injury.
- **Dress properly. Do not wear loose clothing or jewelry. Contain long hair. Keep your hair, clothing, and gloves away from moving parts.** Loose clothes, jewelry, or long hair can be caught in moving parts.
- **Avoid accidental starting. Be sure switch is off before plugging in.** Carrying tools with your finger on the switch or plugging in tools that have the switch on invites accidents.
- **Remove adjusting keys or wrenches before turning the tool on.** A wrench or a key that is left attached to a rotating part of the tool may result in personal injury.
- **Do not overreach. Keep proper footing and balance at all times.** Proper footing and balance enables better control of the tool in unexpected situations.
- **Use safety equipment. Always wear eye protection.** Dust mask, non-skid safety shoes, hard hat, or hearing protection must be used for appropriate conditions.
- **Before connecting the tool to a power source (receptacle, outlet, etc.), be sure voltage supplied is the same as that specified on the nameplate of the tool.** A power source with voltage greater than that specified for the tool can result in serious injury to the user – as well as damage to the tool.

TOOL USE AND CARE

- **Use clamps or other practical way to secure and support the workpiece to a stable platform.** Holding the work by hand or against your body is

unstable and may lead to loss of control.



- **Do not force tool. Use the correct tool for your application.** The correct tool will do the job better and more safely at the rate for which is designed.
- **Do not use tool if the switch does not turn it on or off.** Any tool that cannot be controlled with the switch is dangerous and must be repaired.
- **Disconnect the plug from the power source before making any adjustments, changing accessories, or storing the tool.** Such preventive safety measures reduce the risk of starting the tool accidentally.
- **Store idle tools out of reach of children and other untrained persons.** Tools are dangerous in the hands of untrained users.
- **Maintain tools with care. Keep cutting tools sharp and clean.** Properly maintained tools, with sharp cutting edges are less likely to bind and are easier to control.
- **Check for misalignment or binding of moving parts, breakage of parts, and any other condition that may affect the tools operation. If damaged, have the tool serviced before using.** Many accidents are caused by poorly maintained tools.
- **Use only accessories that are recommended by the manufacturer for your model.** Accessories that may be suitable for one tool, may become hazardous when used on another tool.
- **Do not alter or misuse tool.** These tools are precision built. Any alteration or modification not specified is misuse and may result in a dangerous condition.

SERVICE

- **Tool service must be performed only by qualified repair personnel.** Service or maintenance performed by unqualified personnel could result in a risk of injury.
- **When servicing a tool, use only identical replacement parts. Follow instructions in the Maintenance section of this manual.** Use of unauthorized parts or failure to follow Maintenance instructions may create a risk of shock or injury.

SAFETY SYMBOLS FOR YOUR TOOL

The label on your tool may include the following symbols.

V.....	Volts
A.....	Amps
Hz.....	Hertz
W.....	Watts
min.....	Minutes
	Alternating Current
—	Direct Current
no	No-load Speed
	Class II construction
.../min.....	Revolutions or Strokes per minute
	Indicates danger, warning caution. It means attention! Your safety is involved.

SPECIFIC SAFETY RULES SFOR JIGSAWS

- **WARNING:** To reduce the risk of injury, user must read instruction manual.
- **Keep** your body positioned to either side of the saw blade and not in direct line with the saw blade.
- **Do not reach under the workpiece.** The blade extends under the workpiece when saw is cutting.
- **Do not** touch the blade or the workpiece immediately after operation; they may be extremely hot and could burn your skin.
- **Do not** cut an oversized workpiece.
- **Check for the proper clearance** under the workpiece before cutting so that the blade will not strike the workbench or material under the workpiece.
- **Make sure** the blade is not contacting the workpiece before the switch is turned on.
- **Hold tool by insulated gripping surfaces (handles) when performing an operation where the cutting tool may contact hidden wiring or its own cord.** Contact with a “live” wire will make the exposed metal parts of the tool “live” and shock the operator.
- **Secure material before cutting.** Never hold a workpiece in your hand or across your legs. Small or thin material may flex or vibrate with the blade, causing loss of control.
- **When ripping, always use a rip fence or straight edge guide.** This improves the accuracy of the cut and reduces the chance of the blade binding.
- **Never cut more than one piece at a time. DO NOT STACK more than one workpiece on the worktable at a time.**
- **Avoid awkward operations and hand positions** where a sudden slip

- could cause your hand to move into the blade.
- **Never reach into the cutting path of the blade.**
- **Blade guide rollers** must support the blade when cutting. The rollers must rest against the back edge of blade. The only cutting operation when rollers do not support the blade is the scrolling mode. When scrolling the blade must swivel as it is guided to follow scroll patterns. Always move the base back and blade guide up and back away from blade in scrolling mode.
- **Always use blades that have the correct size and shape.** Blades that do not match the mounting hardware of the saw will run erratically and will cause loss of control.
- **Always be sure that all adjusting screws and the blade holder are fastened tightly** before making a cut. Loose adjusting screws can cause the tool to slip and loss of control may result.

⚠ WARNING: Use of this tool can generate dust containing chemicals known to cause cancer, birth defects or other reproductive harm. Some examples of these chemicals are:

- Lead from lead-based paints.
- Crystalline silica from bricks and cement and other masonry products.
- Arsenic and chromium, from chemically treated lumber.

Your risk from these exposures varies, depending upon how often you do this type of work. To reduce your exposure to these chemicals:

- Work in a well-ventilated area.
- Work with approved safety equipment, such as those dust masks that are specially designed to filter out microscopic particles.

Avoid prolonged contact with dust from power sanding, sawing, grinding, drilling and other construction activities. Wear protective clothing and wash exposed areas with soap and water.

Allowing dust to get into your mouth, eyes, or lay on the skin may promote absorption of harmful chemicals!

⚠ WARNING: Use of this tool can generate and/or disburse dust, which may cause serious and permanent respiratory or other injury. Always use Sears approved respiratory protection appropriate for the dust exposure. Direct particles away from face and body.

UNPACKING

⚠ WARNING: Your jigsaw should never be connected to the power source when you are assembling parts, making adjustments, installing or removing bits, cleaning it, or when it is not in use. Disconnecting the saw will prevent accidental starting, which could cause serious personal injury.

When unpacking the box, do not discard any packing materials until all of the contents are accounted for:

1. Carefully lift the saw out of the carton and place it on a stable, flat surface.
2. Open the box to locate the following:
 - Jigsaw
 - Edge guide
 - 2 wood-cutting blades
 - Hex key
 - Operator's manual
3. Inspect the items carefully to make sure that no breakage or damage has occurred during shipping. If any of the items listed below is damaged or missing, return the saw to your nearest Sears store or Craftsman Evolv outlet to have the saw replaced. Carefully remove the tool and any accessories from the box. Make sure that all items listed in the packing list are included.

⚠ WARNING: If any part is broken or missing, do not attempt to assemble the saw, plug in the power cord, or operate the saw until the broken or missing part has been replaced. Failure to do so could result in possible serious injury.

CARTON CONTENTS/LOOSE PARTS (Fig. 1)

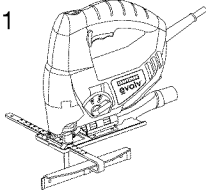
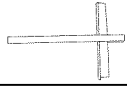
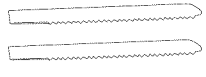
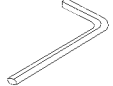
	Jigsaw	1
	Edge guide	1
	Wood-cutting blades	2
	Hex key	1

DESCRIPTION

KNOW YOUR JIGSAW (Fig. 1)

Before attempting to use this jigsaw, familiarize yourself with all its operating features and safety requirements.

⚠ WARNING: Do not allow familiarity with your saw to make you careless. Remember that a careless fraction of a second is sufficient enough to inflict severe injury.

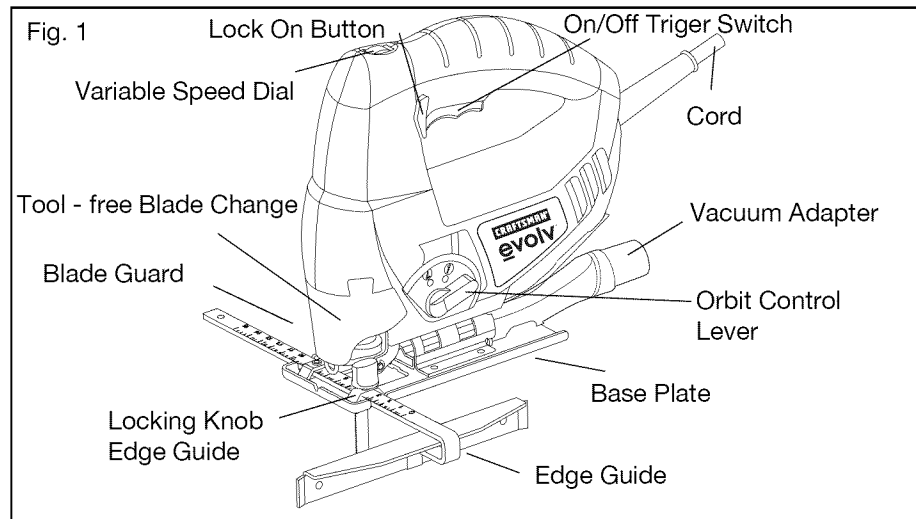

PRODUCT SPECIFICATIONS

Motor	120~60HZ, 4.5A
No-Load Speed	800-3000 (SPM)
Blade stroke	11/16"
Cutting depth: wood	2-1/4" (57mm)
Cutting depth: metal	1/4" (6 mm)
Bevel capacity	0-45°
Dust extraction	1-1/4"
Cord length	6'
Weight	3.1 lbs

⚠ WARNING: The safe use of this product requires an understanding of the information on the tool and in this operator's manual as well as knowledge of the project you are attempting. Before use of this product, familiarize yourself with all operating features and safety rules.

OPERATION

ON/OFF TRIGGER SWITCH

1. Plug your saw's power cord into a standard household power outlet.
2. Start the tool by squeezing the on/off trigger switch (Fig 2).
3. Release the trigger to stop the tool.
4. If you press the lock-on buttons that are located on the handle while the trigger switch is depressed, the switch will be locked in the operating position.
5. The lock-on button allows the operator to keep the jigsaw's motor running without continuously holding the switch. It is useful when you are operating the tool for extended periods.
6. To release the lock-on button, press and release the trigger switch.

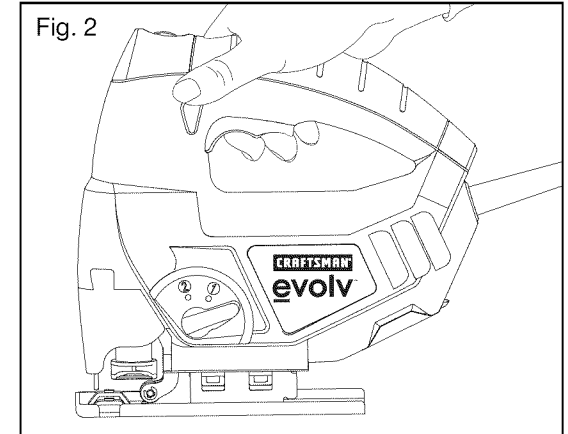

ADJUSTING THE CUTTING SPEED USING THE VARIABLE-SPEED DIAL

NOTE: Determine the optimum speed for cutting your workpiece by making a trial cut in a scrap piece of the same material. Experience will help you to determine the best results for a particular application. However, as a general rule, use slower speeds for harder, denser materials, and faster speeds for softer material.

The variable speed feature of this jigsaw enhances the cutting performance, and saves the blade from undue wear.

1. Use the variable speed dial to adjust the speed of the blade.
2. Turn the dial to increase or decrease the speed (Fig3).

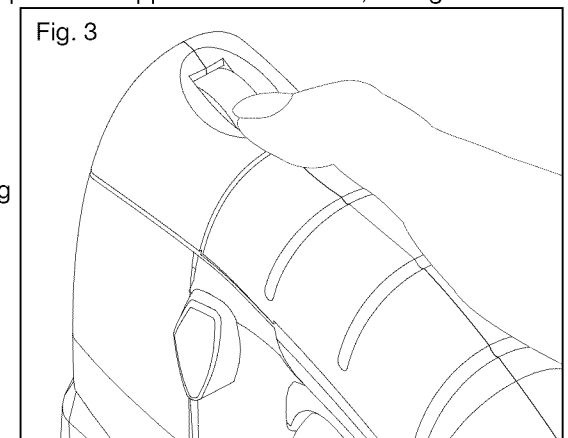

TOOL-FREE BLADE INSTALLATION

The tool-free blade change control allows for the removal and replacement of

the blade quickly and easily, without the use of additional tools.

1. Unplug the jigsaw
2. Place your finger on the lower edge of the see-through blade guard, and pull it forward until it locks in place (Fig. 4).
3. Lift the tool-free blade change holder, and insert the blade into the slot of the tool-free blade change holder. (Fig. 5)
4. Release the tool-free blade change holder to lock the blade in place.
5. Pull down on the blade to verify that the blade is securely locked in place. The teeth of the blade should be pointing forward and down.
6. Put the blade guard back down.

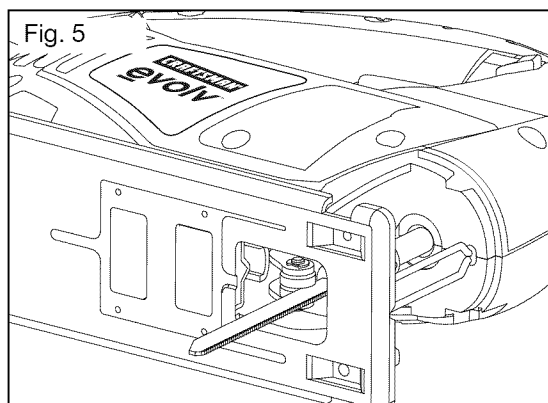
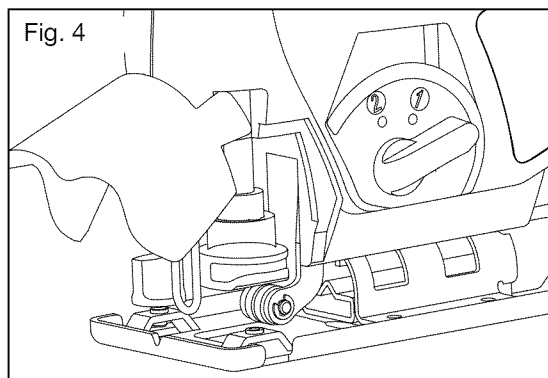

NOTE: This jigsaw can be used with both 'T' & 'U' shanked blades.

REMOVING THE BLADE

1. Unplug the jigsaw
2. Follow steps 1 through 5 of Tool-Free Blade Installation (above)
3. Carefully remove the blade.

ORBITAL ACTION

Orbital blade action thrusts the blade forward on the cutting strokes and increases the cutting speed over normal up-and-down action.

ORBIT-CONTROL LEVER (Fig. 6)

This saw is equipped with an

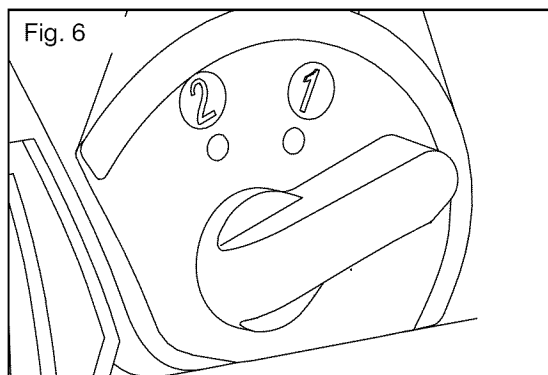

orbital control that allows you to choose the best cutting action for your material.

Simply turn the lever to the desired position for the type of cut you are making.

Turn the lever to a higher setting to increase the orbital action.

Turn the lever to a lower setting to decrease the orbital action.

There are three orbital action cutting settings that can be chosen according to different types of material.

“0” position: no orbital action for cutting most metal.

“1” position: moderate orbital action for cutting plastic, mild steel, and hardwoods.

“2” position: more aggressive orbital action for cutting plywood and soft woods.

NOTE: In order to reach full orbital action. The blade must be facing straight forward, the back of the blade must be resting in the groove of the roller, and the base plate must be positioned all the way forward. Orbital action is not detectable when the saw is running freely. The saw must be cutting in order for orbital action to occur. The cutting speed is easier to see when cutting thicker material.

SAWDUST REMOVAL (Fig. 7)

Use the detachable vacuum adapter (dust port) to remove dust and chips from the immediate workspace in order to help keep the cutting line clear.

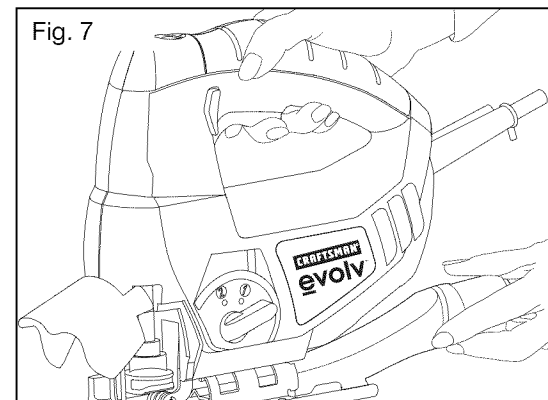

ADJUSTING THE BASE PLATE FOR BEVEL CUTTING (Fig. 8, Fig. 9)

WARNING: In order to prevent damage to the tool when bevel cutting, the cutting edge of the blade must face the front of the tool.

1. Unplug the jigsaw
2. To adjust the cutting angle, turn the tool upside down, remove the vacuum adapter, and locate the hex screw on the underside of the tool that secures the blade-guide assembly.

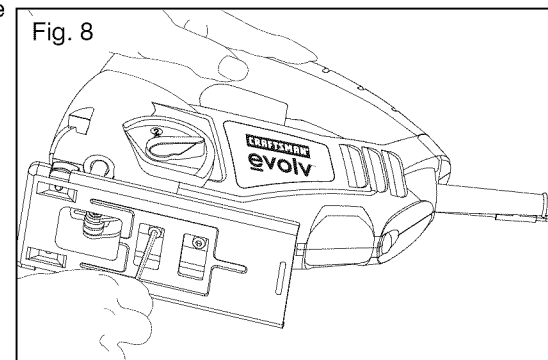

3. Loosen the hex screw that secures the base plate. Move the base plate slightly forward, and tilt it to the required angle (between 0° and 45°) using the scale (0°, 15°, 30° and 45°) that is marked on the base bracket. The base plate has indents at 0° and ±45° for easy angle setting.
4. Slide the blade-guide assembly until the blade guide rests against the back edge of the blade.
5. Retighten the hex screws.
6. In order to ensure accurate work, it is necessary to make a trial cut, measure the work, and reset the angle until the correct setting is achieved.

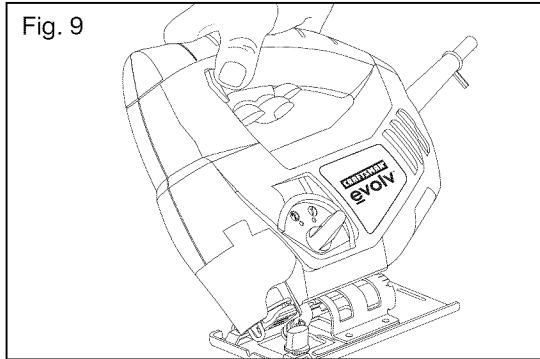

THE EDGE GUIDE (Fig.10)

This accessory (included) is used for straight cutting:

Insert the bar of the edge guide through the slots in the base of the jigsaw (Fig10). The bar of the edge guide can be inserted from either side of the base.

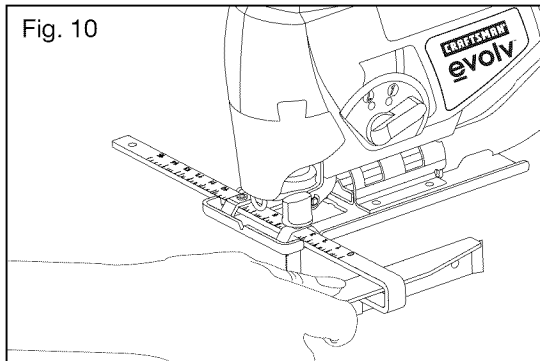

GENERAL CUTTING TIPS

⚠ WARNING: Do not let familiarity with your saw make you careless. Remember that a careless fraction of a second is sufficient to cause severe injury.

⚠ WARNING: Always wear safety goggles or safety glasses when operating this tool.

⚠ WARNING: The use of attachments or accessories that are not recommended is dangerous.

1. Place the best side of the material face-down and secure it in a bench vise or clamp it in place.
2. Draw your cutting lines or designs on the side facing you.
3. Place the front edge of the base plate on the material to be cut and align the blade with your cutting line. (Fig 11)
4. Hold the saw firmly and turn it on.

5. Press down (to keep saw base plate against the workpiece) as you slowly push the saw in the direction of the cut.
6. Gradually build up the blade speed, cutting as close to the line as possible (unless you want to leave enough room for finish sanding).
7. As you cut, you may need to reposition the vise or clamps to keep the workpiece stable.
8. Do not force the saw, because the blade teeth may rub and wear without cutting, which may result in breaking the blade.
9. Always let the saw do most of the work.
10. Always cut slowly when following curves, so the blade can cut through cross grain. This will provide an accurate cut and will prevent the blade from wandering.

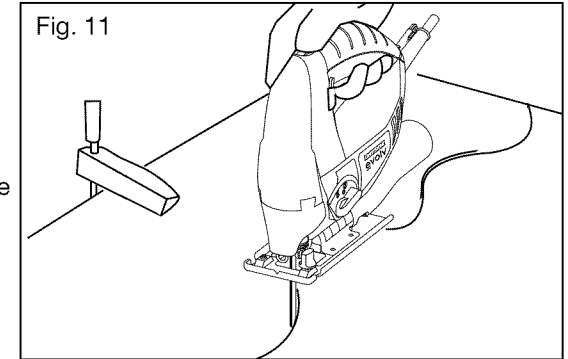

METAL CUTTING

1. When cutting metal, always clamp the metal workpiece to a stable platform. Thin metal should be sandwiched between two pieces of wood or tightly clamped to a single piece of wood (wood on top of the metal). Draw the cut lines or design on the top piece of wood.
2. When cutting metals, suitable cooling/cutting oil must be used. For easier cutting, lubricate the blade with a stick of cutting wax (if available) or use cutting oil when cutting steel. Spread the oil onto the blade or workpiece at regular intervals during cutting in order to reduce wear or overheating the blade.
3. When cutting aluminum extrusion or angle iron, clamp the work in a bench vise and saw close to the vise jaws.
4. Be extremely careful to move the saw very slowly as you cut. Use slower speeds. Do not twist, bend or force the blade.
5. If the saw jumps or bounces as you cut, change to a blade with finer teeth. If the blade begins to clog when cutting soft metal, change to a blade with coarser teeth.
6. When sawing tubing with a diameter larger than the blade is deep, cut through the wall of the tubing and then insert the blade into the cut, rotating the tube as you saw.

⚠ WARNING: To avoid accidents always disconnect the tool from the power source before making any adjustments or attaching accessories.

CUTTING WITH A STRAIGHTEDGE (Fig. 12)

⚠ WARNING: To avoid accidents, always disconnect the tool from the power source before making any adjustments or attaching accessories.

1. Always use a rough-cut blade whenever possible.
2. Mark the cutting line. Note the distance between the saw blade and the side of the saw's base plate. Position the straightedge parallel to the cut line and at a distance from the cut line that is equal to the distance between the edge of the base plate and the saw blade.

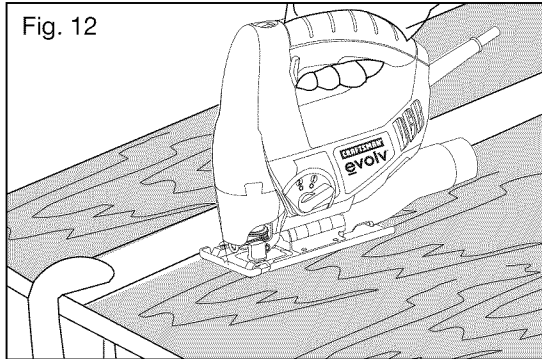

OR

Mark the side edge of the saw base and clamp the straightedge on the mark and parallel to the cut.

3. As you cut, keep the saw base edge flush against the straightedge and flat on top of the workpiece.

PLUNGE CUTTING (Fig. 13)

Plunge cutting is useful and time-saving for making rough openings in soft materials. It makes it unnecessary to drill a hole for an inside or pocket cut.

1. Draw lines for the opening.
2. Hold saw firmly and tilt it forward so the front edge of the base plate rests on the workpiece.
3. Make sure that the blade is well clear of the workpiece.
4. Start the saw and then gradually lower the blade.
5. When the blade touches the workpiece, continue pressing down on the front edge of the base plate.
6. Slowly pivot the saw on the front edge of the base plate until the blade cuts through and the base plate rests flat on the workpiece.
7. Then begin sawing on the cut line.

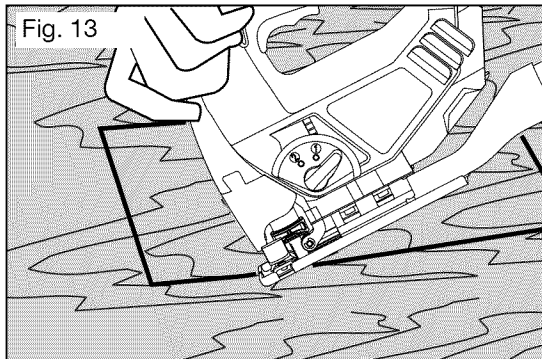

IMPORTANT: Do not try to plunge cut into hard materials, such as steel.

MAINTENANCE

⚠ WARNING: To ensure safety and reliability, all repairs should be performed by a qualified service technician at a Sears Service Center.

⚠ WARNING: For your safety, always turn off the switch and disconnect the tool from the power source before performing any maintenance or cleaning.

Periodic maintenance of your jigsaw allows for long life and trouble-free operation. A cleaning and maintenance schedule should be maintained.

As a common-sense and preventive maintenance practice, follow these recommended steps:

- Inspect the blade; check it for wear or damage.
- Use a soft clean and damp cloth to wipe the tool housing. A mild detergent can be used but nothing like alcohol, gasoline or other cleaning agent. Never use caustic agents to clean plastic parts.
- Keep the ventilation slots of the motor clean to prevent overheating of the motor. Electric tools are subject to accelerated wear and possible premature failure when they are used to work on fiberglass boats and sports cars, wallboard, spackling compounds or plaster. The chips and grindings from these materials are highly abrasive to electrical tool parts, such as bearings, brushes, commutators, etc. Consequently, it is not recommended that this tool be used for extended work on any fiberglass material, wallboard, spackling compound, or plaster. During any use on these materials, it is extremely important that the tool is cleaned frequently by blowing with an air jet.

⚠ WARNING: Always wear safety goggles or safety glasses with side shields during power tool operations or when blowing dust. If operation is dusty, also wear a dust mask.

⚠ WARNING: Keep the tool's air vents unclogged and clean at all times.

⚠ WARNING: Avoid using solvents when cleaning plastic parts. Most plastics are susceptible to damage from various types of commercial solvents and may be damaged by their use. Use clean cloths to remove dirt, dust, oil, grease, etc.

⚠ WARNING: Do not at any time let brake fluids, gasoline, petroleum-based products, penetrating oils, etc. to come in contact with plastic parts. Chemicals can damage, weaken or destroy plastic which may result in serious personal injury.

⚠ WARNING: Water must never come into the tool.

LUBRICATION

All of the bearings in this tool are lubricated with a sufficient amount of high-grade lubricant for the life of the tool under normal operating conditions. Therefore, no further lubrication is required.

TROUBLE SHOOTING

PROBLEM	CAUSE	SOLUTION
Will not start when trigger is squeezed	Check to be sure power cord is connected to power source and that power source (outlet) is operable	Connect to power source. Confirm power source (outlet) is operable
Will not cut	Check blade	Replace if teeth are dull or worn
Motor overheating	Be sure cooling vents are free from saw dust and obstacles	Clean, clear vents. Do not cover with hand during operation

PARTS LIST

Jigsaw MODEL NUMBER 320.17434

Always mention the Model Number when ordering parts for this tool

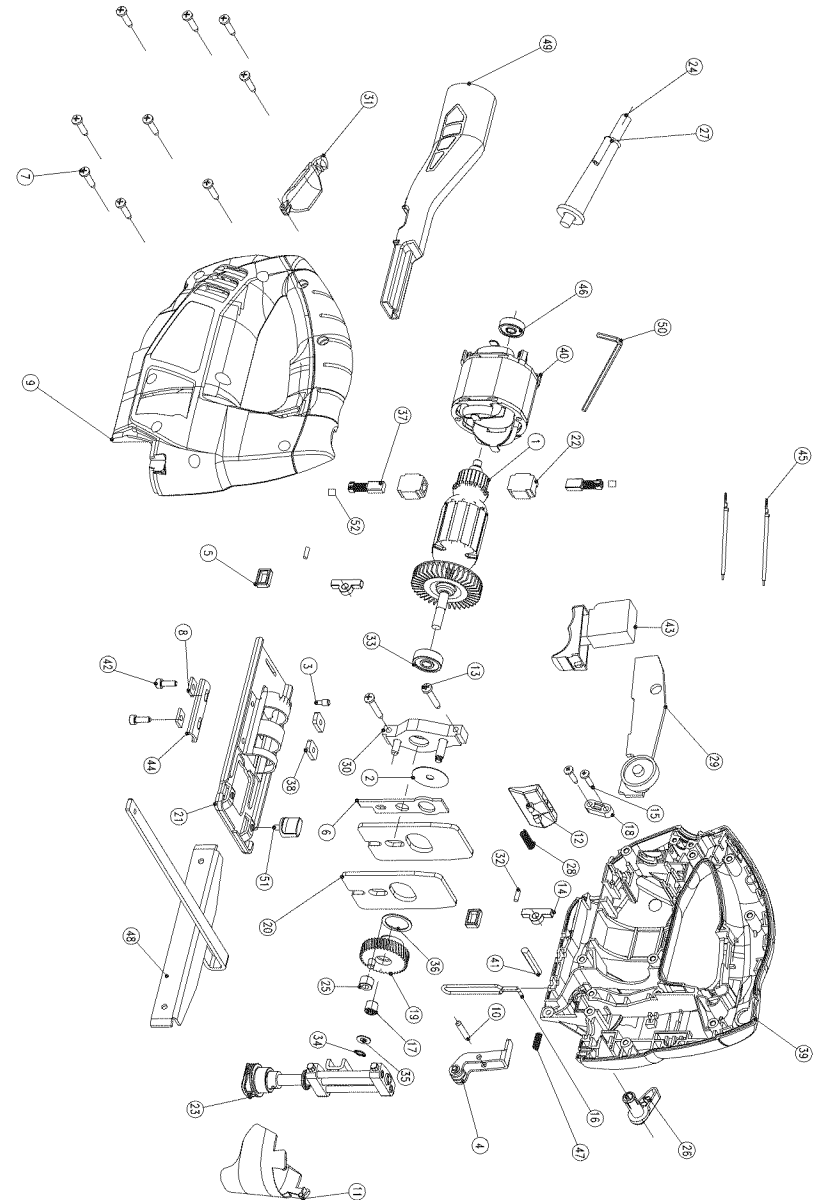

PARTS LIST

No	Part No	Part Name	QTY
1	2750122000	Rotor	1
2	3700214000	Washer	1
3	3550146000	Located Pin	1
4	2821972000	Roller Support Set	1
5	3520061000	Sliding Block	2
6	3700229000	Pendulum Plate	1
7	5610042000	Tapping Screw	9
8	3700149000	Square Washer	2
9	3320295000	Right Housing Assy	1
10	3550177000	Guiding Roller Support Pin	1
11	3121725000	Transparent Guard	1
12	3120473000	Lock Button	1
13	5610044000	Tapping Screw	2
14	3520060000	Bushing	2
15	5610024000	Tapping Screw	2
16	3650007000	Wire Guard	1
17	5700184000	Needle Bearing	1
18	3120234000	Cord Anchorage	1
19	2820473000	Gear Set	1
20	3700213000	Counterweight	2
21	2821924000	Base Plate Assy	1
22	2800022000	Brush Holder	2
23	2822029000	Guiding Rod Set	1
24	4810002000	Power Cord & Plug	1
25	3520126000	Crank Roller	1
26	3121726000	Pendulum Lever	1
27	3121037000	Cord Guard	1
28	3660075000	Spring	1
29	4900251000	Speed Adjustor ASSY	1

No	Part No	Part Name	QTY
30	2820114000	Bearing Support ASSY	1
31	3120472000	Blade Cover	1
32	3550206000	Needle Pin	2
33	5700005000	Ball Bearing	1
34	5660004000	Circlips For Shaft	1
35	3700197000	Washer	1
36	3700147000	Washer C	1
37	4960015000	Carbon Brush	2
38	3700148000	Nut	2
39	3320294000	Left Housing Assy	1
40	2740101000	Stator	1
41	3700231000	Pendulum Lever Shaft	1
42	5620011000	Hexagon Socket Screw	2
43	4870019000	Switch	1
44	3703598000	Clamp	1
45	4860005000	Internal Wire ASSY	2
46	5700004000	Ball Bearing	1
47	3660060000	Spring	1
48	3700675000	Rip Fence	1
49	3320385000	Vacuum Adapter	1
50	5680019000	Hexagon Wrench	1
51	3400175000	Knob	1
52	3700491000	Flash Board	2

NOTE

NOTE

Get it fixed, at your home or ours!

Your Home

For expert troubleshooting and home solutions advice:

manage my home

www.managemyhome.com

For repair – **in your home** – of **all** major brand appliances, lawn and garden equipment, or heating and cooling systems, **no matter who made it, no matter who sold it!**

For the replacement parts, accessories and owner's manuals that you need to do-it-yourself.

For Sears professional installation of home appliances and items like garage door openers and water heaters.

1-800-4-MY-HOME®

(1-800-469-4663)

www.sears.com

Call anytime, day or night

(U.S.A. and Canada)

www.sears.ca

Our Home

For repair of carry-in items like vacuums, lawn equipment, and electronics, call anytime for the location of the nearest **Sears Parts & Repair Service Center**

1-800-488-1222 (U.S.A.)

www.sears.com

1-800-469-4663 (Canada)

www.sears.ca

To purchase a protection agreement on a product serviced by Sears:

1-800-827-6655 (U.S.A.)

1-800-361-6665 (Canada)

Para pedir servicio de reparación a domicilio, y para ordenar piezas:

1-888-SU-HOGAR®

(1-888-784-6427)

Au Canada pour service en français:

1-800-LE-FOYER^{MC}

(1-800-533-6937)

www.sears.ca

Sears

© Sears Brands, LLC

® Registered Trademark / TM Trademark / SM Service Mark of Sears Brands, LLC

® Marca Registrada / TM Marca de Fábrica / SM Marca de Servicio de Sears Brands, LLC

^{MC} Marque de commerce / ^{MD} Marque déposée de Sears Brands, LLC