

PRO-FORM®

520

0-10 MPH · 2.0 HP · POWER INCLINE

Model No. PFTL10041

Serial No. _____

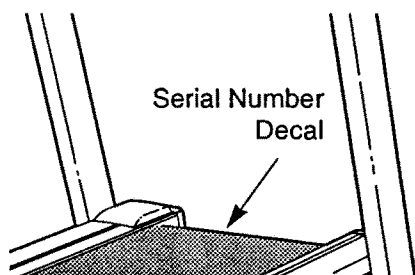

QUESTIONS?

As a manufacturer, we are committed to providing you complete customer satisfaction. If you have questions, or find there are missing or damaged parts, we will guarantee you complete satisfaction through direct assistance from our factory. TO AVOID UNNECESSARY DELAYS, PLEASE CALL DIRECT TO OUR TOLL-FREE CUSTOMER HOT LINE. The trained technicians on our Customer Hot Line will provide immediate assistance, free of charge to you.

CUSTOMER HOT LINE:

1-800-999-3756

Mon.-Fri., 6 a.m.-6 p.m. MST

▲ CAUTION:

Read all safety precautions and instructions in this manual carefully before using this equipment. Save this manual for future reference.

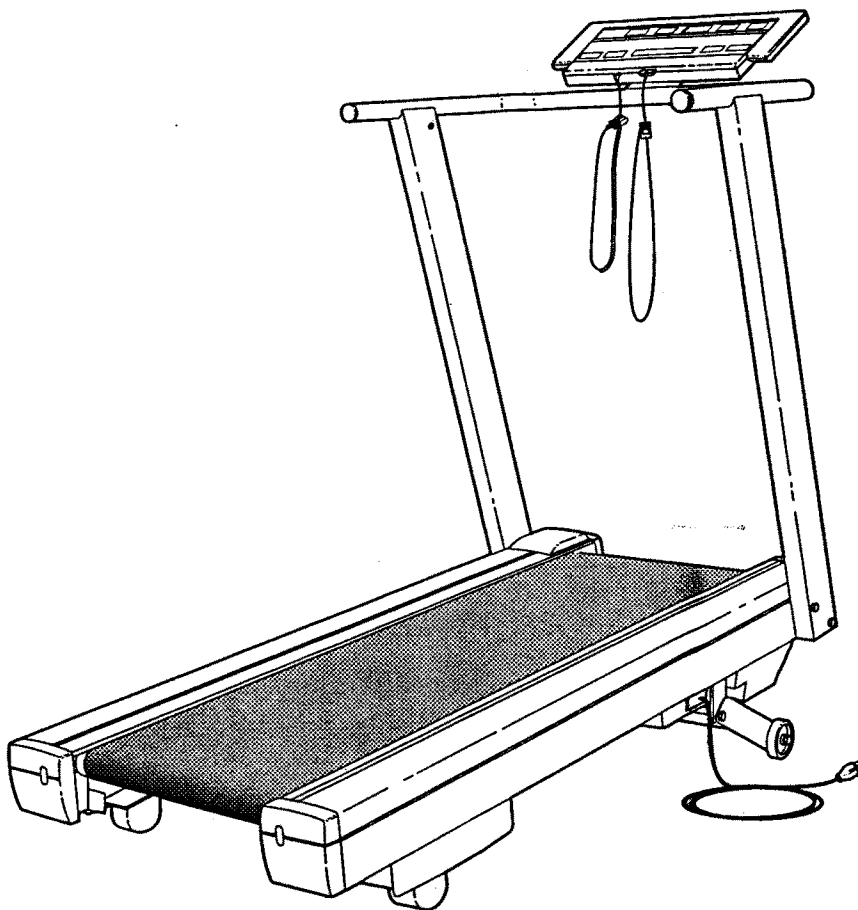

OWNER'S MANUAL

LIMITED WARRANTY

Proform Fitness Products, ("PROFORM"), warrants this product to be free from defects in workmanship and material, under normal use and service conditions, for a period of ninety (90) days from the date of purchase. This warranty extends only to the original purchaser. PROFORM's obligation under this warranty is limited to replacing or repairing, at PROFORM's option, the product at one of its authorized service centers. All products for which warranty claim is made must be received by PROFORM at one of its authorized service centers with all freight and other transportation charges prepaid, accompanied by sufficient proof of purchase. All returns must be pre-authorized by PROFORM. This warranty does not extend to any product or damage to a product caused by or attributable to freight damage, abuse, misuse, improper or abnormal usage or repairs not provided by a PROFORM authorized service center or for products used for commercial or rental purposes. No other warranty beyond that specifically set forth above is authorized by PROFORM.

PROFORM IS NOT RESPONSIBLE OR LIABLE FOR INDIRECT, SPECIAL OR CONSEQUENTIAL DAMAGES ARISING OUT OF OR IN CONNECTION WITH THE USE OR PERFORMANCE OF THE PRODUCT OR OTHER DAMAGES WITH RESPECT TO ANY ECONOMIC LOSS, LOSS OF PROPERTY, LOSS OF REVENUES OR PROFITS, LOSS OF ENJOYMENT OR USE, COSTS OF REMOVAL, INSTALLATION OR OTHER CONSEQUENTIAL DAMAGES OF WHATSOEVER NATURE. SOME STATES DO NOT ALLOW THE EXCLUSION OR LIMITATION OF INCIDENTAL OR CONSEQUENTIAL DAMAGES. ACCORDINGLY, THE ABOVE LIMITATION MAY NOT APPLY TO YOU.

THE WARRANTY EXTENDED HEREUNDER IS IN LIEU OF ANY AND ALL OTHER WARRANTIES AND ANY IMPLIED WARRANTIES OF MERCHANTABILITY OR FITNESS FOR A PARTICULAR PURPOSE IS LIMITED IN ITS SCOPE AND DURATION TO THE TERMS SET FORTH HEREIN. SOME STATES DO NOT ALLOW LIMITATIONS ON HOW LONG AN IMPLIED WARRANTY LASTS. ACCORDINGLY, THE ABOVE LIMITATION MAY NOT APPLY TO YOU.

This warranty gives you specific legal rights. You may also have other rights which vary from state to state.

PROFORM FITNESS PRODUCTS, 1500 S. 1000 W., LOGAN UT 84321-9813

PRO-FORM®

520

0-10 MPH · 2.0 HP · POWER INCLINE

TABLE OF CONTENTS

IMPORTANT SAFETY PRECAUTIONS	4
BEFORE YOU BEGIN	5
ASSEMBLY	6
OPERATION AND ADJUSTMENT	6
TROUBLE-SHOOTING	10
CONDITIONING GUIDELINES	12
PART LIST	14
EXPLODED DRAWING	15
ORDERING REPLACEMENT PARTS	Back Cover

⚠ WARNING: Before beginning this or any exercise program, consult your physician. This is especially important for persons over the age of 35 or persons with pre-existing health problems. Read all instructions before using. PROFORM assumes no responsibility for personal injury or property damage sustained by or through the use of this product.

IMPORTANT SAFETY PRECAUTIONS

⚠ WARNING: To reduce the risk of burns, fire, electric shock or injury to persons, read the following important safety precautions and information before operating the treadmill.

1. Position the treadmill on a level surface, with at least 8 feet of clearance behind the treadmill. Do not place the treadmill near water, outdoors or on any surface that blocks an air opening. Do not operate where aerosol products are used or where oxygen is being administered.
2. When connecting the power cord (see **PLUGGING IN THE POWER CORD** on page 6 and 7), plug the power cord directly into a grounded circuit capable of carrying 12 or more amps. No other appliance should be on the same circuit. Keep the power cord away from heated surfaces. If an extension cord is needed, use only a 14-gauge general-purpose cord of five feet or less in length with a three-wire conductor.
3. Never move the walking belt while the power is turned off. Do not operate the treadmill if the power cord or plug is damaged, or if the treadmill is not working properly. (See **BEFORE YOU BEGIN** on page 5 if the treadmill is not working properly.)
4. Wear appropriate exercise clothing when using the treadmill; do not wear loose clothing that could become caught in the treadmill. *Always wear athletic shoes; never use the treadmill with bare feet, wearing only stockings or in sandals.* Athletic support clothes are recommended for both men and women.
5. The pulse earclip is not a medical device. Various factors, including the user's movement while exercising, may affect the accuracy of heart rate readings. The earclip is intended only as an exercise aid in determining heart rate trends in general.
6. Never start the treadmill while you are standing on the walking belt. Always hold the handrail when exercising on the treadmill.
7. Never allow more than one person on the treadmill at a time. The treadmill should not be used by persons weighing more than 250 pounds.
8. Keep small children away from the treadmill at all times. Never leave the treadmill unattended while it is running. Always turn the power off when the treadmill is not in use.
9. Never drop or insert any object into any opening.
10. To reduce the possibility of overheating, do not operate the treadmill continuously for longer than 1 hour.
11. The treadmill is capable of high speeds. Adjust the speed slowly to avoid sudden jumps in speed.
12. Use the treadmill only as described in this manual.
13. Always unplug the power cord before performing the maintenance and adjustment procedures described in this manual. Never remove the safety cover unless instructed to do so by an authorized service representative. Servicing other than the procedures in this manual should be performed by an authorized service representative only.

SAVE THESE INSTRUCTIONS

BEFORE YOU BEGIN

Thank you for selecting the PROFORM® 520 treadmill. The PROFORM 520 treadmill blends advanced technology with innovative design to let you enjoy an excellent form of cardiovascular exercise in the convenience and privacy of your home.

For your safety and benefit, read this manual carefully before using the treadmill. If you have additional questions, please call our Customer Service Department toll-free at 1-800-999-3756, Monday through Friday, 6 a.m. until 6 p.m. Mountain Time (excluding holidays). To help us assist you, please note the product model number and serial number before calling. The model number of the treadmill is PFTL10041. The serial number can be found on a decal attached to the treadmill (see the front cover of this manual for the location).

Before reading further, please review the drawing below and familiarize yourself with the parts that are labeled.

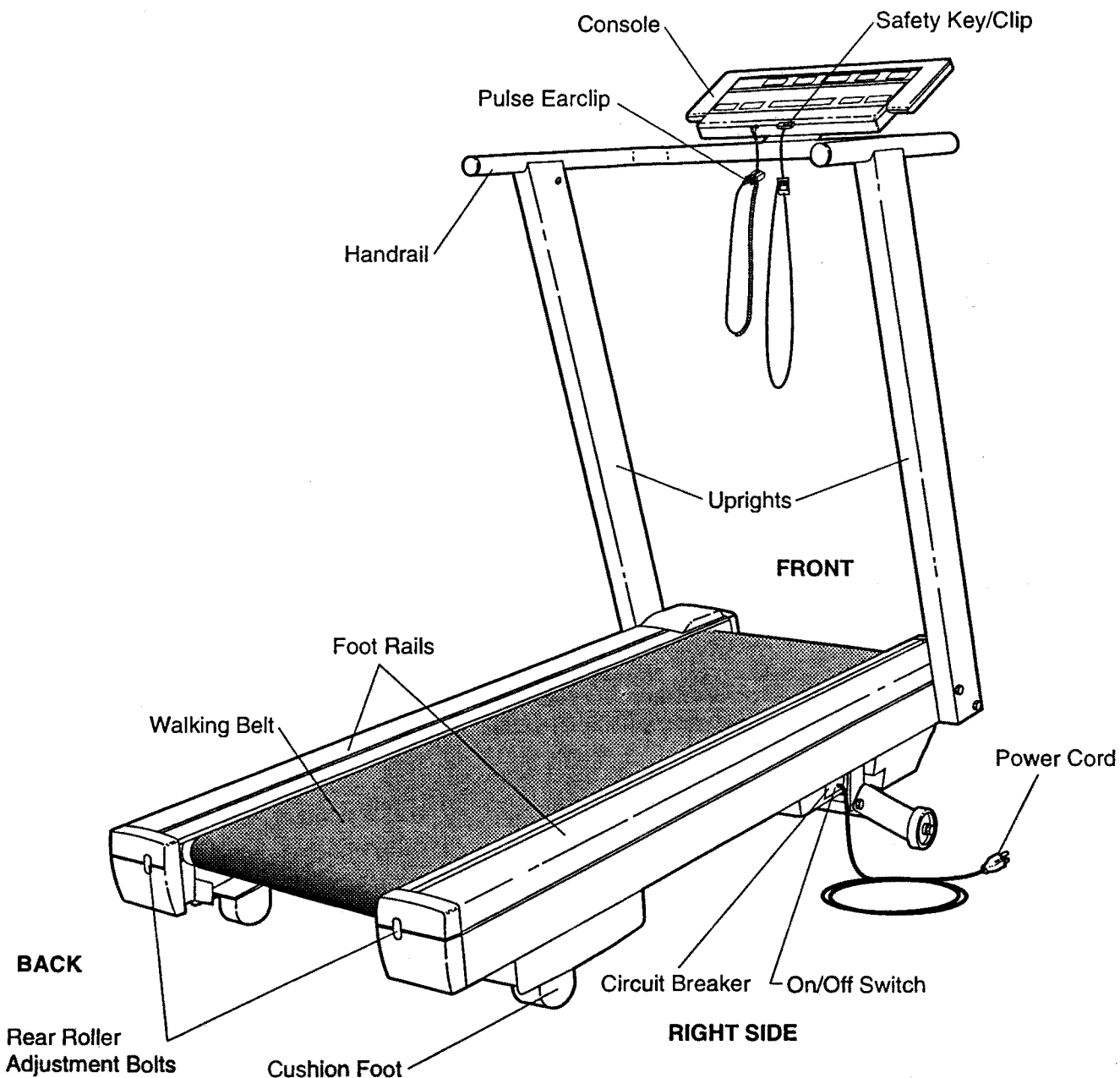

ASSEMBLY

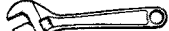
The help of a second person is needed. Set the treadmill in a cleared area and remove all packing materials. Do not dispose of the packing materials until assembly is completed. **TOOLS REQUIRED FOR ASSEMBLY:** The 7/32" allen wrench  included and your own adjustable wrench .

1. With the help of a second person, raise the Right Upright (16) and Left Upright (not shown) to a vertical position.

Align the hole in the lower end of the Right Upright with the hole in the side of the Frame (45). Insert a 3/8" x 3 1/4" Bolt (20), with a Flat Washer (19), into the Right Upright and tighten the Bolt into the Frame. Tighten the Bolt that is already in the Right Upright.

Attach a Bolt and Washer on the left side in the same manner (not shown).

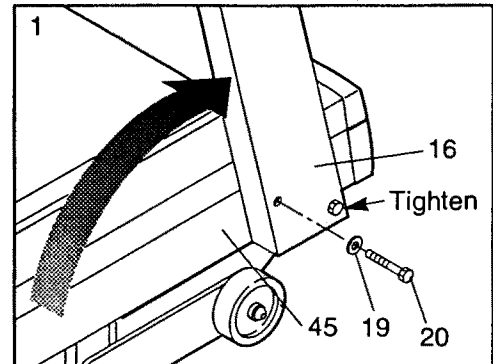

2. With the help of a second person, rotate the Handrail (7) up as shown. Insert two Handrail Lock Bolts (1) into the Left and Right Uprights (2, 16) and tighten the Bolts with the 7/32" Allen Wrench (91).

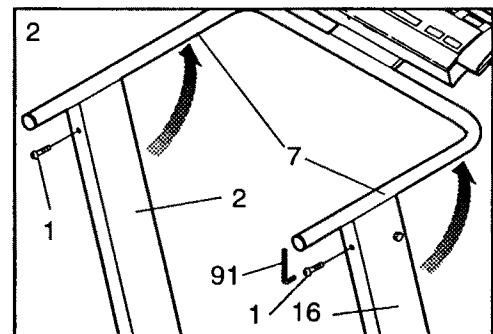

3. Slide the metal Clothes Clip onto the Pulse Earclip in the indicated location. The use of the Pulse Earclip is explained in the LED DISPLAY OPERATION section on page 9.

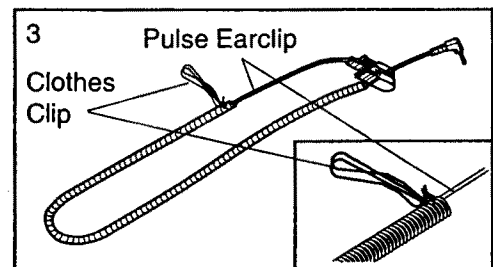

4. Remove the paper backing from the Wrench Clip (68). Press the Wrench Clip onto the Frame (45) in the indicated location. Press the 3/16" Allen Wrench (67) into the Wrench Clip.

Make sure that all parts are tightened before using the treadmill.

Note: To protect the floor, a covering should be placed under the treadmill.

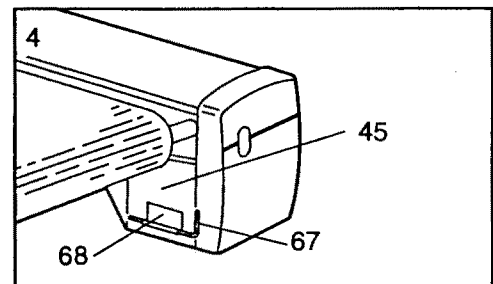

OPERATION AND ADJUSTMENT

PLUGGING IN THE POWER CORD

This product must be grounded. If it should malfunction or break down, grounding provides a path of least resistance for electric current to reduce the risk of electric shock. This product is equipped with a cord having an equipment-grounding conductor and a grounding plug. **Plug the power cord into an appropriate outlet that is properly installed and grounded in accordance with all local codes and ordinances.**

⚠ DANGER: Improper connection of the equipment-grounding conductor can result in a risk of electric shock. Check with a qualified electrician or serviceman if you are in doubt as to whether the product is properly grounded. Do not modify the plug provided with the product—if it will not fit the outlet, have a proper outlet installed by a qualified electrician.

This product is for use on a nominal 120-volt circuit, and has a grounding plug that looks like the plug illustrated in Drawing 1.

A temporary adapter that looks like the adapter illustrated in Drawing 2 may be used to connect this plug to a 2-pole receptacle as shown in Drawing 2 if a properly grounded outlet is not available. The temporary adapter should be used only until a properly grounded outlet (Drawing 1) can be installed by a qualified electrician. The green colored rigid ear, lug, or the like extending from the adapter **must be** connected to a permanent ground such as a properly grounded outlet box cover. Whenever the adapter is used it **must be** held in place by a metal screw.

Some 2-pole receptacle outlet box covers are not grounded. Contact a qualified electrician to determine if the outlet box cover is grounded before using an adapter.

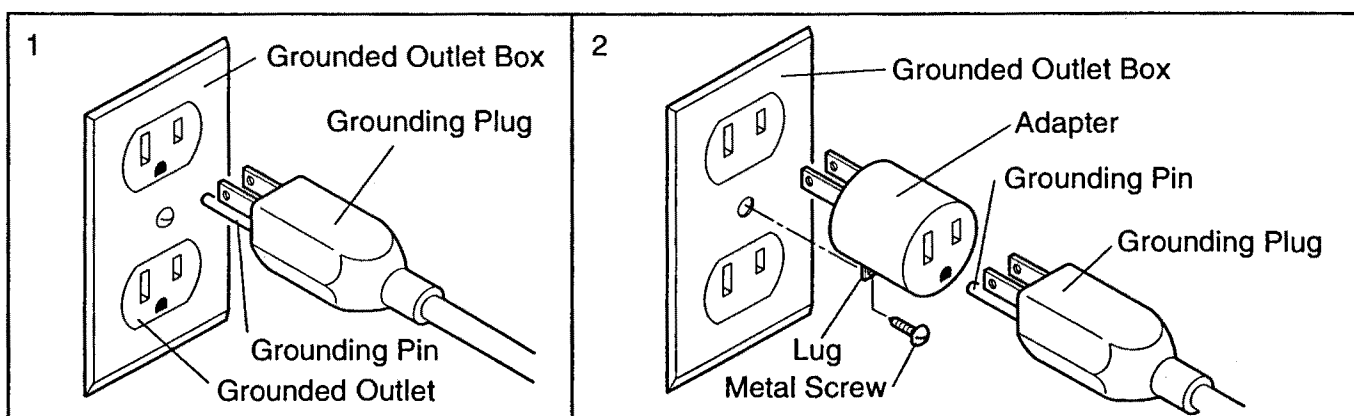

BREAKING IN THE MAINTENANCE-FREE WALKING PLATFORM

IMPORTANT: This treadmill features a maintenance-free walking platform. **After completion of the following break-in procedure**, the walking platform requires no further maintenance. The walking platform must be broken in completely so that the coating on the walking platform impregnates the walking belt. If this is not done, the treadmill may function erratically. Follow the steps below to break in the walking platform completely.

1. Adjust the incline of the treadmill to the highest setting. (See INCLINE CONTROL on page 9.)
2. Adjust the speed of the walking belt to about 3 or 4 miles per hour. (See SPEED CONTROL on page 8.) Hold the handrail and begin walking on the treadmill. **Be sure to walk on all areas of the walking belt**—not only on the center. Continue for 5 to 10 minutes, or until the walking belt no longer slows as you walk.
3. To complete the break-in procedure, first **stop the walking belt and unplug the power cord**. Lift each side of the walking belt and apply the included lubricant generously to the area of the walking platform shown at the right. This one-time application completes the break-in of the maintenance-free walking platform.
IMPORTANT: The included 100% silicone lubricant is specially formulated for this one-time application. Do not apply any other silicone lubricant or spray. Such substances may damage the walking platform and cause excessive wear or premature failure of the treadmill.

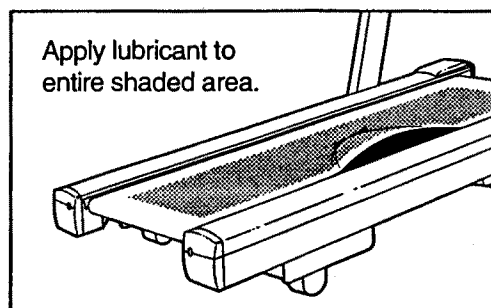

Note: The treadmill may function erratically during the break-in procedure. The walking belt may slow to a stop or surge in speed, and an error code ("E1," "E2," "E3," etc.) may appear in the SPEED display. If this happens, remove the safety key, wait for ten seconds and then reinsert it.

DIAGRAM OF THE CONSOLE

The heart of the treadmill is the sophisticated console. The console features a safety key-operated power switch, electronic speed and incline controls and six independent LED displays to give you continuous exercise feedback. Please read these instructions carefully before operating the console. Note: If there is a sheet of protective plastic on the face of the console, peel it off before operating the console.

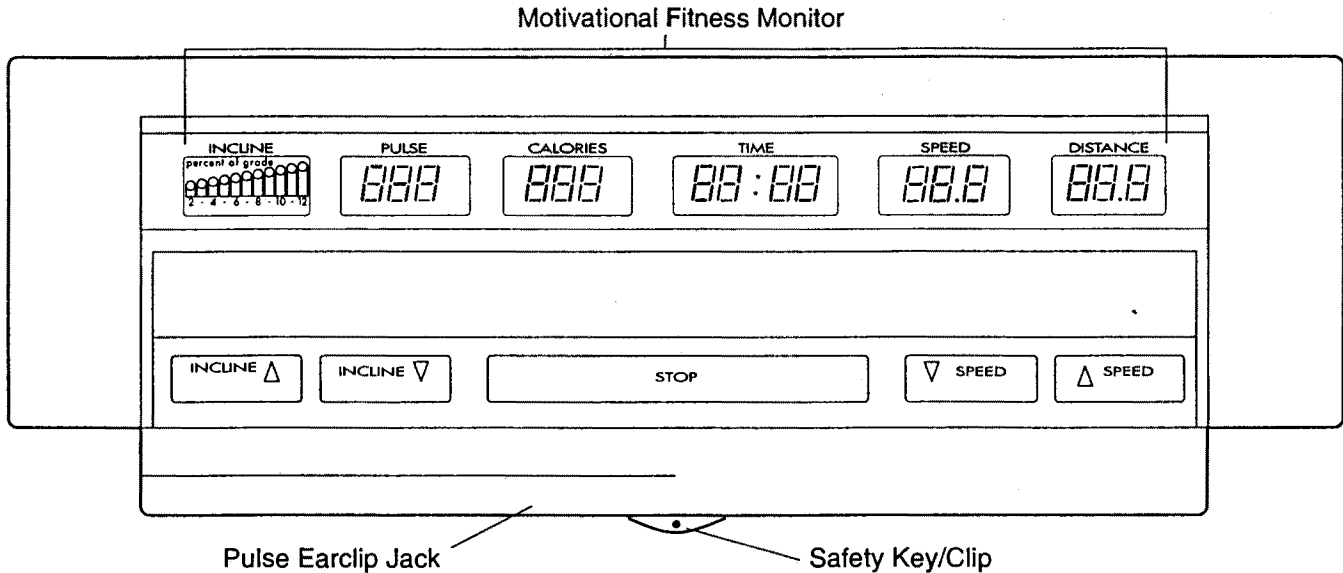

TURNING ON THE POWER

If the safety key is in the console, remove it. Make sure that the on/off switch located near the power cord is in the ON position (see the drawing at the right). Plug in the power cord (see PLUGGING IN THE POWER CORD on pages 6 and 7). All displays and indicators on the console will flash three times.

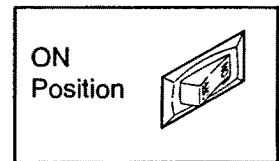

Step onto the foot rails of the treadmill. Locate the clip attached by a cord to the safety key, and slide the clip onto the waistband of your clothing.

▲ WARNING: Do not stand on the walking belt when turning the power on. Always wear the clip when operating the treadmill.

Insert the safety key into the console. The six LED displays will light. Note: If the safety key was in the console when the power cord was plugged in, a "PO" will appear in the speed display. If this occurs, remove the safety key, wait for ten seconds and then reinsert it.

SPEED CONTROL

When the power is turned on, the walking belt will be stationary. The speed of the walking belt can be controlled by pressing the SPEED buttons. Each time the SPEED increase button is pressed, the speed will increase by 0.1 mile per hour, beginning at 0.5 miles per hour. Each time the SPEED decrease button is pressed, the speed will decrease by 0.1 mile per hour. The buttons can be held down to change the speed rapidly. The speed can be set at a minimum of 0.5 miles per hour, up to a maximum of 10 miles per hour, in increments of 0.1 mile per hour.

▲ WARNING: After the SPEED buttons are pressed, it will take a few seconds for the walking belt to reach the selected speed. Adjust the speed gradually until you are familiar with the operation of the treadmill.

Press the SPEED increase button until the walking belt begins to move at slow speed. Hold the handrail, step carefully onto the walking belt and begin exercising. Change the speed as desired by pressing the SPEED buttons. To stop the walking belt, hold down the SPEED decrease button. The walking belt can be stopped quickly, if desired, by pressing the STOP bar.

INCLINE CONTROL

To vary the intensity of your exercise, the incline of the treadmill can be changed by pressing the INCLINE buttons. Each time one of the buttons is pressed, the incline will change by 1%. The buttons can be held down to change the incline rapidly. The incline can be set at a minimum of 2%, up to a maximum of 12%. Note: After the buttons are pressed, it will take a few seconds for the treadmill to reach the selected incline.

LED DISPLAY OPERATION

INCLINE DISPLAY—The incline display will show the selected incline of the treadmill.

PULSE DISPLAY—To use the pulse display of the console, plug the pulse earclip into the jack on the console. Attach the earclip to your left ear lobe and slide the metal clothes clip onto your collar. After a few seconds, your pulse will be shown in the pulse display. If your pulse is not shown, rub your ear lobe and reposition the earclip. It may be helpful to stand still while measuring your pulse.

CALORIES DISPLAY—The calories display will show the approximate number of nutritional Calories that you have burned. Note: The number of Calories burned will vary slightly depending on the speed and incline of the treadmill.

TIME DISPLAY—This display shows the elapsed time.

SPEED DISPLAY—This display shows the current speed of the walking belt.

DISTANCE DISPLAY—The distance display will show the total distance that you have walked or run, in miles.

Note: To reset the displays, remove the safety key then reinsert it into the console.

INFORMATION MODE

The console features an information mode to let you keep track of trip time and distance, as well as the total time and distance that the treadmill has been operated. To select the information mode, hold down the STOP bar while inserting the safety key into the console.

When the information mode is selected, the time display will show the trip time, up to 9,999 hours. The distance and speed displays together will show the trip distance, up to 99,999 miles. While the trip time and distance are displayed, they can be reset to zero by pressing the INCLINE decrease button.

To view the total time and distance, press the INCLINE increase button. The time display will show the total time, up to 9,999 hours. The distance and speed displays together will show the total distance, up to 99,999 miles.

To exit the information mode, remove the safety key.

TURNING OFF THE POWER

To turn off the power, remove the safety key from the console. Store the safety key in a secure location.

TROUBLE-SHOOTING

Most treadmill problems can be solved by following the simple steps below. Find the symptom that applies, and follow the steps listed. If further assistance is needed, call our Customer Service Department toll-free at 1-800-999-3756, Monday through Friday, 6 a.m. until 6 p.m. Mountain Time.

1. SYMPTOM: THE POWER DOES NOT TURN ON

- a. Make sure that the power cord is plugged into a properly grounded outlet. (See PLUGGING IN THE POWER CORD on pages 6 and 7.) If an extension cord is needed, use only a 14-gauge general-purpose cord of five feet or less in length.
- b. After the power cord has been plugged in, make sure that the safety key is fully inserted into the console. Various indicators on the console should light. (See TURNING ON THE POWER on page 8.)
- c. Check the circuit breaker located on the treadmill near the power cord. If the switch protrudes as shown, the circuit breaker has tripped. To reset the circuit breaker, wait for five minutes and then press the switch back in.
- d. Check the ON/OFF switch located on the treadmill near the power cord. The switch must be in the ON position.

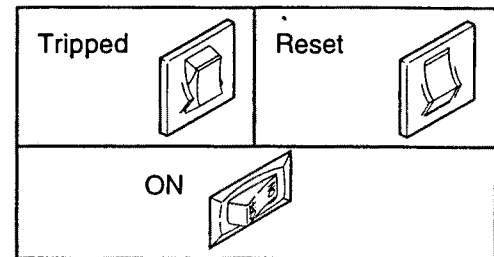

2. SYMPTOM: THE POWER TURNS OFF DURING USE

- a. Check the circuit breaker located on the treadmill near the power cord. If the circuit breaker has tripped (see the drawing above.), wait for five minutes and then press the switch back in.
- b. Make sure that the power cord is plugged in.
- c. Remove the safety key from the console. Reinsert the safety key fully into the console. Various indicators on the console should light.
- d. Check to make sure the ON/OFF switch is in the ON position. (See 1. d. above.)
- e. If the treadmill still will not run, please call our Customer Service Department.

3. SYMPTOM: THE PULSE EARCLIP DOES NOT FUNCTION PROPERLY

- a. Make sure that the pulse earclip is plugged fully into the jack on the console. Rub your left ear lobe and reposition the earclip. Attach the clothes clip to your collar.
- b. Stand still while measuring your pulse.
- c. The pulse earclip may need to be cleaned. Press the earclip open, and find the two clear circles inside the earclip. Wipe the two clear circles using a cotton swab moistened with water. **NOTE: Various factors, including the user's movement, may affect the accuracy of heart rate readings. The earclip is intended only as an exercise aid in determining heart rate trends in general.**

4. SYMPTOM: THE CONSOLE DOES NOT FUNCTION PROPERLY

- a. If a console malfunction occurs, an error code ("E1," "E2," "E3," etc.) may appear on the display. If an error code appears, remove the safety key, wait for ten seconds and then reinsert the safety key. If an error code appears again, call our Customer Service Department. Do not operate the treadmill until the problem is corrected.

5. SYMPTOM: THE WALKING BELT SLOWS WHEN WALKED ON

- a. The first time you use the treadmill, walk on the entire surface of the walking belt for 10 minutes to break in the walking platform. During this initial break-in period, it is normal for the walking belt to slow. (See BREAKING IN THE MAINTENANCE-FREE WALKING PLATFORM on page 7.)

b. If an extension cord is needed, use only a 14-gauge general-purpose cord of five feet or less in length.

c. If the walking belt is overtightened, treadmill performance may decrease and the walking belt may be permanently damaged. Remove the safety key and **UNPLUG THE POWER CORD**. Using the 3/16" allen wrench, turn both rear roller adjustment bolts counterclockwise, 1/4 of a turn. When the walking belt is properly tightened, you should be able to lift each side of the walking belt 3-4 inches off the walking platform. The center of the walking belt should just touch the walking platform. Be careful to keep the walking belt centered. Plug in the power cord, insert the safety key and run the treadmill for a few minutes. Repeat until the walking belt is properly tightened.

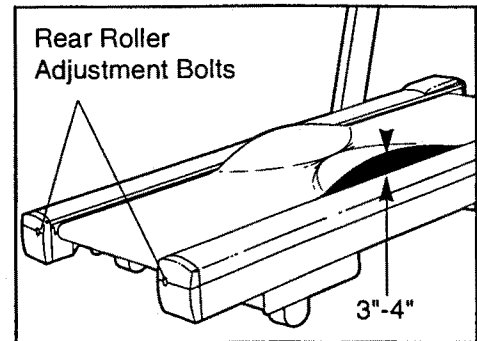

6. SYMPTOM: THE WALKING BELT IS OFF-CENTER OR SLIPS WHEN WALKED ON

a. If the walking belt has shifted to the left, first remove the safety key and **UNPLUG THE POWER CORD**. Using the 3/16" allen wrench, turn the left rear roller adjustment bolt clockwise, and the right bolt counterclockwise, 1/4 of a turn each. Be careful not to overtighten the walking belt. Plug in the power cord, insert the safety key and run the treadmill for a few minutes. Repeat until the walking belt is centered.

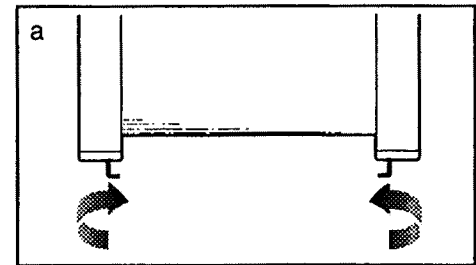

b. If the walking belt has shifted to the right, first remove the safety key and **UNPLUG THE POWER CORD**. Using the 3/16" allen wrench, turn the left rear roller adjustment bolt counterclockwise, and the right bolt clockwise, 1/4 of a turn each. Be careful not to overtighten the walking belt. Plug in the power cord, insert the safety key and run the treadmill for a few minutes. Repeat until the walking belt is centered.

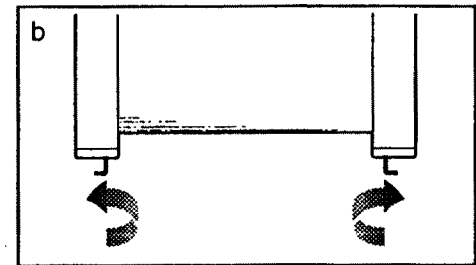

c. If the walking belt slips when walked on, first remove the safety key and **UNPLUG THE POWER CORD**. Using the 3/16" allen wrench, turn both rear roller adjustment bolts clockwise, 1/4 of a turn. When the walking belt is correctly tightened, you should be able to lift each side of the walking belt 3-4 inches off the walking platform. The center of the walking belt should just touch the walking platform. Be careful to keep the walking belt centered. Plug in the power cord, insert the safety key and run the treadmill for a few minutes. Repeat until the walking belt is properly tightened.

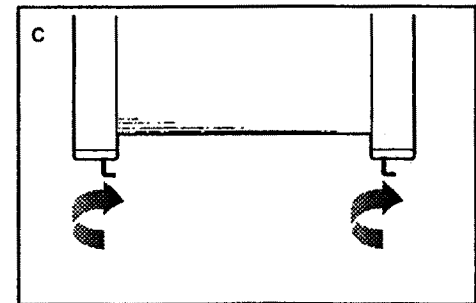

STORAGE

Unplug the power cord when the treadmill is not in use.

Using the 7/32" allen wrench, remove the bolt from the upper end of each upright (see drawing 1). Rotate the handrails down.

Remove one bolt and washer from the lower end of each upright (see drawing 2). Loosen the other bolt in the lower end of each upright. Carefully lower the uprights.

It is recommended that the treadmill be covered during extended periods of storage.

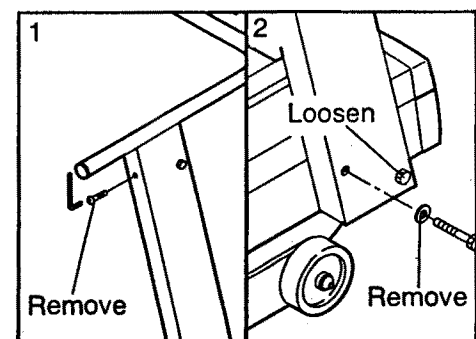

CONDITIONING GUIDELINES

The following guidelines will help you to plan your exercise program. Remember that proper nutrition and adequate rest are essential for successful results.

⚠ WARNING: Before beginning this or any exercise program, consult your physician. This is especially important for individuals over the age of 35 or individuals with pre-existing health problems.

EXERCISE INTENSITY

To maximize the benefits of exercising, it is important to exercise with the proper intensity. The proper intensity level can be found by using your heart rate as a guide. For effective aerobic exercise, your heart rate should be maintained at a level between 70% and 85% of your maximum heart rate as you exercise. This is known as your training zone. You can find your training zone in the table below.

AGE	UNCONDITIONED TRAINING ZONE (BEATS/MIN)	CONDITIONED TRAINING ZONE (BEATS/MIN)	AGE	UNCONDITIONED TRAINING ZONE (BEATS/MIN)	CONDITIONED TRAINING ZONE (BEATS/MIN)
20	138-167	133-162	55	127-155	122-149
25	136-166	132-160	60	126-153	121-147
30	135-164	130-158	65	125-151	119-145
35	134-162	129-156	70	123-150	118-144
40	132-161	127-155	75	122-147	117-142
45	131-159	125-153	80	120-146	115-140
50	129-156	124-150	85	118-144	114-139

During the first few months of your exercise program, keep your heart rate near the low end of your training zone as you exercise. After a few months of regular exercise, your heart rate can be increased gradually until it is near the middle of your training zone as you exercise. You can measure your heart rate using the pulse mode of the console. Exercise for at least four minutes, and then measure your heart rate immediately. If your heart rate is too high, decrease the intensity of your exercise. If your heart rate is too low, increase the intensity of your exercise.

⚠ WARNING: The pulse earclip is not a medical device. Various factors, including your movement during exercise, may affect the accuracy of heart rate readings. The earclip is intended only as an exercise aid in determining heart rate trends in general.

WORKOUT GUIDELINES

Each workout should consist of three basic parts: a warm-up, 20 to 30 minutes of training zone exercise, and a cool-down. Warming up prepares the body for exercise by increasing circulation, delivering more oxygen to the muscles and raising the body temperature. Begin each workout with 5 to 10 minutes of stretching and light exercise to warm up. Then, increase the intensity of your exercise to raise your heart rate to your training zone for 20 to 30 minutes. Breathe regularly and deeply as you exercise—never hold your breath. Finish each workout with 5 to 10 minutes of stretching to cool down. This will increase the flexibility of your muscles as well as help to decrease soreness and other post-exercise problems.

To maintain or improve your condition, complete three workouts each week, with at least one day of rest between workouts. After a few months of regular exercise, you may complete up to five workouts each week, if desired. The key to success is CONSISTENCY.

SUGGESTED STRETCHES

The following stretches can provide a good warm-up or cool-down. Correct form for each stretch is shown in the drawings below. Move slowly as you stretch—never bounce.

TOE TOUCH STRETCH

Stand with your knees bent slightly and slowly bend forward from your hips. Allow your back and shoulders to relax as you reach down toward your toes as far as possible. Hold for 15 counts, then relax. Repeat 3 times.

Stretches: Hamstrings, back of knees and back.

HAMSTRING STRETCH

Sit with one leg extended. Bring the sole of the opposite foot toward you and rest it against the inner thigh of your extended leg. Reach toward your toes as far as possible. Hold for 15 counts, then relax. Repeat 3 times for both legs.

Stretches: Hamstrings, lower back and groin.

CALF/ACHILLES STRETCH

With one leg in front of the other, reach forward and place your hands against a wall. Keep your back leg straight and your back foot flat on the floor. Bend your front leg, lean forward and move your hips toward the wall. Hold for 15 counts, then relax. Repeat 3 times for both legs. To cause further stretching of the achilles tendons, bend your back leg as well.

Stretches: Calves, achilles tendons and ankles.

QUADRICEPS STRETCH

With one hand against a wall for balance, reach back and grasp one foot with your other hand. Bring your heel as close to your buttocks as possible. Hold for 15 counts, then relax. Repeat 3 times for both legs.

Stretches: Quadriceps and hip muscles.

INNER THIGH STRETCH

Sit with the soles of your feet together and your knees outward. Pull your feet toward your groin area as far as possible. Hold for 15 counts, then relax. Repeat 3 times.

Stretches: Quadriceps and hip muscles.

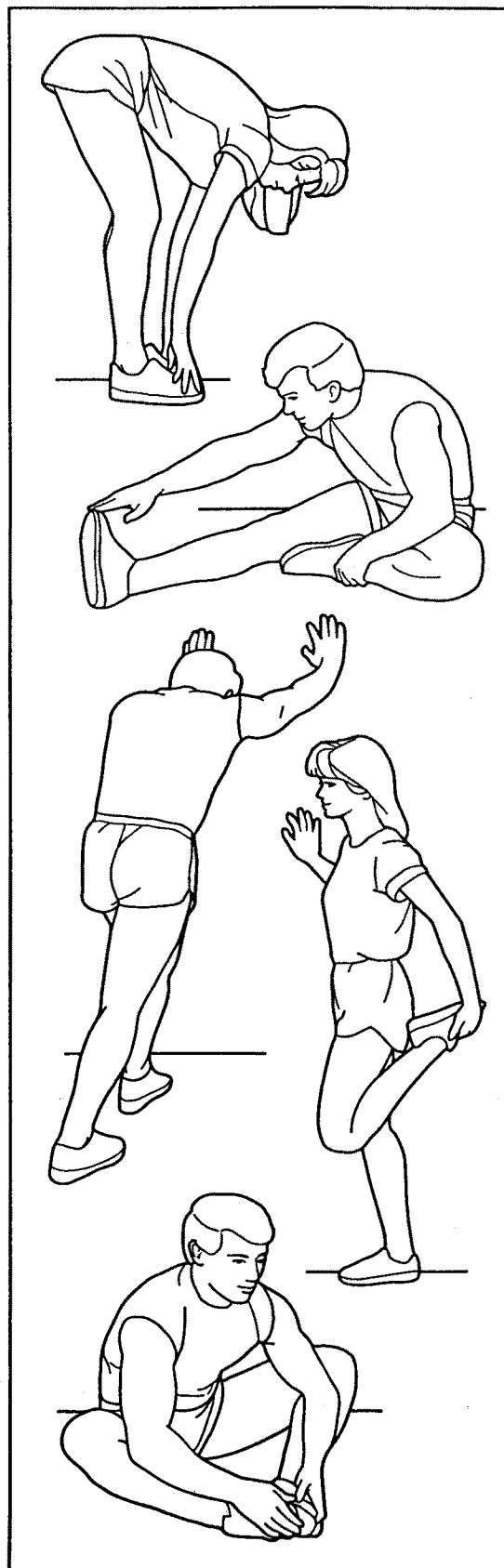

PART LIST—Model No. PFTL10041

R1294A

Key No.	Qty.	Description	Key No.	Qty.	Description
1	2	Handrail Lock Bolt	54	2	Incline Motor Bolt
2	1	Left Upright	55	1	Incline Motor
3	2	3/8" x 1" Bolt	56	1	Incline Motor Spacer
4	1	Safety Key/Clip	57	2	Optic Switch Wire Harness
5	2	Handrail Cap	58	4	Endcap Screw
6	6	Cage Nut	59	4	Cushion Foot Bolt
7	1	Handrail	60	2	Cushion Foot
8	7	Console Screw	61	1	Right Rear Endcap
9	1	Console	62	2	Rear Roller Adjustment Bolt
10	1	Pulse Earclip/Clothes Clip	63	1	4" Cable Tie
11	1	Handrail Wire Harness	64	1	8" Cable Tie
12	1	Front Left Endcap	65	1	Tie Block
13	1	Front Roller/Pulley	66	2	Cover Washer
14	1	Right Foot Rail	67	1	3/16" Allen Wrench
15	1	Front Right Endcap	68	1	Wrench Clip
16	1	Right Upright	69	1	Rear Roller
17	1	Front Roller Adjustment Bolt	70	1	Left Rear Endcap
18	3	Roller Adjustment Washer	71	8	Platform Screw
19	4	Flat Washer	72	1	Walking Platform
20	4	3/8" x 3 1/4" Bolt	73	1	Left Foot Rail
21	19	Safety Cover Screw	74	1	Motor Swivel Bolt
22	1	20" Wire Harness	75	1	Motor Tension Nut
23	1	Belt Guide	76	1	Motor Mounting Bracket
24	9	Screw	77	1	Pulley/Flywheel/Fan
25	2	12" Cable Loom	78	1	Motor Belt
26	1	14" Power Board-Controller Wire	79	2	Motor Bolt
27	1	Choke	80	1	Motor
28	1	Electronics Bracket	81	1	Speed Optic Disk
29	1	Grommet	82	1	Optic Switch Bracket
30	1	Circuit Breaker	83	1	Optic Switch Bracket Nut
31	1	On/Off Switch	84	2	Motor Nut
32	1	Power Cord	85	1	Wire Cover
33	2	Front Wheel Bolt	86	2	Cushion Foot Cover
34	2	Front Wheel	87	2	Deck Shim
35	1	Controller	88	1	Choke Bracket
36	1	Power Cord Bracket	89	7	Small Hex Screw
37	1	Safety Cover Bracket	90	2	6" Cable Loom
38	6	Wheel Nut/Cushion Foot Nut	91	1	7/32" Allen Wrench
39	3	Incline Leg Bolt/Motor Tension Bolt	92	1	Cable Tie
40	5	Incline Leg Nut/Motor Tension Nut	93	2	Incline Leg Washer
41	1	Incline Leg	94	2	Star Washer
42	1	Power Board	95	2	Upright Spacer
43	1	Switch Star Washer	96	6	Foot Rail Shim
44	4	Plastic Stand-Off	97	1	Motor Tension Washer
45	1	Frame	#	1	8" White Wire, Male/Female
46	1	Front Safety Cover	#	1	14" White Wire, 2 Female
47	1	Back Safety Cover	#	1	8" Black Wire, 2 Female
48	1	Walking Belt	#	1	4" Black Wire, Male/Female
49	2	Small Nut	#	1	4" Black Wire, 2 Female
50	2	Optic Switch	#	1	8" Green Ground Wire
51	2	Small Bolt	#	1	8" Red Wire, Male/Female
52	1	Incline Optic Disk	#	1	8" Blue Wire, 2 Female
53	1	Incline Motor Bracket	#	1	Owner's Manual

Note: "#" indicates a non-illustrated part. Specifications are subject to change without notice. See the back cover for information about ordering replacement parts.

EXPLODED DRAWING—Model No. PFTL10041

R1294A

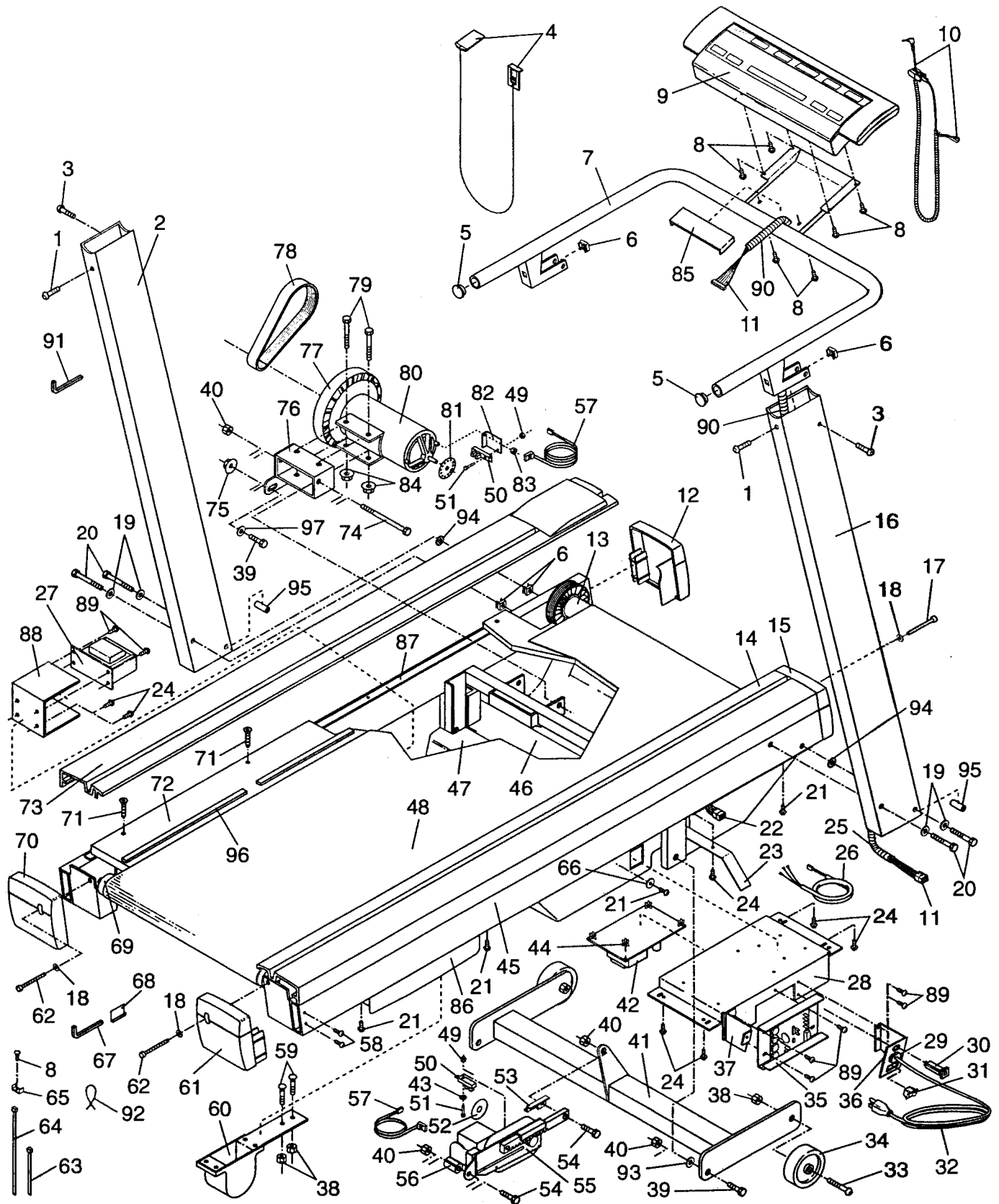

ORDERING REPLACEMENT PARTS

To order replacement parts, call our Customer Service Department toll-free at **1-800-999-3756**, Monday through Friday, 6 a.m. until 6 p.m. Mountain Time (excluding holidays). When ordering parts, please be prepared to give the following information:

- The **MODEL NUMBER** of the product (PFTL10041).
- The **NAME** of the product (PROFORM® 520 treadmill).
- The **SERIAL NUMBER** of the product (see the front cover of this manual).
- The **KEY NUMBER** of the part(s) from page 14 of this manual.
- The **DESCRIPTION** of the part(s) from page 14 of this manual.