

Product Manual

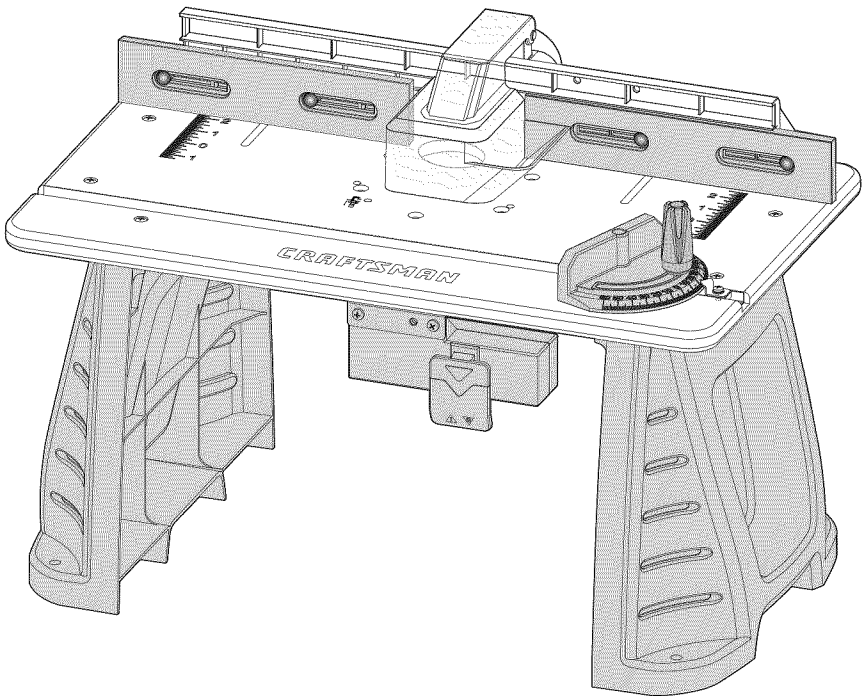

Router Table

Model No. 320. 28160



▲ CAUTION! Read, understand and follow all Safety Rules and Operating Instructions in this Manual before using this product.

- **Warranty**
- **Safety**
- **Assembly**
- **Operation**
- **Maintenance**

Sears, Roebuck and Co., Hoffman Estates, IL 60179

www.craftsman.com

TABLE OF CONTENTS

Warranty	Page 2
Safety Symbols	Pages 3-4
Safety Instructions	Pages 5-10
Know Your Router Table	Pages 11-12
Unpacking and Checking Contents	Page 12
Parts list	Page 13
Assembly	Pages 14-17
Operation	Pages 17-21
Maintenance	Pages 22
Troubleshooting	Pages 22
Parts list	Pages 23-24
Sears Repair Parts Phone Numbers	Back Cover

ONE YEAR FULL WARRANTY ON CRAFTSMAN® TOOL

If this Craftsman tool fails to give complete satisfaction within one year from the date of purchase, return it to any Sears store or parts & repair center or other Craftsman outlet in the United States for free repair (or replacement, if repair proves impossible).

This warranty does not include expendable parts such as lamps, batteries, bits, or blades.

This warranty applies for only 90 days from the date of purchase if this product is ever used for commercial or rental purposes.

This warranty gives you specific legal rights, and you may also have other rights, which vary from state to state.

Sears, Roebuck and Co., Hoffman Estates, IL 60179

⚠ WARNING: Some dust created by using power tools contains chemicals known to the state of California to cause cancer and birth defects or other reproductive harm.

SAVE THESE INSTRUCTIONS!

READ ALL INSTRUCTIONS!

SAFETY SYMBOLS

The purpose of safety symbols is to attract your attention to possible dangers. The safety symbols, and the explanations with them, deserve your careful attention and understanding. The symbol warnings **DO NOT**, by themselves, eliminate any danger. The instructions and warnings they give are no substitutes for proper accident-prevention measures.

 **WARNING:** BE SURE to read and understand all safety alert symbols, such as “DANGER,” “WARNING,” and “CAUTION” BEFORE using this product. Failure to follow all instructions may result in electric shock, fire, and/or serious personal injury.

SYMBOL MEANINGS

 **SAFETY ALERT SYMBOL:** Indicates DANGER, WARNING, OR CAUTION. May be used in conjunction with other symbols or pictographs.

 **DANGER:** Failure to obey this safety warning **WILL** result in death or serious injury to yourself or to others. Always follow the safety precautions to reduce the risk of fire, electric shock and personal injury.

 **WARNING:** Failure to obey this safety warning **CAN** result in death or serious injury to yourself or to others. Always follow the safety precautions to reduce the risk of fire, electric shock and personal injury.











 **CAUTION:** Failure to obey this safety warning **MAY** result in personal injury to yourself or others or property damage. Always follow the safety precautions to reduce the risk of fire, electric shock and personal injury.

DAMAGE PREVENTION AND INFORMATION MESSAGES

These inform the user of important information and/or instructions that could lead to equipment or other property damage if they are not followed. Each message is preceded by the word “**NOTE**,” as in the example below:

NOTE: Equipment and/or property damage may result if these instructions are not followed.

Some of these following symbols may be used on this tool. Please study them and learn their meaning. Proper interpretation of these symbols will allow you to operate the tool better and more safely.

SYMBOL	NAME	DESIGNATION / EXPLANATION
V	Volts	Voltage
A	Amperes	Current
Hz	Hertz	Frequency (cycles per second)
w	Watt	Power
min	Minutes	Time
~	Alternating Current	Type of current
≡	Direct Current	Type or a characteristic of current
n ₀	No Load Speed	Rotational speed, at no load
	Class II Construction	Double-insulated construction
.../min	Per Minute	Revolutions, strokes, surface speed, orbits, etc., per minute
	Wet Conditions Alert	Do not expose to rain or use in damp locations.
	Read the Product Manual	To reduce the risk of injury, user must read and understand product manual before using this product.
	Eye Protection	Always wear safety goggles or safety glasses with side shields and a full-face shield when operating this product.
	Safety Alert	Precautions that involve your safety.
	No Hands Symbol	Failure to keep your hands away from the blade will result in serious personal injury.
	No Hands Symbol	Failure to keep your hands away from the blade will result in serious personal injury.
	No Hands Symbol	Failure to keep your hands away from the blade will result in serious personal injury.
	No Hands Symbol	Failure to keep your hands away from the blade will result in serious personal injury.
	Hot Surface	To reduce the risk of injury or damage, avoid contact with any hot surface.

SAFETY INSTRUCTIONS

⚠ WARNING: READ AND UNDERSTAND ALL INSTRUCTIONS. Failure to follow all instructions listed below and the instructions in the product manual for your router may result in serious personal injury.

WORK AREA SAFETY

- **Keep the work area clean and well lit.** Cluttered benches and dark areas invite accidents.
- **Don't use in a dangerous environment.** Don't use power tools in damp or wet locations or expose them to rain. Don't operate power tools in potentially explosive environments, such as in the presence of flammable liquids, gases, or dust. Power tools create sparks, which may ignite the dust or fumes.
- **Operate the tool in well-ventilated areas,** and provide proper dust removal. Dust generated from some materials can be hazardous to your health. Use dust-collection systems whenever possible.
- **Keep children and bystanders away.** All visitors should be kept a safe distance away from the work area.
- **Use the right tool.** Don't force a tool or attachment to do a job for which it was not designed.
- **Make the workshop kid-proof** with padlocks, master switches, or by removing starter keys.

ELECTRICAL SAFETY

Grounded tools

- In the event of a malfunction or breakdown, grounding provides a path of least resistance for electric current to reduce the risk of electric shock. This router table is equipped with an electrical cord having an equipment-grounding conductor and a grounding plug. The plug must be plugged into a matching outlet that is properly installed and grounded in accordance with all local codes and ordinances.
- Do not modify the plug provided. If it will not fit into the outlet, have the proper outlet installed by a qualified electrician.
- Improper connection of the equipment-grounding conductor can result in a risk of electric shock. The conductor with a green-colored outer insulation cover, with or without yellow stripes, is the equipment-grounding conductor. If repair or replacement is necessary, do not connect the equipment-grounding conductor to a live terminal.
- Check with a qualified electrician or service personnel if the grounding instructions are not completely understood, or if in doubt as to whether the tool is properly grounded.

- Use only 3-wire extension cords that have 3-prong grounding plugs and 3-pole receptacles that accept the tool's plug.
- Repair or replace a damaged or worn cord immediately.

Repair or replace damaged or worn cord immediately.

This tool is intended for use on a circuit that has an outlet that looks like the one illustrated in Sketch A in the figure below. The tool has a grounding plug that looks like the plug illustrated in sketch A in the figure below. A temporary adapter, which looks like the adapter illustrated in Sketches B and C, may be used to connect this

plug to a 2-pole receptacle as shown in Sketch B if a properly grounded outlet is not available. The temporary adapter should be used only until a properly grounded outlet can be installed by a qualified electrician. The green-colored rigid ear, lug, and the like, extending from the adapter must be connected to a permanent ground, such as a properly grounded outlet box.

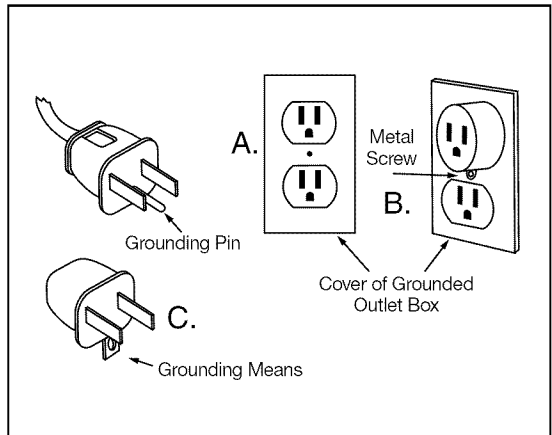

Double-insulated tools

The fixed-base router that is included with the router table is a double-insulated tool.

Carefully read and understand all instructions for the fixed-base router before operating the tool.

- Replacement parts: When servicing use only identical replacement parts.
- Polarized plugs: To reduce the risk of electric shock, this equipment has a polarized plug (one blade is wider than the other). This plug will fit in a polarized outlet only one way. If the plug does not fit fully in the outlet, reverse the plug. If it still does not fit, contact a qualified electrician to install the proper outlet. Do not change the plug in any way.

Use the proper extension cord.

- Make sure that your extension cord is in good condition.
- When using an extension cord, be sure to use one heavy enough to carry the current your product will draw. An undersized cord will cause a drop in line voltage resulting in loss of power and overheating.

- Table A shows the correct size to use, depending on cord length and ampere rating. If in doubt, use the next heavier gauge: the smaller the gauge number, the heavier the cord.
- When operating a power tool outdoors, ALWAYS use an outdoor extension cord marked “W-A” or “W.” These cords are rated for outdoor use and reduce the risk of electric shock.

Minumum Gauge for Extension Cords				
Volts	Total Length of Cord in Feet			
120V	0-25ft.	25-50ft.	51-100ft.	101-150ft.
Ampere Rating	AWG	AWG	AWG	AWG
More than 0 Not more than 6	18	16	16	14
More than 6 Not more than 10	18	16	14	12
More than 10 Not more than 12	16	16	14	12
More than 12 Not more than 16	14	12	Not Recommended	

PERSONAL SAFETY

⚠ WARNING: Use of this product can generate dust containing chemicals known to the state of California to cause cancer, birth defects or other reproductive harm. Some examples of these chemicals are:

- Lead from lead-based paints.
- Crystalline silica from bricks and cement and other masonry products.
- Arsenic and chromium, from chemically treated lumber.

Your risk from these exposures varies, depending upon how often you do this type of work. To reduce your exposure to these chemicals:

- Work in a well-ventilated area.
- Work with approved safety equipment, such as those dust masks that are specially designed to filter out microscopic particles.

Avoid prolonged contact with dust from power sanding, sawing, grinding, drilling and other construction activities. Wear protective clothing and wash exposed areas with soap and water. Allowing dust to get into your mouth, eyes or lay on the skin may promote absorption of harmful chemicals.

⚠ WARNING: The operation of any power tool can result in foreign objects being thrown into your eyes, which can result in severe eye damage. Before beginning power-tool operation, always wear safety goggles or safety glasses with side shields, and a full-face shield when needed. We recommend Wide Vision Safety Mask for use over eyeglasses or standard safety glasses with shields. Always use eye protection that is marked to comply with ANSI Z87.1

- **Stay alert, watch what you are doing, and use common sense** when operating a power tool. Do not use the tool while tired or under the influence of drugs, alcohol, or medication.
- **Wear proper apparel.** Do not wear loose clothing, gloves, neckties, rings, bracelets, or other jewelry which may get caught in moving parts. Non-slip footwear is recommended. Wear protective hair covering to contain long hair.
- **Keep your hair, clothing, and gloves away from moving parts.**
- **Remove adjusting keys and wrenches.** Form a habit of checking to see that keys and adjusting wrenches are removed from the tool before turning it on.
- **Always use safety glasses.** Also use face or dust mask if cutting operation is dusty. Everyday glasses may have impact-resistant lenses, but they are NOT safety glasses.
- **Never touch the pins of the electrical plug** while inserting it into or removing it from an electrical socket.
- **Never stand on tool.** Serious injury could occur if the tool is tipped, or if the cutting tool is unintentionally contacted.



TOOL USE AND CARE SAFETY

- **Use recommended accessories.** Consult the owner's manual for recommended accessories. The use of improper accessories may cause risk of injury to persons.
- **Keep guards in place and in working order.**
- **Secure work.** Use clamp or a vise to hold work when practical. It is safer than using your hand and it frees both hands to operate tool.
- **Recuse the risk of unintentional starting.** Be sure the switch is in the "OFF" position before plugging the tool into an electrical outlet.
- **Do not use a tool if the switch does not turn it "ON" or "OFF".** Any tool that cannot be controlled with the switch is dangerous and must be repaired.
- **Do not carry tools with your finger on the switch.**
- **Do not overreach.** Keep proper footing and balance at all times.

- **Do not force the tool.** Use the correct tool and blade for your application. The correct tool and cutter will do the job better and more safely at the rate for which it is designed.
- **Disconnect tools** before servicing; when changing accessories, such as blades, bits, cutters, and the like.
- **Store idle tools out of the reach of children** and other untrained people.
- **Never leave the tool running unattended;** turn the power off. Don't leave the tool until it comes to a complete stop.
- **Always maintain tools with care.** Keep cutting tools sharp and clean. Properly maintained tools with sharp cutting edges are less likely to bind and are easier to control. Follow all instructions for lubricating and changing accessories.
- **Check for damaged parts.** Before further use of the tool, a guard or other part that is damaged should be carefully checked to determine that it will operate properly and perform its intended function. Check for alignment of moving parts, binding of moving parts, mounting, and any other conditions that may affect its operation. A guard or other part that is damaged should be properly repaired or replaced.
- **Direction of feed.** Feed work into a blade or cutter against the direction of rotation of the blade or cutter only.

SERVICE SAFETY

- Tool service **MUST** be performed only by qualified repair personnel. Service or maintenance performed by an unqualified person could result in a risk of injury
- Use only identical replacement parts when servicing a power tool.
- Follow the instructions in the Maintenance section of this Product Manual. Use of unauthorized parts or failure to follow Maintenance Instructions may create a risk of electric shock or injury.

SPECIFIC SAFETY FOR THE ROUTER TABLE

- **Read and understand the router table and the instructions and warnings in the product manuals for the router table and the router.** Failure to follow all instructions and warnings may result in serious personal injury.
- **Fully assemble and tighten all fasteners** required for this table and for mounting the router to the table. Do not use the router table until all assembly and installation steps have been completed. Before each use, check the stand and the router to make sure that all fasteners are still tight. A loose stand is unstable and may shift in use.
- **Unplug the router before installing it into the table,** Turn off the router-table safety switch controlling power to the the router, or unplug the router before making adjustments or changing accessories, such as bits or cutters.

- **Do not plug the router power cord into a wall outlet.** It must be plugged into the router table switch. Power tool switches and controls need to be within your reach in emergency situations.
- Before operating, **make sure that the entire unit** (table with router installed) **is placed on and secured to a solid, flat, level surface** and that it will not tip.
- **Use of auxiliary infeed and outfeed supports** is necessary for long or wide work pieces. Long work pieces without adequate support can flip off the table or cause the table to tip over.
- **Do not use the router table without the bit guard.** Remove all dust, chips, and any other foreign particles that can affect its function. Adjust the guard height so that it clears the router bit and work piece. The guard will aid in keeping hands from unintended contact with the rotating bit.
- **Never place your fingers** near a spinning bit or under the guard when the router is plugged in.
- **Never hold the work piece on the outfeed side of the bit.** Pressing the work piece against the out-feed side of the fence may cause the material to bind, which may cause kickback and pull your hand back into the bit.
- **Guide the work piece against the fence** to maintain control of the work piece. Do not place material between the router bit and the fence while routing the edge. This placement will cause the material to become wedged, possibly causing kickback.
- **Routers are intended for working with wood, wood-like products, and plastic or laminates,** not for cutting or shaping metals.
- **Be sure the work piece does not contain nails, etc.** Cutting nails may cause loss of control.
- **Do not use bits with cutting diameters that exceed the clearance hole** in the tabletop insert. The bit could contact the inset ring, throwing fragments.
- **Install the bit in accordance with the instructions** in the router manual and securely clamp the router bit in the collet chuck before making any cuts.
- **Never use dull or damaged bits.** Sharp bits must be handled with care. Damaged bits can snap during use. Dull bits require more force to push the work piece, possibly causing the bit to break or the material to kickback.
- **The router table is designed to cut flat, straight, and squared material.** Do not cut material that is warped, wobbly, or otherwise unstable. If the material is slightly curved, but otherwise stable, cut the material with the concave side against the table or fence. Cutting the material with the concave side up or away from the fence may cause the warped or wobbly material to roll and kick back, causing the user to lose control.
- **Never start the tool when the bit is engaged in the material.** The cutting edge may grab the material, causing loss of control of the work piece.

KNOW YOUR ROUTER TABLE

Your router table has a precision-built electric switch box and it should be connected to only a 120-volt, 60-HZ AC power supply (normal household current). DO NOT operate on direct current (DC). The large voltage drop would cause a loss of power and the motor would overheat. If the router table does not operate when plugged into correct 120-volt, 60-HZ AC ONLY outlet, check the power supply. The router table comes with an 8-ft. power cord (no adapter needed).

This Router Table has the following features:

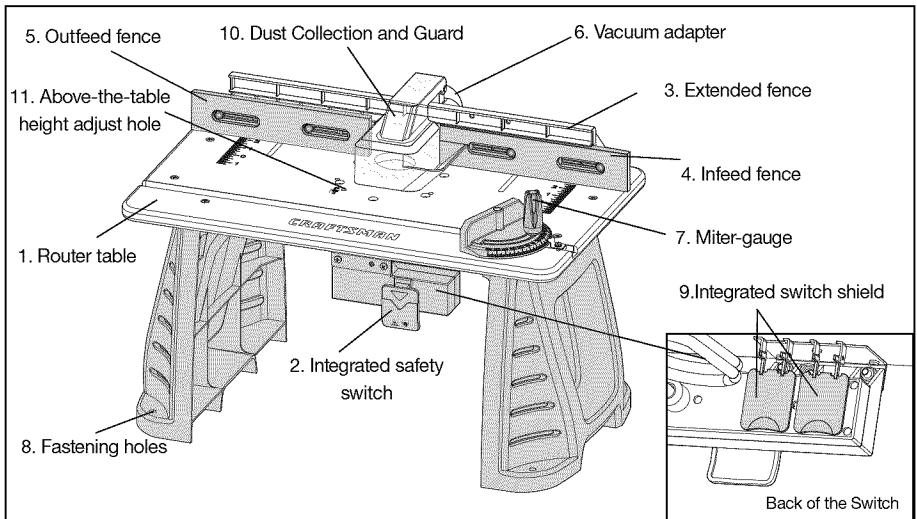

1. **Oversized table** (14-1/8" x 23-5/8") for a large, smooth, durable, work surface and improved sound absorption. Table height clearance is 11-1/4 in. to accommodate most fixed and plunge-based routers
2. **Integrated safety switch with two outlets.** To ensure safety and reliability, when one receptacle in use of the router, another receptacle's capacity must be less than 5 Amps. The total current of two units must be less than 15 Amps.
3. **Extended fence** provides maximum work piece support; the fence can be moved forward and backward 3-3/4 inch.
4. **Infeed and outfeed fence** can each be extended 2 in.
5. **Outfeed fence** can be adjusted as much as 9/16-in. forward of the infeed fence for joining operations.
6. **Vacuum adapter** fits a 2-1/2 inch shop vacuum hose.
7. **Miter-gauge** adjusts from 0° to 60° in both directions for increased stability in many difficult feed situations.

8. **Fastening holes** (11/32-inch dia.) allow the Router Table to be fixed to a stable work surface.
9. **Integrated switch shield** prevents dust from accumulating in the sockets.
10. **Dust Collection/Guard** reduces dust dispersal.
11. **Above-the-table height adjustment:** the bit height can be adjusted by turning the adjustment knob clockwise or counterclockwise with a hex wrench (5 inches long and 5mm in diameter, not included). This feature functions only when using the Craftsman router supplied with this table (model 17541) or the following Craftsman routers: models 17542 and 17543.

UNPACKING AND CHECKING CONTENTS

⚠ WARNING: If any parts are missing, DO NOT attempt to assemble, install, or use your router table until the missing parts have been found or replaced and your router table has been properly and correctly assembled according to this product manual.

- In order to simplify handling and to minimize any damage that may occur during shipping, your router table comes partially assembled.
- Separate all parts from the packaging materials and check each part against the illustration and the parts list on page 13 to make sure that all parts have been included. Do this before discarding any of the packaging material.

PARTS LIST

Key NO.	Description	Quantity
1	Router table surface assembly	1
2	Table leg	2
3	Fence assembly	1
4	Miter-gauge assembly	1
5	Clamping knob	3
6	Short, round-head, square-neck bolts	2
7	Long pan-head screw	4
8	Short pan-head screw	4
9	Flat-head screw	3
10	Small nut	8
11	Plain washer	2
12	Small washer	16
13	Spring washers	8

Fig. 1

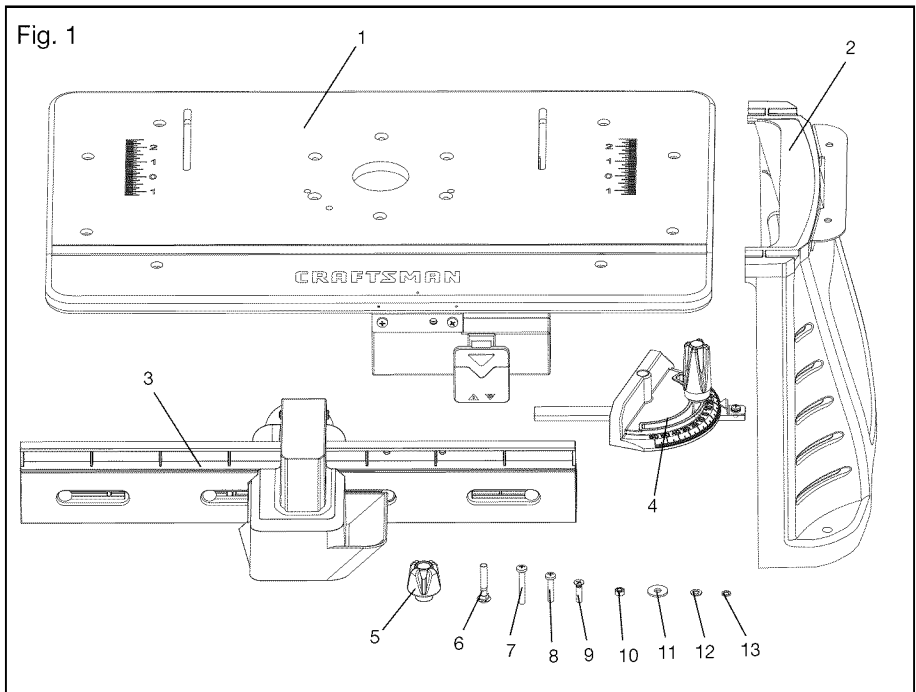

ASSEMBLY

ATTACHING THE LEGS TO THE TABLE TOP

1. Place the router table surface upside down on a flat, level surface, with the underside of the table facing up.
2. Position the legs relative to the router table as shown in Fig. 2.
3. Position one short end of the table so that it extends beyond the edge of your work surface far enough to gain access to the four holes in that end of the router-table top.
4. Align the two outermost holes on the table top with the holes in the leg bracket.

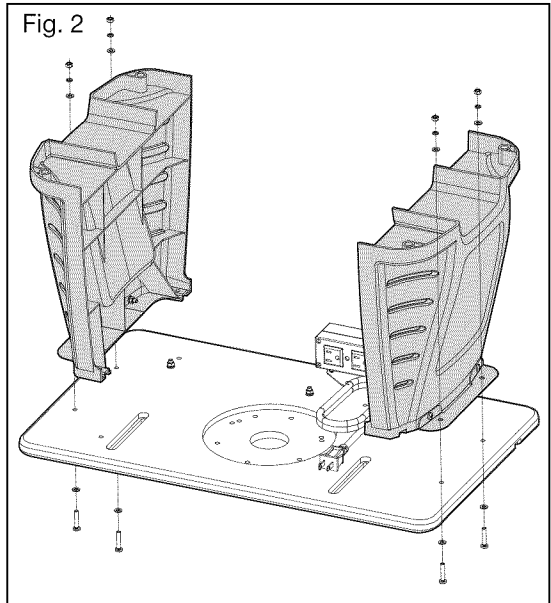

5. Place a flat washer (12) onto each of two short, pan-head screws (8). Insert the short, pan-head screws up through the holes in the table and through the holes in the leg bracket. Place a small washer (12), a spring washer (13), and small nut (10) on the threads of the screw. Loosely tighten the nuts. (Fig. 2)
6. Place a flat washer (12) onto each of two long, pan-head screws (7). Insert the long, pan-head screws up through the other two holes on the table top and through the corresponding holes in the leg. Place a small washer (12), a spring washer (13), and small nut (10) on the threads of the screw. (Fig. 3)
7. Securely tighten all fasteners.
8. Repeat with the other leg.

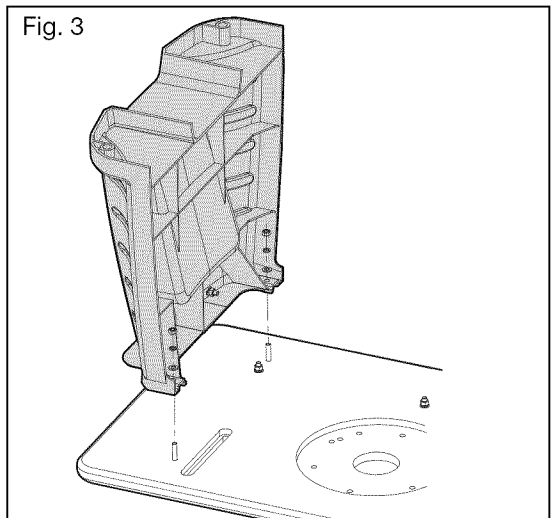

ATTACHING THE ROUTER TO THE TABLE

Attach the router to the router table after you have assembled the table.

1. Place the router table upright, with the front edge closest to you.
2. Be sure that the table is stable and that it rests on all four legs.
3. Remove the sub-base from the fixed-based router supplied.
4. Hold the router upside down, and align the three holes in the center of the table with the holes in the router, as shown in Fig. 4. Position the router so that the screw holes used for attachment are not directly above either of the router handles.
5. Insert a flat-head screw through each of the three router-table holes into the router holes.
6. Hold the router with one hand, and securely tighten each flat-head screw (9) with the other hand.

If you install a different router (one not supplied to the table), ensure that the diameter of the router sub-base does not exceed 6-7/8 inches. Six mounting holes for the router are distributed in the center of the table; the distance between two opposite holes is 5-3/8". Select three appropriate holes to mount the router to the table. (Fig. 5)

The adjusting hole in the table, shown in Fig. 5, is for cutting height adjustment of the router supplied (Model No. 17541) or the following Craftsman routers: 17542 and 17543.

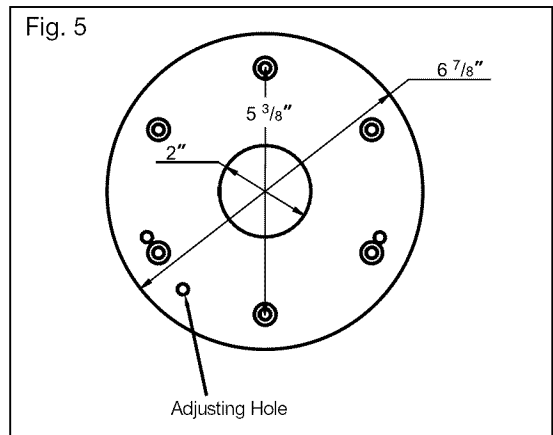
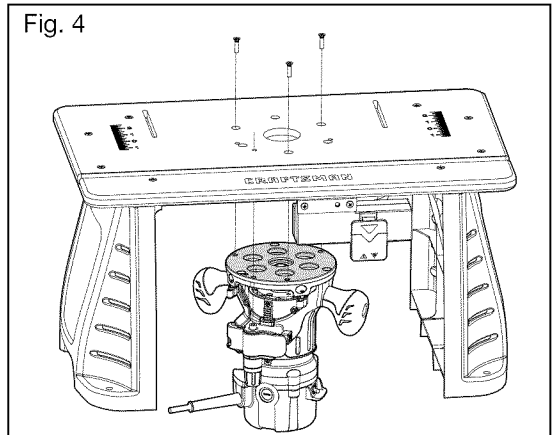

ATTACHING THE FENCE TO THE TABLE (Fig. 6)

⚠ WARNING: Always unplug the router before attaching or removing the fence. The fence has been shipped completely assembled.

1. Place the fence assembly on the table with the four wing nuts facing toward you.
2. Align the two holes on the bottom of fence assembly with the two channels on the router table.
3. Secure the fence to the table with two clamping knobs (5), two plain washers (11), and two short, round-head, square-neck bolts (6).

TO ATTACH THE MITER GAUGE (Fig. 7)

The miter gauge has been shipped completely assembled.

Attach the miter gauge to the table by placing the miter-gauge bar in the slot on the table.

MOUNTING THE TABLE TO A WORK SURFACE (See Fig. 8)

1. Place the router table, upright, on a sturdy surface, e.g., work stand, work-bench, or counter top.
2. While holding the router table in place, mark on the work surface the location of the two mounting holes (11/32-in dia.) in each of the legs.
3. Remove the router table.

Fig. 6

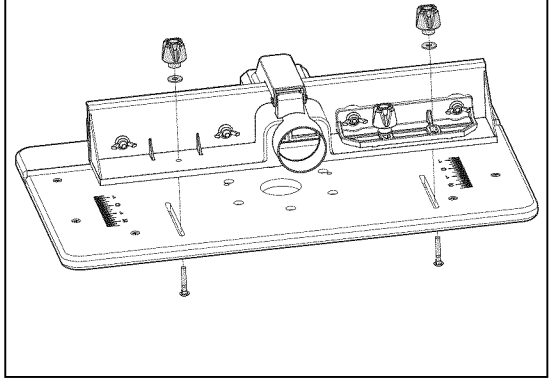

Fig. 7

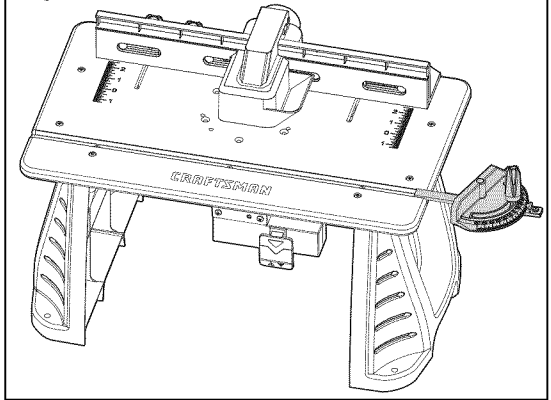
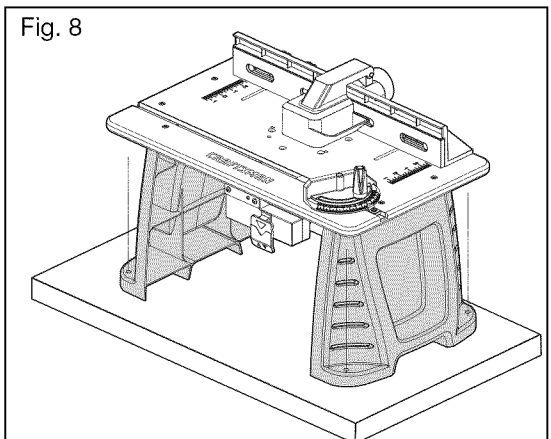

Fig. 8



4. Drill a hole at each of the marked locations.
5. Place the router table on the work surface, and align the holes in the table legs with the holes in the work surface.
6. Secure the router table to the work surface using four screws (not supplied).
7. Securely tighten the screws.

OPERATION

SWITCH OPERATION

The switch has a safety key to help prevent accidentally switching the router ON and the unauthorized, possibly hazardous use by others.

The safety key must be completely inserted into the switch before the switch can be turned ON.

To operate the switch:

1. Insert the safety key into the switch. (Fig. 9)
2. To turn the router ON, pull out the ON/OFF switch. (Fig. 10)

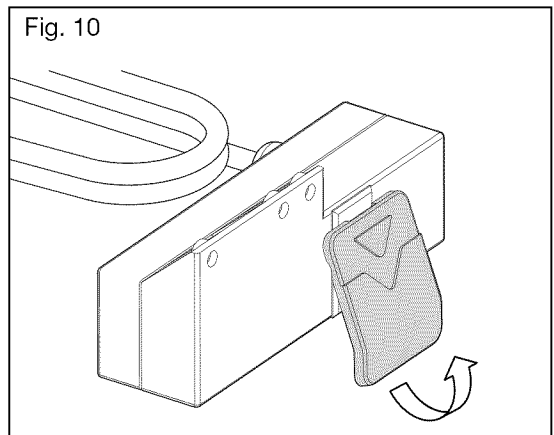
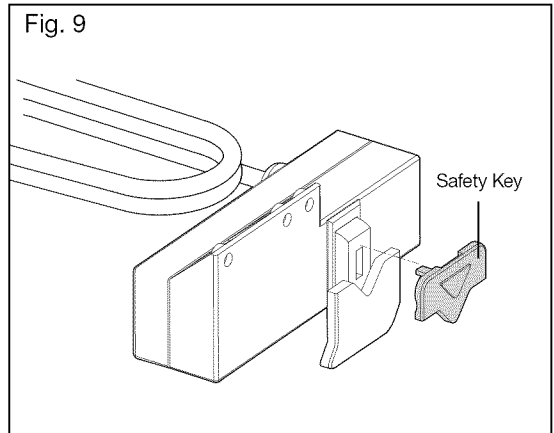

3. To turn the router OFF, push the ON/OFF switch down. (Fig. 11)

⚠ WARNING: Never leave the router unattended while it is running or before it comes to a complete stop.

4. To lock switch in the OFF position, push the ON/OFF switch down to turn the switch OFF, and remove the safety key from the switch.

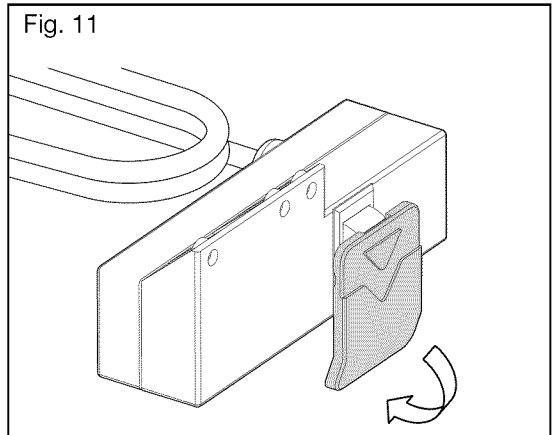

Two receptacles are located at the back of the switch assembly (Fig. 12). Use one for plugging in the router. The other may be used to plug in a vacuum or a light (not included). Two dust shields are designed to protect the receptacles.

⚠ WARNING: To ensure safety and reliability, when one receptacle in use of the router, another receptacle's capacity must be less than 5 Amps. The total current of two units must be less than 15 Amps.

NOTE: The vacuum adapter in the fence assembly is 2-1/2 in. in diameter; select the vacuum accordingly.

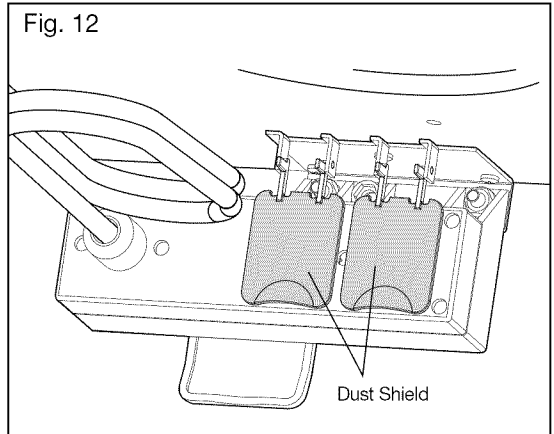

ADJUSTING THE FENCE

The fence enables you to support and guide the work piece.

To adjust the extended fence forward and backward (Fig. 13)

1. Loosen the two clamping knobs (5).
2. Move the fence forward or backward along the slots to the desired position.
3. Tighten the clamping knobs. The fence can be moved forward and backward 3-3/4 in.

Fig. 13

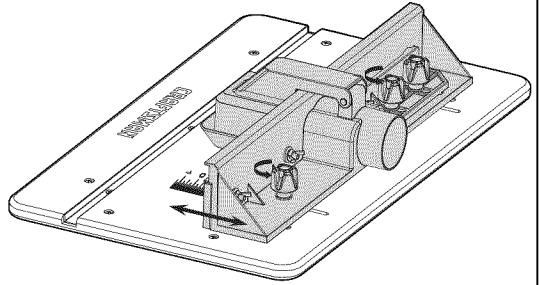

To laterally adjust the infeed and outfeed fence

The infeed and outfeed fence can each be adjusted 2 inches in order to lengthen the fence.

1. Loosen the four wing nuts.
2. Move the fence facings right or left to the desired position. (Fig. 14)
3. Tighten the wing nuts.

Fig. 14

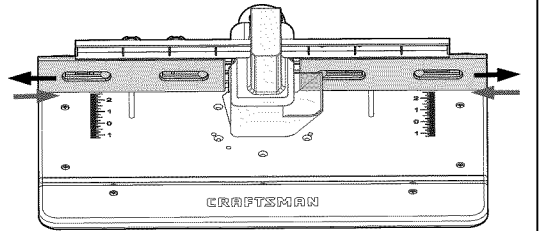

To adjust the outfeed fence for joining (Fig. 15)

For joining operations, the outfeed fence can be adjusted as much as 9/16-inch forward of the infeed fence to support the work piece after it passes across the router bit.

1. Loosen the two outfeed fence clamping knobs.
2. Move the outfeed fence forward of the infeed fence to the width of material you want to remove from the work piece. Tighten the clamping knobs.
3. Move and clamp the entire extended fence so that the outfeed fence is aligned with the cutting edge of the bit.

Fig. 15

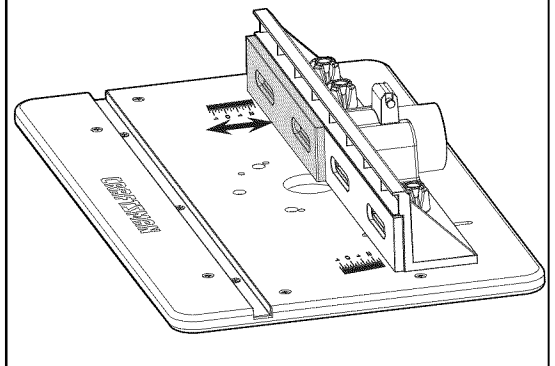

ADJUSTING THE MITER GAUGE (Fig. 16)

1. Loosen the miter gauge knob.
2. Rotate the miter gauge to the desired angle.
3. Tighten the miter gauge knob.

ADJUSTING THE CUTTING HEIGHT

NOTE: This method of cutting height adjustment is applicable only to the fixed-base router supplied with this router table or other Craftsman routers with the following model numbers: 17542 and 17543.

NOTE: A hex wrench 5 inches long and 5mm in diameter is required for this operation (not included).

The cutting height can be adjusted by turning the Fine Adjustment Dial clockwise or counterclockwise with a hex wrench.

NOTE: Be sure the worm gear system in the router is engaged before making adjustments. Test it by turning the Adjustment Dial on the router clockwise and counterclockwise to see if the bit lowers and raises.

If it does not, press in the router Coarse Adjustment Knob and turn the Fine Adjustment Dial until the gears engage.

1. Turn off the table switch by pushing down on the ON/OFF switch.
2. Loosen the clamping lever on the router.
3. Insert the hex wrench into the adjusting hole on the table top (Fig. 17), and turn the router adjustment dial clockwise with the hex wrench to move the router collet down or counterclockwise to move the collet up.
4. When the desired cutting height is set, tighten the clamping lever on the router.

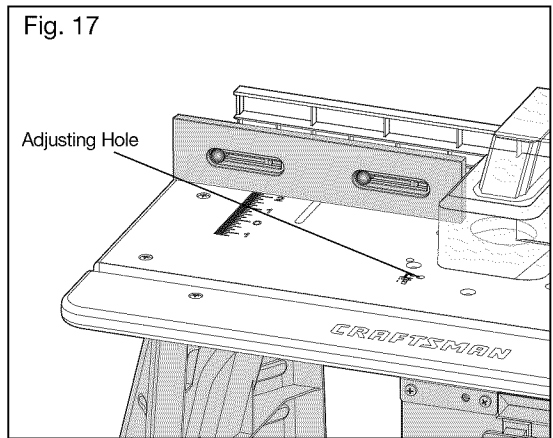
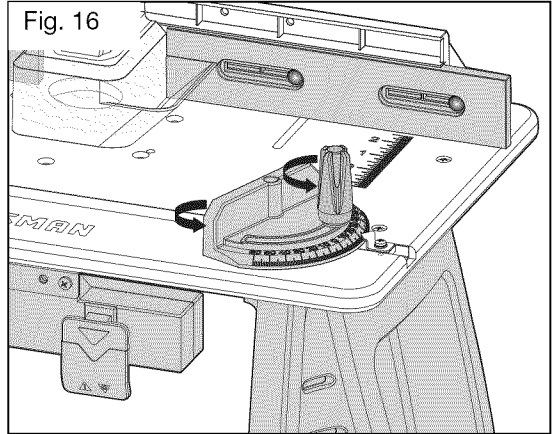

USING THE ROUTER WITH THE ROUTER TABLE

1. Read the and understand entire Product Manual for the router.
2. Always plug the router into the switched outlet in the router table. Never plug a router-table-mounted router into another power source.
3. Make sure the router-table switch is off. Lock-on the router switch.
4. Plug the router-table cord into a power source.
5. Turn on the power to the router table by pulling out the ON/OFF switch.
6. Always control the power to the router with the router-table switch whenever the router is mounted on the table.

ROUTING OPERATION

1. Read the and understand entire Product Manual for the router.
2. Adjust the fence to support the work piece to be cut.

NOTE: The work piece must always be held tight against the fence.

3. Reconfirm that all router adjustments are securely locked before supplying power to the router.
4. Feed the work piece from right to left.

⚠ WARNING: The direction of feed for the work piece is always against the sharp edges of the cutter and into the rotation of the cutter. Failure to follow this rule can result in serious personal injury.

MAINTENANCE

GENERAL MAINTENANCE

⚠ WARNING: Avoid using solvents when cleaning plastic parts. Most plastics are susceptible to damage from various types of commercial solvents and may be damaged by their use. Use clean cloths to remove dirt, dust, oil, grease, etc.

⚠ WARNING: Do not at any time let brake fluids, gasoline, petroleum-based products, penetrating oils, etc., come in contact with plastic parts. Chemicals can damage, weaken or destroy plastic, which may result in serious personal injury.

⚠ WARNING: Always wear safety goggles or safety glasses with side shields during power-tool operation or when blowing dust. If the operation is dusty, also wear a dust mask.

TROUBLE SHOOTING

PROBLEM	CAUSE	SOLUTION
The router does not work	The router is not plugged into the table outlet.	Insert router power cord plug into a table outlet
	The router-table cord is not connected to a power source	Plug the router-table cord into a power source
	The Router switch is in "OFF" position.	Insert key and pull the switch to the ON position
The table surface is not flat	Legs are not properly assembled.	Check assembly directions and securely tighten all fasteners
	Work surface is not flat.	Place router table on a flat, level surface
The router can not be attached to the table	Sub-base is too large	Use a sub-base 6-7/8 in. in diameter or less.

PARTS LIST

Router Table MODEL NUMBER 320.28160

Always mention the Model Number when ordering parts for this tool.

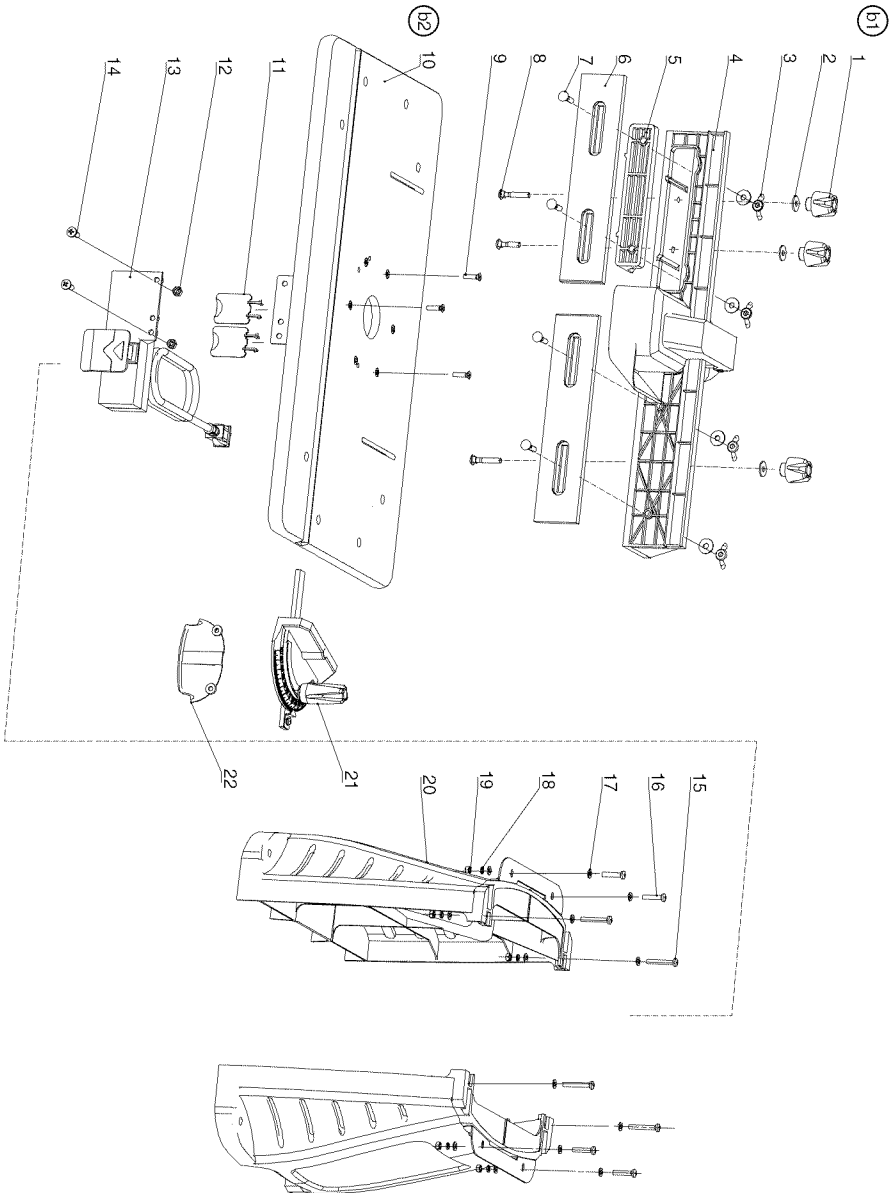

PARTS LIST

Router Table MODEL NUMBER 320.28160

Always mention the Model Number when ordering parts for this tool.

No.	Part No.	Description	Quantity
1	3402187000	Fence Knob	3
2	5650017000	Plain Washer	7
3	5630056000	Wing Nut	4
4	2822298000	Fence Assy	1
5	3123408000	Adjusting Base	1
6	3123237000	Scale board	2
7	5640017000	Square Neck Bolt	5
8	5640168000	Square Neck Bolt	2
9	5620075000	Screw	3
10	2822371000	Main Table Assy	1
11	3123547000	Dust Cover	2
12	5630015000	Prevailing Torque Hexagon Nut	2
13	2822230000	Switch Box Assy	1
14	5620369000	Screw	2
15	5620372000	Screw	4
16	5620052000	Screw	4
17	5650013000	Plain Washer	16
18	5650015000	Spring Washer	8
19	5630003000	Hexagon Nut	8
20	2822372000	Support Assy	2
21	2822231000	Miter Gauge Assy	1
22	3123550000	Dust Cover	1

NOTES

NOTES

NOTES

Get it fixed, at your home or ours!

Your Home

For expert troubleshooting and home solutions advice:

manage my home

www.managemyhome.com

For repair – **in your home** – of **all** major brand appliances, lawn and garden equipment, or heating and cooling systems, **no matter who made it, no matter who sold it!**

For the replacement parts, accessories and owner's manuals that you need to do-it-yourself.

For Sears professional installation of home appliances and items like garage door openers and water heaters.

1-800-4-MY-HOME[®]

(1-800-469-4663)

www.sears.com

Call anytime, day or night

(U.S.A. and Canada)

www.sears.ca

Our Home

For repair of carry-in items like vacuums, lawn equipment, and electronics, call anytime for the location of the nearest **Sears Parts & Repair Service Center**

1-800-488-1222 (U.S.A.)

www.sears.com

1-800-469-4663 (Canada)

www.sears.ca

To purchase a protection agreement on a product serviced by Sears:

1-800-827-6655 (U.S.A.)

1-800-361-6665 (Canada)

Para pedir servicio de reparación a domicilio, y para ordenar piezas:

1-888-SU-HOGAR[®]

(1-888-784-6427)

Au Canada pour service en français:

1-800-LE-FOYER^{MC}

(1-800-533-6937)

www.sears.ca

Sears

© Sears Brands, LLC

[®] Registered Trademark / [™] Trademark / SM Service Mark of Sears Brands, LLC

[®] Marca Registrada / [™] Marca de Fábrica / SM Marca de Servicio de Sears Brands, LLC

^{MC} Marque de commerce / ^{MD} Marque déposée de Sears Brands, LLC