

Baja

Motorsports™

DB30 Mini Bike

Read this manual carefully. It contains important safety information.
No one under the age of 16 should operate this Mini Bike without adult supervision.

OWNER'S MANUAL

Minimum Age Requirement: 16

Weight capacity: 150 lbs.



Rev. I (US)
020509

Always wear a helmet; It could save your Life!

Please obtain, review, and follow provincial / municipal government acts and regulations pertaining to owning and operating an off-road vehicle.



Congratulations on your purchase of the BAJA INC. DB30 Mini Bike.

Your Mini bike is warranted to be free of manufacturing defects in material and workmanship for a period of 90 days from the date of purchase. During the warranty period BAJA, INC. will at its option, repair, provide replacement parts or replace your BAJA INC. DB30 Mini Bike at no charge. This warranty does not cover normal wear items or damage caused by neglect or misuse of the product.

Engine Warranty – 90 days

Frame Warranty – 90 days

Warranty is void if:

Frame is bent or broken due to abuse

Wheels are bent or broken

Fender bent or broken due to abuse

Any sign of impact, accident, jumping, spin-outs or roll over.

BAJA, INC. is not liable for any damage claim or liability claim person or otherwise resulting from the operation of this product in any way.

Should you experience a problem with your vehicle, please call the Baja Inc. customer service line toll free at 1-888-863-2252 between the hours of 7am and 5pm Monday through Friday MST (Mountain Standard Time). MDT (Mountain Daylight Time) during the daylight saving time. You will be instructed how to proceed.

A COPY OF THE SALES RECEIPT IS REQUIRED.



WARNING

This manual should be considered as a permanent part of the vehicle and should remain with the vehicle when resold or otherwise transferred to a new user or operator. The manual contains important safety information and instructions which should be read carefully before operating the vehicle. All operators should obtain, review, and follow provincial and municipal government acts and regulations pertaining to owning and operating an off-road vehicle. Children under the age of 16 should never operate this vehicle without adult supervision.



WARNING

The engine exhaust from this product contains chemicals known to the State of California to cause cancer, birth defects or other reproductive harm.

CALIFORNIA PROPOSITION 65

TABLE OF CONTENTS

SAFETY	2
Safe Operation	3
Safety Gear	5
Location of Labels	6
SPECIFICATIONS	8
LOCATION OF PARTS	9
OPERATION	10
Left and Right Hand Grip	10
Engine ON/ OFF switch and Pull Cord	10
Fuel Fill	11
Fuel Valve	11
INSPECTION BEFORE RIDING	12
ENGINE STARTING AND STOPPING	13
INSPECTION AND MAINTENANCE	14
Checking Oil	14
Changing Oil	15
Check-up of Spark Plug.....	15
Checking and cleaning Air Filter	16
Adjusting Throttle Cable	17
Adjusting Carburetor	17
Adjustment of Rear Brake	18
Adjustment of Chain	19
Clutch cleaning and maintenance	20
Vehicle Washing	21
Instruction for Storage	22
Resumption of Service after Storage	23
MAINTENANCE SCHEDULE	24
TROUBLE SHOOTING	25
ELECTRICAL SCHEMATIC	26
EMISSIONS CONTROL SYSTEM WARRANTY.....	27

SAFETY

Please read this manual and follow all instructions carefully. To emphasize the special information, the symbol  and the words WARNING or CAUTION have some special meanings. Pay great attention to the messages.

WARNING

Indicates a potential hazard that could result in death or injury.

CAUTION

Indicates a potential hazard that could result in vehicle damage.

NOTE: Indicating special information which is to make maintenance easier or instructions clearer.

WARNING and CAUTION are arranged like this:

WARNING-or-CAUTION

The first part will identify a POTENTIAL HAZARD.

The second part will describe WHAT COULD HAPPEN if you ignore the WARNING or CAUTION.

The third part will describe HOW TO AVOID THE HAZARD.

This user's manual contains important safety and maintenance information. Read it carefully before riding. Failing to follow the warnings contained in this manual could result in INJURY or DEATH.

It is important that this manual remain with the vehicle when you transfer it to another user or owner.

All information, illustrations, photographs and specifications contained in this manual are based on the latest product information available at the time of publication. Due to improvements or other changes, there will be some discrepancies in this manual. We reserve the right to make product changes at any time, without notice and without incurring any obligation to make the same or similar changes to the vehicle previously built or sold.

SAFETY

SAFE OPERATION

Rules for Safe Operation

- A pre-operation check must be conducted, before starting the engine, insure safety, prevent mishaps, and damage to components.

ITEM TO CHECK	CONTENT
Steering	Smoothness; No restriction of movement; No play or looseness
Brakes	Proper brake lever free play; enough brake force
Tires	Proper air pressure; Enough tread depth; No cracks, rips, or other damages
Fuel	Enough fuel for the intended trip; Fuel hose connected securely; No damage to fuel tank or cap; Fuel tank cap closed securely
Engine stop switch	Proper operation
Engine oil	Proper level – Check oil by inspecting Engine Oil Dip Stick. The engine oil should be between the Minimum and Maximum lines.
Throttle	Proper free play of throttle lever; smooth response; quick return to idle position
General condition	Bolts and nuts are tight; no rattle from any parts of the engine when running, no visible evidence of Damage

- It is strongly suggested that all operators take a certified motorcycle rider's course prior to operating the vehicle.
- Full attention is required during driving; paying close attention to the following points to avoid any injury to you by other motorized vehicles:
- Do not drive too close to other vehicles.
- Never carry a passenger. This mini bike is for one operator only
- Never operate this mini bike at night. Night is defined as the period of time 30 minutes before sunset to 30 minutes after sunrise.
- Driving at high speeds is the cause of many accidents; do not drive at a speed that the actual situation does not permit.

SAFETY

- **This user's manual contains important safety and maintenance information. Read it carefully before riding. Failing to follow the warnings contained in this manual could result in INJURY or DEATH.**
- **It is important that this manual remain with the vehicle when you transfer it to another user or owner.**
- **All information, illustrations, photographs and specifications contained in this manual are based on the latest product information available at the time of publication. Due to improvements or other changes, there will be some discrepancies in this manual. We reserve the right to make product changes at any time, without notice and without incurring any obligation to make the same or similar changes to the vehicle previously built or sold**
- **Always avoid operating this mini bike on paved surfaces, including; sidewalks, paths, parking lots, driveways, streets, roads, and highways. Never operated this or any Off-Road Vehicle on a public street, road or highway where motor vehicles are in operation.**

SAFETY

SAFETY GEAR

A DOT approved motorcycle helmet is the most important part of your safety gear. A DOT approved motorcycle helmet can help prevent a serious head injury. Choose a helmet that fits snugly. Motorcycle dealers can help in selecting a good quality helmet which fits properly.

WARNING

Operating this Mini Bike without wearing an approved DOT motorcycle helmet, eye protection, and protective clothing could be hazardous.

Operating without an approved DOT motorcycle helmet or eye protection increases your chances of a severe head injury or death in an accident. Operating without protective clothing also increases your chances of severe injury in an accident.

Always wear an approved DOT motorcycle helmet which fits properly. Always wear eye protection (goggles or face shield). You should also wear gloves, boots, long sleeve shirt or jacket, and long pants.

You should wear eye protection when you ride. If a rock or a branch hits your eyes, you could be severely injured. Wear goggles or a face shield.

Wear proper clothing when you ride. The proper clothes can protect you from injury. Wear a good pair of gloves, strong boots that are over the ankle, long pants, and a long sleeve shirt.

CAUTION

Never perform any unauthorized modifications to this vehicle. Only use original replacement parts which can be obtained through BAJA INC. 888-863-2252.

SAFETY

LOCATION OF LABELS

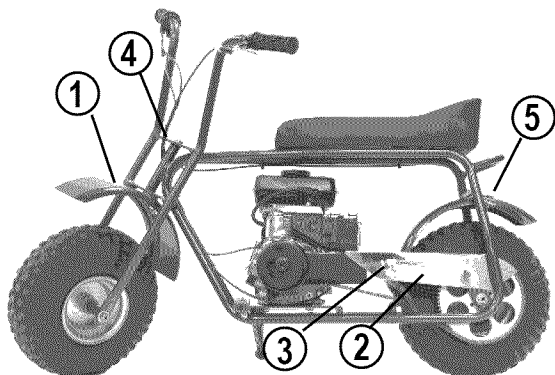

1

WARNING

THIS VEHICLE CAN BE HAZARDOUS TO OPERATE IF DRIVEN CARELESSLY. SERIOUS INJURIES OR DEATH CAN RESULT IF YOU DO NOT FOLLOW THESE INSTRUCTIONS:

- Read and familiarize yourself with owners manual and all labels before operating this vehicle.
- Always wear an approved motorcycle helmet, eye gear and protect the clothing.
- Long hair, loose clothing or items worn by the operator must be covered to prevent them from getting caught in moving parts of the vehicle or surroundings while riding.
- All fenders and guards must be in place at all times while the vehicle is in use or serious injury may occur.
- Hands, feet and loose articles must be kept away from the engine, chain and drive components.
- Check that the throttle and brake controls work freely before starting of engine.
- Before starting the engine, operator must be seated with kickstand up.
- **NO PASSENGERS**
- This vehicle is not made for use on public streets, roads or highways and is not intended to be used in such places.
- Do not speed on this vehicle, the risk of losing control increases if you ride at speeds too fast for specific terrain.
- No person under 16 years of age should operate vehicle without adult supervision.
- Do not jump, pop wheelies or try to perform any other stunts as they can result in serious injury or death.

3

WARNING



- Moving parts can crush and cut.
- Keep hands clear.
- Do not operate with guard removed.

4

IMPORTANT

REGULAR SERVICE PROCEDURES

1. Check oil before starting
2. Adjust chain as necessary
3. Clean clutch assembly every 5 hours as needed
4. Check the pressure
5. Lubricate chain.
6. For further help, refer to trouble shooting chart.

Do not return to retailer. Call 888-863-2252

2

WARNING

TIRE PRESSURES

- Improper tire pressure can cause loss of control resulting in serious injury or death.
- Check pressures on all tires only when tires are cold. 4 psi (27.6 kpa)
- Remove air from tires before demounting.
- Only use replacement tires specified by manufacture.

5

STOP!

DO NOT RETURN THIS ITEM TO THE RETAILER IN THE EVENT THIS UNIT IS DEEMED "DEFECTIVE"; IT CANNOT BE RETURNED TO THE RETAILER CONTAINING ANY GAS OR OIL.

ATTENTION!

CALL 888-863-2252

FOR YOUR LOCAL SERVICE CENTER AND PARTS ASSISTANCE

www.bajamotorsports.net

SAFETY

LOCATION OF LABELS

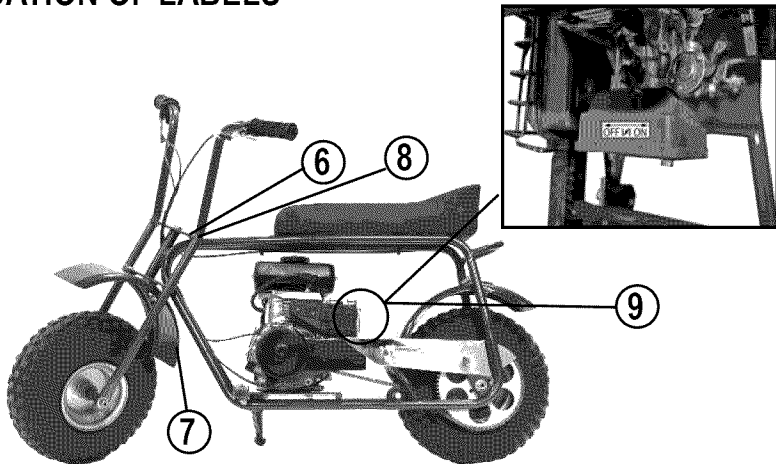

6-  **WARNING**
WEIGHT LIMIT DO NOT
EXCEED 150 LBS.

7-  **WARNING**

Riding on slope
greater than 15 Degrees
increases
the risk of an
accident.



DO NOT

- Return Mini Bike to store
- Attempt wheelies
- Ride on rough rocky terrain
- Attempt stunts
- Attempt steep hills

-Operate without first reading owners manual

DO

- Call Baja 1-888-863-2253
for Service Centers and parts
- Practice safe riding skills
- Always wear a helmet
- Ride on surfaces no greater
than 15 degrees
- Practice safety first

8- **THIS VEHICLE IS AN OFF ROAD VEHICLE
AND IS NOT INTENDED FOR USE ON
PUBLIC ROADS OR HIGHWAYS.**

9- 
OFF ← → ON

SPECIFICATIONS

Description	Data
Overall length	1295mm (51 inches)
Overall width	622mm (24.5 inches)
Overall height	863mm (34 inches)
Wheelbase	927mm (36.5 inches)
Dead weight	35.38 kg (78 lbs.)
Payload	68.04kg (150 lbs.)
Front wheel	145x70-6
Rear wheel	145x70-6
Brake type	Disc
Capacity of gasoline tank	1.4L (0.36 gal)
Capacity of oil tank	0.45L (0.40 qt.)
Starting method	Recoil pull start
Bore a stroke	52mm x 46mm
PTO shaft rotation	Counter clockwise
Horsepower	2.5Hp
Displacement	97.7cc
Max power	1.84KW/3600rpm
Max torque	3.8Nm/2500rpm
Spark plug	Autolite-258, AC-CS49, Champion-CJ14, NGK-BM4A, Denso-W14M-US
Spark plug gap	0.7mm-0.79mm
Ground clearance	102mm (4 inches)
Ignition system	Non contact transistor magneto

LOCATION OF PARTS

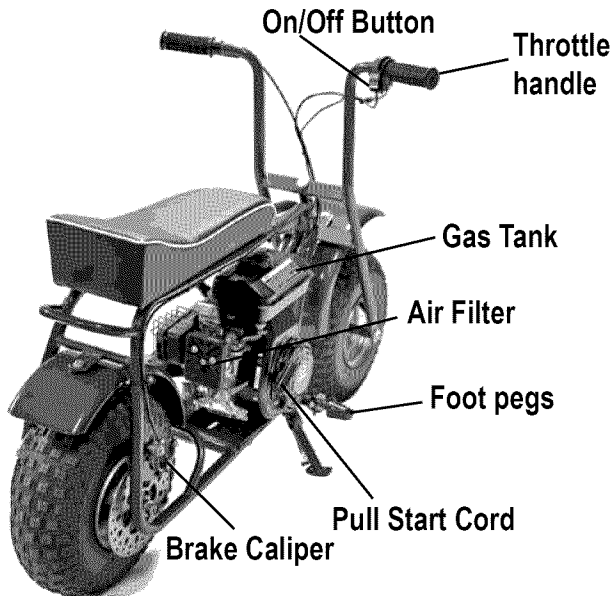
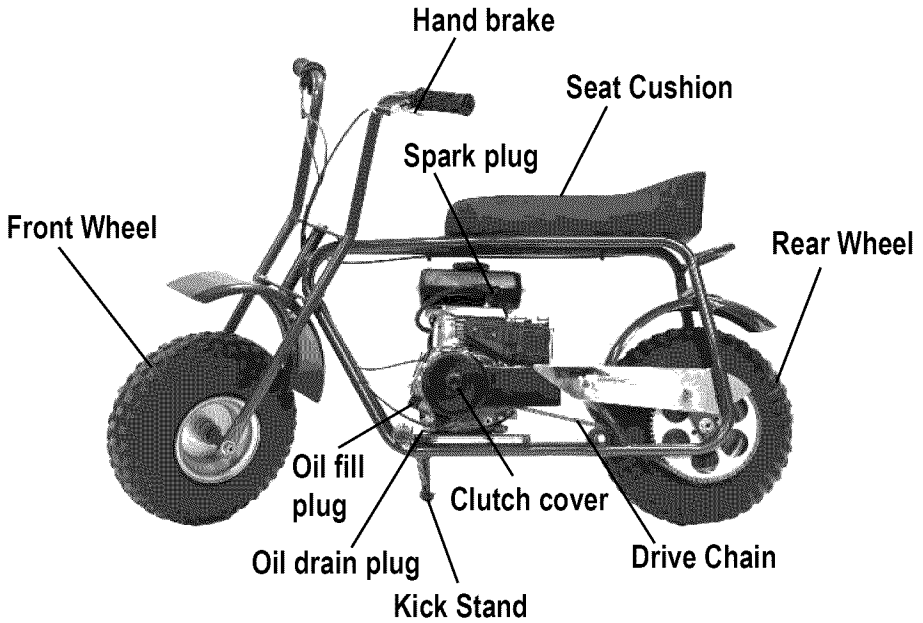

OPERATION

LEFT AND RIGHT HAND GRIP OPERATION

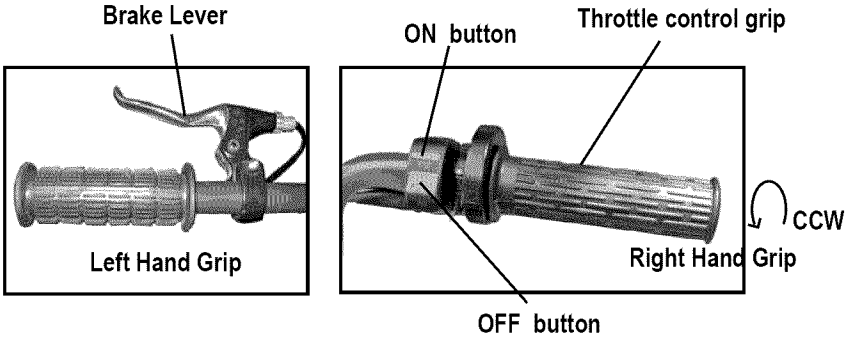

Pulling in brake lever located on left hand grip will stop mini bike.

Applying the hand throttle (moving throttle counter clockwise) will cause engine rpms to increase, causing mini bike to move forward.

When the switch is turned to “” (off) position, the engine will not start. If the engine is running and the Off button is pushed the engine will turn off.

When the switch is turned to “” (on) position, the engine can start by using the manual pull start cord.

ENGINE PULL CORD OPERATION

Pulling the pull cord will start the engine.

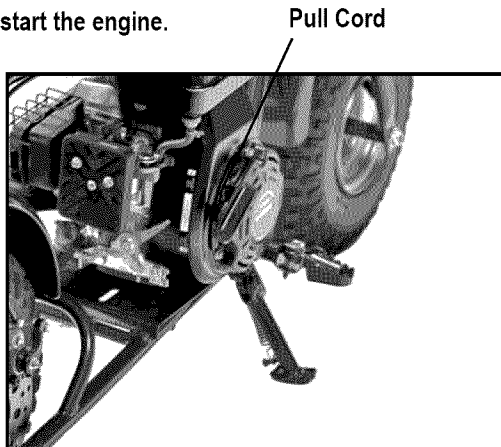

OPERATION

FUEL AND FUEL VALVE OPERATION

Fuel filling

The capacity of the fuel tank is 1.4L (.40 qt.) Unscrew the gas cap by turning it counter clockwise and carefully fill the tank with unleaded gasoline through the opening. **DO NOT MIX GAS AND OIL TOGETHER, THIS IS A 4-STROKE ENGINE.** Replace the gas cap by carefully aligning the threads on the cap and the tank and turning the cap clock wise. Wipe any spilled fuel from the dirt bike using a cloth and dispose of the cloth properly. **DO NOT SMOKE OR REFUEL THE VEHICLE NEAR OPEN FLAMES OR NEAR HEATING UNITS. ONLY REFUEL THE VEHICLE IN OPEN AREAS TO REDUCE THE LIKELIHOOD OF THE BUILD UP OF GASOLINE FUMES.**

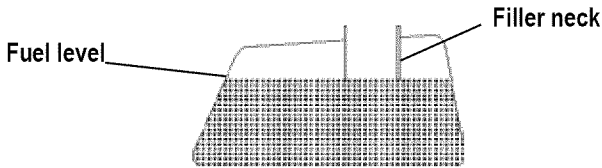

▲ WARNING

Overfilling the fuel tank could be hazardous.

If you overfill the fuel tank, fuel may overflow when it expands. Expanding is due to heat from engine or sun. Overheated fuel could easily catch fire.

Stop adding fuel when the fuel level reaches the bottom of the filler neck.

FUEL VALVE OPERATION

ON: With the handle of the fuel valve to "ON" position, the fuel supply will flow to the carburetor. In this position the engine is able to start and run.

OFF: With the handle of the fuel valve to "OFF" position, the fuel supply is cut off to the carburetor. In this position the mini bike will not start and will not run.

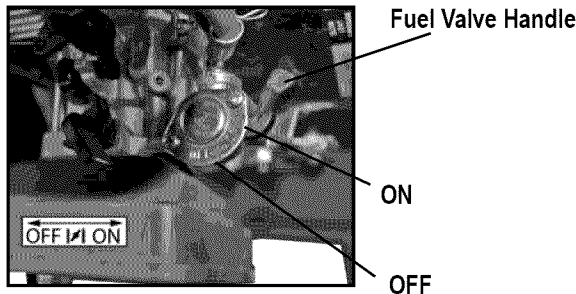

INSPECTION BEFORE RIDING

ITEM TO CHECK	CONTENT
Steering	Smoothness; No restriction of movement; No play or looseness
Brakes	Proper brake lever free play; enough brake force.
Tires	Proper air pressure; Enough tread depth; No cracks, rips, or other damages Note: Check tire pressure, spec is located on side of tire.
Fuel	Enough fuel for the intended trip; Fuel hose connected securely; No damage to fuel tank or cap; Fuel tank cap closed securely
Engine stop switch	Proper operation
Engine oil	Proper level – Check oil by inspecting Engine Oil Dip Stick. The engine oil should be between the Minimum and Maximum lines.
Throttle	Proper free play of throttle lever; smooth response; quick return to idle position
General condition	Bolts and nuts are tight; no rattle from any parts of the engine when running, no visible evidence of Damage

▲ WARNING

Failing to inspect the Mini Bike before operating could be hazardous. Failing to perform proper maintenance could also be hazardous.

Failing to inspect and maintain your Mini Bike could increase the chances of an accident or equipment damage

Always inspect your Mini Bike each time before riding, and make sure it is in a safe operating condition. Refer to the INSPECTION AND MAINTENANCE section in this manual.

▲ WARNING

Operating this Mini Bike with improper tires, or improper tire air pressure could be hazardous.

If you use improper tires or improper air pressure, you may lose control of the Mini Bike. This will cause an accident.

Always use the tires with size and type tires specified in this user's manual. Always maintain proper tire air pressure as described in the INSPECTION AND MAINTENANCE section.

ENGINE STARTING AND STOPPING

⚠ CAUTION

Verify fuel and oil level prior to starting (see pages 11 and 14)
Starting the engine with low or no oil will damage the engine.

⚠ WARNING

Never start the engine in a closed place as the exhausted gas from the vehicle contains toxic carbon monoxide.

1. Ensure there is fuel in fuel tank and oil in crank case.
2. Set fuel valve lever to “ON” position
3. Place choke lever to “ON” position
4. Start engine with pull start cord.
5. Allow engine to idle until engine is warm
6. Place carburetor choke lever toward the “OFF” position when engine has sufficiently warmed up. Note: Engine usually runs best with the choke lever between the on and off positions

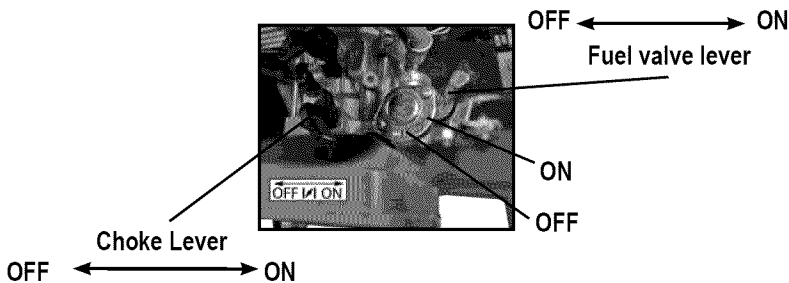

Procedures for stopping engine:

1. Release throttle twist grip to slow down engine.
2. Depress stop button located on right hand grip. Depress button until engine comes to a complete stop
3. Set fuel valve lever (the fuel tank valve) handle to “OFF” position.

⚠ CAUTION

Unnecessarily increasing RPM's to a high level while the Mini Bike is warming up is harmful to the engine.

INSPECTION AND MAINTENANCE

CHECKING THE OIL

Check engine oil each time prior to operating mini bike.

The oil level should be between upper and lower lines of oil gauge.

1. Set the Mini Bike on level ground, screw off the oil gage plug, wipe the oil gage rod clean and then insert the gage plug into the crankcase again to check the oil level. There is no need to screw the oil gage plug completely in the hole to check the oil.
2. Add lubricating oil up to the edge of the fuel plug.
3. Screw oil gage plug tightly.

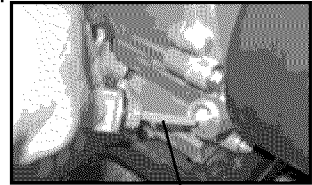

⚠ CAUTION
Never start the engine when there is insufficient lubricating oil. Otherwise, it will cause harm to the engine.

Oil dip stick

Lubricating Oil Recommended

The lubricating oil is an important factor affecting the performance and service life of the engine. Please refer to the chart for the correct grade of engine oil based on the environmental conditions in your area. Do not use any other type of oil other than what is recommended in the chart. **DO NOT MIX OIL WITH THE GASOLINE.**

.45L (.40qt.) Oil

Lubricating oils of different viscosity shall be employed in different regions and at different temperatures.

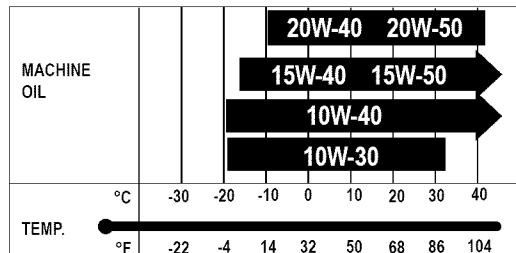

INSPECTION AND MAINTENANCE

CHANGING THE OIL

1. Remove the “Screw Plug” located at the bottom of the engine and let the oil drain into an approved collection container. **DO NOT PERFORM THIS PROCEDURE WHILE THE ENGINE IS HOT. SERIOUS BURNS COULD RESULT FROM CONTACT WITH HOT OIL.**
2. Dispose of the used oil properly. For proper disposal procedures, contact your local oil recycling center.
3. Clean and replace the “Screw Plug” tightly.
4. Refill the engine with the proper amount of oil and recheck the amount of oil in the engine by using the oil gauge plug.

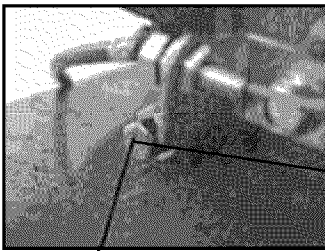

Screw plug for oil draining

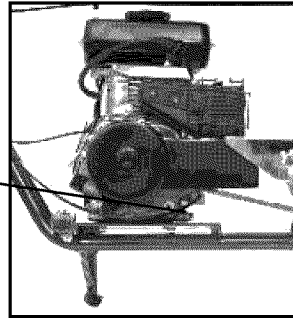

CHECK-UP OF SPARK PLUG

1. Remove the cap of spark plug and screw off the spark plug using the plug wrench.
2. Clean the spark plug all around or replace it if it is corroded or there is too much deposit on it.
3. Regulate the gap of the spark plug to .7mm - .79mm (.028"-.031").
4. The spark plug of the designated type should be used. The applicable type of spark plug:

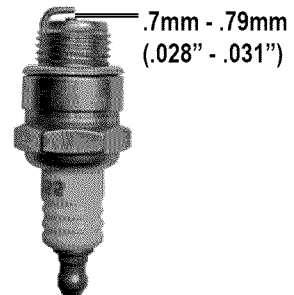

Autolite-258, AC-CS49, Champion-CJ14,
NGK-BM4A, Denso-W14M-US

INSPECTION AND MAINTENANCE

CHECKING & CLEANING THE AIR FILTER

1. Locate Air Filter Box at rear of engine
2. Remove air filter cover by unscrewing phillips head screw
3. Remove foam Air filter element.
4. Tap Air filter element gently to remove most of the dust and dirt.
5. Wash foam element per instructions below then allow to dry thoroughly.
6. Reinstall foam air filter element.
7. Reinstall air filter cover

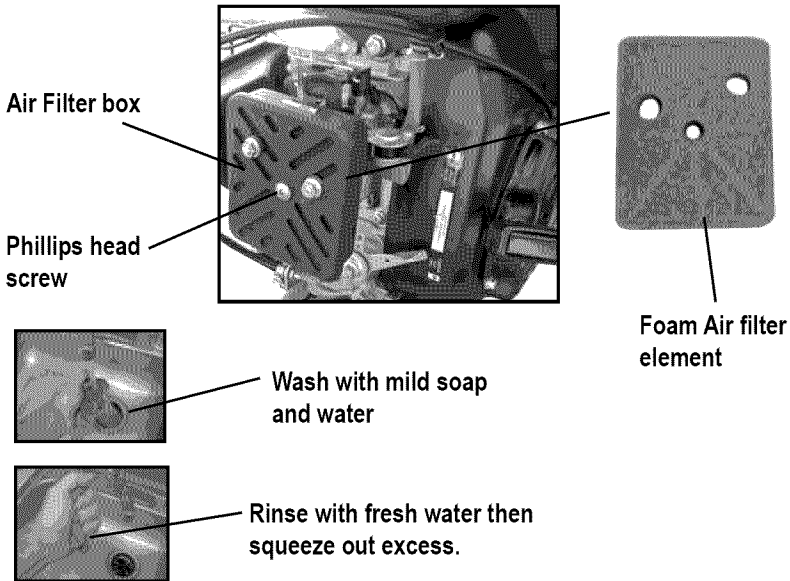

⚠ CAUTION

The air filter element must be intact or the engine will suck in dust and dirt, resulting in a shorter service life of the engine.

Water should be prevented from entering into the filter when washing the vehicle.

The filter element shall be cleaned gently without twisting to prevent it from cracking. Never wash it with gasoline or any acid, alkaline or organic volatile oil to avoid its aging, which will result in reducing the effect of the air filter oil to catch particles before they enter the engine. Replace the filter element with a new one if it is broken or cracked.

INSPECTION AND MAINTENANCE

ADJUSTING THE THROTTLE CABLE

Make sure the throttle cable is adjusted properly. To adjust throttle cable, rotate adjustment nut located at the hand throttle.

Check if the throttle twist grip has the required free operating movement.

The required free operating movement: 2-6mm (.078 -.24in.). If the grip cannot be moved freely, turn the adjusting nut to ensure proper operating movement.

After adjustment, start the engine and check for the operating movement again. Repeat the adjustment if necessary until the desired operating movement is obtained.

Throttle cable adjust nut

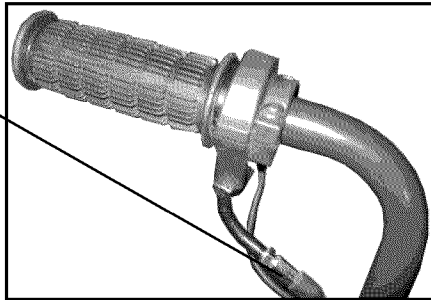

ADJUSTING THE CARBURETOR

Adjusting procedures of idling speed:

1. Support the vehicle by a stand.
2. Adjust the idle speed by the throttle stop screw to 1400 +200 RPM
-150.

⚠ CAUTION

Do not try to correct a malfunctioning carburetor by adjusting the idling speed. If the carburetor is not functioning properly, it should be repaired by a service center.

Adjust idling speed only when the engine is warmed up or 10 minutes after operation.

INSPECTION AND MAINTENANCE

ADJUSTMENT OF REAR BRAKE

1. The front brake hand grip should have free operating movement of 5-7mm (.2-3in.) . Adjust with free play adjustment bolt.
2. To make rear brake pad adjustment, turn rear adjusting bolt clockwise to loosen and counter clockwise to tighten brake tension.
3. Brake pads should be replaced by a qualified service technician once brake shoes are worn .
4. Brakes are adjusted by turning in or out the rear brake adjusting bolt

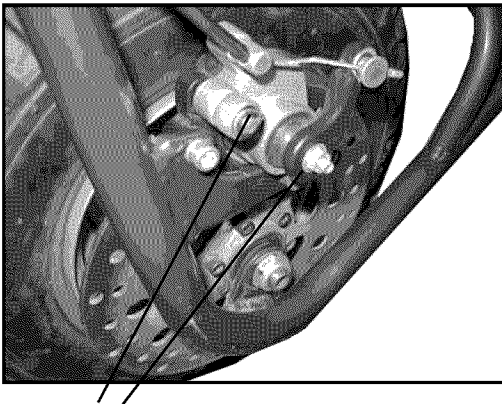
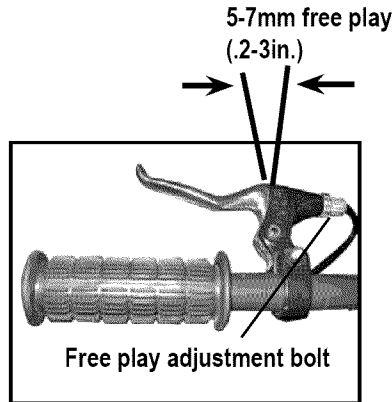

INSPECTION AND MAINTENANCE

ADJUSTMENT OF CHAIN

1. When chain adjustment is needed, loosen 4 bolts under engine.
2. Move engine forward to tighten chain or backward to loosen chain.
3. Tighten bolts under engine Torque bolts to 25 ft./lbs.
4. Repetitively check tension of chain.

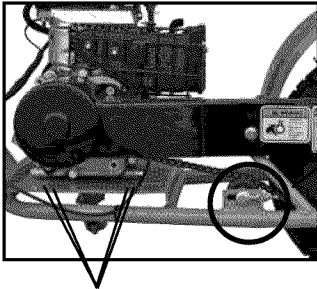

Engine adjusting bolts

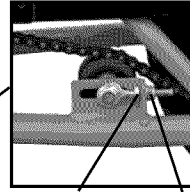

Loosen Chain ← → Tighten Chain

Tighten Chain ← → Loosen Chain

MINOR CHAIN ADJUSTMENT

1. When minor chain adjustment is needed, loosen "Nut 2". Turn "Nut 1" clockwise to tighten chain or counterclockwise to loosen chain.
2. When adjustment is accomplished, tighten Nut 2.

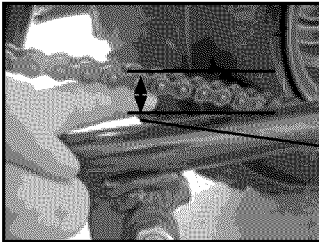

19-25mm
3/4 in. - 1 in.

GREASING PROCEDURES TO THE DRIVING CHAIN

1. Shut off the engine
2. Add light amounts of machine oil or chain grease to the driving chain. (Too much machine oil or chain grease may cause splattering to occur.)

Attention:

The chain should be replaced when the adjusting limit has reached it's maximum.

INSPECTION AND MAINTENANCE

CLUTCH CLEANING AND MAINTENANCE

After every 5 hour of use, your clutch will need cleaning and lubrication. If clutch becomes too dirty or has lack of lubrication, the clutch will have a tendency to stick. This will cause the Mini-Bike to want to take off before throttle is applied.

To clean and lubricate clutch, follow the instructions below:

1. Make sure engine is turned off and engine is cool before removing clutch cover.
2. Remove Clutch Cover
3. With compressed air, blow through holes to remove any dust and/or particles.
4. Oil Clutch bearing with a few drops of 30W motor oil.
NOTE: Make sure oil does not get inside clutch itself.
5. Push mini bike forward without starting allowing oil to flow through bearing surface.
6. Re-install clutch cover.

▲ WARNING

Starting engine with clutch cover removed could be hazardous

Starting engine with clutch cover removed, increases the chance of getting your person caught in moving components which could result in severe injury.

Never start Mini Bike with clutch cover removed.

Blow out clutch with compressed air through large holes

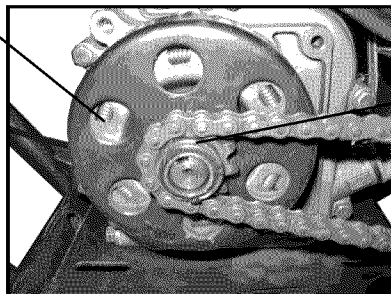
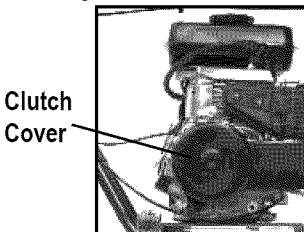

Oil Clutch here ONLY

INSPECTION AND MAINTENANCE

VEHICLE WASHING

Cleaning the vehicle regularly can slow down the color fading of its body and make it easier to check if there is any damage and any oil leakage.

CAUTION

Washing the Mini Bike with over-pressurized water may cause damage to some of its components. Therefore, do use a pressure washer to clean the vehicle. The following parts should be cleaned using low pressure water:

- Wheel hub
- Exhaust pipe
- Fuel tank and lower portion of cushion
- Carburetor
- Head lock and ignition switch
- Meters

1. After pre-wiping, the vehicle should be washed with clean water to remove dirty residues so as to prevent corrosion. Plastic subassemblies should be cleaned by wiping with a cloth or foam soaked in neutral detergent solution, followed by washing with clean water.
2. After the cleaned vehicle is air dried, grease the chain and run the engine at idling speed for a few minutes.
3. Prior to driving, carefully check the braking system repeatedly and repair or adjust it if necessary.

INSPECTION AND MAINTENANCE

INSTRUCTIONS FOR STORAGE

If the vehicle is not going to be used for a long period of time, for example, in winter time, some steps should be taken to prevent malfunction of and damage to its components which might be caused by long storage. Before storing the vehicle for a long period, proper maintenance has to be carried in case maintenance is not completed when the vehicle is put back into use after storage.

1. Change engine oil.
2. Drain off fuel from the fuel tank and carburetor, spray atomized anti-rust oil onto the inside wall of the tank and then close the tank. Dispose of any drained fuel properly so as not to adversely affect the environment.

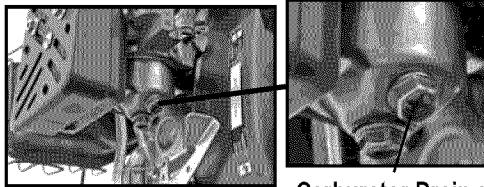

Carburetor Drain screw

Attention:

If the storage will last for more than one month, fuel in the carburetor must be fully drained. This will help ensure that the carburetor maintains its normal performance after the storage.

▲ WARNING

Gasoline is flammable and may cause fire and even an explosion under certain conditions. Therefore, do not smoke, make a fire or have any fire around while draining off fuel.

3. Take out the spark plug, pour about 15-20ml (.5 - .68 oz.) of clean engine oil into the cylinder, step down on the kick lever repetitively several times so as to have machine oil distributed all over the engine and finally fit the spark plug back on.
4. Wash the vehicle clean, wipe it dry and apply an even coat of wax to the painted surface and a coat of anti-rust oil on the chrome-plated surfaces.
5. Inflate the tires as required and put the vehicle up on wooden blocks with the two wheels clearing the ground.
6. Put the vehicle in a shady and cool place free from humidity and direct sunlight and cover it properly (not with plastic or other painted materials). If there is a garage, store it within.

INSPECTION AND MAINTENANCE

RESUMPTION OF SERVICE AFTER STORAGE

1. Remove the covering and remove the wooden blocks used in storing the vehicle. Change the engine oil if the vehicle has been out of service for over 4 months.
2. Drain off the remaining atomized anti-rust oil from the fuel tank, followed by filling it with fresh gasoline therein.
3. Prior to driving, all the required check-ups must be made. It is better to drive it at a low speed in an open area to test its performance before normal operation.

TABLE AND TORQUE OF FASTENERS

Ser. No.	Fastener	Torque (Newton/m) (Foot/lb)
1	Front wheel axle nut	35-45Nm (26-33 ft.lb.)
2	Rear wheel axle nut	35-45Nm (26-33 ft.lb.)

INSPECTION AND MAINTENANCE

Items of Maintenance	Each Use	1st MO/ 20 HR	Every 3 MO/ 50 HR	Every 6 MO/ 100 HR	Every Year/ 300 HR
Engine Oil-Check	X				
*Engine Oil-Change		X		X	
Air Filter-Check	X				
*Air Filter-Clean			X	X	
*Air Filter-Change					X
*Carburetor Sediment cup-Clean			X		
Spark Plug-Check, Adjust				X	
Spark Plug-Replace					X
Idle Speed-Check, Adjust					X
**Valve clearance-Check, Adjust					X
Fuel Tank and Filter- Clean					X
Fuel Tube-Check					X
Centrifugal Clutch-Clean and Lube	X Every 5 hours				
All nuts and bolts-check for tightness	X				
Chain tension-Check	X				
*Brakes-Check	X				
*Throttle-Check	X				
*Throttle cable-Check	X				

“*” means: This item of maintenance should be carried out at a service center. It may be also done by the user with reference to this manual provided special tools and authorized spare parts are used. The user must also be capable of completing the procedure.

“**” means: This item can only be carried out by an authorized service center in order to ensure safety.

TROUBLESHOOTING

Notes:

1. Maintenance should be conducted more frequently when Mini Bike is driven in dusty areas.
2. When Mini bike has exceeded the maximum figures specified in the table, maintenance should be still cycled according to the intervals of time or hours stated herein.

Engine will not Start

1. Fuel Valve OFF	Move Fuel valve lever to ON.
2. Choke OPEN	Move Choke Lever to CLOSED
3. Out of fuel	Refuel
4. Bad fuel; engine stored without treating or draining gasoline, or refueled with bad gasoline	Drain fuel and carburetor. Refuel with fresh gasoline
5. Spark plug faulty, fouled, or improperly gapped	Remove and inspect spark plug. Clean, gap, or replace
6. Spark plug wet with fuel (flooded engine)	Remove and inspect spark plug. Dry and reinstall spark plug.
7. Fuel filter clogged, carburetor malfunction, ignition malfunction, valves stuck, etc.	Take the engine to a qualified mechanic. Replace or repair faulty components as necessary

Engine Lacks Power

1. Filter element(s) clogged	Check air filter clean or replace.
2. Choke lever may be not fully open	Check choke lever
2. Bad fuel; engine stored without treating or draining gasoline, or refueled with bad gasoline.	Drain fuel tank and carburetor. Refuel with fresh gasoline.
3. Fuel filter clogged, carburetor malfunction, ignition malfunction, valves stuck, etc.	Take engine to a qualified mechanic. Replace or repair faulty components as necessary.

ELECTRICAL SCHEMATIC

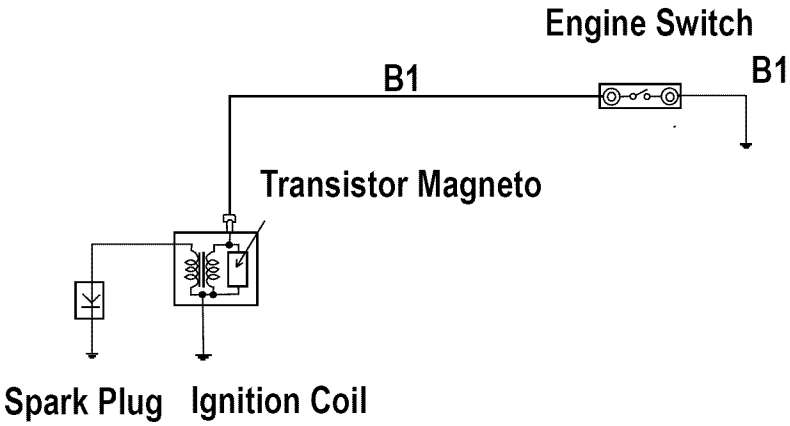

EMISSION CONTROL SYSTEM WARRANTY

BAJA INC. – EMISSION CONTROL SYSTEM WARRANTY

YOUR WARRANTY RIGHTS AND OBLIGATIONS

The emission control system warranty period for this vehicle begins on the date the vehicle is delivered to the first purchaser other than an authorized dealer, or the date it is first used as a demonstrator, lease, or company vehicle, whichever comes first and continues for 60 months after that date, or 5,000km, whichever comes first, provided there has been no abuse, neglect or improper maintenance of your vehicle. Where a warrantable condition exists, the Distributor will repair your vehicle at no cost to you, including diagnosis, parts and labor. If an emission-related part on your vehicle is defective, the part will be repaired or replaced by the Distributor. This is your emission control defects warranty.

OWNER'S WARRANTY RESPONSIBILITIES

As the vehicle owner, you are responsible for the performance of the required maintenance. You should maintain a record of all maintenance performed on your vehicle and retain all receipts covering maintenance on your vehicle. You may not be denied a warranty claim solely because of your failure to ensure the performance of all scheduled maintenance or lack of maintenance records or receipts. You are responsible for presenting your vehicle to an authorized dealer as soon as a problem exists. The warranty repairs should be completed in a reasonable amount of time, not to exceed 30 days.

As the vehicle owner, you should be aware that you may be denied your warranty coverage if your vehicle or a part has failed due to abuse, neglect, improper maintenance, or unapproved modifications.

WARRANTY COVERAGE

The Distributor warrants that each new 2009 and later vehicle:

- is designed, built, and equipped so as to conform at the time of initial retail purchase with all applicable regulations of the United States Environmental Protection Agency, and the California Air Resources Board; and
- is free from defects in material and workmanship which cause such vehicle to fail to conform with applicable regulations of the United States Environmental Protection Agency or the California Air Resources Board for the periods specified above.

EMISSION CONTROL SYSTEM WARRANTY

Your emission control system warranty covers components whose failure would increase an engine's emission, including electronic controls, fuel injection system, carburetor, the ignition system, catalytic converter, or any other system utilized in this vehicle to control emission if it is originally equipped. Also included may be hoses, connectors and other emission-related assemblies. Replacing or repairing other components (including parts, labor, and other costs) not covered by this emission control system warranty or the standard warranty is the responsibility of the owner.

Coverage of repairs under this warranty applies only when repairs are completed at an authorized dealer or repair facility. The Distributor will not cover repairs performed outside of an authorized dealer or repair facility. The use of replacement parts not equivalent to the original parts may impair the effectiveness of your vehicle's emission control system. If such a replacement part is used and an authorized dealer determines it is defective or causes a failure of a warranted part, your claim for repair to bring your vehicle into compliance with applicable standards may be denied.

This Emission Control System Warranty is in addition to the standard Limited Warranty.

EXCLUSIONS AND LIMITATIONS

This warranty does not cover the following:

- Failures or malfunctions of the emission control systems caused by abuse, alteration, accident, misuse, the use of leaded gasoline.
- Replacement of expendable maintenance items unless they are original equipment defective in material or workmanship under normal use, and the first required replacement interval for the item has not been reached. Expendable maintenance items include but not limited to spark plugs, filters, coolant, lubricants, gaskets, hoses, and belts.
- Replacements of parts and other services and adjustments for required maintenance.
- Any vehicle equipped with an odometer or hour meter where the reading is altered so that actual mileage cannot be readily determined.
- Repairs or replacements as a result of:
 - o Accident
 - o Misuse

EMISSION CONTROL SYSTEM WARRANTY

- o Use of replacement parts or accessories not conforming to the original specifications which adversely affect performance
- • Physical damage, corrosion, or defects caused by fire, explosions or similar causes beyond the control of the Distributor.
- • Failures not caused by a defect in material or workmanship.
-
- Use of the vehicle in any type of competitive racing or related events immediately and completely voids this and all other warranties.
-

LIMITED LIABILITY

- The liability of the Distributor under this Emission Control System Warranty is limited solely to the remedying of defects in material workmanship by an authorized dealer at its place of business during customary business hours. This warranty does not cover inconvenience or loss of use of the vehicle or transportation of the vehicle to/from the authorized dealer. The Distributor is not liable to any person for incidental, consequential or special damages of any description, whether arising out of express or implied warranty or any other contract, negligence or other tort or otherwise.
-
- No express emission control system warranty is given by the Distributor except as specifically set forth herein. Any emission control system warranty implied by law, including any warranty of merchantability or fitness for a particular purpose is limited to the express emission control system warranty terms stated in this warranty. The foregoing statements of warranty are exclusive and in lieu of all other remedies. All express warranties not stated in this warranty are disclaimed. Some states do not allow limitations on how long an implied warranty lasts, so the above limitations may not apply if it is inconsistent with the controlling state law.
-
- No dealer is authorized to modify this Emission Control System Warranty. If you have any questions regarding your warranty rights and responsibilities, you should contact BAJA INC. (888) 863-2252.



Baja Motorsports®

Baja, INC.

P.O. Box 61150

Phoenix, AZ 85082

Tel: 602-443-9180

Toll Free: 888-863-BAJA (2252)
