

Bajaj Motorsports®

SC50-2 Scooter Set up Instructions

Removal from Crate

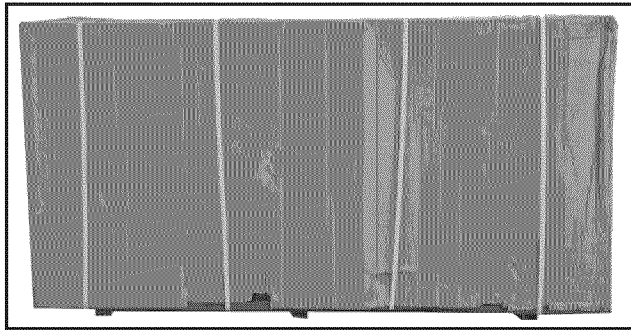

1. Remove cardboard carton from metal frame.

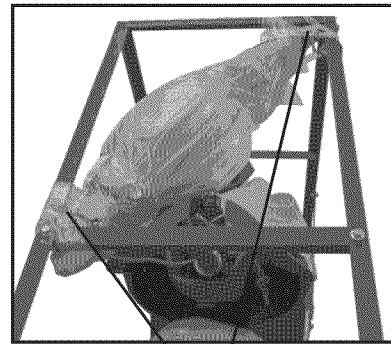

2. Remove wire straps and foam covering from handlebars.

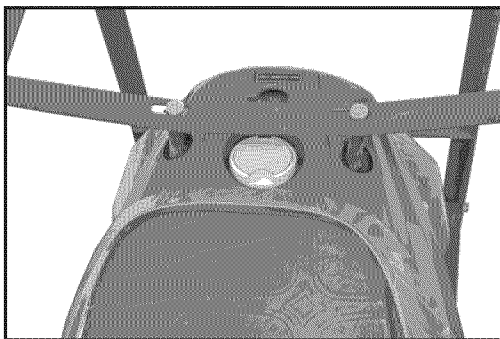

3. Remove bolts holding metal frame to rear of scooter.

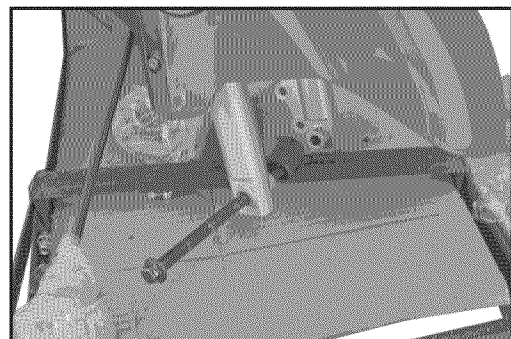

4. Remove axle bolt holding metal frame to front forks.

Removal from crate

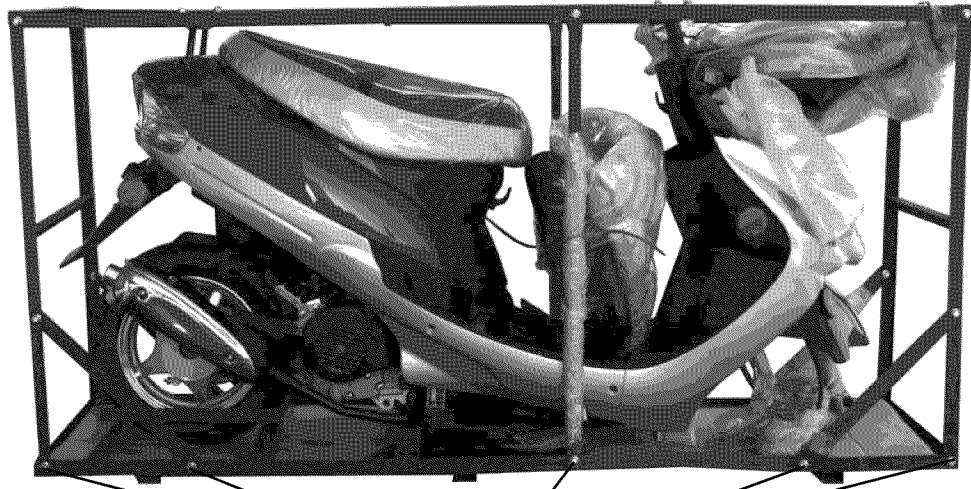

5. Remove metal frame and parts included for assembly.

Parts

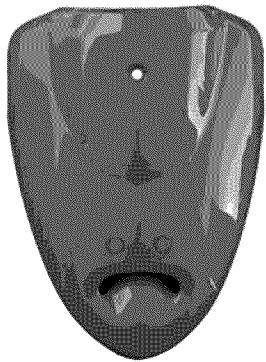

Front fender

QTY 1



QTY 4



Front wheel

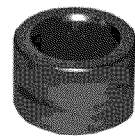

Front wheel spacer
QTY 1

Parts

Parts listed below found under seat



Mirrors

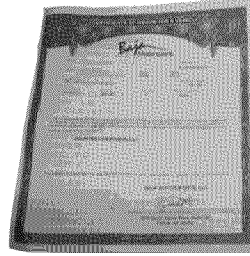

Manufacturer Certificate of Origin



Owners Manual



Floorboard cover/mat



Plastic vin cover



Tool Kit

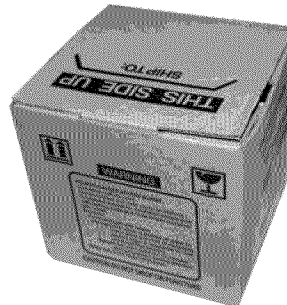

Battery Box

Front wheel

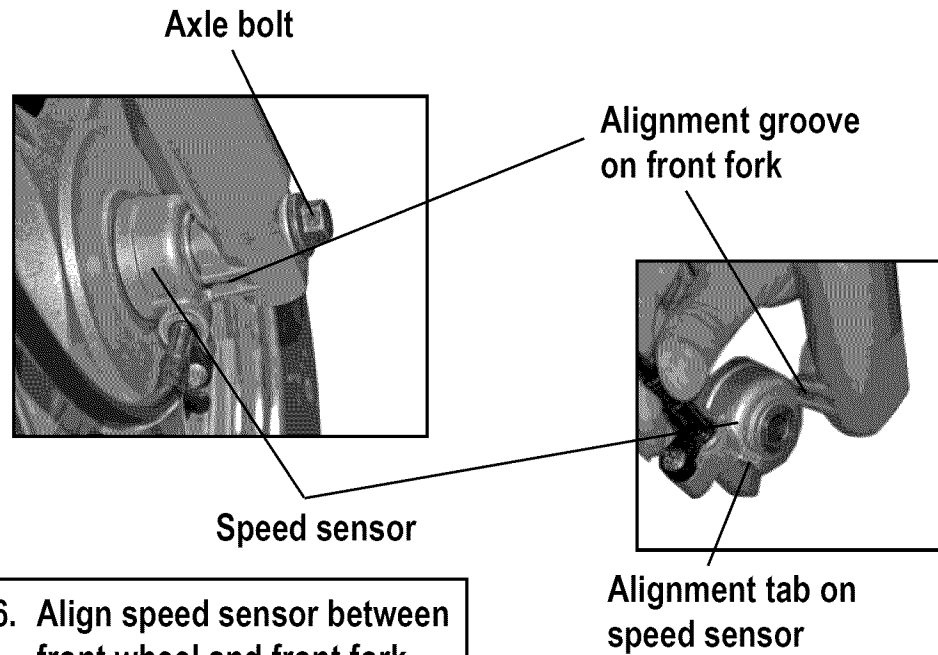

6. Align speed sensor between front wheel and front fork.

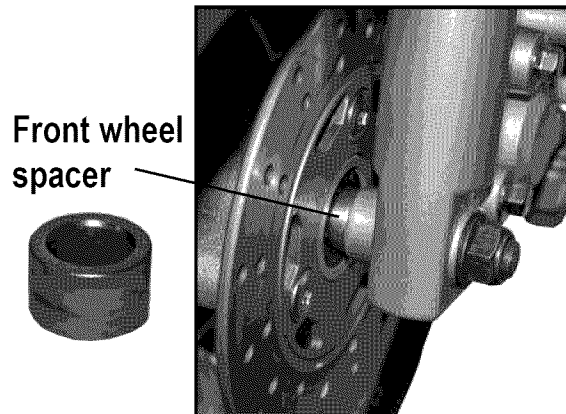

7. Place front wheel spacer between disc brake and fork on axle bolt. Attach front wheel with axle bolt provided. Torque to 33ft.lbs.

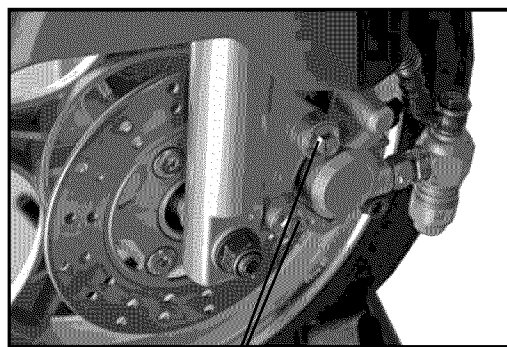
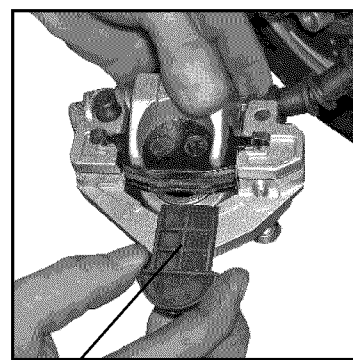

8. Remove brake caliper spacer before attaching brake caliper to front wheel using bolts provided.

Handlebar

Handlebar stem

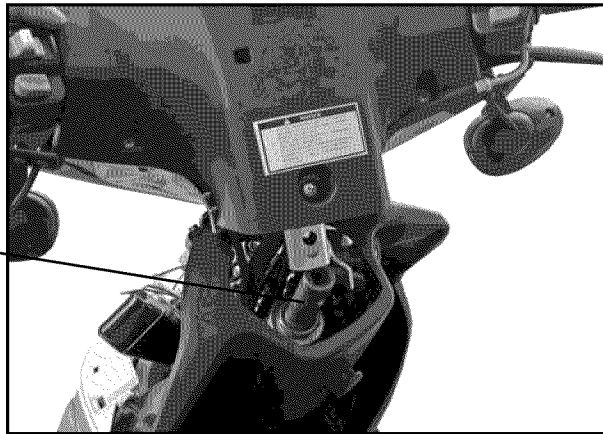

9. Attach handlebar assembly to stem using bolt provided.

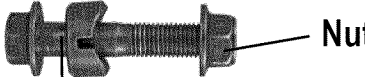

Bolt

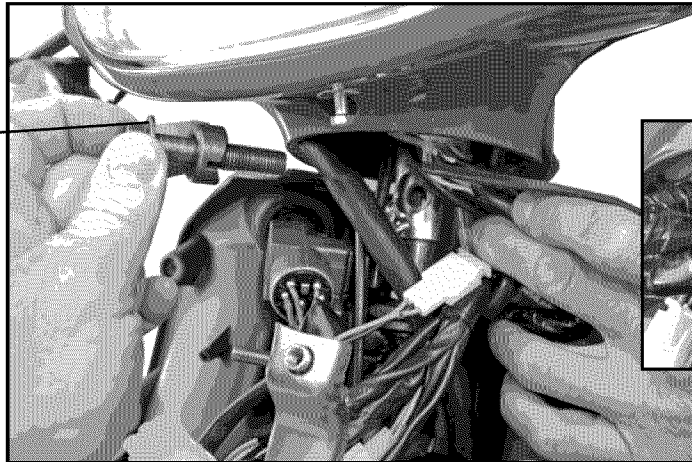

Nut

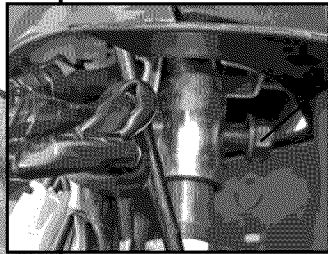

Front fender

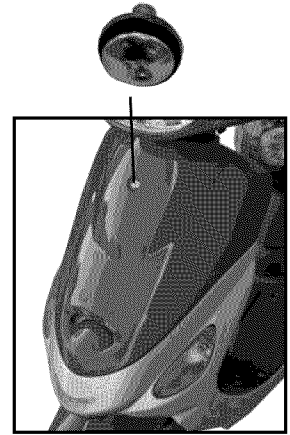
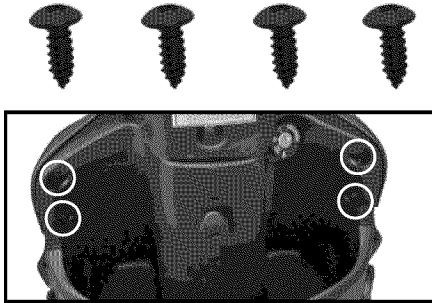
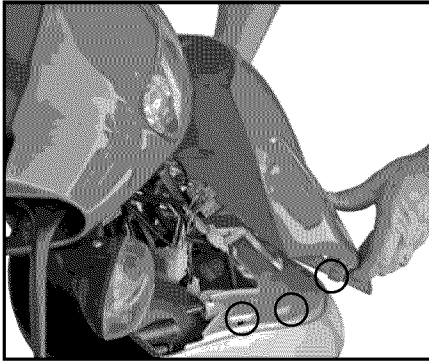

10. Attach front fender. Line up tabs of fender with slots on scooter. Secure with four phillip head screws and one phillip head bolt and washer.

Mirrors



11. Attach left and right mirrors to handlebars.

Battery Installation

Battery located in floorboard under mat.



12. Refer to battery section of owners manual for correct installation and charging of battery.

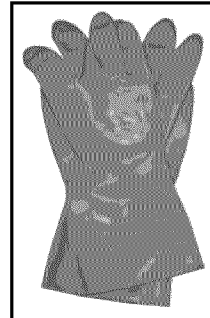
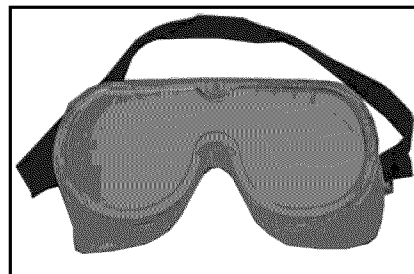
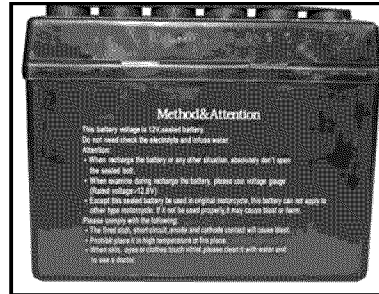
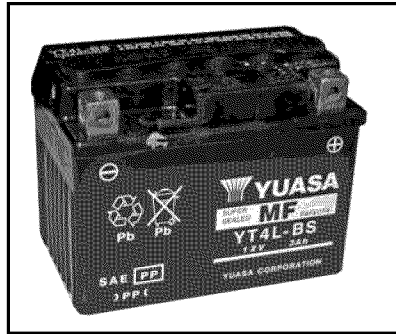

▲ WARNING

The following procedure is very dangerous and should be performed with utmost care and attention. Wear protective eyewear, rubber gloves, and have water available should electrolyte come in contact with skin or eyes. **KEEP ALL CHILDREN AWAY FROM THE AREA WHILE THIS PROCEDURE IS BEING PERFORMED.**

POISON – CAUSES SEVERE BURNS

Contains sulfuric acid.

Avoid contact with skin, eyes, or clothing

To prevent accidents, rinse empty container with water.

ANTIDOTE:

External – flush with water

Internal – Call physician immediately. Drink large quantities of water or milk.

Follow with milk of magnesia, beaten eggs or vegetable.

Eyes – Flush with water for 15 minutes and get prompt medical attention.

KEEP OUT OF REACH OF CHILDREN.

Battery Installation

Note: The following page is for vehicles with battery's containing separate electrolyte pack. Most battery's will come with the electrolyte already sealed into the battery.

Preparing the battery:

- Place battery on level surface. Remove sealing tape from top. (see figure 20)
- Take the electrolyte container out of the plastic bag.
- Place electrolyte container upside down with the sealed silver mouths of the electrolyte bottles in line with the six filler holes of the battery. (see figure 21)
- Push the container down strongly enough to break the silver seals.
- As electrolyte starts flowing into battery, air bubbles will come up from the mouths of the plastic electrolyte bottles.
- Leave bottles upside down in battery holes until electrolyte is completely drained.
- Never leave children unattended around battery.
- If air bubbles cease to float to the top of the electrolyte bottles, tap lightly on top.
- **DO NOT** remove container from battery while it is draining.
- Never cut or pierce electrolyte container.
- After all the electrolyte has drained from the bottles into the battery, pull plastic electrolyte bottles gently out of the battery.
- Discard empty electrolyte bottles in a waste area that is inaccessible to children and animals.
- After filling let battery stand for at least 30 minutes before charging. This allows the electrolyte to penetrate plates for optimum performance and ensures longer battery life.
- After 30 minutes the battery is ready for its initial charge. Place cap strip loosely over the filling holes as shown in the picture. (see figure 22)

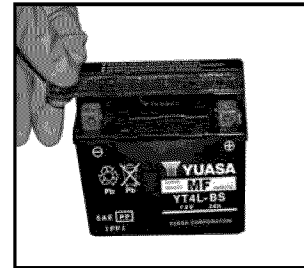

Figure 20

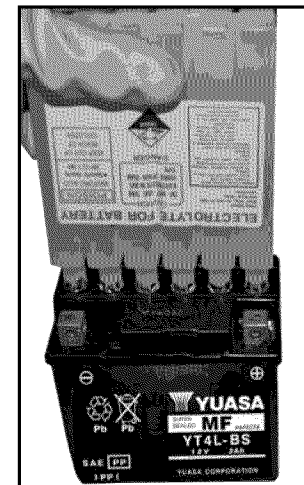

Figure 21

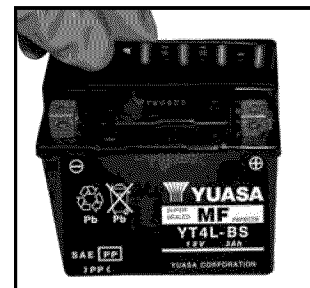

Figure 22

Battery Installation

How to Initially Charge the battery:

1. Connect the red positive (+) cable to the red positive (+) pole of the battery.
(see figure 23)

2. Connect the black negative (-) cable to the black negative (-) pole of the battery. (see figure 24)

Note: The red positive (+) cable has a larger diameter than the black negative (-) cable.

3. Charging rate: Charge battery @ 0.7 Amps for 5 ~ 10 hours.

- After charging is complete, press down firmly with both hands to seat the caps. (Do not pound or hammer.) The battery is now sealed. (see figure 25)
- Locate battery compartment on scooter. The battery compartment is located under the floorboard. (see figure 26)
- Attach red positive (+) cable to positive (+) terminal on battery. Then attach black negative (-) cable to negative (-) terminal on battery.
-

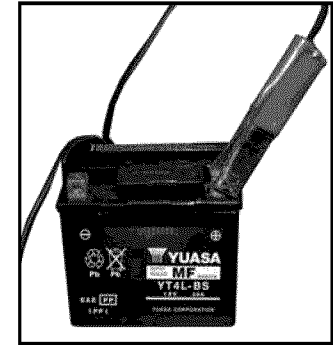

Figure 23

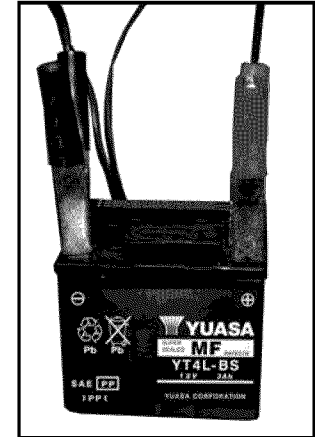

Figure 24

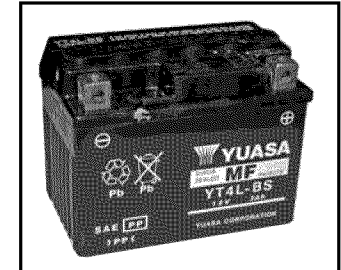

Figure 25

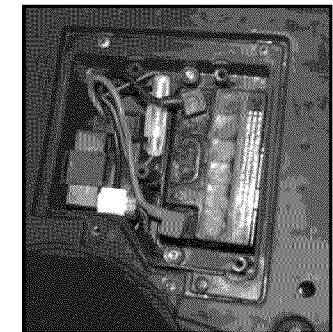

Figure 26

▲ WARNING

NEVER REMOVE THE STRIP OF CAPS
NOR ADD ANY WATER OR ELECTROLYTE.

Gas and Oil

13. Fill engine with correct amount of oil. Refer to owners manual for oil types and quantity.

14. Fill gas tank as specified in owners manual.



Oil Plug.

15. Refer to owners manual for proper starting instructions.
ATTENTION: Side kick stand must be placed in upright position in order to start engine.

!!WARNING!!

This engine may be shipped with packing oil in it. This oil should be drained and replaced with new oil as described in the owners manual. Never attempt to start engine without first replacing the engine oil with the proper amount and grade as described in the owners manual.