

**ASSEMBLY, OPERATING INSTRUCTIONS
AND PARTS LIST FOR**

CRAFTSMAN 1/3 H.P. GRINDER

Split Phase, 115 volts, 60 cycle, 3450 R.P.M.

MODEL NUMBER 397.19580

This is the Model Number of your CRAFTSMAN GRINDER. It will be found on the nameplate attached to the Grinder. Always mention this Model Number when communicating with us regarding your Grinder or when ordering parts.

HOW TO ORDER REPAIR PARTS

All parts listed herein may be ordered through SEARS, ROEBUCK and CO. or SIMPSONS-SEARS LIMITED. When ordering parts by mail from the mail order store which serves the territory in which you live, selling prices will be furnished on request or parts will be shipped at prevailing prices and you will be billed accordingly.

WHEN ORDERING REPAIR PARTS ALWAYS GIVE THE FOLLOWING INFORMATION:

1. The PART NUMBER
2. The PART NAME
3. The MODEL NUMBER 397.19580
4. The NAME of item—1/3 H.P. Grinder

**COAST TO COAST NATION-WIDE
SERVICE FROM SEARS
FOR YOUR CRAFTSMAN GRINDER**



SEARS, ROEBUCK AND CO. and SIMPSONS-SEARS LIMITED in Canada back up your investment with quick, expert mechanical service and genuine CRAFTSMAN replacement parts.

If and when you need repairs or service, call on us to protect your investment in this fine piece of equipment.

SEARS, ROEBUCK AND CO. - U.S.A.
IN CANADA, SIMPSONS - SEARS LIMITED

CRAFTSMAN 1/3 H.P. GRINDER — MODEL NUMBER 397.19580

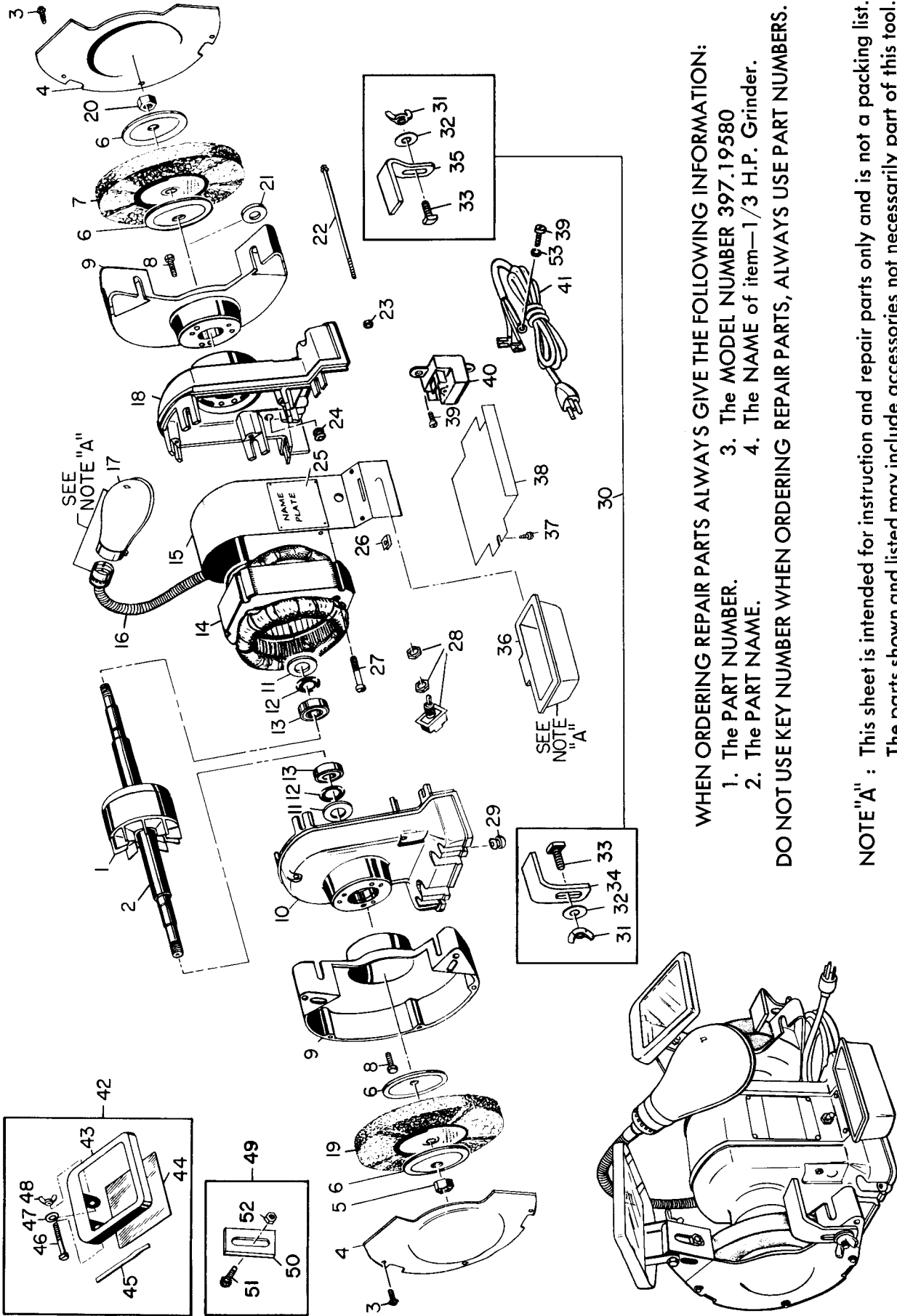

WHEN ORDERING REPAIR PARTS ALWAYS GIVE THE FOLLOWING INFORMATION:

1. The PART NUMBER.
2. The PART NAME.
3. The MODEL NUMBER 397.19580
4. The NAME of item—1/3 H.P. Grinder.

DO NOT USE KEY NUMBER WHEN ORDERING REPAIR PARTS, ALWAYS USE PART NUMBERS.

NOTE "A" : This sheet is intended for instruction and repair parts only and is not a packing list. The parts shown and listed may include accessories not necessarily part of this tool.

PARTS LIST

Key	Part No.	PART NAME	Qty.	Key	Part No.	PART NAME	Qty.
1	3179846	Rotor Assembly	1	39	9417077	* Screw, 8-32 x 3/8 Fill. Head Self Tap	3
2	3160354	Shaft (shrink-fit)	1	40	3181341	Starting Relay	1
3	9415319	†* Screw, 8-32 x 3/8 Hex. Hd. Slotted	6	41	3175512	Cable Assembly	1
4	3160353	† Wheel Cover	2	42	5364929	Eyeshield Pack	2
5	125996	Nut, 1/2-20 Hex. (L. H. Thread)	1	43	5363346	Eyeshield Frame	2
6	5218554	Wheel Flange	4	44	5218630	Eyeshield Glass	2
7	5201092	Grinding Wheel (Fine—60 Grit)	1	45	5218667	Gasket	4
8	9412181	* Screw, 1/4-20 x 7/8 Hex. Hd. Self Tap	6	46	426921	†* Bolt, 1/4-20 x 2 Sq. Head	2
9	3160352	Wheel Guard	2	47	5344307	†* Washer, 1/4 Flat	2
10	3161172	End Frame (L. H.)	1	48	3161433	†* Wing Nut, 1/4-20 Thread	2
11	3167424	Felt Washer	2	49	3176154	Spark Arrestor Pack	1
12	5211995	Ball Bearing Spring	2	50	3175504	† Spark Arrestor	2
13	3161173	Ball Bearing (77503)	2	51	442689	† Screw and L.W., 5/16-18 x 1/2 Pan Head	2
14	3175501	Stator and Coil Assembly	1	52	134556	†* Nut, 5/16-18 Hex.	2
15	3175514	Band	1	53	453299	* Lockwasher, #8	1
16	3178249	Flexible Gooseneck	1		3176153	Instructions and Parts List	
17	3165532	†Lamp Shade (only)	1				
18	3161439	End Frame (R. H.) Cable End	1				
19	5201093	Grinding Wheel (Coarse—36 Grit)	1				
20	120371	* Nut, 1/2-20 Hex.	1				
21	5375637	†* Spacer (Accessory) 1/2 I.D.	4				
22	3168677	Thru Bolt, 10-32 Thread	3				
23	3169218	* Nut, 10-32 Thread	3				
24	3169206	Bushing	1				
25	3175588	Name Plate	1				
26	3161432	Spring Clip	5				
27	3161742	Screw, 8-32 x 1 7/32 Fill. Hd. Self Tap	2				
28	5310072	Toggle Switch	1				
29	5537401	† Base Bushing	4				
30	3161748	Tool Rest Pack	1				
31	142745	†* Wing Nut, 5/16-18	2				
32	120387	†* Washer, 5/16 Flat	2				
33	149535	†* Bolt, 5/16-18 x 3/4 Sq. Head	2				
34	5224450	† Tool Rest (L.H.)	1				
35	5224449	† Tool Rest (R.H.)	1				
36	5336943	† Quench Tray	1				
37	456794	* Screw, 8-15 x 1/2 Hex. Hd. Self Tap	5				
38	3168889	Cover	1				

*Standard Hardware Items—May be purchased locally.

†Items included in package but not assembled.

ACCESSORIES

To extend the range of operations compatible with your grinder, consult your Sears store or catalog for information on the use of the following list of accessories:

1. Alternate Vitrified Wheels . . . General Grinding
2. Expanding Rubber Wheel . . . General Grinding
 - (a) Aluminum Oxide Bands Hard Materials
 - (b) Karbo-Grit Bands Soft Materials
3. Wheel Brushes and Buffers . . . Cleaning & Buffing
 - (a) Wire Heavy Duty
 - (b) Tampico Light Duty
 - (c) Muslin Polishing
4. Resinoid Bonded Cut-off (metal, masonry, wallboard, etc.)
5. Craftflex Cut-off and polishing
6. Flexible Shaft Extension
7. Drill Grinding Fixture

Before discarding packaging material, be certain all parts have been removed.

TO ASSEMBLE: Key numbers refer to illustrations (also to parts list and exploded view).

INSPECT GRINDING WHEELS BEFORE USING. THERE IS ALWAYS A POSSIBILITY OF DAMAGE IN TRANSIT.

1. Attach wheel covers (4) to wheel guards (9) using six screws (3) furnished.
2. Fasten eyeshield (43) to top of wheel guards (9) using bolts— $\frac{1}{4}$ -20 x 2 (46) and wing nuts (48). Always place washer (47) between tab of eyeshield and inner side of wheel guard on both ends of grinder.
3. Attach spark arresters (50) to top front of wheel guards (9) as shown. Note that head of screw with lock-washer attached (51) slides into slot provided. Adjust spark arresters to $\frac{1}{16}$ from wheel and tighten nuts (52).

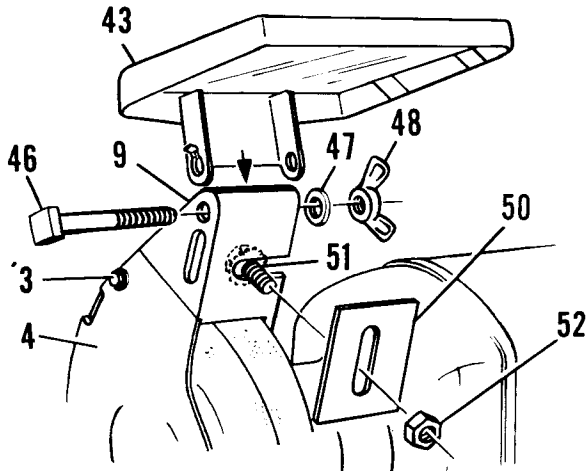

ILLUSTRATION FOR STEPS 1, 2, AND 3

4. Attach tool rests (34 & 35) to bottom front of wheel guards (9) inserting bolts— $\frac{5}{16}$ -18 x $\frac{3}{4}$ (33) from inner side of guards as shown. Add washers (32) and wing nuts (31).
5. Insert 4 base bushings (29) in slots provided at each corner of base as shown in illustration. *Thick section of bushing extends below grinder base.*

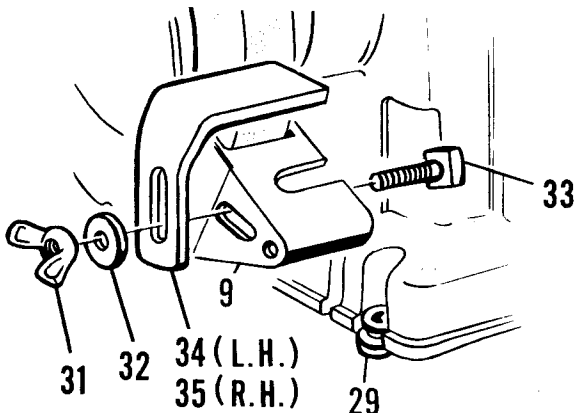

ILLUSTRATION FOR STEPS 4 AND 5

6. Attach lamp shade (17) to bulb socket and tighten screw and nut attached. Either 40 watt "regular" or 50 watt "rough service" bulbs are recommended in your grinder lamp.
7. If quench tray (36) is obtained, mount to front of cover band (15) in knockout slot provided. Lip at side of tray hooks into slot.
8. The illustration below shows how the washer spacers (21) are attached to your grinder when accessories are used that do not require removal of inner guards (9).

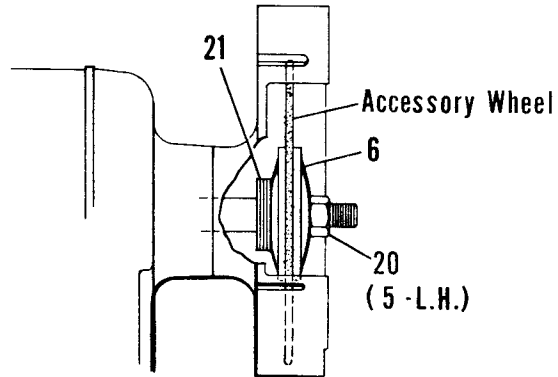

ILLUSTRATION FOR STEP 8

9. Inner guards (9) may be removed for use of some accessories (as listed on page 3) to give greater freedom of movement to the operator for buffing and polishing operations. The drawing below illustrates this operation:

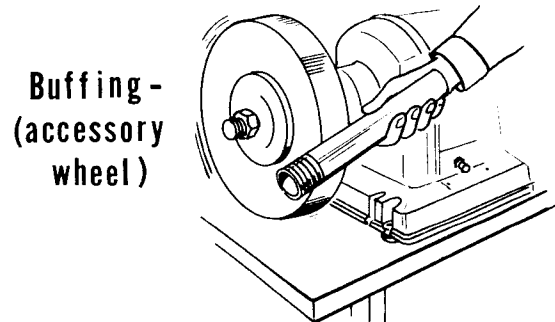

ILLUSTRATION FOR STEP 9

TO INSTALL: Grinder must be mounted on horizontal surface.

The Craftsman grinder pedestal is designed especially for your grinder. Use of the pedestal will permit greater accessibility to your unit for grinding, buffing, and many other uses.

To mount your grinder to the pedestal, align slots in base with corresponding holes in table of the pedestal. Use two $\frac{3}{8}$ " x 2" bolts (with flat washers beneath the heads) to secure the grinder. Tighten nuts until space between grinder base and pedestal is $\frac{3}{16}$ " as shown in drawing:

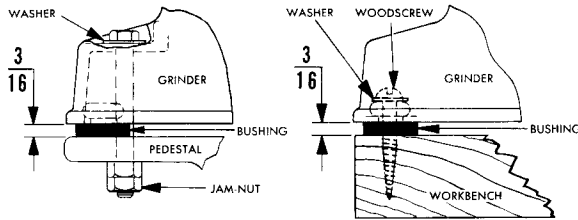

ILLUSTRATION FOR MOUNTING GRINDER

Using a second nut on each bolt, jam-tighten against the first to prevent loosening by vibration.

A Craftsman workbench provides a good mounting for your grinder, when drawer space is desired as well as surface space.

Mount unit to bench top using two wood screws through base grommets at front of grinder only. Use two $\frac{1}{4}$ " x $1\frac{1}{2}$ " round-head screws. Tighten screws until clearance between base and surface of bench is $\frac{3}{16}$ " (see illustration above).

TO OPERATE:

BE SAFE! USE EYESHIELDS FURNISHED WITH GRINDER AND WEAR RECOGNIZED EYE PROTECTION. STAND AWAY FROM FRONT OF GRINDER DURING FIRST MINUTE OF OPERATION.

Before starting grinder, follow instructions in the next two paragraphs concerning grounding, providing proper fuses and wire chart for electrical extension wire sizes.

This grinder is equipped with a 3-conductor cord having a fixed grounding conductor. Receptacle not having provision for the grounding pin will require a plug adapter as shown in illustration below. Protection of the operator may be insured by ALWAYS CONNECTING THE GROUND WIRE TO A PERMANENT GROUND BEFORE PLUGGING IN THE POWER LEADS. This connection can be made to the receptacle cover screw, if the outlet box is properly grounded, or to another suitable ground such as a water pipe.

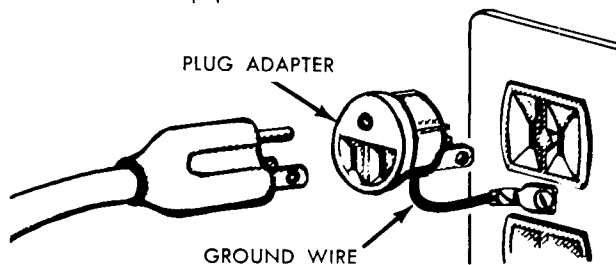

BE SURE BOX IS GROUNDED

If this grinder is not required to start under load and is not overloaded after starting, the standard

15 ampere lighting circuit fuses should be satisfactory. Otherwise, a "delayed-action" type fuse designed to meet the demands of motor protection and minimize possible nuisance of "blown" fuses from momentary overloading.

The following wire sizes are recommended for extensions or special circuits.

Length of Two-Conductor Extension	Wire Size Required (American Wire Gauge No.)
15 feet or less	No. 14
50 feet or less	No. 12
100 feet or less	No. 10

1. To start, move the toggle switch to "ON" position. (Note: The lamp is also controlled by this circuit.) If grinder does not start immediately, disconnect power and check for lack of current at power source. If, after verification of sufficient power at source, the grinder will not start, return it to point of purchase for inspection.

2. The tool rests should be positioned securely to support the material to be ground so that it makes contact with the wheel slightly above center-line of shaft at the desired angle.

3. Begin grinding by moving workpiece into contact with the wheel gradually. Move from side to side across the wheel evenly to remove material more smoothly and help retain the squareness of the wheel surface.

DO NOT FORCE WORK AGAINST GRINDING WHEELS! EXCESSIVE PRESSURE MAY CAUSE DAMAGE OR BREAKAGE.

Grinder should run near full speed for effective grinding and buffing.

TO MAINTAIN:

1. When vitrified wheels become irregular or glazed from use they may be trued and cleaned, returning them to near-new condition with the cutting face fresh and square. Use a Sears wheel dresser to keep your wheels in good condition.

2. Clean out any accumulation of cuttings and abrasive each time outer cover is removed.

Note: Wheel guards (Key No. 9) may be removed for some adaptations of accessory wheels without voiding the guarantee, however, disassembly of electrical connections or end frames (10 & 18) by anyone other than an authorized electric motor repair station will void the guarantee.

3. Lubrication was provided at the factory for the life of the ball bearings.

GUARANTEE

We will repair, at no cost, grinders that show defects in materials or workmanship, if returned within one year from the date of purchase.

SEARS, ROEBUCK AND CO.