

**OPERATING INSTRUCTIONS
AND PARTS LIST FOR
CRAFTSMAN 3/4 H. P.
CAPACITOR START TYPE MOTOR
115 Volts, 60 Cycles, 3450 R.P.M.**

MODEL NUMBER 113.12260

This is the Model Number of Your Craftsman Motor. It will be found on the nameplate attached to the motor. Always mention the Model Number when communicating with us regarding your motor or when ordering parts.

HOW TO ORDER REPAIR PARTS

All parts listed herein may be ordered through SEARS, ROEBUCK AND CO. or SIMPSONS-SEARS LIMITED. When ordering parts by mail from the mail order house which serves the territory in which you live, selling prices will be furnished on request or parts will be shipped at prevailing prices and you will be billed accordingly.

WHEN ORDERING REPAIR PARTS, ALWAYS GIVE THE FOLLOWING INFORMATION AS SHOWN IN THIS LIST:

1. The PART NUMBER.
2. The PART NAME.
3. The MODEL NUMBER—113.12260.
4. The NAME of Item—3/4 H. P. Motor.

**COAST TO COAST NATION-WIDE
SERVICE FROM SEARS
FOR YOUR CRAFTSMAN MOTOR**



SEARS, ROEBUCK AND CO. and SIMPSONS-SEARS LIMITED in Canada back up your investment with quick, expert mechanical service and genuine CRAFTSMAN replacement parts.

If and when you need repairs or service, call on us to protect your investment in this fine piece of equipment.

**SEARS, ROEBUCK AND CO.—U. S. A.
IN CANADA, SIMPSONS - SEARS LIMITED**

**PARTS LIST FOR CRAFTSMAN 3/4 H. P. CAPACITOR START TYPE
ELECTRIC MOTOR—MODEL NUMBER 113.12260**

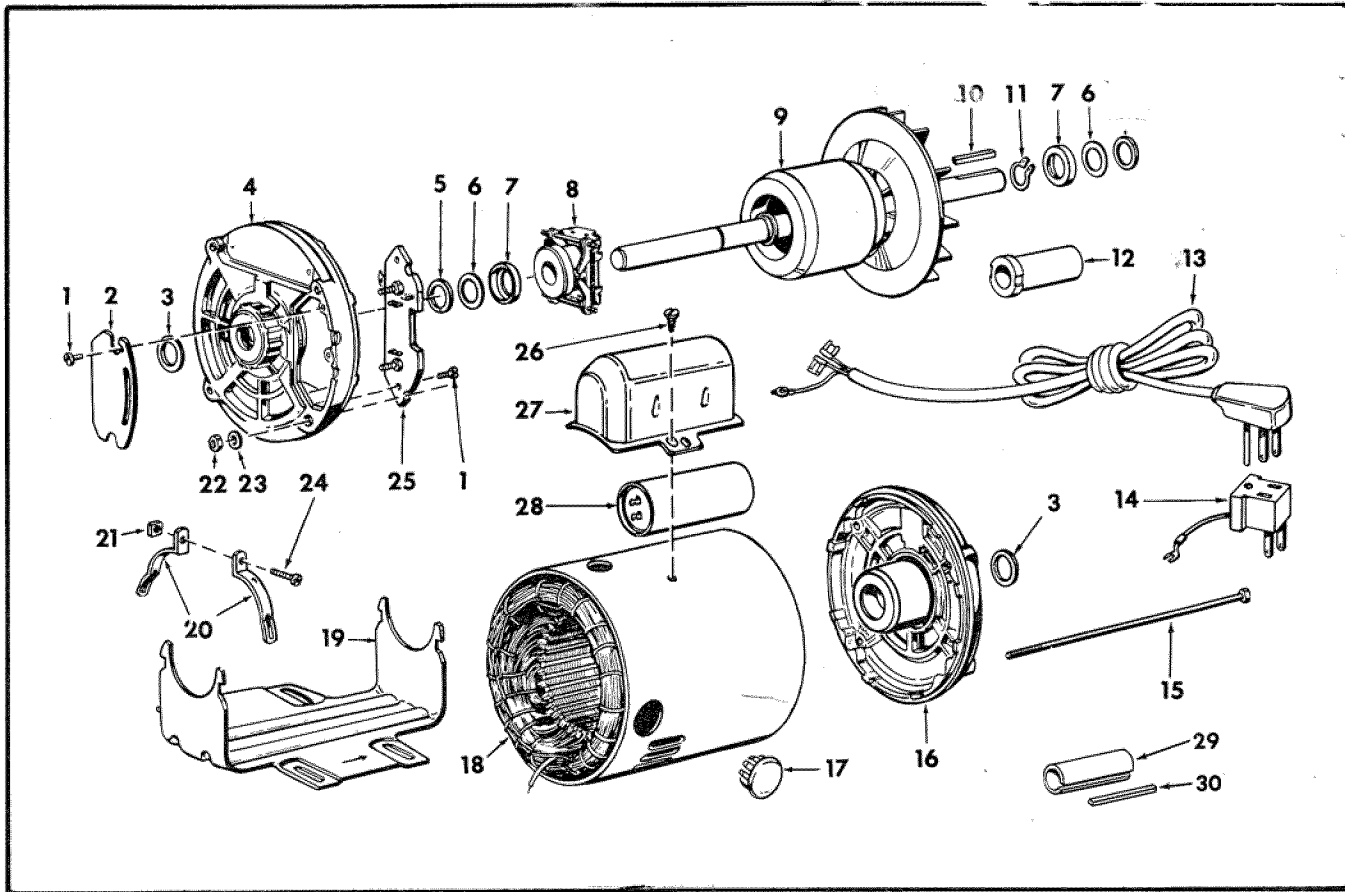

WHEN ORDERING REPAIR PARTS, ALWAYS GIVE THE FOLLOWING INFORMATION AS SHOWN IN THIS LIST:

- | | |
|--------------------|---------------------------------------|
| 1. THE PART NUMBER | 3. THE MODEL NUMBER — 113.12260 |
| 2. THE PART NAME | 4. THE NAME OF ITEM — 3/4 H. P. MOTOR |

Always Order by Part Number — not by Key Number

Key No.	Part No.	Description	No. Key	No. Part	Description
1	448011	*Screw, No. 8-32 x 3/8, Type 23, Pan Hd., Slotted, Cad. Pl., Steel	18	64028	Stator Assembly
2	37576	Cover, Terminal	19	37585	Base
3	30779	Washer, Oil Sling (Rubber)	20	37180	Clamp, Base
4	37593	Shield Assembly, End (Terminal Plate End)	21	120611	*Nut, Sq., No. 10-32 x 3/8 x 1/8, Cad. Pl., Steel
5	30766	Washer, End Play (Plastic)	22	120614	*Nut, Hex., No. 10-32 x 3/8 x 1/8, Cad. Pl., Steel
6	30768	Washer, Thrust	23	9417373	*Washer, No. .203 x 7/16 x 1/32
7	37021	Retainer, Trust Washer	24	132128	*Screw, Mach., No. 10-32 x 7/8, Fil. Hd. Slotted, Cad. Pl., Steel
8	37579	Actuator Assembly, Centrifugal	25	37594	Switch Assembly, Starter
9	64027	Rotor Assembly	26	169752	*Screw, No. 10-32 x 1/4, Type C, Pan Hd., Slotted, Cad. Pl., Steel
10	23428	Key, Shaft	27	37587	Cover, Capacitor
11	30783	Ring, Retaining	28	37588	Capacitor
12	37574	Guard, Shaft	29	30790	Bushing (to Adapt Shaft from 1/2" to 5/8" Dia. with Shaft Key)
13	37567	Cord and Plug	30	30789	Key, Shaft
14	37568	Plug, Adaptor	Not Shown	64029	Operating Instructions and Parts List for Craftsman 3/4 H. P. Motor Model 113.12260
15	37582	Stud, Stator			
16	37597	Shield Assembly, End (End Opposite Terminal Cover)			
17	37189	Plug, Conduit			

*Standard Hardware Items — May be Purchased Locally.

MOUNTING, CONNECTION AND MAINTENANCE INSTRUCTIONS FOR CRAFTSMAN MOTOR—MODEL No. 113.12260

This Craftsman Motor is of the capacitor-start type designed for use on a single-phase, 60-cycle, alternating-current supply of 115 volts, with a simple means of reversing the direction of rotation provided. The motor may be operated in any position.

MOUNTING THE MOTOR

1. This motor was given a thorough electrical and mechanical inspection before it was shipped from the factory. In order to make sure that no damage has occurred during shipment, the following check procedure should be made before mounting the motor in the particular application for which it was purchased.
 - a. Rotate the shaft with the fingers to make sure it turns freely and smoothly.
 - b. Clamp motor base to work bench or table and remove key from shaft. Connect motor to the proper voltage supply temporarily in accordance with instructions under "Connecting the Motor". When energized, the motor should operate with only a small amount of electrical "hum" and very low bearing noise.
 - c. Notice direction of shaft rotation to make sure it is correct for the equipment to be driven. If direction of rotation is not correct, reverse rotation as outlined in instructions listed under "Connecting the Motor". Re-install the key in motor shaft.
2. Disconnect the motor from temporary power source and mount it in the application for which it was purchased.
3. The motor should be installed in a location as cool and dry as possible and should be protected against excessive deposits of dust and dirt. (See figure 1 for mounting dimensions.) The motor must not be confined in a small space that will restrict the flow of cooling air over internal electrical windings.
4. Before tightening the motor mounting bolts, make sure all four mounting points of the base are in contact with the surface to which the motor is being attached. If the motor base does not contact the mounting surface properly, the base (or support) may be warped or cracked when mounting bolts are tightened.
5. Make sure all pulleys are tightened securely on their shafts and correctly aligned. Proper pulley alignment may be obtained by holding a straight edge across the flat sides of the pulleys and adjusting to it. (See figure 2.)
6. Adjust the belt tension so that pressure of fingers on the belt will deflect it readily as shown in figure 3. Excessive belt tension increases the load on the motor and de-

creases bearing life. Loose belts reduce operating efficiency and shorten belt life.

7. After the motor base has been properly adjusted to the mounting bracket, tighten all motor mounting bolts securely.

NOTE: In order to prevent accumulation of static electric charges due to belt friction, the motor frame or base should be grounded to a water or steam pipe. A metallic connection should also be provided between the motor and the device being driven.

8. Included with this motor is a new molded shaft guard that can be easily twisted into place over the unused shaft extension as an extra safety feature.

CONNECTING THE MOTOR

CAUTION: This motor will be damaged if connected to a current source other than 60-cycle alternating-current (ac).

1. The motor must be operated on 115-volt, 60-cycle a-c power when connected as outlined in instructions that follow. Motor wires are color coded to make connections easy to accomplish.
2. A 48-inch, 3-conductor (center ground wire) cord and plug assembly is attached at the factory, with the two power leads connected to the quick connect tabs adjacent to terminal posts "T₁" and "T₄". (See figure 4.) In event this cord is removed and the motor wired for a permanent installation, connect one power lead to terminal "T₁" (or quick connect tab adjacent to it). Connect the other power lead to terminal "T₄" (or quick connect tab adjacent to it).
3. Connections between motor and power source should be made through a switch and fuse block. Use a 20-ampere fuse for 115-volts. Fuses of the delayed-action type, such as "Fustat" or "Fusetron" are recommended, as they are designed for best motor protection.
4. The wire sizes listed below are recommended for circuit connections between motor and power supply, or extension cords (if used).

Length of Three-Conductor Extension	Wire Size Required (American Wire Gauge No.)
100 feet or less	No. 12
100 feet to 150 feet	No. 10
150 feet to 200 feet	No. 8
200 feet to 400 feet	No. 6

NOTE: For circuits of greater length, the wire size must be increased proportionally.

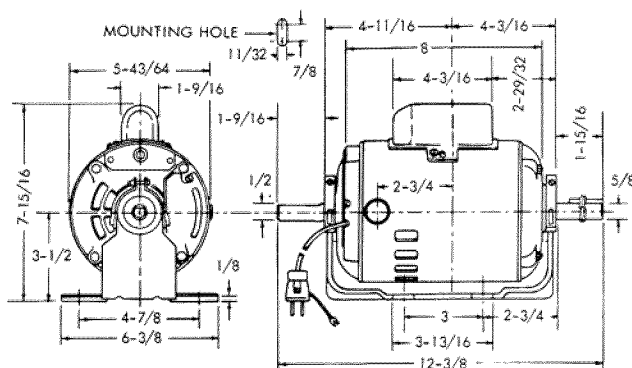

Figure 1

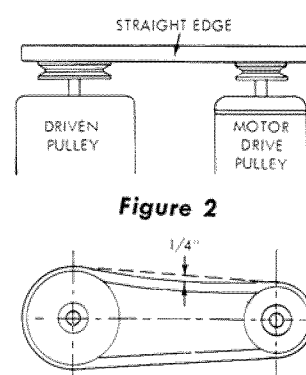

Figure 2

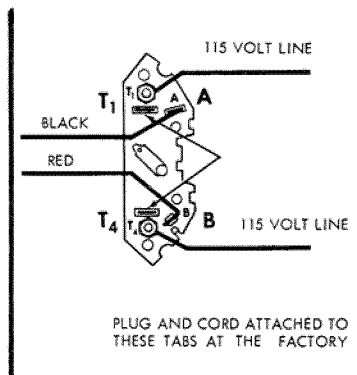

Figure 4

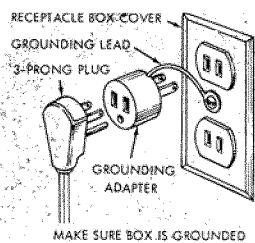

Figure 5

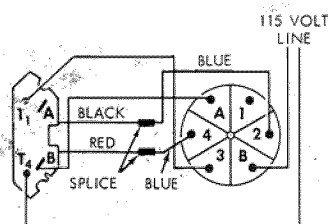

Figure 6

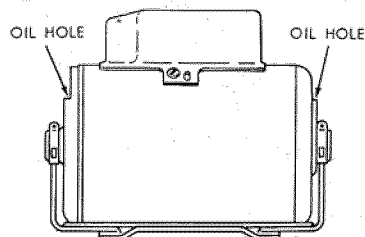

Figure 7

5. The Black and Red motor leads are connected to the quick connect tabs on terminal board. (See figure 4.)

NOTE: To reverse direction of rotation, interchange position of Black and Red motor leads.

WARNING: Do not change any of these connections with current on.

6. This motor is equipped with a 3-prong connector plug (Underwriters' Laboratory approved) as a safety measure. The longest of the three prongs is connected to the motor housing through the power cord. When the plug is inserted into a properly grounded receptacle, the user is protected from electrical shock, should the motor insulation fail for any reason. When using an extension cord, make sure it is also a 3-wire cable.

CAUTION: Many existing receptacle boxes do not have provision for 3-prong plugs and for this reason an adapter is included with the motor. (This adapter is not used in Canada.) To use the adapter, connect the grounding lead to the box before operating motor (See figure 5).

7. The motor may be operated with a reversing switch (9M2982 in catalog), provided connections are made as shown in figure 6. The motor must come to a complete stop before reversing can be accomplished. If motor rotation does not correspond to switch notations, interchange switch leads 2 and 4.

LUBRICATION AND MAINTENANCE

1. The sleeve bearings in both end shields of this motor have been lubricated at the factory with correct lubricant. No other part of the motor requires lubrication.
2. Re-lubricate motor bearings occasionally at the oil hole located near the top of the hub on each end shield. (See figure 7.) Be sure to wipe off dirt or grit if present around oil holes to prevent any possibility of foreign material contaminating the oil wicks that supply the bearings with oil. Use a good grade of medium weight mineral oil, such as automobile engine oil SAE 20.
3. If disassembly of the motor is necessary, it should be returned to your nearest Sears retail or mail-order store in order to prevent voiding the guarantee.

NOTE: The speed of this motor cannot be regulated or changed.

4. Every effort should be made to prevent foreign material from entering the motor. When operated under conditions likely to permit accumulation of dust, dirt, or waste within the motor, a visual inspection should be made at frequent intervals. Accumulations of dry dust can usually be blown out successfully.

NOTE: Motors used on wood-working tools are particularly susceptible to the accumulation of sawdust and wood chips and should be blown out, or "vacuumed" frequently to prevent interference with normal motor ventilation and proper operation of the centrifugally-operated starting switch.

5. Most motor troubles may be traced to loose or incorrect connections; to overloading; to reduced input voltage which results when small size wires are used in the supply circuit, or when the supply circuit is very long. Always check connections, load and supply circuit when the motor fails to perform satisfactorily. Although the motor is designed for operation on voltage and frequency specified on motor nameplate, normal loads will be handled safely on voltages not more than 10% above or below the nameplate voltage. Heavy loads, however, require that voltage at motor terminals be not less than the voltage specified on nameplate.

6. Common Causes of Low Voltage Are:

- a. Overloading of house or shop circuits with lights, electrical appliances or other motors.
- b. Undersized wires in supply circuits or extension cords.
- c. General overloading of the power company's facilities. (In many sections of the country, demand for electrical power exceeds the capacity of existing generating and distribution systems. If it is suspected that voltage being supplied is low, request a voltage check from the power company.)

7. Some Effects of Low Voltage Are:

- a. Motor fails to develop full power. (The power output of motor decreases rapidly with decrease in voltage at motor terminals. For example: a reduction of 10% in voltage causes a reduction of 19% in maximum power output of which the motor is capable, while a reduction of 20% in voltage causes a reduction of 36% in maximum power output.)
- b. Motor starts slowly or fails to come up to full speed.
- c. Motor overheats.
- d. Motor burns out when operated for long periods of time when overloaded.
- e. Frequent opening of fuses or circuit breakers. (This may also result if motor is overloaded, or if the motor circuit is fused with a fuse other than those recommended. Do not use a fuse of greater capacity without consulting the power company.)

GUARANTEE

This Craftsman Motor was thoroughly inspected and tested before shipment. Should it fail due to faulty material or workmanship, we will repair or replace it, at our option, free of charge if returned to your Sears retail or mail-order store within one year from date of purchase. This guarantee is void if the motor has been tampered with, misused or abused, or if either end shield has been removed in the process of servicing by anyone other than an authorized service station. External parts such as the terminal cover may be removed or replaced without voiding the guarantee.