

SEARS

OWNER'S
MANUAL

MODEL NO.
315.275062

CAUTION:
Read Rules for
Safe Operation
and All Instruc-
tions Carefully

Save This Manual
For Future Reference

Thank You for Buying
Craftsman Tools

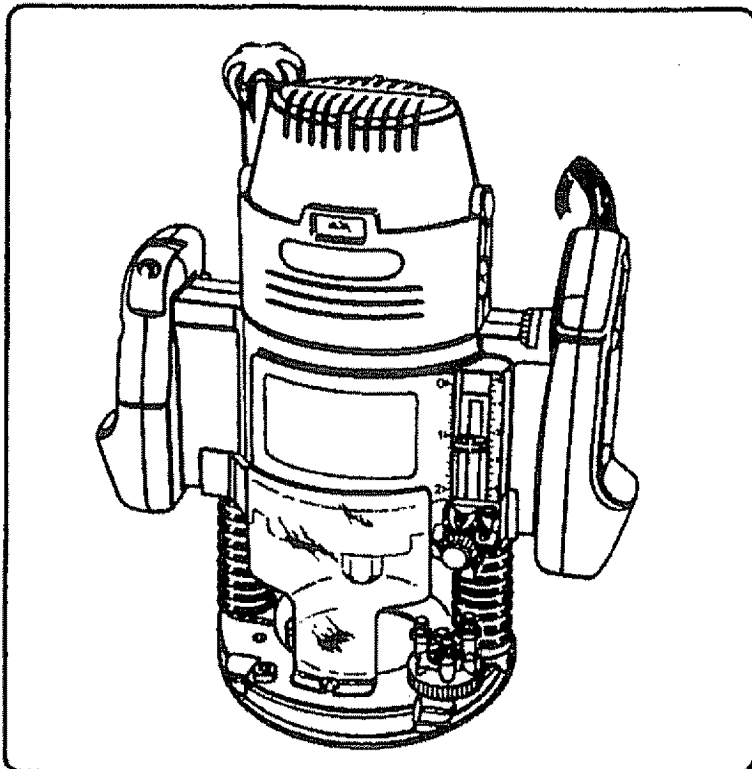

CRAFTSMAN®
Industrial Electronic
Plunge Router
Double Insulated

Warranty
Introduction
Unpacking
Features
Adjustments
Operation
Maintenance
Repair Parts



Designed exclusively for and sold only by
SEARS, ROEBUCK AND CO., Hoffman Estates, IL 60179

Printed in U.S.A.

FULL ONE YEAR WARRANTY ON CRAFTSMAN INDUSTRIAL ELECTRONIC PLUNGE ROUTER

If this Craftsman Industrial Electronic Plunge Router fails due to a defect in material or workmanship within one year from the date of purchase, Sears will repair it free of charge. This warranty applies only while this product is in use in the United States. **WARRANTY SERVICE IS AVAILABLE BY SIMPLY RETURNING THE TOOL TO THE NEAREST SEARS STORE OR SERVICE CENTER THROUGHOUT THE UNITED STATES.**

This warranty gives you specific legal rights, and you may also have other rights which vary from state to state.

SEARS, ROEBUCK AND CO.
DEPT. 817 WA
HOFFMAN ESTATES, IL 60179

INTRODUCTION

DOUBLE INSULATION is a concept in safety, in electric power tools, which eliminates the need for the usual three wire grounded power cord and grounded supply system. Wherever there is electric current in the tool there are two complete sets of insulation to protect the user. All exposed metal parts are isolated from internal metal motor components with protecting insulation.

IMPORTANT - Servicing of a tool with double insulation requires extreme care and knowledge of the system and should be performed only by a qualified service technician. For service we suggest you return the tool to your nearest Sears Store for repair. Always use original factory replacement parts when servicing.

RULES FOR SAFE OPERATION

WARNING: DO NOT ATTEMPT TO OPERATE THIS TOOL UNTIL YOU HAVE READ THOROUGHLY AND UNDERSTAND COMPLETELY ALL INSTRUCTIONS, SAFETY RULES, ETC. CONTAINED IN THIS MANUAL. FAILURE TO COMPLY CAN RESULT IN ACCIDENTS INVOLVING FIRE, ELECTRIC SHOCK, OR SERIOUS PERSONAL INJURY. SAVE OWNERS MANUAL AND REVIEW FREQUENTLY FOR CONTINUING SAFE OPERATION, AND INSTRUCTING OTHERS WHO MAY USE THIS TOOL.

READ ALL INSTRUCTIONS

1. **KNOW YOUR POWER TOOL** - Read owner's manual carefully. Learn its applications and limitations as well as the specific potential hazards related to this tool.
2. **GUARD AGAINST ELECTRICAL SHOCK BY PREVENTING BODY CONTACT WITH GROUNDED SURFACES.** For example: Pipes, radiators, ranges, refrigerator enclosures.
3. **KEEP GUARDS IN PLACE** and in working order.
4. **KEEP WORK AREA CLEAN.** Cluttered areas and benches invite accidents.
5. **AVOID DANGEROUS ENVIRONMENT.** Don't use power tool in damp or wet locations or expose to rain. Keep work area well lit.
6. **KEEP CHILDREN AND VISITORS AWAY.** All visitors should wear safety glasses and be kept a safe distance from work area. Do not let visitors contact tool or extension cord.
7. **STORE IDLE TOOLS.** When not in use tools should be stored in a dry, high or locked-up place - out of the reach of children.
8. **DON'T FORCE TOOL.** It will do the job better and safer at the rate for which it was designed.
9. **USE RIGHT TOOL.** Don't force small tool or attachment to do the job of a heavy duty tool. Don't use tool for purpose not intended - for example - Don't use a circular saw for cutting tree limbs or logs.
10. **WEAR PROPER APPAREL.** No loose clothing or jewelry to get caught in moving parts. Rubber gloves and non-skid footwear are recommended when working outdoors. Also, wear protective hair covering to contain long hair and keep it from being drawn into air vents.
11. **ALWAYS WEAR SAFETY GLASSES.** Everyday eyeglasses have only impact-resistant lenses; they are **NOT** safety glasses.
12. **PROTECT YOUR LUNGS.** Wear a face or dust mask if operation is dusty.
13. **PROTECT YOUR HEARING.** Wear hearing protection during extended periods of operation.
14. **DON'T ABUSE CORD.** Never carry tool by cord or yank it to disconnect from receptacle. Keep cord from heat, oil and sharp edges.

RULES FOR SAFE OPERATION (Continued)

15. **SECURE WORK.** Use clamps or a vise to hold work. Both hands are needed to operate the tool.
16. **DONT OVERREACH.** Keep proper footing and balance at all times. Do not use on a ladder or unstable support
17. **MAINTAIN TOOLS WITH CARE.** Keep tools sharp at all times, and clean for best and safest performance. Follow instructions for lubricating and changing accessories.
18. **DISCONNECT TOOLS.** When not in use, before servicing, or when changing attachments, blades, bits, cutters, etc., all tools should be disconnected from power supply.
19. **REMOVE ADJUSTING KEYS AND WRENCHES.** Form habit of checking to see that keys and adjusting wrenches are removed from tool before turning it on.
20. **AVOID ACCIDENTAL STARTING.** Don't carry plugged-in tools with finger on switch. Be sure switch is off when plugging in.
21. **MAKE SURE YOUR EXTENSION CORD IS IN GOOD CONDITION.** When using an extension cord, be sure to use one heavy enough to carry the current your product will draw. An undersized cord will cause a drop in line voltage resulting in loss of power and overheating. A wire gauge size (A.W.G.) of at least 14 is recommended for an extension cord 25 feet or less in length. A cord exceeding 25 feet is not recommended. If in doubt, use the next heavier gage. The smaller the gage number, the heavier the cord.
22. **OUTDOOR USE EXTENSION CORDS.** When tool is used outdoors, use only extension cords suitable for use outdoors. Outdoor approved cords are marked with the suffix W-A, for example - SJTW-A or SJOW-A.
23. **KEEP CUTTERS CLEAN AND SHARP.** Sharp cutters minimize stalling and kickback.
24. **KEEP HANDS AWAY FROM CUTTING AREA.** Keep hands away from cutters. Do not reach underneath work while cutter is rotating. Do not attempt to remove material while cutter is rotating.
25. **NEVER USE IN AN EXPLOSIVE ATMOSPHERE.** Normal sparking of the motor could ignite fumes.
26. **INSPECT TOOL CORDS PERIODICALLY** and if damaged, have repaired at your nearest Sears Repair Center. Stay constantly aware of cord location.
27. **INSPECT EXTENSION CORDS PERIODICALLY** and replace if damaged.
28. **KEEP HANDLES DRY, CLEAN, AND FREE FROM OIL AND GREASE.** Always use a clean cloth when cleaning. Never use brake fluids, gasoline, petroleum-based products or any strong solvents to clean your tool.
29. **STAY ALERT.** Watch what you are doing and use common sense. Do not operate tool when you are tired. Do not rush.
30. **CHECK DAMAGED PARTS.** Before further use of the tool, a guard or other part that is damaged should be carefully checked to determine that it will operate properly and perform its intended function. Check for alignment of moving parts, binding of moving parts, breakage of parts, mounting, and any other conditions that may affect its operation. A guard or other part that is damaged should be properly repaired or replaced by an authorized service center unless indicated elsewhere in this instruction manual.
31. **DO NOT USE TOOL IF SWITCH DOES NOT TURN IT ON AND OFF.** Have defective switches replaced by an authorized service center.
32. Inspect for and remove all nails from lumber before routing.
33. **DRUGS, ALCOHOL, MEDICATION.** Do not operate tool while under the influence of drugs, alcohol, or any medication.
34. **WHEN SERVICING USE ONLY IDENTICAL CRAFTSMAN REPLACEMENT PARTS.**
35. **POLARIZED PLUGS.** To reduce the risk of electric shock, this tool has a polarized plug (one blade is wider than the other). This plug will fit in a polarized outlet only one way. If the plug does not fit fully in the outlet, reverse the plug. If it still does not fit, contact a qualified electrician to install the proper outlet. Do not change the plug in any way.
36. **DO NOT USE TOOL UNDER "BROWN-OUT" OR OTHER LOW VOLTAGE CONDITIONS.** Also, do not use with any device that could cause the power supply voltage to change.
37. **WHEN USING THIS ROUTER WITH A ROUTER TABLE, HELP PREVENT POSSIBLE SERIOUS INJURY BY KEEPING THE CUTTER GUARDED AT ALL TIMES.** Use only router tables, with guards, that have been designed for use on routers that are of this type, size, and weight.
38. **SAVE THESE INSTRUCTIONS.** Review them frequently and use them to instruct others who may use this tool. If you loan someone this tool, loan them these instructions also.

UNPACKING

Your new plunge router comes fully assembled. After removing it from the box, inspect it carefully to make sure that it is not damaged and that no parts are missing. See Figure 1. The following accessories should also be included in the box:

1. Combination Wrench (3/8 In. - 7/8 In.)
2. 1/4 In. Adapter
3. Edge Guide
4. Roller (Contour) Guide
5. Guide Bushing

WARNING: IF ANY PARTS ARE MISSING DO NOT OPERATE YOUR ROUTER UNTIL THE MISSING PARTS ARE REPLACED. FAILURE TO DO SO COULD RESULT IN POSSIBLE SERIOUS PERSONAL INJURY

FEATURES

Your electronic router is a versatile woodworking tool which will give you years of trouble-free performance. It is engineered with the professional in mind, but its ease of operation allows the amateur to produce work which is beautiful and precise.

3.5 HORSEPOWER MOTOR

Your router has a powerful 3.5 horsepower motor with sufficient power to handle the toughest routing jobs. The motor also has externally accessible brushes for ease of servicing.

SOFT START

The soft start feature builds motor RPM gradually to minimize start-up torque. Pressing or releasing the "on-off" trigger will turn your router on or off.

DEPTH CONTROL KNOB

A large depth control knob makes precise depth of cut changes possible. It also is very helpful when making depth of cut changes with your router mounted upside down on a router table.

DEPTH STOP SYSTEM

The depth stop block located on the base of your router provides three adjustable stops and three fixed stops for quick depth of cut changes. A depth adjustment scale makes quick adjustments to depth of cut changes possible. The spring loaded adjustment knob quick releases stop bar by depressing center of knob.

1/4 IN. AND 1/2 IN. SHANK CAPACITY

Your router has a 1/2 in. diameter collet that accepts cutters with 1/2 in. shanks. An adapter has been provided so that cutters with 1/4 in. shank bits can also be used.

CHIP SHIELD

A clear plastic see-through chip shield has been provided on the base of your router for protection against flying dust and chips. It is designed to fit the front opening of the router base.

POSITLOCK SPINDLE LOCK

A positlock spindle lock secures the spindle so that only one wrench is needed to loosen collet nut and change cutters. A spindle lock indicator light alerts you that spindle is locked if you connect router to power supply before unlocking spindle. **NOTE:** Your router will not run if spindle is locked.

"LOCK-ON" FEATURE"

Your router is equipped with a "lock-on" feature that is convenient when continuous operation for extended periods of time is required.

LARGE HANDLES

Your router has large oversized handles for easy handling and maintaining proper control when routing. The left handle allows you to set cutter depth of cut when making plunge cuts, while the right handle provides easy access to the "on-off" trigger, "lock-on" button, and variable speed control selector. The handles have also been designed so that they are comfortable and easy to grasp when operating in different positions or at different angles.

VARIABLE SPEED SWITCH WITH ELECTRONIC SPEED CONTROL (Feedback Switch)

Your router has advanced electronic features, designed to assist you in getting the maximum use from your router. By making proper speed selections, your router can be adjusted to specific routing needs. This eliminates much of the guess work previously needed to perform a given job. Both the experienced and inexperienced router users benefit, obtaining professional like results with fewer job errors.

The variable speed control allows the router speed to be adjusted from 10,000 to 25,000 rpm. The variable speed control selector is conveniently located inside the right handle near the operator's thumb or hand.

The electronic feature of your router introduces the flexibility of adjusting the motor speed to required job conditions. An electronic speed control module senses the load applied to the motor, and increases or decreases motor voltage to compensate for and maintain desired RPM.

Speed can be set according to the approximate cutter diameter you will be using and to the hardness of the material being cut. The best cuts are made when the cutter is fed through material at the proper rate of feed.

ROUTER ACCESSORIES

Your router comes equipped with several accessories. The edge guide keeps the cutter parallel with an edge of the workpiece when cutting grooves and rabbets. The roller (contour) guide allows the router to be used to trim laminates and make cuts parallel with an irregularly shaped edge. The template guide bushing enables the router to follow a template for making duplicate shapes.

FEATURES

KNOW YOUR ELECTRONIC ROUTER

Before attempting to use your router, familiarize yourself with all operating features and safety requirements. See Figures 1 and 2.

WARNING: DO NOT ALLOW FAMILIARITY WITH YOUR ROUTER TO MAKE YOU CARELESS. REMEMBER THAT A CARELESS FRACTION OF A SECOND IS SUFFICIENT TO INFLICT SEVERE INJURY.

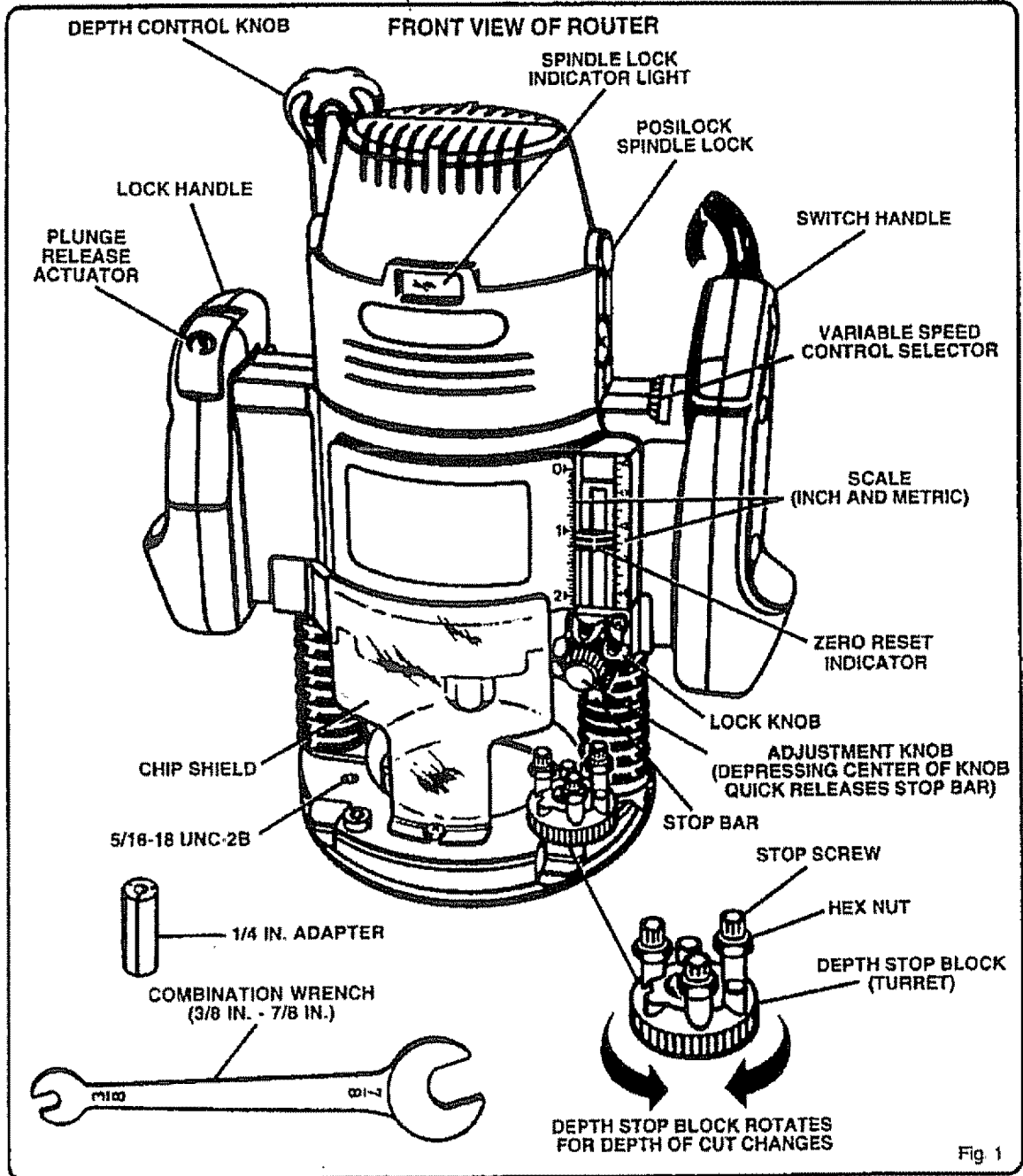

FEATURES

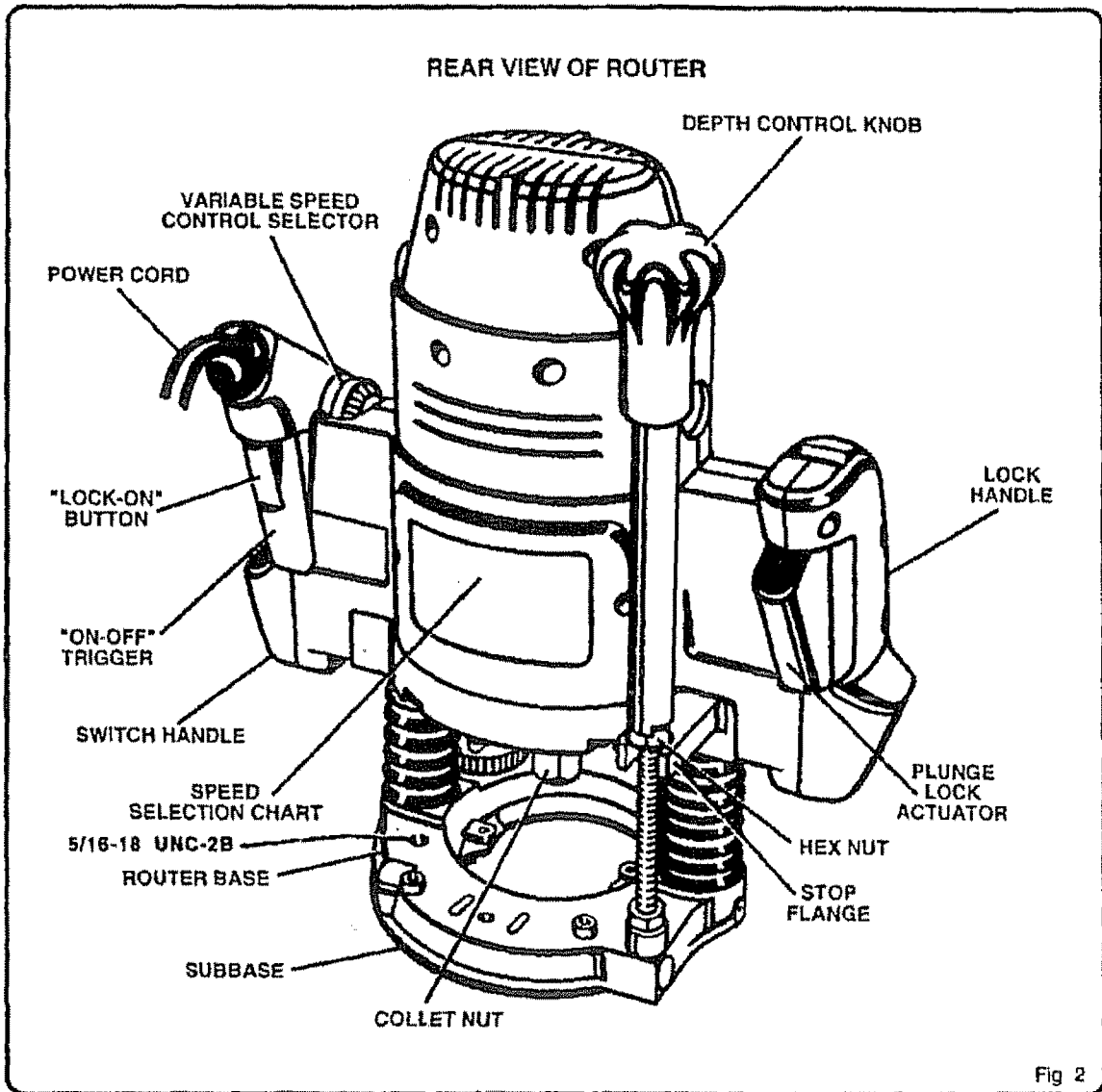

ELECTRICAL CONNECTION

Your router has a precision built electric motor. It should be connected to a power supply that is 120 volts, 60 Hz, AC only (normal household current). Do not operate this tool on direct current (DC). A voltage drop of more than 10 percent will cause a loss of power and overheating. If your tool does not operate when plugged into an outlet, double-check the power supply.

WARNING:



The operation of any router can result in foreign objects being thrown into your eyes, which can result in severe eye damage. Before beginning power tool operation, always wear safety goggles or safety glasses with side shields and a full face shield when needed. We recommend Wide Vision Safety Mask for use over eyeglasses or standard safety glasses with side shields, available at Sears Retail Stores.

ADJUSTMENTS

WARNING: YOUR ROUTER SHOULD NEVER BE CONNECTED TO POWER SUPPLY WHEN YOU ARE ASSEMBLING PARTS, MAKING ADJUSTMENTS, INSTALLING OR REMOVING CUTTERS, OR WHEN NOT IN USE. DISCONNECTING YOUR ROUTER WILL PREVENT ACCIDENTAL STARTING THAT COULD CAUSE SERIOUS INJURY.

INSTALLING/REMOVING CUTTERS

See Figures 3, 4, and 5.

1. UNPLUG YOUR ROUTER.

WARNING: FAILURE TO UNPLUG YOUR ROUTER COULD RESULT IN ACCIDENTAL STARTING CAUSING SERIOUS INJURY.

2. Place the posilock spindle lock into lock position. See Figure 3. **NOTE:** If spindle does not lock, turn collet nut with wrench, applying pressure at the same time to the spindle lock with your thumb or finger. When lock mechanism engages with notch in spindle, spindle lock will slide into lock position.

WARNING: TO PREVENT DAMAGE TO THE SPINDLE OR SPINDLE LOCK, DO NOT ATTEMPT TO ENGAGE SPINDLE LOCK WHILE MOTOR IS RUNNING. ALWAYS ALLOW MOTOR TO COME TO A COMPLETE STOP AND UNPLUG IT BEFORE ENGAGING SPINDLE LOCK.

3. Place router upside down on workbench or lay it face down on its side in order to gain easy access to collet nut.
4. Place 7/8 in. end of the combination wrench provided through back of router base onto collet nut and turn counterclockwise to loosen. See Figure 4.

WARNING: IF YOU ARE CHANGING A CUTTER IMMEDIATELY AFTER USE, BE CAREFUL NOT TO TOUCH CUTTER OR COLLET WITH YOUR HANDS OR FINGERS. THEY WILL GET BURNED BECAUSE OF THE HEAT BUILDUP FROM CUTTING. ALWAYS USE THE WRENCH PROVIDED.

5. If installing cutter for the first time, it can be installed once collet nut is loose. If changing cutters, cutter will easily slip from collet after loosening collet nut.
6. The collet is machined to precision tolerances to fit cutters with 1/2 in. diameter shanks. If using a cutter with a 1/4 in. diameter shank, place the 1/4 in. adapter provided in the collet. See Figure 5.
7. Insert shank of cutter into collet until shank bottoms out, then pull it out 1/16 in. to allow for expansion when the bit gets hot.
8. Tighten the collet nut securely by turning clockwise with the wrench provided. See Figure 4.

WARNING: IF COLLET NUT IS NOT TIGHTENED SECURELY, CUTTER MAY COME OUT DURING USE CAUSING SERIOUS PERSONAL INJURY.

9. Place posilock spindle lock back in unlock position. Otherwise, interlocking mechanism of spindle lock will not let you turn your router on. If you forget, the spindle lock indicator light will alert you that spindle is still locked when you connect router to power supply.

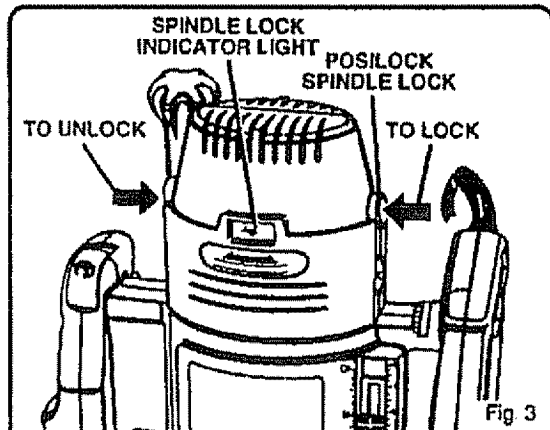

Fig. 3

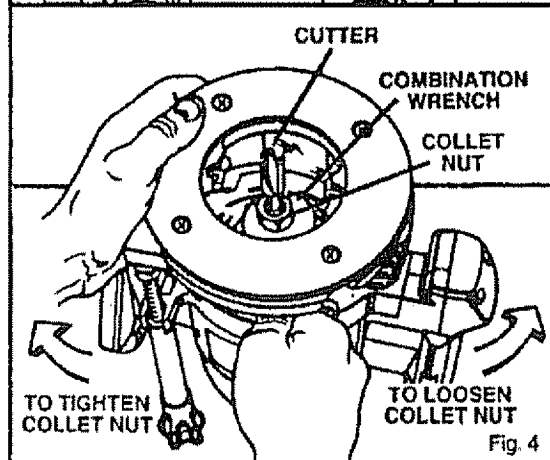

Fig. 4

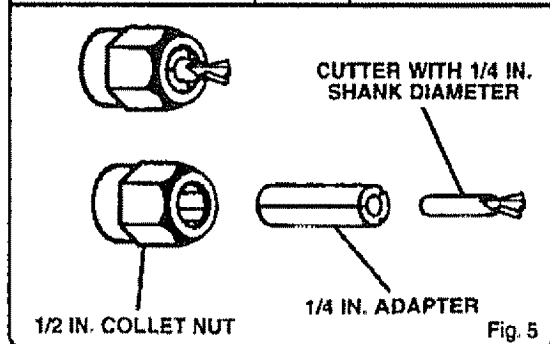

Fig. 5

WARNING: DO NOT USE CUTTERS WITH UNDERSIZED SHANKS. UNDERSIZED SHANKS WILL NOT TIGHTEN PROPERLY AND COULD BE THROWN FROM TOOL CAUSING INJURY.

ADJUSTMENTS

DEPTH OF CUT ADJUSTMENTS

See Figures 6, 7 and 8.

When routing a groove that is too deep to safely cut in one pass, it is best to make the cut in several passes. We recommend that cuts be made at a depth not exceeding 1/8 in. and that several passes be made to reach deeper cuts.

Proper depth of cut depends on several factors: horsepower of router motor, type of cutter being used, and type of wood being routed. A lightweight, low horsepower router is designed for making shallow cuts. A router with high horsepower rating can safely cut deeper. Small bits, such as 1/4 in. shank veining bits with 1/16 in. cutting diameters, are designed to remove only small amounts of wood. Large bits, such as 1/2 in. shank straight-flute bits, are made to remove larger amounts of wood in a single pass. Cuts can be made deeper in soft woods, such as white pine, than in tough hardwoods, like oak or maple. Based upon these considerations, choose a depth of cut that will not place excessive strain on router motor. If you find that extra force is needed or that the motor speed slows down considerably, turn off router and raise the bit. Then, make the cut in two or more passes.

TO SET DEPTH OF CUT

1. UNPLUG YOUR ROUTER.

WARNING: FAILURE TO UNPLUG YOUR ROUTER COULD RESULT IN ACCIDENTAL STARTING CAUSING SERIOUS INJURY.

2. Raise cutter by depressing plunge release actuator. See Figure 6.
3. Adjust depth control knob until cutter is inside router subbase. See Figure 7.
4. Place router on a flat surface.
5. Lower router until tip of cutter barely touches flat surface. See Figure 8.
6. Squeeze plunge lock actuator to lock cutter at "zero" depth of cut. **NOTE:** If desired, adjust depth control knob until hex nut comes in contact with stop flange. This will provide a positive stop at "zero" depth of cut.
7. Rotate depth stop block to desired position, loosen lock knob, then turn adjustment knob until stop bar touches stop screw on depth stop block.
8. Slide zero-reset indicator up or down the scale on stop bar until white line on zero-reset indicator aligns with a desired reference point. For example, align white line with 1 in. mark on the scale.
9. Next, turn adjustment knob in the opposite direction, lifting stop bar to obtain desired depth of cut. See Figure 8. For example, if setting 1/8 in. depth of cut, the zero-reset indicator will move 1/8 in. from the 1 in. reference point.
10. Tighten lock knob securely.
11. Position your router so that the cutter can extend below the subbase for desired depth setting.
12. Depress plunge release actuator.
13. Grasp handles and lower router until stop bar contacts stop screw. Squeeze plunge lock actuator, locking cutter at desired depth of cut. See Figure 9.

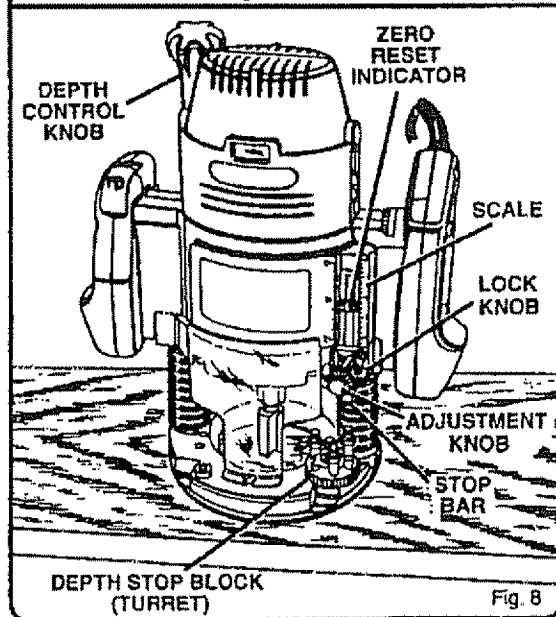
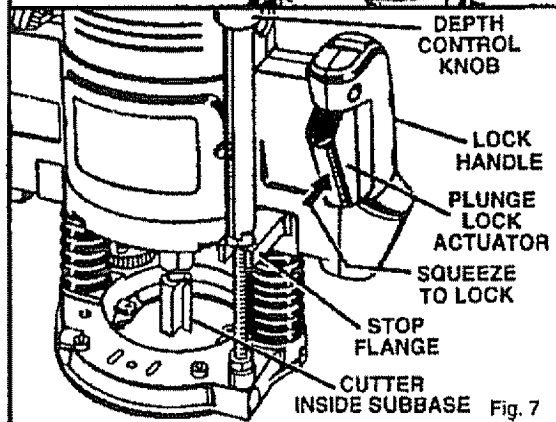
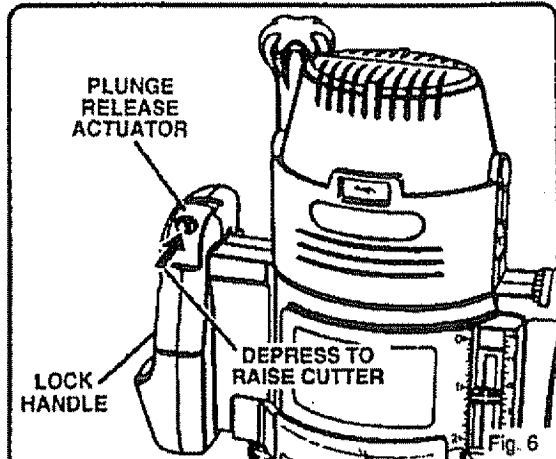

ADJUSTMENTS

DEPTH CONTROL KNOB

See Figure 9.

Fine adjustments can be made to the depth of cut by use of the depth control knob. Another primary use of the depth control knob is setting depth of cut when router is mounted upside down on a router table. **NOTE:** The weight of the router plus the awkward position it is in when mounted to a router table make it necessary to use depth control knob.

TO SET DEPTH OF CUT WITH DEPTH CONTROL KNOB

1. UNPLUG YOUR ROUTER.

WARNING. FAILURE TO UNPLUG YOUR ROUTER COULD RESULT IN ACCIDENTAL STARTING CAUSING SERIOUS INJURY.

2. Loosen lock knob and turn adjustment knob so that stop bar is not touching stop screws or fixed stops.
3. Depress plunge release actuator and allow router to return to its uppermost position against hex nut.
4. Plunge router until cutter reaches the approximate desired depth of cut. Then squeeze plunge lock actuator, temporarily locking cutter at desired depth of cut.
5. Turn depth control knob clockwise until hex nut seats against stop flange. Do not overtighten hex nut against stop flange.
6. Depress plunge release actuator and turn depth control knob until cutter reaches desired depth of cut. Always make sure plunge lock is released and router is free before setting depth of cut with depth control knob.
7. Squeeze plunge lock actuator, locking cutter at desired depth of cut.
8. Turn adjustment knob and adjust stop bar until it touches the desired stop screw or fixed stop.
9. Tighten lock knob securely.

Depth control knob is spring loaded against hex nut. If you adjust it too far and it pops off threaded rod, refer to **DEPTH CONTROL KNOB ADJUSTMENTS** in maintenance section for proper reassembly.

DEPTH STOP SYSTEM

See Figure 10

The depth stop block located on the base of your router makes it possible to make deep or heavy cuts in successive passes by use of preset depth of cut changes. Both fixed and adjustable stops are provided, making depth of cut changes quick and easy. The depth stop block, also known as a revolving turret, rotates on a ball detent design in the router base.

A preset cutting depth is achieved by plunging router until stop bar comes in contact with the stop screw or fixed stop on depth stop block.

The fixed stops are approximately 1/8 in. apart. The adjustable stops have screws that may be adjusted approximately 1/2 in.

TO SET DEPTH STOP BLOCK SETTINGS

UNPLUG YOUR ROUTER.

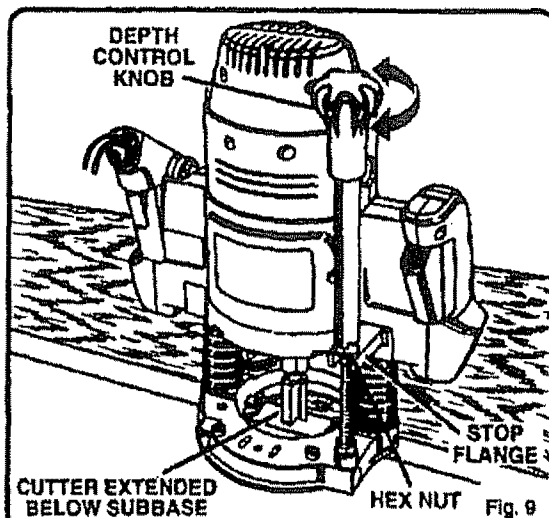

Fig. 9

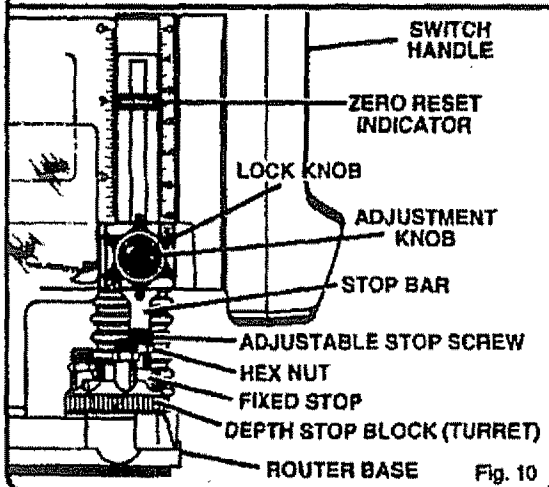

Fig. 10

WARNING. FAILURE TO UNPLUG YOUR ROUTER COULD RESULT IN ACCIDENTAL STARTING CAUSING SERIOUS INJURY.

2. Loosen lock knob and turn adjustment knob clockwise, raising stop bar to its highest position.
3. Determine which stop, adjustable or fixed, to use for the desired depth of cut. A combination of the two stop types can be used if required for a specific job. If using the adjustable stops, the stop screw on each stop can be adjusted to the desired height by loosening hex nut with the 3/8 in. end of combination wrench supplied, and turning it in or out with your fingers. Secure stop screw in position by retightening hex nut with wrench. Do not overtighten hex nut. Set stops to desired heights, spreading the entire depth of cut over the number of stops used.
4. Rotate depth stop block until the highest depth stop is aligned with the stop bar.

ADJUSTMENTS

DEPTH STOP SYSTEM (Continued)

5. Raise cutter by depressing plunge release actuator.
6. Place router on flat surface, and lower router until tip of cutter barely touches flat surface.
7. Squeeze plunge lock actuator to lock cutter at "zero" depth of cut.
8. Turn adjustment knob counterclockwise to lower stop bar against the stop, then tighten lock knob securely. The highest stop now becomes the "zero" depth of cut setting.
9. Depress plunge release actuator and raise router. Rotate stop block so that next highest depth stop aligns with stop bar. This locates cutter for the initial pass.
10. Rotate depth stop block after each pass. Make as many successive passes as needed to obtain desired depth of cut, progressively lowering router to next depth of cut setting with each pass.

ZERO RESET INDICATOR

See Figure 11.

The zero reset indicator allows you to use the scale provided on the housing to make quick depth of cut changes to existing depth of cut settings. Simply choose a reference point on the scale and slide zero reset indicator up or down scale the distance required for new depth of cut. Then change stop bar position by loosening lock knob and turning adjustment knob until white line on zero reset indicator moves back to reference point. Tighten lock knob securely to lock stop bar in new position. The cutter position will now increase or decrease the exact distance the stop bar was adjusted.

Remember: Each mark on the inch scale indicates a 1/32 inch change in depth setting while each mark on the metric scale equals a 1mm change in depth setting.; depth control knob should be used for making precise adjustments to depth of cut; and depressing center of depth adjustment knob quick releases stop bar.

VARIABLE SPEED CONTROL SELECTOR

See Figure 12.

Your router has a variable speed control selector designed to allow operator control of speed and torque limits. You can make speed selections best suited to the type of cut, the material being cut, and the size of bit being used. The variable speed control selector allows you to adjust router speed from 10,000 to 25,000 rpm. There is a six step scale lettered A to F on the variable speed control selector. To increase the speed and torque of your router, turn the variable speed control selector to a higher setting. Turn to a lower setting to decrease speed and torque. **NOTE:** If you do not want to use the variable speed control selector, turn to the highest possible setting, and the feature will not be active.

The speed selection chart shown gives suggested speed settings based on the diameter of the cutter and the type of material being routed.

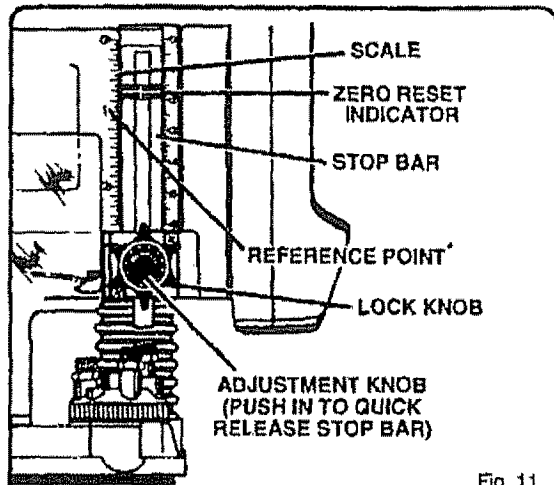

Fig 11

SPEED SELECTION CHART

MAT'L	CUTTER SIZE					
	1/4"	3/8"	1/2"	3/4"	1"	1 1/4"
SOFT	A	B-C	C-D	D-E	E-F	F
MEDIUM	A	B	C	B-C	B-C	B-C
HARD	D-E	C	C	C	C	C
VERY HARD	D	A-B	A	A	A	A

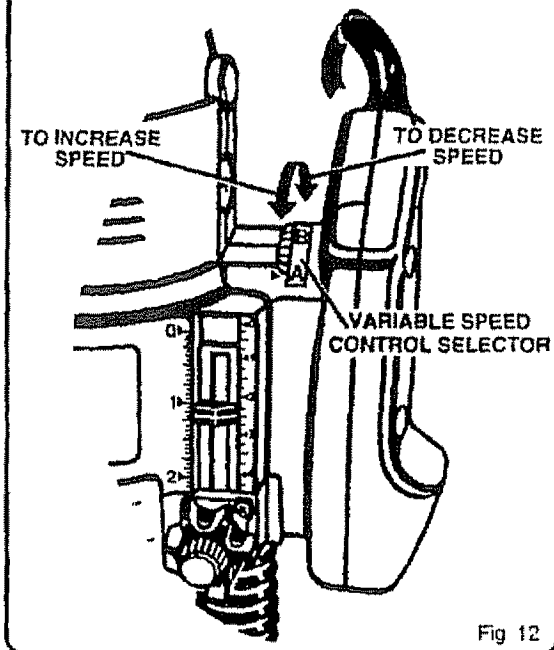

Fig 12

PRACTICE BEFORE ACTUAL USE

See Figure 12.

We suggest that you practice with the variable speed feature of your router before installing a cutter and making cuts in wood.

OPERATION

WARNING: ALWAYS WEAR SAFETY GOGGLES OR SAFETY GLASSES WITH SIDE SHIELDS WHEN USING YOUR ROUTER. FAILURE TO DO SO COULD RESULT IN DUST, SHAVINGS, CHIPS, LOOSE PARTICLES OR FOREIGN OBJECTS BEING THROWN IN YOUR EYES RESULTING IN POSSIBLE SERIOUS INJURY. IF THE OPERATION IS DUSTY, ALSO WEAR A FACE OR DUST MASK.

"LOCK-ON" BUTTON

See Figure 13.

The "on-off" trigger of your router is equipped with a "lock-on" feature which is convenient when operating for extended periods of time. The "lock-on" button is located in the upper portion of the "on-off" trigger. It works similar to a rocker switch. To lock on, fully depress "on-off" trigger, then depress "lock-on" button in top of "on-off" trigger and release. You will feel the "lock-on" button as it snaps "on-off" trigger into lock position. To release the lock, depress "on-off" trigger at any point along trigger body, or depress protruding portion of the "lock-on" button.

WARNING: BEFORE CONNECTING ROUTER TO POWER SUPPLY SOURCE. ALWAYS CHECK TO BE SURE SWITCH IS NOT IN "LOCK-ON" POSITION. FAILURE TO DO SO COULD RESULT IN ACCIDENTAL STARTING OF YOUR ROUTER RESULTING IN POSSIBLE SERIOUS INJURY

ROUTING

See Figure 14.

For ease of operation and maintaining proper control, your router has two handles, one on each side of the router base. When using your router hold it firmly with both hands as shown in figure 14.

Before starting router, make sure cutter is securely tightened in collet nut and that depth of cut is properly set.

Turn router on and let motor build to its full speed, then gradually plunge or feed cutter into workpiece. **DO NOT** let the cutter contact workpiece before turning on router and allowing it to develop full speed.

Remain alert and watch what you are doing. **DO NOT** operate router when fatigued.

FEED DIRECTION

When routing, the cutter rotates clockwise. Therefore, you should feed the router into the workpiece from left to right. When fed from left to right, the rotation of the cutter pulls the router against the workpiece. If fed in the opposite direction, the rotation forces of the spinning bit will tend to throw the router away from the workpiece. This could cause loss of control of your router.

RATE OF FEED

IMPORTANT: The whole "secret" of professional routing and edge shaping lies in making a careful set-up for the cut to be made and in selecting the proper rate of feed.

The proper rate of feed depends on several factors: the hardness and moisture content of the wood, the depth of cut, and the cutting diameter of the bit. When cutting shallow grooves in soft woods such as pine, a faster rate of feed can

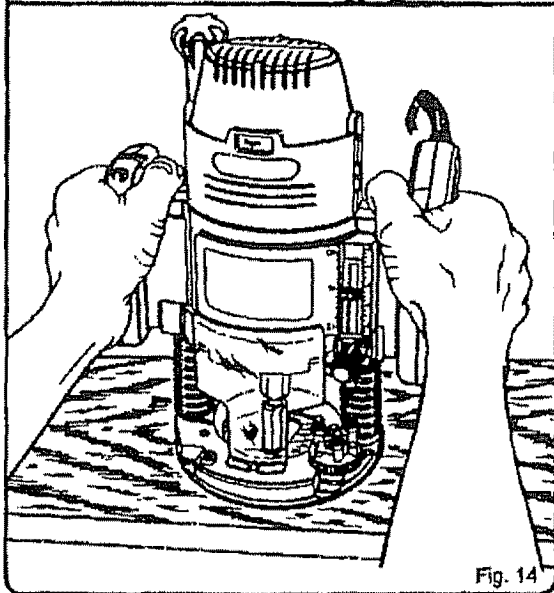
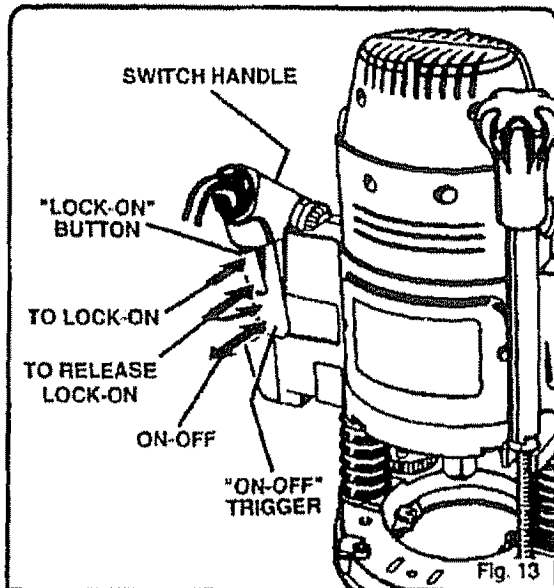

be used. When making deep cuts in hardwoods such as oak, a slower rate of feed will be required.

The best rate of feed is one that does not slow down the router motor more than one-third of its no-load speed. If the router is fed too fast, it will take large chips out of the wood and leave gouge marks. If the router is fed too slow, it will scorch or burn the wood.

OPERATION

PROPER FEEDING

The right feed is neither too fast nor too slow. It is the rate at which the bit is being advanced firmly and surely to produce a continuous spiral of uniform chips — without hogging into the wood to make large individual chips or, on the other hand, to create only sawdust. If you are making a small diameter, shallow groove in soft, dry wood, the proper feed may be about as fast as you can travel your router along your guide line. On the other hand, if the bit is a large one, the cut is deep or the wood is hard to cut, the proper feed may be a very slow one. Then, again, a cross-grain cut may require a slower pace than an identical with grain cut in the same workpiece.

There is no fixed rule. You will learn by experience from practice and use. The best rate of feed is determined by listening to the sound of the router motor and by feeling the progress of each cut. If at all possible, always test a cut on a scrap piece of the workpiece wood, beforehand.

SPEED SELECTION

In general, if the material being cut is hard, the cutter size is large, or the depth of cut is deep (maximum 1/8 in.), then your router should be run at slower speeds. When these situations exist, turn the variable speed control selector until the desired speed is reached. **NOTE:** Carbide cutters cut at higher speeds than steel cutters and should be used when cutting very hard materials.

FORCE FEEDING

Clean, smooth routing and edge shaping can be done only when the bit is revolving at a relatively high speed and is taking very small bites to produce tiny, cleanly severed chips. If your router is forced to move forward too fast, the RPM of the bit becomes slower than normal in relation to its forward movement. As a result, the bit must take bigger bites as it revolves. "Bigger bites" mean bigger chips, and a rougher finish. Bigger chips also require more power, which could result in the router motor becoming overloaded.

Under extreme force-feeding conditions the relative RPM of the bit can become so slow — and the bites it has to take so large — that chips will be partially knocked off (rather than fully cut off), with resulting splintering and gouging of the workpiece. See Figure 15.

Your Craftsman router is an extremely high-speed tool (25,000 RPM no-load speed), and will make clean, smooth cuts if allowed to run freely without the overload of a forced (too fast) feed. Three things that cause "force feeding" are bit size, depth-of-cut, and workpiece characteristics. The larger the bit or the deeper the cut, the more slowly the router should be moved forward. If the wood is very hard, knotty, gummy or damp, the operation must be slowed still more.

You can always detect "force feeding" by the sound of the motor. Its high-pitched whine will sound lower and stronger as it loses speed. Also, the strain of holding the tool will be noticeably increased.

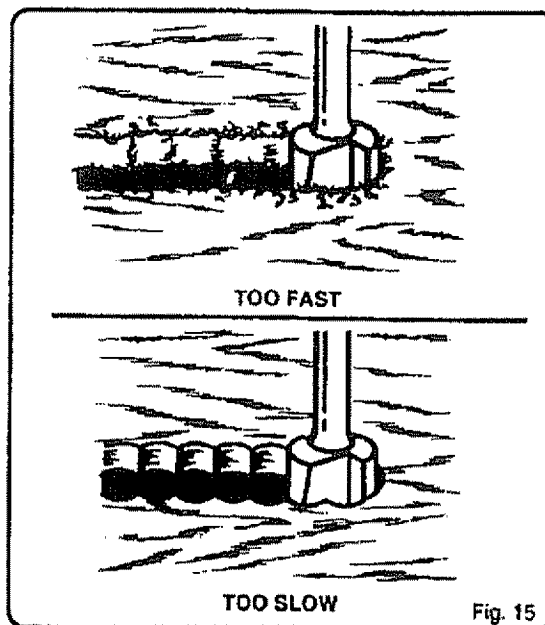

TOO SLOW FEEDING

It is also possible to spoil a cut by moving the router forward too slowly. When it is advanced into the work too slowly, a revolving bit does not dig into new wood fast enough to take a bite; instead, it simply scrapes away sawdust-like particles. Scraping produces heat, which can glaze, burn, or mar the cut — in extreme cases, can even overheat the bit so as to destroy its hardness.

In addition, it is more difficult to control a router when the bit is scraping instead of cutting. With practically no load on the motor the bit will be revolving at close to top RPM, and will have a much greater than normal tendency to bounce off the sides of the cut (especially, if the wood has a pronounced grain with hard and soft areas). As a result, the cut produced may have rippled, instead of straight sides. See Figure 15.

"Too-slow feeding" can also cause your router to take off in a wrong direction from the intended line of cut. **Always grasp and hold your router firmly with both hands when routing.**

You can detect "too-slow feeding" by the runaway too-highly pitched sound of the motor; or by feeling the "wobble" of the bit in the cut.

OPERATION

DEPTH OF CUT

As previously mentioned, the depth of cut is important because it affects the rate of feed which, in turn, affects the quality of a cut (and, also, the possibility of damage to your router motor and bit). A deep cut requires a slower feed than a shallow one, and a too deep cut will cause you to slow the feed so much that the bit is no longer cutting, it is scraping, instead.

Making a deep cut is never advisable. The smaller bits — especially those only 1/16 inch in diameter — are easily broken off when subjected to too much side thrust. A large enough bit may not be broken off, but if the cut is too deep a rough cut will result — and it may be very difficult to guide and control the bit as desired. For these reasons, we recommend that you do not exceed 1/8 inch depth of cut in a single pass, regardless of the bit size or the softness or condition of the workpiece. See Figure 16.

To make deeper cuts it is therefore necessary to make as many successive passes as required, lowering the bit 1/8 inch for each new pass. In order to save time, do all the cutting necessary at one depth setting, before lowering the bit for the next pass. This will also assure a uniform depth when the final pass is completed. See Figure 17.

DIRECTION OF FEED AND THRUST

See Figure 18.

The router motor and bit revolve in a clockwise direction. This gives the tool a slight tendency to twist (in your hands) in a counterclockwise direction, especially when the motor revs up (as at starting).

Because of the extremely high speed of bit rotation during a "proper feeding" operation, there is very little kickback to contend with under normal conditions. However, should the bit strike a knot, hard grain, foreign object, etc. that would affect the normal progress of the cutting action, there will be a slight kickback — sufficient to spoil the trueness of your cut if you are not prepared. Such a kickback is always in the direction opposite to the direction of bit rotation.

To guard against such a kickback, plan your set-up and direction of feed so that you will always be thrusting the tool — to hold it against whatever you are using to guide the cut — in the same direction that the leading edge of the bit is moving. In short, the thrust should be in a direction that keeps the sharp edges of the bit continuously biting straight into new (uncut) wood.

ROUTING

Whenever you are routing a groove, your travel should be in a direction that places whatever guide you are using at the right-hand side. In short, when the guide is positioned as shown in the first part of Figure 19, tool travel should be left to right and counterclockwise around curves. When the guide is positioned as shown in the second part of Figure 19 tool travel should be right to left and clockwise around curves. If there is a choice, the first set-up is generally the easiest to use. In either case, the sideways thrust you use is against the guide.

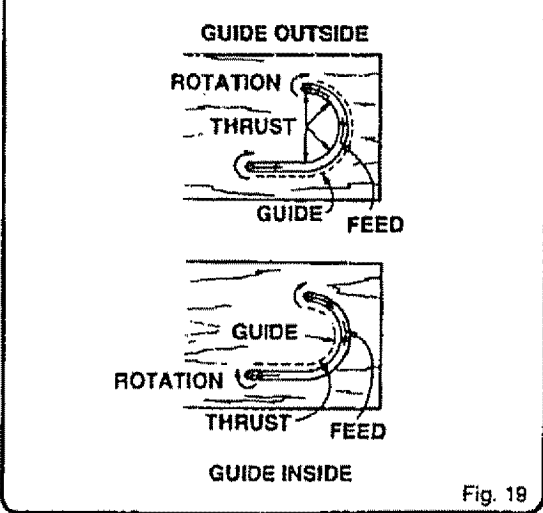
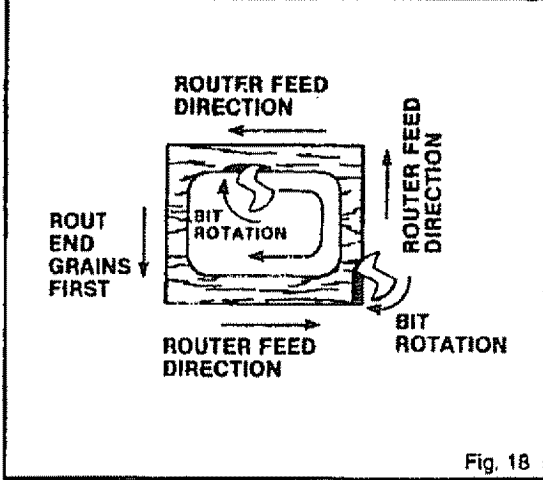
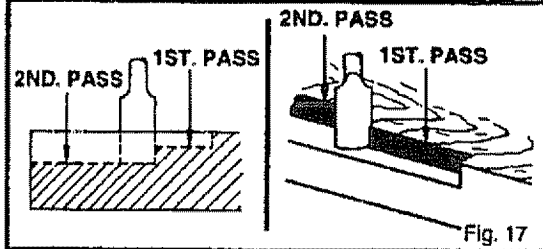
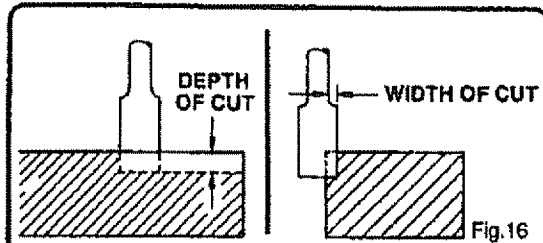

OPERATION

EDGE ROUTING

Place router on workpiece, making sure the router bit does not contact workpiece. Turn router on and let motor build to its full speed. Begin your cut, gradually feeding cutter into workpiece.

WARNING: KEEP A FIRM GRIP ON ROUTER WITH BOTH HANDS AT ALL TIMES. FAILURE TO DO SO COULD RESULT IN LOSS OF CONTROL LEADING TO POSSIBLE SERIOUS INJURY.

Upon completion of cut, turn motor off and let it come to a complete stop before removing router from work surface.

WARNING: NEVER PULL ROUTER OUT OF WORK AND PLACE UPSIDE DOWN ON WORK SURFACE BEFORE THE CUTTER STOPS.

EDGING WITH PILOT BITS

See Figure 20.

Rabbets and molded edges can be cut using piloted cutters. The pilot extends below the cutter. Some pilots are solid extensions of the cutter. Others are ball bearing guides that are fastened to the end of the cutter. The pilots allow the cutters to turn while the pilot follows the edge of the workpiece.

Arbor-type bits with pilots are excellent for quick, easy, edge shaping. They will follow workpiece edges that are either straight or curved. The pilot prevents the bit from making too deep a cut, and holding the pilot firmly in contact with the workpiece edge throughout prevents the cut from becoming too shallow.

Whenever the workpiece thickness together with the desired depth of cut (as adjusted by router depth setting) are such that only the top part of the edge is to be shaped (leaving at least a 1/16 inch thick uncut portion at bottom), the pilot can ride against the uncut portion, which will serve to guide it. See Figure 20. However, if the workpiece is too thin or the bit set too low so that there will be no uncut edge to ride the pilot against, an extra board to act as a guide must be placed under the workpiece. This "guide" board must have exactly the same contour — straight or curved — as the workpiece edge. If it is positioned so that its edge is flush with the workpiece edge, the bit will make a full cut (in as far as the bit radius). On the other hand, if the guide is positioned as shown in Figure 20 (out from the workpiece edge), the bit will make less than a full cut — which will alter the shape of the finished edge.

NOTE: If desired, any of the piloted bits can be used without a pilot for edge shaping with guides, as preceding. Also, the size (diameter) of the pilot that is used determines the maximum cut width that can be made with the pilot against the workpiece edge (the small pilot exposes all of the bit; the large one reduces this amount by 1/16 inch).

When routing all the edges of a panel or board, rout the end grain first. Any splintering that occurs at the corners will then be removed when routing the edge. Start each side 1/4 in.

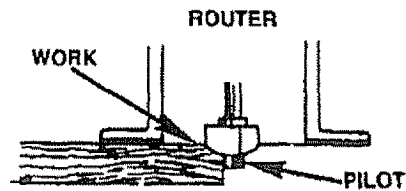

TOP EDGE SHAPING

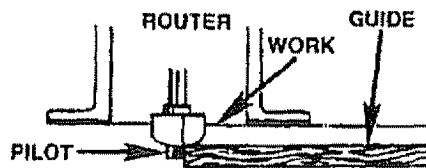

WHOLE EDGE SHAPING Fig. 20

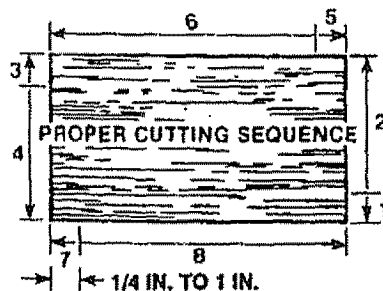

Fig. 21

away from the end. Feed the cutter into the wood until the pilot contacts the uncut edge. Then, slowly back the router to shape the corner. Next, move the router forward to shape the rest of the edge. Be careful to keep the pilot pressed against the uncut edge. Repeat this procedure on each side of the panel. Figure 21 shows the proper sequence of cuts to make when edge routing four sides of a panel.

OPERATION

ROUTING GROOVES

See Figure 22.

When routing across the face of boards, set router at desired depth of cut, place the edge of router base against workpiece, and turn on your router. Slowly feed the cutter into the workpiece along desired cutline.

WARNING: IF DESIRED DEPTH OF CUT IS GREATER THAN CAN BE SAFELY CUT IN ONE PASS, MAKE CUTS IN TWO OR MORE PASSES.

When routing straight cuts across stock, clamp a straightedge to the workpiece to use as a guide. Position the straightedge parallel to the cutline and offset the distance between the cutting edge of the cutter and the edge of the router base. Hold the router base against the straightedge and rout the groove.

When routing a groove wider than the diameter of the cutter, clamp a straightedge on both sides of the cutting line. Position both guides parallel to the desired cutline and spaced equal distances from the desired edges of the groove. Rout along one guide; then, reverse direction and rout along the other guide. Clean out any remaining waste in the center of the groove freehand.

ROUTING WITH EDGE GUIDE

See Figures 23 and 24.

Straight cuts and grooves can also be routed using an edge guide attachment on your router. The edge guide attaches to a guide holder, then the guide bars fit into openings in the router base. Knob screws in the base secure the guide bars in position.

Adjustments are made by loosening the wing bolt on guide holder, placing the edge guide the desired distance from the cutter, then retightening wing bolt. Fine adjustments can be made with edge guide adjustment knob on the end of guide holder. When routing with the edge guide attachment, hold edge guide against the edge of workpiece as shown in figure 24.

ROUTING CIRCLES WITH EDGE GUIDE

See Figure 25.

The edge guide attachment can be used for routing circles when a piloted bit is not available or inadequate for the required job. Position the edge guide so that the cutter is in the center opening of the edge guide. Keep both corners of edge guide pressed against the edge to maintain a consistent shape.

When routing the outside edge (perimeter) of a circle, feed the router counterclockwise. When routing the inside of a circle feed the router clockwise as shown in figure 25.

Remember that the rotation of the bit must always lead into the workpiece rather than away from it.

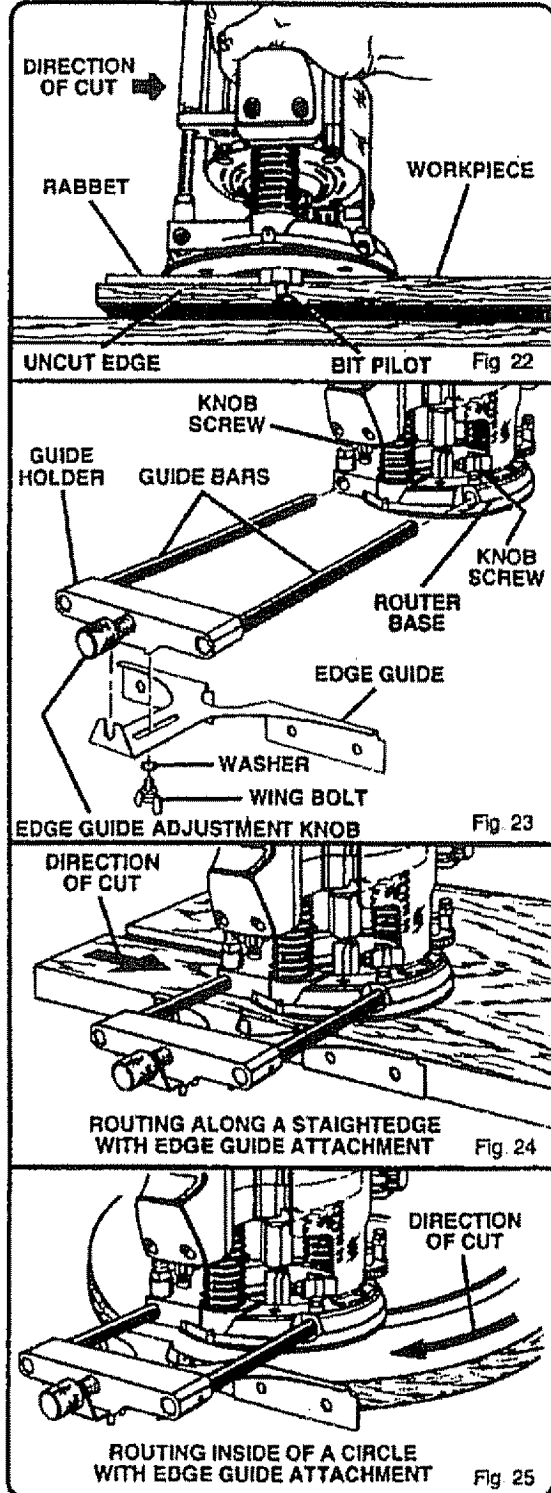

OPERATION

ROUTING WITH A ROLLER GUIDE

See Figures 26 and 27.

A roller guide has been supplied with your router. It is useful for routing uneven edges and trimming laminates.

The roller guide attaches to the guide holder as shown in figure 26. It can be adjusted in and out as well as up and down. The roller guide rides against the uncut edge of the workpiece.

When routing a decorative groove along an uneven edge, the distance from roller guide to cutter should be the same as the distance from the desired cut and the edge of the workpiece. Fine adjustments can be made with the edge guide adjustment knob on guide holder. **Tighten wing bolts securely.** When routing, keep roller pressed tight against edge of workpiece. Carefully follow desired line of cut so that the distance between the cut and the edge does not vary.

When trimming laminates with the roller guide, use a straight cutting bit or a roundnose bit. Position the roller guide even with the inside cutting edge of router bit. The roller guide follows the edge of the workpiece while the bit trims off the overhanging laminate. See Figure 27.

ROUTING WITH GUIDE BUSHINGS

See Figures 28 and 29.

You can accurately duplicate curves and complex shapes by fitting your router with a template guide bushing that extends below the subbase. The router bit passes through the guide bushing. The guide bushing then rides against a template.

TO INSTALL TEMPLATE GUIDE BUSHING:

1. UNPLUG YOUR ROUTER.

WARNING: FAILURE TO UNPLUG YOUR ROUTER COULD RESULT IN ACCIDENTAL STARTING CAUSING SERIOUS INJURY.

2. Place router upside down on workbench
3. Place template guide bushing in recessed portion of router base as shown in figure 28.
4. Align the cutouts in guide bushing with threaded holes in base.
5. Secure guide bushing to router base with roundhead screws provided.
6. Tighten screws securely.

WARNING: FAILURE TO TIGHTEN SCREWS COULD CAUSE BIT TO COME IN CONTACT WITH BUSHING RESULTING IN SERIOUS INJURY.

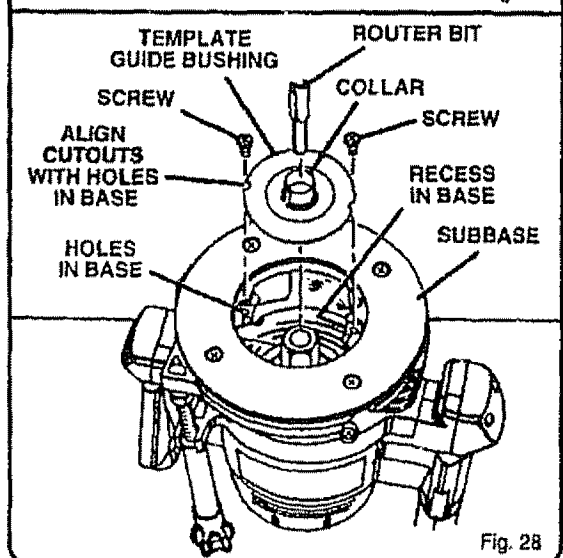
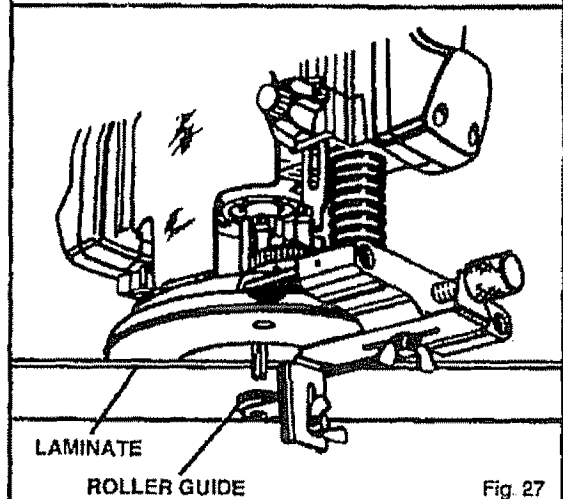
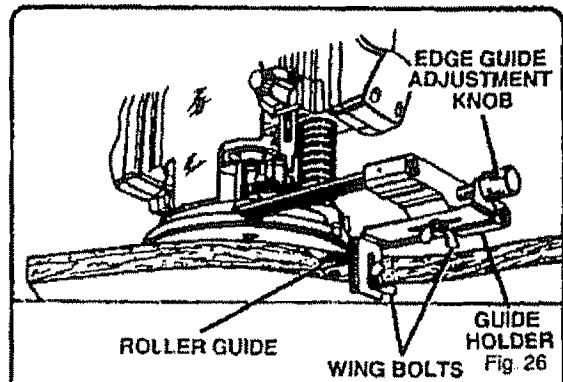

OPERATION

ROUTING WITH GUIDE BUSHINGS (Cont'd)

Secure template to the workpiece. Set router to desired depth of cut and turn it on. Place router base on the template with the collar of the guide bushing against the edge of the template. Lower cutter into the workpiece and proceed around template, keeping guide bushing pressed against template edge.

When routing with template guide bushings it is necessary to allow for the size difference between the cutting edge of the cutter and the face of the guide bushing collar. When making templates, always allow for this size difference. See Figure 29.

FREEHAND ROUTING

See Figure 30.

When used freehand, your plunge router becomes a flexible and versatile tool. This flexibility makes it possible to easily rout signs, relief sculptures, etc.

There are two basic techniques for freehand routing:

1. Routing letters, grooves, and patterns into wood.
2. Routing out the background, leaving the letters or pattern raised above the surface as shown in figure 30.

When freehand routing, we suggest the following:

1. Draw or layout the pattern on workpiece.
2. Choose the appropriate cutter. **NOTE:** A core box or V-groove bit is often used for routing letters and engraving objects. Straight bits and ball mills are often used to make relief carvings. Veining bits are used to carve small, intricate details.
3. Rout the pattern in two or more passes. Make the first pass at 25% of the desired depth of cut. This will provide better control as well as being a guide for the next pass.
4. Do not rout deeper than 1/8 in per pass or cut.

Freehand routing is an excellent example of how to use the plunge routing feature of your router:

1. Choose the appropriate cutter, set desired depth of cut. carefully check set-up, and secure workpiece.
2. Make a test cut in a scrap piece of wood from the same workpiece if possible.
3. Depress plunge release actuator and raise cutter from any preset depth of cut. This also permits raising cutter inside router subbase.
4. Place router on workpiece inside pattern to be routed.
5. Grasp handles securely and depress "on-off" trigger to start your router.
6. Let motor build to full speed, then gradually plunge cutter into workpiece until stop bar comes into contact with stop screw on depth stop block.
7. Squeeze plunge lock actuator to secure depth of cut setting.
8. Begin routing out the pattern, continuing until a complete pass at this depth of cut has been made.

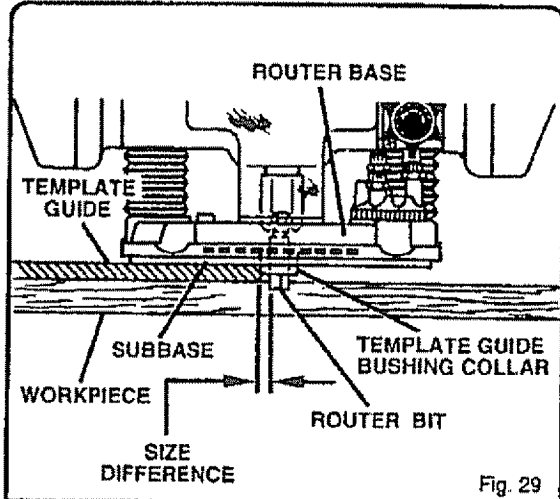

Fig. 29

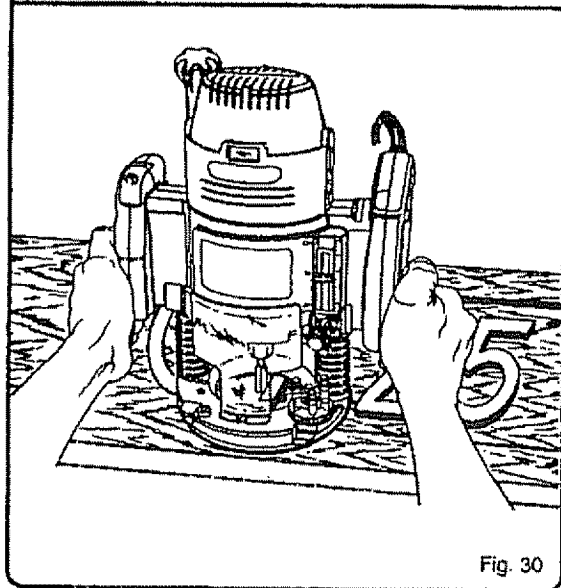

Fig. 30

9. Several cuts that require repositioning of router may be needed for a particular job. If this situation exists, depress plunge release actuator and raise cutter inside router subbase after each cut, reposition router for next cut, gradually plunge cutter into workpiece until stop bar contacts stop screw, squeeze plunge lock actuator and continue routing.
10. After all cuts have been made, depress plunge release actuator, raise cutter inside router subbase, remove router from workpiece, release "on-off" trigger, and allow cutter to come to a complete stop.

MAINTENANCE

WARNING WHEN SERVICING USE ONLY IDENTICAL CRAFTSMAN REPLACEMENT PARTS. USE OF ANY OTHER PARTS MAY CREATE A HAZARD OR CAUSE PRODUCT DAMAGE.

GENERAL

Only the parts shown on parts list, page 23, are intended to be repaired or replaced by the customer. All other parts represent an important part of the double insulation system and should be serviced only by a qualified Sears service technician.

Avoid using solvents when cleaning plastic parts. Most plastics are susceptible to various types of commercial solvents and may be damaged by their use. Use clean cloths to remove dirt, carbon dust, etc.

WARNING: DO NOT AT ANY TIME LET BRAKE FLUIDS, GASOLINE, PETROLEUM-BASED PRODUCTS, PENETRATING OILS ETC. COME IN CONTACT WITH PLASTIC PARTS. THEY CONTAIN CHEMICALS THAT CAN DAMAGE, WEAKEN, OR DESTROY PLASTIC.

PROPER CARE OF CUTTERS

Get faster more accurate cutting results by keeping cutters clean and sharp. Remove all accumulated pitch and gum from cutters after each use.

When sharpening cutters, sharpen only the inside of the cutting edge. Never grind the outside diameter. Be sure when sharpening the end of a cutter to grind the clearance angle the same as originally ground.

BRUSH REPLACEMENT

See Figure 31.

Your router has externally accessible brush assemblies that should periodically be checked for wear.

PROCEED AS FOLLOWS WHEN REPLACEMENT IS REQUIRED:

1. UNPLUG YOUR ROUTER.

WARNING: FAIL TO UNPLUG YOUR ROUTER COULD RESULT IN ACCIDENTAL STARTING CAUSING SERIOUS INJURY.

2. Remove brush cap with a screwdriver. Brush assembly is spring loaded and will pop out when you remove brush cap.
3. Remove brush assembly (brush and spring).
4. Check for wear. If worn, always replace in pairs. Do not replace one side without replacing the other.
5. Reassemble using new brush assemblies. Make sure curvature of brush matches curvature of motor and that brush moves freely in brush tube.
6. Replace brush cap and tighten securely.

When electric tools are used on fiberglass boats, sports cars, wallboard, spackling compounds, or plaster, it has been found that they are subject to accelerated wear and possible premature failure, as the fiberglass chips and grindings are highly abrasive to bearings, brushes, commutator, etc. Consequently, it is not recommended that this tool be used for extended work on any fiberglass material, wallboard, spackling compounds, or plaster. During any use on fiberglass it is extremely important that the tool be cleaned frequently by blowing with an air jet.

WARNING: ALWAYS WEAR SAFETY GOGGLES OR SAFETY GLASSES WITH SIDE SHIELDS DURING POWER TOOL OPERATION OR WHEN BLOWING DUST. IF OPERATION IS DUSTY ALSO WEAR A DUST MASK.

PROPER CARE OF COLLET

From time to time, it also becomes necessary to clean your collet and collet nut. To do so, simply remove collet nut from collet and clean the dust and chips that have collected. Then return collet nut to its original position.

LUBRICATION

All of the bearings in this tool are lubricated with a sufficient amount of high grade lubricant for the life of the unit under normal operating conditions. Therefore, no further lubrication is required.

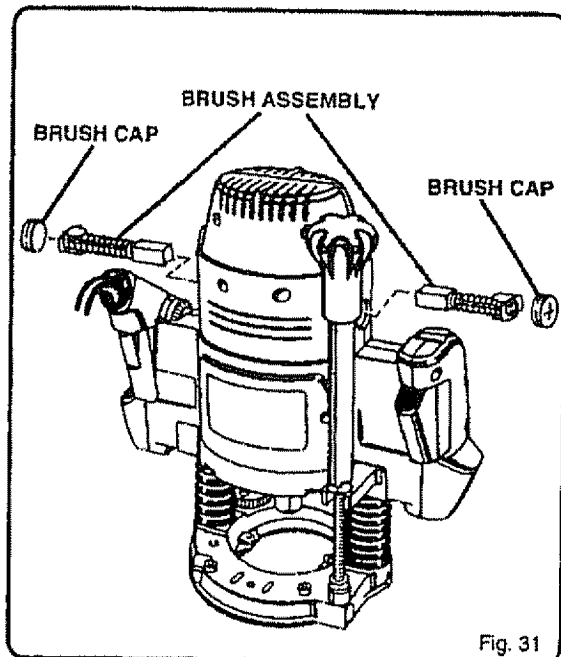

Fig. 31

MAINTENANCE

PLUNGE LOCK ACTUATOR ADJUSTMENTS

See Figure 32.

The plunge lock actuator has been properly set at the factory and no initial adjustments should be required. However, after extended use slight readjustment may be required. If this situation occurs, make adjustments as follows:

1. UNPLUG YOUR ROUTER.

WARNING: FAILURE TO UNPLUG YOUR ROUTER COULD RESULT IN ACCIDENTAL STARTING CAUSING SERIOUS INJURY.

2. Remove lock handle cover screws and lock handle cover. See Figure 32.
3. **NOTE THE LOCATION OF PLUNGE RELEASE ACTUATOR AND COMPRESSION SPRING IN HANDLE.** Reassembly of all parts removed must be identical in order for plunge lock and plunge release actuators to function properly.
4. Loosen hex nut on bottom of plunge lock actuator with a 7/16 in. open end wrench.
5. Loosen socket head screw with a 1/8 in. hex key (allen wrench). This step is needed to make sure screw is not making contact with rod in base assembly.
6. Depress plunge lock actuator until it is flush with handle as shown in figure 33.
7. Continue to hold plunge lock actuator flush with handle, then turn hex key clockwise until socket head screw touches base assembly rod. **IMPORTANT: Do not overtighten screw.**
8. Make sure hex nut remains loose while tightening socket head screw
9. Once socket head screw touches base assembly rod, secure it by tightening hex nut against plunge lock actuator
10. Do not let socket head screw slip or turn while tightening hex nut.
11. Slip compression spring over peg on plunge release actuator. Then locate tabs on actuator in slide grooves. Make sure that end of compression spring rests against wall of stop pocket.
12. Carefully replace handle cover and handle cover screws. Make sure plunge release actuator and compression spring are properly seated.
13. Tighten handle cover screws securely

When properly adjusted, plunge lock actuator will make contact with base assembly rod when it is flush with handle. By squeezing plunge lock actuator past this point, a friction lock situation occurs. This is what locks your router at desired depth of cut settings.

The plunge release actuator is spring loaded. When engaged, it pushes the plunge lock actuator past the flush point in the opposite direction. This loosens socket head screw, releasing pressure from rod in base assembly.

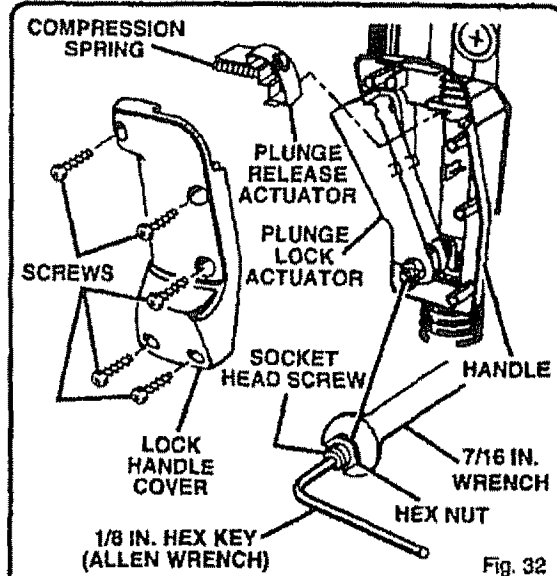

Fig. 32

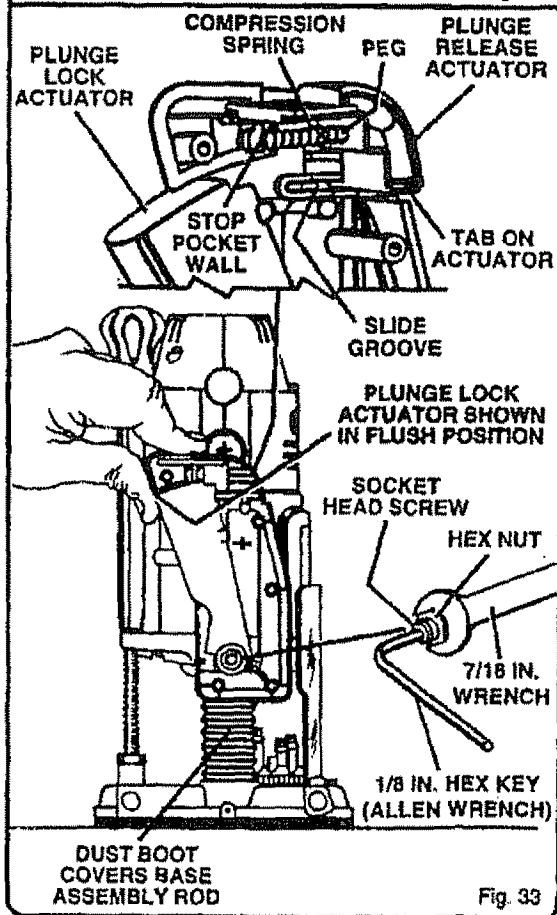

Fig. 33

MAINTENANCE

DEPTH CONTROL KNOB ADJUSTMENTS

See Figure 34.

The depth control knob is spring loaded against hex nut to prevent router motor from accidentally separating from router base. If depth control knob is turned too far up depth adjustment rod, the spring will cause depth control knob to pop off before hex nut. **Do not remove hex nut.** It should remain on depth adjustment rod at all times. This is especially important when using router upside down on a router table.

TO REPLACE DEPTH CONTROL KNOB:

1. UNPLUG YOUR ROUTER.

WARNING: FAILURE TO UNPLUG YOUR ROUTER COULD RESULT IN ACCIDENTAL STARTING CAUSING SERIOUS INJURY.

2. Turn hex nut counterclockwise until 1/4 in. of threads are remaining at the top of depth adjustment rod.
3. Place compression spring on top of hex nut as shown in figure 34.
4. Place depth control knob on top of compression spring and align tabs on depth control knob with flats on hex nut.
5. Carefully compress spring by pushing down on top of depth control knob
6. With spring compressed, thread depth control knob clockwise onto depth adjustment rod.
7. Turn depth control knob until desired depth of cut is reached.

Do not replace depth control knob without compression spring

WARNING: REPLACING DEPTH CONTROL KNOB WITHOUT COMPRESSION SPRING COULD RESULT IN DEPTH CONTROL KNOB AND HEX NUT VIBRATING OFF DEPTH ADJUSTMENT ROD DURING USE. THIS SITUATION COULD CAUSE MOTOR TO SEPARATE FROM ROUTER BASE. BEING TRIP IN POSSIBLE SERIOUS PERSONAL INJURY.

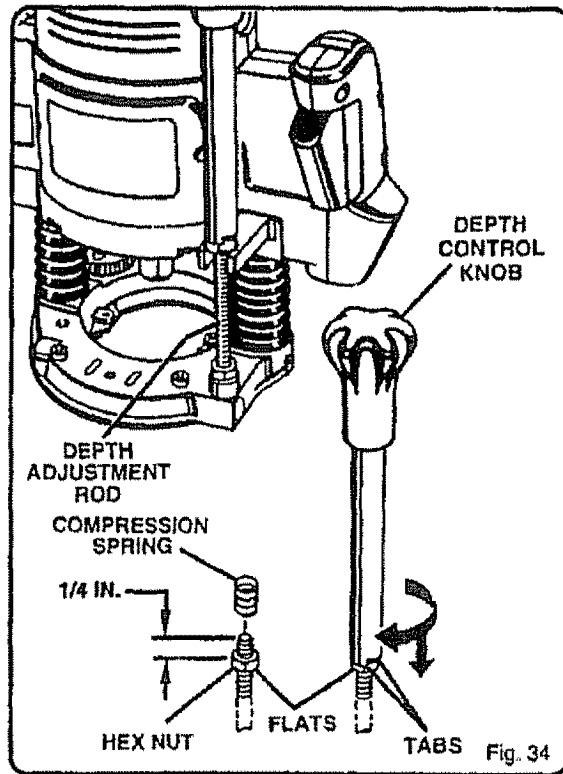

WARNING: DO NOT USE LARGE ROUTER BITS FOR FREEHAND ROUTING. USE OF LARGE ROUTER BITS WHEN FREEHAND ROUTING COULD CAUSE LOSS OF CONTROL OR CREATE OTHER HAZARDOUS CONDITIONS THAT COULD CAUSE POSSIBLE SERIOUS PERSONAL INJURY. WHEN USING A ROUTER TABLE, LARGE ROUTER BITS SHOULD BE USED FOR EDGING ONLY.

EXTENSION CORDS

The use of any extension cord will cause some loss of power. To keep the loss to a minimum and to prevent tool overheating, follow the recommended cord sizes on the chart at the right. When tool is used outdoors, use only extension cords suitable for outdoor use and so marked. Extension cords are available at Sears Retail Stores.

Extension Cord Length	Wire Size A.W.G.
0-25 Feet	14
25-50 Feet	12

WARNING: CHECK EXTENSION CORDS BEFORE EACH USE. IF DAMAGED, REPLACE IMMEDIATELY. NEVER USE TOOL WITH A DAMAGED CORD SINCE TOUCHING THE DAMAGED AREA COULD CAUSE ELECTRICAL SHOCK RESULTING IN SERIOUS INJURY.

HELPFUL HINTS

- ✓ Always clamp workpiece securely before routing.
- ✓ A safe operator is one who thinks ahead.
- ✓ Always wear eye protection when routing.
- ✓ Make set-up adjustments carefully. Then double check. Measure twice and cut once.
- ✓ Keep cutters clean and properly sharpened.
- ✓ Don't let familiarity make you careless.
- ✓ Study all safety rules and do the job safely.
- ✓ **NEVER** place your hands in jeopardy.
- ✓ Make certain clamps can't loosen while in use.
- ✓ Test difficult set-ups on scrap—Don't waste lumber.
- ✓ Plan each operation before you begin.
- ✓ Provide for smoother operation by cleaning your router frequently. Shake router or blow with an air jet to remove sawdust build-up.
- ✓ **THINK SAFETY BY THINKING AHEAD.**

ROUTER TABLES

WARNING: DO NOT USE WITH ROUTER TABLES THAT FAIL TO CONFORM TO SAFE WOOD WORKING PRACTICES AND OFFER PROPER GUARDING FOR THE CUTTER. FAILURE TO COMPLY CAN RESULT IN AN ACCIDENT CAUSING POSSIBLE SERIOUS INJURY.

If mounting your router to a router table, use only the three 5/16-18 UNC-2B tapped holes provided in the router base. Use 5/16-18 UNC-2A flat head screws that are 1-1/8 in. or 1-1/4 in. long if mounting router to a router table. **NOTE:** Router subbase must be removed in order to gain access to the 5/16-18 UNC tapped holes.

WARNING: DO NOT USE THE FOUR 8-32 UNC-2B SUBBASE SCREWS OR THE 8-32 UNC-2B TAPPED SUBBASE SCREW HOLES FOR MOUNTING ROUTER TO A ROUTER TABLE. THESE SCREWS AND SCREW HOLES WILL NOT SECURE ROUTER TO ROUTER TABLE PROPERLY AND COULD RESULT IN AN ACCIDENT CAUSING POSSIBLE SERIOUS INJURY.

The use of Craftsman routers in router tables offered by other manufacturers has not been investigated for compliance with applicable safety standards.

SEE NOTE "A"

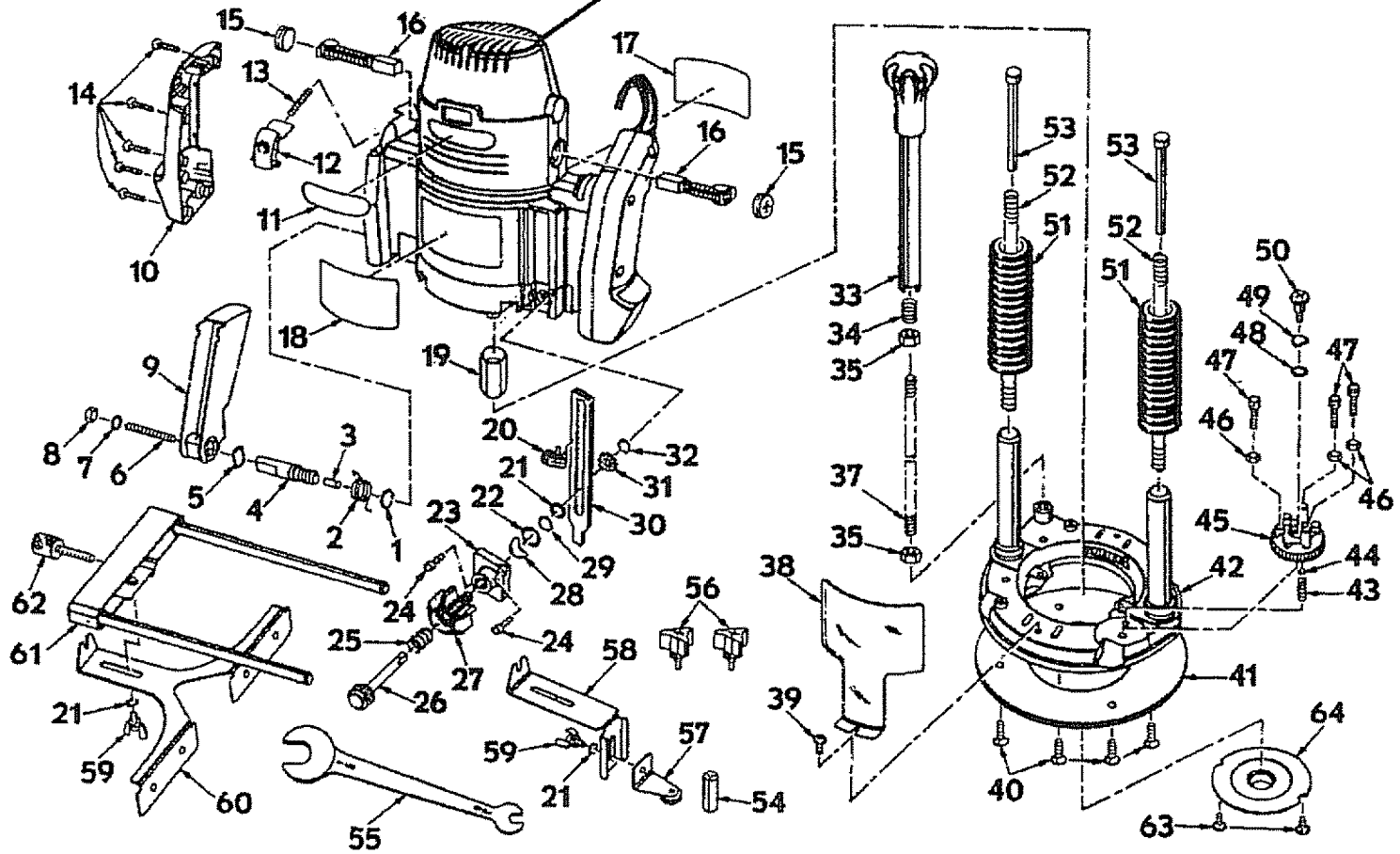

NOTE: "A" - The assembly shown represents an important part of the Double Insulated System. To avoid the possibility of alteration or damage to the system, service should be performed by your nearest Sears Repair Center. Contact your nearest Sears Retail Store.



CRAFTSMAN ROUTER - MODEL NUMBER 315.275062

The model number will be found on a plate attached to the motor housing. Always mention the model number in all correspondence regarding your ROUTER or when ordering repair parts. SEE BACK PAGE FOR PARTS ORDERING INSTRUCTIONS

PARTS LIST

Key No.	Part Number	Description	Quan.	Key No.	Part Number	Description	Quan.
1	622167-028	Retaining Ring.....	1	40	622163-042	* Screw (#8-32 x 3/8 In. Flat Hd.)	
2	970738-002	Torsion Spring.....	1			**STD510803	4
3	970742-001	Stop Plug.....	1	41	970865-001	Subbase	1
4	970709-001	Clamp Bolt	1	42	970755-203	Base Assembly	1
5	970743-001	Keyed Washer	1	43	970772-001	Compression Spring	1
6	970740-001	* Screw (#1/4-28 x 1-5/8 In. Hex Soc. Hd.)	1	44	967711-000	1/4 In. Steel Ball.....	1
7	931744-006	Washer **STD551225.....	1	45	970722-005	Depth Stop Block (Turret).....	1
8	622171-055	* Hex Nut (#1/4-28)	1	46	705404-801	* Hex Nut (#10-24)	3
9	970760-001	Lock Actuator	1	47	940021-006	* Screw (#10-24 x 1/2 In. Cap Soc. Hd.).....	3
10	970758-001	Lock Handle Cover	1	48	706239-830	Washer.....	1
11	971094-001	Posilock Label.....	1	49	622347-019	Spring Washer	1
12	970762-001	Release Actuator	1	50	970712-001	Shoulder Screw.....	1
13	970736-001	Compression Spring	1	51	970741-001	Dust Boot	2
14	617066-030	* Screw (#8-10 x 5/8 In. Pan Hd.)	5	52	970754-001	Compression Spring	2
15	970764-001	Brush Cap	2	53	970723-001	Guide Pin	2
16	970875-001	Brush Assembly.....	2	54	969361-001	1/4 In. Adapter	1
17	974044-001	Data Plate	1	55	971121-001	Combination Wrench (3/8 In. - 7/8 In.)	1
18	970752-001	Logo Plate	1	56	970729-001	Knob Screw.....	2
19	972564-002	1/2 In. Collet Nut	1	57	971705-001	Roller Guide	1
20	970770-001	Zero Reset Indicator	1	58	971706-001	Slide Plate	1
21	931744-063	Washer.....	3	59	971308-001	Wing Bolt.....	2
22	703493-820	Washer.....	1	60	969355-001	Edge Guide	1
23	970720-202	Retainer Plate	1	61	971311-001	Guide Holder	1
24	622931-008	* Screw (#6-32 x 3/8 In. Fil. Hd.)	2	62	971309-001	Edge Guide Adjustment Knob	1
25	970734-001	Compression Spring	1	63	606066-006	* Screw (#10-32 x 3/8 In. Pan Hd.)	2
26	970717-002	Adjustment Knob.....	1	64	971306-001	Guide Bushing.....	1
27	970715-002	Lock Knob	1	65	622167-071	Retaining Ring.....	4
28	622347-017	Spring Washer	1	66	060721-630	*** Guide Bushing w/Nut (1/4 In. x 5/16 In.)	1
29	622167-070	Retaining Ring.....	1	67	060721-530	*** Guide Bushing w/Nut (1/4 In. x 3/8 In.)	1
30	970718-002	Depth Stop Bar.....	1	68	060721-430	*** Guide Bushing w/Nut (1/2 In. x 5/8 In.)	1
31	970719-001	Stop Bar Pinion	1	69	060721-030	*** Guide Bushing w/Nut (11/32 In. x 7/16 In.)	1
32	989177-000	Retaining Ring.....	1	70	972160-001	*** Guide Bushing Adapter	1
33	970866-002	Depth Control Knob.....	1	71	969359-001	*** 3/8 In. Adapter	1
34	971137-001	Compression Spring	1	72	969357-002	*** Optional Roller Guide Assembly (Includes Key Nos. 21, 57, 58, & 59)	1
35	607406-005	* Hex Nut (#3/8-16)	2			*** Optional Guide Holder w/Hardware (Includes Key Nos. 21, 56, 59, 60, 61 & 62)	1
37	970732-001	Depth Adjustment Rod	1	73	972421-000	Owner's Manual	
38	970864-001	Chip Shield.....	1				
39	614658-010	* Screw (#8-32 x 3/8 In. Pan Hd.)	1				
		**STD510803	1				

* Standard Hardware Item — May Be Purchased Locally

** Available From Div.98 — Source 980.00

*** Optional Accessory (Not Shown) — May Be Purchased For Use On Your New Plunge Router

SEARS

OWNER'S
MANUAL

SERVICE

MODEL NO.
315.275062

HOW TO ORDER
REPAIR PARTS

CRAFTSMAN[®]

**Industrial Electronic
Plunge Router
Double Insulated**

Now that you have purchased your router, should a need ever exist for repair parts or service, simply contact any Sears Service Center and most Sears, Roebuck and Co. stores. Be sure to provide all pertinent facts when you call or visit.

The model number of your router will be found on a plate attached to the motor housing.

WHEN ORDERING REPAIR PARTS, ALWAYS GIVE THE FOLLOWING INFORMATION:

- | | |
|------------------------------|--|
| • PART NUMBER | • PART DESCRIPTION |
| • MODEL NUMBER
315.275062 | • NAME OF ITEM
Industrial Electronic
Plunge Router |

All parts listed may be ordered from any Sears Service Center and most Sears stores.

If the parts you need are not stocked locally, your order will be electronically transmitted to a Sears Repair Parts Distribution Center for handling.