

Model No. WESY5993

Serial No. _____

Write the serial number in the space above for future reference.

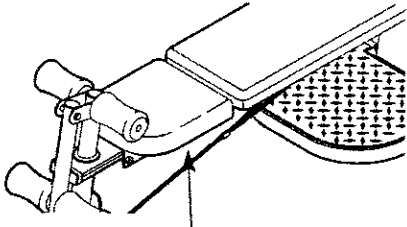

Serial Number Decal (under seat)

QUESTIONS?

As a manufacturer, we are committed to providing complete customer satisfaction. If you have questions, or if a part is damaged or missing, PLEASE CONTACT OUR CUSTOMER SERVICE DEPARTMENT DIRECTLY.

CALL TOLL-FREE:

1-877-992-5999

Mon.–Fri., 6 a.m.–6 p.m. MST

ON THE WEB:

www.weiderservice.com

▲ CAUTION

Read all precautions and instructions in this manual before using this equipment. Save this manual for future reference.

MAX

by WEIDER™

LEGEND

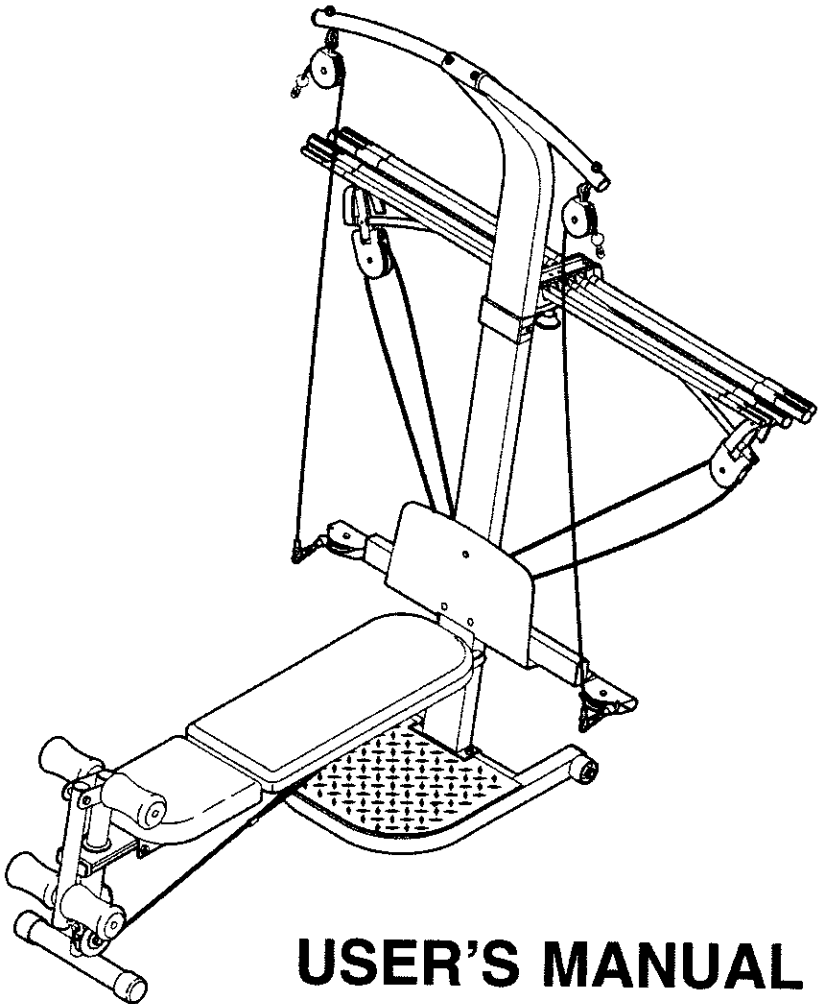

USER'S MANUAL



Visit our website at

www.weiderfitness.com

new products, prizes,
fitness tips, and much more!

TABLE OF CONTENTS

WARNING DECAL PLACEMENT	2
IMPORTANT PRECAUTIONS	3
BEFORE YOU BEGIN	4
ASSEMBLY	5
ADJUSTMENTS	13
CABLE DIAGRAM	16
EXERCISE GUIDELINES	17
ORDERING REPLACEMENT PARTS	Back Cover
LIMITED WARRANTY	Back Cover

Note: A PART IDENTIFICATION CHART and a PART LIST/EXPLODED DRAWING are attached in the center of this manual. Remove the PART IDENTIFICATION CHART and PART LIST/EXPLODED DRAWING before beginning assembly.

WARNING DECAL PLACEMENT

The decals shown here have been placed on the resistance system. If a decal is missing or illegible, call the toll-free telephone number on the front cover of this manual and order a free replacement decal. Apply the decal in the location shown.

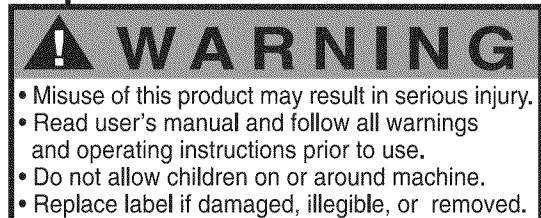
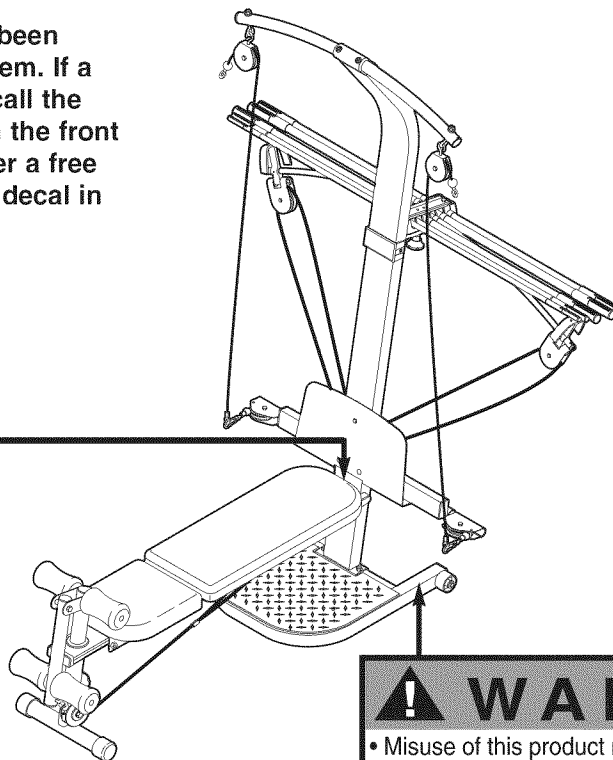
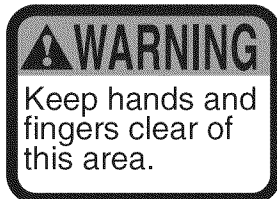

IMPORTANT PRECAUTIONS

⚠ WARNING: To reduce the risk of serious injury, read the following important precautions before using the resistance system.

1. Read all instructions in this manual and all warnings on the resistance system before using the resistance system. Use the resistance system only as described in this manual.
2. It is the responsibility of the owner to ensure that all users of the resistance system are adequately informed of all precautions.
3. The resistance system is intended for home use only. Do not use the resistance system in any commercial, rental, or institutional setting.
4. Keep the resistance system indoors, away from moisture and dust. Place the resistance system on a level surface, with a mat beneath it to protect the floor or carpet. Make sure that there is enough clearance around the resistance system to mount, dismount, and use the resistance system.
5. Inspect and properly tighten all parts regularly. Replace any worn parts immediately.
6. Keep children under 12 and pets away from the resistance system at all times.
7. Keep hands and feet away from moving parts.
8. Always wear athletic shoes for foot protection while exercising.
9. The top frame is not designed to be used for pull-up exercises. Do not hang on the top frame.
10. The resistance system is designed to support a maximum user weight of 300 pounds.
11. The resistance system is designed to be used with the included resistance, and the MAX PACK. Do not use the resistance system with any other type of resistance.
12. When adding resistance, both ends of the resistance bars must rest under the two “U”-channels. Add and remove resistance bars from the “U”-channels one resistance bar at a time.
13. Keep clear of the area around the “U”-channels while the resistance system is in use. Do not add or remove resistance bars from the “U”-channels while the end of the long cable is pulled out.
14. Always adjust the resistance bar assembly to the horizontal position and make sure the fulcrum knob is secure before using the resistance system.
15. Make sure the rings on the resistance bars are pushed against the tray before using the resistance system.
16. If you purchase the optional lat bar, always disconnect it from the short cables when performing an exercise that does not require it.
17. Make sure the storage knob is in place and fully tightened each time the resistance system is used.
18. Pull on the low pulley cable only while sitting on the bench or standing on the base plate. Pull on the high pulley cables only while sitting on the bench, with the seat in one of the three positions closest to the upright base, or while standing on the base plate.
19. Make sure that the cables remain on the pulleys at all times. If the cables bind as you are exercising, stop immediately and make sure that the cables are on the pulleys. Replace all cables at least every two years.
20. If you feel pain or dizziness while exercising, stop immediately and begin cooling down.

⚠ WARNING: Before beginning this or any exercise program, consult your physician. This is especially important for persons over the age of 35 or persons with pre-existing health problems. Read all instructions before using. ICON assumes no responsibility for personal injury or property damage sustained by or through the use of this product.

BEFORE YOU BEGIN

Thank you for selecting the innovative MAX by WEIDER™ LEGEND resistance system. The resistance system offers a selection of stations designed to develop every major muscle group of the body. Whether your goal is to tone your body, build dramatic muscle size and strength, or improve your cardiovascular system, the resistance system will help you to achieve the specific results you want.

For your benefit, read this manual carefully before using the resistance system. If you have questions after reading this manual, see the front cover of this

manual. To help us assist you, please note the product model number and serial number before calling. The model number is WESY5993.3. The serial number can be found on a decal attached to the resistance system (see the front cover of this manual).

To avoid a registration fee for any service needed under warranty, you must register the resistance system at www.weiderservice.com/registration.

Before reading further, please review the drawing below and familiarize yourself with the parts that are labeled.

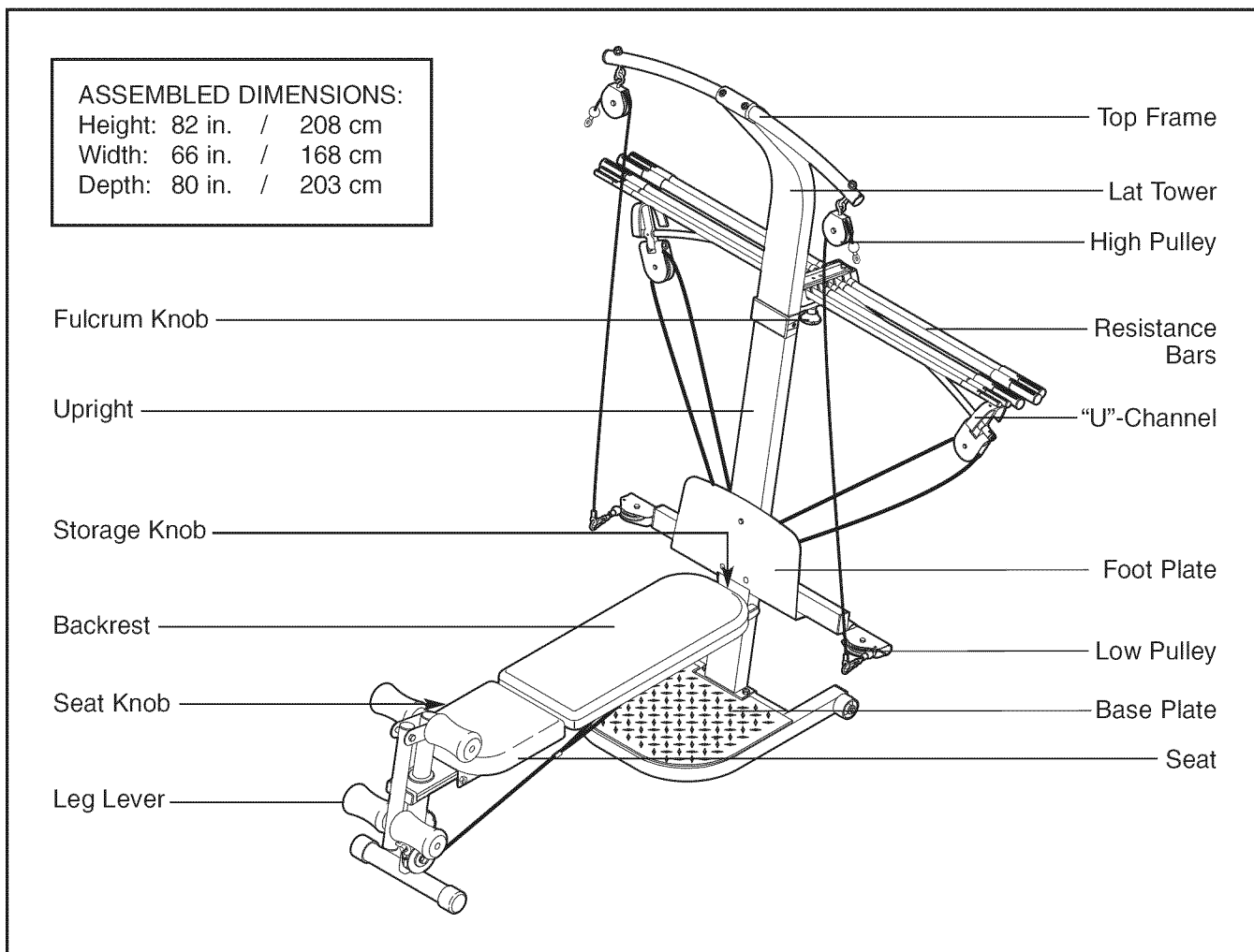

ASSEMBLY

Make Things Easier for Yourself





This manual is designed to ensure that the resistance system can be assembled successfully by most people. However, it is important to realize that the versatile resistance system has many parts and that the assembly process will take time. Most people find that by setting aside plenty of time, assembly will go smoothly.

Before beginning assembly, carefully read the following information and instructions:

- Assembly requires two persons.
- Place all parts in a cleared area and remove the packing materials. Do not dispose of the packing materials until assembly is completed.
- **For help identifying small parts, use the PART IDENTIFICATION CHART.** Note: Some small parts may have been pre-attached for shipping. If a part is not in the parts bag, check to see if it has been pre-attached.

- Tighten all parts as you assemble them, unless instructed to do otherwise.
- As you assemble the resistance system, make sure all parts are oriented as shown in the drawings.

The included Allen wrenches  and the following tools (not included) are required for assembly:

- Two adjustable wrenches 
- One rubber mallet 
- One standard screwdriver 
- One Phillips screwdriver 
- Lubricant, such as grease or petroleum jelly, and soapy water.

Assembly will be more convenient if you have a socket set, a set of open-end or closed-end wrenches, or a set of ratchet wrenches.

1. Before beginning assembly, make sure that you have read and understand the information in the box above.

Press two 50mm Square Inner Caps (98) into the Base (1).

Attach two Plastic Feet (53) and two Large Plastic Feet (102) to the Base (1) with four M4 x 16mm Screws (62).

Attach the Upright (3) to the Base (1) with two M10 x 66mm Carriage Bolts (83), two M10 x 72mm Bolts (64), and four M10 Nylon Locknuts (76) as shown. **Note: This step will be easier to complete if the Upright and Base are tipped on their sides.**

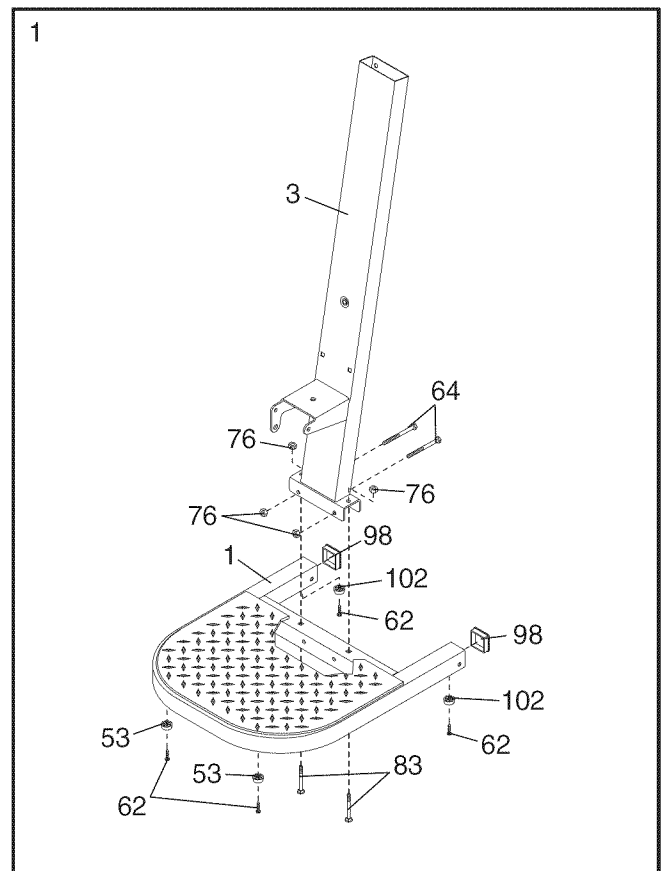

- Attach a Wheel (31) to the outside of the Base (1) with an M10 x 108mm Bolt (81), three M10 Washers (75), and an M10 Nylon Locknut (76). **Do not overtighten the Locknut; the Wheel must be able to turn easily.**

Attach the other Wheel (not shown) in the same manner.

- Press a 38mm x 64mm Inner Cap (41) into each end of the Cross Tube (11).

Orient the Cross Tube (11) as shown, with the welded tubes at the bottom. Attach the Foot Plate (23) and the Cross Tube to the Upright (3) with two M10 x 140mm Carriage Bolts (73), two M10 Washers (75), and two M10 Nuts (47). **Do not insert a bolt into the top hole in the Foot Plate yet.**

- Press two 57mm Round Outer Caps (27) onto the ends of the Front Leg (6).

Orient the Bench Rail (5) as shown. Slide the Rail Bracket (105) into the indicated end of the Bench Rail, and align the holes in the Bracket with the holes in the Bench Rail.

Orient the Front Leg (6) as shown. Attach the Front Leg to the Bench Rail (5) with the Rail Bracket (105), four M8 x 25mm Button Screws (46), and four M8 Split Washers (52).

- See the inset drawing.** Snap the Seat Knob (45) into the Seat Carriage (12) and attach it with two M6 x 16mm Screws (82) and two M6 Black Nylon Locknuts (69). **Make sure the slot in the Knob is aligned with the slot in the Seat Carriage.**

Orient the Seat (13) and Seat Backing (9) as shown. Attach the Seat and Seat Backing to the Seat Carriage (12) with four M6 x 16mm Screws (82).

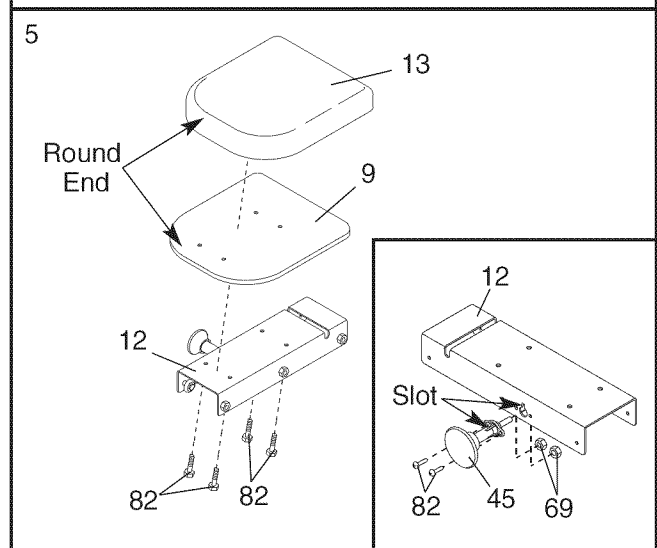
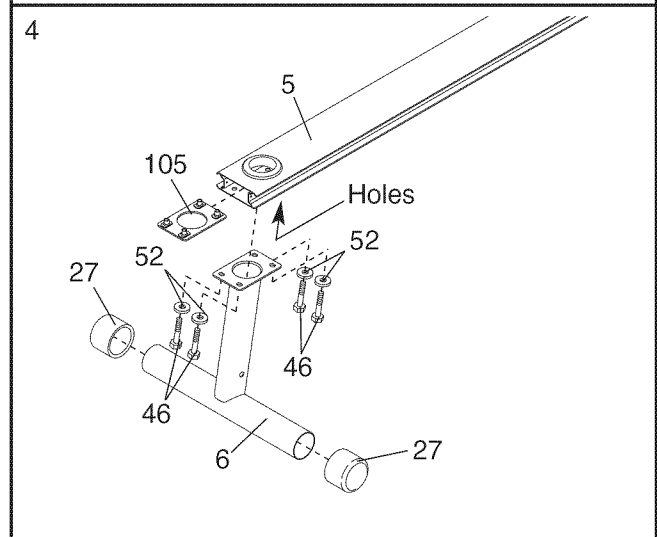
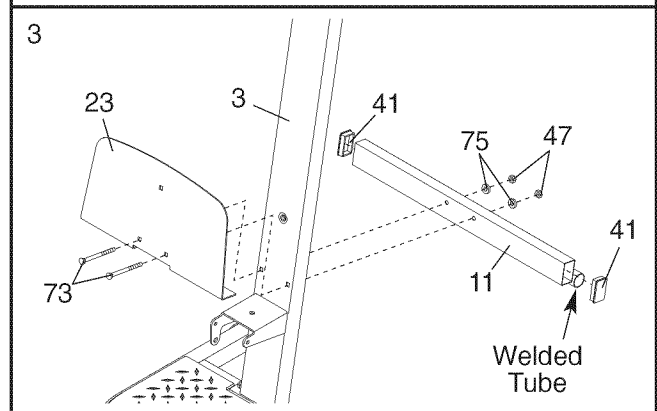
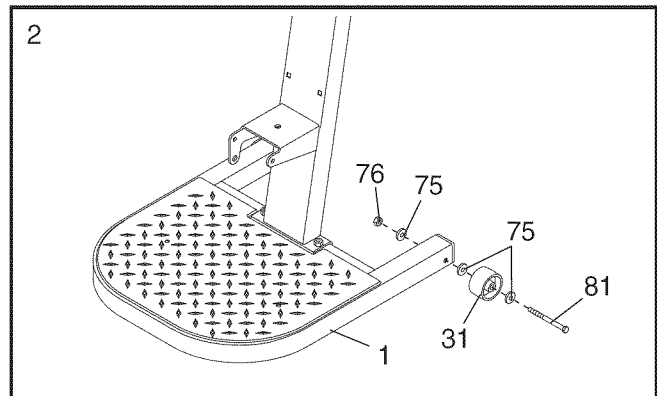

- Pull the Seat Knob (45, not shown) out as far as it will go, and slide the Seat Carriage (12) onto the Bench Rail (5). Engage the Seat Knob into the third hole from the end of the Bench Rail.

See the inset drawing. Attach a Hook (104) to the bottom of the Bench Rail (5).

Press the two Rail Inner Caps (99), with the wide ends on the top or bottom (as indicated), into the ends of the Bench Rail (5). Attach the Caps with four M4 x 16mm Screws (62).

Locate the Leg Lever Cable (32), which has three ends connected in the middle with a bracket. Route the end of the Cable with the eyebolt under a "V"-pulley (92). Attach the "V"-pulley to the Front Leg (6) with an M10 x 107mm Bolt (97) and an M10 Nylon Locknut (76). **Slide the other two ends of the Cable onto the Hook (104).**

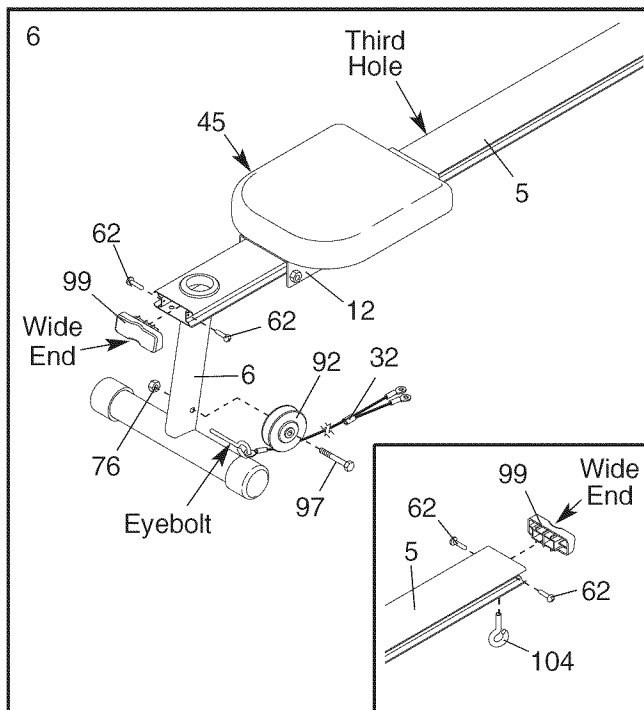

- Attach the Bench Rail (5) to the Upright (3) with an M10 x 132mm Bolt (66), a 19mm Spacer (17), a 22mm Spacer (106), and an M10 Nylon Locknut (76). Fully tighten the Storage Knob (30) into the Upright and Rail.

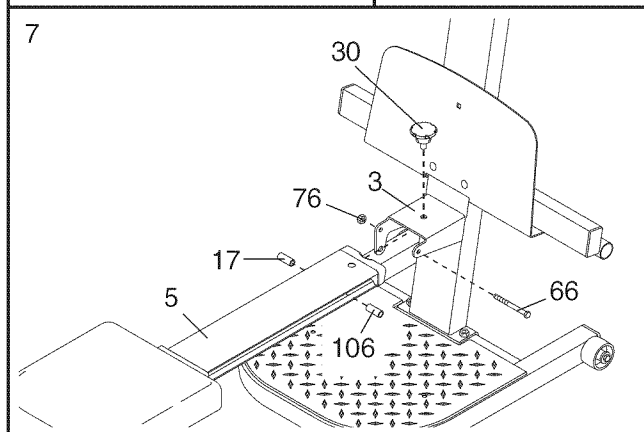

- Attach the Lat Tower (4) to the Upright (3) with four M10 x 25mm Button Head Screws (87) and four M10 Split Washers (103).

Attach the Name Plate (89) to the Lat Tower (4) with two M4 x 16mm Screws (62).

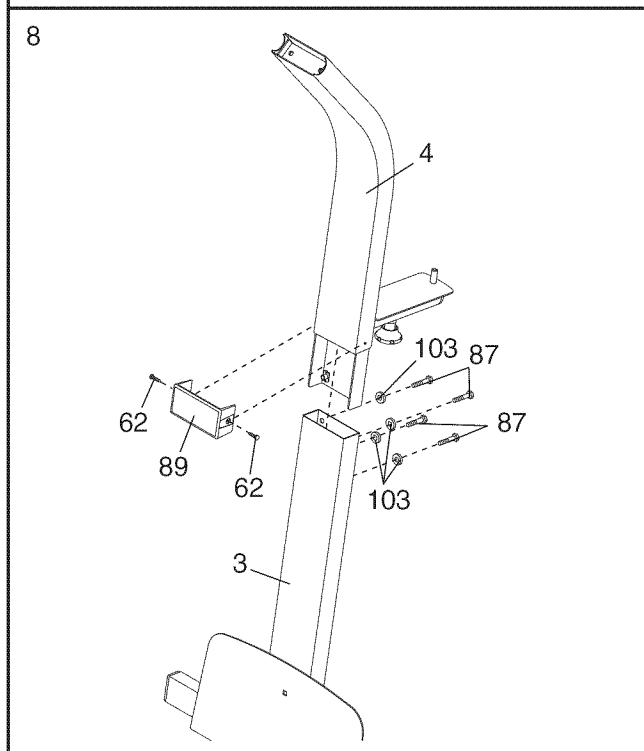

- Press two 38mm Round Inner Caps (38) into the ends of the Top Frame (10).

Attach two Eyebolts (34) to the Top Frame (10) with two M8 Washers (59) and two M8 Nylon Locknuts (65). **Do not overtighten the Locknuts; the Eyebolts must be able to rotate freely.**

Attach the Top Frame (10) to the Lat Tower (4) with two M10 x 65mm Button Head Screws (70), two M10 Washers (75), and the Top Frame Cover (93). **Make sure that the Eyebolts (34) are oriented as shown in the inset drawing. If they are not, turn the Top Frame around and reattach it.**

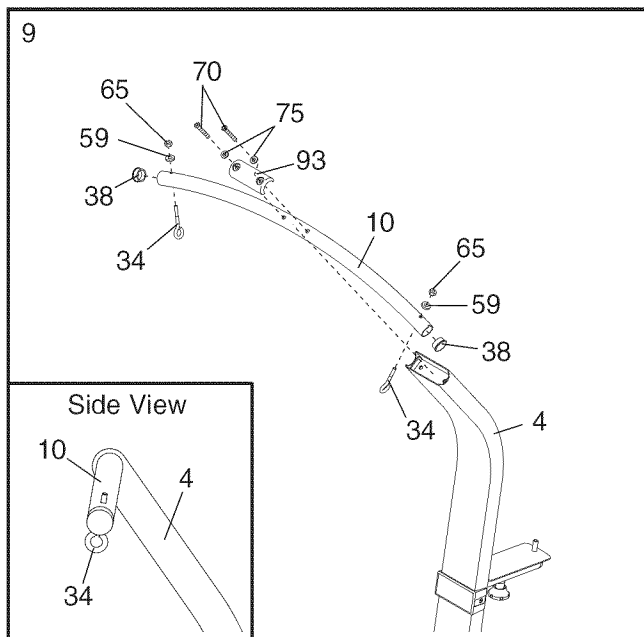

- Attach the two 10-pound Short Caps (20) to the 10-pound Center Resistance Bar (44) with two M4 x 12mm Flat Head Screws (85).

Using ten M4 x 12mm Flat Head Screws (85), attach the two 10-pound Caps (101) to the 10-pound Removable Resistance Bar (67), the two 20-pound Caps (88) to the 20-pound Removable Resistance Bar (36), the four 80-pound Caps (100) to the two 80-pound Resistance Bars (95), and the two 40-pound Caps (79) to the 40-pound Resistance Bar (96).

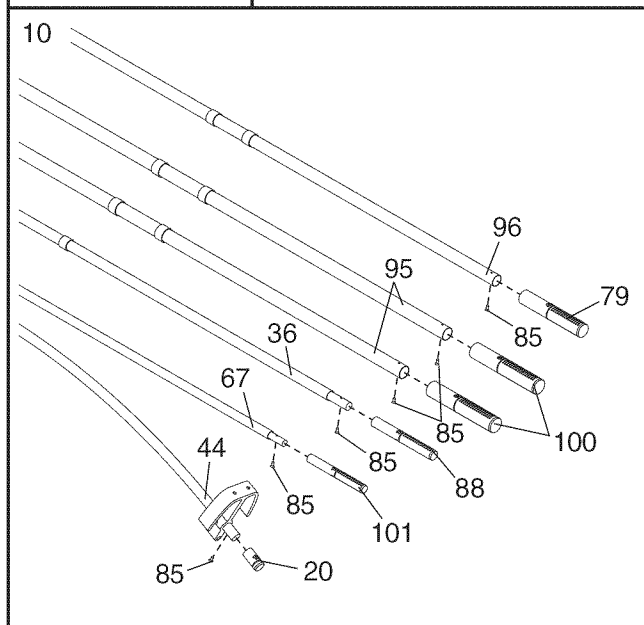

- Locate the Fulcrum (18) on the Lat Tower (4) (see the inset drawing). Slide the Tray (35) onto the rods on the Fulcrum. **Make sure the Tray is oriented as shown in the drawing.**

Set the Resistance Bars into the Tray (35) in the following order: the 10-pound Removable Resistance Bar (67), the 20-pound Removable Resistance Bar (36), an 80-pound Resistance Bar (95), the 10-pound Center Resistance Bar (44), an 80-pound Resistance Bar (95), and the 40-pound Resistance Bar (96). **Make sure the indicated rings are on the side shown and the arrows point toward the Tray.**

Attach the Cover Plate (72), with the edges up, to the Tray (35) with two M8 x 19mm Button Head Screws (86).

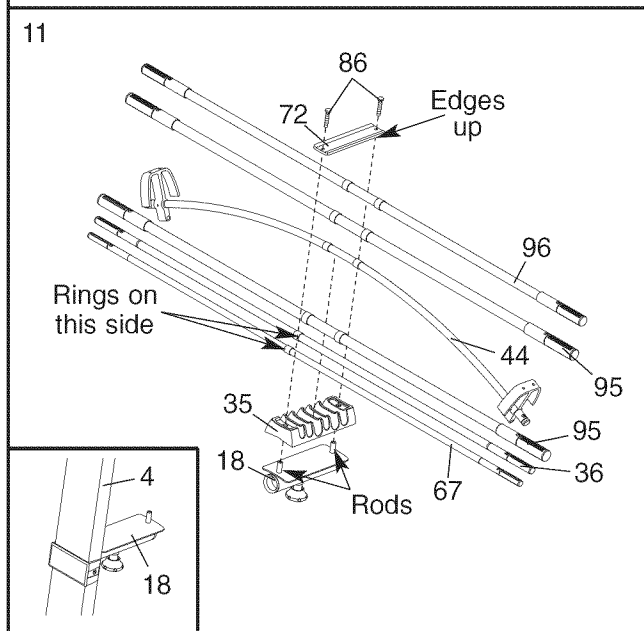

12. Press two 25mm Square Inner Caps (54) into the indicated end of the Backrest Frame (15).

Attach a Plastic Foot (53) to the Backrest Frame (15) with an M4 x 16mm Screw (62).

Orient the Backrest (14) and the Backrest Backing (8) as shown. Attach the Backrest and the Backrest Backing to the Backrest Frame (15) with four M6 x 45mm Screws (58).

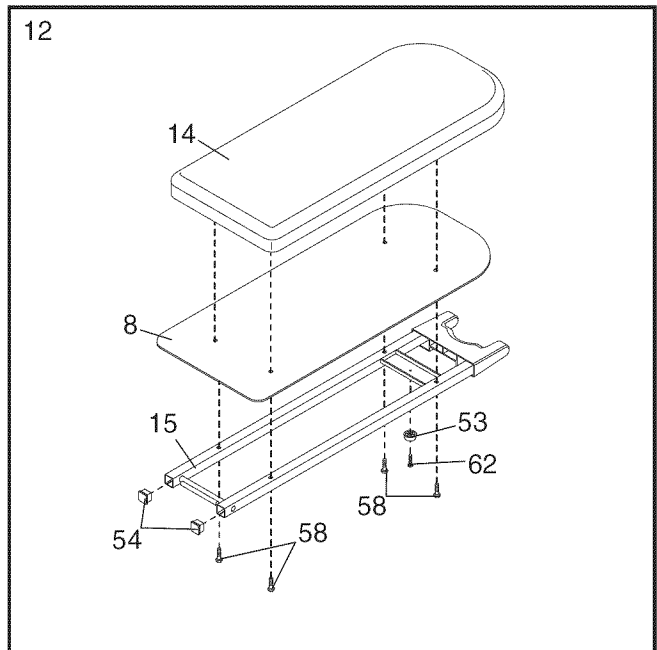

13. Insert the rod on the Backrest Frame (15) into the slot in the Seat Carriage (12). **Hold the Backrest Frame vertically over the Seat Carriage and slide the rod into the slot, as shown in the inset drawing.**

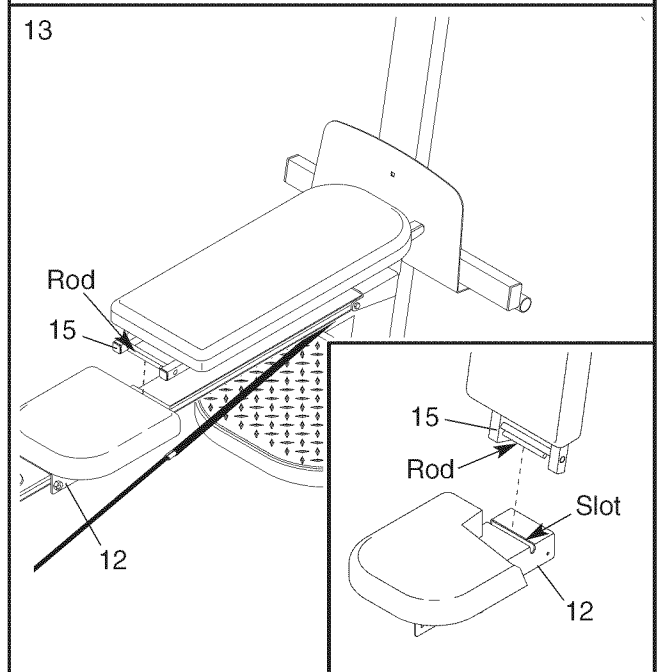

14. Press two 50mm Round Inner Caps (57) into the top and bottom of the Leg Developer (19). Press two 45mm Round Inner Caps (56) into the top and bottom of the Leg Lever (7).

Lubricate an M10 x 69mm Bolt (60) with grease. Attach the Leg Lever (7) to the Leg Developer (19) with the Bolt and an M10 Nylon Locknut (76). **Do not overtighten the Locknut; the Leg Lever must be able to pivot easily.**

Press two 19mm Round Inner Caps (78) into the tube on the Leg Lever (7). Slide two Foam Pads (26) onto the tubes. **Repeat with the tube on the Leg Developer (19).**

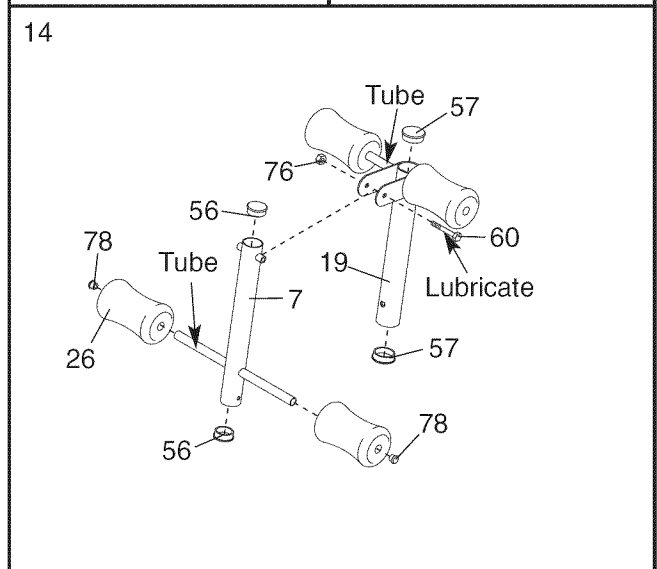

15. Slide the Leg Developer (19) into the Bench Rail (5). Align the hole in the Leg Developer with a hole in the Front Leg (6). Tighten the Bench Knob (42) into the hole in the Leg Developer.

Connect the eyebolt on the Leg Lever Cable (32) to indicated side of the Leg Lever (7) with an M8 Nylon Locknut (65).

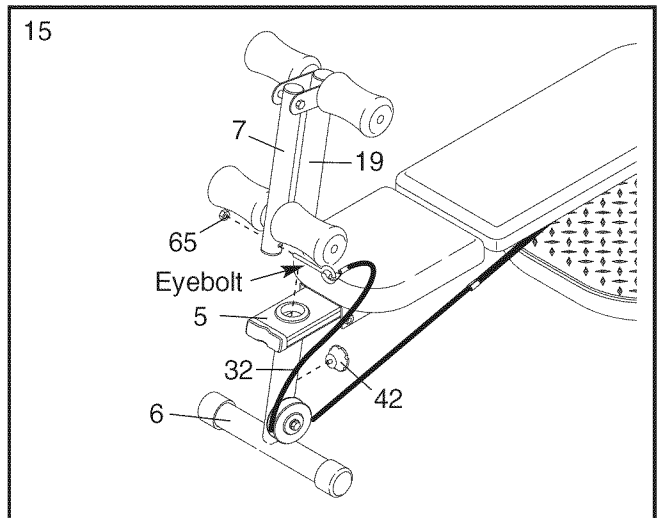

16. **Locate the Long Cable (80).** Insert one end of the Cable through the welded tube on the indicated end of the Cross Tube (11) and then through a Swivel Arm (22). If necessary, use the tip of a screwdriver to pull the end of the Cable out of the Swivel Arm. **Make sure the Cable is on the indicated side of the welded rod in the Swivel Arm.**

Insert the Swivel Arm (22) into the welded tube on the Cross Tube (11). Secure the Swivel Arm with an M4 x 5mm Screw (107).

Wrap the Long Cable (80) around a 90mm Pulley (28). Attach the Pulley inside of the Swivel Arm (22) with an M10 x 42mm Button Head Bolt (71) and an M10 Nylon Locknut (76).

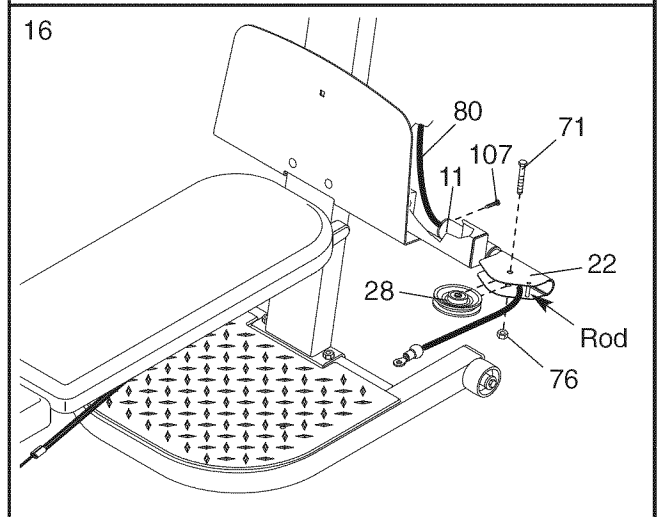

17. Wrap the Long Cable (80) around a 90mm Pulley (28). Attach the Pulley and a Pulley Guard (29) to the indicated M10 x 140mm Carriage Bolt (73) with an M10 Nylon Locknut (76). **Make sure the flat edge of the Pulley Guard is on the side shown.**

18. Attach a Pulley Housing (94) to the indicated "U"-channel on the 10-pound Center Resistance Bar (44) with an M10 x 102mm Button Head Bolt (24), two Pivot Bushings (74), and an M10 Nylon Locknut (76).

Wrap the Long Cable (80) around a 90mm Pulley (28). Attach the Pulley inside of the Pulley Housing (94) with an M10 x 42mm Button Head Bolt (71) and an M10 Nylon Locknut (76).

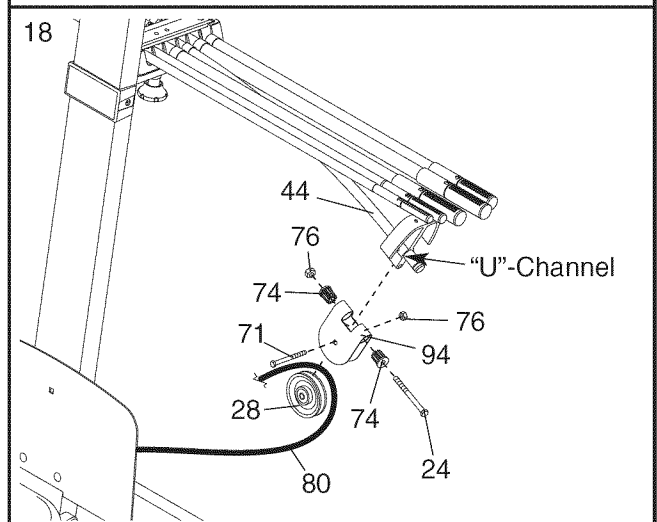
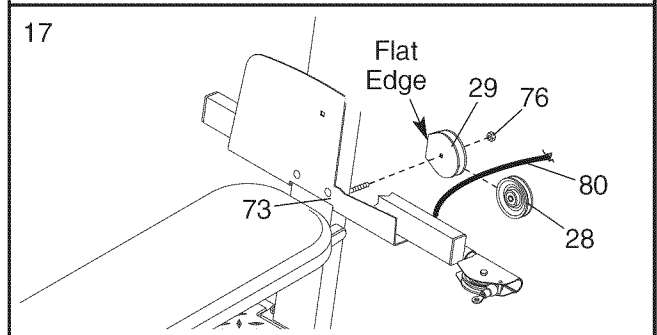

19. Wrap the Long Cable (80) under a 90mm Pulley (28) as shown. Attach the Pulley and a Pulley Guard (29) to the Upright (3) with an M10 x 113mm Button Head Bolt (40) and an M10 Nylon Locknut (76). **Make sure the flat edge of the Pulley Guard is on the bottom.**

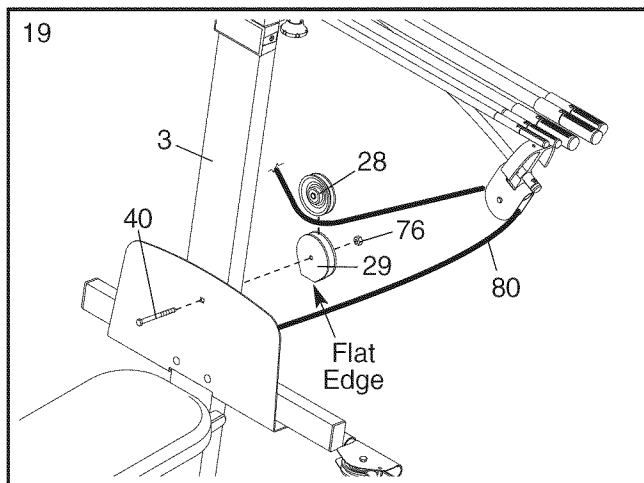

20. Attach a Pulley Housing (94) to the indicated "U"-channel on the 10-pound Center Resistance Bar (44) with an M10 x 102mm Bolt (24), two Pivot Bushings (74), and an M10 Nylon Locknut (76).

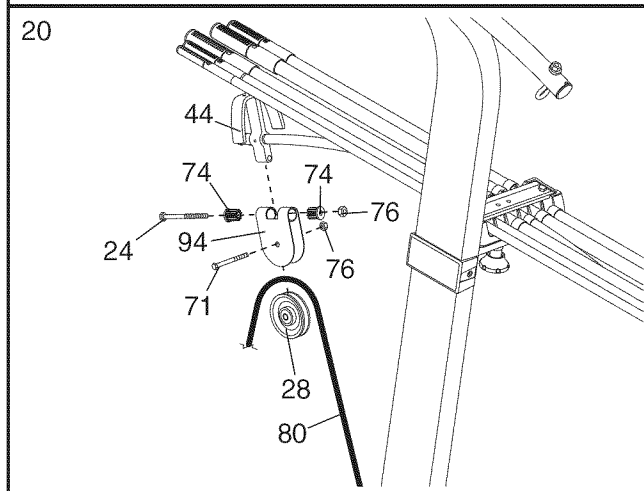

Wrap the Long Cable (80) around a 90mm Pulley (28). Attach the Pulley inside of the Pulley Housing (94) with an M10 x 42mm Button Head Bolt (71) and an M10 Nylon Locknut (76).

21. Wrap the Long Cable (80) around a 90mm Pulley (28). Attach the Pulley and a Pulley Guard (29) to the indicated M10 x 140mm Carriage Bolt (73) with an M10 Nylon Locknut (76). **Make sure the flat edge of the Pulley Guard is on the side shown.**

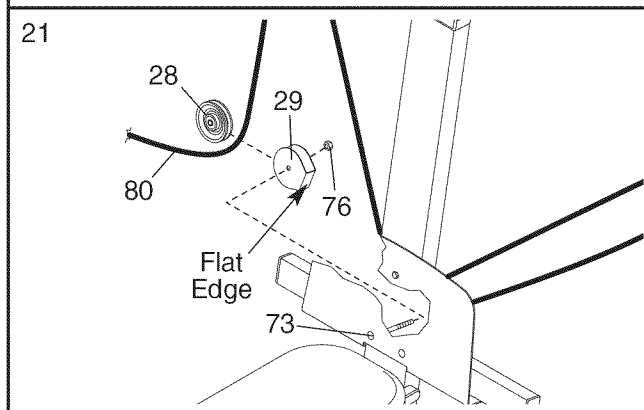

22. Make sure there are no Resistance Bar (not shown) under the "U"-channels on the 10-pound Center Resistance Bar (not shown). Have a second person pull on the Long Cable (80) to create slack in the Cable.

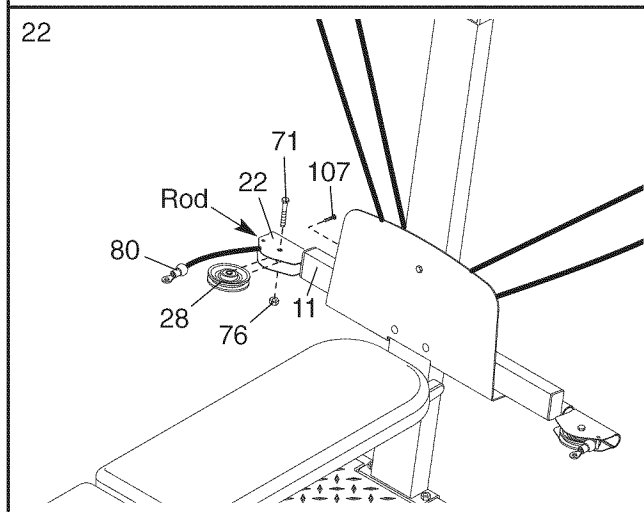

Insert the end of the Long Cable (80) through the welded tube on the indicated end of the Cross Tube (11) and then through the remaining Swivel Arm (22). **Make sure the Cable is on the indicated side of the welded rod in the Swivel Arm.**

Insert the Swivel Arm (22) into the welded tube on the Cross Tube (11). Secure the Swivel Arm with an M4 x 5mm Screw (107).

Wrap the Long Cable (80) around a 90mm Pulley (28). Attach the Pulley inside of the Swivel Arm (22) with an M10 x 42mm Button Head Bolt (71) and an M10 Nylon Locknut (76).

23. **Locate the two Short Cables (33).** Wrap one of the Cables around a 90mm Pulley (28). Attach the Pulley to a High Pulley Housing (21) with an M10 x 42mm Button Head Bolt (71) and an M10 Nylon Locknut (76).

Repeat this step with the other Short Cable (33).

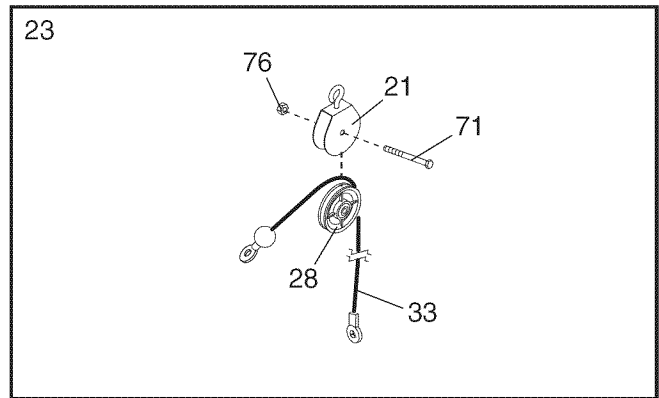

24. Make sure that all parts have been properly tightened. The use of the remaining parts will be explained in ADJUSTMENTS, beginning on the following page.

Before using the resistance system, pull the long cable a few times to be sure that it moves smoothly over the pulleys. If the cable does not move smoothly, find and correct the problem. **IMPORTANT: If the cables are not properly installed, they may be damaged when heavy resistance is used. See the CABLE DIAGRAM on page 16 for proper cable routing.**

ADJUSTMENTS

This section explains how to adjust the resistance system. See the EXERCISE GUIDELINES on page 17 for important information about how to get the most benefit from your exercise program. Also, refer to the accompanying exercise guide to see the correct form for each exercise.

Make sure all parts are properly tightened each time the resistance system is used. Replace worn parts immediately. The resistance system can be cleaned with a damp cloth and a mild, non-abrasive detergent. Do not use solvents. The resistance bars can be cleaned with a vinyl and rubber protectant, available at an automotive or department store.

ATTACHING THE HIGH PULLEYS AND LEG LEVER

To use a high pulley, slide the hook on the High Pulley Housing (21) onto an Eyebolt (34). Attach the end of the Short Cable (33) without the ball to the end of the Long Cable (80) with a Cable Clip (51). **Attach the other high pulley in the same manner.**

To use the Leg Lever (not shown), attach the two ends of the Leg Lever Cable (32) to the ends of the Long Cable (80) with two Cable Clips (51).

Remove the high pulleys, and detach the Leg Lever Cable (32), when not in use. Store the ends of the Leg Lever Cable on the Hook (104) under the Bench Rail (not shown).

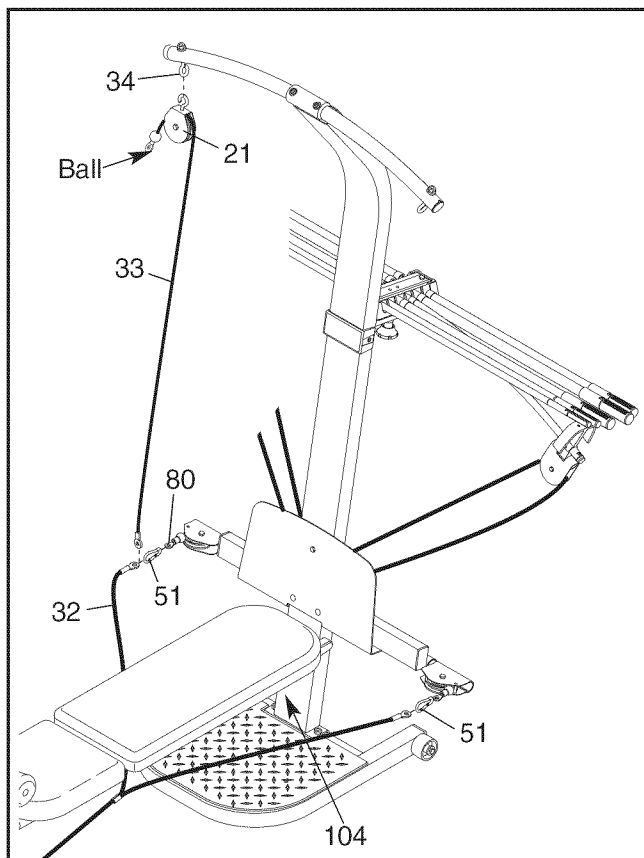

ADJUSTING THE SEAT

The Seat (13) can be secured in any of five positions on the Bench Rail (5). To move the Seat, pull the Seat Knob (45) out as far as it will go, and slide the Seat to the desired position. Engage the Seat Knob into an adjustment hole in the Bench Rail.

To perform row exercises, the leg press strap must be attached to the long cable (see ATTACHING THE ACCESSORIES, on page 14), and the Seat Carriage (12) must be able to roll along the Bench Rail (5). First, remove the Backrest (14) from the Seat Carriage (see ADJUSTING THE BACKREST on page 15). Then, pull the Seat Knob (45) out as far as it will go, and turn the Knob so that the pin rests at the end of the "L"-shaped slot (see the inset drawing).

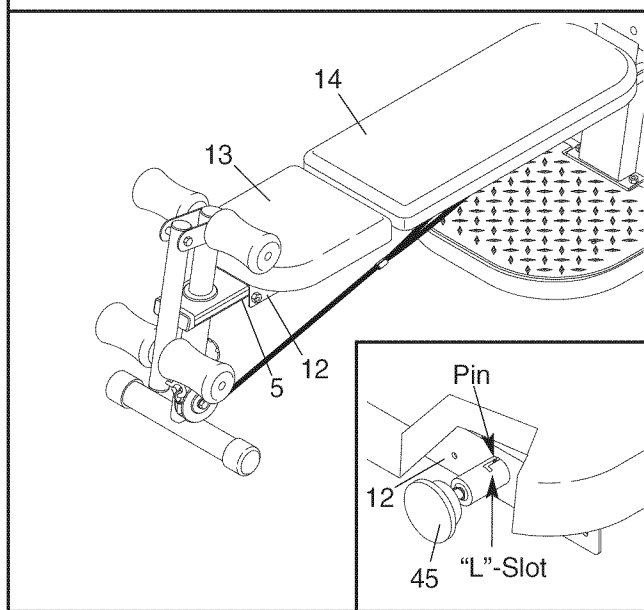

ATTACHING THE ACCESSORIES

To attach a Short Handle (49) to a high pulley, first attach the high pulley to the resistance system (see ATTACHING THE HIGH PULLEYS AND LEG LEVER on page 13). Then, attach the Short Handle to the Short Cable (33) with a Cable Clip (51).

The Long Handles (not shown) and the Ankle Strap (not shown) can be attached to the Long Cable (80) with Cable Clips (51). Attach the Leg Press Strap (not shown) to both ends of the Long Cable, or the optional lat bar to the Short Cables (33), with two Cable Clips.

Note: A lat bar is an optional accessory for the resistance system. To purchase a lat bar, call the toll-free telephone number on the front cover of this manual and ask for model number **WEMC0442**.

ADJUSTING THE RESISTANCE

To add resistance, hold a “U”-channel on the 10-pound Center Resistance Bar (44) firmly and push the end of a resistance bar under it. Repeat with the other end of the resistance bar. If more resistance is needed, add one resistance bar at a time.

Note: When adding resistance, always start with the heaviest resistance bar to be used, and finish with the lightest resistance bar. When removing resistance bars from the “U”-channels, start with the lightest resistance bar and finish with the heaviest.

⚠ WARNING: When adding resistance, make sure that both ends of the resistance bar rest under the two “U”-channels. The rings on the Removable resistance bar (36, 67) must be pushed against the Tray (35). Do not add or remove resistance bars from the “U”-channels while an end of the Long Cable (80) is pulled out.

Note: The resistance system uses progressive resistance. As the resistance bars begin to bend, the amount of resistance will increase gradually. As the resistance bars bend further, the resistance will increase rapidly.

Note: Additional resistance can be added to the resistance system. To purchase more resistance, call the toll-free telephone number on the front cover of this manual and ask for model number **WEMC0642** (100-pound MAX PACK) or **WEMC0942** (200-pound MAX PACK).

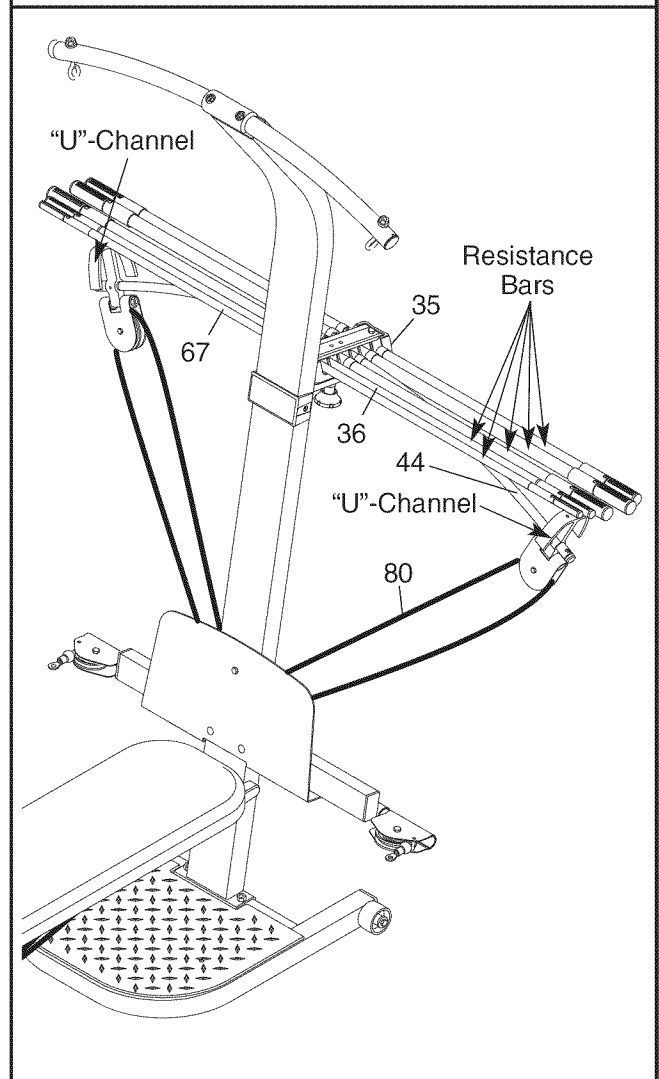
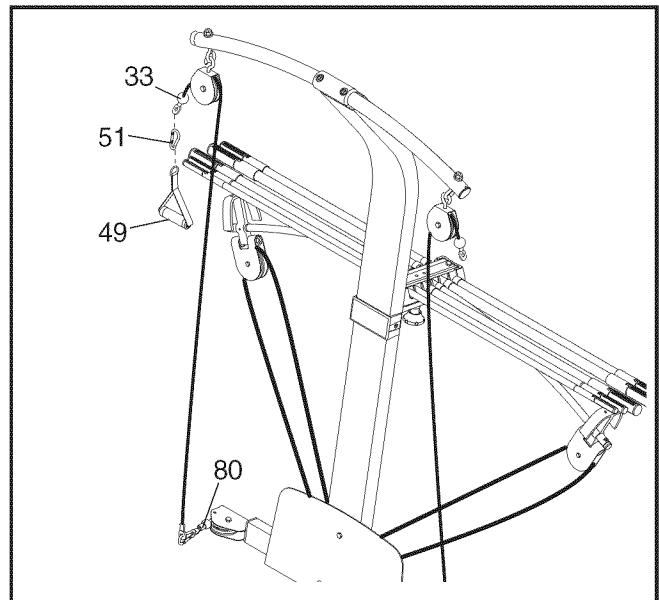

ADJUSTING THE BACKREST

The Backrest (14) can be used in a level position or one of three inclined positions. To use the Backrest in a level position, secure the Seat Carriage (12) at the hole in the Bench Rail (5) closest to the Leg Developer (19) (see ADJUSTING THE SEAT on page 13).

To use the Backrest (14) in an inclined position, secure the Seat Frame (12) at one of the three adjustment holes on the Upright (3) side of the Bench Rail (5). Rest the Backrest against the Upright (3).

For row exercises and for using the Leg Lever (7), remove the Backrest (14) from the Seat Carriage (12). Hold the Backrest vertically over the Seat (13) and lift the rod out of the slot in the Seat Carriage (see the inset drawing). To use the Leg Lever (7), secure the Seat Carriage (12) at the second hole from the Leg Developer.

STORING THE RESISTANCE SYSTEM

To store the resistance system, slide the ends of the Leg Lever Cable (32) onto the Hook (104). Be sure the Seat (13) is in the position closest to the Front Leg (6) (see ADJUSTING THE SEAT on page 13). Next, remove the Storage Knob (30) from the Upright (3). Lift the Front Leg toward the Top Frame (10), and tighten the Storage Knob into the side of the Upright and the Bench Rail. Remove all of the resistance bars from the "U"-channels on the 10-pound Center Resistance Bar (44) (see ADJUSTING THE RESISTANCE on page 14). Finally, loosen the Fulcrum Knob (43) and pull it out as far as it will go. Turn the resistance bar assembly vertically and engage the Fulcrum Knob into the fulcrum on the Lat Tower (4). **Note: Storing the resistance bars vertically will prolong the life of the resistance bars.**

To move the resistance system, place the toe of your shoe on the end of the Base (1) and hold the resistance system in the indicated area. Tilt the resistance system back onto the Wheels (31) and roll it to the new location. **Be careful not to let the Front Leg (6) or Leg Lever (7) pinch your hands when you tilt the system back.**

▲ WARNING: Make sure that all of the resistance bars are removed from the "U"-channels before moving the resistance bar assembly to the stored position.

Make sure that the resistance bar assembly is in the horizontal position and that the Storage Knob (30) is in place and fully tightened each time the resistance system is used.

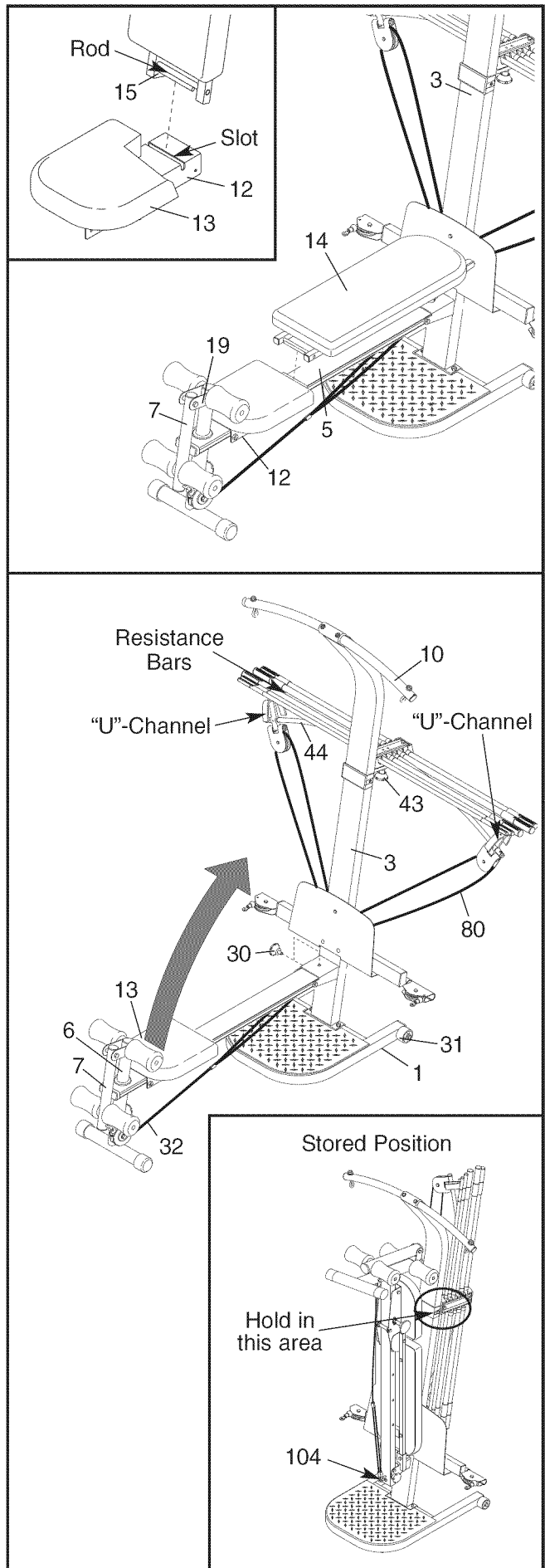

USING THE REMOVABLE RESISTANCE BARS

The Removable Resistance Bars (36, 67) can be used to exercise apart from the resistance system, as shown in the video or on the exercise guide. To remove a Resistance Bar, pull it out of the Tray (35).

To replace the Removable Resistance Bars (36, 67), slide them into the Tray (35) from the side shown, so that the arrows on the rings point toward the Tray. **Make sure the rings are pushed against the Tray.**

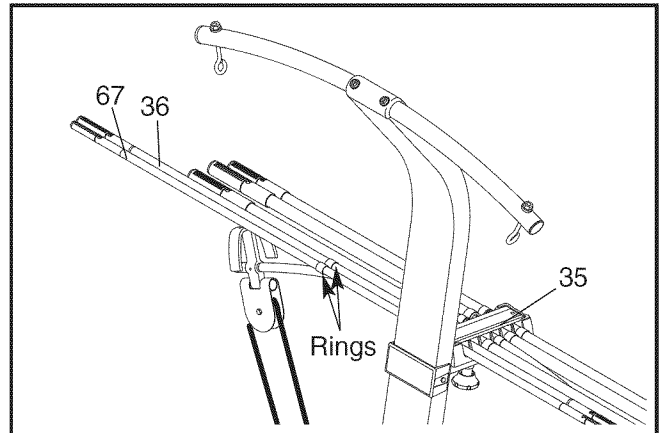

ADJUSTING THE LEG DEVELOPER

To adjust the height of the Leg Developer (19), remove the Bench Knob (42) from the Front Leg (6). Align the hole in the Leg Developer with one of the holes in the Front Leg. Retighten the Knob into the Front Leg and Leg Developer.

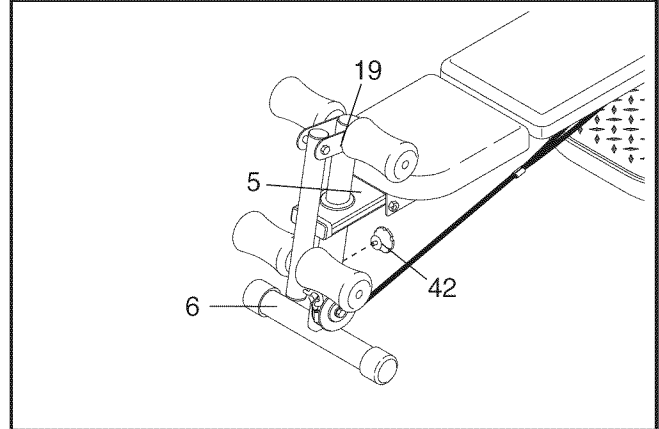

CABLE DIAGRAM

The cable diagram shows the proper routing of the Long Cable (80). Use the diagram to make sure that the cable has been assembled correctly. If the cable has not been correctly routed, the resistance system will not function properly and damage may occur. The numbers show the correct route for the cable.

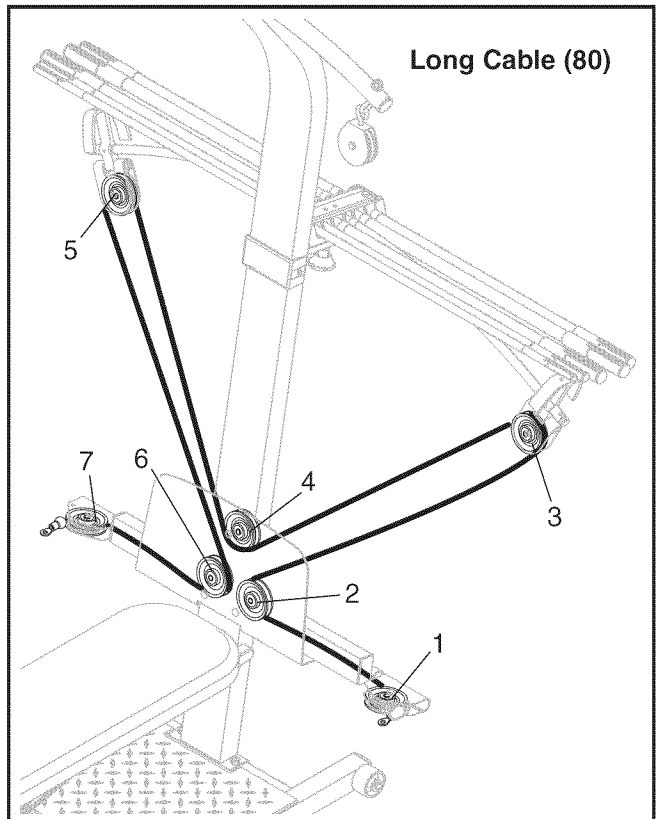

EXERCISE GUIDELINES

THE FOUR BASIC TYPES OF WORKOUTS

Muscle Building

To increase the size and strength of your muscles, push them close to their maximum capacity. Your muscles will continually adapt and grow as you progressively increase the intensity of your exercise. You can adjust the intensity level of an individual exercise in two ways:

- by changing the amount of resistance used
- by changing the number of repetitions or sets performed. (A “repetition” is one complete cycle of an exercise, such as one sit-up. A “set” is a series of repetitions.)

The proper amount of resistance for each exercise depends upon the individual user. You must gauge your limits and select the amount of resistance that is right for you. Begin with 3 sets of 8 repetitions for each exercise you perform. Rest for 3 minutes after each set. When you can complete 3 sets of 12 repetitions without difficulty, increase the amount of resistance.

Toning

You can tone your muscles by pushing them to a moderate percentage of their capacity. Select a moderate amount of resistance and increase the number of repetitions in each set. Complete as many sets of 15 to 20 repetitions as possible without discomfort. Rest for 1 minute after each set. Work your muscles by completing more sets rather than by using high amounts of resistance.

Weight Loss

To lose weight, use a low amount of resistance and increase the number of repetitions in each set. Exercise for 20 to 30 minutes, resting for a maximum of 30 seconds between sets.

Cross Training

Cross training is an efficient way to get a complete and well-balanced fitness program. An example of a balanced program is:

- Plan strength training workouts on Monday, Wednesday, and Friday.
- Plan 20 to 30 minutes of aerobic exercise, such as running on a treadmill or riding on an elliptical or exercise bike, on Tuesday and Thursday.
- Rest from both strength training and aerobic exercise for at least one full day each week to give your body time to regenerate.

The combination of strength training and aerobic exercise will reshape and strengthen your body, plus develop your heart and lungs.

PERSONALIZING YOUR EXERCISE PROGRAM

Determining the exact length of time for each workout, as well as the number of repetitions or sets completed, is an individual matter. It is important to avoid overdoing it during the first few months of your exercise program. You should progress at your own pace and be sensitive to your body’s signals. If you experience pain or dizziness at any time while exercising, stop immediately and begin cooling down. Find out what is wrong before continuing. Remember that adequate rest and a proper diet are important factors in any exercise program.

WARMING UP

Begin each workout with 5 to 10 minutes of stretching and light exercise to warm up. Warming up prepares your body for more strenuous exercise by increasing circulation, raising your body temperature and delivering more oxygen to your muscles.

WORKING OUT

Each workout should include 6 to 10 different exercises. Select exercises for every major muscle group, emphasizing areas that you want to develop most. To give balance and variety to your workouts, vary the exercises from session to session.

Schedule your workouts for the time of day when your energy level is the highest. Each workout should be followed by at least one day of rest. Once you find the schedule that is right for you, stick with it.

EXERCISE FORM

Maintaining proper form is an essential part of an effective exercise program. This requires moving through the full range of motion for each exercise, and moving only the appropriate parts of the body. Exercising in an uncontrolled manner will leave you feeling exhausted. On the exercise guide accompanying this manual you will find photographs showing the correct form for several exercises, and a list of the muscles affected. Refer to the muscle chart on page 18 to find the names of the muscles.

The repetitions in each set should be performed smoothly and without pausing. The exertion stage of each repetition should last about half as long as the return stage. Proper breathing is important. Exhale during the exertion stage of each repetition and inhale during the return stroke. Never hold your breath.

Rest for a short period of time after each set. The ideal resting periods are:

- Rest for three minutes after each set for a muscle building workout.
- Rest for one minute after each set for a toning workout.
- Rest for 30 seconds after each set for a weight loss workout.

Plan to spend the first couple of weeks familiarizing yourself with the equipment and learning the proper form for each exercise.

COOLING DOWN

End each workout with 5 to 10 minutes of stretching. Include stretches for both your arms and legs. Move

slowly as you stretch and do not bounce. Ease into each stretch gradually and go only as far as you can without strain. Stretching at the end of each workout is an effective way to increase flexibility.

STAYING MOTIVATED

For motivation, keep a record of each workout. The chart on page 19 of this manual can be photocopied and used to schedule and record your workouts. List the date, the exercises performed, the resistance used, and the numbers of sets and repetitions completed. Record your weight and key body measurements at the end of every month. Remember, the key to achieving the greatest results is to make exercise a regular and enjoyable part of your everyday life.

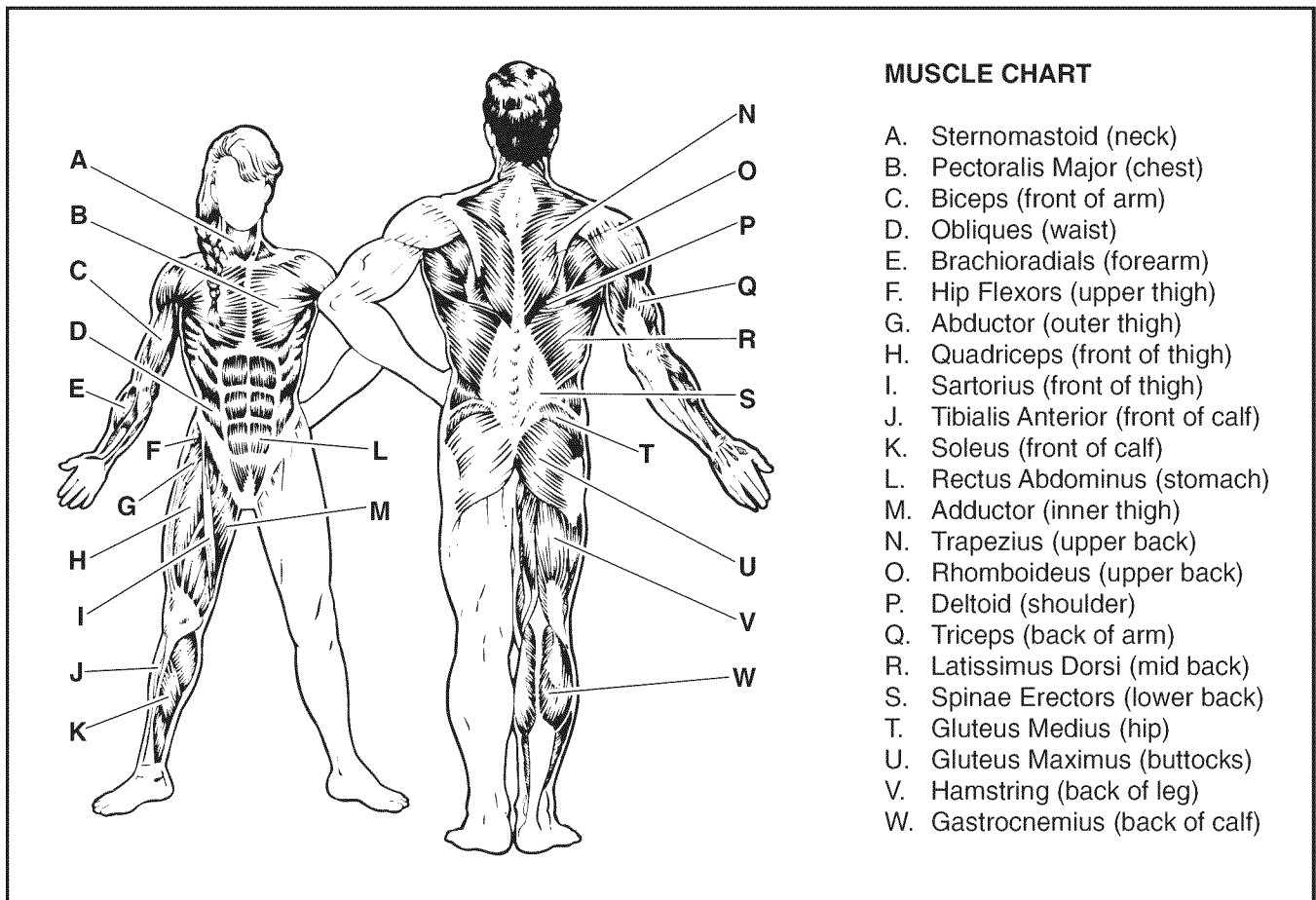

MONDAY	EXERCISE	RESISTANCE	SETS	REPS
Date: _____ / _____ / _____				

TUESDAY AEROBIC EXERCISE

Date: _____ / _____ / _____

WEDNESDAY	EXERCISE	RESISTANCE	SETS	REPS
Date: _____ / _____ / _____				

THURSDAY AEROBIC EXERCISE

Date: _____ / _____ / _____

FRIDAY	EXERCISE	RESISTANCE	SETS	REPS
Date: _____ / _____ / _____				

Make photocopies of this page for scheduling and recording your workouts.

PART IDENTIFICATION CHART

Refer to the drawings below to identify small parts used in assembly. The number in parentheses below each drawing is the key number of the part, from the PART LIST on the reverse side of this page. **Note: Some small parts may have been pre-attached. If a part is not in the parts bag, check to see if it has been pre-attached.**

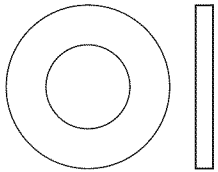

M10 Washer (75)

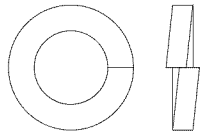

M10 Split Washer (103)

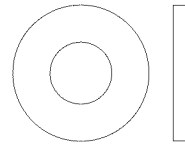

M8 Washer (59)



M8 Split Washer (52)

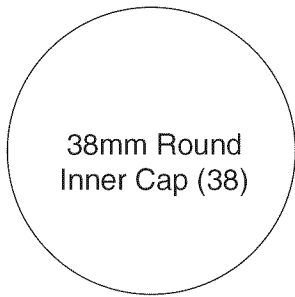

38mm Round Inner Cap (38)

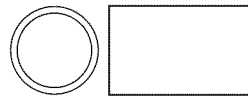
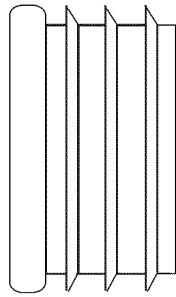

19mm Spacer (17)

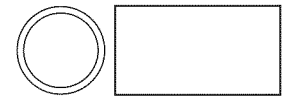

22mm Spacer (106)

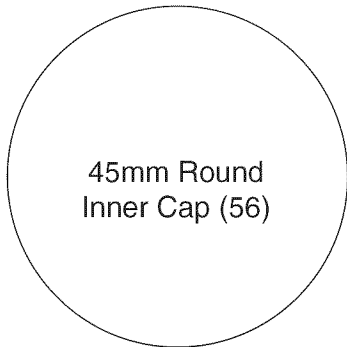

45mm Round Inner Cap (56)

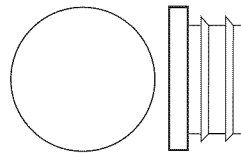
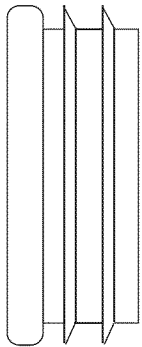

19mm Round Inner Cap (78)

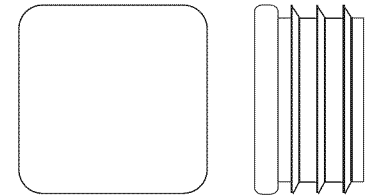

25mm Square Inner Cap (54)

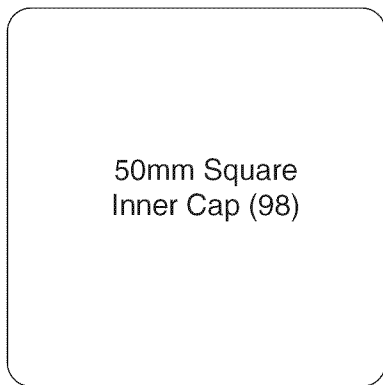

50mm Square Inner Cap (98)

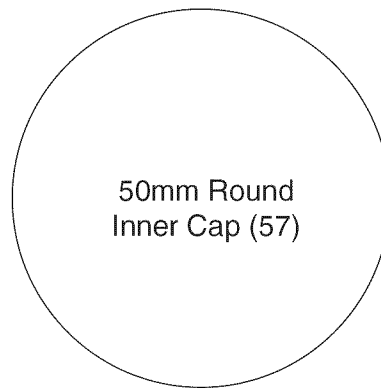
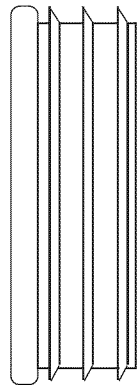

50mm Round Inner Cap (57)

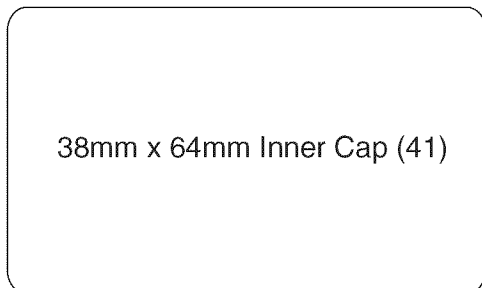
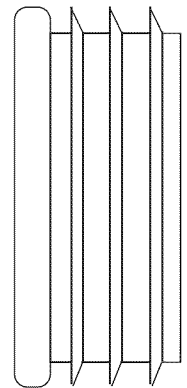

38mm x 64mm Inner Cap (41)

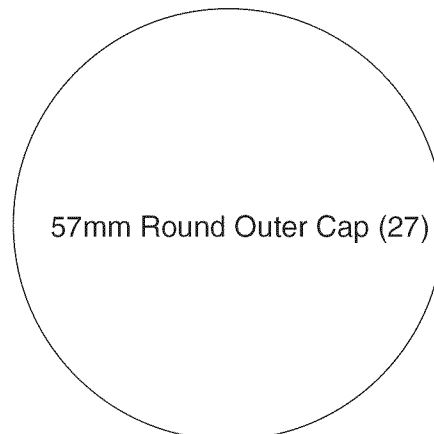
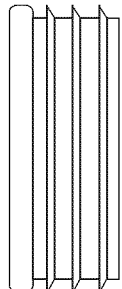

57mm Round Outer Cap (27)

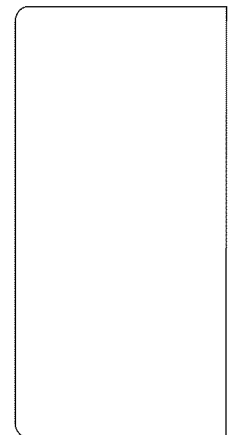



M6 Black Nylon Locknut (69)

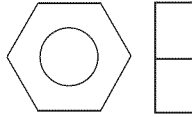

M10 Nut (47)

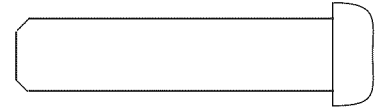

M10 x 42mm Button Head Bolt (71)

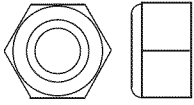

M8 Nylon Locknut (65)

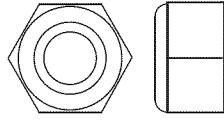

M10 Nylon Locknut (76)

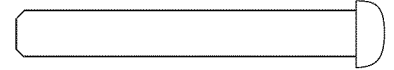

M6 x 45mm Screw (58)

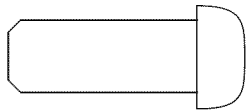

M10 x 25mm Button Head Screw (87)

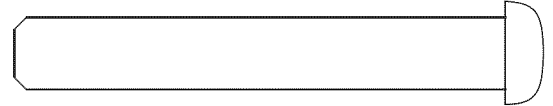

M10 x 65mm Button Head Screw (70)

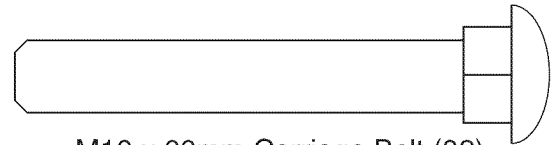

M10 x 66mm Carriage Bolt (83)

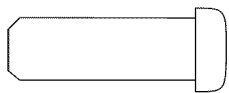

M8 x 25mm Button Head Screw (46)

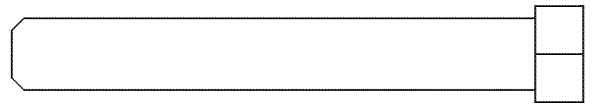

M10 x 69mm Bolt (60)

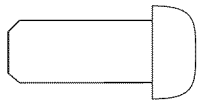

M8 x 19mm Button Head Screw (86)

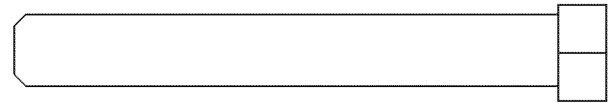

M10 x 72mm Bolt (64)

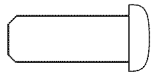

M6 x 16mm Screw (82)

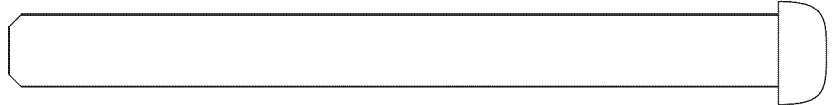

M10 x 102mm Button Head Bolt (24)

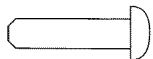

M4 x 16mm Screw (62)

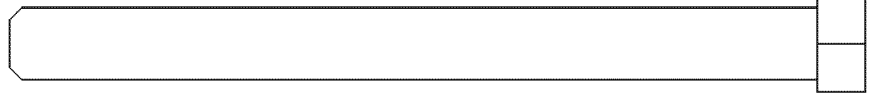

M10 x 107mm Bolt (97)



M4 x 12mm Flat Head Screw (85)

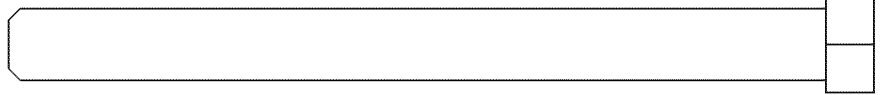

M10 x 108mm Bolt (81)



M4 x 5mm Screw (107)

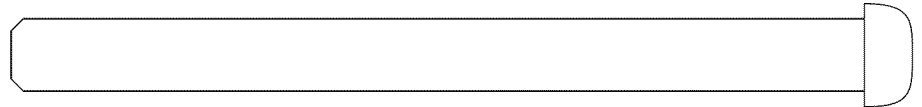

M10 x 113mm Button Head Bolt (40)

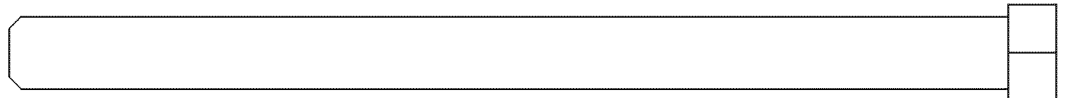

M10 x 132mm Bolt (66)

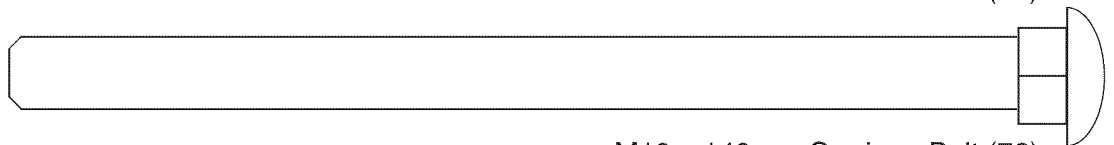

M10 x 140mm Carriage Bolt (73)

PART LIST—Model No. WESY5993.3

R1005A

Key No.	Qty.	Description	Key No.	Qty.	Description
1	1	Base	58	4	M6 x 45mm Screw
2	1	Base Plate	59	2	M8 Washer
3	1	Upright	60	1	M10 x 69mm Bolt
4	1	Lat Tower	61	6	Seat Wheel
5	1	Bench Rail	62	15	M4 x 16mm Screw
6	1	Front Leg	63	6	M6 Zinc Nylon Locknut
7	1	Leg Lever	64	2	M10 x 72mm Bolt
8	1	Backrest Backing	65	3	M8 Nylon Locknut
9	1	Seat Backing	66	1	M10 x 132mm Bolt
10	1	Top Frame	67	1	10-pound Removable Resistance Bar
11	1	Cross Tube			
12	1	Seat Carriage	68	2	Long Handle
13	1	Seat	69	2	M6 Black Nylon Locknut
14	1	Backrest	70	2	M10 x 65mm Button Head Screw
15	1	Backrest Frame	71	6	M10 x 42mm Button Head Bolt
16	1	Backrest Cap	72	1	Cover Plate
17	1	19mm Spacer	73	2	M10 x 140mm Carriage Bolt
18	1	Fulcrum	74	4	Pivot Bushing
19	1	Leg Developer	75	10	M10 Washer
20	2	10-pound Short Cap	76	20	M10 Nylon Locknut
21	2	High Pulley Housing	77	6	M6 Shoulder Bolt
22	2	Swivel Arm	78	4	19mm Round Inner Cap
23	1	Foot Plate	79	2	40-pound Cap
24	2	M10 x 102mm Button Head Bolt	80	1	Long Cable
25	4	Arm Bushing	81	2	M10 x 108mm Bolt
26	4	Foam Pad	82	12	M6 x 16mm Screw
27	2	57mm Round Outer Cap	83	2	M10 x 66mm Carriage Bolt
28	9	90mm Pulley	84	1	Fulcrum Endcap
29	3	Pulley Guard	85	12	M4 x 12mm Flat Head Screw
30	1	Storage Knob	86	2	M8 x 19mm Button Head Screw
31	2	Wheel	87	4	M10 x 25mm Button Head Screw
32	1	Leg Lever Cable	88	2	20-pound Cap
33	2	Short Cable	89	1	Name Plate
34	2	Eyebolt	90	6	11mm Spacer
35	1	Tray	91	1	Retainer Ring
36	1	20-pound Removable Resistance Bar	92	1	"V"-pulley
			93	1	Top Frame Cover
37	2	Fulcrum Bushing	94	2	Pulley Housing
38	2	38mm Round Inner Cap	95	2	80-pound Resistance Bar
39	1	Bench Rail Bracket	96	1	40-pound Resistance Bar
40	1	M10 x 113mm Button Head Bolt	97	1	M10 x 107mm Bolt
41	2	38mm x 64mm Inner Cap	98	2	50mm Square Inner Cap
42	1	Bench Knob	99	2	Rail Inner Cap
43	1	Fulcrum Knob	100	4	80-pound Cap
44	1	10-pound Center Resistance Bar	101	2	10-pound Cap
45	1	Seat Knob	102	2	Large Plastic Foot
46	4	M8 x 25mm Button Head Screw	103	4	M10 Split Washer
47	2	M10 Nut	104	1	Hook
48	1	Leg Press Strap	105	1	Rail Bracket
49	2	Short Handle	106	1	22mm Spacer
50	1	Ankle Strap	107	2	M4 x 5mm Screw
51	5	Cable Clip	108	1	Storage Knob Bracket
52	4	M8 Split Washer	#	1	User's Manual
53	3	Plastic Foot	#	1	Exercise Guide
54	2	25mm Square Inner Cap	#	1	Exercise Decal
55	1	45mm Round Inner Bushing	#	1	Large Allen Wrench
56	2	45mm Round Inner Cap	#	1	Small Allen Wrench
57	2	50mm Round Inner Cap			

Note: “#” indicates a non-illustrated part. Specifications are subject to change without notice. See the back cover of the user's manual for information about ordering replacement parts.

EXPLODED DRAWING—Model No. WESY5993.3

R1005A

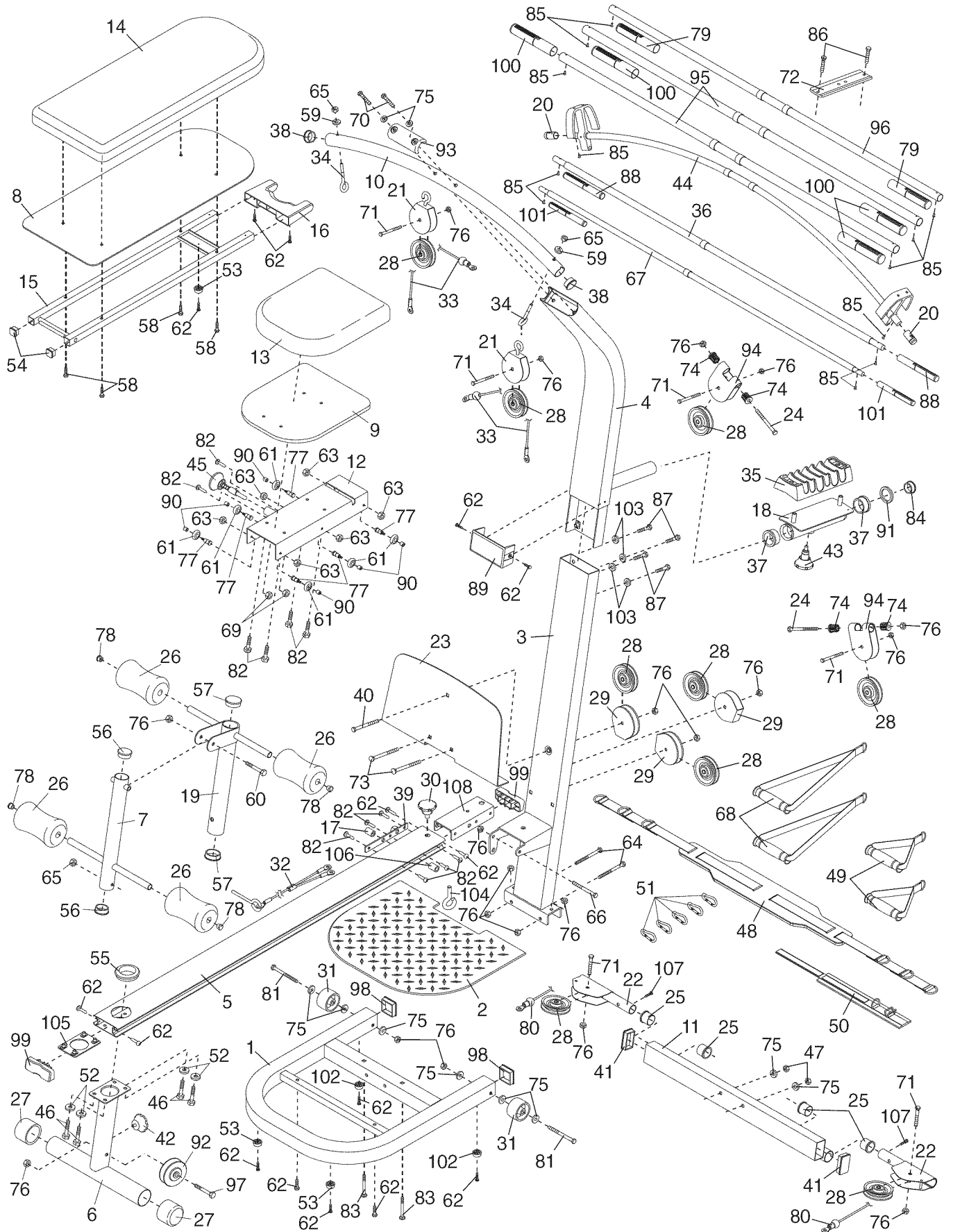

ORDERING REPLACEMENT PARTS

To order replacement parts, see the front cover of this manual. To help us assist you, please be prepared to give the following information:

- the MODEL NUMBER of the product (WESY5993.3)
- the NAME of the product (MAX by WEIDER LEGEND resistance system)
- the SERIAL NUMBER of the product (see the front cover of this manual)
- the KEY NUMBER and DESCRIPTION of the part(s) (see the PART LIST and EXPLODED DRAWING in the center of this manual)

LIMITED WARRANTY

ICON Health & Fitness, Inc. (ICON), warrants this product to be free from defects in workmanship and material, under normal use and service conditions, for a period of five (5) years from the date of purchase. ICON warrants the resistance bars for the lifetime of the product. Shipping of the resistance bars is not covered. Labor is covered for one (1) year. This warranty extends only to the original purchaser. ICON's obligation under this warranty is limited to replacing or repairing, at ICON's option, the product through one of its authorized service centers. All repairs for which warranty claims are made must be pre-authorized by ICON. If the product is shipped to a service center, freight charges to and from the service center will be the customer's responsibility. For in-home service, the customer will be responsible for a minimal trip charge. This warranty does not extend to any product or damage to a product caused by or attributable to freight damage, abuse, misuse, improper or abnormal usage or repairs not provided by an ICON authorized service center; products used for commercial or rental purposes; or products used as store display models. No other warranty beyond that specifically set forth above is authorized by ICON.

ICON is not responsible or liable for indirect, special or consequential damages arising out of or in connection with the use or performance of the product or damages with respect to any economic loss, loss of property, loss of revenues or profits, loss of enjoyment or use, costs of removal or installation or other consequential damages of whatsoever nature. Some states do not allow the exclusion or limitation of incidental or consequential damages. Accordingly, the above limitation may not apply to you.

The warranty extended hereunder is in lieu of any and all other warranties and any implied warranties of merchantability or fitness for a particular purpose is limited in its scope and duration to the terms set forth herein. Some states do not allow limitations on how long an implied warranty lasts. Accordingly, the above limitation may not apply to you.

This warranty gives you specific legal rights. You may also have other rights which vary from state to state.

ICON HEALTH & FITNESS, INC., 1500 S. 1000 W., LOGAN, UT 84321-9813