



LG
Life's Good

LCD TV | PLASMA TV OWNER'S MANUAL

LCD TV MODELS

42LH50
47LH50
55LH50

PLASMA TV MODELS

50PS80
60PS80

Please read this manual carefully before operating your set and retain it for future reference.

The model and serial number of the TV is located on the back and one side of the TV.

Record it below should you ever need service.

Model:

Serial:

1-800-243-0000 USA, Consumer User
1-888-865-3026 USA, Commercial User
1-888-542-2623 CANADA

LG Customer Information Center



This product qualifies for ENERGY STAR in the "factory default (Home Use)" setting.

Changing the factory default settings or enabling other features may increase power consumption that could exceed the limits necessary to qualify for ENERGY STAR.

Yahoo Support <http://connectedtv.yahoo.com/help>
Netflix Support <http://www.netflix.com/tvhelp>
YouTube Support http://www.youtube.com/t/contact_us
Vudu Support <http://www.vudu.com/support>

P/NO : SAC33601909 (0909-REV01)

www.lgusa.com

WARNING / CAUTION



WARNING / CAUTION
RISK OF ELECTRIC SHOCK
DO NOT OPEN



**TO REDUCE THE RISK OF ELECTRIC SHOCK
DO NOT REMOVE COVER (OR BACK). NO
USER SERVICEABLE PARTS INSIDE. REFER TO
QUALIFIED SERVICE PERSONNEL.**



The lightning flash with arrowhead symbol, within an equilateral triangle, is intended to alert the user to the presence of uninsulated "dangerous voltage" within the product's enclosure that may be of sufficient magnitude to constitute a risk of electric shock to persons.



The exclamation point within an equilateral triangle is intended to alert the user to the presence of important operating and maintenance (servicing) instructions in the literature accompanying the appliance.

WARNING/CAUTION

TO REDUCE THE RISK OF FIRE AND ELECTRIC SHOCK, DO NOT EXPOSE THIS PRODUCT TO RAIN OR MOISTURE.

NOTE TO CABLE/TV INSTALLER

This reminder is provided to call the CATV system installer's attention to Article 820-40 of the National Electric Code (U.S.A.). The code provides guidelines for proper grounding and, in particular, specifies that the cable ground shall be connected to the grounding system of the building, as close to the point of the cable entry as practical.

WARNING / CAUTION

To prevent fire or shock hazards, do not expose this product to rain or moisture.

FCC NOTICE

Class B digital device

This equipment has been tested and found to comply with the limits for a Class B digital device, pursuant to Part 15 of the FCC Rules. These limits are designed to provide reasonable protection against harmful interference in a residential installation. This equipment generates, uses and can radiate radio frequency energy and, if not installed and used in accordance with the instructions, may cause harmful interference to radio communications. However, there is no guarantee that interference will not occur in a particular installation. If this equipment does cause harmful interference to radio or television reception, which can be determined by turning the equipment off and on, the user is encouraged to try to correct the interference by one or more of the following measures:

- Reorient or relocate the receiving antenna.
- Increase the separation between the equipment and receiver.
- Connect the equipment to an outlet on a circuit different from that to which the receiver is connected.
- Consult the dealer or an experienced radio/TV technician for help.

This device complies with part 15 of the FCC Rules. Operation is subject to the following two conditions: (1) This device may not cause (harmful) interference, and (2) this device must accept any interference received, including interference that may cause undesired operation (of the device).

Any changes or modifications in construction of this device which are not expressly approved by the party responsible for compliance could void the user's authority to operate the equipment.

CAUTION

Do not attempt to modify this product in any way without written authorization from LG Electronics. Unauthorized modification could void the user's authority to operate this product.

SAFETY INSTRUCTIONS

IMPORTANT SAFETY INSTRUCTIONS

Read these instructions.

Keep these instructions.

Heed all warnings.

Follow all instructions.

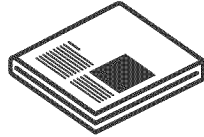

- 1** Do not use this apparatus near water.

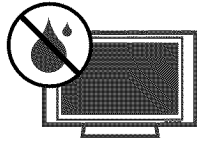

- 2** Clean only with dry cloth.



- 3** Do not block any ventilation openings. Install in accordance with the manufacturer's instructions.

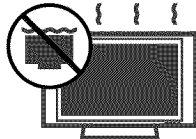

- 4** Do not install near any heat sources such as radiators, heat registers, stoves, or other apparatus (including amplifiers) that produce heat.



- 5** Do not defeat the safety purpose of the polarized or grounding-type plug. A polarized plug has two blades with one wider than the other. A grounding type plug has two blades and a third grounding prong. The wide blade or the third prong are provided for your safety. If the provided plug does not fit into your outlet, consult an electrician for replacement of the obsolete outlet.

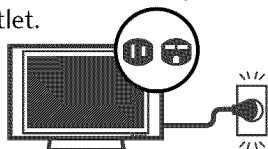

- 6** Protect the power cord from being walked on or pinched particularly at plugs, convenience receptacles, and the point where they exit from the apparatus.

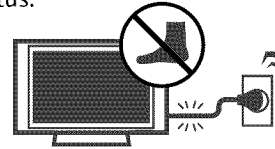

- 7** Only use attachments/accessories specified by the manufacturer.

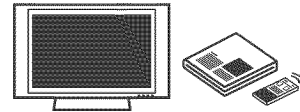

- 8** Use only with the cart, stand, tripod, bracket, or table specified by the manufacturer, or sold with the apparatus. When a cart is used, use caution when moving the cart/apparatus combination to avoid injury from tip-over.

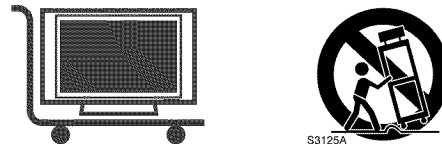

S3125A

- 9** Unplug this apparatus during lightning storms or when unused for long periods of time.

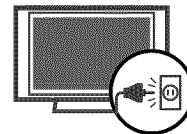

- 10** Refer all servicing to qualified service personnel. Servicing is required when the apparatus has been damaged in any way, such as power-supply cord or plug is damaged, liquid has been spilled or objects have fallen into the apparatus, the apparatus has been exposed to rain or moisture, does not operate normally, or has been dropped.

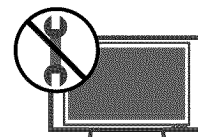

SAFETY INSTRUCTIONS

- 11** Never touch this apparatus or antenna during a thunder or lightning storm.

- 12** When mounting a TV on the wall, make sure not to install the TV by the hanging power and signal cables on the back of the TV.

- 13** Do not allow an impact shock or any objects to fall into the product, and do not drop onto the screen with something.

14 CAUTION concerning the Power Cord:

It is recommend that appliances be placed upon a dedicated circuit; that is, a single outlet circuit which powers only that appliance and has no additional outlets or branch circuits. Check the specification page of this owner's manual to be certain.

Do not connect too many appliances to the same AC power outlet as this could result in fire or electric shock.

Do not overload wall outlets. Overloaded wall outlets, loose or damaged wall outlets, extension cords, frayed power cords, or damaged or cracked wire insulation are dangerous. Any of these conditions could result in electric shock or fire. Periodically examine the cord of your appliance, and if its appearance indicates damage or deterioration, unplug it, discontinue use of the appliance, and have the cord replaced with an exact replacement part by an authorized servicer. Protect the power cord from physical or mechanical abuse, such as being twisted, kinked, pinched, closed in a door, or walked upon. Pay particular attention to plugs, wall outlets, and the point where the cord exits the appliance.

Do not make the TV with the power cord plugged in. Do not use a damaged or loose power cord. Be sure do grasp the plug when unplugging the power cord. Do not pull on the power cord to unplug the TV.

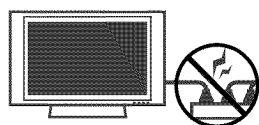

- 15** WARNING - To reduce the risk of fire or electrical shock, do not expose this product to rain, moisture or other liquids. Do not touch the TV with wet hands. Do not install this product near flammable objects such as gasoline or candles or expose the TV to direct air conditioning.

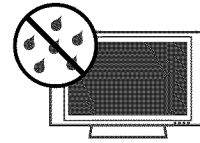

- 16** Do not expose to dripping or splashing and do not place objects filled with liquids, such as vases, cups, etc. on or over the apparatus (e.g. on shelves above the unit).

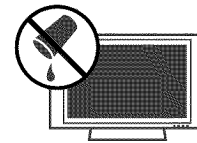

17 GROUNDING

Ensure that you connect the earth ground wire to prevent possible electric shock (i.e. a TV with a three-prong grounded AC plug must be connected to a three-prong grounded AC outlet). If grounding methods are not possible, have a qualified electrician install a separate circuit breaker.

Do not try to ground the unit by connecting it to telephone wires, lightening rods, or gas pipes.

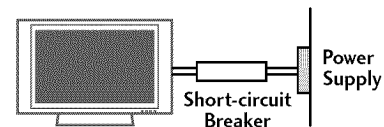

- 18** DISCONNECTING DEVICE FROM MAINS
Mains plug is the disconnecting device. The plug must remain readily operable.

- 19** As long as this unit is connected to the AC wall outlet, it is not disconnected from the AC power source even if you turn off this unit by SWITCH.

20 ANTENNAS

Outdoor antenna grounding

If an outdoor antenna is installed, follow the precautions below. An outdoor antenna system should not be located in the vicinity of overhead power lines or other electric light or power circuits, or where it can come in contact with such power lines or circuits as death or serious injury can occur.

Be sure the antenna system is grounded so as to provide some protection against voltage surges and built-up static charges.

Section 810 of the National Electrical Code (NEC) in the U.S.A. provides information with respect to proper grounding of the mast and supporting structure, grounding of the lead-in wire to an antenna discharge unit, size of grounding conductors, location of antenna discharge unit, connection to grounding electrodes and requirements for the grounding electrode.

Antenna grounding according to the National Electrical Code, ANSI/NFPA 70

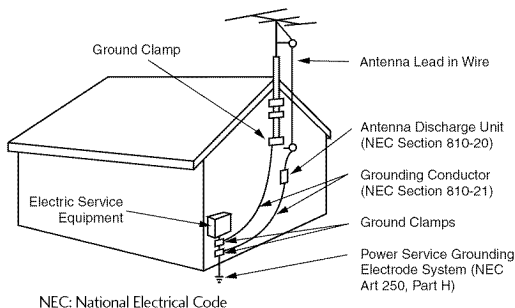

21 Cleaning

When cleaning, unplug the power cord and scrub gently with a soft cloth to prevent scratching. Do not spray water or other liquids directly on the TV as electric shock may occur. Do not clean with chemicals such as alcohol, thinners or benzene.

22 Moving

Make sure the product is turned off, unplugged and all cables have been removed. It may take 2 or more people to carry larger TVs. Do not press against or put stress on the front panel of the TV.

23 Ventilation

Install your TV where there is proper ventilation. Do not install in a confined space such as a bookcase. Do not cover the product with cloth or other materials (e.g.) plastic while plugged in. Do not install in excessively dusty places.

24 If you smell smoke or other odors coming from the TV or hear strange sounds, unplug the power cord contact an authorized service center.

25 Do not press strongly upon the panel with hand or sharp object such as nail, pencil or pen, or make a scratch on it.

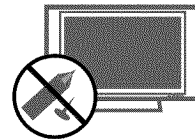

26 Keep the product away from direct sunlight.

27 For LCD TV

If the TV feels cold to the touch, there may be a small “flicker” when it is turned on. This is normal, there is nothing wrong with TV.

Some minute dot defects may be visible on the screen, appearing as tiny red, green, or blue spots. However, they have no adverse effect on the monitor’s performance.

Avoid touching the LCD screen or holding your finger(s) against it for long periods of time. Doing so may produce some temporary distortion effects on the screen.

ON DISPOSAL

(Only Hg lamp used LCD TV)

The fluorescent lamp used in this product contains a small amount of mercury. Do not dispose of this product with general household waste. Disposal of this product must be carried out in accordance to the regulations of your local authority.

CONTENTS

WARNING / CAUTION	2
SAFETY INSTRUCTIONS	3
FEATURE OF THIS TV	8

PREPARATION

Accessories	9
Front Panel Information	10
Back Panel Information	12
Stand Instructions	14
VESA Wall Mounting	18
Cable Management	19
Desktop Pedestal Installation	21
Swivel Stand	21
Attaching the TV to a Desk	22
Kensington Security System	22
Securing the TV to the wall to prevent falling when the TV is used on a stand	23
Antenna or Cable Connection	24

EXTERNAL EQUIPMENT SETUP

HD Receiver Setup	25
DVD Setup	29
VCR Setup	33
Other A/V Source Setup	36
USB Connection	36
PC Setup	37
Audio out Connection	44
Network Setup	45

WATCHING TV / CHANNEL CONTROL

Remote Control Functions	48
Turning On the TV	50
Channel Selection	50
Volume Adjustment	50
Initial Setting	51
On-Screen Menus Selection	53
Quick Menu	54
Channel Setup	

- Auto Scan (Auto Tuning)	55
- Add / Delete Channel (Manual Tuning)	56
- Channel Editing	57
Channel List	58
Favorite Channel Setup / Favorite Channel List	59
Brief Information	60
Simple Manual	61
Input List	62
Input Label	63
AV Mode	64
Key Lock	65
SIMPLINK	66

NETWORK

Software Update	68
Netflix ESN (Electronic Serial Number)	69

NETCAST

Yahoo! TV Widgets	70
Netflix	78
My Media	90
YouTube	108
NETCAST Time-Out Setting	111
Vudu	112

PICTURE CONTROL

Picture Size (Aspect Ratio) Control	128
Picture Wizard	130
Preset Picture Settings (Picture Mode)	132
Manual Picture Adjustment - User Mode	133
Picture Improvement Technology	134
Expert Picture Control	135
Energy Saving	138
Picture Reset	139
Image Sticking Minimization (ISM) Method	140
Power Indicator	141
Demo Mode	142

SOUND & LANGUAGE CONTROL

Auto Volume Leveler (Auto Volume)	143
Clear Voice II	144
Preset Sound Setting (Sound Mode)	145
Sound Setting Adjustment - User Mode	146
SRS Trusurround XT	147
Balance	148
TV Speakers On/Off Setup	149
Audio Reset	150
Stereo/SAP Broadcasts Setup	151
Audio Language	152
On-Screen Menus Language Selection	153
Caption Mode	
- Analog Broadcasting System Captions	154
- Digital Broadcasting System Captions	155
- Caption Option	156

TIME SETTING

Clock Setting	
- Auto Clock Setup	157
- Manual Clock Setup	158
Auto On/Off Time Setting	159
Sleep Timer Setting	160

PARENTAL CONTROL / RATINGS

Set Password & Lock System	161
Channel Blocking	164
Movie & TV Rating	165
Downloadable Rating	168
External Input Blocking	169

APPENDIX

Troubleshooting	170
Maintenance	174
Product Specifications	175
IR Codes	176
Open Source License	178
Legal Notice	192

FEATURE OF THIS TV

■ Some of these features are not available on all models.



High-definition television. High-resolution digital television broadcast and playback system composed of roughly a million or more pixels, 16:9 aspect-ratio screens, and AC3 digital audio. A subset of digital television, HDTV formats include 1080i and 720p resolutions.



This TV contains the detailed calibrations necessary for professional certification by the Imaging Science Foundation. The resulting ISF "day" and "night" modes will then be accessible by the user to experience the best their LG HDTV has to offer.

Sophisticated and detailed calibrations can be made through the ISFccc mode.

Detailed calibration requires a licensed technician.

Please contact your local dealer to inquire about an ISF certified technician.



AV Mode is three preset picture and audio settings. It allows the viewer to quickly switch between common settings. It includes Cinema, Sports, and Game Modes.



A unique invisible speaker system tuned by renowned audio expert, Mr. Mark Levinson. Speakers are embedded in strategic spots behind the front cabinet and use minute vibrations to turn the entire front bezel into the speaker system. The result is a clean, polished look, and enhanced audio by increasing the "sweet spot", giving a wider and richer sound field.



THX (Thomlinson Holman's Experiment) is an audio and video certification standard established by George Lucas and Thomlinson. A THX certified display guarantees screen quality that exceeds the display standard specification in both hardware and software.



Unlimited instant access to movies and TV shows with Netflix subscription.



Yahoo! TV Widgets give you the best of the Internet in perfect harmony with the simplicity and reliability of your TV. TV Widgets deliver a Cinematic Internet™ experience by converting your favorite web services for viewing on the TV.



"DivX Certified to play DivX video up to HD 1080p, including premium content"

ABOUT DIVX VIDEO: DivX® is a digital video format created by DivX, Inc. This is an official DivX Certified device that plays DivX video. Visit www.divx.com for more information and software tools to convert your files into DivX video.

ABOUT DIVX VIDEO-ON-DEMAND: This DivX Certified® device must be registered in order to play DivX Video-on-Demand (VOD) content. To generate the registration code, locate the DivX VOD section in the device setup menu. Go to vod.divx.com with this code to complete the registration process and learn more about DivX VOD.



Manufactured under license from Dolby Laboratories. "Dolby" and the double-D symbol are trademarks of Dolby Laboratories.

Dolby Digital is supported by the TV main features.

Dolby Digital Plus is only supported by VUDU & MY MEDIA.



SRS® is a trademark of SRS Labs, Inc.

TruSurround XT technology is incorporated under license from SRS Labs, Inc.



Automatically enhances and amplifies the sound of human voice frequency range to help keep dialogue audible when background noise swells.



HDMI, the HDMI logo and High-Definition Multimedia Interface are trademarks or registered trademarks of HDMI Licensing LLC."



Displays HDTV programs in full 1920 x 1080p resolution for a more detailed picture.



Advance 120Hz panel provides clearer, smoother images, even during fast action scenes creating a more stable structure for a crisper picture.



In addition to adhering to the new Energy Star 3.0 specification, LG HDTVs have energy-saving options like the ability to choose a content-specific setting, "video mute" or engaging exclusive Intelligent Sensor technology.



Unlike other sensors which can only sense brightness of ambient light, LG's "Intelligent Sensor" uses 4,096 sensing steps to evaluate its surroundings. Using a sophisticated algorithm, the LG processes picture quality elements including brightness, contrast, color, sharpness and white balance. The result is a picture optimized for its surroundings, more pleasing to watch and which can also save up to 50% in power consumption.



View videos and photos and listen to music on your TV through USB 2.0 ("videos" dependent on model).



Stream movies, TV shows and video, and get up to the minute news, stock information and weather updates directly to your TV using Yahoo!, Netflix, YouTube and Vudu.



IMPORTANT INFORMATION TO PREVENT "IMAGE BURN / BURN-IN" ON YOUR TV SCREEN

- When a fixed image (e.g. logos, screen menus, video game, and computer display) is displayed on the TV for an extended period, it can become permanently imprinted on the screen. This phenomenon is known as "image burn" or "burn-in." Image burn is not covered under the manufacturer's warranty.
- In order to prevent image burn, avoid displaying a fixed image on your TV screen for a prolonged period (2 or more hours for LCD, 1 or more hours for Plasma).
- Image burn can also occur on the letterboxed areas of your TV if you use the 4:3 aspect ratio setting for an extended period.

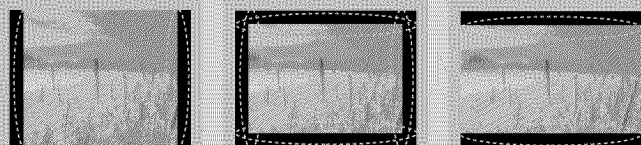

PREPARATION

ACCESSORIES

Ensure that the following accessories are included with your TV. If an accessory is missing, please contact the dealer where you purchased the TV.

The accessories included may differ from the images below.

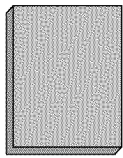

Owner's Manual

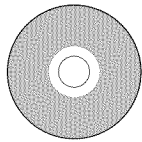

CD Manual

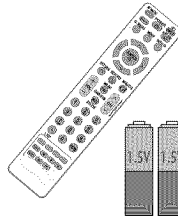

Remote Control, Batteries

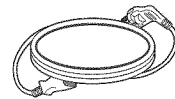

Power Cord

Not included with all models

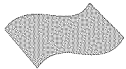

Polishing Cloth

- * Wipe spots on the exterior only with the polishing cloth.
- * Do not wipe roughly when removing stain. Excessive pressure may cause scratch or discoloration.

Option Extras

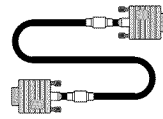

D-sub 15 pin Cable

When using the VGA (D-sub 15 pin cable) PC connection, the user must use shielded signal interface cables with ferrite cores to maintain standards compliance.

LCD TV

(For 42LH50, 47LH50)



x 4

Screws for stand assembly
(Refer to P.16)

(For 42LH50)



Screw for stand fixing
(Refer to P.22)

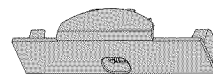

Protection Cover
(Refer to P.17)

Plasma TV

(For 50PS80)



x 4

Screws for stand assembly
(Refer to P.14)



x 2

Cable Holder
(Refer to p.19)

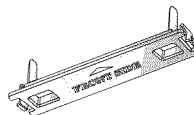

Protection Cover
(Refer to p.15)



Cable management clip
(Refer to p.19)



Ferrite Core
(White)

The ferrite core can be used to reduce the electromagnetic waves in the S-VIDEO cable. Wind the S-VIDEO cable on the ferrite core twice, and then plug the cables into the TV as shown in the following picture. Place the ferrite core close to S-VIDEO jack on the display.

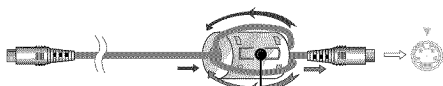

Place the ferrite core close to S-VIDEO jack on the display.

(For 60PS80)



Ferrite Core
(Black)

Ferrite core can be used to reduce the electromagnetic waves that may interfere with the TV. Install the Ferrite core on the power cable close to the wall plug.

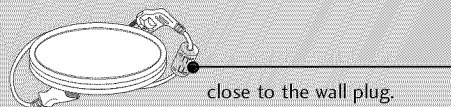

close to the wall plug.

PREPARATION

FRONT PANEL INFORMATION

■ Image shown may differ from your TV.

PREPARATION

Plasma TV

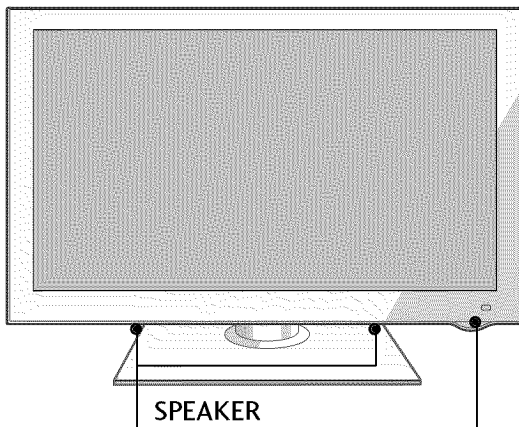

SPEAKER

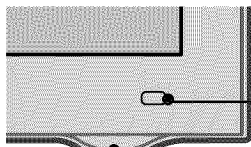

Remote Control Sensor,
Intelligent Sensor

Adjusts picture according to the
surrounding conditions

Power/Standby Indicator

Illuminates red in standby mode.

The LED is off while the TV remains on.

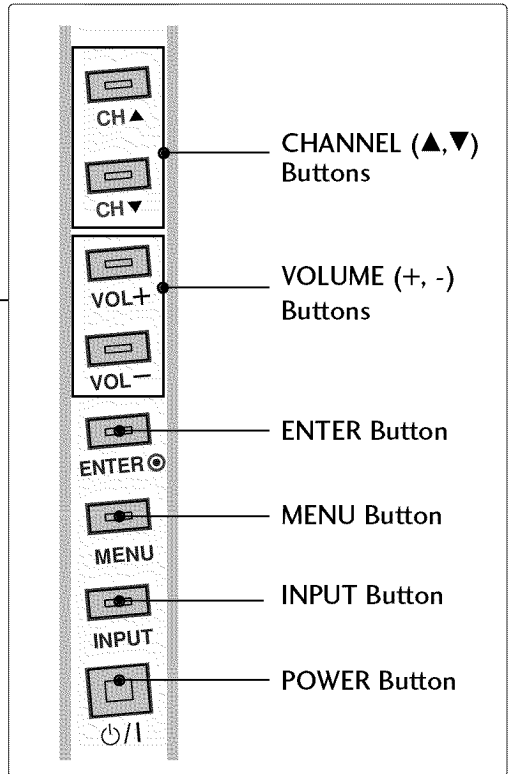

NOTE

- ▶ When the TV cannot be turned on with the remote control, press the ⏻/⏿ (POWER) button on the TV (The remote control will not work when the ⏻/⏿ (POWER) button on the TV is switched off).
- ▶ Do not drag the TV. The floor or the TV may be damaged.

LCD TV

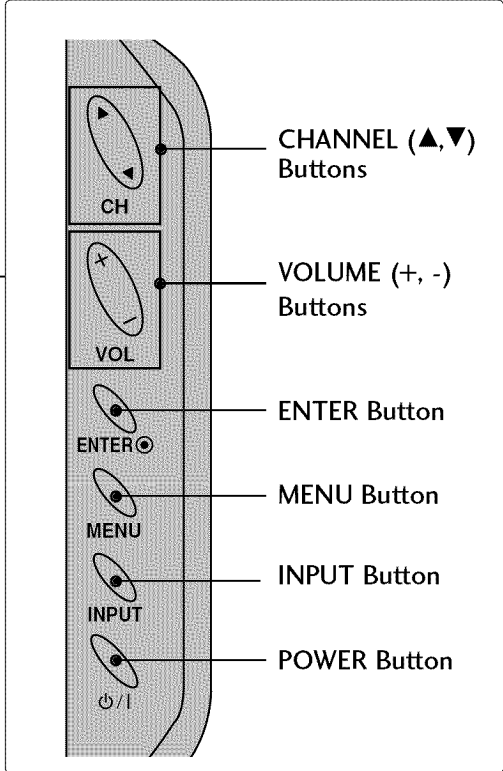
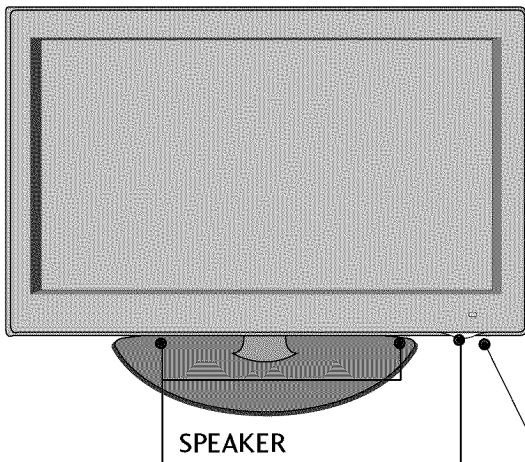

Intelligent Sensor
Adjusts picture according to the surrounding conditions

Remote Control Sensor, Power/Standby Indicator
Illuminates red in standby mode.
Illuminates blue when the TV is switched on.
(Can be adjusted using the **Power Indicator** in the **OPTION** menu. ► p.141)

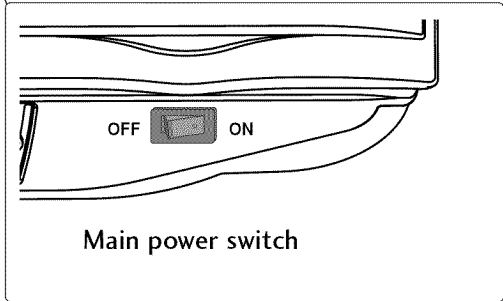

PREPARATION

BACK PANEL INFORMATION

■ Image shown may differ from your TV.

Plasma TV

PREPARATION

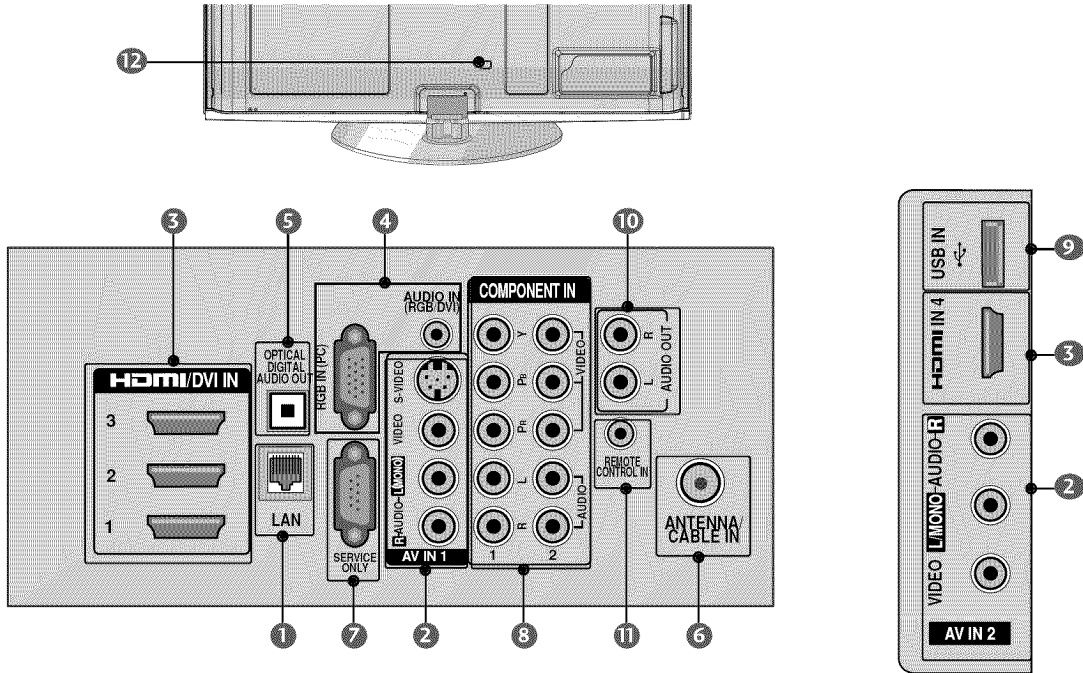

LCD TV

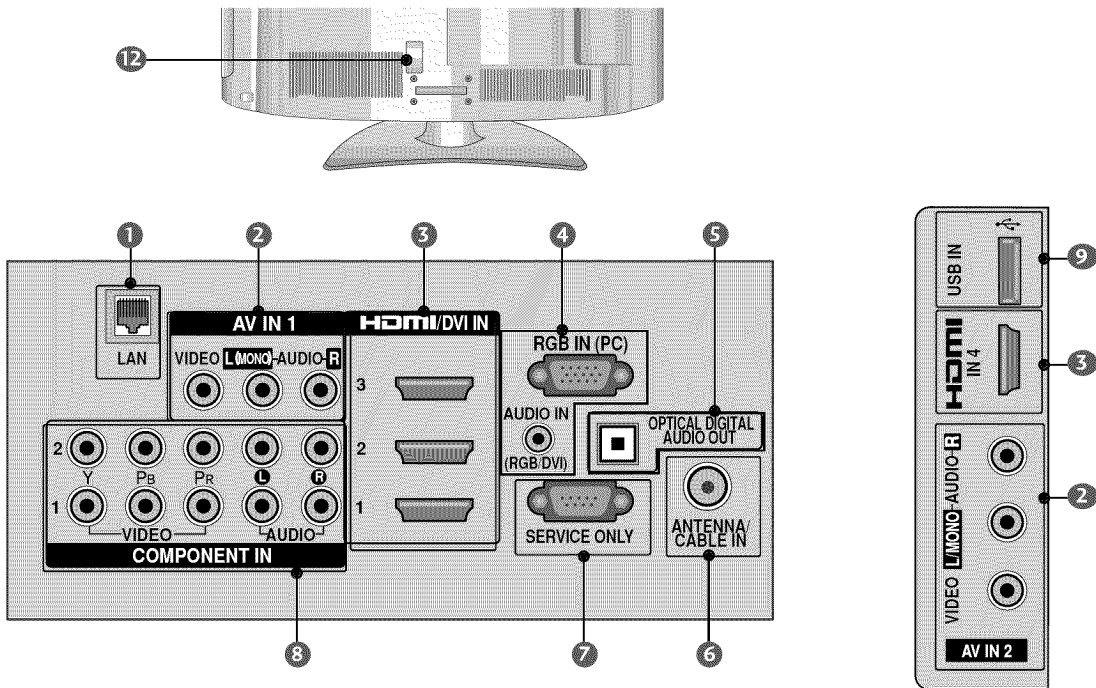

1 LAN

Network connection for Netflix, Yahoo! TV Widgets, etc. Also used for photo and music files on local network.

2 AV (Audio/Video) IN

Analog composite connection. Supports standard definition video only (480i).

3 HDMI/DVI IN, HDMI IN

Digital Connection.

Supports HD video and Digital audio. Doesn't support 480i.

Accepts DVI video using an adapter or HDMI to DVI cable (not included).

4 RGB IN (PC)

Analog PC Connection. Uses a D-sub 15 pin cable (VGA cable).

AUDIO IN (RGB/DVI)

1/8" (0.32 cm) headphone jack for analog PC audio input.

5 OPTICAL DIGITAL AUDIO OUT

Digital optical audio output for use with amps and home theater systems.

Note: In standby mode, this port doesn't work.

6 ANTENNA/CABLE IN

Connect over-the air signals to this jack.

Connect cable signals to this jack.

7 SERVICE ONLY PORT

This port is used for Service.

8 COMPONENT IN

Analog Connection.

Supports HD.

Uses a red, green, and blue cable for video & red and white for audio.

9 USB INPUT

Used for viewing photos and listening to MP3s.

10 AUDIO OUT

Analog audio output for use with amps and home theater systems.

11 REMOTE CONTROL IN PORT

For a wired remote control.

12 Power Cord Socket

For operation with AC power.

Caution: Never attempt to operate the TV on DC power.

PREPARATION

STAND INSTRUCTIONS

■ Image shown may differ from your TV.

Plasma TV

INSTALLATION (For 50PS80)

- 1 Carefully place the TV screen side down on a cushioned surface to protect the screen from damage.

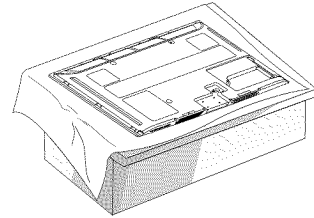

- 2 Assemble the TV as shown.

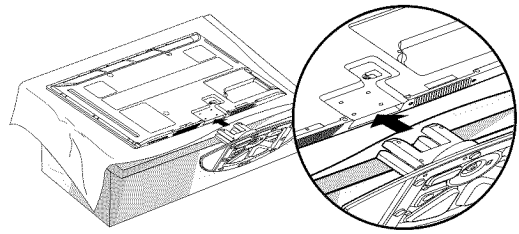

- 3 Fix the 4 screws securely using the holes in the back of the TV.

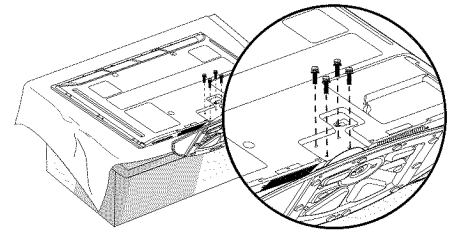

NOTE

- ▶ When assembling the stand, make sure to assemble the front and rear side of the stand correctly.
- ▶ When assembling the desk type stand, make sure the screws are fully tightened (If not tightened fully, the TV can tilt forward after the product installation). Do not over tighten.

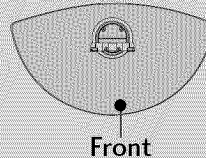

DETACHMENT

- 1 Carefully place the TV screen side down on a cushioned surface to protect the screen from damage.

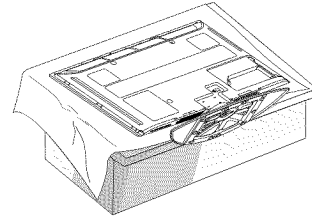

- 2 Remove the screws from the TV.

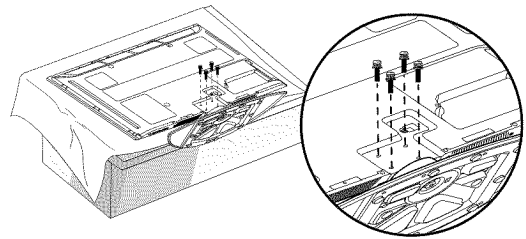

- 3 Detach the stand from TV.

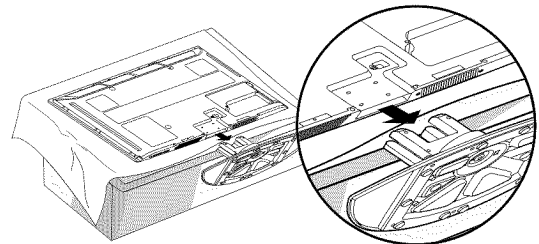

PROTECTION COVER

After removing the stand, install the included **PROTECTION COVER** over the hole for the stand.

Press the **PROTECTION COVER** into the TV until you hear it click.

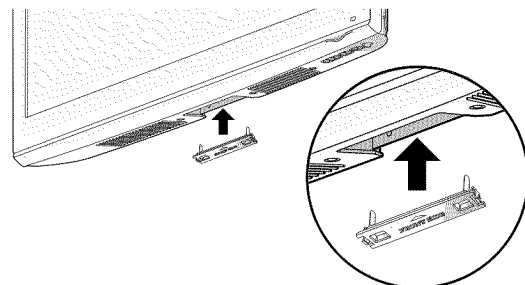

PREPARATION

STAND INSTRUCTIONS

■ Image shown may differ from your TV.

LCD TV

INSTALLATION (For 42LH50, 47LH50)

- 1 Carefully place the TV screen side down on a cushioned surface to protect the screen from damage.

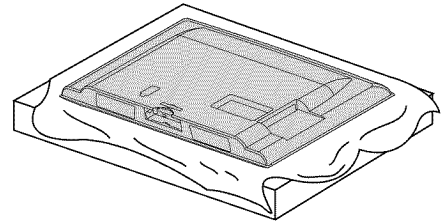

- 2 Assemble the TV as shown.

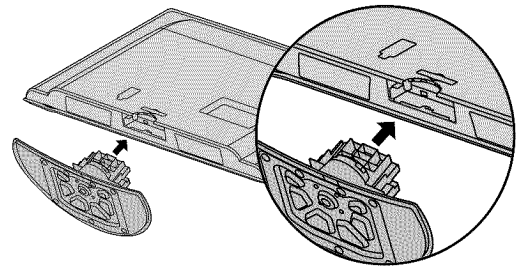

- 3 Fix the 4 screws securely using the holes in the back of the TV.

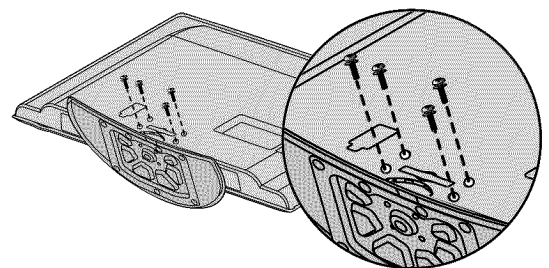

NOTE

- ▶ When assembling the desk type stand, make sure the screws are fully tightened (If not tightened fully, the TV can tilt forward after the product installation). Do not over tighten.

DETACHMENT

- 1 Carefully place the TV screen side down on a cushioned surface to protect the screen from damage.

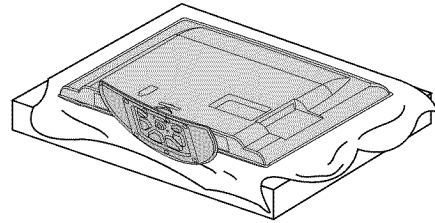

- 2 Remove the screws from the TV.

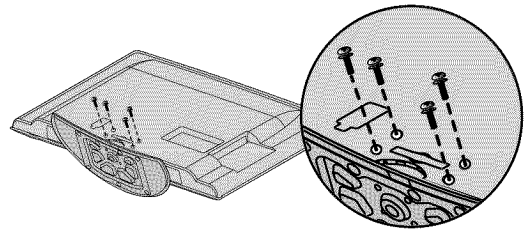

- 3 Detach the stand from TV.

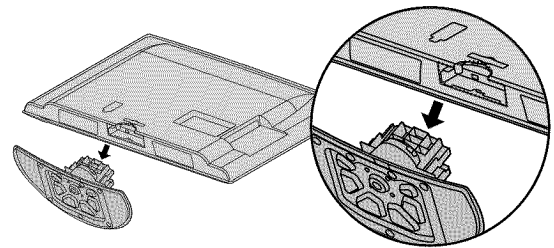

PROTECTION COVER

After removing the stand, install the included **PROTECTION COVER** over the hole for the stand.

Press the **PROTECTION COVER** into the TV until you hear it click.

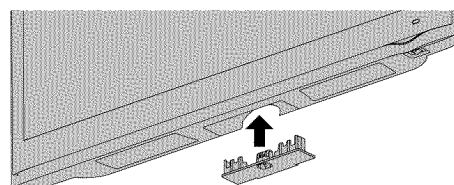

PREPARATION

VESA WALL MOUNTING

Install your wall mount on a solid wall perpendicular to the floor. When attaching to other building materials, please contact your nearest installer.

If installed on a ceiling or slanted wall, it may fall and result in severe personal injury.

We recommend that you use an LG brand wall mount when mounting the TV to a wall.

LG recommends that wall mounting be performed by a qualified professional installer.

PREPARATION

Product	Model	VESA (A * B) 	Standard Screw	Quantity	Wall Mounting Bracket (sold separately)
LCD TV	42LH50 47LH50	200 * 200	M6	4	 AW-47LG30M
	55LH50	400 * 400	M6	4	 AW-55LH40M
PLASMA TV	50PS80	400 * 400	M6	4	 AW-50PG60MS
	60PS80	600 * 400	M8	4	 AW-60PG60MS

NOTE

- ▶ Screw length needed depends on the wall mount used. For further information, refer to the instructions included with the mount.
- ▶ Standard dimensions for wall mount kits are shown in the table.
- ▶ When purchasing our wall mount kit, a detailed installation manual and all parts necessary for assembly are provided.
- ▶ Do not use screws longer than the standard dimension, as they may cause damage to the inside to the TV.
- ▶ For wall mounts that do not comply with the VESA standard screw specifications, the length of the screws may differ depending on their specifications.
- ▶ Do not use screws that do not comply with the VESA standard screw specifications.
- ▶ Do not use fasten the screws too strongly, this may damage the TV or cause the TV to a fall, leading to personal injury. LG is not liable for these kinds of accidents.
- ▶ LG is not liable for TV damage or personal injury when a non-VESA or non specified wall mount is used or the consumer fails to follow the TV installation instructions.

CAUTION ▶ Do not install your wall mount kit while your TV is turned on. It may result in personal injury due to electric shock.

CABLE MANAGEMENT

■ Image shown may differ from your TV.

Plasma TV

- 1 Connect the cables as necessary.
To connect additional equipment, see the **EXTERNAL EQUIPMENT SETUP** section.
If your TV has the **CABLE HOLDER**, install it as shown and bundle the cables.

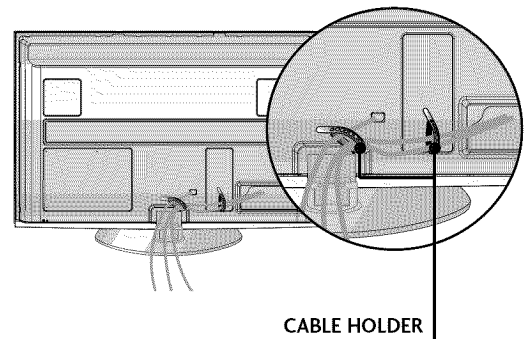

- 2 Install the **CABLE MANAGEMENT CLIP** as shown.

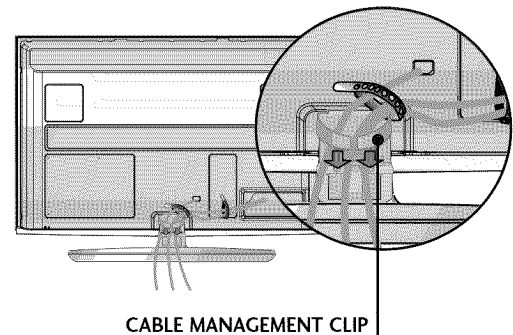

How to remove the CABLE MANAGEMENT CLIP

- ▶ Hold the **CABLE MANAGEMENT CLIP** with both hands and pull it upward.

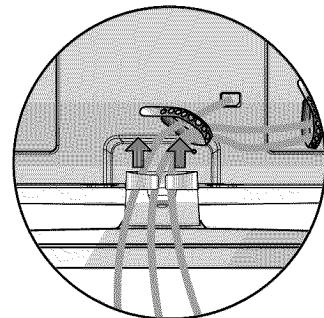

NOTE

- ▶ Do not hold the **CABLE MANAGEMENT CLIP** when moving the TV.
- If the TV is dropped, you may be injured or the product may be broken.

PREPARATION

CABLE MANAGEMENT

■ Image shown may differ from your TV.

LCD TV

- 1 Connect the cables as necessary.
To connect additional equipment, see the **EXTERNAL EQUIPMENT SETUP** section.

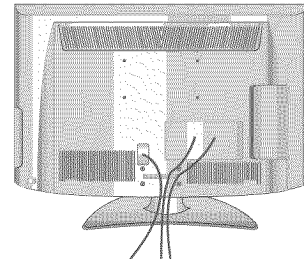

- 2 Install the **CABLE MANAGEMENT CLIP** as shown.

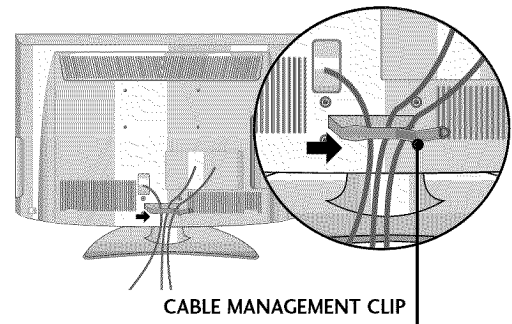

- 3 Put the cables inside the **CABLE MANAGEMENT CLIP** and snap it closed.

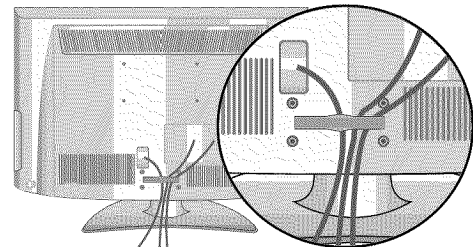

DESKTOP PEDESTAL INSTALLATION

■ Image shown may differ from your TV.

For proper ventilation, allow a clearance of 4 inches on all four sides from the wall.

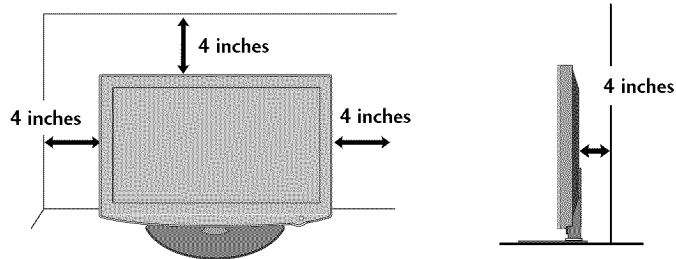

CAUTION

- ▶ Ensure adequate ventilation by following the clearance recommendations.
- ▶ Do not mount near or above any type of heat source.

SWIVEL STAND

After installing the TV, you can adjust the TV set manually to the left or right direction by 20 degrees to suit your viewing position.

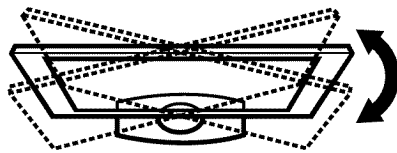

PREPARATION

ATTACHING THE TV TO A DESK (For 42LH50)

The TV must be attached to a desk so it cannot be pulled in a forward/backward direction, potentially causing injury or damaging the product.

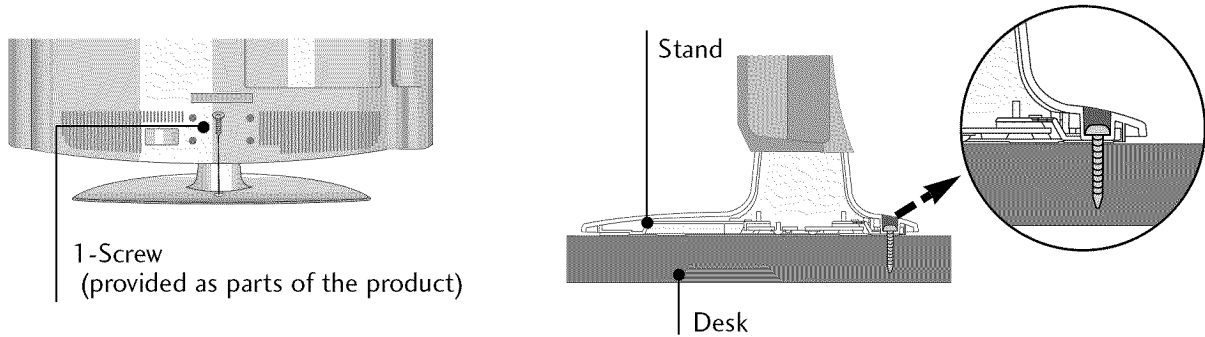

⚠ WARNING

- ▶ To prevent TV from falling over, the TV should be securely attached to the floor/wall per installation instructions. Tipping, shaking, or rocking the machine may cause injury.

KENSINGTON SECURITY SYSTEM

■ This feature is not available for all models.

- The TV is equipped with a Kensington Security System connector on the back panel. Connect the Kensington Security System cable as shown below.
- For the detailed installation and use of the Kensington Security System, refer to the user's guide provided with the Kensington Security System.

For further information, contact <http://www.kensington.com>, the internet homepage of the Kensington company. Kensington sells security systems for expensive electronic equipment such as notebook PCs and LCD projectors.

NOTE: The Kensington Security System is an optional accessory.

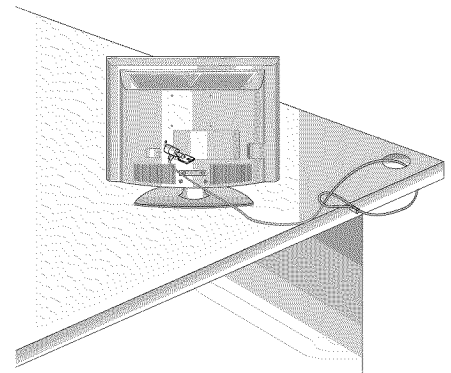

SECURING THE TV TO THE WALL TO PREVENT FALLING WHEN THE TV IS USED ON A STAND

- You should purchase necessary components to prevent the TV from tipping over (when not using a wall mount).
- Image shown may differ from your TV.

We recommend that you set up the TV close to a wall so it cannot fall over if pushed backwards. Additionally, we recommend that the TV be attached to a wall so it cannot be pulled in a forward direction, potentially causing injury or damaging the product.

Caution: Please make sure that children don't climb on or hang from the TV.

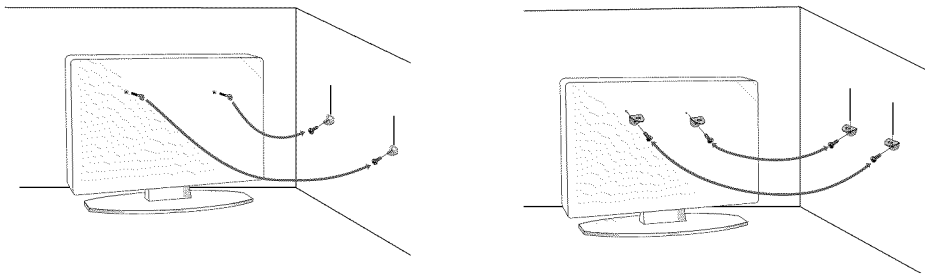

- Insert the eye-bolts (or TV brackets and bolts) to tighten the product to the wall as shown in the picture.

* If your product has the bolts in the eye-bolts position before inserting the eye-bolts, loosen the bolts.

* Insert the eye-bolts or TV brackets/bolts and tighten them securely in the upper holes.

Secure the wall brackets with the bolts (sold separately) to the wall. Match the height of the bracket that is mounted on the wall to the holes in the product.

Ensure the eye-bolts or brackets are tightened securely.

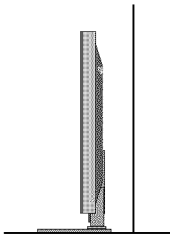

- Use a sturdy rope (sold separately) to tie the product. It is safer to tie the rope so it becomes horizontal between the wall and the product.

NOTE

- ▶ Use a platform or cabinet strong enough and large enough to support the size and weight of the TV.
- ▶ To use the TV safely make sure that the height of the bracket on the wall and the one on the TV are the same.

PREPARATION

- To prevent damage do not connect to the power outlet until all connections are made between the devices.
- Image shown may differ from your TV.

ANTENNA OR CABLE CONNECTION

PREPARATION

1. Antenna (Analog or Digital)

Wall Antenna Socket or Outdoor Antenna without a Cable Box Connections.

For optimum picture quality, adjust antenna direction if needed.

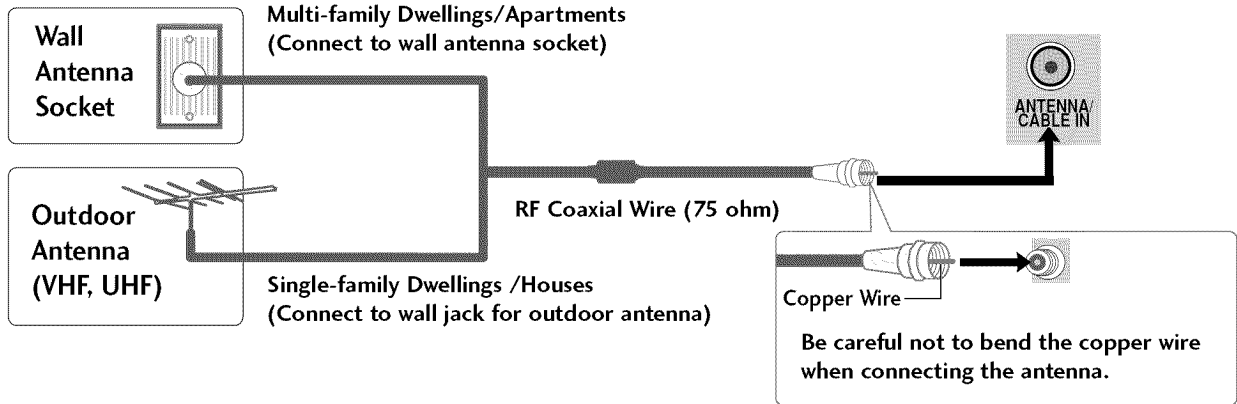

2. Cable

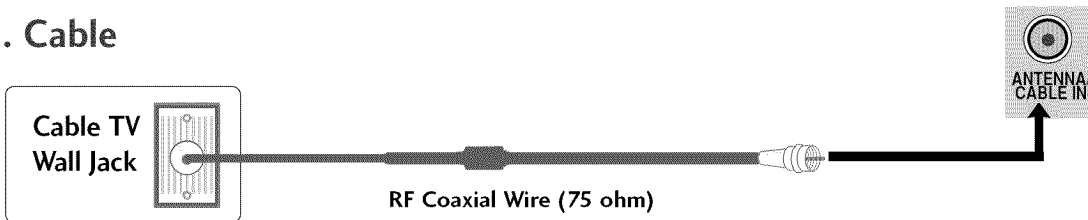

- To improve the picture quality in a poor signal area, please purchase a signal amplifier and install properly.
- If the antenna needs to be split for two TV's, install a 2-Way Signal Splitter.
- If the antenna is not installed properly, contact your dealer for assistance.
- Refer to <http://AntennaWeb.org> for more information about antennas and Digital TV.

EXTERNAL EQUIPMENT SETUP

- To prevent the equipment damage, never plug in any power cords until you have finished connecting all equipment.
- Image shown may differ from your TV.

HD RECEIVER SETUP

This TV can receive digital over-the-air/digital cable signals without an external digital set-top box. However, if you do receive digital signals from a digital set-top box or other digital external device.

Component Connection

1. How to connect

- 1 Connect the video outputs (Y, PB, PR) of the digital set-top box to the **COMPONENT IN VIDEO 1** jacks on the TV. Match the jack colors (Y = green, PB = blue, and PR = red).
- 2 Connect the audio output of the digital set-top box to the **COMPONENT IN AUDIO 1** jacks on the TV.

2. How to use

- Turn on the digital set-top box.
(Refer to the owner's manual for the digital set-top box operation.)
- Select the **Component1** input source on the TV using the **INPUT** button on the remote control.
- If connected to **COMPONENT IN 2** input, select the **Component2** input source on the TV.

Supported Resolutions

Signal	Component	HDMI
480i	Yes	No
480p	Yes	Yes
720p	Yes	Yes
1080i	Yes	Yes
1080p	Yes	Yes

Y, CB/PB, CR/PR

Resolution	Horizontal Frequency(KHz)	Vertical Frequency(Hz)
720x480i	15.73	59.94
	15.73	60.00
720x480p	31.47	59.94
	31.50	60.00
1280x720p	44.96	59.94
	45.00	60.00
1920x1080i	33.72	59.94
	33.75	60.00
1920x1080p	26.97	23.976
	27.00	24.00
	33.71	29.97
	33.75	30.00
	67.432	59.94
	67.50	60.00

EXTERNAL EQUIPMENT SETUP

LCD TV

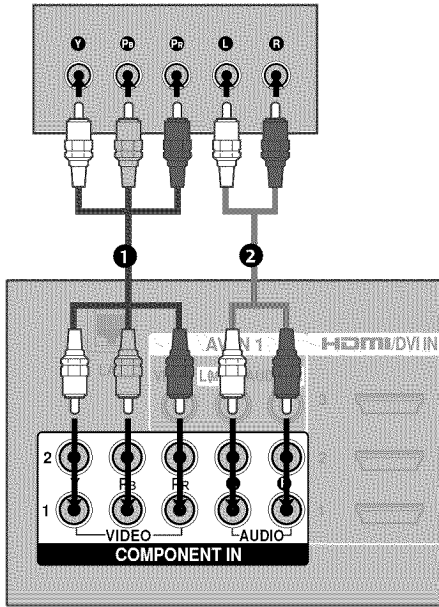

Plasma TV

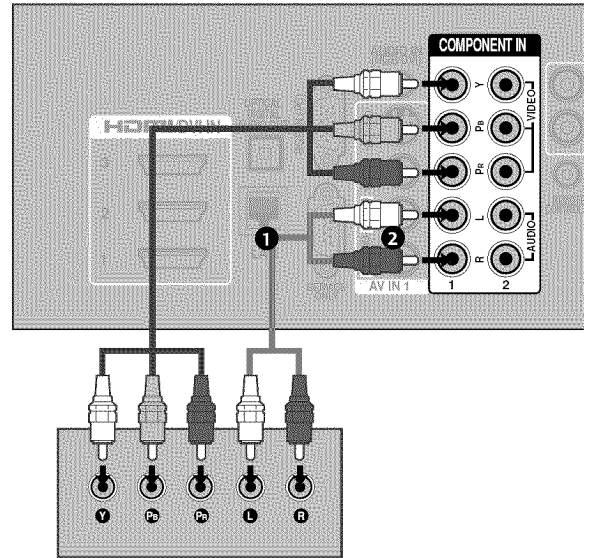

HDMI Connection

1. How to connect

- 1 Connect the digital set-top box to HDMI/DVI IN 1, 2, 3, or 4 jack on the TV.
- 2 No separate audio connection is necessary. HDMI supports both audio and video.

2. How to use

- Turn on the digital set-top box.
(Refer to the owner's manual for the digital set-top box.)
- Select the HDMI1, HDMI2, HDMI3, or HDMI4 input source on the TV using the INPUT button on the remote control.

NOTE

- ▶ Check HDMI cable over version 1.3.
If the HDMI cables don't support HDMI version 1.3, it can cause flickers or no screen display. In this case use the latest cables that support HDMI version 1.3.
- ▶ HDMI Audio Supported Format: AC3 (32KHz, 44.1KHz, 48KHz), Linear PCM (32KHz, 44.1KHz, 48KHz)

HDMI-DTV

Resolution	Horizontal Frequency(KHz)	Vertical Frequency(Hz)
720x480p	31.47	59.94
	31.50	60.00
1280x720p	44.96	59.94
	45.00	60.00
1920x1080i	33.72	59.94
	33.75	60.00
1920x1080p	26.97	23.976
	27.00	24.00
	33.71	29.97
	33.75	30.00
	67.432	59.94
	67.50	60.00

LCD TV

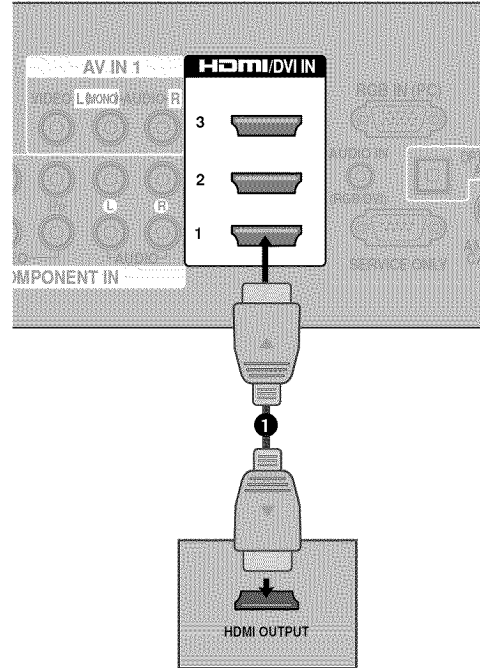

Plasma TV

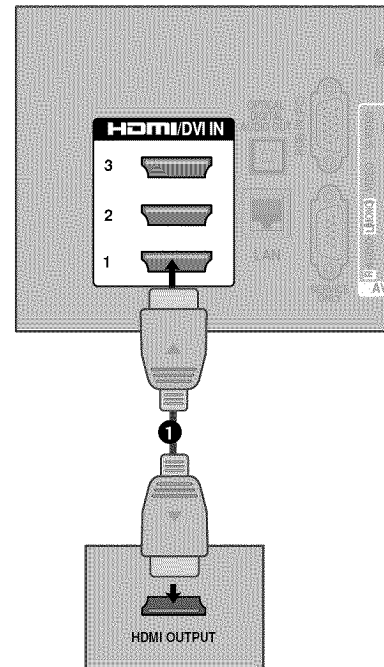

EXTERNAL EQUIPMENT SETUP

DVI to HDMI Connection

1. How to connect

- 1 Connect the DVI output of the digital set-top box to the HDMI/DVI IN 1, 2, or 3 jack on the TV.
- 2 Connect the digital set-top box audio output to the AUDIO IN (RGB/DVI) jack on the TV.

2. How to use

- Turn on the digital set-top box.
(Refer to the owner's manual for the digital set-top box.)
- Select the HDMI1, HDMI2, or HDMI3 input source on the TV using the INPUT button on the remote control.

NOTE

- ▶ A DVI to HDMI cable or adapter is required for this connection. DVI doesn't support audio, so a separate audio connection is necessary.

LCD TV

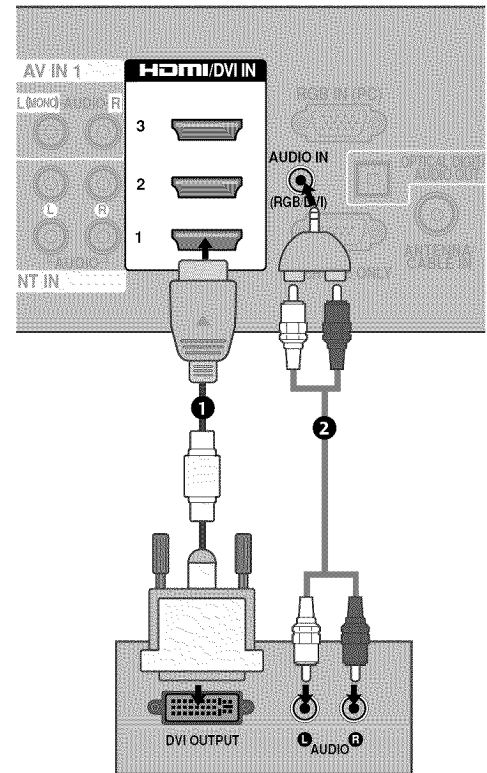

Plasma TV

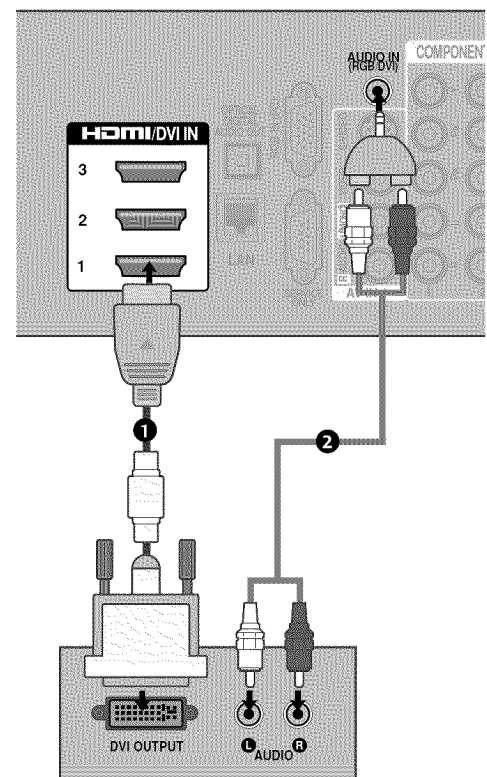

DVD SETUP

Component Connection

1. How to connect

- 1
 Connect the video outputs (Y, PB, PR) of the DVD to the **COMPONENT IN VIDEO 1** jacks on the TV.
 Match the jack colors (Y = green, PB = blue, and PR = red).

- 2
 Connect the audio outputs of the DVD to the **COMPONENT IN AUDIO 1** jacks on the TV.

2. How to use

- Turn on the DVD player, insert a DVD.
- Select the **Component1** input source on the TV using the **INPUT** button on the remote control.
- If connected to **COMPONENT IN 2** input, select the **Component2** input source on the TV.
- Refer to the DVD player's manual for operating instructions.

LCD TV

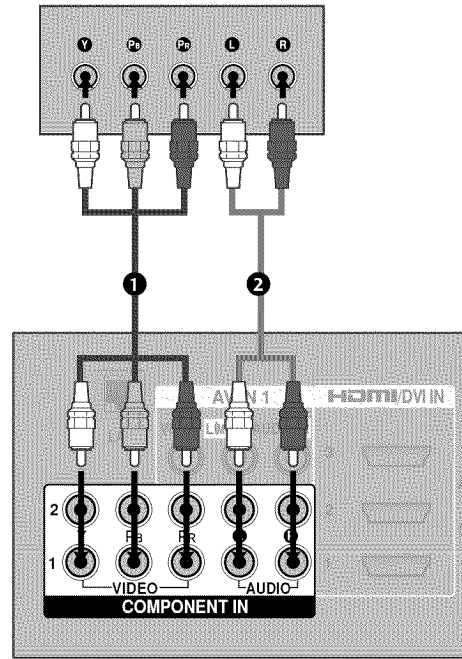

Component Input ports

To get better picture quality, connect a DVD player to the component input ports as shown below.

Component ports on the TV	Y	P _B	P _R
Video output ports on DVD player	Y	P _B	P _R
	Y	B-Y	R-Y
	Y	C _b	C _r
	Y	P _b	P _r

Plasma TV

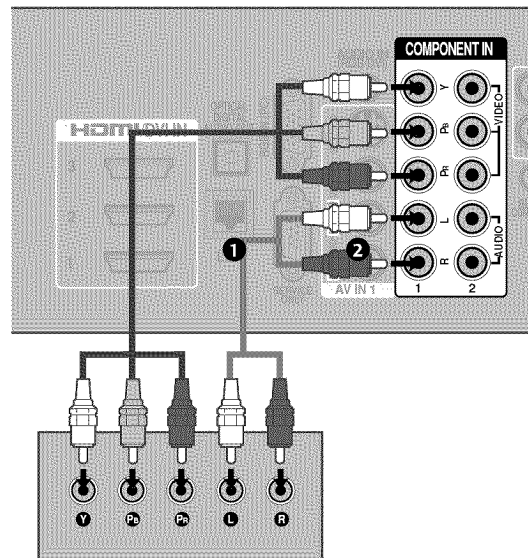

EXTERNAL EQUIPMENT SETUP

Composite (RCA) Connection

1. How to connect

- 1 Connect the **AUDIO/VIDEO** jacks between TV and DVD. Match the jack colors (Video = yellow, Audio Left = white, and Audio Right = red)

2. How to use

- Turn on the DVD player, insert a DVD.
- Select the AV1 or AV2 input source on the TV using the **INPUT** button on the remote control.
- Refer to the DVD player's manual for operating instructions.

LCD TV

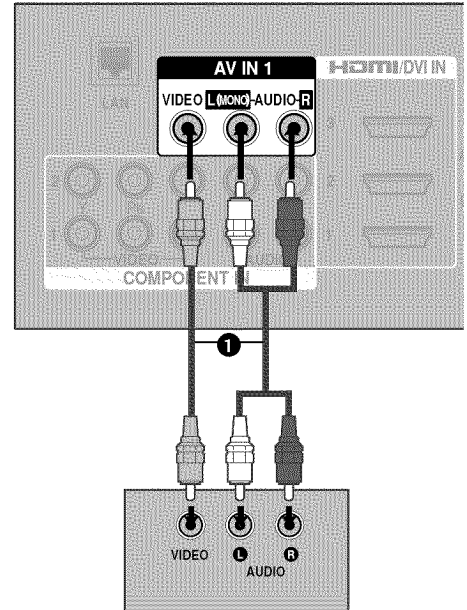

Plasma TV

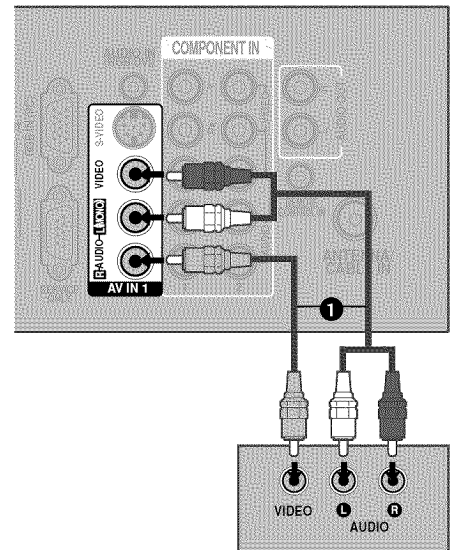

S-Video Connection (For Plasma TV)

1. How to connect

- 1 Connect the S-VIDEO output of the DVD to the S-VIDEO input on the TV.
- 2 Connect the audio outputs of the DVD to the AUDIO input jacks on the TV.

2. How to use

- Turn on the DVD player, insert a DVD.
- Select the AV 1 input source on the TV using the INPUT button on the remote control.
- Refer to the DVD player's manual for operating instructions.

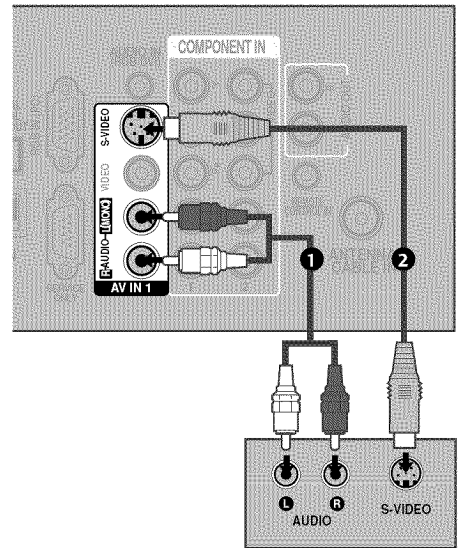

EXTERNAL EQUIPMENT SETUP

HDMI Connection

1. How to connect

- 1 Connect the HDMI output of the DVD to the HDMI/DVI IN 1, 2, 3 or 4 jack on the TV.
- 2 No separate audio connection is necessary. HDMI supports both audio and video.

2. How to use

- Select the HDMI1, HDMI2, HDMI3, or HDMI4 input source on the TV using the INPUT button on the remote control.
- Refer to the DVD player's manual for operating instructions.

NOTE

- ▶ Check HDMI cable over version 1.3. If the HDMI cables don't support HDMI version 1.3, it can cause flickers or no screen display. In this case use the latest cables that support HDMI version 1.3.

LCD TV

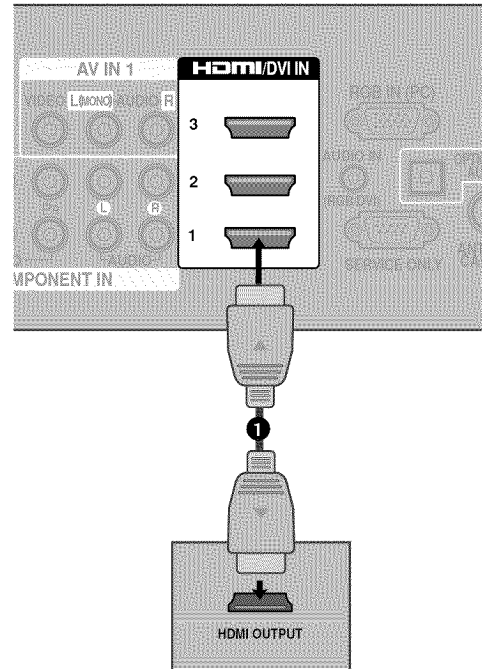

Plasma TV

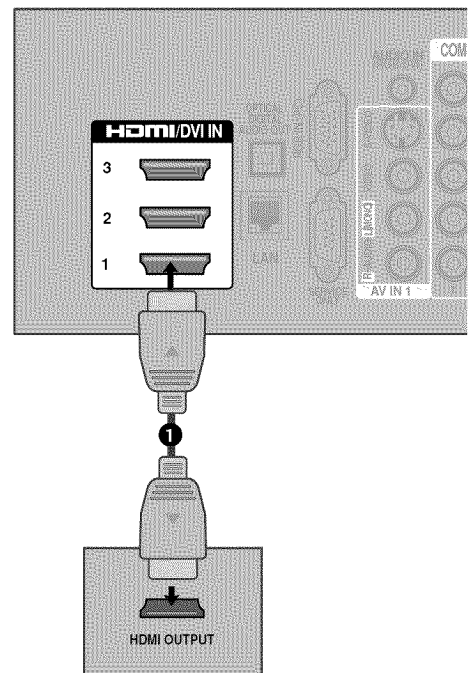

VCR SETUP

Antenna Connection

1. How to connect

- 1 Connect the RF antenna out socket of the VCR to the **ANTENNA/CABLE IN** socket on the TV.
- 2 Connect the antenna cable to the RF antenna in socket of the VCR.

2. How to use

- Set VCR output switch to 3 or 4 and then tune TV to the same channel number.
- Insert a video tape into the VCR and press **PLAY** on the VCR. (Refer to the VCR owner's manual.)

LCD TV

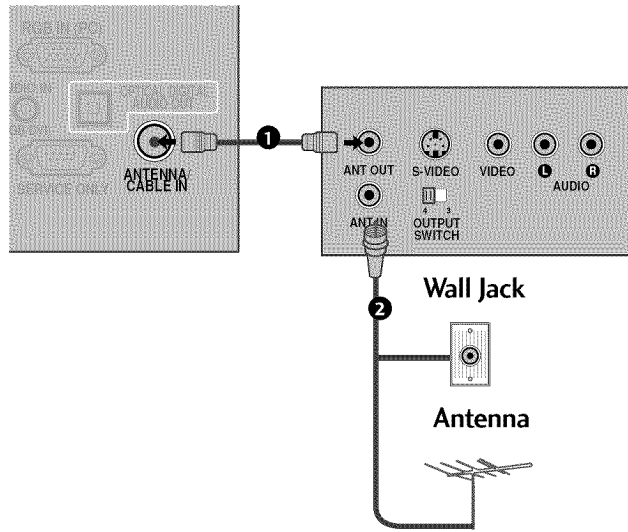

Plasma TV

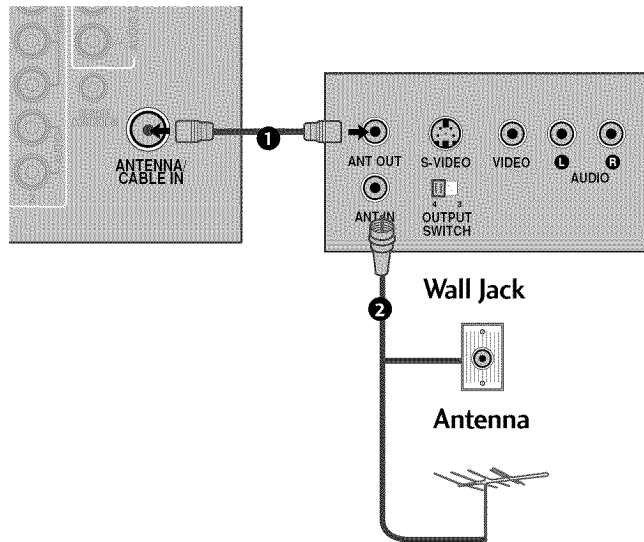

EXTERNAL EQUIPMENT SETUP

Composite (RCA) Connection

1. How to connect

- 1 Connect the **AUDIO/VIDEO** jacks between TV and VCR. Match the jack colors (Video = yellow, Audio Left = white, and Audio Right = red)

2. How to use

- Insert a video tape into the VCR and press **PLAY** on the VCR. (Refer to the VCR owner's manual.)
- Select the **AV 1** input source on the TV using the **INPUT** button on the remote control.
- If connected to **AV IN 2**, select **AV2** input source on the TV.

NOTE

- ▶ If you have a mono VCR, connect the audio cable from the VCR to the **AUDIO L/MONO** jack of the TV.

LCD TV

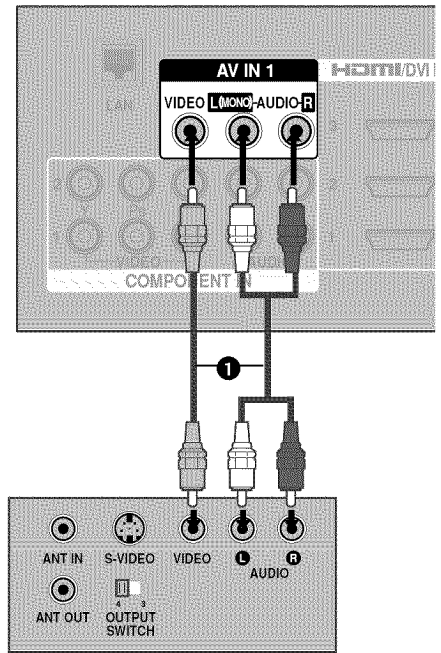

Plasma TV

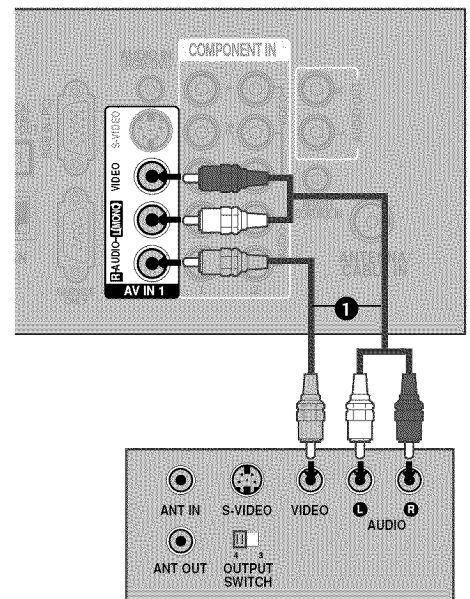

S-Video Connection (For Plasma TV)

1. How to connect

- 1 Connect the S-VIDEO output of the VCR to the S-VIDEO input on the TV.
- 2 Connect the audio outputs of the VCR to the AUDIO input jacks on the TV.

2. How to use

- Insert a video tape into the VCR and press PLAY on the VCR. (Refer to the VCR owner's manual.)
- Select the AV 1 input source on the TV using the INPUT button on the remote control.

NOTE

- ▶ S-Video provides better quality than composite. Use it when available.

CAUTION

- ▶ Do not connect to both Video and S-Video at the same time. In the event that you connect both Video and the S-Video cables, only the S-Video will work.

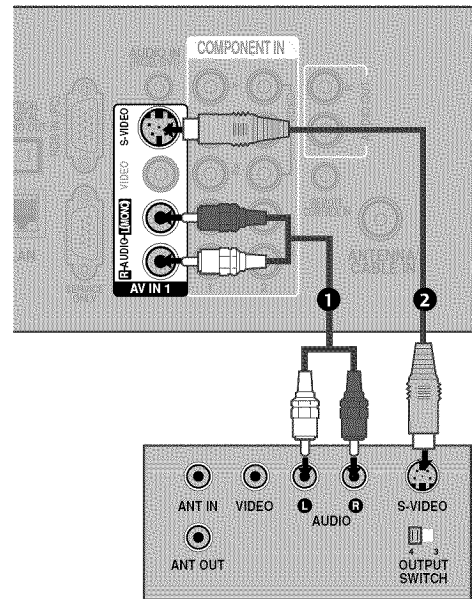

EXTERNAL EQUIPMENT SETUP

OTHER A/V SOURCE SETUP

1. How to connect

- 1 Connect the **AUDIO/VIDEO** jacks between TV and external equipment. Match the jack colors. (Video = yellow, Audio Left = white, and Audio Right = red)

2. How to use

- Select the AV2 input source on the TV using the **INPUT** button on the remote control.
- If connected to AV IN 1 input, select the AV1 input source on the TV.
- Operate the corresponding external equipment.

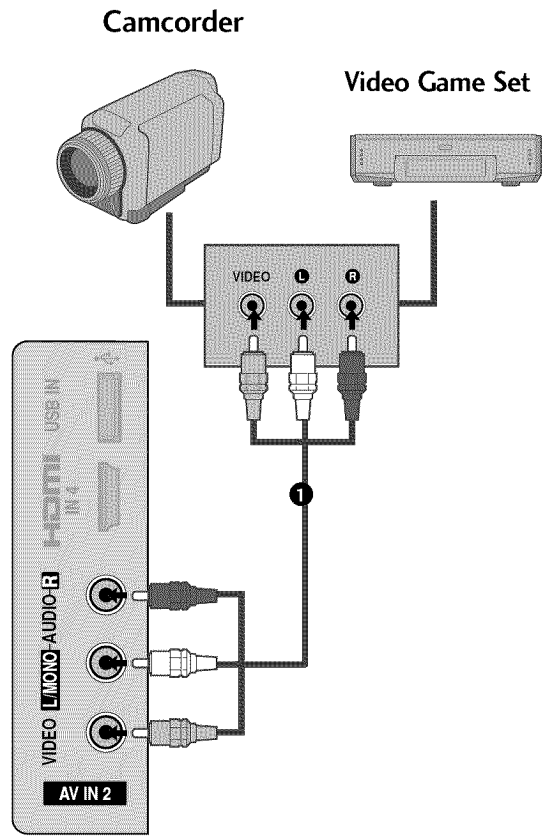

USB CONNECTION

1. How to connect

- 1 Connect the USB device to the **USB IN** jack on the side of TV.

2. How to use

- After connecting the **USB IN** jack, you use the USB function. (▶ p.90)

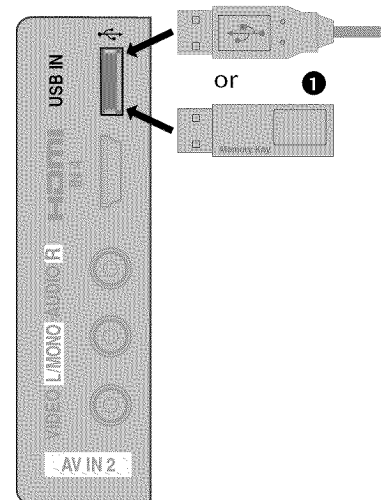

PC SETUP

This TV provides Plug and Play capability, meaning that the PC adjusts automatically to the TV's settings.

VGA (D-Sub 15 pin) Connection

1. How to connect

- 1 Connect the VGA output of the PC to the RGB IN (PC) jack on the TV.
- 2 Connect the PC audio output to the AUDIO IN (RGB/DVI) jack on the TV.

2. How to use

- Turn on the PC and the TV.
- Select the RGB-PC input source on the TV using the INPUT button on the remote control.

LCD TV

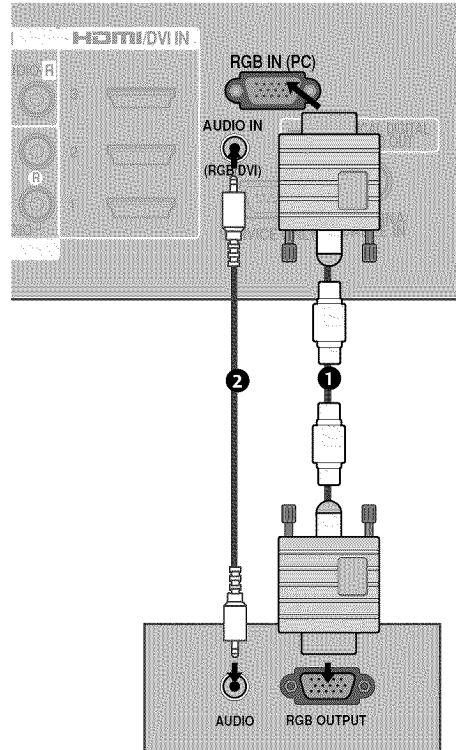

Plasma TV

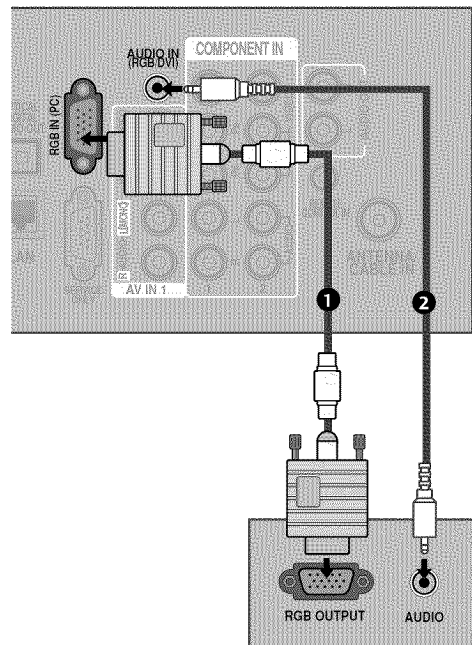

EXTERNAL EQUIPMENT SETUP

DVI to HDMI Connection

1. How to connect

- 1 Connect the DVI output of the PC to the **HDMI/DVI IN 1, 2, or 3** jack on the TV.
- 2 Connect the PC audio output to the **AUDIO IN (RGB/DVI)** jack on the TV.

2. How to use

- Turn on the PC and the TV.
- Select the **HDMI1, HDMI2, or HDMI3** input source on the TV using the **INPUT** button on the remote control.

NOTE

- ▶ Check HDMI cable over version 1.3.
If the HDMI cables don't support HDMI version 1.3, it can cause flickers or no screen display. In this case use the latest cables that support HDMI version 1.3.

LCD TV

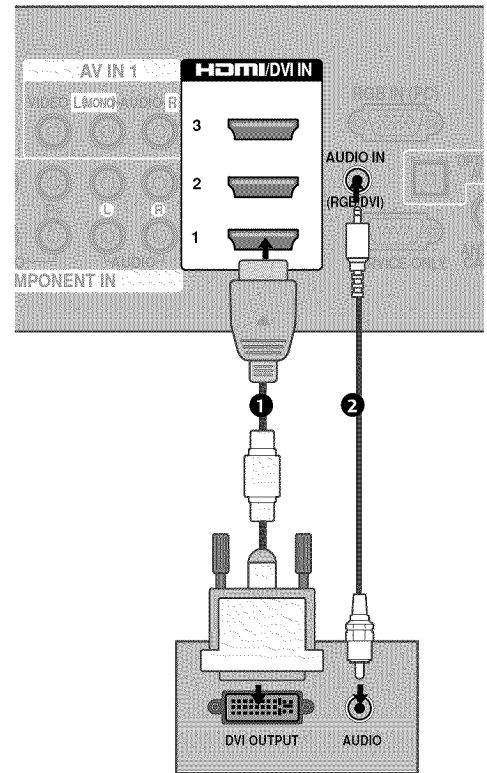

Plasma TV

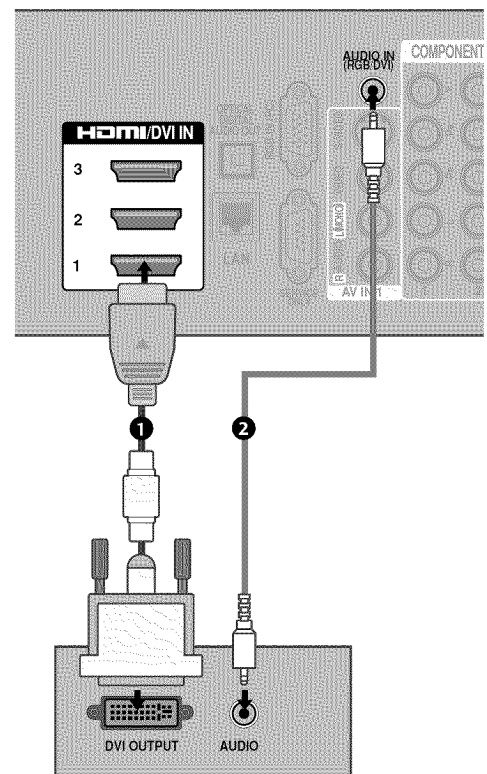

Supported Display Specifications (RGB-PC, HDMI-PC)

Resolution	Horizontal Frequency(KHz)	Vertical Frequency(Hz)
640x350	31.468	70.09
720x400	31.469	70.08
640x480	31.469	59.94
800x600	37.879	60.31
1024x768	48.363	60.00
1280x768	47.776	59.87
1360x768	47.712	60.015
1280x1024	63.981	60.02
1600x1200	75.00	60.00
1920x1080 RGB-PC	66.587	59.934
1920x1080 HDMI-PC	67.5	60.00

NOTES

- ▶ To get the the best picture quality, adjust the PC graphics card to **1920x1080**.
- ▶ Depending on the graphics card, DOS mode may not work if a HDMI to DVI Cable is in use.
- ▶ In PC mode, there may be noise associated with the resolution, vertical pattern, contrast or brightness. If noise is present, change the PC output to another resolution, change the refresh rate to another rate or adjust the brightness and contrast on the PICTURE menu until the picture is clear.
- ▶ Avoid keeping a fixed image on the screen for a long period of time. The fixed image may become permanently imprinted on the screen.
- ▶ The synchronization input form for Horizontal and Vertical frequencies is separate.
- ▶ Depending on the graphics card, some resolution settings may not allow the image to be positioned on the screen properly.
- ▶ If there are overscan in HDMI-PC 1920x1080, change aspect ratio to **Just scan**.
- ▶ When selecting HDMI-PC, set the "Input Label - PC" in the OPTION menu.

EXTERNAL EQUIPMENT SETUP

Screen Setup for PC mode





Selecting Resolution

You can choose the resolution in RGB-PC mode.

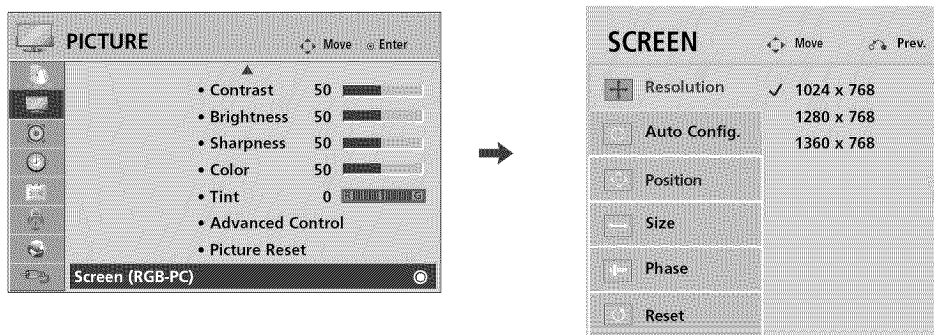
The **Position**, **Phase**, and **Size** can also be adjusted.

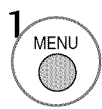
You can choose this option only when the PC resolution is set to 1024X768, 1280X768 or 1360X768.

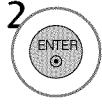
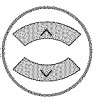
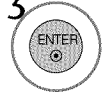
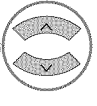
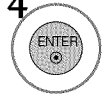
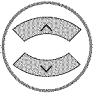







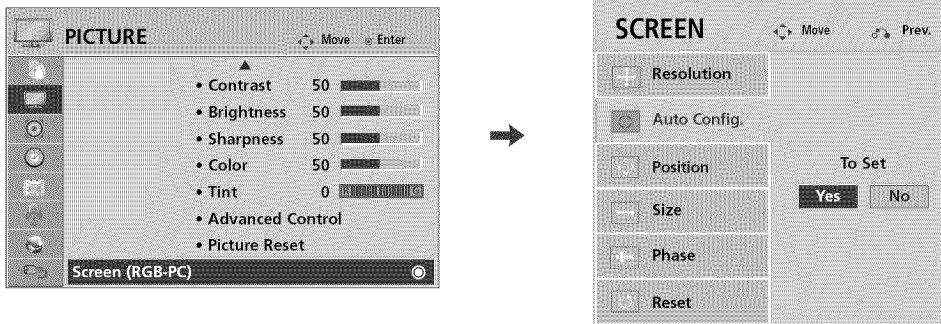

-   Select **PICTURE**.
-   Select **Screen (RGB-PC)**.
-   Select **Resolution**.
-   Select the desired resolution.
- 

Auto Configure

Automatically adjusts picture position and minimizes image instability. After adjustment, if the image is still not correct, try using the manual settings or a different resolution or refresh rate on the PC.



- 1   Select **PICTURE**.
- 2   Select **Screen (RGB-PC)**.
- 3   Select **Auto Config.**
- 4   Select **Yes**.
- 5  Start Auto Configuration.

- If the position of the image is still not correct, try Auto adjustment again.
- If picture needs to be adjusted again after Auto adjustment in RGB-PC, you can adjust the **Position**, **Size** or **Phase**.





EXTERNAL EQUIPMENT SETUP

Adjustment for screen Position, Size, and Phase

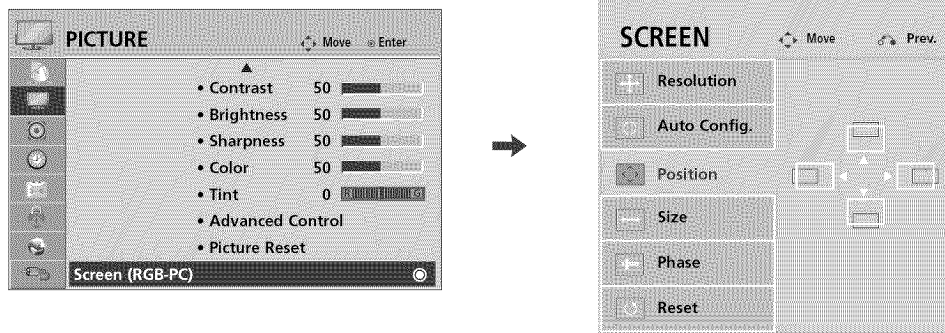
If the picture is not clear after auto adjustment and especially if characters are still trembling, adjust the picture phase manually.

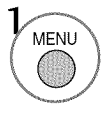
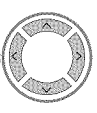
This feature operates only in RGB-PC mode.

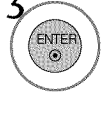
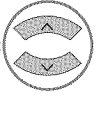
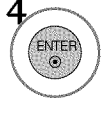

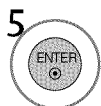







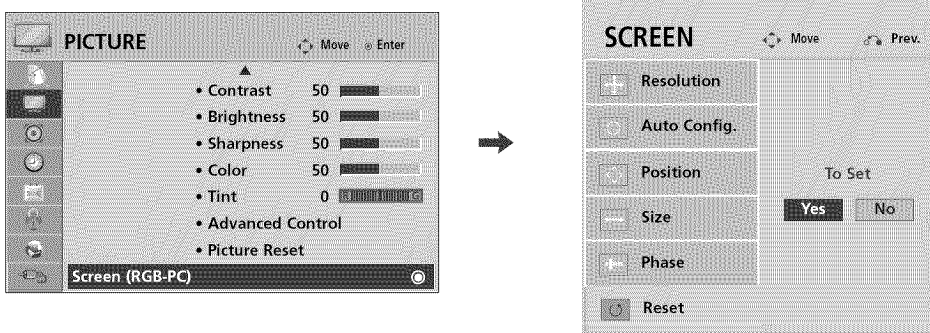

-   Select **PICTURE**.
-   Select **Screen (RGB-PC)**.
-   Select **Position, Size, or Phase**.
-   Make appropriate adjustments.
- 

- **Position:** This function is to adjust picture to left/right and up/down as you prefer.
- **Size:** This function is to minimize any vertical bars or stripes visible on the screen background. And the horizontal screen size will also change.
- **Phase:** This function allows you to remove any horizontal noise and clear or sharpen the image of characters.

Screen Reset (Reset to original initial values)

Returns **Position**, **Size**, and **Phase** to the default initial settings.
This feature operates only in RGB-PC mode.



- 1   Select **PICTURE**.
- 2   Select **Screen (RGB-PC)**.
- 3   Select **Reset**.
- 4   Select **Yes**.
- 5 

EXTERNAL EQUIPMENT SETUP

AUDIO OUT CONNECTION

Send the TV's audio to external audio equipment via the Audio Output port.

If you want to enjoy digital broadcasting through 5.1-channel speakers, connect the OPTICAL DIGITAL AUDIO OUT terminal on the back of TV to a Home Theater (or amp).

Analog (For Plasma TV)

1. How to connect

- 1 Connect audio outputs to the TV's AUDIO OUT jacks.
- 2 Set the "TV Speaker option - Off" in the AUDIO menu. (▶ p.149). See the external audio equipment instruction manual for operation.

Plasma TV

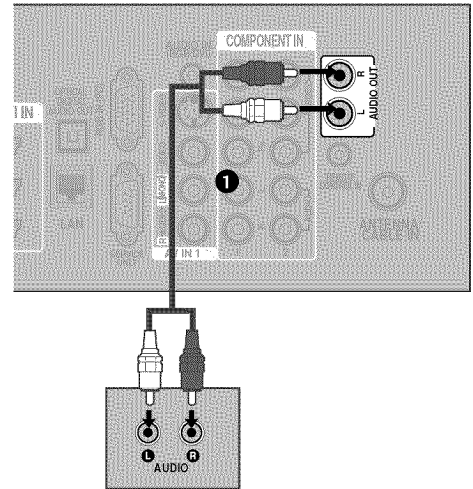

Digital

1. How to connect

- 1 Connect one end of the optical cable to the TV port of OPTICAL DIGITAL AUDIO OUT.
- 2 Connect the other end of the optical cable to the digital audio input on the audio equipment.
- 3 Set the "TV Speaker option - Off" in the AUDIO menu. (▶ p.149). See the external audio equipment instruction manual for operation.

LCD TV

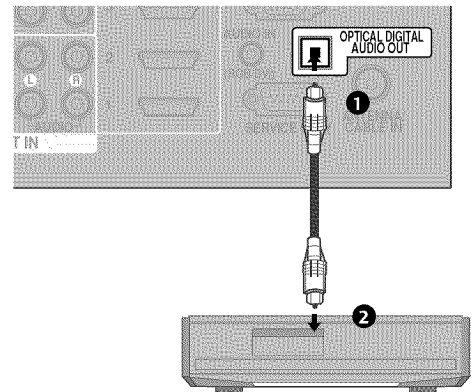

Plasma TV

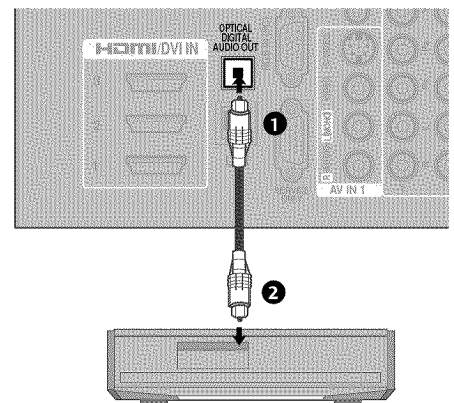

NOTE

- ▶ When connecting with external audio equipment, such as amplifiers or speakers, you can turn the TV speakers off in the menu. (▶ p.149)

CAUTION

- ▶ Do not look into the optical output port. Looking at the laser beam may damage your vision.
- ▶ Audio with ACP (Audio Copy Protection) function may block digital audio output.

NETWORK SETUP

This TV can be connected to a local area network (LAN) via the LAN port. After making the physical connection, the TV needs to be set up for network communication.

i.e) LCD TV

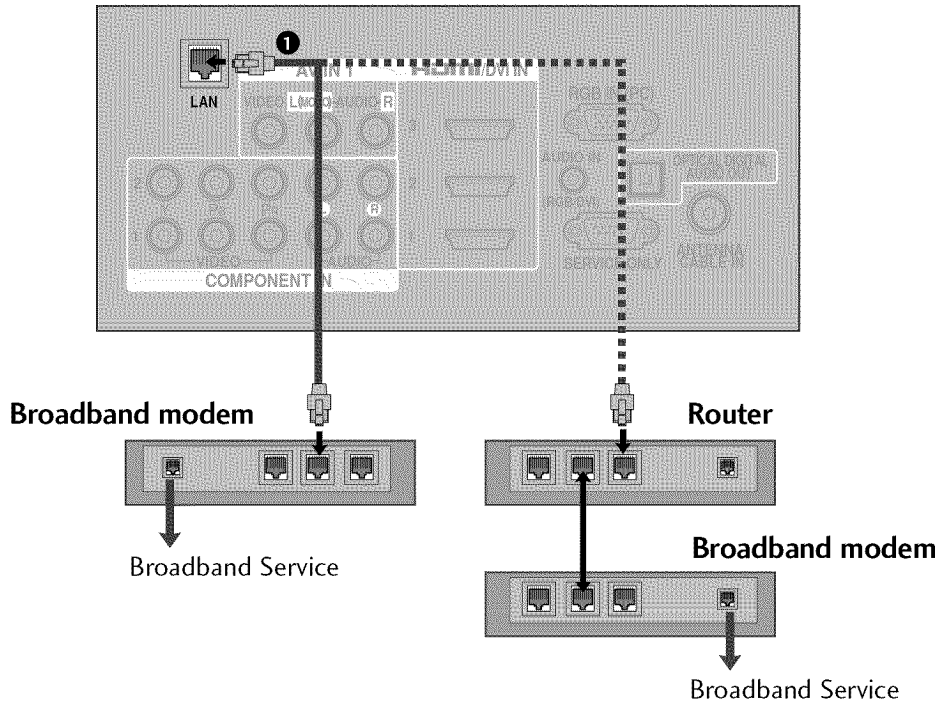

1. How to connect

- 1 Connect the LAN port of the Modem or Router to the LAN port on the TV.

2. How to use

- Select “**Network Setting - Auto Resetting**” in the NETWORK menu (▶ p.47).
- After connecting the LAN port, use the NetCast menu (Yahoo! TV Widgets, Netflix, Vudu, YouTube, My Media) (▶ p.70-127).

⚠ CAUTION

- ▶ Do not connect a modular phone cable to the LAN port.
- ▶ Since there are various connection methods, please follow the specifications of your telecommunication carrier or internet service provider.

EXTERNAL EQUIPMENT SETUP

NOTE

- ▶▶ Use a standard LAN cable with this TV. Cat5 or better with a RJ45 connector.
- ▶▶ Depending on the internet service provider (ISP), the number of devices that can receive internet service may be limited by the applicable terms of service. For details, contact your ISP.
- ▶▶ LG is not responsible for any malfunction of the TV and/or the internet connection feature due to communication errors/malfunctions associated with your broadband internet connection, or other connected equipment.
- ▶▶ LG is not responsible for problems with in your internet connection.
- ▶▶ Some content available through the network connection may not be compatible with the TV. If you have questions about such content, please contact the producer of the content.
- ▶▶ You may experience undesired results if the network connection speed does not meet the requirements of the content being accessed.
- ▶▶ Some internet connection operations may not be possible due to certain restrictions set by the Internet service provider (ISP) supplying your broadband Internet connection.
- ▶▶ Any fees charged by an ISP including, without limitation, connection charges are your responsibility.
- ▶▶ A 10 Base-T or 100 Base-TX LAN port is required for connection to this TV. If your internet service does not allow for such a connection, you will not be able to connect the TV.
- ▶▶ A DSL modem is required to use DSL service and a cable modem is required to use cable modem service. Depending on the access method of and subscriber agreement with your ISP, you may not be able to use the internet connection feature contained in this TV or you may be limited to the number of devices you can connect at the same time. (If your ISP limits sub-scription to one device, this TV may not be allowed to connect when a PC is already connected.)
- ▶▶ The use of a "Router" may not be allowed or its usage may be limited depending on the policies and restrictions of your ISP. For details, contact your ISP directly.
- ▶▶ Your ISP may protect this TV from being connected to network when confirming MAC ADDRESS. In that case, contact your ISP to request to initialize MAC ADDRESS.
- ▶▶ For personal information security, set the public folder setting of the user server PC to Read Only when using it in a public location.
- ▶▶ When you change the shared folder setting while it is in use, it may malfunction. Therefore do not change the folder setting while the folder is shared.





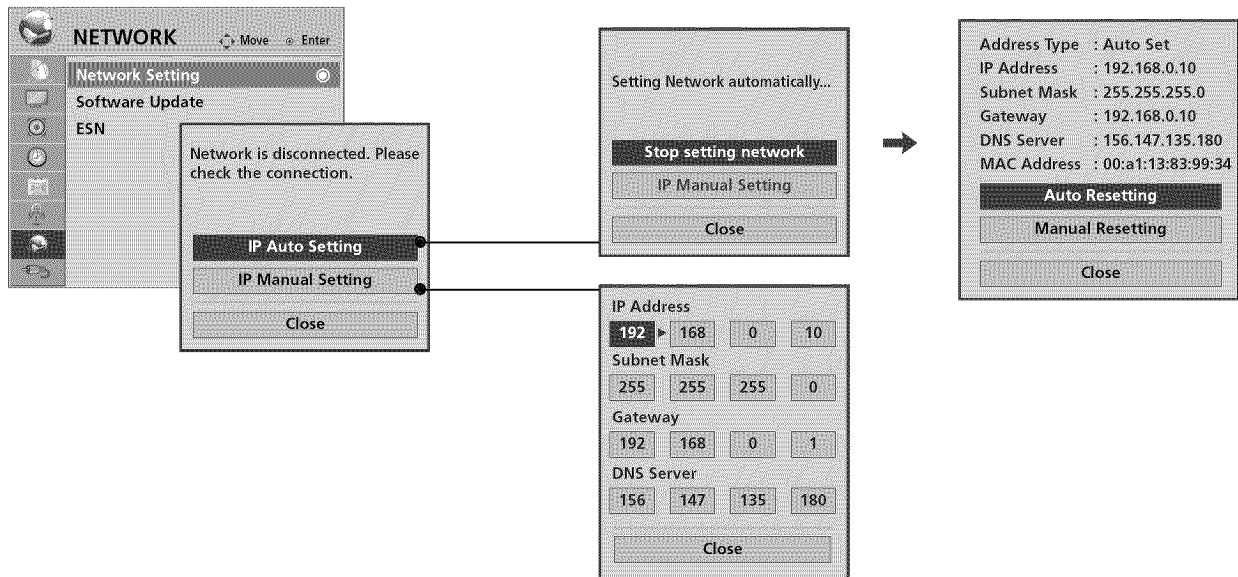

Network setting

You must run the Network setup if you wish to use the Netflix, Yahoo! TV Widgets feature, Vudu, YouTube, viewing photos/Movies and listening to MP3s (Refer to P.70-127)





If there is a DHCP server on the local area network (LAN), the TV will automatically be allocated an IP address. If you're using a broadband router or broadband modem that has a DHCP (Dynamic Host Configuration Protocol) server function, select **IP Auto Setting**. The IP address will automatically be determined.

If there is no DHCP server on the network and you want to set the IP address manually, select **IP Manual Setting**. For detail information, contact your internet provider or router manual.



- 1   Select **NETWORK**.
- 2   Select **Network Setting**.
- 3   Select **IP Auto Setting** or **IP Manual Setting**.

IP Manual Setting

- 4    Input the setting value.
- 5  Return to the previous menu.
-  Return to TV viewing.

- This feature requires an always-on broadband internet connection. You do not need to connect to a PC to use this function.
- If the **Network Setting** is not working, check your network conditions. Check the LAN cable and make sure your router has DHCP turned on if you wish to use the Auto Setting.
- If the **Network Setting** is not completed, network may not operate normally.

WATCHING TV / CHANNEL CONTROL

REMOTE CONTROL FUNCTIONS

When using the remote control, aim it at the remote control sensor on the TV.

AV MODE Toggles through preset Video and Audio modes. ▶ p.64

SIMPLINK See a list of AV devices connected to TV.
When you toggle this button, the SIMPLINK menu appears at the screen. ▶ p.66-67

POWER Turns the TV on from standby or off to standby.

INPUT Rotates through inputs.
Also switches the TV on from standby. ▶ p.62

ENERGY SAVING Adjusts the Energy Saving setting. ▶ p.138

Q.MENU Opens the list of Quick Menu options. ▶ p.54

MENU Displays the main menu or clears all on-screen displays and return to TV viewing.

INFO Displays channel information at the top of the screen.
▶ p.60

NUMBER button

— (DASH) Used to enter a program number for multiple program channels such as 2-1, 2-2, etc.

LIST Displays the channel table. ▶ p.58

FLASHBK Tunes to the last channel viewed.

COLOR BUTTON Access special functions in Yahoo! TV Widgets or optional Netcast menus.

RATIO Changes the aspect ratio. ▶ p.128

FREEZE (For Plasma TV) Freezes the current frame while viewing the TV, AV, Component, RGB-PC, or HDMI input source.

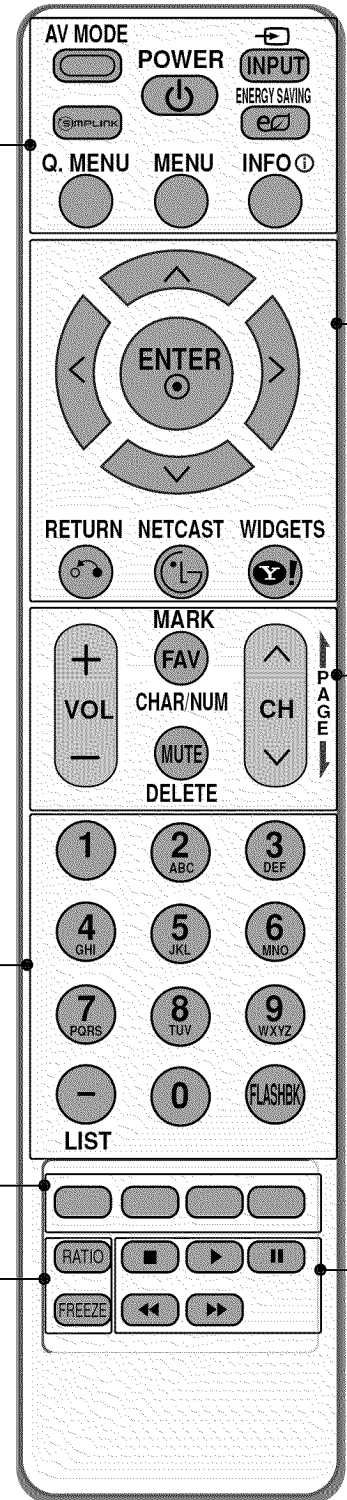

THUMBSTICK (Up/Down/Left Right/ENTER) Used to move focus around and make selections in the on-screen menus and Yahoo! TV Widgets.

RETURN Allows the user to move return one step in an interactive application or other user interaction function.

NETCAST Select the desired NETCAST menu source. (Yahoo! TV Widgets, Netflix, Vudu, YouTube, My Media)

WIDGETS WIDGETS for showing or hiding the Yahoo! Dock and accessing the Yahoo! TV Widgets user experience. ▶ p.70-77

VOLUME UP /DOWN Adjusts the volume.

FAV Scroll through the programmed Favorite channels. ▶ p.59

MARK Select the input to apply the Picture Wizard settings. ▶ p.131
Use to mark or unmark a photo/music/movie. ▶ p.94, 99, 103

CHAR/NUM Shifts the Character or Number for YouTube.

MUTE Switches the sound on or off. ▶ p.50

DELETE Deletes the character or number on the screen for YouTube.

CHANNEL UP/DOWN Changes the channel.

PAGE UP/DOWN Moves from one full set of screen information to the next one.

USB, NETFLIX, YOUTUBE, SIMPLINK Control buttons

- Controls Netflix, MY MEDIA menu (Photo List, Music List, Movie List)
- Controls the SIMPLINK compatible devices.

Installing Batteries

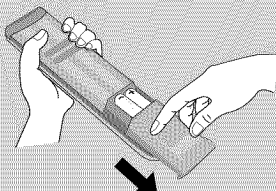

- Open the battery compartment cover on the back side and install the batteries matching correct polarity.
- Install two 1.5V AAA batteries. Don't mix old or used batteries with new ones.
- Close cover.

WATCHING TV / CHANNEL CONTROL

TURNING ON THE TV

- 1** First, connect power cord correctly.
And switch the **main power switch** on TV (For LCD TV).
At this moment, the TV switches to standby mode.
 - In standby mode to turn TV on, press the ϕ/I (For LCD TV), **INPUT, CH (▲▼)** button on the TV or press the **POWER, INPUT, CH (^ or v)**, **Number (0~9)** button on the remote control.
- 2** Select the viewing source by using the **INPUT** button on the remote control.
- 3** When finished using the TV, press the **POWER** button on the remote control. The TV reverts to standby mode.

NOTE

- ▶ If you intend to be away on vacation, disconnect the power plug from the wall power outlet.
- ▶ If you do not complete the **Initial setting**, it will appear whenever the TV is switched on until the **Initial setting** procedure is completed.
- ▶ If the TV is unplugged once or turn off with the main power switch (for LCD TV) or ϕ/I button (for Plasma TV) on the TV, reset the **Clock** function.
- ▶ If you remove power from the TV or turn off the main power switch on the TV, the **Clock** will be reset.

CHANNEL SELECTION

- 1** Press the **CH (^ or v)** or **NUMBER** buttons to select a channel number.

VOLUME ADJUSTMENT

Adjust the volume to suit your personal preference.

- 1** Press the **VOL (+ or -)** button to adjust the volume.
- 2** If you want to switch the sound off, press the **MUTE** button.
- 3** You can cancel the Mute function by pressing the **MUTE** or **VOL (+ or -)** button.

INITIAL SETTING

This Function guides the user to easily set the essential items for viewing the TV for the first time when purchasing the TV. It will be displayed on the screen when turning the TV on for the first time. It can also be activated from the user menus.

- Default selection is “**Home Use**”. We recommend setting the TV to “**Home Use**” mode for the best picture in your home environment.
- “**Store Demo**” Mode is only intended for use in retail environments. Customers can adjust the “**Picture menu - Picture mode**” manually while inspecting the TV, but the TV will automatically return to preset in-store mode after 5 minutes.
- “**Store Demo**” Mode is an optimal setting for displaying at stores. “Store Demo” mode initializes the TV to set the image quality.

Step1. Selecting Language

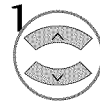
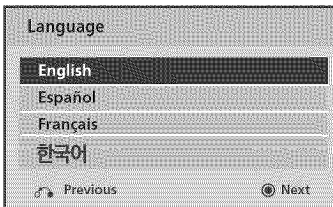

1 Select Menu Language.

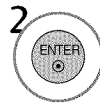

Step2. Mode setting

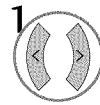



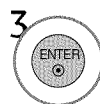

1 Select Home Use.



WATCHING TV / CHANNEL CONTROL



Step3. Time setting

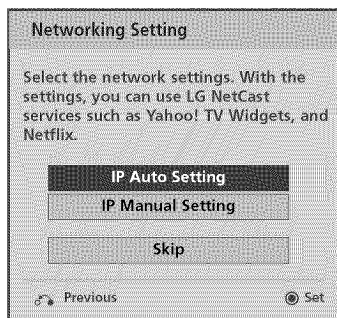

- 1  Select **Auto** or **Manual**.
- 2    Select desired time option.

Step4. Network Setting



- 1   Select **IP Auto Setting**.
When selecting **IP Manual Setting**, refer to P.47
- 2  Setting Network is completed.

Step5. Auto Tuning

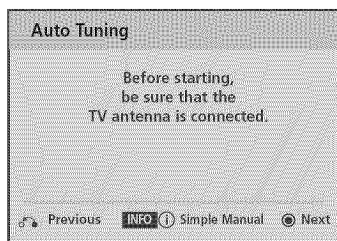

- 1  Check your antenna connection and start **Auto Tuning**.





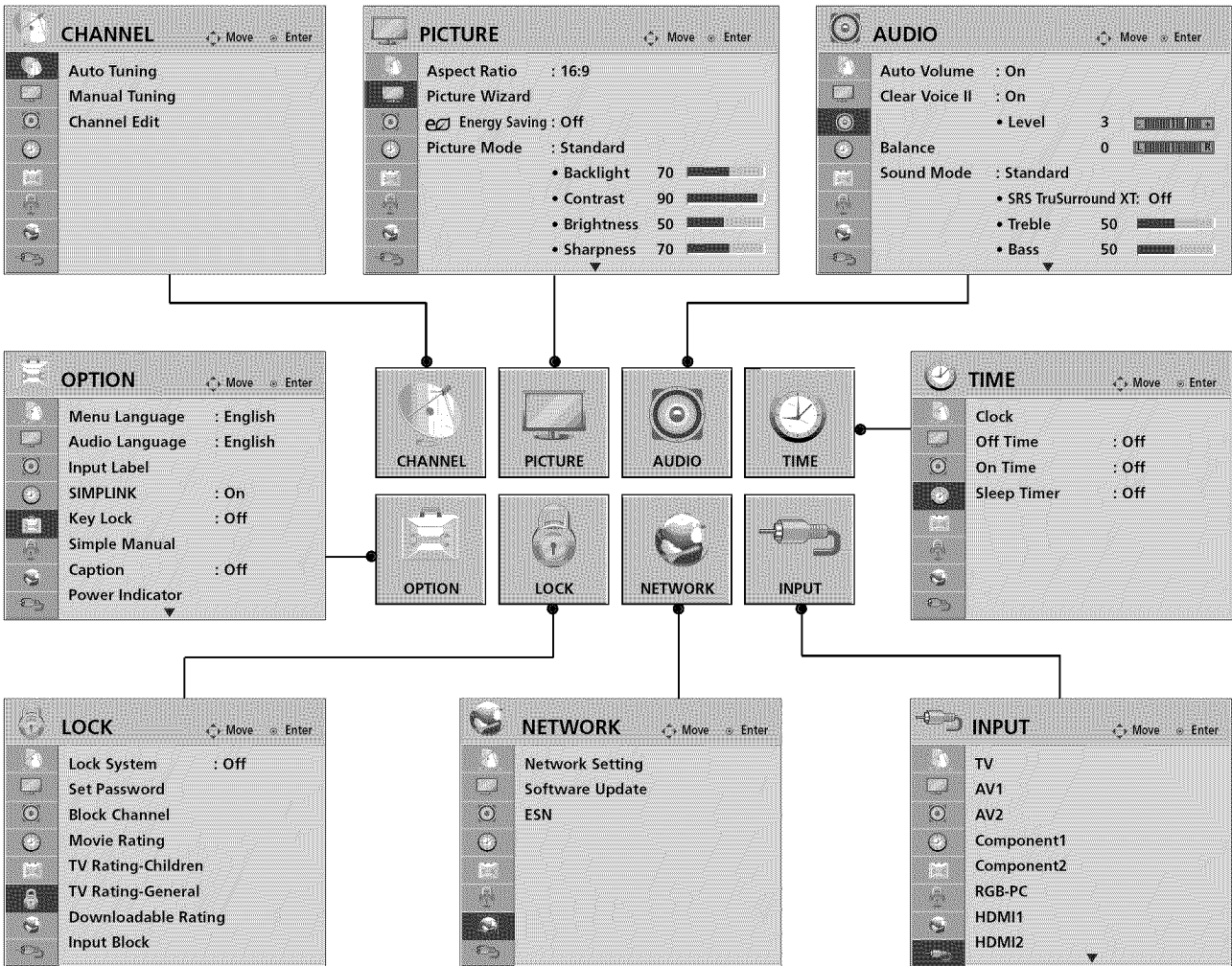

NOTE

- You can also adjust **Initial Setting** in the **OPTION** menu.

ON-SCREEN MENUS SELECTION

Your TV's OSD (On Screen Display) may differ slightly from that shown in this manual.



- 1   Display each menu.
- 2   Select a menu item.
- 3  Accept the current selection.
- 4  Return to TV viewing.

NOTE

- ▶ ISM Method, ~~IFX~~ Cinema: Only Plasma TV.
- ▶ Backlight, Power Indicator: Only LCD TV.







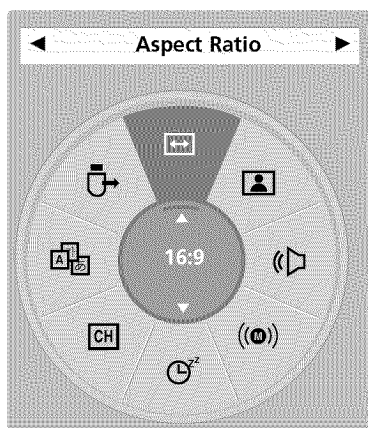

WATCHING TV / CHANNEL CONTROL

QUICK MENU

Your TV's OSD (On Screen Display) may differ slightly from what is shown in this manual.

Q.Menu (Quick Menu) is a menu of features which users might use frequently.



-  **Aspect Ratio:** Selects your desired picture format.
-  **Picture Mode:** Selects the desired preset picture setting.
-  **Sound Mode:** Selects the desired preset sound setting.
-  **Multi Audio:** Changes the audio language (Digital signal).
-  **SAP:** Selects MTS sound (Analog signal).
-  **Sleep Timer:** Select the amount of time before your TV turns off automatically.
-  **Del/Add/Fav:** Select channel you want to add/delete or add the channel to the Favorite List.
-  **Caption:** Select on or off.
-  **USB Device:** Select "Eject" in order to eject a USB device.

1   Display each menu.

2  Make appropriate adjustments.

3  Return to TV viewing.

CHANNEL SETUP





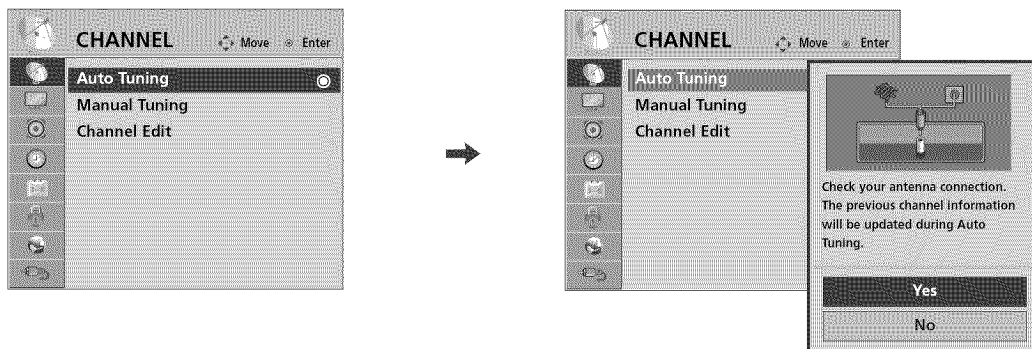

Auto Scan (Auto Tuning)

Automatically finds all channels available through antenna or cable inputs, and stores them in memory on the channel list.

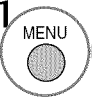
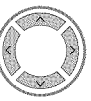
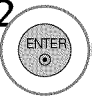
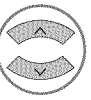
Run this function if you change your residence or move the TV. Also, make sure to run this function with the antenna connected during TV broadcasting hours.

Auto Tuning memorizes only the channels available at the time.



- 1   Select **CHANNEL**.
- 2   Select **Auto Tuning**.
- 3   Select **Yes**.
- 4  Run **Auto tuning**.
- 5  Return to the previous menu.
-  Return to TV viewing.









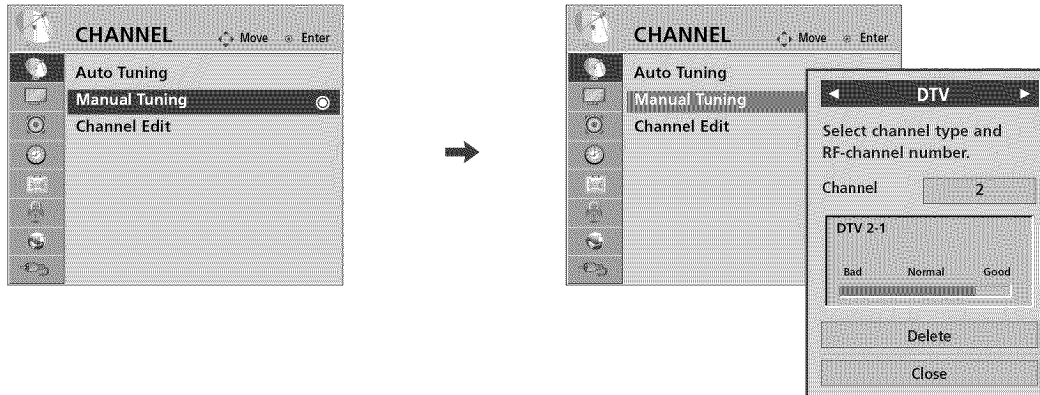



- The TV will ask for a password if parental control has been activated (LOCK Menu). Use the password you set up in the LOCK Menu to allow a channel search.
- When setting the Auto tuning or Manual tuning, the number of maximum channels you can store is 1000. It is subject to change depending on the broadcasting signal environment.
- Memorizes all the available channels in the order of DTV, TV, CADTV and CATV.

WATCHING TV / CHANNEL CONTROL

Add/Delete Channel (Manual Tuning)

When selecting DTV or CADTV input signal in the Manual Tuning menu, you can view the on-screen signal strength monitor to see the quality of the signal being received.



- 1   Select **CHANNEL**.
- 2   Select **Manual Tuning**.
- 3   Select **DTV, TV, CADTV, or CATV**.
- 4   Select channel you want to add or delete.
- 5   Select **Add or Delete**.
- 6  Return to the previous menu.
-  Return to TV viewing.

- The TV will ask for a password if parental control has been activated (LOCK Menu). Use the password you set up in the LOCK Menu to allow a channel search.
- When setting the Auto tuning or Manual tuning, the number of maximum channels you can store is 1000. It is subject to change depending on the broadcasting signal environment.







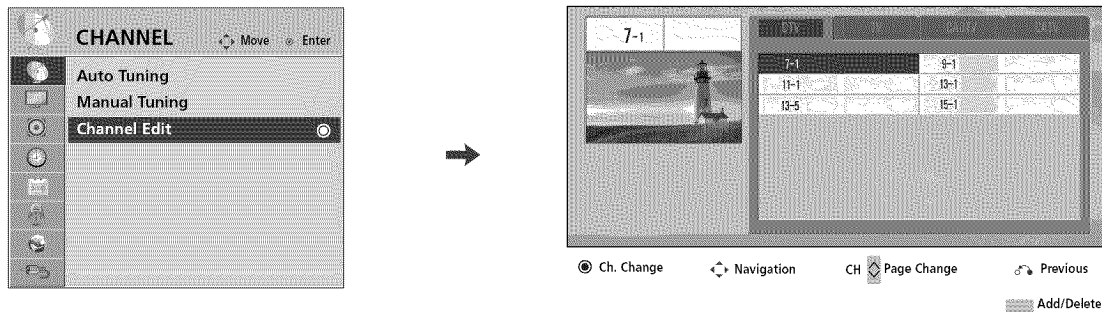

Channel Editing

The channels in the Channel Edit List are displayed in black and the channels deleted from the Channel Edit List are displayed in blue.

When a channel number is deleted, it means that you will be unable to select it using CH \wedge \vee button during TV viewing.

If you wish to select the deleted channel, directly enter the channel number with the NUMBER buttons or select it in the **Channel Edit** menu.



- 1   Select **CHANNEL**.
- 2   Select **Channel Edit**.
- 3   Select a channel.
- 4  Add or delete a channel.
- 5  Return to the previous menu.
-  Return to TV viewing.

- Keep pressing the \wedge button and use the \lt or \gt buttons to move between DTV, TV, CADTV and CATV.
- If the channel list is too long, use the CH \wedge or \vee button to move between pages.

WATCHING TV / CHANNEL CONTROL

CHANNEL LIST

You can check which channels are stored in the memory by displaying the channel list.

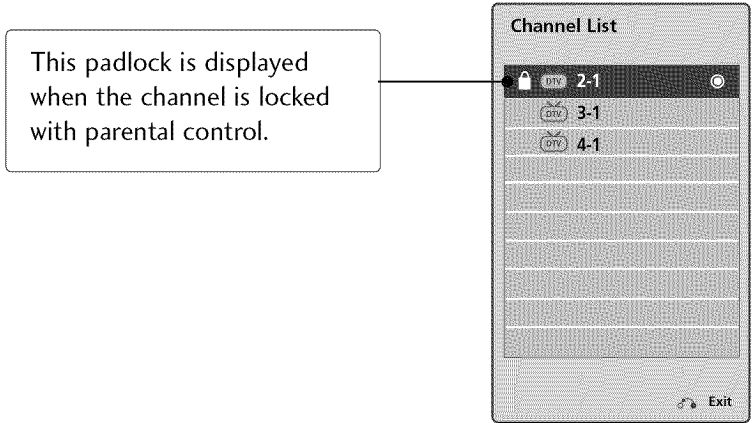



Displaying Channel List

- 1  Display the Channel List.

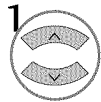
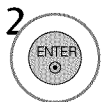
Selecting a channel in the channel list

- 1  Select a channel.
- 2  Switch to the chosen channel number.

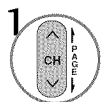
Paging through a channel list



- 1  Turn the pages.
- 2  Return to TV viewing.

FAVORITE CHANNEL SETUP

Favorite Channels are a convenient feature that lets you quickly select channels of your choice without waiting for the TV to select all the in-between channels.

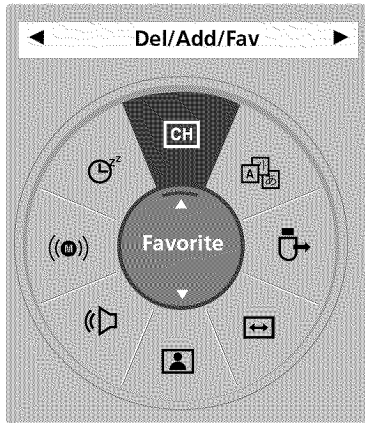
To tune to a favorite channel, press the FAV (Favorite) button repeatedly.

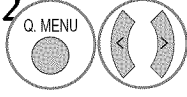

- 1  Select your desired channel.
- 2  Select Del/Add/Fav.
- 3  Select Favorite.
- 4  Return to TV viewing.

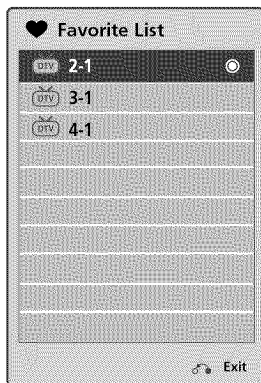

FAVORITE CHANNEL LIST





Displaying the favorite channel list

- 1  Display the Favorite channel list.

Selecting a channel in the favorite channel list

- 1  Select a channel.
- 2  Switch to the chosen channel number.

Paging through a favorite channel list

- 1  Turn the pages.
- 2  Return to TV viewing.

WATCHING TV / CHANNEL CONTROL





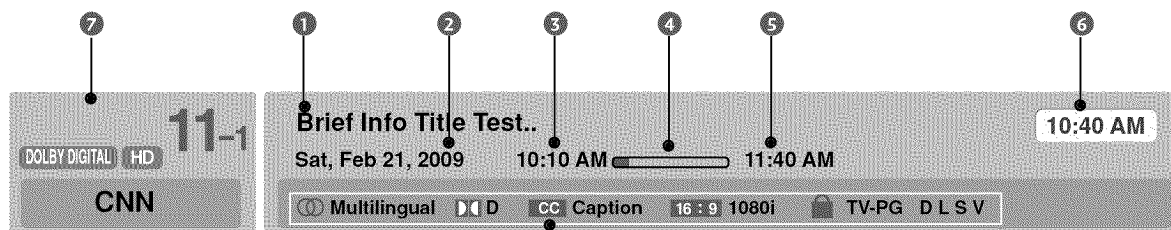

BRIEF INFORMATION

Brief Info shows the present screen information.

1  Show the Brief Info on the screen.

2  Return to TV viewing.







	Multilingual : The program contains two or more audio services. Use the Q.MENU menu to select wanted Audio.
	Caption : The program contains one or more caption services. Use the Q.MENU menu to select wanted Closed caption.
	Dolby Digital : The program contains a Dolby Digital audio signal in TV and HDMI input source.
	4:3 The original aspect ratio of the video is 4:3 16:9 The original aspect ratio of the video is 16:9 (wide)
	480i The video resolution is 720x480i 480p The video resolution is 720x480p 720p The video resolution is 1280x720p 1080i The video resolution is 1920x1080i 1080p The video resolution is 1920x1080p
	V-Chip : The program contains V-Chip information. Refer to the LOCK menu: A (Age), D (Dialogue), L (Language), S (Sex), V (Violence), FV (Fantasy Violence)

- 1 Program title
- 2 Day, Month, Year
- 3 Program start time
- 4 Program progress bar
- 5 Program finish time
- 6 Present time
- 7 Banner information

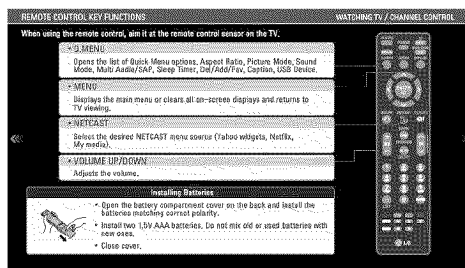
SIMPLE MANUAL

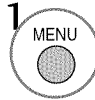
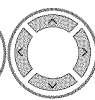
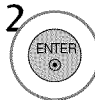
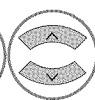
You can easily and effectively access the TV information by viewing a simple manual on the TV. During the Simple Manual operation, audio will be muted.

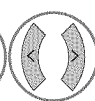

-   Select **OPTION**.
-   Select **Simple Manual**.
-   Select the part of the manual you want to see.
-  Return to TV viewing.

WATCHING TV / CHANNEL CONTROL

INPUT LIST

Only these input signals which are connected to a TV can be activated and selected.

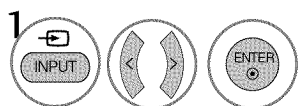

1 Select the desired input source.

■ You can also select the desired input source in the **INPUT** menu.

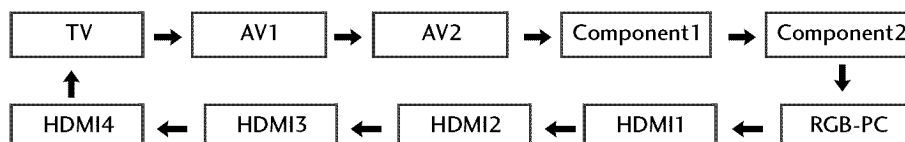

ie)

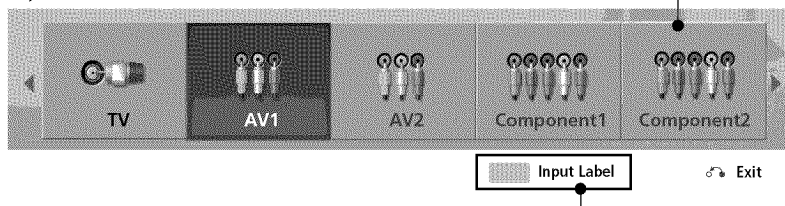

Disconnected inputs are inactive (grayed out)

Select a desired input source (except TV). Then, you can select your desired **Input Label** with using Blue button. ▶ p.63

ie) In case of changing the input label using Blue button

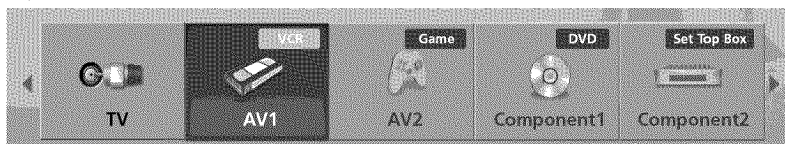

- When new external device is connected, this popup menu is displayed automatically.
If selecting **Yes**, you can select input source that you want to appreciate.
- But, when selecting "SIMPLINK - On", popup menu for HDMI input will not be displayed.

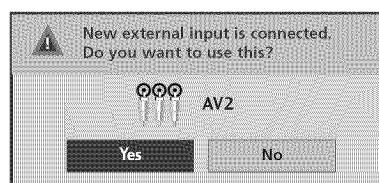







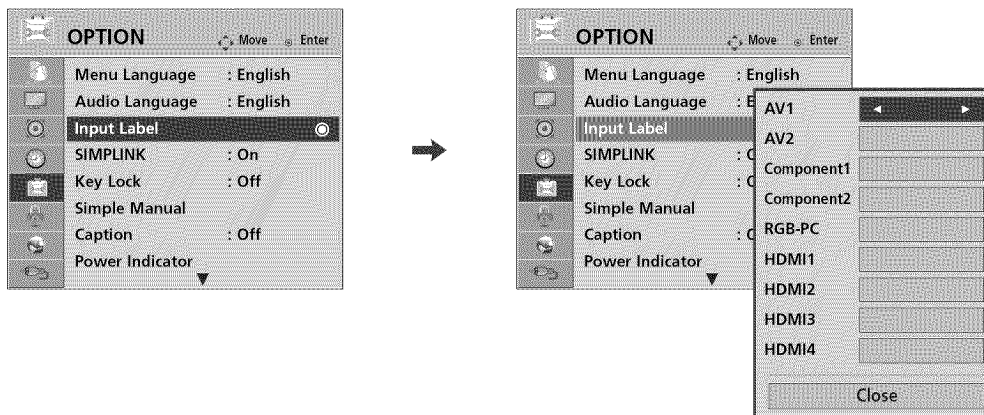

- **TV**: Select it to watch over-the-air, cable and digital cable broadcasts.
- **AV**: Select them to watch a VCR or other external equipment.
- **Component**: Select them to watch DVD or a Digital set-top box.
- **RGB-PC**: Select it to view PC input.
- **HDMI**: Select them to watch high definition devices.

INPUT LABEL







You can set a label for each input source when it's not in use.
This indicates which device is connected to which input port.



With using OPTION menu

- 1   Select **OPTION**.
- 2   Select **Input Label**.
- 3   Select the source.
- 4  Select the label.
- 5  Return to the previous menu.
-  Return to TV viewing.

With using INPUT button

- 1   Select the source.
- 2   Select the label.
- 3  Return to the previous menu.
-  Return to TV viewing.

WATCHING TV / CHANNEL CONTROL

AV MODE

AV Mode toggles through preset Video and Audio settings.

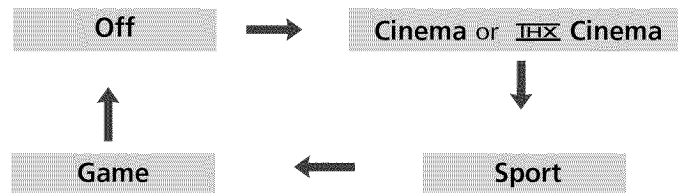

1



Press the **AV MODE** button repeatedly to select the desired source.

2









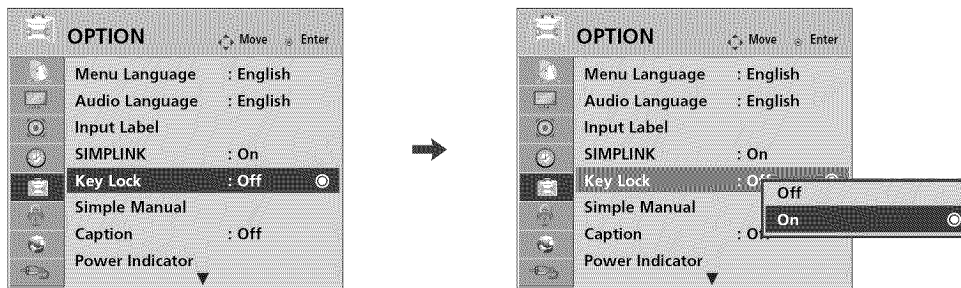

- If you select “**Cinema / THX Cinema**” in AV mode, **Cinema** will be selected both for “**PICTURE** menu - **Picture Mode**” and “**AUDIO** menu - **Sound Mode**” respectively.
- If you select “**Off**” in AV mode, the “**Picture Mode**” and “**Sound Mode**” return to previous selected value.
- **Off**: Disables the AV MODE.
- **Cinema**: Optimizes video and audio for watching movies.
- **Sport**: Optimizes video and audio for watching sports events.
- **Game**: Optimizes video and audio for playing games.

KEY LOCK

This feature can be used to prevent unauthorized viewing by locking out the front panel controls, so that it can only be used with the remote control.

This TV is programmed to remember which option it was last set to even if you turn the TV off.



- 1   Select **OPTION**.
- 2   Select **Key Lock**.
- 3   Select **On** or **Off**.
- 4  Return to the previous menu.
-  Return to TV viewing.

- In **Key Lock 'On'**, if the TV is turned off, press the ϕ / I, **INPUT, CH** (\blacktriangle \blacktriangledown or \blacktriangle \blacktriangledown) button on the TV or **POWER, INPUT, CH** (\wedge \vee) or **NUMBER** buttons on the remote control.
- With the **Key Lock On**, the display **'▲ Key Lock'** appears on the screen if any button (Plasma TV: Except ϕ / I button) on the front panel is pressed while viewing the TV.





WATCHING TV / CHANNEL CONTROL

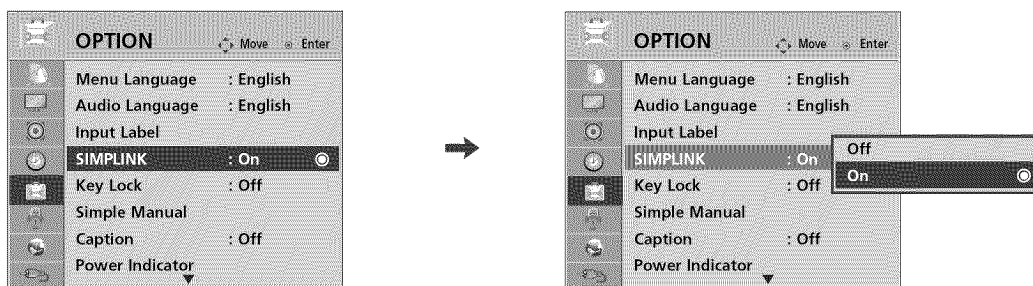

SIMPLINK allows you to control and play other AV devices connected with HDMI cable without additional cables and settings. This TV may work with devices with HDMI-CEC support, but only devices with the SIMPLINK logo are fully supported.

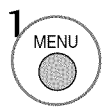
SIMPLINK can be turned on and off in the user menus.

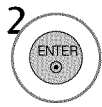
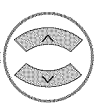
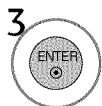
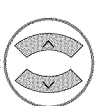

-   Select **OPTION**.
-   Select **SIMPLINK**.
-   Select **On** or **Off**.
-  Return to the previous menu.
-  Return to TV viewing.

NOTE

- ▶ Connect the HDMI/DVI IN or HDMI IN terminal of the TV to the rear terminal (HDMI terminal) of the SIMPLINK device with the HDMI cable.
- ▶ When you switch the Input source with the INPUT button on the remote control, the SIMPLINK device will stop.
- ▶ When you select a device with home theater functionality, the sound output automatically switches to the home theater speakers and the TV speakers are turned off.
- ▶ If a connected SIMPLINK home theater system doesn't play the audio from the TV, connect the DIGITAL AUDIO OUT terminal on the back of the TV to the DIGITAL AUDIO IN terminal on the back of the SIMPLINK device with an OPTICAL cable.

SIMPLINK Functions

- **Direct Play:** After connecting AV devices to the TV, you can directly control the devices and play media without additional settings.
- **Select AV device:** Enables you to select one of the AV devices connected to the TV.
- **Disc playback:** Control connected AV devices by pressing the \wedge \vee \lt \gt , ENTER, \blacktriangleright , \blacksquare , II , \blacktriangleleft and \blacktriangleright buttons.
- **Power off all devices:** When you power off the TV, all connected devices are turned off.
- **Switch audio-out:** Offers an easy way to switch audio-out.
- **Sync Power on:** When the equipment with Simplink function connected HDMI terminal starts to play, The TV will automatically turn on.

Note: To operate SIMPLINK, an HDMI cable over Version 1.3 with *CEC function should be used. (*CEC: Consumer Electronics Control).

(A device, which is connected to the TV through a HDMI cable but does not support SIMPLINK, does not provide this function)

SIMPLINK Menu

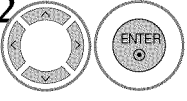
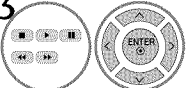
- 1  Display SIMPLINK menu.
- 2  Select the desired device.
- 3  Control connected AV devices.

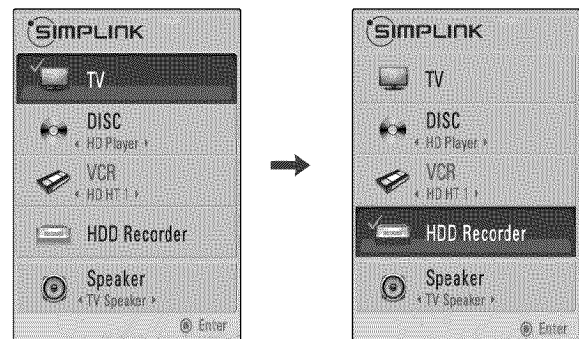

- 1 **TV viewing:** Switch to the previous TV channel regardless of the current mode.
- 2 **DISC playback:** Select and play discs. When multiple discs are available, the titles of discs are conveniently displayed at the bottom of the screen.
- 3 **VCR playback:** Control the connected VCR.
- 4 **HDD Recordings playback:** Control recordings stored in HDD.
- 5 **Audio Out to Home Theater speaker/Audio Out to TV:** Select Home Theater speaker or TV speaker for Audio Out.

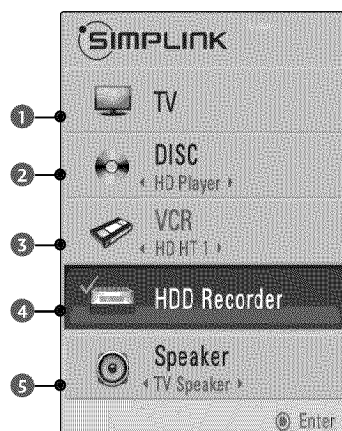

- ▶ When no device is connected (displayed in gray)
- ▶ Selected Device
- ▶ When a device is connected (displayed in bright color)

NETWORK

SOFTWARE UPDATE

You can update the TV with the latest software to enhance the product operation and/or add new features. You can update the software by connecting the TV directly to the software update server. The Software Update function may not work properly depending on your internet environment. In this case, you can obtain the latest software from the authorized LG Electronics Service Center then update your TV.

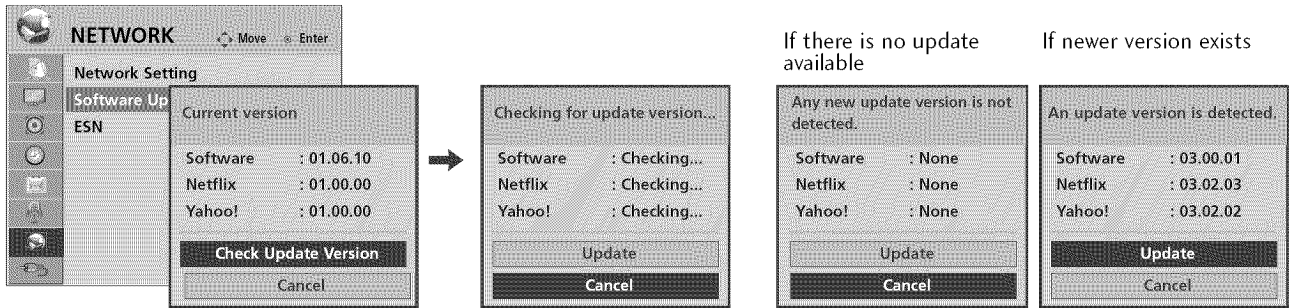

NETWORK

- 1 Select **NETWORK**.
- 2 Select **Software Update**.
- 3 Select **Check Update Version** to check the newest version.
- 4 Select **Update** if newer version exists.
- 5 Return to the previous menu.
- Return to TV viewing.

- During the software update procedure, do not turn off the TV or disconnect AC power, or do not press any button, or disconnect the LAN cable.
- If you cancel the update, disconnect AC power and turn it on for stable performance.
- This TV cannot be updated to previous software version.
- After software update, you can confirm the update software version at software Update menu.
- When update is completed, the TV will restart automatically in 5 seconds.
- The TV function may be improved or changed by software update.
- The software downloading time will vary depending on the software size and network conditions. When using a 5Mbps Cable Internet connection, software updates will download in about 3 minutes.
- The available time or functionality of NetCast menu may be depends on your ISP network conditions.
- When an update is completed, some CHANNEL, PICTURE, and AUDIO menu settings may need to resetting.

Software Update Notice

- Your TV's OSD (On Screen Display) may differ slightly from that shown in this manual.
- If the TV is connected to the internet and it finds a software update on the LG server, the software update popup menu will appear automatically.
- You can download the latest owner's manual from our Web site (<http://lgusa.com>).

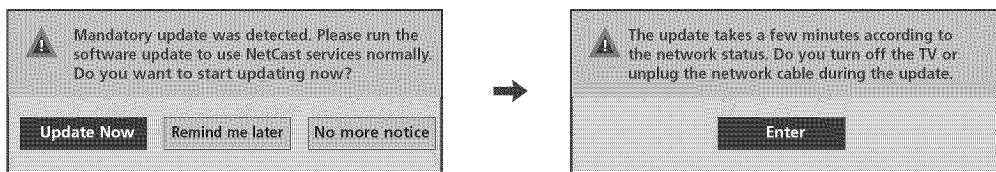



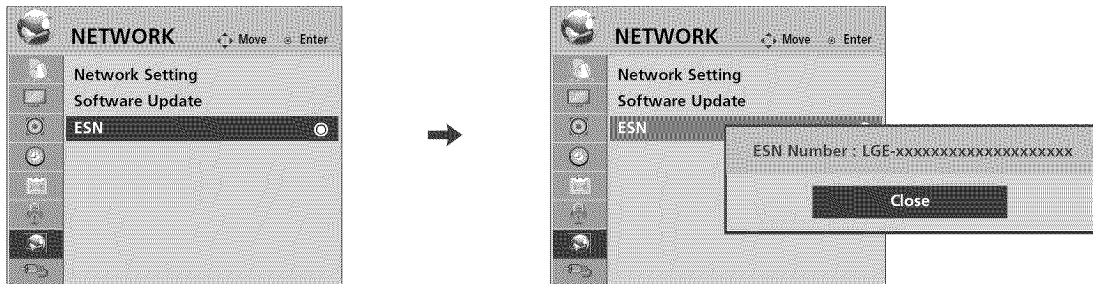

NETFLIX ESN (ELECTRONIC SERIAL NUMBER)

We provide you the Netflix ESN (Electronic Serial Number) that allows you to watch videos using the Netflix website.

For more information, please visit: www.netflix.com



-   Select **NETWORK**.
-   Select **ESN**.
-  See the ESN serial number.

NETCAST

YAHOO! TV WIDGETS

You can enjoy the best of the Internet in perfect harmony with the simplicity and reliability of your TV.









Yahoo! TV Widgets provide an integrated Internet TV experience powered by the Yahoo!® Connected TV platform. You can monitor financial stocks, share photos with friends and family, track news and weather and much more, all through the Yahoo! TV Widgets service on your TV.

Note that these services are provided by the Content Provider, using Yahoo! Widget Platform provided by Yahoo!. All the services are dependent on appropriate Content Provider. Please check about page of each widgets for Terms of service.

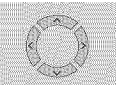
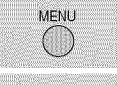
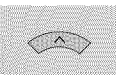
Note If you have any question or need any help for the widgets which is not covered in this manual, please contact web site for further help which shall be listed in about page of each widget, or Yahoo! help site <http://connectedtv.yahoo.com/help>.

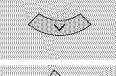
Using the Remote Control

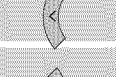
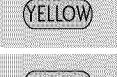
When Yahoo! TV Widgets are displayed, you can use the following remote control buttons.

Button	Operation	Button	Operation
	Begin using Yahoo! TV Widgets. Press it again to go back to just watching TV.		Select the focused item.
	Highlight and focus on buttons in the Yahoo! TV Widgets user interface.		Go to the TV Menu.
	Move the focus selection up.		Close the open widget and return to watching TV.
	Move the focus selection down.		Change the open widget's settings.
	Move the focus selection to the left.		Add, move, or delete your snippets.
	Move the focus selection to the right.		Resize the video to fit onscreen, or to make it fullscreen.

Getting Started Out of the Box

Once your television is powered up and your network is operational, the Yahoo! TV Widgets software guides you through its step-by-step on-screen wizard the first time you startup. These setup steps are designed to provide you with the information and settings you'll need to start using the Yahoo! TV Widgets user interface.

Guided Setup



Activate Yahoo! TV Widgets. The first time you use Yahoo! TV Widgets the step-by-step wizard begins with the *Welcome Screen*.

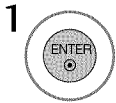

1 Select **Let's get started!**. If you select **Exit Setup now**, this step will be resumed the next time you press **WIDGETS**.

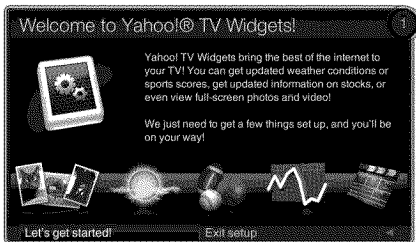

2

Choosing your country allows the use of localized content.



Navigate to your location.



Select your country.

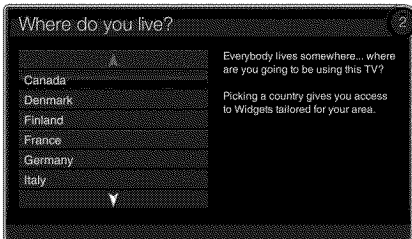

3

Accepting the Yahoo! Privacy Policy is required to use Yahoo! Widgets.



Select **Ok, I accept**.

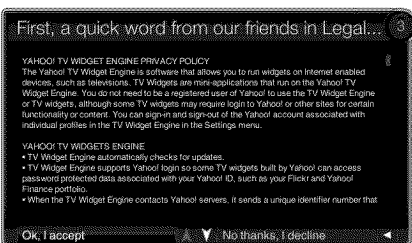

4

Accepting Yahoo! Terms of Service is also required to use Yahoo! TV Widgets.



Select **Ok, I accept**.

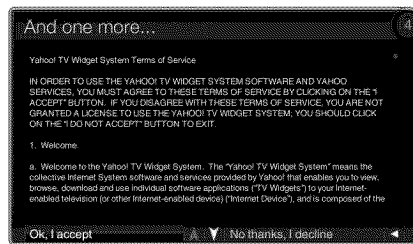

5

Enter your name to setup your profile.

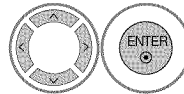

Select letters and spell your name.

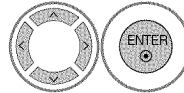

Select **Save this name** and create your profile.

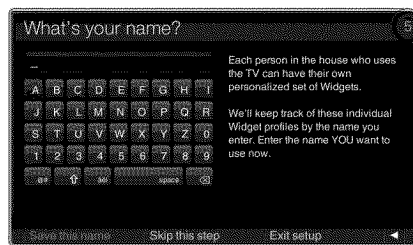

6

Test your network connection. After setup is completed, a tutorial on how to use Yahoo! TV Widgets will come up next.

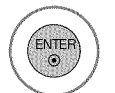

Select **Continue** and review the tutorial. Select **Exit setup** to start using Yahoo! Widgets now.

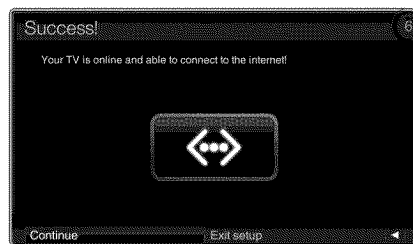

NETCAST

What is a TV Widget?

A TV Widget is an Internet application designed to run on your TV.

What is a Snippet?

A Snippet is a shortcut used to open a TV Widget, as a dynamic bookmark to TV Widget content.

Using Yahoo! TV Widgets



Activate Yahoo! TV Widgets.

- The horizontal list at the bottom of your TV screen is called “the dock”.
- The items in this list are called “snippets”.
- A snippet is a shortcut which opens a TV Widget.

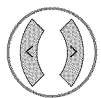

Move between snippets.

- Focus is located in the leftmost region (highlighted in dark red).
- The dock scrolls snippets under this focal point.



Open the Sidebar when the TV Widget snippet is in focus.

- The Home button including the main logo is at the top of the sidebar.

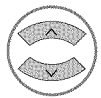

Navigate a menu item.

- The currently focused button is the one highlighted in dark red.



Select the focused button.



The sidebar's bottom toolbar includes four color-coded buttons.



Close the sidebar and return to watching TV.



Add or delete a snippet.



Change the widget's settings.



Resize video to fit onscreen, or to make it fullscreen.

Using the Profile Widget

- The **Profile Widget** configures your user profile.
- You can set up multiple profiles for multiple users.
- Each profile maintains its own list of TV Widgets.
- The **Switch Profile** menu allows you to switch to a different user profile.
- The **Profile Settings** menu allows you to customize your profile, create a profile PIN, or limit the installation of widgets.
- The **System Settings** menu allows you to change your **Location**, **Repeat the Tutorial**, and **Restore Factory Settings**.
- **Restore Factory Settings** will erase all profiles and widgets installed by users, and restore the original configuration. (See also **NetCast** → **Options** → **Reset Yahoo! Factory Settings**)
- The **Administrative Controls** menu allows you to set the **Screen Saver** timeout, create the **Owner PIN**, and to **Create a Profile**.
- The **Sign in to Yahoo!** menu allows you to personalize your experience using your Yahoo! ID.
- If you don't have a Yahoo! ID yet, please visit <http://www.yahoo.com> to create one.

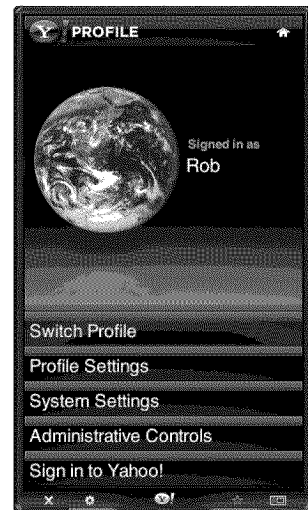

Using the Widget Gallery

- The **Widget Gallery** allows you to browse and discover new TV Widgets.
- The featured TV Widgets are highlighted in the display case at the top of the sidebar.
- You can also browse available TV Widgets by category.
- To install a widget, select **Add Widget to My Profile** and press the ENTER button.
- The **Owner PIN** is needed to install widgets for profiles that have been protected through the **Limit Profile** indicator under **Profile Widget** → **Profile Settings**.
- Go to the **Profile Widget** → **Administrative Controls** menu to set or change the **Owner PIN**.



Using the Yahoo! News Widget

- The **Yahoo! News Widget** provides the latest headline news for business, entertainment, politics, sports, top stories, and many other categories.
- Select a category, press **ENTER**.
- Select a headline within the category, press **ENTER**.
- View the dynamically updated news summary for the selected headline.



Using the Yahoo! Weather Widget

- The **Yahoo! Weather Widget** provides updates on your local and favorite weather locations with content that dynamically changes with weather conditions.
- Press the **GREEN** button to display the **Settings** menu.
- From the **Settings** menu you can add or remove a city for which you want to view weather information.
 - **Add a New City** by entering the name of the city. Once the search results are displayed, select the city you want and press **ENTER** button.
 - **Delete a City** by selecting the city you want to delete from the city list. Press **ENTER** button and confirm the deletion.
 - Select the **Display Units As** button to change the temperature indication mode to **Imperial** or **Metric**. **Imperial** will show temperatures in Fahrenheit and **Metric** will use Celsius.
- To create a snippet for a favorite city:
 - Select the city from the home page and view the detailed weather information.
 - Press the **YELLOW** button.
 - Select the **Add Snippet** button and press **ENTER** to add the city as a snippet.
- To delete a snippet for a city:
 - Navigate to the snippet and press **ENTER** button to start the widget. The detailed page for the snippet's city will be displayed.
 - Press the **YELLOW** button.
 - Select the **Delete Snippet** button and press **ENTER** button to remove the snippet.



Using the Yahoo! Finance Widget

- View stock information and the latest stock news with the Yahoo! Finance Widget.
- Press the **GREEN** button to set up your stocks.
 - Use the **Add New Symbol** menu to enter the name of a new stock.
 - Select the stock you want to add from the search results and select the **Add Symbol** button and press **ENTER** button.
 - The selected stock is added to the **My Stocks** list.
 - The **Import Symbols From Yahoo!** menu retrieves the stocks from your Yahoo! Finance portfolio.
 - The **Merge Symbols** button merges the symbols in the Yahoo! Finance Widget with the symbols from your portfolio.
 - The **Replace Symbols** button deletes the symbols in the Yahoo! Finance Widget and replaces them with the symbols from your portfolio.
 - The **Display Format** button changes the stock-price fluctuation transition to **Value** or **Percentage**.
- To create a snippet for a favorite stock:
 - Select the stock symbol from the home page and view the detailed finance information.
 - Press the **YELLOW** button.
 - Select the **Add Snippet** button and press **ENTER** button to add the stock as a snippet.
- To delete a snippet:
 - Navigate to the snippet and press **ENTER** button to start widget. The detailed page for the snippet's stock will be displayed.
 - Press the **YELLOW** button.
 - Select the **Delete Snippet** button and press **ENTER** button to remove the snippet.

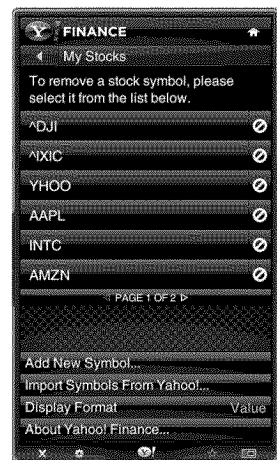

Using the flickr Widget

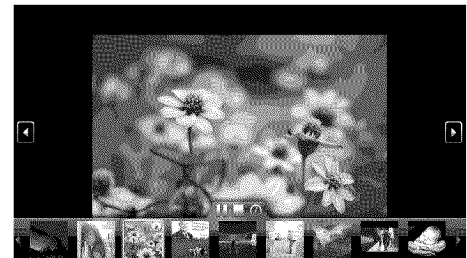

- The **flickr Widget** provides a television-viewing experience while watching slideshows of family and friends' photos.
- Personalize the **flickr Widget** by logging in with your Yahoo! ID. Refer to **Using the Profile Widget** for instructions.
- The **Your Photos** menu shows photos you have registered with the flickr website.
- The **Your Sets** menu allows you to view photos you have classified in flickr.
- The **Explore** menu allows you to explore photos featured by the flickr website.
- The **Mark as Favorite** moves photos to your **Favorite Photos** set.
- The **Favorite Photos** menu allows you to see the photos you have classified as favorites.
- The **Your Contacts** menu allows you to see updates from family and friends.
- The **Your Groups** menu allows you to select your favorite groups from the flickr website <http://www.flickr.com> to share and enjoy photos with the flickr community of users.
- To view photos in a slideshow:
 - Select a thumbnail of a photo and press **ENTER** button to view the photo's details.
 - Select **Start Slideshow** and press **ENTER** button.
- To control the slideshow display:
 - Press **ENTER** button during a slideshow.
 - The thumbnails of photos are displayed on the bottom of the screen.
 - When the slideshow control is displayed, you can **Pause**, **Play**, and **Stop** the slideshow.
 - If you select the **INFO** button and press **ENTER** button, you can view details for the selected photo.
- To configure the **Settings**, press the **GREEN** button.
 - The **Time Per Slide** button controls the speed of the slideshow.
 - The **Repeat** button will restart the slideshow at the beginning after the last photo is shown.

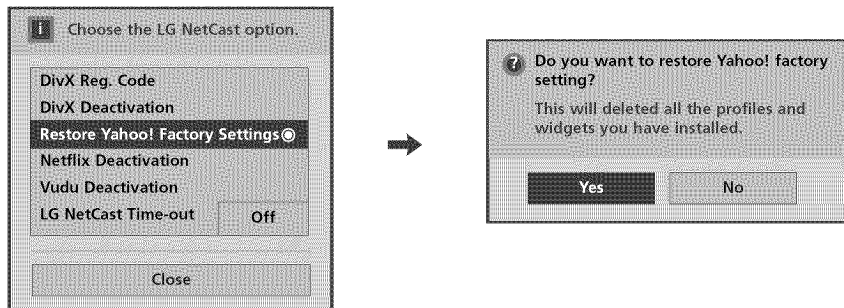

Restore Yahoo! Factory Settings

Restoring Yahoo! Factory Settings will delete all of your profiles and installed widgets.

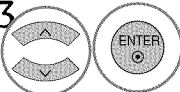
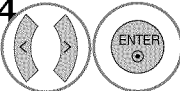

-  1 Display **NetCast** menu.
-  2 Select **NetCast** option.
-  3 Select **Restore Yahoo! Factory Settings**.
-  4 Select **Yes** to restore Yahoo! factory settings.
This TV will restore Yahoo! factory settings.

NETFLIX

Your TV's OSD (On Screen Display) may differ slightly from that shown in this manual.

Activating the TV

You can instantly watch movies (quite a few new releases) & TV episodes from Netflix streamed over the internet to your TV.

To become a Netflix member visit: www.netflix.com/LG

Activating your TV establishes a connection between your TV and your Netflix account. You must activate your TV before you can use it to watch movies streamed over the INTERNET from Netflix.

If newer software is needed, a software update screen will automatically appear (Refer to P.68).

Note that this service is provided by the Content Provider, Netflix. It is dependent on Netflix to provide the data.

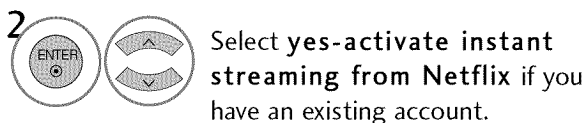

- **no-start my FREE trial:** If you have no account, visit <http://www.netflix.com/LG> on your computer.



- 3 Visit the Netflix website on your computer:

www.netflix.com/activate

Enter your Sign in Name and Password to log into your account.



4

See the activation code on your TV screen,



Activation Code

Enter this activation code to the Netflix Website and click **Activate**.

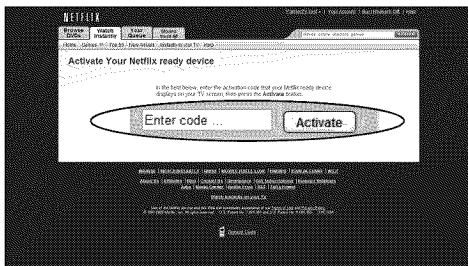

5

Wait for the poster screen to appear on your TV.



6

You're ready to add movies to your instant Queue. See **Filling your instant Queue** for instruction (Refer to P.80).

Need help with Netflix?

Not a Netflix Member?

Learn more about Netflix, including how to get a free trial:

www.netflix.com/LG

Already a Netflix Member?

Get help with your Netflix membership:

www.netflix.com/tvhelp

Or call us at: 1-866-716-0414 (USA only)

Filling your instant Queue

After you activate your TV, you're ready to add movies & TV episodes to your instant Queue. You can use your TV's remote to browse your instant Queue and to select and watch titles on your TV.

Your instant Queue works just like your DVD Queue. Add and manage the movies & TV episodes in your instant Queue from the Netflix website on your computer. Your instant Queue also appears on your TV, so your selections are available to watch anytime.

1

Visit the Netflix website on your computer:
<http://www.netflix.com>

Enter your Sign in Name and Password to log into your account.

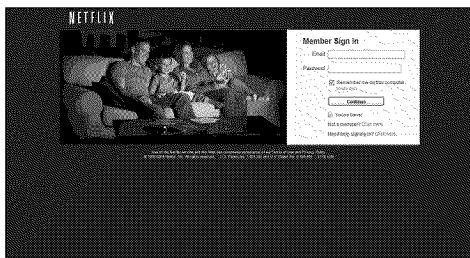

2

Click **Watch Instantly**.

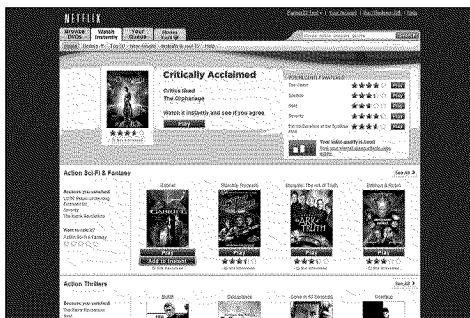

3

Search a movie or TV episode you want to watch and mouse over the **Play** button to reveal additional options, and then click **Add to Instant**.

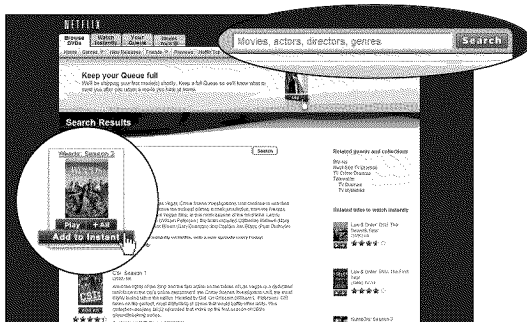

4

Repeat step 3 to add more movies & TV episodes to your instant Queue.

5

Click **Your Queue** to see your instant Queue list. Arrange your instant Queue by clicking the **Instant** subtab.

- To rearrange your instant Queue, drag and drop the titles in the order you want them, or change the numbers to the left of the titles and then click **Update Instant Queue** to your changes.
- To remove a title from your instant Queue, click the **Remove** check box to the right of the title and then click **Update Instant Queue** to your changes.

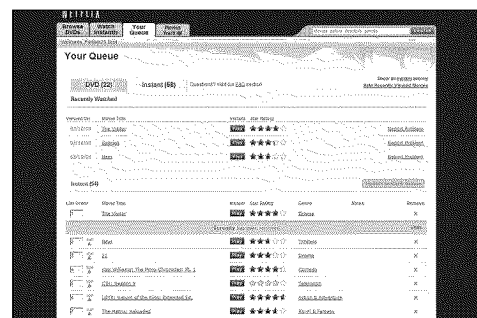
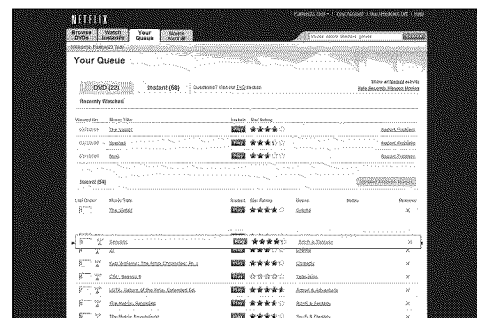

Netflix Deactivation

Once deactivated, TV will no longer instantly stream from your Netflix Instant Queue.

If you deactivate, the TV cannot instantly stream from your Netflix Instant Queue.

If you want, you can activate Netflix later (Refer to P.78-79).

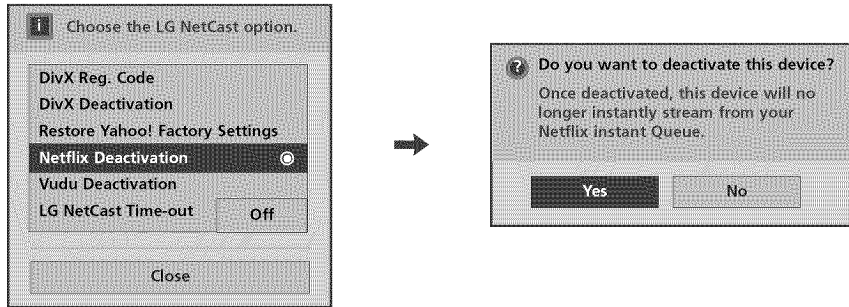

- 1 Display NetCast menu.
- 2 Select NetCast option.

- 3 Select Netflix Deactivation.
- 4 Select Yes to deactivate the TV. This TV is not currently activated to instantly stream from your Netflix instant Queue.

The Poster Screen Components

It shows “box art” (title-specific DVD cover or movie poster images) for each of the movies in the member’s instant Queue, and allows navigation through that Queue using the remote control. The instant Queue is a list of movies and television shows selected previously by the member on the Netflix web site.

- 1 Position of selected title
- 2 Total number of titles
- 3 Non-selected title box art
- 4 Selected title box art
- 5 Selected title name
- 6 Selected title runtime (if episodic title, count of episodes available to watch instantly for that title, e.g. “12 episodes”)
- 7 Selected title parental rating
- 8 HD icon (Displays only when a title is available in HD 720p resolution.)

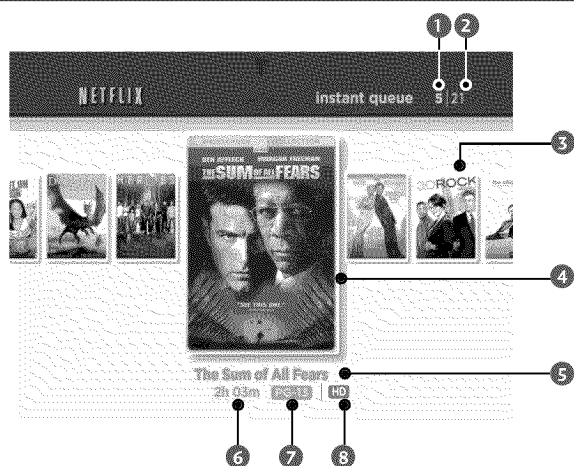

The Springboard Screen Components

It shows a synopsis and other details about the title, and lists actions that can be taken on it.

There are two versions—one for non-episodic titles (single movies), and one for episodic titles (TV series with multiple episodes, or a movie compilation with several movies).

- 1 Position of this title
- 2 Total number of titles
- 3 Title name or Series/Season
- 4 Resume Playing (It appears if the title has already been partially watched. If the title has not already been watched, this will say Play)
- 5 Play From Beginning (If the title has not already been watched, it will not show this, and move remaining choices up on layout)
- 6 Ratings
- 7 Remove from instant Queue
- 8 Play current episode (shows episode number of currently-selected episode)
- 9 Choose a different episode (Navigates to Episodic Selection Screen)
- 10 Director
- 11 Genres
- 12 Box art
- 13 Cast members
- 14 Episode title
- 15 Synopsis
- 16 Year of release
- 17 Runtime
- 18 Title parental rating
- 19 HD icon (If a title is available in HD 720p resolution)

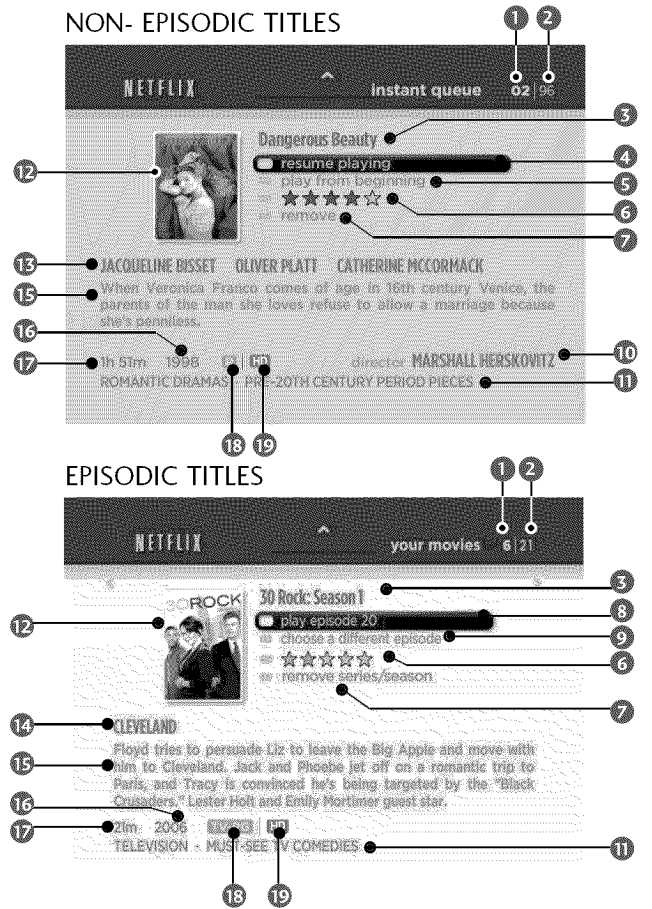

The Episodic Selection Screen Components

It is accessed by selecting **choose a different episode** on the **Episodic Springboard Screen**, and shows a list of episodes, centered on the currently-bookmarked episode. It allows selection of other episodes of a series, and also shows which episodes have been previously watched.

- 1 Series: Season name
- 2 Non-selected episode
 - Dark type episode number: When a episode is available to watch instantly and it has not been watched.
 - Lighter type episode number: When a episode has been watched.
 - Disc only: When a episode is not available to watch instantly and it is available on disc.
 - No reference: When a episode is neither available to watch instantly nor is on DVD
- 3 Currently-selected episode (shows same information as non-selected episodes, plus, if the episode has been watched, a progress bar showing % of runtime watched)

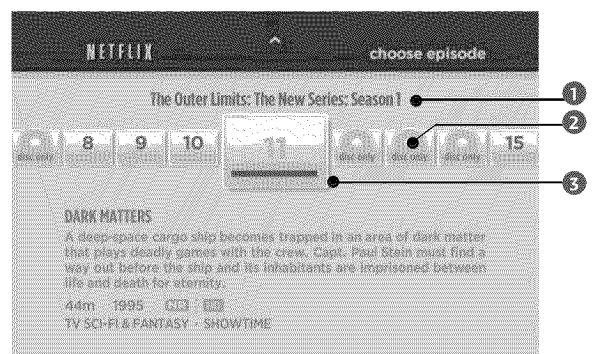







Selecting a movie or TV episode to watch on your TV



After you set up your TV and add movies & TV episodes, you can watch them on your TV.



While watching a movie or TV episode from Netflix via your TV, you have full control over your viewing experience.







1    Select **Watch Instantly**.
The poster screen will appear.

2   Select the desired title on your instant Queue.
(At this time, you can play the selected title directly using  button.)

  Move to the previous or next page.

3  or  Display the springboard screen.
You can view details for the selected title and play the selected title directly using  button.)

4    Choose any of the menu items

5  or  Return to the poster screen.

6  Exit **Netflix** and display the **NetCast** menu.



 Exit **Netflix** and display the **TV** menu.

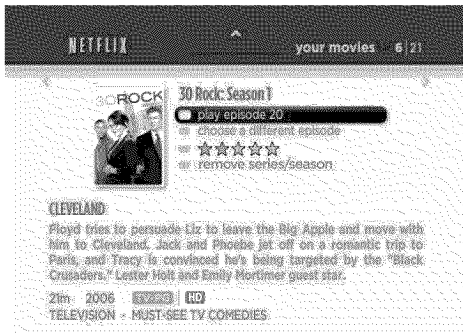

- **play**: Starts playing the selected title.
- **resume playing**: Plays a previously paused title from the scene where you paused it. This option is available only if you begin watching a title and then pause it.
- **play from beginning**: Starts playing from the beginning of the selected title.
- **choose a different episode** (TV series only): Enables you to select a specific show of a TV series (P.84).
- **rate**: Enables you to rate a movie or TV series. The more stars, the higher the rating (P.85).
- **remove**: Deletes the selected movie from your instant Queue.
- **remove series** (TV series only): Deletes the selected TV series from your instant Queue.

- It's possible to use **Q.MENU** (Aspect Ratio 16:9 or Set By Program, Picture Mode, Sound Mode, Sleep Timer, and USB Device) when using Netflix.

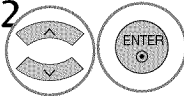
A Different Episode Selection

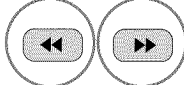



- 1 Repeat step 1-3 on P. 83.
- 2  Select **choose a different episode**.
- 3  Select the desired episode.
-  Move to the previous or next page.

- 4  Play the episode.
-  Return to the springboard screen.
-  Return to the poster screen.

Movie Rating / Parental control

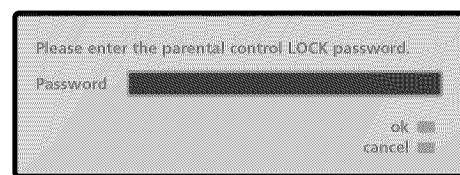
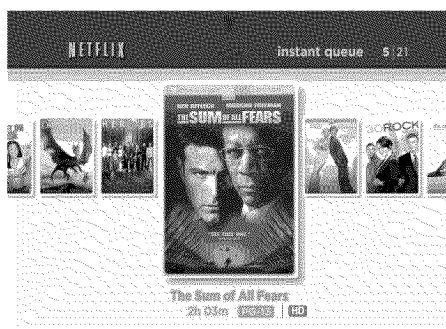
Lock menu settings for TV programs (Refer to P.161 -167) are also applied to the Netflix interface. The Password window will be displayed if you try to watch a movie or TV episode with a level higher than that set from the Lock menu.



- 1 Repeat step 1-3 on P. 83.
- 2  Play the episode.
- 3  Input the password.
- 4  Select **ok**.

Rating Selection

It shows the predicted rating for a title for that member (red stars), or the actual rating that member gave the title (yellow stars).

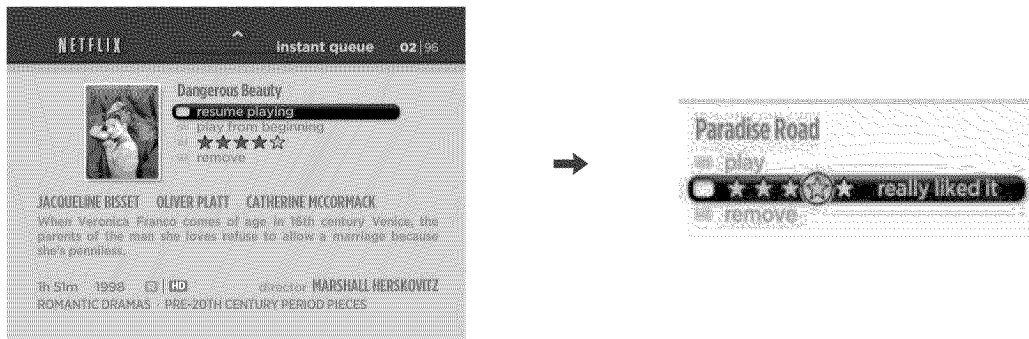

1

Repeat step 1-3 on P. 83.

2



Select Rating.

3

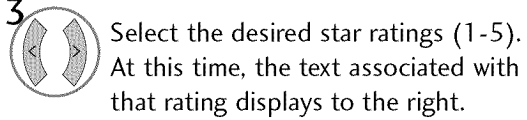

Select the desired star ratings (1-5).
At this time, the text associated with that rating displays to the right.

4

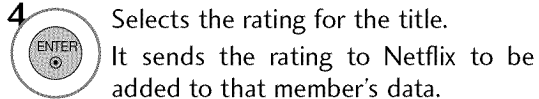

Selects the rating for the title.
It sends the rating to Netflix to be added to that member's data.

Pre-Playback

It appears when you have first pressed play for a title, and shows information about the title while it is being retrieved and buffered from Netflix.

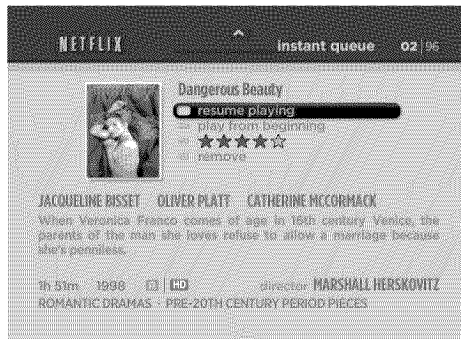

- 1 Title name or Series (Season name)
- 2 Episode name (Episodic titles only)
- 3 Retrieving bar
- 4 Quality of stream being buffered. Amount that "meter" is filled in depends on bitrate of stream being buffered.
- 5 HD icon (Displays only if an HD stream is being loaded. If an HD stream is available but the user cannot receive it due to low bandwidth, it will not show the HD icon).

1

Repeat step 1-3 on P. 83.

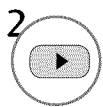

Play the title or episode.

On Pre-Playback Screen

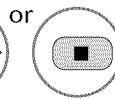
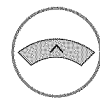

or Stop the playback and return to the springboard screen.

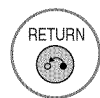

Stop the playback and return to the poster screen.



NOTE

- ▶ Audio/video quality may be compromised based on the speed of your broadband internet connection. Netflix will adjust the speed automatically based on the available bandwidth.
- ▶ Your Internet Service Provider (ISP) determines your broadband speed. We recommend a minimum connection speed of 800 Kbps. For the best quality picture, a connection speed of 4.0 Mbps is required.
- ▶ Sometimes your broadband speed varies based on your ISP's network conditions. Contact your ISP if you have problems maintaining a fast connection that is reliable, or if you want to increase your connection speed. Many ISPs offer a variety of broadband speed options.
- ▶ On the Netflix screen, the TV will return to previous input source when there is no user input for 30 minutes except when streaming video.
- ▶ *For Plasma TV: If there is no user input within 2 minutes when streaming video, the screen saver appears to prevent a fixed image remaining on screen.*

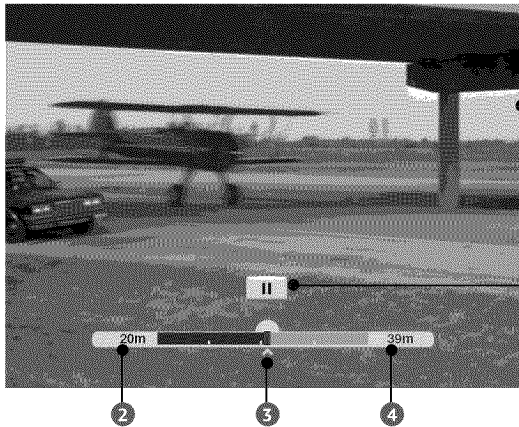

Pause Playback (Still Mode)



- 1 Pause indicator
- 2 Runtime of current position in title
- 3 Progress bar showing current position in title
- 4 Runtime remaining

- 1  Pause the title or episode during playback.
- 2  Restart the normal playback.

On Pause Playback Screen



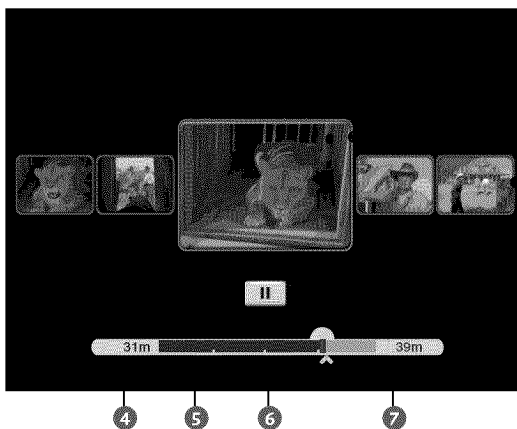
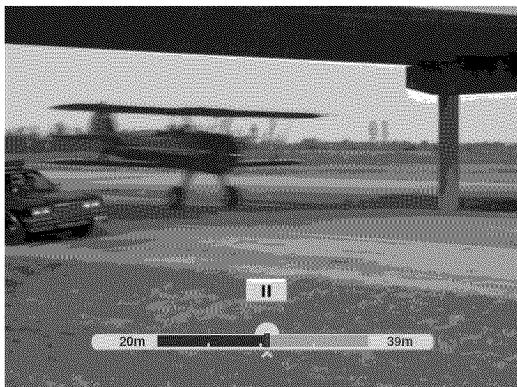

-  or  Stop the playback and return to the springboard screen.

Trick Playback



It allows you to scan or step forward or back through a title to pick a specific scene or time. It presents a series of thumbnail frames taken approximately every 10 seconds.



- ① Currently-selected frame
- ② Next and previous frames (approximately -20, -10, +10, +20 seconds offset from center frame).
- ③ Trick play mode indicator (Paused, skip forward/back mode)
- ④ Timecode in title for currently-selected frame
- ⑤ Spot in title where you entered trick play
- ⑥ Position indicator in progress bar for currently-selected frame
- ⑦ Runtime remaining in title at currently-selected frame

- 1  Enter the trick play mode in still picture.
- 2  Select desired frame.
-  Exit trick play mode and restart playback at original spot in title (where you entered trick play).
- 3  or  Start playback of the selected frame.

On Trick Playback Screen

-  Stop the trick play mode and return to the springboard screen.
-  Stop the playback and return to the poster screen.

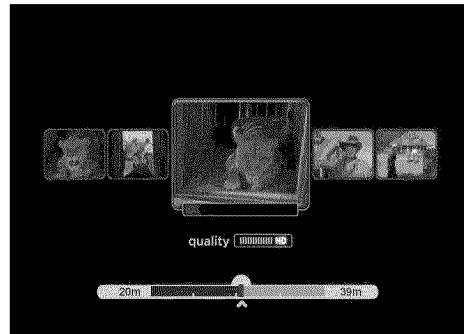
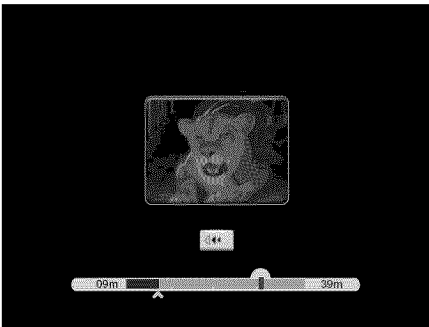
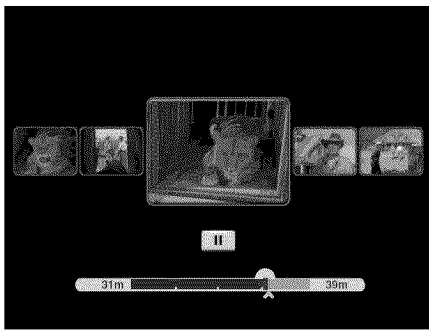

In fast skip mode (2x or 3x forward or backward), it shows only current frame thumbnail on the center.

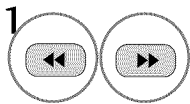

Enter the trick play skip mode, select the desired speed of scanning through the movie: cycle through 1, 2, 3x speed for skipping through frames.

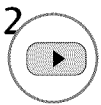

Start playback of the selected frame. At this time, you will check the current bandwidth available, determine the optimal bitrate for network conditions, and then buffer the appropriate stream.

MY MEDIA

In USB device, you can not add a new folder or delete the existing folder.

1 Connect the USB device to a **USB IN** jack on the TV.

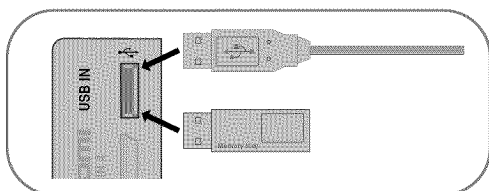

2   Select **MY MEDIA**.

3    Select **PHOTO LIST, MUSIC LIST, or MOVIE LIST**.

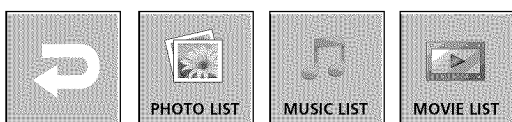

■ This TV can view JPG image files and play MP3 audio files.

When removing the USB device

Eject the **USB Device** menu before removing the USB device.

1   Select **USB Device**.

2  Select **Eject**.

Precautions when using the USB device

- ▶ Only a USB storage device is recognizable.
- ▶ connecting a USB storage device through a USB hub is not supported
- ▶ A USB storage device which uses its own driver may not be recognized.
- ▶ The recognition speed of a USB storage device may depend on each device.
- ▶ Please do not turn off the TV or unplug the USB device when the connected USB storage device is working. When such device is suddenly separated or unplugged, the stored files or the USB storage device may be damaged.
- ▶ Only use a USB storage device which has normal music files or image files.
- ▶ Please use only a USB storage device which was formatted as a FAT 32 or NTFS file system provided with the Windows operating system. Others may not be recognized.
- ▶ Some USB storage devices require a power adapter. The power adapter must be connected in order to be seen by the TV.
- ▶ If a device is not recognized by the TV, try a different cable. Excessively long cables are not supported.
- ▶ Some USB storage devices may not be supported or operate properly.
- ▶ Please backup important files because data on USB device could be damaged. Data management is consumer's responsibility and as a result, the manufacturer does not cover data damage.
- ▶ If your USB memory device has multiple partitions, or if you use a USB multi-card reader, you can use up to 4 partitions or USB memory devices.
- ▶ In case of USB storage devices formatted as NTFS, deletion is not supported.
- ▶ File alignment method of USB storage device is similar to Window XP and file names can be up to 100 English characters.
- ▶ The recommended capacity is 1TB or less for a USB external hard disk and 32 GB or less for USB memory.
- ▶ If a USB external hard disk with a "Energy Saving" function doesn't work, turn the hard disk off and on again to make it work properly. Refer to the user manual of the USB external hard disk.

Share folder (CIFS: Common Internet File System) Setup

■ The method of setting the shared folder may be different by the OS environment.

Case 1

- 1 Click **Sharing** on the CIFS folder under the C Drive.

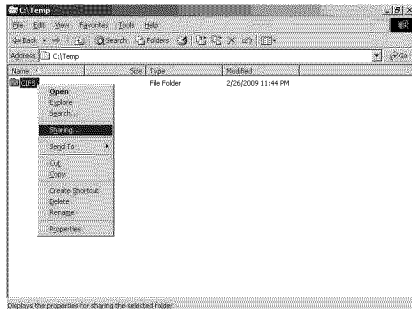

- 2 Check **Share this folder** and click **Apply**.

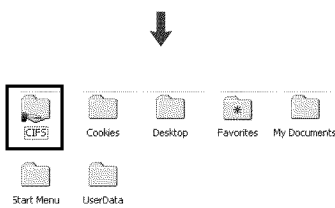
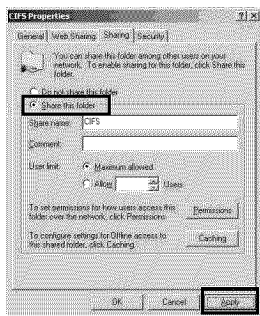

Case 2 (For Window Vista)

- 1 Choose the folder that you want to share. Then, right-click and click **Share**.

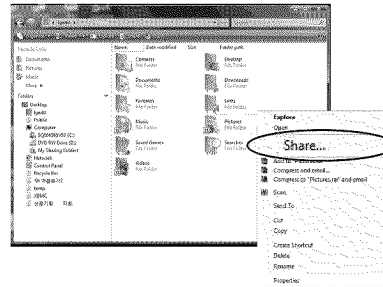

Add the **Everyone** and click **Share**.

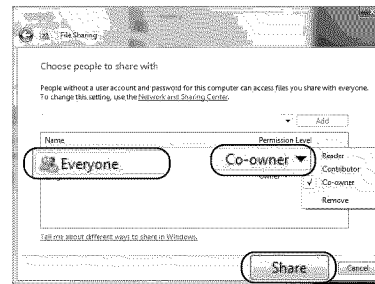

- 2 Choose the folder that you want to share. Right-click and click **Properties**. Click **Advanced Sharing** on **Sharing** tab. Check **Share this folder** and click **Permissions**. Add **Everyone** and check **Full Control - Allow**.

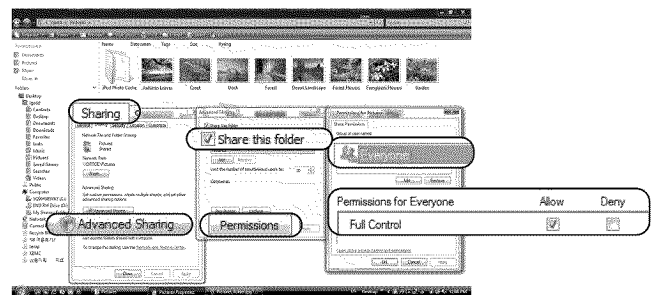

- 3 Check **File sharing-On**, **Public folder sharing-On**, and **Password protected sharing-Off**.

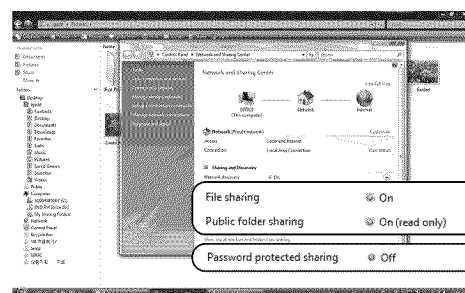

Viewing Files on the Network

You can view the photos or listen to music files from folders shared on the network.

- 1 Set a share folder (CIFS: Common Internet File System) on the PC (Refer to P.91).
- 2 Connect the LAN port of the Modem or Router to the LAN port on the TV.

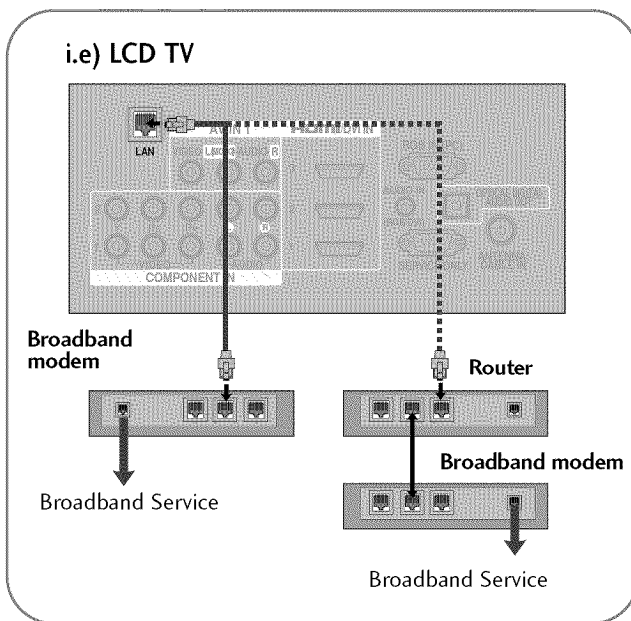

- 3 Select MY MEDIA.

- 4 Select PHOTO LIST, MUSIC LIST, or MOVIE LIST.

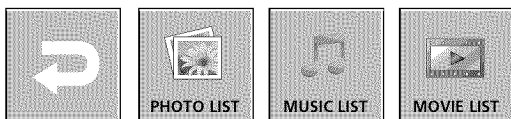

- Connect the PC and TV using a sharing device so that you can see the PC's shared files on the TV.
- How to set a share folder may differ depending on the Windows version.
- The speed may be slow or it may cause an error if you try to access a folder from two TVs at the same time.
- Because files could be deleted from a shared PC, set the user access level to Read Only.
- Do not share any important personal documents as it may be accessed by a different PC.
- If you rename or disable a shared folder on the PC after mounting, you cannot mount it again.
- If the status of the network or a share folder on the PC is changed, search is run again when entering the highest folder in the menu.
- A maximum of 20 of shared folders on 4 computers are supported.
- When using file sharing from a computer, it is recommended you use a wired port of the hub.
- When using the wireless port of the hub to share the file on the PC, some functions can be limited.
- Because the TV does not support the wireless function using the USB dongle, My Media function only supports the wired environment.

PHOTO LIST

You can view .JPG files from USB storage devices or the folder shared on the network.
The On-Screen Display on your model may be slightly different.

Supported photo file: *.JPG

- You can play JPG files only.
- Available JPG size
Baseline: 64 pixel (width) x 64 pixel (height) to 15360 pixel (width) x 8640 pixel (height)
Progressive: 64 pixel (width) x 64 pixel (height) to 1920 pixel (width) x 1440 pixel (height)

Screen Components

- ① Moves to upper level folder
- ② Preview: Display the thumbnail/folder name of the photo in the selected folder
- ③ Current page/Total pages
- ④ Total number of marked photos
- ⑤ Corresponding buttons on the remote control

The screenshot shows a 'Photo List' screen. On the left, a preview window displays a butterfly image with the text 'Drive1 butterfly' and '1366x768, 125KB'. Below it is an 'Up Folder' button. On the right, a table lists photos with checkboxes for marking. At the top right, it says 'Page 2/3' and 'No Marked'. At the bottom, a navigation bar contains buttons for 'Navigation', 'Popup Menu', 'CH', 'Page Change', 'MARK Mark', and 'Exit'.

Up Folder		<input checked="" type="checkbox"/> butterfly	04/05/2008	
<input checked="" type="checkbox"/>	G_990425_show	04/05/2008	<input checked="" type="checkbox"/> G_040704_arena	04/05/2008
<input checked="" type="checkbox"/>	G_051224_dome	04/05/2008	<input checked="" type="checkbox"/> G_060114_korea	04/05/2008
<input type="checkbox"/>	G_070107_drama	04/05/2008		

Photo Selection and Popup Menu

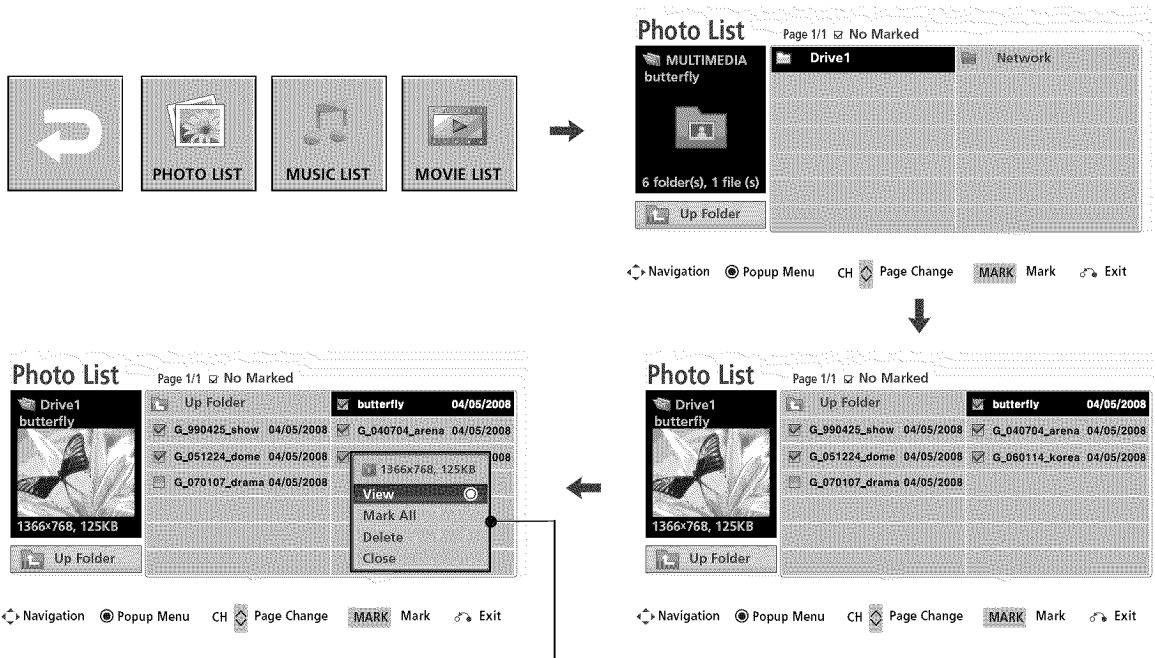

When you select a file (not folder), this PopUp menu is displayed.

- ▶ **View:** Display the selected item.
When you select "Network", you can only see photo files within a shared folder of a PC.
When you select "Drive" you can only see photo files from a USB drive.
- ▶ **Mark All:** Mark all photos on the screen.
- ▶ **Unmark All:** Deselect all marked photos.
- ▶ **Delete (USB file only):** Delete the selected photo item.
Files in a shared folder of a PC cannot be deleted.
- ▶ **Close:** Close the pop-up menu.

- 1 Select MY MEDIA.
- 2 Select Photo List.
- 3 Select the target drive or Network.
- 4 Select the desired photos.

- 5 Show the Popup menu.
- 6 Select the desired option in the Popup menu.

- Use the CH ^ v button to navigation in the photo page.
- Use the MARK button to mark or unmark a photo. When one or more photos are marked, you can view individual photos or a slide show of the marked photos. If no photos are marked, you can view all photos individually or all photos in the folder in a slide show.

Full Screen Menu

You can change the Photo List view so that it fills the screen. More operations are available in full screen mode.

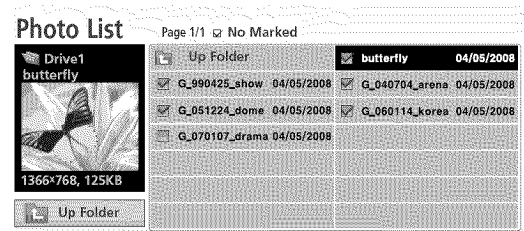



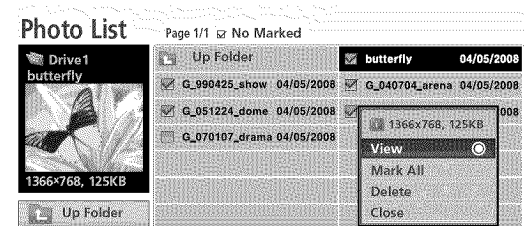

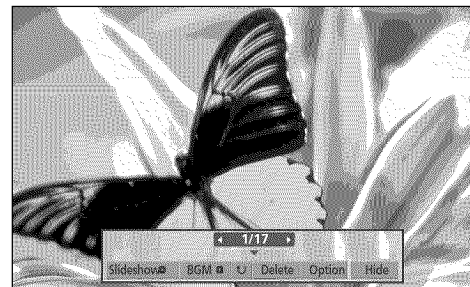

Navigation Popup Menu CH Page Change MARK Mark Exit



Navigation Popup Menu CH Page Change MARK Mark Exit



The aspect ratio of a photo may change the size of the photo displayed on the screen in full size.

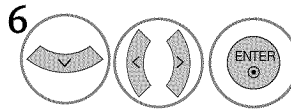
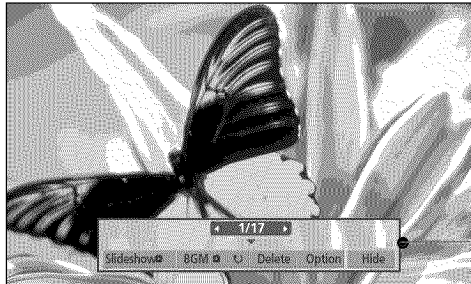

- 1  Select the target drive or Network.
- 2   Select the desired photos.
- 3  Show the Popup menu.
- 4  Select View.
- 5  The selected photo is displayed in full size.

Use the CH   button to navigation in the photo page.



6 Select the **Slideshow**, **BGM**,  (**Rotate**), **Delete**, **Option**, or **Hide**.

- Use < > button to select the previous or next photo.
- Use ^ v < > button to select and control the menu on the full-sized screen.

- ▶ **Slideshow:** Selected photos are displayed during the slide show. If no photo is selected, all photos in the current folder are displayed during slide show.
 - Set the time interval of the slide show in **Option**.
- ▶ **BGM:** Listen to music while viewing photos in full size.
 - Set the BGM device and album in **Option**.
- ▶  (**Rotate**): Rotate photos.
 - Rotates the photo 90°, 180°, 270°, 360° clockwise.
 - Photo cannot be rotated if its width is greater than the available supported resolution height.
- ▶ **Delete** (USB file only): Delete photos.
- ▶ **Option:** Set values for **Slide Speed** and **Music Album**.
 - Use ^ v < > button and **ENTER** button to set values. Then go to  and press **ENTER** to save the settings.
 - You cannot change **Music Album** while BGM is playing.
- ▶ **Hide** : Hide the menu on the full-sized screen.
 - To see the menu again on the full-sized screen, press **ENTER** button to display.

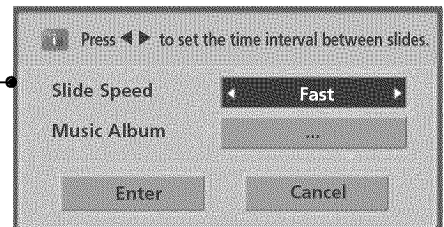

NOTE

- ▶ This TV will not be able to decode most JPG images saved using the Progressive option.

MUSIC LIST

You can use the Music List menu to play MP3 files from a USB storage device or the folder shared by the network.

This TV cannot play back copy-protected files.

The On-Screen Display on your model may be slightly different.

Supported music file: *.MP3

- Bit rate range 32 Kbps - 320 Kbps
- Sampling rate (Sampling Frequency)
 - MPEG1 layer 3: 32 kHz, 44.1 kHz, 48 kHz
 - MPEG2 layer 3: 16 kHz, 22.05 kHz, 24 kHz
 - MPEG2.5 layer 3: 8 kHz, 11.025 kHz, 12 kHz

Screen Components

- ① Moves to upper level folder.
- ② Preview: If any album jacket for the file exists, it is displayed.
- ③ Current page/Total pages.
- ④ Total number of marked files.
- ⑤ Corresponding buttons on the remote control.

Music Selection and Popup Menu

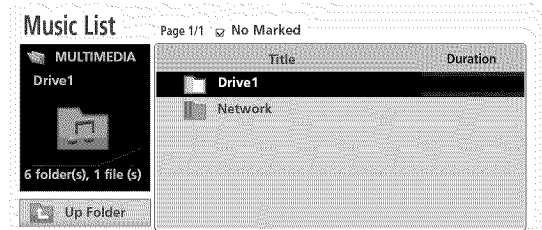
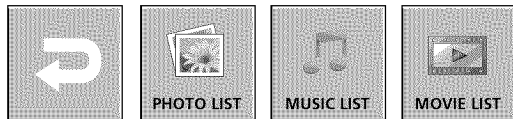

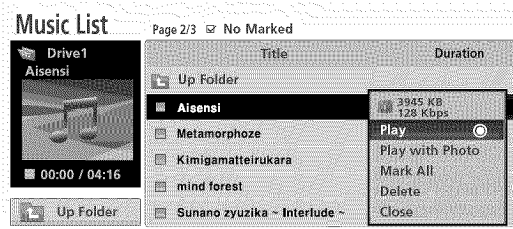

Navigation Popup Menu CH Page Change MARK Mark Exit



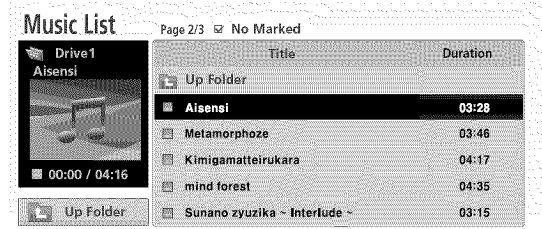



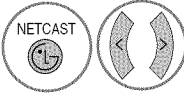
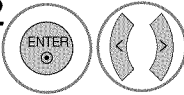
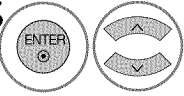
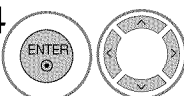

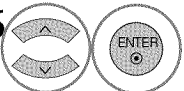

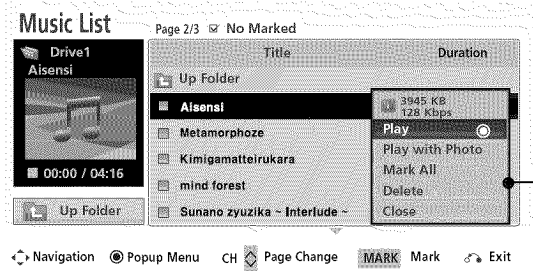
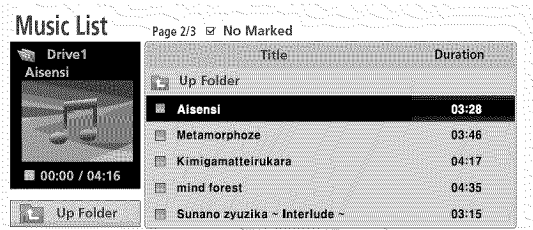
Navigation Popup Menu CH Page Change MARK Mark Exit



Navigation Popup Menu CH Page Change MARK Mark Exit

- 1  Select MY MEDIA.
- 2  Select Music List.
- 3  Select the target drive or Network.
- 4  Select the desired music files.
- 5  Show the Popup menu.
- 6  Select the desired option in the Popup menu.



- 1  Select the target folder or drive.
- 2   Select the desired music files.
- 3  Show the Popup menu.
- 4   Select the desired option in the Popup menu.
- 5  Return to TV viewing.

▶ **Play (During stop):** Play the selected song. Once a song finishes playing, the next selected one will be played. When there are no selected songs to play, the next one in the current folder will be played. If you go to a different folder and press the **ENTER** button, the current songs in playback will stop.

When you select “Network”, you can only listen to the music files in a shared folder on a PC. When you select “Drive” you can only listen to the music files from a USB drive.

▶ **Play Marked:** Play the selected songs. Once a song finishes playing, the next selected one will be played automatically.

▶ **Stop Play (During playback):** Stop the playing the song.

▶ **Play with Photo:** Start playing the selected songs and then move to the Photo List.



▶ **Mark All:** Mark all songs in the folder.

▶ **Unmark All:** Deselect all marked song.

▶ **Delete (USB file only):** Delete the selected song.

Files in a shared folder of a PC cannot be deleted.

▶ **Close:** Close the pop-up menu.

■ Use the **CH**   button to navigation in the music page.



■ Use **MARK** button to mark or unmark a music file. If no music is marked, all the music in the folder will be played in sequence. When one or more music files are marked, the marked music files will be played in sequence. If you want to listen to only one song repeatedly, just mark that one file and play.

NETCAST

- The play information box (as shown below) will automatically move across the screen when there is no user input to prevent a fixed image remaining on the screen for an extended period of time.



NOTE

- ▶ When music is playing,  is displayed in front of the music play time.
- ▶ A damaged or corrupted music file that does not play displays 00:00 as the play time.
- ▶ Music files with copy-protection will not play.
- ▶ Press ENTER, , or RETURN button to stop the screen saver.

MOVIE LIST

The movie list is activated once a USB drive is detected. It is used when playing movie files on the TV. It displays all of the video files it recognizes.

The On-Screen Display on your model may be slightly different.

- Max bitrate of playable movie file: 20Mbps (Mega bit per second)
- Bit rate of audio format: within 32 ~ 320kbps (MP3)
- Supported subtitle format : *.smi, *.srt, *.sub (MicroDVD, SubViewer1.0/2.0), *.ass, *.ssa, *.txt (TMPlayer), *.psb (PowerDivx)

Screen Components

- ① Moves to upper level folder
- ② Current page/Total pages
- ③ Total number of marked movie
- ④ Corresponding buttons on the remote control

Non-supported files are displayed using this graphic.

Navigation Popup Menu CH Page Change MARK Mark Exit

Precautions when playing the video files

- ▶ Some user-created subtitles may not work properly.
- ▶ Some special characters are not supported in subtitles.
- ▶ HTML tags are not supported in subtitles.
- ▶ Subtitles in languages other than the supported languages are not available.
- ▶ Time information in an external subtitle file should be arranged in ascending order to be played.
- ▶ The screen may suffer temporary interruptions (image stoppage, faster playback, etc.) when the audio language is changed.
- ▶ A damaged video file may not be played correctly, or some player functions may not be usable.
- ▶ Video files produced with some encoders may not be played correctly.
- ▶ If the video and audio structure of recorded file is not interleaved, either video or audio is outputted.
- ▶ Video with resolution higher than maximum resolution supported for each frame, cannot be guaranteed for smooth playback.
- ▶ Movie files other than the specified types and formats may not work properly.
- ▶ Files encoded with GMC (Global Motion Compensation) or quarter pel motion estimation may not be played.
- ▶ Only the files saved in ASCII Code is supported in subtitles.
- ▶ Only 250 Korean characters, 500 alphabets and 500 numbers are supported for each line of the subtitle.
- ▶ Only 10,000 of sync blocks can be supported within the subtitle file.
- ▶ H.264 codec is supported up to profile level 4.1.
- ▶ DTS Audio codec is not supported.
- ▶ A video file more than 30GB in file size is not supported for playback.
- ▶ Playing a video via a USB connection that doesn't support high speed may not work properly.
- ▶ USB storage devices below USB 2.0 are supported as well. But they may not work properly in the movie list.
- ▶ The video file and its subtitle file must be located in the same folder.
- ▶ At this time, a video file name and its subtitle file name must be identical for it to be displayed.
- ▶ When you are watching the movie by Movie List function, you can adjust the picture by ENERGY SAVING and AV MODE button on the remote control. User setup for each picture mode does not operate.
- ▶ Even the supported codec may not be played depending on the encoded condition.
- ▶ Files had with not index may not be operated normally.

NETCAST

Supported DivX file

File Extensions	A/V	Codec	Profile/Level Support	Explanation
.asf .wmv .wma	Video	VC-1 Advanced Profile	Advanced Profile@Level 3 (eg. 720p60, 1080i60, 1080p30)	Only streams compliant to SMPTE 421 M VC-1 standard are supported.
		VC-1 Simple and Main Profiles	Simple Profile@Medium Level (eg. CIF, QVGA) Main Profile@High Level (eg. 1080p30)	
	Audio	WMA Standard		
		WMA 9 Professional		
.divx .avi	Video	DivX3.11	Advanced Simple Profile (eg. 720p/1080i)	Global motion compensation or quarterpel motion estimation does not supported. Streams using this syntax are not supported.
		DivX4		
		DivX5 DivX6		
	XViD			
		H.264 / AVC	Main Profile@ Level 4.1 High Profile@ Level 4.1 (eg. 720p60, 1080i60, 1080p30)	
Audio	MPEG-1 Layer I, II MPEG-1 Layer III(MP3) AC-3			
	Video	H.264 / AVC	Main Profile@ Level 4.1 High Profile@ Level 4.1 (eg. 720p60, 1080i60, 1080p30)	Global motion compensation or quarterpel motion estimation does not supported. Streams using this syntax are not supported.
MPEG-4 Part 2		Advanced Simple Profile (eg. 720p/1080i)		
Audio		AAC	AAC-LC and AAC-HE	
.mp4 .m4a .m4v	Video	H.264 / AVC	Main Profile@ Level 4.1 High Profile@ Level 4.1 (eg. 720p60, 1080i60, 1080p30)	Most of the MKV content available is encoded by the open source x264 codec.
		MPEG-4 Part 2	Advanced Simple Profile (eg. 720p/1080i)	
.mkv	Audio	AAC	AAC-LC and AAC-HE	
		AC-3		
.ts .trp .tp	Video	H.264 / AVC	Main Profile@ Level 4.1 High Profile@ Level 4.1 (eg. 720p60, 1080i60, 1080p30)	Only streams compliant to SMPTE 421 M VC-1 standard are supported.
		MPEG-2	Main Profile@High Level(eg. 720p60, 1080i60)	
		VC-1	Simple Profile@Medium Level (eg. CIF, QVGA) Main Profile@High Level (eg. 1080p30) Advanced Profile@Level3 (eg. 720p60, 1080i60, 1080p30)	
	Audio	MPEG-1 Layer I, II MPEG-1 Layer III(MP3) AC-3		
		AAC	AAC-LC and AAC-HE	
.vob	Video	MPEG-1	Main Profile@High Level (eg. 720p60, 1080i60)	
		MPEG-2		
	Audio	AC-3 MPEG-1 Layer I, II DVD-LPCM		
.mpg	Video	MPEG-1 MPEG-2	Main Profile@High Level (eg. 720p60, 1080i60)	Only streams compliant configured properly for TS, PS or ES
	Audio	MPEG-1 Layer I, II		

Movie Selection and Popup Menu

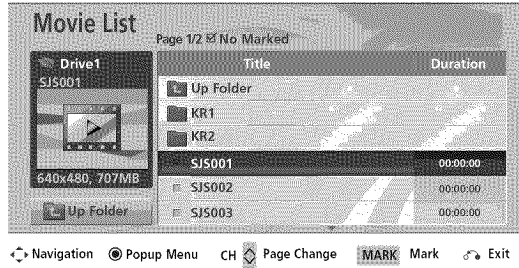



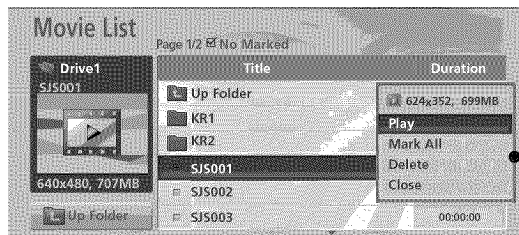



Navigation Popup Menu CH Page Change MARK Mark Exit



Navigation Popup Menu CH Page Change MARK Mark Exit

- ▶ **Play:** Play the selected file.
Dix Play is executed while the screen changes. When you select "Network", you can only listen to the music files in a shared folder on a PC. When you select "Drive" you can only listen to the music files from a USB drive.
- ▶ **Play Marked:** Play the selected file. Once a movie finishes playing, the next selected one will be played automatically.
- ▶ **Mark All:** Mark all files in the folder.
- ▶ **Unmark All:** Deselect all marked movies.
- ▶ **Delete or Delete marked (USB file and FAT32 file system only):** Delete the selected file.
- ▶ **Close:** Close the pop-up menu.

- 1  Select the target folder or drive.
- 2   Select the desired movies.
- 3  Show the Popup menu.
- 4   Select the desired Popup menu.

- Use the CH ^ v button to navigation in the movie page.
- Use the MARK button to mark or unmark a movie file. When one or more movie files are marked, the marked movie files will be played in sequence.





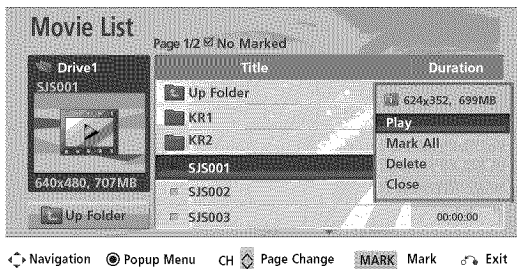
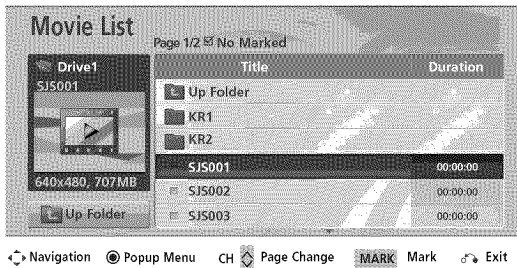

Playing the Movie

You can adjust various method during the movie play.









Display the DivX Banner in the top of the screen.



- 1  Select the target folder or drive.
- 2   Select the desired movies.
- 3  Show the Popup menu.
- 4  Select Play.
- 5  Display the current movie status progress bar in the bottom of the screen.

Using the remote control

- | | |
|---|---|
|  | Press it to rewind. |
|  | Press it to forward fast. |
|  | Displayed the still screen. |
|  | Stopped the screen. |
|  | Move to a specific frame forward or backward while playing a movie. A cursor indicating the position can be viewed on the screen. It may not work properly for some files while playing a movie.) |
|  | Displays a slow motion. |

Option Menu Selection

During the movie play, the following options are available.

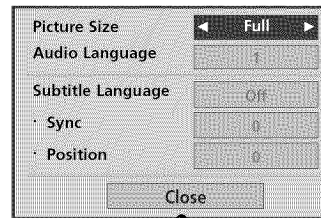

- ▶ **Picture Size:** Select the Full screen or Original size.
- ▶ **Audio Language:** Select the language.
But, the file with only one audio can not be selected.
- ▶ **Subtitle Language:** The subtitles can be turned on or off.
If there are two or more subtitles, you can select one of them.

Subtitle Language Group	Supported Language
Latin1	English, Spanish, French
Korean	English, Korean

- .**Sync:** When the video is not synchronized with the captions, it can be adjusted by 0.5 second.
- .**Position:** Move the location of the subtitle.



1 Select Option.

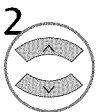

2 Select Picture Size, Audio Language, Subtitle Language, Sync or Position.

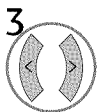

3 Select the desired option.



4 Return to movie viewing

NETCAST



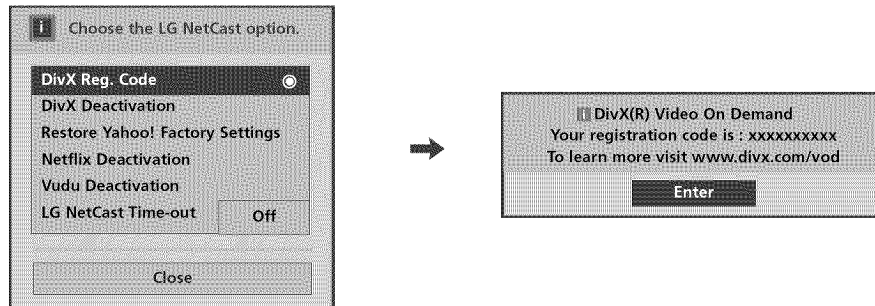

DivX Registration Code

Confirm the DivX registration code number of the TV. Using the registration number, movies can be rented or purchased at www.divx.com/vod.

With a DivX registration code from other TV, playback of rented or purchased DivX file is not allowed. (Only DivX files matched with the registration code of the purchased TV are playable.)



NETCAST

-  1 Display NetCast menu.
-  2 Select NetCast option.
-  3 Select DivX Reg. Code.
-  4 Display DivX Reg. Code.

NOTE





- ▶ When loading, some buttons may not work.
- ▶ If you use the DivX registration code of another device, the rented or purchased DivX file cannot be played. Therefore always use the DivX registration code assigned to this product.
- ▶ The video or audio of a file converted based on a standard other than the DivX codec standard may be corrupted or unable to be played.

Deactivation

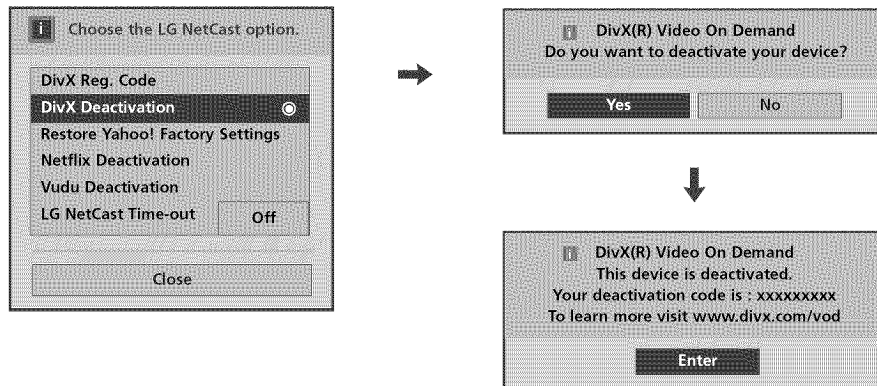
The purpose of deactivation is to allow deactivation of devices for users who have activated all the available devices through the web server and are blocked from activating more devices. DivX VOD allows the consumer to activate up to 6 devices under one account.

Delete the existing authentication information to receive a new DivX user authentication for TV. Once this function is executed, a DivX user authentication is required again to see DivX DRM files.

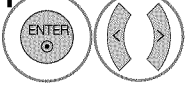

-  1 Display **NetCast** menu.
-  2 Select **NetCast** option.
-  3 Select **Deactivation**.
-  4 Select **Yes**.
-  5 Display **Deactivation**.



YouTube is a video sharing website where users can upload, view, and share video clips.

YouTube Screen Components

- 1 YouTube menu
- 2 Videos list
- 3 Period options: If you select the **Most Viewed** or **Top Rated** in the YouTube menu, the period options appear at the bottom of the screen

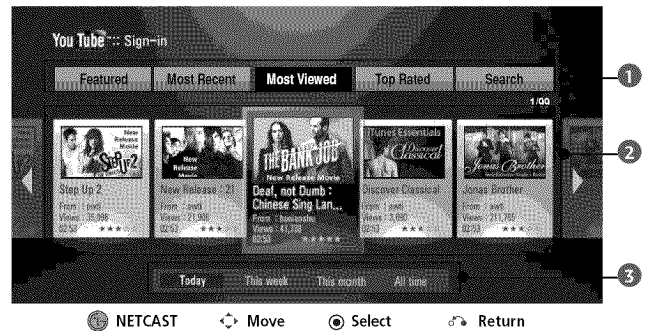

YouTube menu

Featured: The featured videos list will be displayed.

Most Recent: The most recently updated videos list will be displayed.

Most Viewed: The most viewed videos list will be displayed. The period option appears at the bottom of the screen.

Top Rated: The best rated videos list from YouTube server will be displayed. The period option appears at the bottom of the screen.

Search: The keyboard menu will be displayed.

History: The videos list that you previously played will be displayed. Maximum of 20 videos can be stored.

Favorites: In sign-in status, this menu will be displayed the videos list that is arranged in the YouTube server with your account (Some videos may not appear on the **Favorites** list, even if the videos are arranged in the server). In sign-out status, you can add the video to **Favorites** using GREEN button on the remote control.

Sign in (Sign Out): Displays the keyboard menu to sign in or returns to the sign-out status.

Local Setting: Choose which country's videos you would like to view. The countries listed on the Local Setting menu may differ with those listed on the YouTube web site.

NOTE

- ▶ The videos list searched from the TV may differ with the list searched from a web browser on PC.
- ▶ The settings of this TV do not affect the YouTube's playback quality.
- ▶ The playback of YouTube videos may be paused, stopped or buffering occurring often depending on your broadband speed.

We recommend a minimum connection speed of 1.5 Mbps. For the best playback condition, a connection speed of 4.0 Mbps is required. Sometimes your broadband speed varies based on your ISP's network conditions. Contact your ISP if you have problems maintaining a fast connection that is reliable, or if you want to increase your connection speed. Many ISPs offer a variety of broadband speed options.

YouTube playback

While watching a video from YouTube via TV, you can control the YouTube video playback. You can use the buttons on the remote to pause and resume viewing.

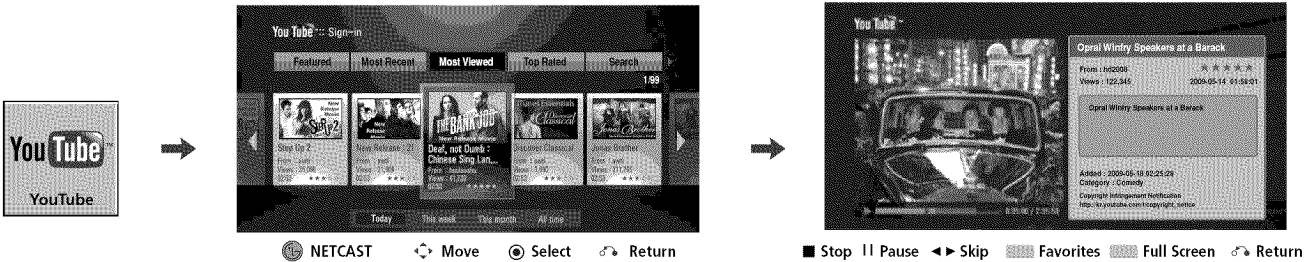

- 1 Select **YouTube**.
- 2 Select the desired YouTube menu.
- 3 Update the video list for the selected YouTube menu.
- 4 Select the desired video.
- 5 Starts playback the video with content detail.
- 6 Return to previous menu.

Using the remote control

	Stops the video and displays related videos list.
	Pause the video while it is playing.
	Skip the playback forward or backward.
	Set the favorite video.
	Toggle between playback in full screen and playback screen with content detail.

when the playback ends or stops

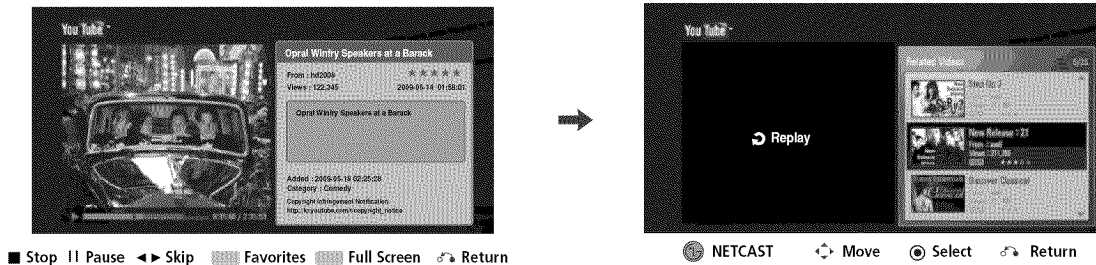



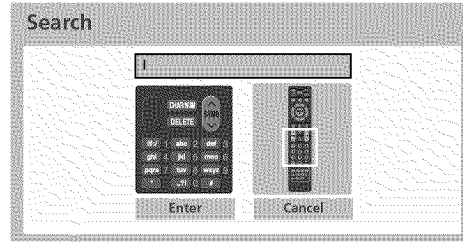
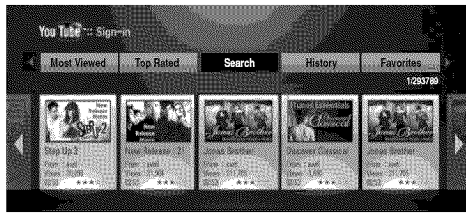

- 1 Select the current video or a video from the related videos list.
- 2 or Play the selected video.

Searching videos

You can search for videos by entering search words of up to 128 characters.









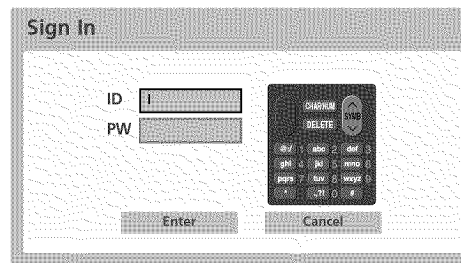
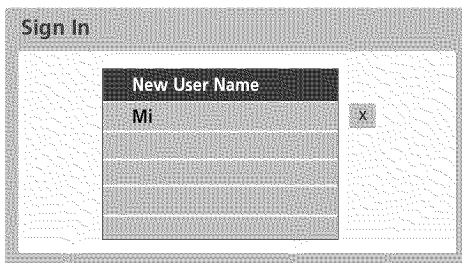

- 1   Select **Search**. It displays the keyboard menu.
- 2  Select a character.
When you entering a character, maximum of 5 suggestion words will be displayed.

- 3   Select **ENTER** to display the related videos list when you finish entering the search words.

Sign in with your YouTube account

To watch videos from your **Favorites** video list on the YouTube server with your account, you need to sign in with your YouTube account.









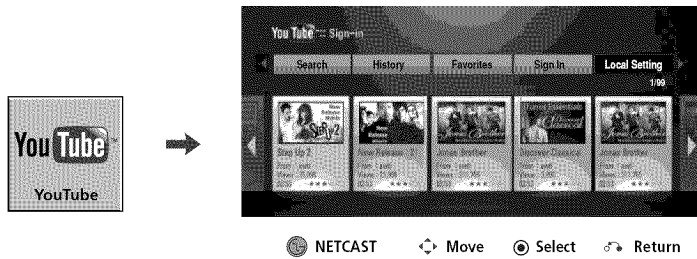

- 1   Select **Sign In**.
- 2   Select **New User Name**.
It displays the keyboard menu for entering a new ID and password.
X: Delete the stored ID as shown left of the X symbol.
- 3  Select a character.
- 4   Select **ENTER** to confirm your selection on the keyboard menu.
If you want to sign out, select the **Sign Out** from the YouTube menu and press ENTER.

■ This TV can automatically store up to 5 IDs which were previously signed-in. The IDs list appears when you select the **Sign In**. Select a stored ID on the list and press ENTER to display the keyboard menu with the selected ID is entered. You will only need to enter the password to sign in.

Local Setting







Choose which country's videos you would like to view. The countries listed on the Local Setting menu may differ with those listed on the YouTube web site.



- 1    Select YouTube.
- 2    Select Local Setting.
- 3   Select the desired country.

NETCAST TIME-OUT SETTING



- 1  Display NetCast menu.
- 2  Select NetCast option.
- 3   Select LG NetCast Time-out.
- 4    Select the desired time-out option.

NETCAST



VUDU Home Menu

- 1 Select Watch HD Movies.
- 2 Select desired menu option.
- 3 Return to the Netcast menu.
 Exit Vudu.



Featured Titles

- Poster strip with approximately 20 posters
- Highlighting the poster reveals more information about the movie such as quality, pricing and availability.
- Availability to view is subjected by Parental Control setting. For example, if Parental Control is set to not show R rated movies, then the Poster strip will not show any R rated movies (even they are in the original lists).

Remote Control Help

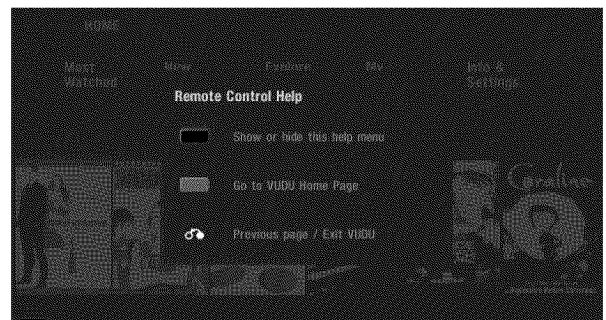

- 1 Select Watch HD Movies.
- 2 You can see the Remote Control Help.
Use each button depending on your purpose.

Activating the TV

In order to make rental/purchase transactions on the Vudu service, a user must create an account on vudu.com. That account is linked to a specific device, via a process called “activation”. It is possible to have multiple devices associated with a single Vudu account.

If newer software is needed, a software update screen will automatically appear (Refer to P.68).

Note that this service is provided by the Content Provider, Vudu. It is dependent on Vudu to provide the data.

- 1 Visit the Vudu website on your computer:
www.vudu.com/activation
Enter your Sign in Name and Password to log into your account.

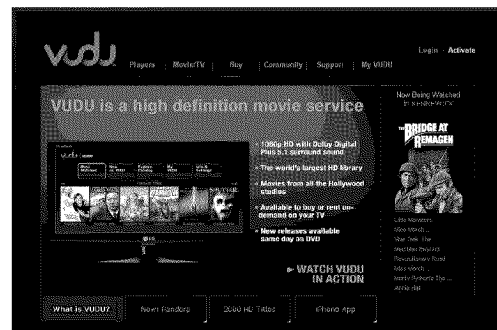

- 2 See the activation code on your TV screen,

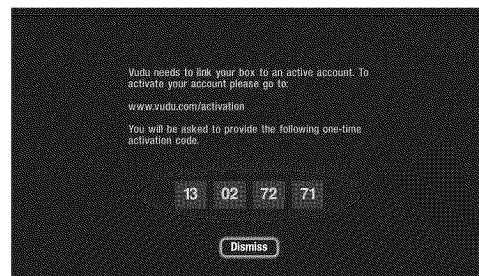

Enter this activation code to the Vudu Website and click **Activate Device**.



Vudu Deactivation

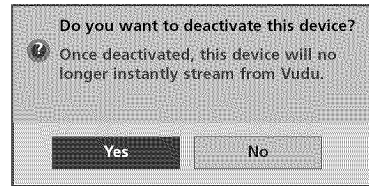

1 Display NetCast menu.

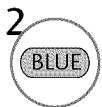

2 Select NetCast option.

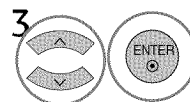

3 Select Vudu Deactivation.

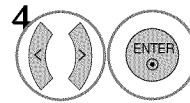

4 Select Yes to deactivate the TV.

Most Watched

This is the list of top 100 movies based on VUDU users recent transactions.

The list has the following characteristics:

- Most frequently watched title is sorted with most frequently watched at the top of the list.
- When the cursor moves to a title, there is a number overlay indicating the ordering number on the list.
- The list is dynamically adjusted based on the MPAA rating filter (i.e. If you choose a G rating movie, the list will show the top 100 watched movies which contain only G rating and below.)

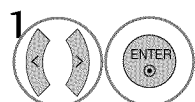
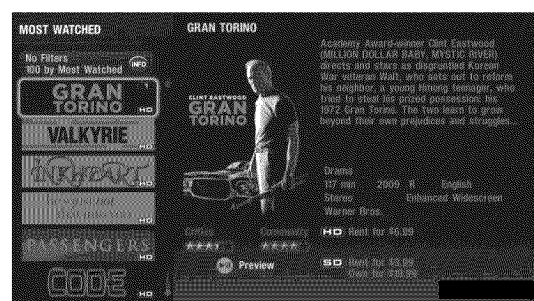

1 Select Most Watched.



2 Select the desired movie.
You can view details for the selected movie.

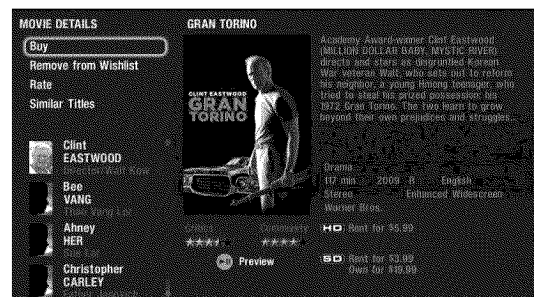

Movie Details

Movie Rental /Purchase

1  On **MOVIE DETAILS** screen, select **BUY**.

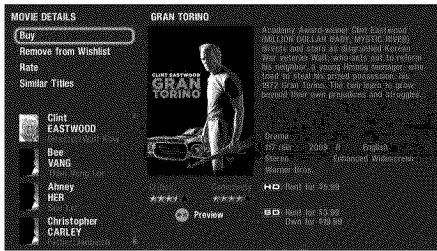

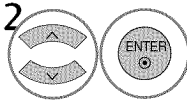
2  Select quality level and purchase type (rent or own). Availability of quality levels and purchase types may differ on a per-title basis.

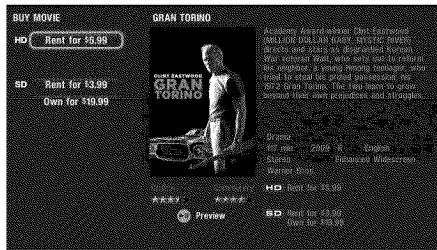

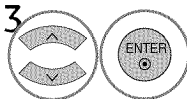
3  Confirm the purchase or rental on the confirmation screen.



4  Selection option to **Watch Now** or **Watch Later**.



Add/Remove Wishlist

Add to Wishlist: You can choose to add the movie into Wishlist.

Remove to Wishlist: The movie can be removed from Wishlist.

1  On **MOVIE DETAILS** screen, select **Add to Wishlist** or **Remove from Wishlist**.

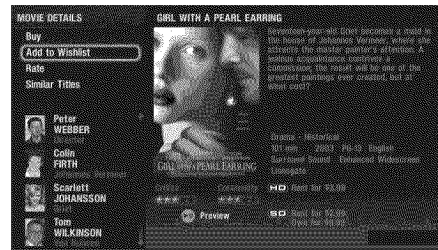

2 You can check your wishlist on **My Wish List** menu.

NETCAST

Rating Selection

You can rate VUDU movies from 1/2 star to 5 stars. These ratings are aggregated into a VUDU community rating which is reflected in Movie Details.

1  On **MOVIE DETAILS** screen, select **Rate**.

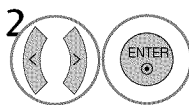

2  Select the desired star ratings.

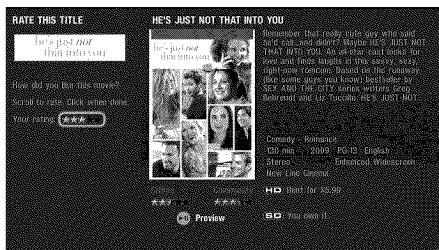

Similar Titles

In any movie, Vudu offers an option for users to find out more about movies that are similar to the selected movie.

1  On **MOVIE DETAILS** screen, select **Similar Titles**.

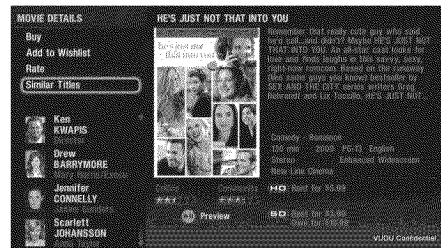

2  Select desired movie.

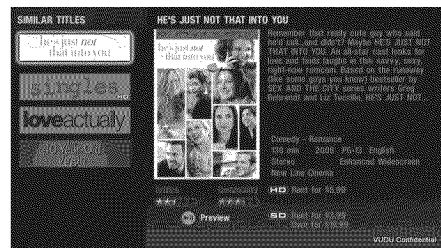

Filtering and Sorting

Vudu offers this filtering and sorting to filter out unwanted results or sorting in the your preferred order in order to find the result quickly.

In any list, you can look for the top left to find the **Filter and Sort** to select and narrow down the result.



Display the filter and sort.



Filtering

The result for filtering will be the AND product of all of the selected filters.

- By Genre: You can choose to filter the result by genre to get only the result in a specific category of movies. The user may only select one genre per this kind of filter.
- By MPAA Rating: You can choose to filter by MPAA rating which is appropriate for the target of viewers. There is only one rating can be chosen for this filter.
- By Critics' Rating: The critics rating filter helps you to narrow down the result in term of star rating.
- By Studio: Studio is one of the important criteria for filtering result. As often some studio is more family friendly then the others or some studio is more international oriented. Since the list of studio is also very large, Vudu offers to filter only the major Hollywood studios.

Sorting

- By Top Picks: Top Picks is the Vudu's editorial ranking for a particular movie. The sort order is descending or best recommended movie at the top.
- By Most Watched: You can choose to sort the list as Most Watched. The sort order is to have the Vudu service most watched movie at the top.
- By Critics' Rating: You can sort by critics' rating. The sort order is to have the higher star rating at the top.
- By Release Date: You can sort by release date to quickly find out the most recent movie in the list result. The sort order is the most recent at the top.
- A through Z: This sort is pure alphabetic sorting. Note: "The" will not affect the sort result. i.e. "The 11th Hour" would go before the movie "12 Angry Men".

New on Vudu

VUDU can inform about availability of recent added movies.

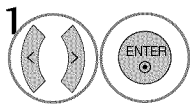

1 Select **New on Vudu**.

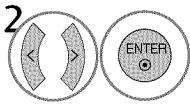

2 Select desired menu option.

- **New to Rent:** It lists titles newly available to rent on the VUDU service.
- **New to Own:** It lists titles newly available to purchase on the VUDU service.
- **All New Titles:** It lists all titles new to the VUDU in the last 30 days, for rental or purchase.
- **Coming Soon:** It lists titles coming to the service within 30 days.

It shows upcoming movies not yet available on Vudu service for rental or purchase. You can browse this list to be aware of when Vudu can offer the new releases with specific rent and own dates. Often times, you use this list to add the new release into My Wish List

Explore Catalog

You can choose to explore Vudu contents by browsing this catalog. Vudu offers genre, HD and TV as three main categories for the user to quickly find what to watch.

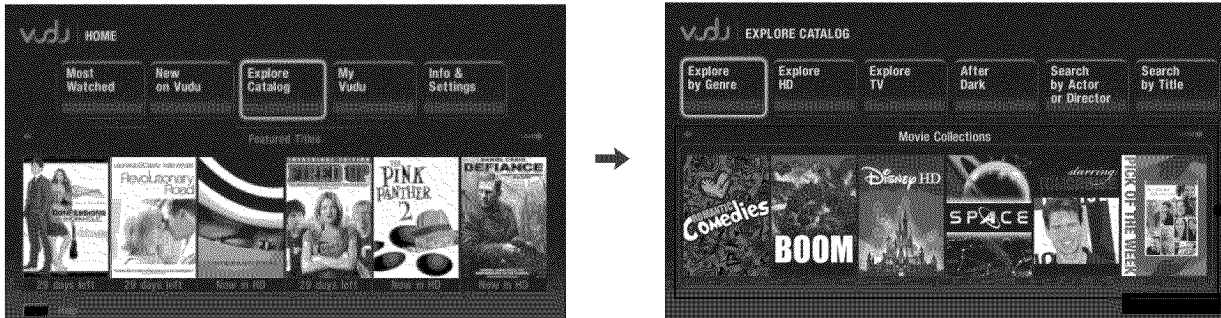

- 1    Select **Explore Catalog**.
- 2    Select desired menu option.

Movie collections

- The order of display on the poster strip cannot be changed and predetermined by VUDU service.
- The collection list itself is not rated. That means there is no way for the user to hide any collection list.
- The content of each collection list can be hidden for each user depending on Parental Control setting.

Explore by Genre

It allows you to limit your search to movies that fall within a chosen genre. After you have picked one genre, you might wish to further refine your search by choosing another. You may select as many genres as you'd like. This is an inclusive search, so each successive genre addition yields a smaller and smaller pool of movies.

VUDU currently uses 16 genres to classify its movies. Genres are determined by VUDU, while we receive metadata, including our critics' ratings, from AMG (All Movie Guide).

Once you have searched by one or more genres, you might wish to filter the results using the following available criteria: Release Date (allows you to designate time periods), MPAA Rating (allows you to designate ratings categories), Critics' Rating (allows you to designate a minimum "star" rating, e.g., 3 stars), Studio (allows you to designate a particular studio), Language (allows you to designate a particular language), Available to Rent (limits selections to those titles available to rent), Available to Own (limits selections to those titles available to own), or High Definition (limits selections to HD content).

Once you have added as many filters as you wish, you may then choose to sort your results, viewing them by Most Watched, Critics' Rating, Release Date, or A through Z.

Explore HD

It allows you to scroll through high-definition content.

Since Vudu's HD library is considered to be the largest and Vudu is known for its HD/HDX quality, Vudu users often concentrate on this particular quality to find a good suggestion for movie to watch.

Vudu offer Filtering and Sorting to help to narrow down the result

Explore TV

You can find all TV shows which are offered on Vudu service. The information is displayed as a hierarchy with series, season and episode.

Search by Actor or Director

This search is offered to users who have particular interest in movies that contain a particular cast member. The search result would show a list of movies which include the search name as a director, producer, actor, script writer, and other cast member.

It allows you to spell out an actor or director's name using the on-screen keyboard with your remote control. You may search by first or last name.

Search by Title

This search is offered to users who are interested in a specific movie name.

It allows you to spell out the title of the film for which you are searching using the on-screen keyboard with your remote control.

After Dark

You can control on how to access to Adult contents or how easily you can get into After Dark.







Vudu has Adult Content offering via After Dark menu, taking into account privacy and parental controls concerns.

You can choose to enter After Dark (upon Adult agreement via web account box management). This is completely isolated and discrete.

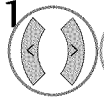
Hiding After Dark from Explore Catalog

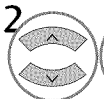
Use this feature to hide the **After Dark** under Explore Catalog. **After Dark** will not be shown with the Explore Catalog any more. However you still can reactivate it under Parental Control.

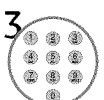
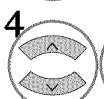
If Adult is enabled, you still can get into After Dark by going through Parental Control - **Go to After Dark**.

-   Select **Info & Settings**.
-   Select **Adult Settings**.
-  Input the passcode.
-   Select **Hide button**.

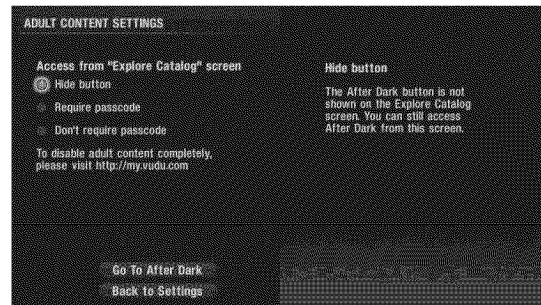
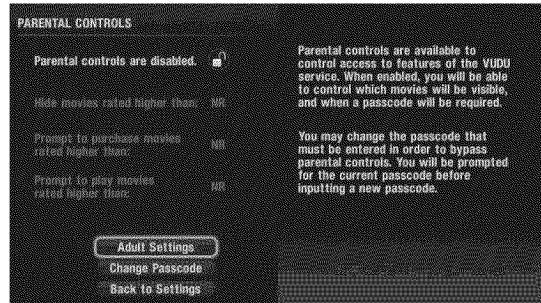

Show button but require passcode

You can choose to show the **After Dark** in Explore Catalog but will have to enter the passcode every time to enter.

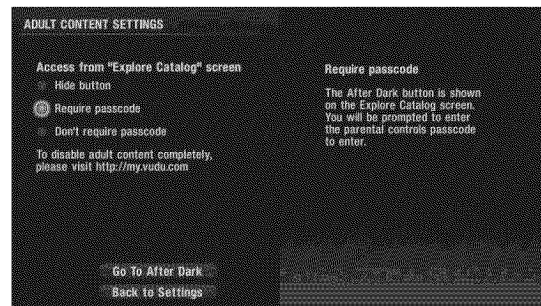

Show button and no passcode required

You can have **After Dark** without any passcode protection. The **After Dark** will be shown in Explore Catalog, and entering it will not have to be challenged by any passcode.

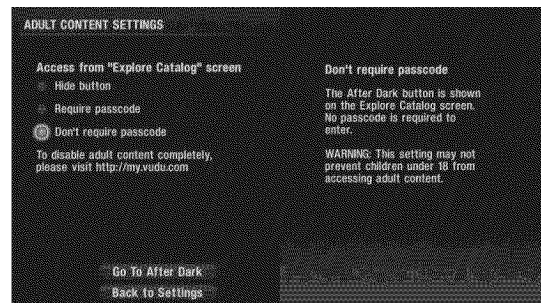

Go to After Dark

This is considered to be the backdoor or most discrete way to have access to After Dark.

My Vudu

You can find out about the ownership of purchased or rented movies or the personalized Wish list.

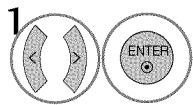
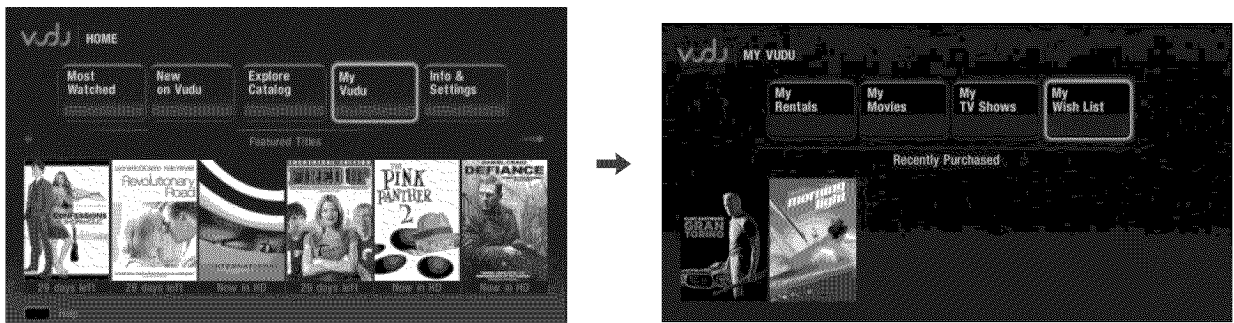

Select My Vudu.

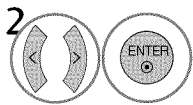

Select desired menu option.

- **My Rental:** It lists your active rentals on the service.
- **My Movies:** It lists movies you own.
- **My TV Shows:** It lists your purchased TV shows.
- **My Wish List:** As you are exploring VUDU's catalog, you may come upon a movie or TV show that you'd like to rent or buy but not straight-away. My Wish List allows you to flag that title as a reminder - just select "Add to Wish List" on the title's Movie Details or Episode Details screen.

Info & Settings

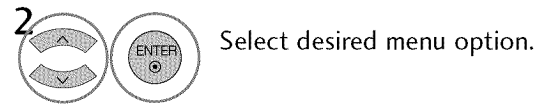
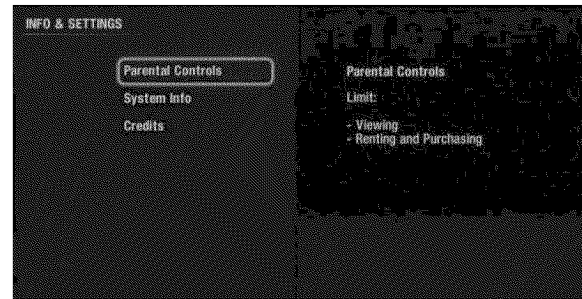

Parental Controls

Vudu has a flexible parental control feature which controls the MPAA rating levels to control browsing, purchasing, and viewing as separate settings.

Most movies are assigned a rating by the MPAA, the Motion Picture Association of America.

Set up passcode for first use:

Upon the first attempt to enable parental control, you will be asked to enter passcode.

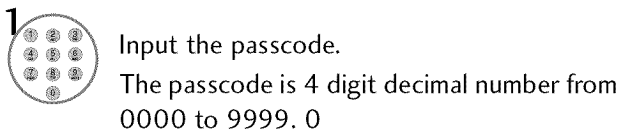

- The TV is set up with the initial password "0-0-0-0".

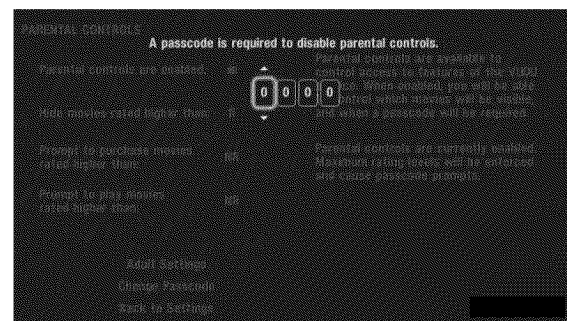
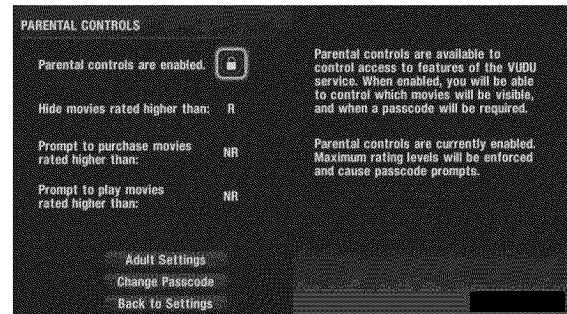

To enable or disable Parental Control

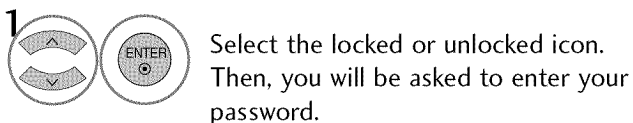

- When you return to Parental Controls in the future and wish to make a change in your settings, you will be asked for your password. Should you forget your password, please call Customer Care at 1-888-554-VUDU (8838).

Blocking browsing based on MPAA rating

This function has the ability to hide movies with MPAA ratings higher than a given setting anywhere in Vudu, including My Movies.

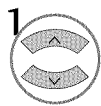
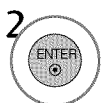
- 1  Select **Hide movies rated higher than**.
- 2  Select block options.

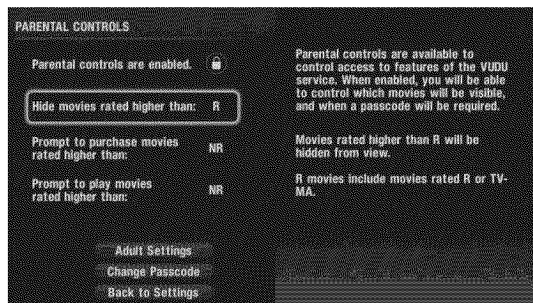

Blocking purchase based on MPAA rating

Use this option to control the purchase of unwanted content without passcode authorization.

Once this option is set, every purchase of any movie which is higher than the MPAA level will require entering passcode.

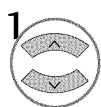
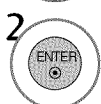
- 1  Select **Prompt to purchase movies rated higher than**.
- 2  Select block options.

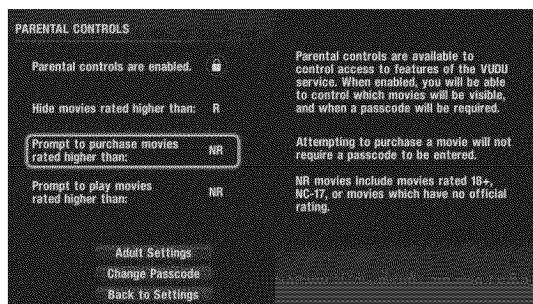

Blocking player based on MPAA rating

When this option is turned on, before playing any movie which has MPAA rating higher than the parental control setting, you will have to enter the passcode.

Once this option is set, every playing of any movie which is higher than the MPAA level will require entering passcode.

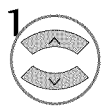
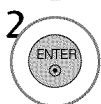
- 1  Select **Prompt to play movies rated higher than**.
- 2  Select block options.

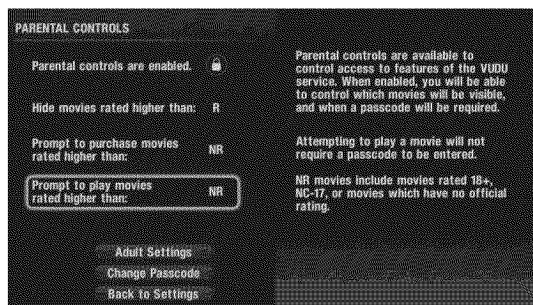

- G: G movies include movies rated G, TV-G, or TV-Y7.
- NR: NR movies include movies rated 18+, NC-17, or movies which have no official rating.
- R: R movies include movies rated R or TV-MA.
- FAM: FAM movies include movies which have no official rating, but are family-friendly.
- PG-13: PG-13 movies include movies rated PG-13 or TV-14.
- PG: PG movies include movies rated PG or TV-PG.

Changing passcode

You can select this menu to change the current passcode. Just like any other password changing method, you need to know the current passcode in order to change it to a newer one.

Convenience passcode timeout

The purchasing and play function have a “time-out” of 5 minutes, meaning if you leave the screen idle for more than 5 minutes, you will be asked the passcode.

System Info

You can find your Device ID, UI Version and etc.

Credits

It contains credits to technology licensees and data providers.

Theater Mode

Quality Fall Back

Vudu has video quality fall back to make sure you can experience the best possible video quality with your home network bandwidth. Vudu has option to allow you to downgrade video quality for free if the home network suddenly suffers from heavy network traffic. (i.e. you can rent HDX quality and can choose to stream at lower quality such as HD or SD if network bandwidth drops to make sure the viewing experience is as smooth as possible.)

Auto detection and suggestion

If the network is suffering heavy traffic, and the buffering (loading) messages have to show up 4 times, the software would suggest that you to download the quality to ensure continuous viewing. You have option to keep on trying the highest quality that you have purchased.

It depends on the quality of purchased movie, and Vudu's availability to suggest the other option to stream. (i.e. the movie was bought as HDX and Vudu has other HD and SD quality then both lower quality will be offered)

i.e.



Trick Info

- 1  Show a brief movie info (movie title, video quality (SD/HD/HDX), and streaming bit rate level (represented by quality bars) within the given quality level).



Manually switching for movie quality

You may choose to view at lower quality of your choice at beginning due to past experience or other home device network demand.





The Movie Info will show option to downgrade quality based on: the purchased quality of the movie, and the availability of other quality from Vudu service. (i.e. a HDX movie would commonly see the offering of HD and SD movie for "Switch Quality".)

You can chose any available quality to downgrade free of charge.

- 1     Select a desired movie quality: HDX, HD, or SD.



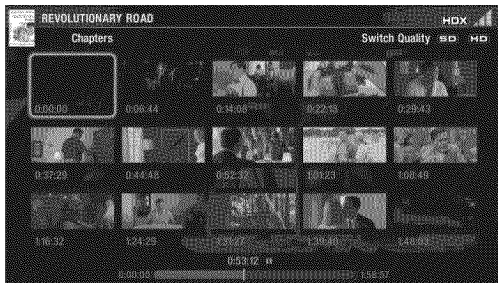

Frame selection directly

- 1    Select **Chapters**. It shows thumbnail view of movie "chapters" with time positions.
- 2   Select the desired frame.





Trick Playback

- 1  Play the movie.
- 2  The playback is paused and it shows the Thumbnail seek mode. Move left or right frame in the strip.
- 3  Select desired frame. The progressing bar shows the time position of the current frame.



- It's possible to use **Q.MENU - TruMotion (Off, Low, High)** when using Vudu.
- Vudu supports 16:9, 4:3, Set By Program, Zoom, and Cinema Zoom aspect ratio.

Fast Forward/Backward

- 1   Enter the trick play skip mode, select the desired speed of scanning through the movie: <<<<, <<<, <<, <<, >>, >>>, >>>> speed for skipping through frames.



- 2  Start playback of the selected frame.

PICTURE CONTROL



PICTURE SIZE (ASPECT RATIO) CONTROL

This feature lets you choose the way an analog picture with a 4:3 aspect ratio is displayed on your TV.

HDMI/RGB-PC input only support 4:3 or 16:9 aspect ratio. But you can select all aspect ratios in HDMI-PC 1920X1080 input.

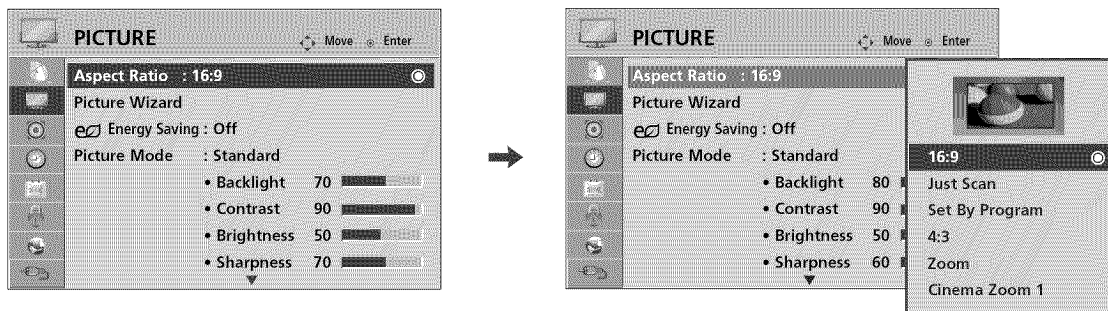
You can select a different aspect ratio depending on input source (analog broadcasting, digital broadcasting, aux).

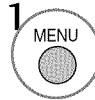
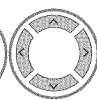
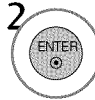
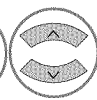
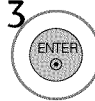
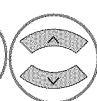

-   Select PICTURE.
-   Select Aspect Ratio.
-   Select the desired picture format.
-  Return to the previous menu.
-  Return to TV viewing.

- You can also adjust **Aspect Ratio** in the Q.MENU.
- Press the **RATIO** button repeatedly to select the desired picture format.

16:9

Adjust the picture horizontally, in a linear proportion to fill the entire screen.

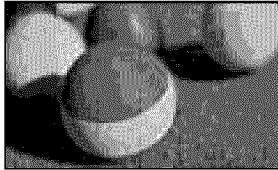

Just Scan

Normally the edges of video signals are cropped 1-2%. Just Scan turns off this cropping and shows the complete video.

Notes: If there is noise on the edges of the original signal, it will be visible when Just Scan is activated.

Just Scan operates only in DTV/CADTV/Component/HDMI-DTV/DVI-DTV (720p/1080i/1080p) input source.



Set By Program

Selects the proper picture proportion to match the source's image.

(4:3 → 4:3)



(16:9 → 16:9)



4:3

Choose 4:3 when you want to view a picture with an original 4:3 aspect ratio.

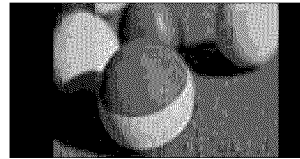

Zoom

Choose Zoom when you want to view the picture without any alteration. However, the top and bottom portions of the picture will be cropped.

- When adjusting in Q.MENU menu,
 - a. < or > button: Adjust proportion of Zoom.
 - b. ^ or v button: Move the image on the screen.

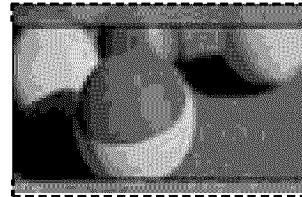

Cinema Zoom

Choose Cinema Zoom when you want to enlarge the picture in correct proportion.

This enlarges an image with cinemascope aspect ratio (2.35:1) without distortion.

Note: When enlarging or reducing the picture, the image may become distorted.

- < or > button: Adjust proportion of Cinema Zoom. The adjustment range is 1-16.
- ^ or v button: Move the image on the screen.

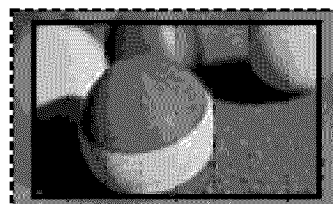

PICTURE CONTROL

PICTURE WIZARD

This feature lets you adjust the picture quality of the original image.

Use this to calibrate the screen quality by adjusting the Black and White Level etc. You can calibrate the screen quality by easily following each step.

When you adjust the image to **Low**, **Recommended** or **High**, you can see the example of the changes you made.

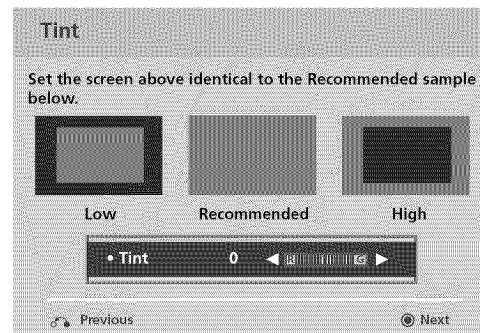
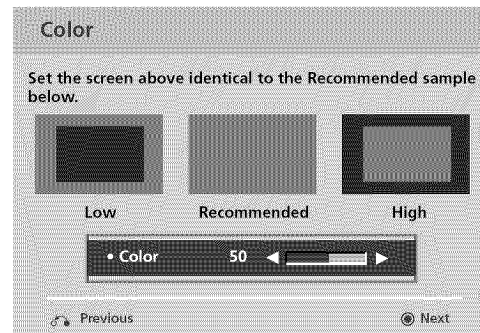
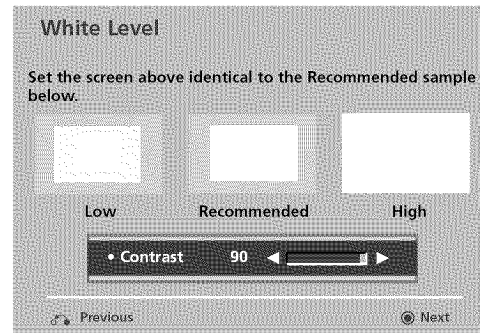
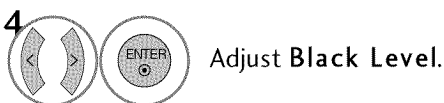
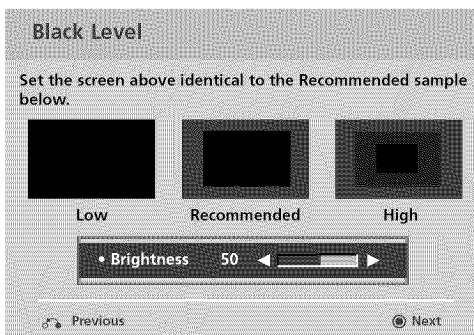
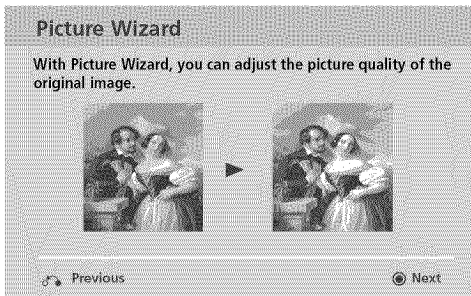
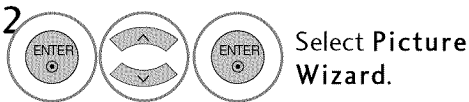
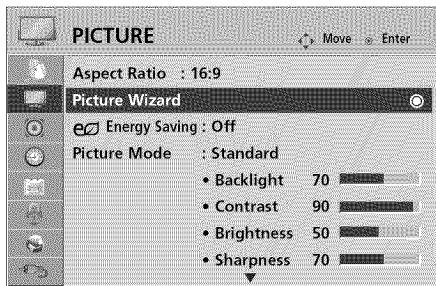

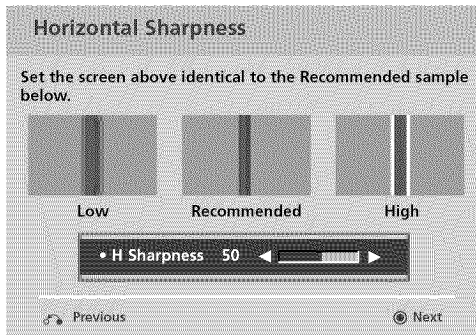

8   Adjust Horizontal Sharpness.

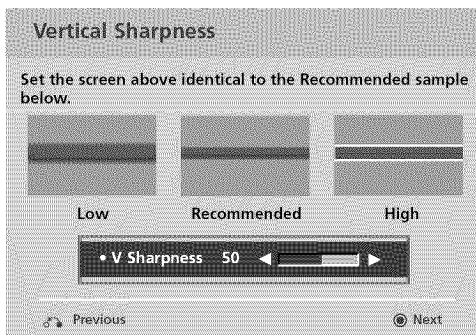

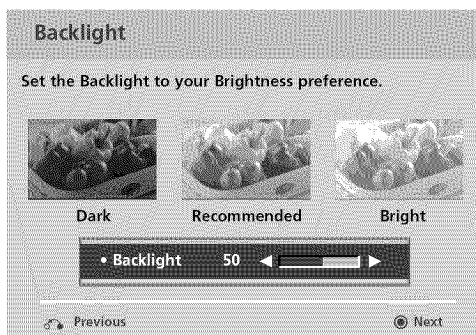

9   Adjust Vertical Sharpness.

For LCD TV



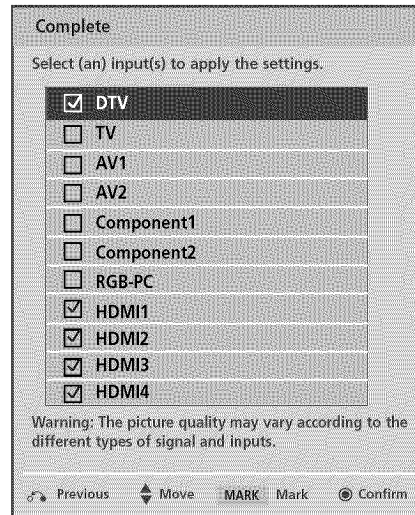

10   Adjust Backlight.

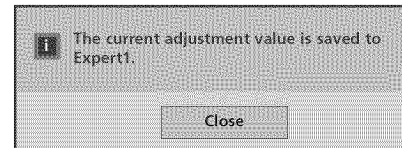

11   Select input source to apply the settings.

12  Save.



13  Finish the Picture Wizard.







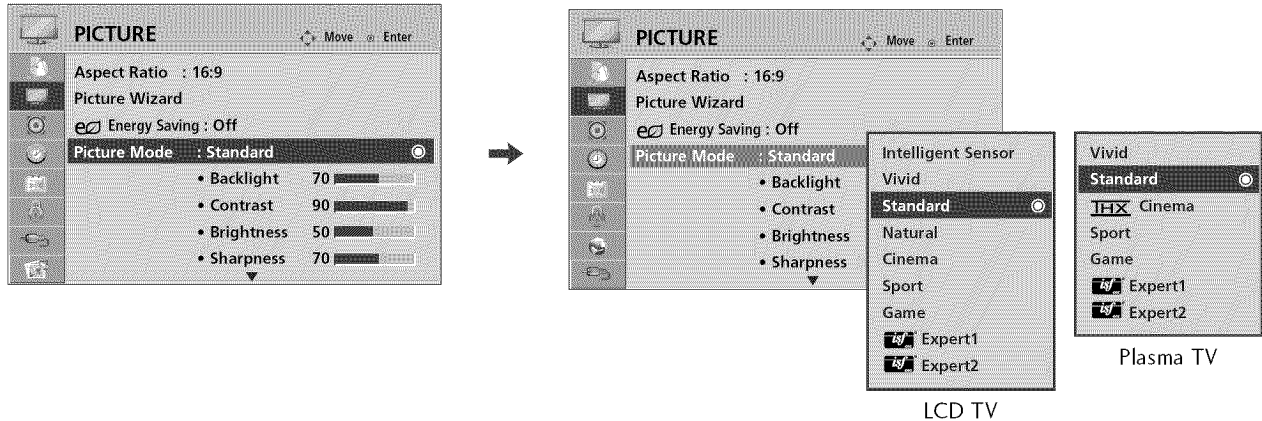

- If you stop the setting before the final step, the changes will not be saved to the TV.
- Once the **Picture Wizard** sets the picture quality, **Energy Saving** is changed to **Off** automatically (For LCD TV).

PICTURE CONTROL

PRESET PICTURE SETTINGS (PICTURE MODE)

There are factory presets for picture settings available in the user menus. You can use a preset, change each setting manually, or use the Intelligent Sensor.



- 1   Select PICTURE.
- 2   Select Picture Mode.
- 3   Plasma TV: Select Vivid, Standard, **THX** Cinema, Sport, or Game.
LCD TV: Select Intelligent Sensor, Vivid, Standard, Natural, Cinema, Sport, or Game.
- 4  Return to the previous menu.
 Return to TV viewing.









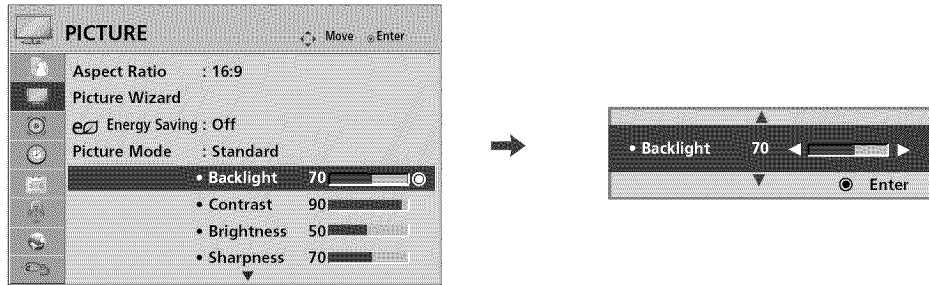



- **Vivid, Standard, Natural, Cinema, Sport, and Game** Settings are preset for the optimum picture quality at the factory.
- **Vivid:** This is the mode to maximize the effect of the video in the retail store. Strengthen the contrast, brightness, color and sharpness for vivid picture.
- **Standard:** This is the mode to realize optimum viewing condition for the general user.
- **Natural:** This is the mode to display the most natural screen status.
- **Cinema:** This mode optimizes video for watching movies.
- **Sport:** This is the video mode to emphasize dynamic video and primary color (e.g, white, uniform, grass, sky blue etc.) by realizing the optimal screen for sports.
- **Game:** This is the mode to realize fast response speed in a fast gaming screen.
- **Expert:** This is the mode to adjust the video in detail for video quality expert and general user.
- You can also adjust **Picture Mode** in the Q.MENU.

- When selecting **Intelligent Sensor**, **Energy Saving** is changed to **Auto** automatically (For LCD TV).
- When selecting **Intelligent Sensor**, it is changed contrast, brightness, sharpness, color and tint automatically (For LCD TV).
- **Intelligent Sensor:** The most suitable picture is automatically adjusted according to the surrounding conditions.
- **THX Cinema:** This is cinema quality mode to provide you the experience of watching a movie at home.
- When selecting **THX Cinema**, Aspect ratio changes to Just scan.

MANUAL PICTURE ADJUSTMENT - USER MODE

Adjust the picture appearance to suit your preference and viewing situations.
 This feature is disabled in "Picture Mode- ~~THX~~ Cinema" (For Plasma TV).



- 1   Select PICTURE.
- 2   Select Picture Mode.
- 3   Select Vivid, Standard, Natural, Cinema, Sport, or Game.
- 4   Select Backlight (For LCD TV), Contrast, Brightness, Sharpness, Color, or Tint.
- 5   Make appropriate adjustments.
- 6  Return to the previous menu.
-  Return to TV viewing.

- When adjusting Energy Saving, **Backlight** function is disabled (For LCD TV).
- **Backlight** (For LCD TV): This function adjusts the brightness of LCD panel, to control the brightness of the screen. Adjusting the backlight is recommended when setting the brightness of the set. When decreasing the backlight, the brightness of the black becomes darker without any loss in video signal and the power consumption is reduced.
- **Contrast**: Increase or decrease the gradient of the video signal. You may use Contrast when the bright part of the picture is saturated.
- **Brightness**: Adjusts the base level of the signal in the picture. You may use Brightness when the dark part of the picture is saturated.
- **Sharpness**: Adjusts the level of crispness in the edges between the light and dark areas of the picture. The lower the level, the softer the image.
- **Color**: Adjusts intensity of all colors.
- **Tint**: Adjusts the balance between red and green levels.



PICTURE CONTROL

PICTURE IMPROVEMENT TECHNOLOGY

You can calibrate the screen for each Picture Mode or set the video value according to the special video screen. You can set the video seeing differently for each input.

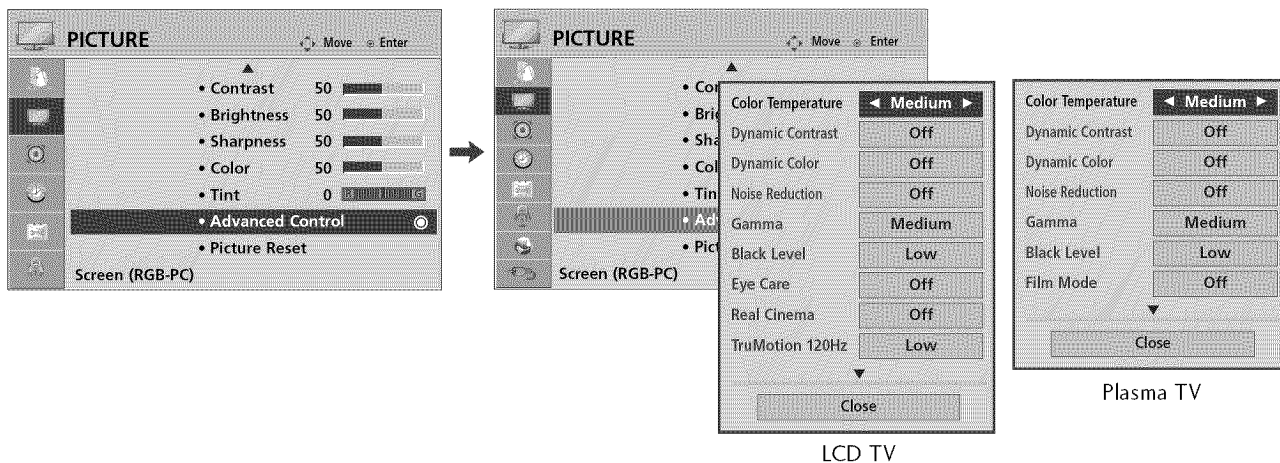
To reset to the factory default after making adjustments to each input source, execute the **Picture Reset** function for each Picture Mode.

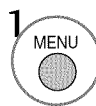

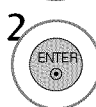
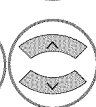
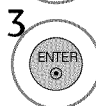
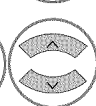
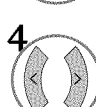
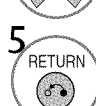
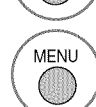







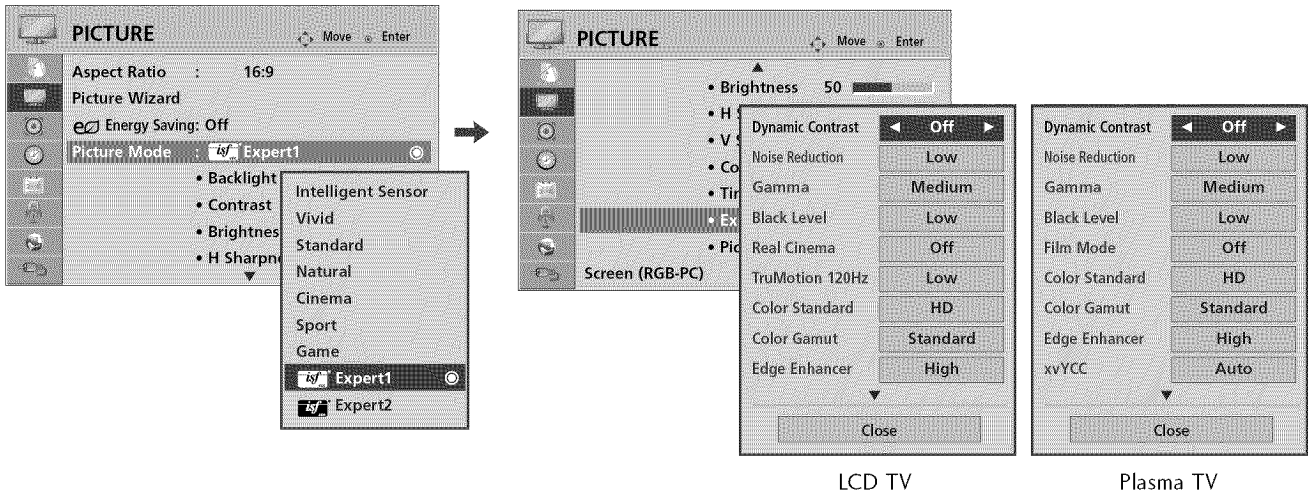







-   Select **PICTURE**.
-   Select **Advanced Control**.
-   Select your desired options.
-  Make appropriate adjustments.
-  Return to the previous menu.
-  Return to TV viewing.

EXPERT PICTURE CONTROL

By segmenting categories, **Expert1** and **Expert2** provide more categories which users can set as they see fit, offering the optimal picture quality for users.

This may also be used by a professional to help optimize the TV performance in the environment the TV is in.



- 1   Select **PICTURE**.
- 2   Select **Picture Mode**.
- 3   Select  **Expert1** or  **Expert2**.
- 4   Select **Expert Control**.
- 5   Select your desired menu option.
- 6   Make appropriate adjustments.
- 7  Return to the previous menu.
-  Return to TV viewing.

PICTURE CONTROL

Color Temperature	<ul style="list-style-type: none"> ■ Set to warm to enhance hotter colors such as red, or set to cool to enhance cooler colors such as blue.
Dynamic Contrast	<ul style="list-style-type: none"> ■ Adjusts the contrast to keep it at the best level according to the brightness of the screen. The picture is improved by making bright parts brighter and dark parts darker.
Dynamic Color	<ul style="list-style-type: none"> ■ Adjusts screen colors so that they look livelier, richer and clearer. This feature enhances hue, saturation and luminance so that red, blue, green and white look more vivid.
Noise Reduction	<ul style="list-style-type: none"> ■ Reduces screen noise without compromising video quality.
Gamma	<p><i>Low : Make dark and middle gray level area of the picture brighter.</i> <i>Medium: Express original picture levels.</i> <i>High: Make dark and middle gray level area of the picture darker.</i></p> <ul style="list-style-type: none"> ■ You can adjust brightness of dark area and middle gray level area of the picture.
Black Level	<p><i>Low: The reflection of the screen gets darker.</i> <i>High: The reflection of the screen gets brighter.</i></p> <ul style="list-style-type: none"> ■ Set black level of the screen to proper level. ■ This function is available in the following modes: AV (NTSC-M), HDMI or Component.
Eye Care (For LCD TV)	<ul style="list-style-type: none"> ■ Adjust the brightness of the screen to prevent the screen from being too bright. Dims extremely bright pictures. ■ This feature is disabled in "Picture Mode-Vivid, Cinema, Intelligent Sensor(For LCD TV)".
Real Cinema or Film Mode	<ul style="list-style-type: none"> ■ Makes video clips recorded in film look more natural by eliminating judder effect. ■ DVD and Blu-ray movies are filmed at 24 frames per second (fps). With LG Real Cinema, every frame is consistently processed 5 times in 1/24 of a second producing 120 fps with TruMotion or 2 times in 1/24 of a second producing 48 fps without TruMotion, thus totally eliminating the judder effect.
TruMotion (For LCD TV)	<p><i>High: Provides smoother picture movement.</i> <i>Low: Provides smooth picture movement. Use this setting for standard use.</i> <i>Off: Use this setting when "High" and "Low" settings result in noise.</i></p> <ul style="list-style-type: none"> ■ TruMotion works with all inputs except PC mode. ■ If you enable "TruMotion", noise may appear on the screen. If this occurs, set "TruMotion" to "Off".

Color Gamut	<p><i>Standard: Displays standard set of colors.</i> <i>Wide: Increase number of colors used.</i></p> <ul style="list-style-type: none"> ■ Maximize the utilization of color to increase color quality.
Edge Enhancer	<ul style="list-style-type: none"> ■ Show clearer and distinctive yet natural edges in of the video.
Color Standard	<ul style="list-style-type: none"> ■ Convert the color of a different video to HD color.
Color Filter	<ul style="list-style-type: none"> ■ This is the function to filter the specific colors of the video. You can use the RGB filter to set color saturation and hue accurately.
xvYCC	<p><i>*This feature is not available for all models.</i></p> <ul style="list-style-type: none"> ■ This is the function to express richer color. ■ This feature represents rich color as much as conventional video signal. ■ This function is enabled in "Picture mode - Cinema, Expert" when xvYCC signal is inputted through HDMI.
Expert Pattern	<ul style="list-style-type: none"> ■ This is the pattern necessary for expert adjustment. ■ This function is enabled in "Picture Mode - Expert" when you watch DTV.
White Balance	<ul style="list-style-type: none"> ■ Adjusts the overall color of the screen by changing the color of white. <ul style="list-style-type: none"> a. Method : 2 Points <ul style="list-style-type: none"> - Pattern: Inner, Outer - Red/Green/Blue Contrast, Red/Green/Blue Brightness: The adjustment range is -50 - +50. <i>LCD TV</i> b. Method : 10 Point IRE <ul style="list-style-type: none"> - Pattern: Inner, Outer - IRE (Institute of Radio Engineers) is the unit to display the size of the video signal and can be set among 10, 20, 30 - 100. You can adjust Red, Green or Blue according to each setting. - Luminance: This function displays calculated luminance value for 2.2 gamma. You can input luminance value you want at 100 IRE, than the target luminance value for 2.2 gamma is displayed at every 10 steps from 10 IRE to 90 IRE. - Red/Green/Blue: The adjustment range is -50 - +50. <i>Plasma TV</i> b. Method : 20 Point IRE <ul style="list-style-type: none"> - IRE (Institute of Radio Engineers) is the unit to display the size of the video signal and can be set among 5, 10, 15 - 100 Plasma TV. You can adjust Red, Green or Blue according to each setting. - Red/Green/Blue: The adjustment range is -50 - +50.
Color Management System	<ul style="list-style-type: none"> ■ As the tool used by the experts to make adjustments by using the test patterns, this does not affect other colors but can be used to selectively adjust the 6 color areas (Red/Green/Blue/Cyan/Mgt/Yellow). Color difference may not be distinctive even when you make the adjustments for the general video. <p>Adjusts Red/Green/Blue/Yellow/Cyan, Magenta.</p> <ul style="list-style-type: none"> - Red/Green/Blue/Yellow/Cyan, Magenta Color: The adjustment range is -30 - +30. - Red/Green/Blue/Yellow/Cyan, Magenta Tint: The adjustment range is -30 - +30. - This feature is disable in RGB-PC and HDMI-PC mode.
OPC	<p><i>*This feature is not available for all models.</i></p> <ul style="list-style-type: none"> ■ As the technology to reduce the power consumption while keeping the same brightness, this has the effect of reducing power consumption, improvement in contrast.

PICTURE CONTROL

ENERGY SAVING





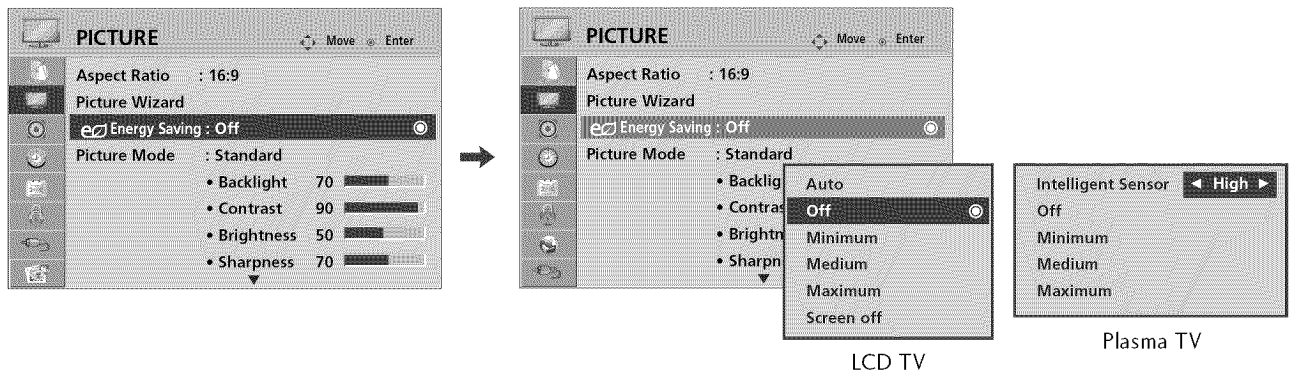

It reduces the TV's power consumption by lowering the backlight level.

The default factory setting complies with the **Energy Star** requirements and is adjusted to the comfortable level to be viewed at home.

You can increase the brightness of your screen by adjusting the **Energy Saving** level or by setting the **Picture Mode**.





PICTURE CONTROL

- 1   Select PICTURE.
- 2   Select  Energy Saving.
- 3   Plasma TV: Select **Intelligent Sensor**, **Off**, **Minimum**, **Medium**, or **Maximum**.

When selecting **Intelligent Sensor*
 Select **Low**, **Middle**, or **High**.

LCD TV: Select **Auto**, **Off**, **Minimum**, **Medium**, **Maximum**, or **Screen Off**.







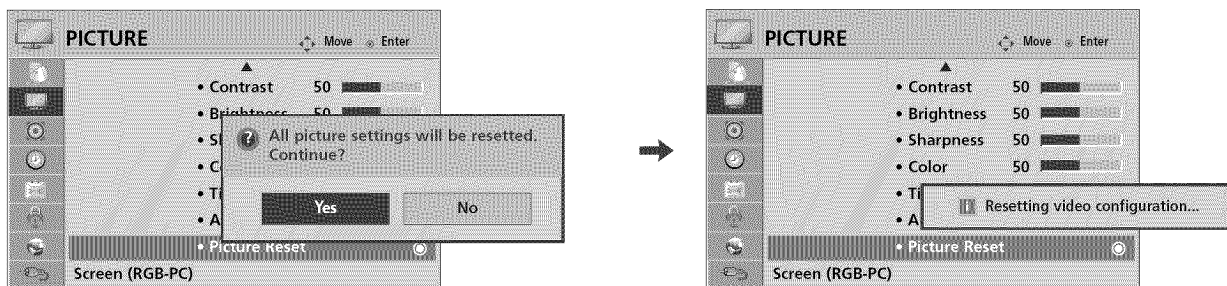

- 4  Return to the previous menu.
-  Return to TV viewing.

- When selecting **Screen off**, the TV will turn off after 3 seconds (For LCD TV).
- If you adjust "**Energy Saving-Auto** (For LCD TV), **Minimum**, **Medium**, **Maximum**", **Backlight** feature will not work.
- When selecting **Auto**, **Backlight** is automatically adjusted through **Intelligent sensor** according to the surrounding conditions (For LCD TV).
- Press the **ENERGY SAVING** button repeatedly to select the appropriate Energy Saving setup.

PICTURE RESET

Settings of the selected picture modes return to the default factory settings.









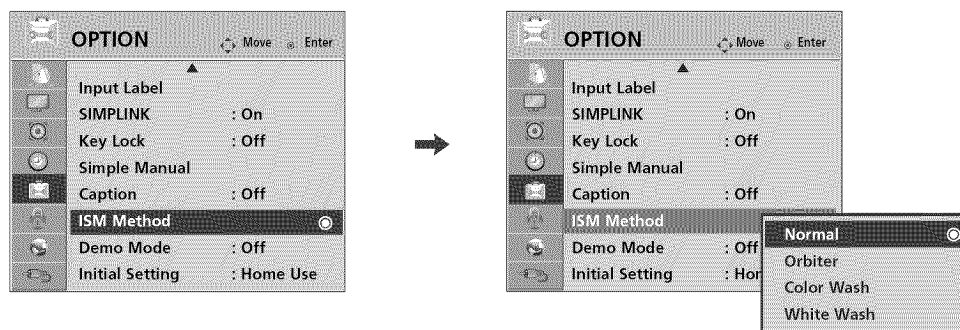

- 1   Select PICTURE.
- 2   Select Picture Reset.
- 3   Select Yes.
- 4  Initialize the adjusted value.
- 5  Return to TV viewing.

PICTURE CONTROL

IMAGE STICKING MINIMIZATION (ISM) METHOD - For Plasma TV

A frozen still picture displayed on the screen for prolonged periods can result in a ghost image. You can use Orbiter to help prevent image sticking. The other two functions are for removing a ghost image.



- 1   Select **OPTION**.
- 2   Select **ISM Method**.
- 3   Select **Normal, Orbiter, Color Wash, or White Wash**.
- 4  Return to TV viewing.

- **Normal:** If image sticking is never a problem, ISM is not necessary - set to Normal.
- **Orbiter:** To avoid a ghost image on the screen, the image will move every 2 minutes to help prevent ghost images. However, it is best not to allow any fixed image to remain on the screen.
- **Color Wash:** The color block with the screen moved a little and the white pattern are alternately displayed. It is difficult to see the after image on all colors. Once it has been corrected it will not be visible in any color.
- **White Wash:** White Wash removes ghost images from the screen. Use sparingly. Watch the TV normally for a while before using this feature to see if the ghost image disappears on its own.









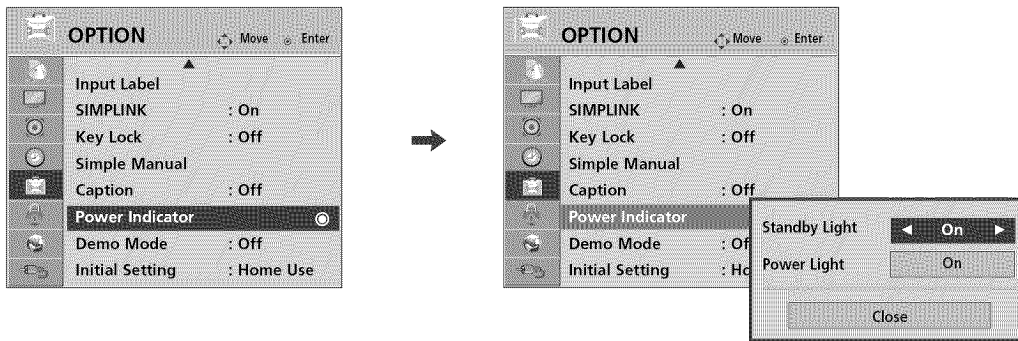

NOTE

- ▶ An excessive ghosted image may be impossible to clear entirely with White Wash. To return to normal viewing, press the any button.

POWER INDICATOR - For LCD TV

Adjust the power/standby indicator light on the front of the TV.



- 1   Select **OPTION**.
- 2   Select **Power Indicator**.
- 3   Select **Standby Light** or **Power Light**.
- 4   Select your desired options.
- 5  Return to the previous menu.
-  Return to TV viewing.

- **Standby Light:** Determines whether to set the indicator light on the front of the TV to **On** or **Off** in standby mode.
- **Power Light:** Determines whether to set the indicator light on the front of the TV to **On** or **Off** when the power turns on.







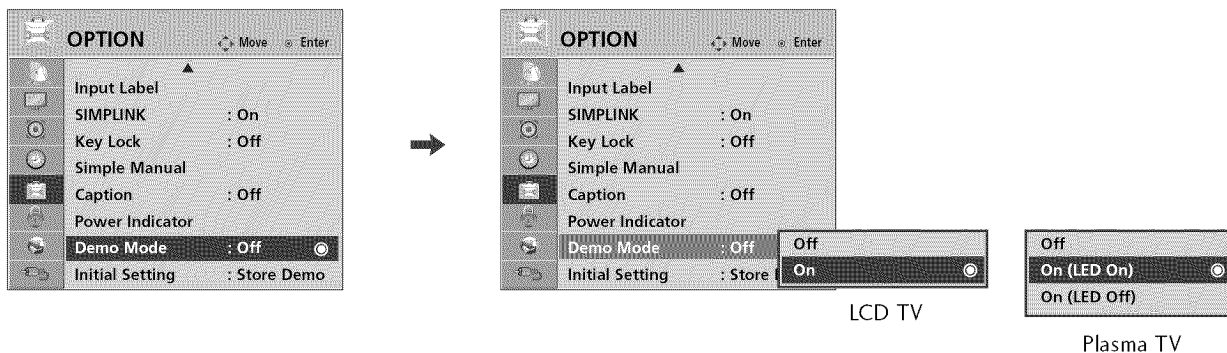

PICTURE CONTROL

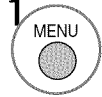
DEMO MODE

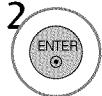
Displays a slide show to explain the various feature of this TV.

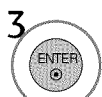

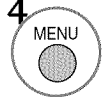
-   Select **OPTION**.
-   Select **Demo Mode**.
-   **Plasma TV:** Select **LED On** or **LED Off** to show the various feature of the TV.
LCD TV: Select **On** to show the various feature of the TV.
-  Return to TV viewing.
After a while, **Demo Mode** starts.
If you want to stop the demo, press any button (Except VOL +, - and MUTE button).

- This feature is disabled in "Initial Setting-Home Use".
- **LED On:** Turn on the LED on the TV front.
- **LED Off:** Turn off the LED on the TV front.







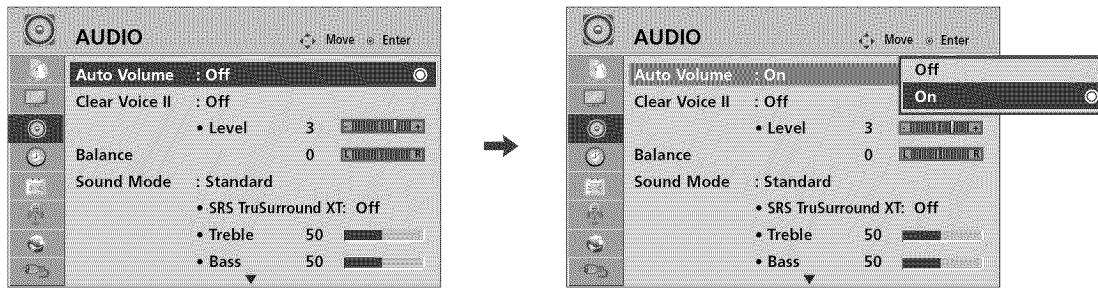

SOUND & LANGUAGE CONTROL

AUTO VOLUME LEVELER (AUTO VOLUME)

Auto Volume makes sure that the volume level remains consistent whether you are watching a commercial or a regular TV program.

Because each broadcasting station has its own signal conditions, volume adjustment may be needed every time the channel is changed. This feature allows users to enjoy stable volume levels by making automatic adjustments for each program.





-   Select **AUDIO**.
-   Select **Auto Volume**.
-   Select **On** or **Off**.
-  Return to the previous menu.
-  Return to TV viewing.



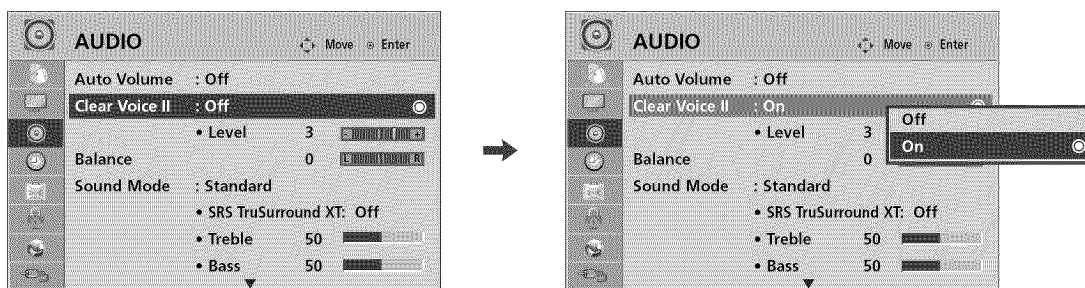

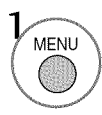
CLEAR VOICE II

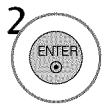
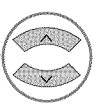
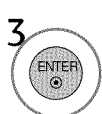
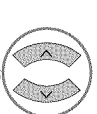
By differentiating the human sound range from others, it improves the sound quality of voices.

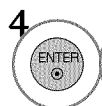

- 1   Select **AUDIO**.
- 2   Select **Clear Voice II**.
- 3   Select **On** or **Off**.

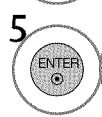
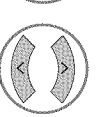

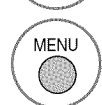



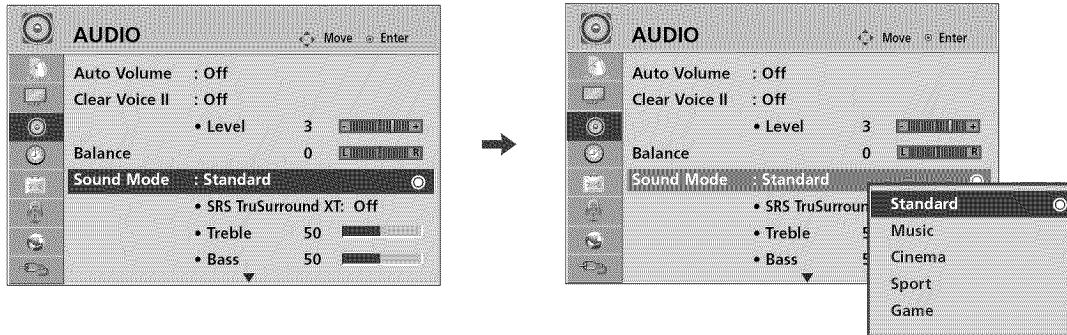

Adjustment for Clear Voice Level With selecting **On**

- 4   Select **Level**.
- 5   Make appropriate adjustments.
- 6  Return to the previous menu.
-  Return to TV viewing.

PRESET SOUND SETTINGS (SOUND MODE)

Sound Mode lets you enjoy the best sound without any special adjustment using factory presets.



- 1   Select **AUDIO**.
- 2   Select **Sound Mode**.
- 3   Select **Standard, Music, Cinema, Sport, or Game**.
- 4  Return to the previous menu.
-  Return to TV viewing.









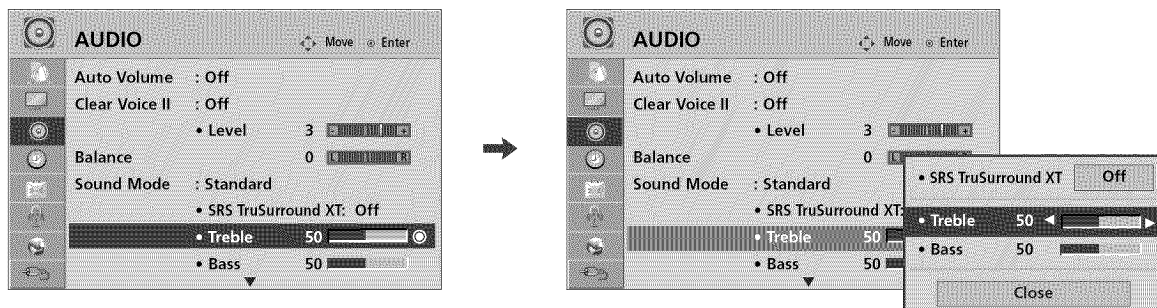



- **Standard, Music, Cinema, Sport, and Game** are preset for optimum sound quality at the factory.
- You can also adjust **Sound Mode** in the **Q.MENU**.
- **Standard:** Offers standard-quality sound.
- **Music:** Optimizes sound for listening to music.
- **Cinema:** Optimizes sound for watching movies.
- **Sport:** Optimizes sound for watching sports events.
- **Game:** Optimizes sound for playing games.

SOUND & LANGUAGE CONTROL

SOUND SETTING ADJUSTMENT - USER MODE

Adjust the sound to suit your taste and room situations.









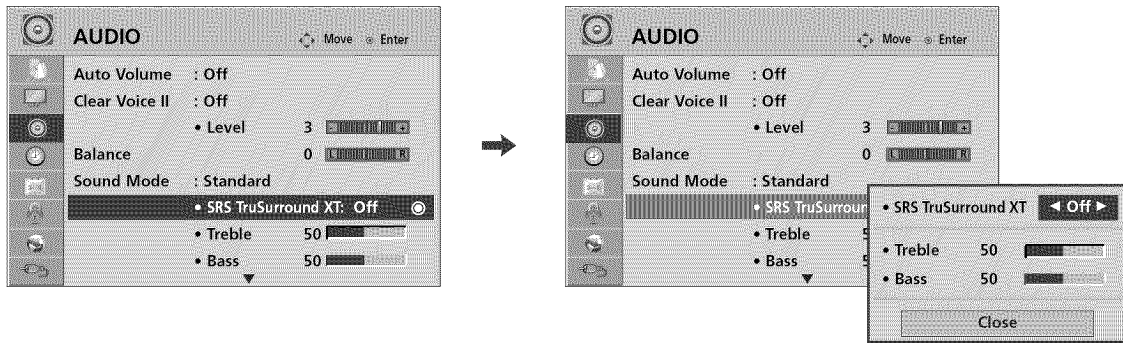

- 1   Select **AUDIO**.
- 2   Select **Sound Mode**.
- 3   Select **Standard, Music, Cinema, Sport, or Game**.
- 4   Select **Treble or Bass**.
- 5   Make appropriate adjustments.
- 6  Return to the previous menu.
-  Return to TV viewing.

SRS TRUSURROUND XT

Select this option to sound realistic.



- 1   Select **AUDIO**.
- 2   Select **SRS TruSurround XT**.
- 3   Select **On** or **Off**.
- 4  Return to the previous menu.
-  Return to TV viewing.







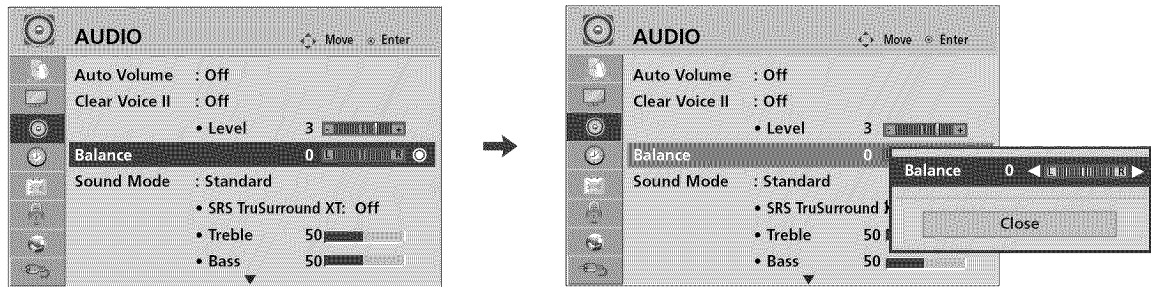

- If sound quality or volume is not at the level you want, it is recommended to use a separate home theater system or amp to cope with different user environments.
- If you select “**Clear Voice II-On**”, the **SRS TruSurround XT** feature will not operate.
- **SRS TruSurround XT**: TruSurround XT is a patented SRS technology that solves the problem of playing 5.1 multichannel content over two speakers.

SOUND & LANGUAGE CONTROL

BALANCE

Adjust the left/right sound of speaker to suit your taste and room situations.









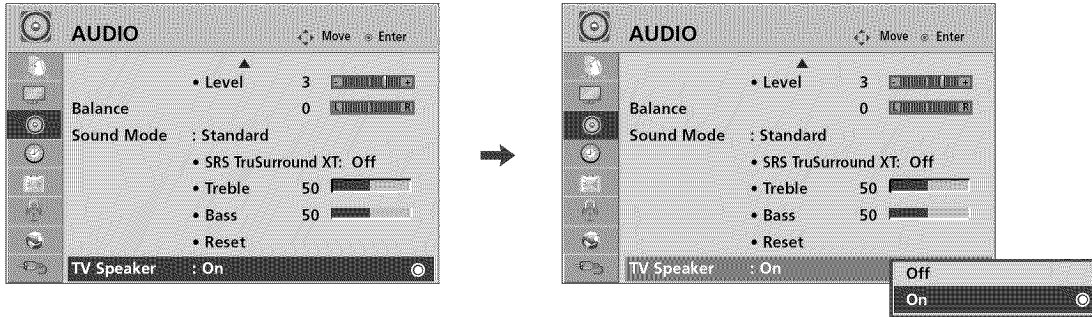

-   Select **AUDIO**.
-   Select **Balance**.
-   Make appropriate adjustments.
-  Return to the previous menu.
-  Return to TV viewing.

TV SPEAKERS ON/OFF SETUP

If you wish to use an external Hi-Fi system or a SRS System, turn off the TV's internal speakers.

In **AV**, **Component**, **RGB** and **HDMI** with HDMI to DVI cable, the TV speaker can be operational even when there is no video signal.







- 1   Select **AUDIO**.
- 2   Select **TV Speaker**.
- 3   Select **On** or **Off**.
- 4  Return to the previous menu.
-  Return to TV viewing.

SOUND & LANGUAGE CONTROL

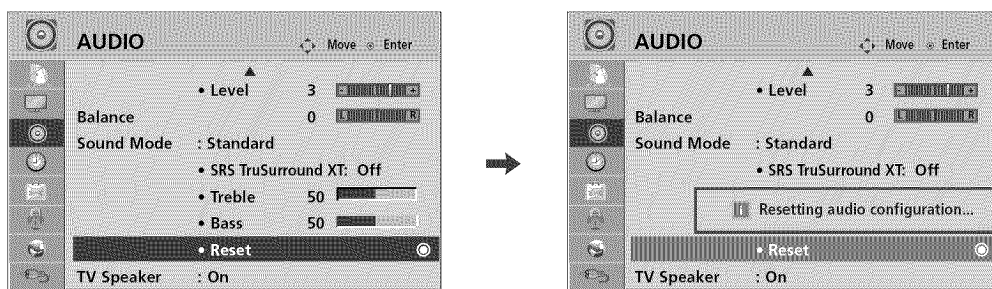
AUDIO RESET

Settings of the selected Sound Mode return to the default factory settings.

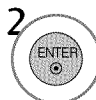
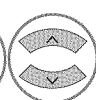

-   Select **AUDIO**.
-   Select **Reset**.
-  Initialize the adjusted value.
-  Return to TV viewing.

STEREO/SAP BROADCAST SETUP

On analog signals, this TV can receive MTS stereo programs and any SAP (Secondary Audio Program) that accompanies the stereo program if the station transmits an additional sound signal. Mono sound is automatically used if the broadcast is only in Mono.

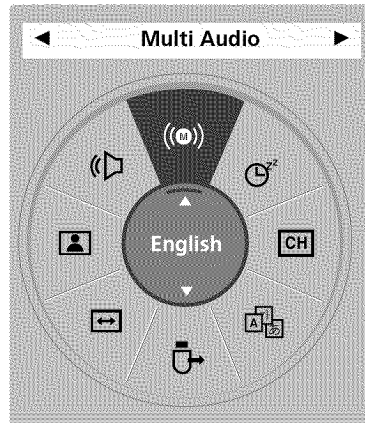

Analog TV

1   Select **SAP**.

2  Select **Mono, Stereo, or SAP**.

3  Return to TV viewing.

Digital TV

1   Select **Multi Audio**.

2  Select other languages.



3  Return to TV viewing.

SOUND & LANGUAGE CONTROL

AUDIO LANGUAGE

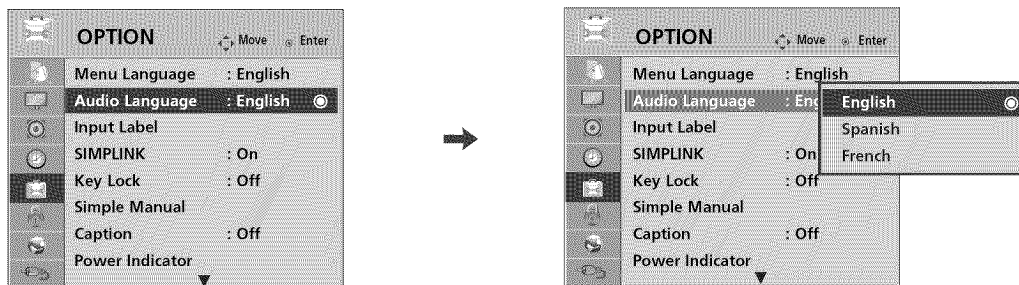
This feature operates only in DTV/CADTV mode.

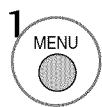

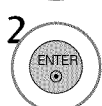
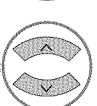
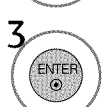
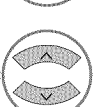
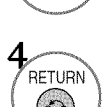
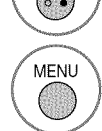





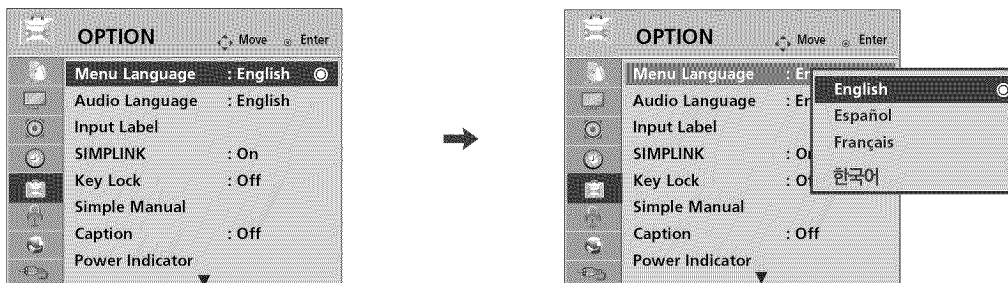

-   Select **OPTION**.
-   Select **Audio Language**.
-   Select your desired language.
-  Return to the previous menu.
-  Return to TV viewing.

ON-SCREEN MENUS LANGUAGE SELECTION

The menus can be shown on the screen in the selected language.

Changing the menu language for the TV also changes the default language for Yahoo! TV Widgets (except 한국어).



- 1   Select **OPTION**.
- 2   Select **Menu Language**.
- 3   Select your desired language.
From this point on, the on-screen menus will be shown in the selected language.
- 4  Return to the previous menu.
-  Return to TV viewing.









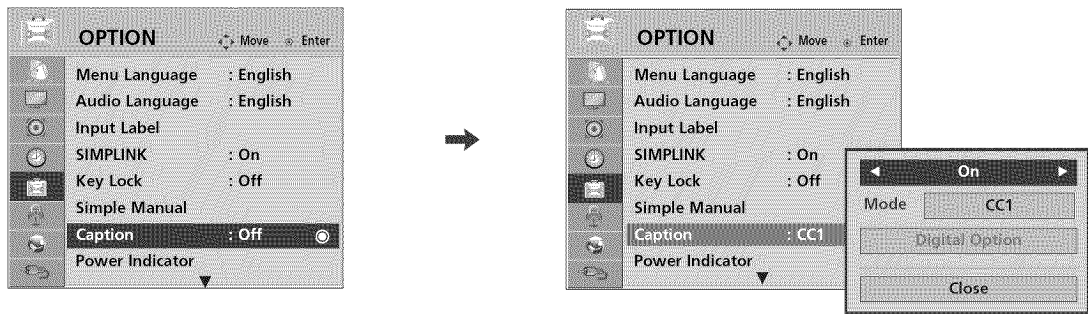

SOUND & LANGUAGE CONTROL

CAPTION MODE

Analog Broadcasting System Captions

Captions are provided to help the hearing impaired watch TV. Select a caption mode for displaying captioning information if provided on a program. Analog caption displays information at any position on the screen and is usually the program's dialog. Caption/Text, if provided by the broadcaster, would be available for both digital and analog channels on the Antenna/Cable. This TV is programmed to memorize the caption/text mode which was last set when you turned the power off. This function is only available when **Caption Mode** is set **On**.



- 1   Select **OPTION**.
- 2   Select **Caption**.
- 3   Select **On**.
- 4   Select **CC1-4** or **Text1-4**.
- 5  Return to the previous menu.
-  Return to TV viewing.

- When selecting **Off**, Sub-menus for Analog, DTV, and Digital Option become disabled.

■ CAPTION

The term for the words that scroll across the bottom of the TV screen; usually the audio portion of the program provided for the hearing impaired.

■ TEXT

The term for the words that appear in a large black frame and almost cover the entire screen; usually messages provided by the broadcaster.









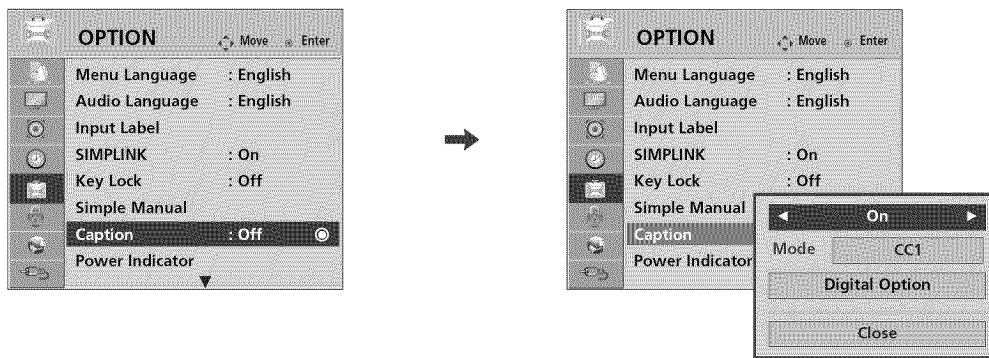

Digital Broadcasting System Captions

Choose the language you want the DTV/CADTV Captions to appear in.

Other Languages can be chosen for digital sources only if they are included on the program.

This function is only available when Caption Mode is set On.



- 1   Select **OPTION**.
- 2   Select **Caption**.
- 3   Select **On**.
- 4   Select **CC1-4, Text1-4, or Service1 - 6**.
- 5  Return to the previous menu.
-  Return to TV viewing.

SOUND & LANGUAGE CONTROL

Caption Option

Customize the DTV/CADTV captions that appear on your screen.

This function is only available when **Caption Mode** is set **On**.

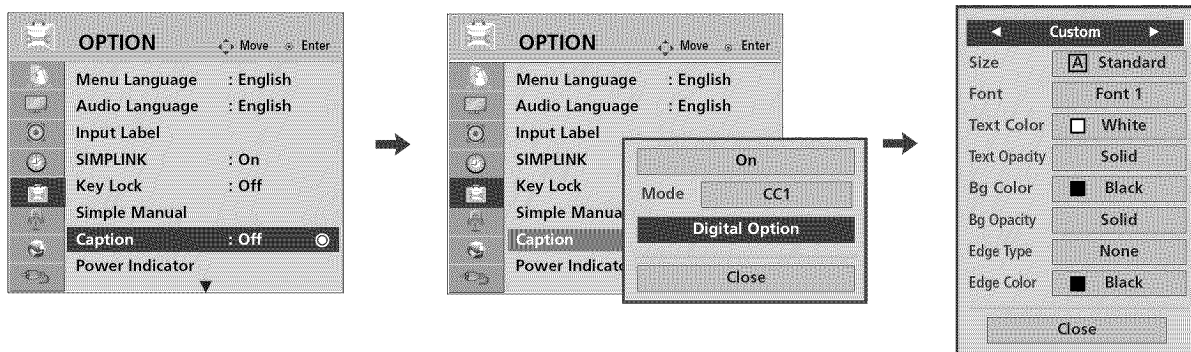



1   Select **OPTION**.

2   Select **Caption**

3   Select **On**.

4   Select **Digital Option**.

5   Select **Custom**.

6   Customize the **Size**, **Font**, etc., to your preference. A preview icon is provided at the bottom of the screen, use it to see the caption language.

7  Return to the previous menu.

 Return to TV viewing.

- **Size:** Set the word size.
- **Font:** Select a typeface for the text.
- **Text Color:** Choose a color for the text.
- **Text Opacity:** Specify the opacity for the text color.
- **Bg (Background) Color:** Select a background color.
- **Bg (Background) Opacity:** Select the opacity for the background color.
- **Edge Type:** Select an edge type.
- **Edge Color:** Select a color for the edges.

TIME SETTING

CLOCK SETTING









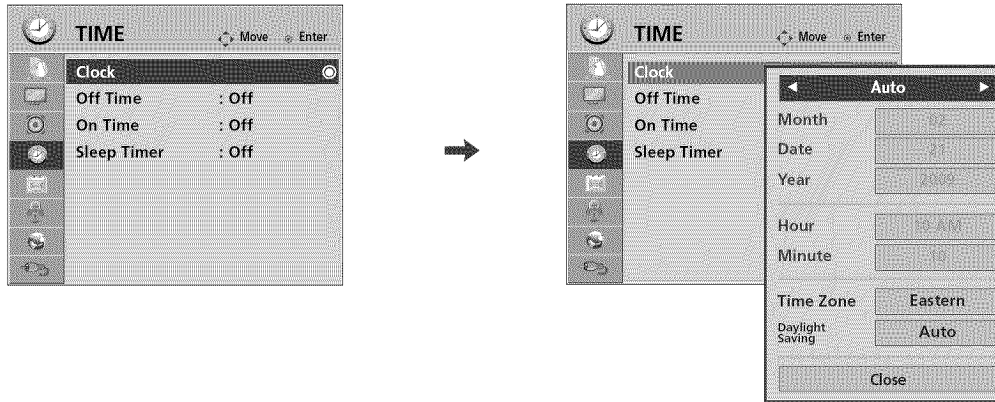



Auto Clock Setup

The time is set automatically from a digital channel signal.

The digital channel signal includes information for the current time provided by the broadcasting station.

Set the clock manually if the current time is set incorrectly by the auto clock function.



- 1   Select **TIME**.
- 2   Select **Clock**.
- 3   Select **Auto**.
- 4   Select your viewing area time zone.
: **Eastern, Central, Mountain, Pacific, Alaska, or Hawaii.**
- 5   Select **Auto, Off, or On** (depending on whether or not your viewing area observes Daylight Saving time).
- 6  Return to the previous menu.
-  Return to TV viewing.



TIME SETTING

Manual Clock Setup

If the current time setting is wrong, reset the clock manually.

If you remove power from the TV or turn off the main power switch on the TV, the **Clock** will be reset.

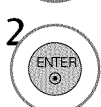
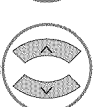
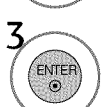
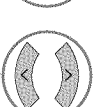
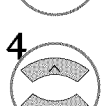
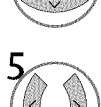
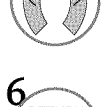
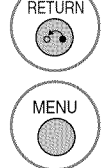

-   Select **TIME**.
-   Select **Clock**.
-   Select **Manual**.
-  Select the Year, Month, Date, Hour, or Minutes option.
-  Set the Year, Month, Date, Hour, or Minutes option.
-  Return to the previous menu.
-  Return to TV viewing.

AUTO ON/OFF TIME SETTING

This function operates only if the current time has been set.

The **Off Time** function overrides the **On Time** function if they are both set to the same time.

The TV must be in standby mode for the **On Time** to work.

If you do not press any button within 2 hours after the TV turns on with the **On Time** function, the TV will automatically revert to standby mode.

If you turn the TV off using the main power switch after setting **On Time**, the **On Time** function will not work because the main power is off.

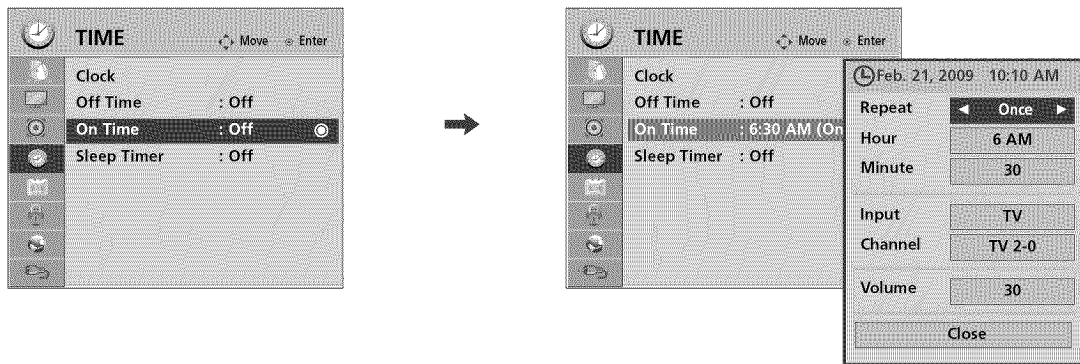

- 1 Select **TIME**.
- 2 Select **Off Time** or **On Time**.
- 3 Select **Repeat**.
- 4 Select **Off, Once, Daily, Mon.~Fri., Mon.~Sat., Sat.~ Sun., or Sun..**
- 5 Select and set **Hour** or **Minute**.
- 6 Return to the previous menu.
- Return to TV viewing.





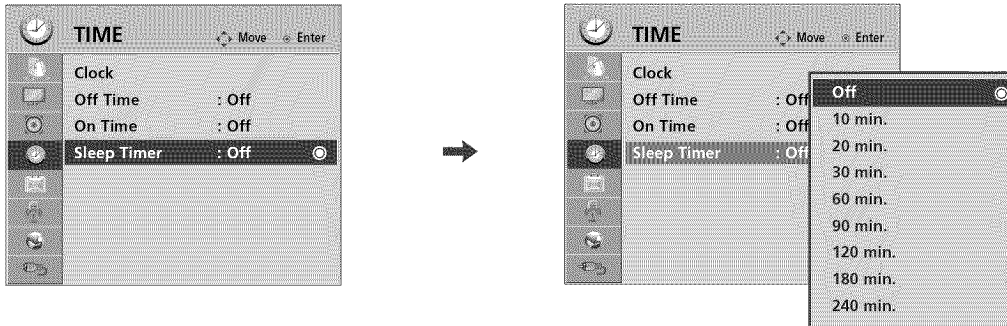

- To cancel **On/Off Time** function, select **Off**.
 - Only for **On Time** function
- 1 Select **Input**.
 - 2 Select the desired input source.
 - 3 When Selecting **TV**: set the channel at turn-on.
 - 4 Adjust to sound level at turn-on.

TIME SETTING

SLEEP TIMER SETTING

The Sleep Timer turns the TV off at the preset time.
Note that this setting is cleared when the TV is turned off.

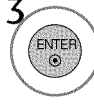
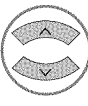

- 1   Select **TIME**.
- 2   Select **Sleep Timer**.
- 3   Make appropriate adjustments.
- 4  Return to the previous menu.
-  Return to TV viewing.

- To cancel the **Sleep Timer**, select **Off**.
- You can also adjust **Sleep Timer** in the **Q.MENU**.

PARENTAL CONTROL / RATINGS

Parental Control can be used to block specific channels, ratings and other viewing sources. This setting also affect Netflix movie.

The Parental Control Function (V-Chip) is used to block program viewing based on the ratings sent by the broadcasting station. The default setting is to allow all programs to be viewed. Viewing can be blocked by choosing the type of the program and the categories. It is also possible to block all program viewing for a time period. To use this function, the following must be done :

1. Set ratings and categories to be blocked.
2. Specify a password
3. Enable the lock

V-Chip rating and categories

Rating guidelines are provided by broadcasting stations. Most television programs and television movies can be blocked by TV Rating and/or Individual Categories. Movies that have been shown at the theaters or direct-to-video movies use the Movie Rating System (MPAA) only.

Ratings for Television programs including made-for-TV movies:





- TV-G (General audience)
- TV-PG (Parental guidance suggested)
- TV-14 (Parents strongly cautioned)
- TV-MA (Mature audience only)
- TV-Y (All children)
- TV-Y7 (Children 7 years older)

SET PASSWORD & LOCK SYSTEM

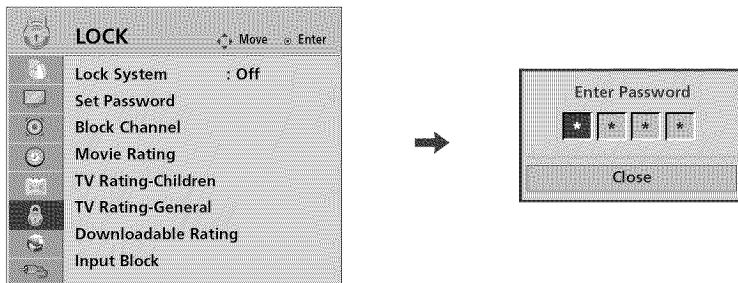
Setting up Your Password

Set up blocking schemes to block specific channels, ratings, and external viewing sources. A password is required to gain access to this menu.



1.    Select **LOCK**.
2.  Input the password.



■ Enter the password as requested.
■ The TV is set up with the initial password "0-0-0-0".

PARENTAL CONTROL / RATINGS

Lock System

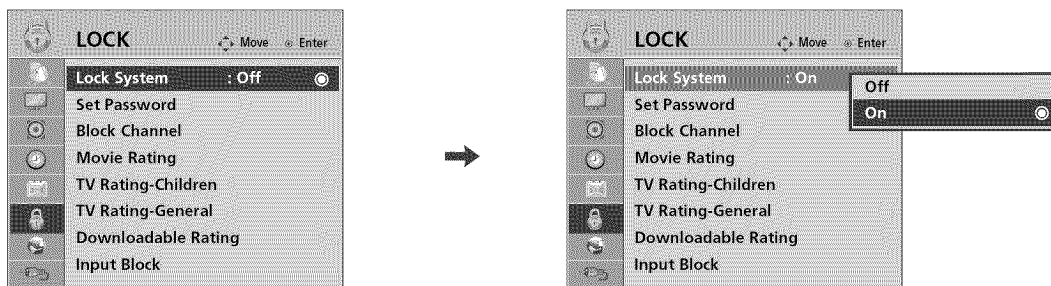
Enables or disables the blocking scheme you set up previously.

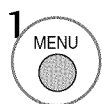

1 MENU    Select LOCK.

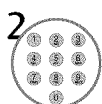
2  Input the password.

3  Select Lock System.

4   Select On or Off.

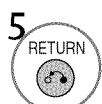
5  Return to the previous menu.

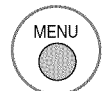

 Return to TV viewing.

■ When you select **On**, the Lock System is enable.

Set Password

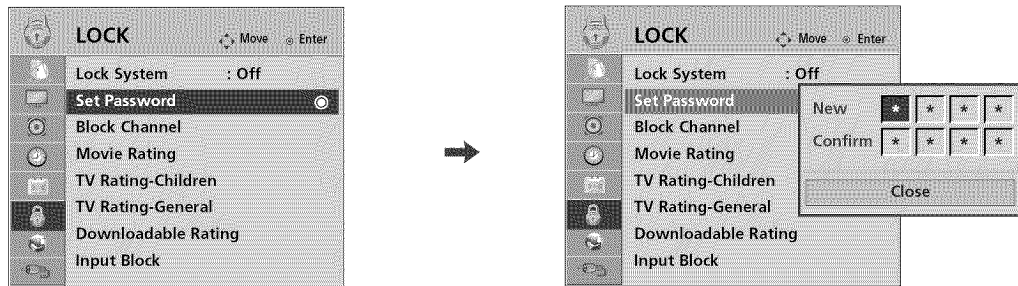

Change the password by inputting a new password twice.





1    Select **LOCK**.

2  Input the password.

3  Select **Set Password**.

4   Choose any 4 digits for your new password.
As soon as the 4 digits are entered, re-enter the same 4 digits on the **Confirm**.

5  Return to the previous menu.

 Return to TV viewing.

PARENTAL CONTROL / RATINGS

CHANNEL BLOCKING

Blocks any channels that you do not want to watch or that you do not want your children to watch.

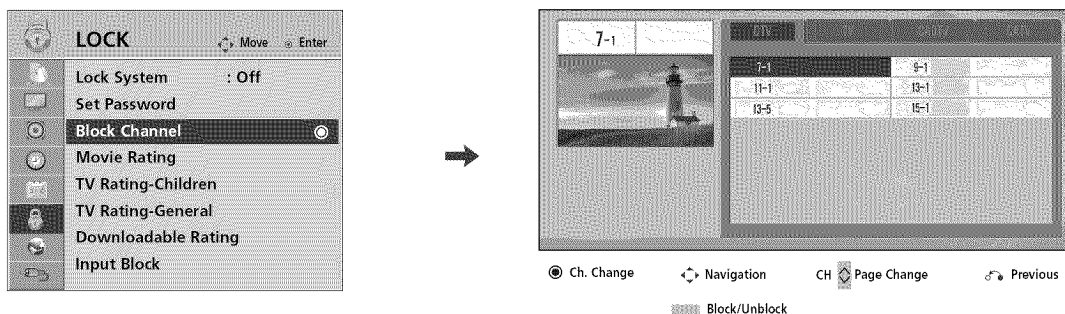

1 Select **LOCK**.

2 Input the password.

3 Select **Block Channel**.

4 Select a channel to block or unblock.

5 Block or unblock a channel.

6 Return to the previous menu.

Return to TV viewing.







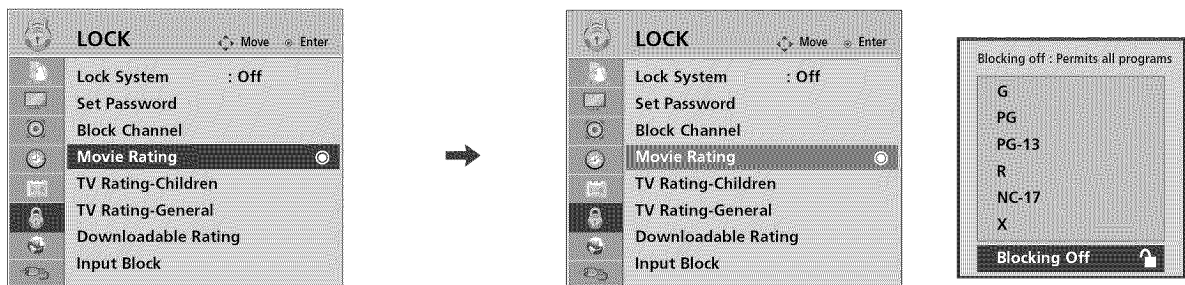

■ If a channel is locked, enter the password to unlock it temporarily.

MOVIE & TV RATING

Movie Rating (MPAA)

Blocks movies according to the movie ratings limits specified, so children cannot view certain movies. You can set the ratings limit by blocking out all the movies with the ratings above a specified level. Keep in mind that the movie ratings limit only applies to movies shown on TV, not TV programs, such as soap operas.



-    Select **LOCK**.
-  Input the password.
-  Select **Movie Rating**.
-   Select **G, PG, PG-13, R, NC-17, X, or Blocking Off**.
-  Return to the previous menu.
-  Return to TV viewing.



- If **Movie Rating, TV Rating-Children** or **TV Rating-General** is locked, enter the password to unlock it temporarily.
- **G** (General audience)
- **PG** (Parental guidance suggested)
- **PG-13** (Parents strongly cautioned)
- **R** (Restricted)
- **NC-17** (No one 17 and under admitted)
- **X** (Adult only)
- **Blocking Off** (Permits all programs)
- ▶ If you set **PG-13**: **G** and **PG** movies will be available, **PG-13, R, NC-17** and **X** will be blocked.

PARENTAL CONTROL / RATINGS

TV Rating Children

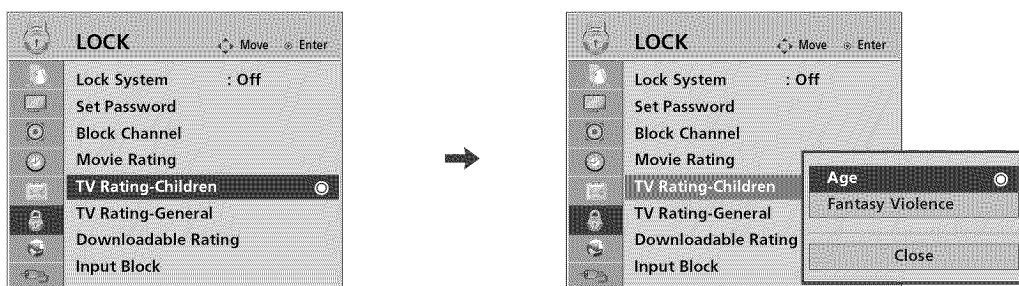
Prevents children from watching certain children's TV programs, according to the ratings limit set. The children rating does not apply to other TV programs. Unless you block certain TV programs intended for mature audiences in the TV Rating - sub menu, your children can view those programs.

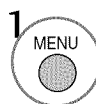

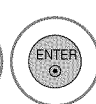
1    Select LOCK.

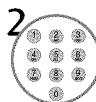
2  Input the password.

3  Select TV Rating-Children.

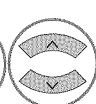
4   Select Age or Fantasy Violence.

5   Select block options.

6  Return to the previous menu.



 Return to TV viewing.

- Age (applies to TV-Y, TV-Y7)
- Fantasy Violence (applies to TV-Y7)

TV Rating General

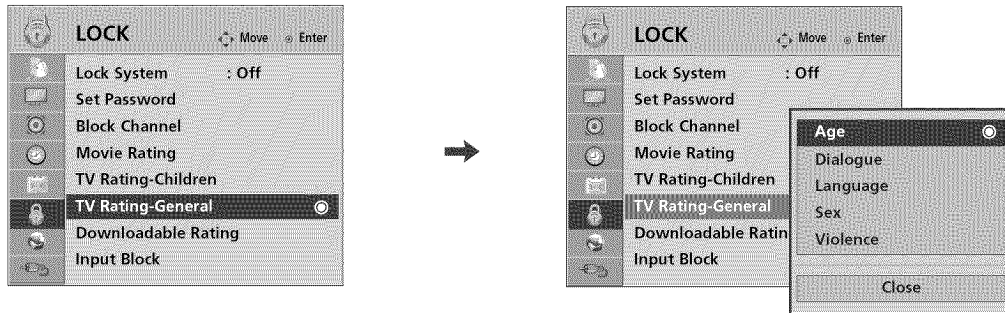

Based on the ratings, blocks certain TV programs that you and your family do not want to view.



1    Select **LOCK**.

2  Input the password.

3  Select **TV Rating-General**.

4   Select **Age, Dialogue, Language, Sex or Violence**.

5   Select block options.

6  Return to the previous menu.

 Return to TV viewing.

- Age (applies to TV-G,TV-PG,TV-14,TV-MA).
- Dialogue-sexual dialogue (applies to TV-PG,TV-14).
- Language-adult language (applies to TV-PG, TV-14, TV-MA).
- Sex-sexual situations (applies to TV-PG, TV-14, TV-MA).
- Violence (applies to TV-PG, TV-14, TV-MA).

PARENTAL CONTROL / RATINGS



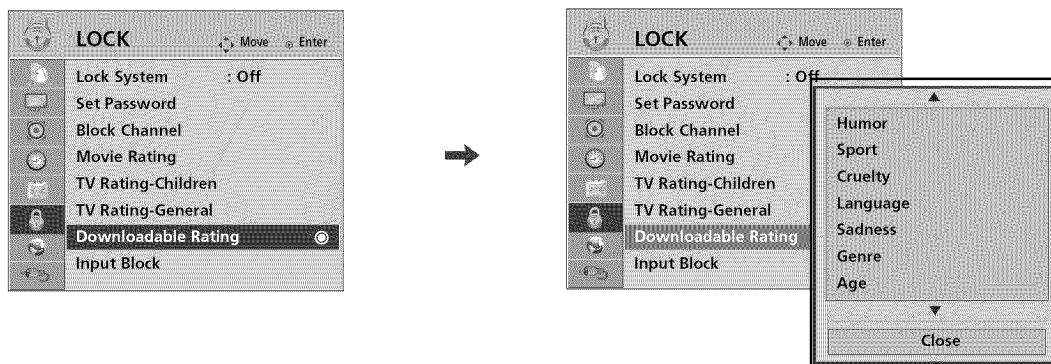

DOWNLOADABLE RATING

This function is available only for digital channels.

This function operates only when TV has received Region5 Rating data.

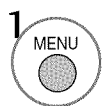

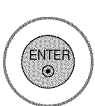
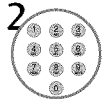
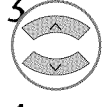
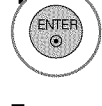
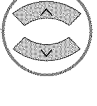
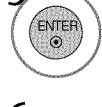
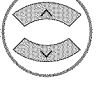
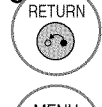
■ Based on rating table, your TV's OSD (On Screen Display) may differ slightly from what is shown in this manual.









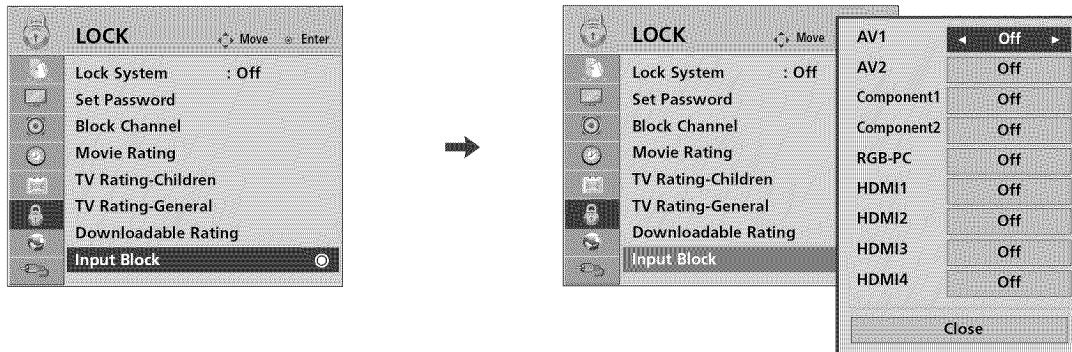

-    Select **LOCK**.
-  Input the password.
-  Select **Downloadable Rating**.
-   Select desired **Downloadable Rating** option.
-   Select desired option and block it.
-  Return to the previous menu.
-  Return to TV viewing.

■ If a Downloadable rating is locked, enter the password to unlock it temporarily.

EXTERNAL INPUT BLOCKING

Enables you to block an input.



-    Select **LOCK**.
-  Input the password.
-  Select **Input Block**.
-   Select input source.
-  Select **On** or **Off**.
-  Return to the previous menu.
-  Return to TV viewing.

APPENDIX

TROUBLESHOOTING

Abnormal Operation	
The remote control doesn't work	<ul style="list-style-type: none">■ Check to see if there is any object between the product and the remote control causing obstruction. Ensure you are pointing the remote control directly at the TV.■ Ensure that the batteries are installed with correct polarity (+ to +, - to -).■ Ensure that the correct remote operating mode is set: TV, VCR etc.■ Install new batteries. <p style="text-align: right;">*This feature is not available for all models.</p>
Power is suddenly turned off	<ul style="list-style-type: none">■ Is the sleep timer set?■ Check the power control settings. Power interrupted.■ If there is no signal, the TV turns off automatically in 15 minutes.

Video Problems	
No picture & No sound	<ul style="list-style-type: none">■ Check whether the product is turned on.■ Try another channel. The problem may be with the broadcast.■ Is the power cord inserted into wall power outlet?■ Check your antenna direction and/or location.■ Test the wall power outlet, plug another product's power cord into the outlet where the product's power cord was plugged in.
Picture appears slowly after switching on	<ul style="list-style-type: none">■ This is normal, the image is muted during the product startup process. Please contact your service center, if the picture has not appeared after five minutes.
No or poor color or poor picture	<ul style="list-style-type: none">■ Adjust Color in menu option.■ Keep a sufficient distance between the product and the VCR.■ Try another channel. The problem may be with the broadcast.■ Are the video cables installed properly?■ Activate any function to restore the brightness of the picture.
Horizontal/vertical bars or picture shaking	<ul style="list-style-type: none">■ Check for local interference such as an electrical appliance or power tool.
Poor reception on some channels	<ul style="list-style-type: none">■ Station or cable product experiencing problems, tune to another station.■ Station signal is weak, reorient antenna to receive weaker station.■ Check for sources of possible interference.
Lines or streaks in pictures	<ul style="list-style-type: none">■ Check antenna (Change the direction of the antenna).
No picture when connecting HDMI	<ul style="list-style-type: none">■ Check HDMI cable over version 1.3. The HDMI cables don't support HDMI version 1.3, it cause flickers or no screen display. In this case use the latest cables that support HDMI version 1.3.

Audio Problems

Picture OK & No sound	<ul style="list-style-type: none">■ Press the VOL or VOLUME button.■ Sound muted? Press MUTE button.■ Try another channel. The problem may be with the broadcast.■ Are the audio cables installed properly?
No output from one of the speakers	<ul style="list-style-type: none">■ Adjust Balance in menu option.
Unusual sound from inside the product	<ul style="list-style-type: none">■ A change in ambient humidity or temperature may result in an unusual noise when the product is turned on or off and does not indicate a fault with the product.
No sound when connecting HDMI/USB	<ul style="list-style-type: none">■ Check HDMI cable over version 1.3.■ Check USB cable over version 2.0.■ Use normal MP3 file. <p style="text-align: right;">*This feature is not available for all models.</p>

PC Mode Problems

The signal is out of range	<ul style="list-style-type: none">■ Adjust resolution, horizontal frequency, or vertical frequency on the PC.■ Check the input source.
Vertical bar or stripe on background & Horizontal Noise & Incorrect position	<ul style="list-style-type: none">■ Activate the Auto configure feature or adjust size, phase, or H/V position. (Option)
Screen color is unstable or single color	<ul style="list-style-type: none">■ Check the signal cable.■ Reinstall the PC video card.
When connecting the HDMI cable to the PC, there is no audio.	<ul style="list-style-type: none">■ Check the manual for the video card in the PC to see if it supports HDMI audio and how to set it up properly.

Yahoo! TV Widgets Problems		
Failed to launch Yahoo! TV Widgets	Was the customer watching HDMI input?	<ul style="list-style-type: none"> ■ If customer uses HDMI with Simplink is ON, then WIDGETS button blocked. ■ To use Yahoo! TV Widget watching HDMI input, turn off “Simplink-on” in the OPTION menu. Or change other Input and press the WIDGETS button.
	Was the customer watching My Media?	<ul style="list-style-type: none"> ■ If customer uses MY MEDIA, then WIDGETS button blocked. ■ Exit MY MEDIA by pressing the NETCAST button and select Yahoo!
	Did the customer see “Starting Yahoo! TV Widgets” remain and TV Widget not displayed?	<ul style="list-style-type: none"> ■ Press the NETCAST button and then select NETFLIX, press the WIDGETS button to enter Yahoo! TV Widget. This re-starts Yahoo! TV Widgets.
	Nothing happens when pressing WIDGETS button	<ul style="list-style-type: none"> ■ Press WIDGETS button and wait a minute, then nothing happens. ■ Contact Yahoo! help site: http://connectedtv.yahoo.com/help ■ Turn off TV and Turn on TV, press NETCAST button and then BLUE button, select “Restore Yahoo! Factory Settings” to restore Yahoo! Factory Settings.
Failed to open some widgets	Is “Loading” message displayed?	<ul style="list-style-type: none"> ■ If yes, try after “Loading” message disappeared. ■ If “Loading” message does not disappeared, then delete that widget and re-install it.
	Check IP Address setting is OK?	<ul style="list-style-type: none"> ■ If not, connect Network Cable properly and set IP address from menu and try again.
	Is Connection Unavailable icon (yellow triangle) displayed on snippet?	<ul style="list-style-type: none"> ■ If connection unavailable icon displayed, try later because some server which widget uses may are under maintenance. If this happens again, contact proper help site displayed on setting panel for each widget or contact Yahoo! help site. http://connectedtv.yahoo.com/help
	The customer cannot open a widget but all other widget working properly – for example, weather forecast on Weather widget or stock price/fluctuation for finance widget and so on.	<ul style="list-style-type: none"> ■ Try again later or If the problem still happens, ■ Delete that widget with following instruction. Press Yellow button from Dock, and then press RED button twice to delete that widget. After deleted, open Widget Gallery and browse to find that widget and select “Add Widget to My Profile” to install that widget and then try again. ■ If problem still happens, restore Yahoo! Factory Setting by pressing NETCAST button and BLUE button on your remote control.
Misc-Caption, Language displayed within Widget	Did the customer change Menu language but Widget did not change its language.	<ul style="list-style-type: none"> ■ Some Widget does not fully support as much as TV Menu. ■ The help site for individual widget can be found settings panel of each widget by pressing GREEN button on your remote after open that widget from the Dock.

Yahoo! TV Widgets Problems

Widget is stuck if the remote control button is pressed.	Press RETURN button and try again later.	<ul style="list-style-type: none"> ■ Normal operation for return previous status of Yahoo! TV Widgets. Some server response is not fast as you expect.
	Check IP Address setting is OK?	<ul style="list-style-type: none"> ■ If not, connect Network Cable properly and set IP address from Network menu and try again or contact Internet service provider.
	Press RED or WIDGETS button on remote control.	<ul style="list-style-type: none"> ■ Exits Yahoo! TV Widgets by pressing RED button on your remote and re-enter by WIDGETS button.
	Press NETCAST button.	<ul style="list-style-type: none"> ■ Exits Yahoo! TV Widgets by pressing NETCAST button and enter NETFLIX temporarily, and re-enter Yahoo! Widgets by pressing NETCAST button and select Yahoo! ■ If problem still happens for one widget. ■ Delete that widget with following instruction. Press Yellow button from Dock, and then press RED button twice to delete that widget. After deleted, open Widget Gallery and browse to find that widget and select "Add Widget to My Profile" to install that widget and then try again. ■ If problem still happens for all widgets, restore Yahoo! Factory Setting by pressing NETCAST button and BLUE button on your remote control, and select "Restore Yahoo! Factory Settings" item on your TV Screen.
Gallery - Unable to install widget from gallery	Check IP Address setting is OK?	<ul style="list-style-type: none"> ■ If not, connect Network Cable properly and set IP address from menu-Option and try again or contact Internet service provider.
	Is Lock Icon on right side of "Add Widget to My Profile"?	<ul style="list-style-type: none"> ■ Need Owner PIN to install. If you forgot Owner PIN, contact Yahoo! for further help. http://connectedtv.yahoo.com/help
	"Install completed" but it never work.	<ul style="list-style-type: none"> ■ Try to re-start Yahoo! TV Widgets after enter MY MEDIA and exit from MY MEDIA. ■ Or Delete it and re-install it.
Flickr - "We could not find anything to display" message displayed	Is connection unavailable icon (yellow triangle) displayed?	<ul style="list-style-type: none"> ■ If yes, check network settings or contact internet service provider, or try later.
	Did you sign-in Yahoo! account?	<ul style="list-style-type: none"> ■ If yes, you need to upload your photos to Flickr site to display when sign-in Yahoo. ■ If not, try again later. The Flickr server may be under maintenance, or contact service provider.

APPENDIX

MAINTENANCE

Early malfunctions can be prevented. Careful and regular cleaning can extend the amount of time you can enjoy your new TV.

Caution: Be sure to turn the power off and unplug the power cord before you begin any cleaning.

Cleaning the Screen

- 1 Here's a great way to keep the dust off your screen for a while. Wet a soft cloth in a mixture of lukewarm water and a little fabric softener or dish washing detergent. Wring the cloth until it's almost dry, and then use it to wipe the screen.
- 2 Make sure the excess water is off the screen, and then let it air-dry before you turn on your TV.

Cleaning the Cabinet

- To remove dirt or dust, wipe the cabinet with a soft, dry, lint-free cloth.
- Please be sure not to use a wet cloth.

Extended Absence

CAUTION

- ▶ If you expect to leave your TV dormant for a long time (such as a vacation), it's a good idea to unplug the power cord to protect against possible damage from lightning or power surges.

PRODUCT SPECIFICATIONS

MODELS		50PS80 (50PS80-UA)	60PS80 (60PS80-UA)	
Dimensions (Width x Height x Depth)	With stand	48.3 x 32.9 x 14.3 inches 1228.0 x 836.5 x 364.0 mm	57.7 x 38.6 x 15.5 inches 1465.4 x 982.6 x 395.5 mm	
	Without stand	48.3 x 31.3 x 3.1 inches 1228.0 x 795.1 x 78.9 mm	57.7 x 36.5 x 3.2 inches 1465.4 x 926.7 x 82.1 mm	
Weight	With stand	82.2 lbs / 37.3 kg	115.5 lbs / 52.4 kg	
	Without stand	75.6 lbs / 34.3 kg	102.7 lbs / 46.6 kg	
MODELS		42LH50 (42LH50-UC)	47LH50 (47LH50-UC)	55LH50 (55LH50-UC)
Dimensions (Width x Height x Depth)	With stand	41.4 x 28.3 x 11.6 inches 1052.2 x 719.1 x 296.2 mm	46.1 x 31.0 x 13.2 inches 1173.4 x 789.7 x 337.4 mm	53.4 x 35.4 x 16.6 inches 1357.0 x 901.0 x 423.0 mm
	Without stand	41.5 x 25.8 x 3.5 inches 1052.2 x 657.3 x 90.8 mm	46.1 x 28.4 x 3.9 inches 1173.4 x 723.4 x 100.8 mm	53.4 x 32.8 x 4.3 inches 1357.0 x 835.4 x 109.6 mm
Weight	With stand	41.8 lbs / 19.0 kg	51.5 lbs / 23.4 kg	80.2 lbs / 36.4 kg
	Without stand	37.9 lbs / 17.2 kg	45.8 lbs / 20.8 kg	72.5 lbs / 32.9 kg
Power requirement	Television System	AC100-240V ~ 50/60Hz		
Program Coverage	External Antenna Impedance	NTSC-M, ATSC, 64 & 256 QAM		
		VHF 2-13, UHF 14-69, CATV 1-135, DTV 2-69, CADTV 1-135		
		75 ohm		
Environment condition	Operating Temperature	32 ~ 104°F (0 ~ 40°C)		
	Operating Humidity	Less than 80%		
	Storage Temperature	-4 ~ 140°F (-20 ~ 60°C)		
	Storage Humidity	Less than 85%		

■ The specifications shown above may be changed without prior notice for quality improvement.

IR CODES

1. How to Connect

- Connect your wired remote control to the Remote Control port on the TV.

2. Remote Control IR Codes

Output waveform

Single pulse, modulated with 37.917KHz signal at 455KHz

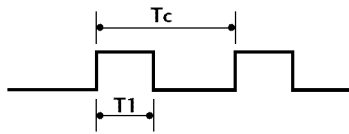

Carrier frequency
 $FCAR = 1/TC = fOSC/12$
 Duty ratio = $T1/TC = 1/3$

Configuration of frame

1st frame

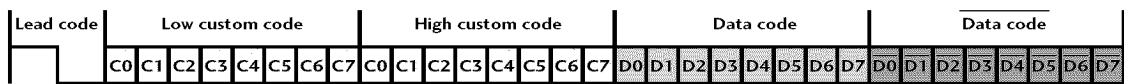

Repeat frame

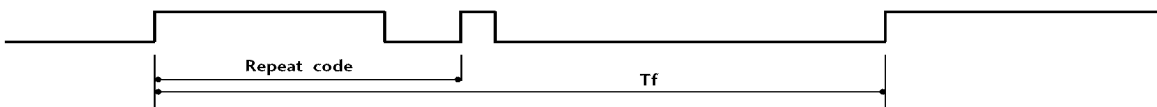

Lead code

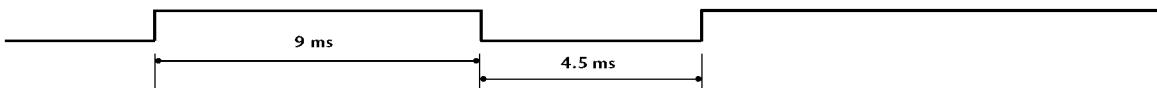

Repeat code

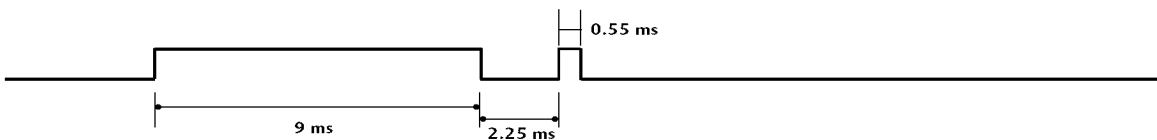

Bit description

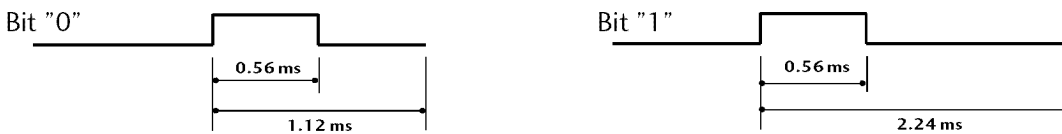

Frame interval: Tf

The waveform is transmitted as long as a key is depressed.



Code (Hexa)	Function	Note	Code (Hexa)	Function	Note
08	POWER	Remote control Button (Power On/Off)	D6	TV	Discrete IR Code (TV Input Selection)
45	Q.MENU	Remote control Button	C4	POWER ON	Discrete IR Code (Only Power On)
43	MENU	Remote control Button	C5	POWER OFF	Discrete IR Code (Only Power Off)
0B	INPUT	Remote control Button	5A	AV1	Discrete IR Code (AV1 Input Selection)
10-19	Number Key 0-9	Remote control Button	D0	AV2	Discrete IR Code (AV2 Input Selection)
4C	- (Dash)/LIST	Remote control Button	BF	COMPONENT1	Discrete IR Code (Component1 Input Selection)
1A	FLASHBK	Remote control Button	D4	COMPONENT2	Discrete IR Code (Component2 Input Selection)
09	MUTE/DELETE	Remote control Button	D5	RGB-PC	Discrete IR Code (RGB-PC Input Selection)
02	VOL +	Remote control Button	CE	HDMI1	Discrete IR Code (HDMI1 Input Selection)
03	VOL -	Remote control Button	CC	HDMI2	Discrete IR Code (HDMI2 Input Selection)
00	CH ^	Remote control Button	E9	HDMI3	Discrete IR Code (HDMI3 Input Selection)
01	CH v	Remote control Button	DA	HDMI4	Discrete IR Code (HDMI4 Input Selection)
1E	FAV/MARK/ CHAR/NUM	Remote control Button	76	Ratio 4:3	Discrete IR Code (Only 4:3 Mode)
40	^	Remote control Button	77	Ratio 16:9	Discrete IR Code (Only 16:9 Mode)
41	v	Remote control Button	AF	Ratio Zoom	Discrete IR Code (Only Zoom Mode)
07	<	Remote control Button			
06	>	Remote control Button			
44	ENTER	Remote control Button			
28	RETURN	Remote control Button			
79	RATIO	Remote control Button			
65	FREEZE	Remote control Button			
95	ENERGY SAVING	Remote control Button			
7E	SIMPLINK	Remote control Button			
AA	INFO	Remote control Button			
30	AV MODE	Remote control Button			
58	WIDGETS	Remote control Button			
59	NETCAST	Remote control Button			
72	RED	Remote control Button			
71	GREEN	Remote control Button			
63	YELLOW	Remote control Button			
61	BLUE	Remote control Button			
B1	■	Remote control Button			
B0	▶	Remote control Button			
BA		Remote control Button			
8F	◀◀	Remote control Button			
8E	▶▶	Remote control Button			

For Plasma TV

OPEN SOURCE LICENSE

GNU GENERAL PUBLIC LICENSE

Version 2, June 1991

Copyright (C) 1989, 1991 Free Software Foundation, Inc., 51 Franklin Street, Fifth Floor, Boston, MA 02110-1301 USA

Everyone is permitted to copy and distribute verbatim copies of this license document, but changing it is not allowed.

Preamble

The licenses for most software are designed to take away your freedom to share and change it. By contrast, the GNU General Public License is intended to guarantee your freedom to share and change free software - to make sure the software is free for all its users. This General Public License applies to most of the Free Software Foundation's software and to any other program whose authors commit to using it. (Some other free software foundation software is covered by the GNU Lesser General Public License instead.) You can apply it to your programs, too.

When we speak of free software, we are referring to freedom, not price. Our General Public Licenses are designed to make sure that you have the freedom to distribute copies of free software (and charge for this service if you wish), that you receive source code or can get it if you want it, that you can change the software or use pieces of it in new free programs; and that you know you can do these things.

To protect your rights, we need to make restrictions that forbid anyone to deny you these rights or to ask you to surrender the rights. These restrictions translate to certain responsibilities for you if you distribute copies of the software, or if you modify it.

For example, if you distribute copies of such a program, whether gratis or for a fee, you must give the recipients all the rights that you have. You must make sure that they, too, receive or can get the source code. And you must show them these terms so they know their rights.

We protect your rights with two steps: (1) copyright the software, and (2) offer you this license which gives you legal permission to copy, distribute and/or modify the software.

Also, for each author's protection and ours, we want to make certain that everyone understands that there is no warranty for this free software. If the software is modified by someone else and passed on, we want its recipients to know that what they have is not the original, so that any problems introduced by others will not reflect on the original authors' reputations.

Finally, any free program is threatened constantly by software patents. We wish to avoid the danger that redistributors of a free program will individually obtain patent licenses, in effect making

the program proprietary. To prevent this, we have made it clear that any patent must be licensed for everyone's free use or not licensed at all.

The precise terms and conditions for copying, distribution and modification follow.

GNU GENERAL PUBLIC LICENSE

TERMS AND CONDITIONS FOR COPYING, DISTRIBUTION AND MODIFICATION

0. This license applies to any program or other work which contains a notice placed by the copyright holder saying it may be distributed under the terms of this General Public License. The "Program", below, refers to any such program or work, and a "work based on the Program" means either the Program or any derivative work under copyright law: that is to say, a work containing the Program or a portion of it, either verbatim or with modifications and/or translated into another language. (Hereinafter, translation is included without limitation in the term "modification".) Each licensee is addressed as "you".

Activities other than copying, distribution and modification are not covered by this license; they are outside its scope. The act of running the Program is not restricted, and the output from the program is covered only if its contents constitute a work based on the program (independent of having been made by running the program). Whether that is true depends on what the program does.

1. You may copy and distribute verbatim copies of the program's source code as you receive it, in any medium, provided that you conspicuously and appropriately publish on each copy an appropriate copyright notice and disclaimer of warranty; keep intact all the notices that refer to this license and to the absence of any warranty; and give any other recipients of the program a copy of this license along with the Program.

You may charge a fee for the physical act of transferring a copy, and you may at your option offer warranty protection in exchange for a fee.

2. You may modify your copy or copies of the program or any portion of it, thus forming a work based on the Program, and copy and distribute such modifications or work under the terms of section 1 above, provided that you also meet all of these conditions:

a) You must cause the modified files to carry prominent notices stating that you changed the files and the date of any change.

- b) You must cause any work that you distribute or publish, that in whole or in part contains or is derived from the Program or any part thereof, to be licensed as a whole at no charge to all third parties under the terms of this license.
- c) If the modified program normally reads commands interactively when run, you must cause it, when started running for such interactive use in the most ordinary way, to print or display an announcement including an appropriate copyright notice and a notice that there is no warranty (or else, saying that you provide a warranty) and that users may redistribute the program under these conditions, and telling the user how to view a copy of this license. (Exception: if the Program itself is interactive but does not normally print such an announcement, your work based on the Program is not required to print an announcement.)

These requirements apply to the modified work as a whole. If identifiable sections of that work are not derived from the Program, and can be reasonably considered independent and separate works in themselves, then this license, and its terms, do not apply to those sections when you distribute them as separate works. But when you distribute the same sections as part of a whole which is a work based on the Program, the distribution of the whole must be on the terms of this license, whose permissions for other licensees extend to the entire whole, and thus to each and every part regardless of who wrote it.

Thus, it is not the intent of this section to claim rights or contest your rights to work written entirely by you; rather, the intent is to exercise the right to control the distribution of derivative or collective works based on the program.

In addition, mere aggregation of another work not based on the program with the Program (or with a work based on the program) on a volume of a storage or distribution medium does not bring the other work under the scope of this license.

- 3. You may copy and distribute the program (or a work based on it, under section 2) in object code or executable form under the terms of sections 1 and 2 above provided that you also do one of the following:
 - a) Accompany it with the complete corresponding machine-readable source code, which must be distributed under the terms of sections 1 and 2 above on a medium customarily used for software interchange; or
 - b) Accompany it with a written offer, valid for at least three years, to give any third party, for a charge no more than your cost of physically performing source distribution, a complete machine-readable copy of the corresponding source code, to be distributed under the terms of sections 1 and 2 above on a medium customarily used for software interchange; or,

- c) Accompany it with the information you received as to the offer to distribute corresponding source code. (This alternative is allowed only for noncommercial distribution and only if you received the program in object code or executable form with such an offer, in accord with Subsection b above.)

The source code for a work means the preferred form of the work for making modifications to it. For an executable work, complete source code means all the source code for all modules it contains, plus any associated interface definition files, plus the scripts used to control compilation and installation of the executable. However, as a special exception, the source code distributed need not include anything that is normally distributed (in either source or binary form) with the major components (compiler, kernel, and so on) of the operating system on which the executable runs, unless that component itself accompanies the executable.

If distribution of executable or object code is made by offering access to copy from a designated place, then offering equivalent access to copy the source code from the same place counts as distribution of the source code, even though third parties are not compelled to copy the source along with the object code.

- 4. You may not copy, modify, sublicense, or distribute the Program except as expressly provided under this license. Any attempt otherwise to copy, modify, sublicense or distribute the Program is void, and will automatically terminate your rights under this license. However, parties who have received copies, or rights, from you under this license will not have their licenses terminated so long as such parties remain in full compliance.
- 5. You are not required to accept this license, since you have not signed it. However, nothing else grants you permission to modify or distribute the Program or its derivative works. These actions are prohibited by law if you do not accept this license. Therefore, by modifying or distributing the program (or any work based on the program), you indicate your acceptance of this license to do so, and all its terms and conditions for copying, distributing or modifying the program or works based on it.
- 6. Each time you redistribute the program (or any work based on the Program), the recipient automatically receives a license from the original licensor to copy, distribute or modify the Program subject to these terms and conditions. You may not impose any further restrictions on the recipients' exercise of the rights granted herein. You are not responsible for enforcing compliance by third parties to this license.

7. If, as a consequence of a court judgment or allegation of patent infringement or for any other reason (not limited to patent issues), conditions are imposed on you (whether by court order, agreement or otherwise) that contradict the conditions of this license, they do not excuse you from the conditions of this license. If you cannot distribute so as to satisfy simultaneously your obligations under this license and any other pertinent obligations, then as a consequence you may not distribute the program at all. For example, if a patent license would not permit royalty-free redistribution of the program by all those who receive copies directly or indirectly through you, then the only way you could satisfy both it and this license would be to refrain entirely from distribution of the program.

If any portion of this section is held invalid or unenforceable under any particular circumstance, the balance of the section is intended to apply and the section as a whole is intended to apply in other circumstances.

It is not the purpose of this section to induce you to infringe any patents or other property right claims or to contest validity of any such claims; this section has the sole purpose of protecting the integrity of the free software distribution system, which is implemented by public license practices. Many people have made generous contributions to the wide range of software distributed through that system in reliance on consistent application of that system; it is up to the author/donor to decide if he or she is willing to distribute software through any other system and a licensee cannot impose that choice.

This section is intended to make thoroughly clear what is believed to be a consequence of the rest of this license.

8. If the distribution and/or use of the program is restricted in certain countries either by patents or by copyrighted interfaces, the original copyright holder who places the program under this license may add an explicit geographical distribution limitation excluding those countries, so that distribution is permitted only in or among countries not thus excluded. In such case, this license incorporates the limitation as if written in the body of this license.
9. The Free Software Foundation may publish revised and/or new versions of the General Public License from time to time. Such new versions will be similar in spirit to the present version, but may differ in detail to address new problems or concerns.

Each version is given a distinguishing version number. If the program specifies a version number of this license which applies to it and "any later version", you have the option of following the terms and conditions either of that version or of

any later version published by the Free Software Foundation. If the program does not specify a version number of this license, you may choose any version ever published by the Free Software Foundation.

10. If you wish to incorporate parts of the program into other free programs whose distribution conditions are different, write to the author to ask for permission. For software which is copyrighted by the Free Software Foundation, write to the Free Software Foundation; we sometimes make exceptions for this. Our decision will be guided by the two goals of preserving the free status of all derivatives of our free software and of promoting the sharing and reuse of software generally.

NO WARRANTY

11. BECAUSE THE PROGRAM IS LICENSED FREE OF CHARGE, THERE IS NO WARRANTY FOR THE PROGRAM, TO THE EXTENT PERMITTED BY APPLICABLE LAW. EXCEPT WHEN OTHERWISE STATED IN WRITING THE COPYRIGHT HOLDERS AND/OR OTHER PARTIES PROVIDE THE PROGRAM "AS IS" WITHOUT WARRANTY OF ANY KIND, EITHER EXPRESSED OR IMPLIED, INCLUDING, BUT NOT LIMITED TO, THE IMPLIED WARRANTIES OF MERCHANTABILITY AND FITNESS FOR A PARTICULAR PURPOSE. THE ENTIRE RISK AS TO THE QUALITY AND PERFORMANCE OF THE PROGRAM IS WITH YOU. SHOULD THE PROGRAM PROVE DEFECTIVE, YOU ASSUME THE COST OF ALL NECESSARY SERVICING, REPAIR OR CORRECTION.
12. IN NO EVENT UNLESS REQUIRED BY APPLICABLE LAW OR AGREED TO IN WRITING WILL ANY COPYRIGHT HOLDER, OR ANY OTHER PARTY WHO MAY MODIFY AND/OR REDISTRIBUTE THE PROGRAM AS PERMITTED ABOVE, BE LIABLE TO YOU FOR DAMAGES, INCLUDING ANY GENERAL, SPECIAL, INCIDENTAL OR CONSEQUENTIAL DAMAGES ARISING OUT OF THE USE OR INABILITY TO USE THE PROGRAM (INCLUDING BUT NOT LIMITED TO LOSS OF DATA OR DATA BEING RENDERED INACCURATE OR LOSSES SUSTAINED BY YOU OR THIRD PARTIES OR A FAILURE OF THE PROGRAM TO OPERATE WITH ANY OTHER PROGRAMS), EVEN IF SUCH HOLDER OR OTHER PARTY HAS BEEN ADVISED OF THE POSSIBILITY OF SUCH DAMAGES.

END OF TERMS AND CONDITIONS

How to apply these terms to your new programs

If you develop a new program, and you want it to be of the greatest possible use to the public, the best way to achieve this is to make it free software which everyone can redistribute and change under these terms.

To do so, attach the following notices to the program. It is safest to attach them to the start of each source file to most effectively convey the exclusion of warranty; and each file should have at least the "copyright" line and a pointer to where the full notice is found.

one line to give the program's name and a brief idea of what it does.

Copyright (C) <year> <name of author>

This program is free software; you can redistribute it and/or modify it under the terms of the GNU General Public License as published by the Free Software Foundation; either version 2 of the license, or (at your option) any later version.

This program is distributed in the hope that it will be useful, but WITHOUT ANY WARRANTY; without even the implied warranty of MERCHANTABILITY or FITNESS FOR A PARTICULAR PURPOSE. See the GNU General Public License for more details.

You should have received a copy of the GNU General Public License along with this program; if not, write to the Free Software Foundation, Inc., 51 Franklin Street, Fifth Floor, Boston, MA 02110-1301 USA.

Also add information on how to contact you by electronic and paper mail.

If the program is interactive, make it output a short notice like this when it starts in an interactive mode:

Gnomovision version 69, Copyright (C) year name of author
Gnomovision comes with ABSOLUTELY NO WARRANTY; for details type 'show w'. This is free software, and you are welcome to redistribute it under certain conditions; type 'show c' for details.

The hypothetical commands 'show w' and 'show c' should show the appropriate parts of the General Public License. Of course, the commands you use may be called something other than 'show w' and 'show c'; they could even be mouse-clicks or menu items-whatever suits your program.

You should also get your employer (if you work as a programmer) or your school, if any, to sign a "copyright disclaimer" for the program, if necessary. Here is a sample; alter the names:

Yoyodyne, Inc., hereby disclaims all copyright interest in the program 'Gnomovision' (which makes passes at compilers) written by James Hacker.

signature of Ty Coon, 1 April 1989
Ty Coon, President of Vice

This General Public License does not permit incorporating your program into proprietary programs. If your program is a subroutine library, you may consider it more useful to permit linking proprietary applications with the library. If this is what you want to do, use the GNU Lesser General Public License instead of this license.

GNU LESSER GENERAL PUBLIC LICENSE

Version 2.1, February 1999

Copyright (C) 1991, 1999 Free Software Foundation, Inc. 51 Franklin Street, Fifth Floor, Boston, MA 02110-1301 USA
Everyone is permitted to copy and distribute verbatim copies of this license document, but changing it is not allowed.

[This is the first released version of the Lesser GPL. It also counts as the successor of the GNU Library Public License, version 2, hence the version number 2.1.]

Preamble

The licenses for most software are designed to take away your freedom to share and change it. By contrast, the GNU General Public Licenses are intended to guarantee your freedom to share and change free software - to make sure the software is free for all its users.

This license, the Lesser General Public License, applies to some specially designated software packages - typically libraries - of the Free Software Foundation and other authors who decide to use it. You can use it too, but we suggest you first think carefully about whether this license or the ordinary General Public License is the better strategy to use in any particular case, based on the explanations below.

When we speak of free software, we are referring to freedom of use, not price. Our General Public Licenses are designed to make sure that you have the freedom to distribute copies of free software (and charge for this service if you wish); that you receive source code or can get it if you want it; that you can change the software and use pieces of it in new free programs; and that you are informed that you can do these things.

To protect your rights, we need to make restrictions that forbid distributors to deny you these rights or to ask you to surrender these rights. These restrictions translate to certain responsibilities for you if you distribute copies of the library or if you modify it.

For example, if you distribute copies of the library, whether gratis or for a fee, you must give the recipients all the rights that we gave you. You must make sure that they, too, receive or can get the source code. If you link other code with the library, you must provide complete object files to the recipients, so that they can relink them with the library after making changes to the library and recompiling it. And you must show them these terms so they know their rights.

We protect your rights with a two-step method: (1) we copyright the library, and (2) we offer you this license, which gives you legal permission to copy, distribute and/or modify the library.

To protect each distributor, we want to make it very clear that there is no warranty for the free library. Also, if the library is modified by someone else and passed on, the recipients should know that what they have is not the original version, so that the original author's reputation will not be affected by problems that might be introduced by others.

Finally, software patents pose a constant threat to the existence of any free program. We wish to make sure that a company cannot effectively restrict the users of a free program by obtaining a restrictive license from a patent holder. Therefore, we insist that any patent license obtained for a version of the library must be consistent with the full freedom of use specified in this license.

Most GNU software, including some libraries, is covered by the ordinary GNU General Public License. This license, the GNU Lesser General Public License, applies to certain designated libraries, and is quite different from the ordinary General Public License. We use this license for certain libraries in order to permit linking those libraries into non-free programs.

When a program is linked with a library, whether statically or using a shared library, the combination of the two is legally speaking a combined work, a derivative of the original library. The ordinary General Public License therefore permits such linking only if the entire combination fits its criteria of freedom. The Lesser General Public License permits more lax criteria for linking other code with the library.

We call this license the "Lesser" General Public License because it does less to protect the user's freedom than the ordinary General Public License. It also provides other free software developers less of an advantage over competing non-free programs. These disadvantages are the reason we use the ordinary General Public License for many libraries. However, the Lesser license provides advantages in certain special circumstances.

For example, on rare occasions, there may be a special need to encourage the widest possible use of a certain library, so that it becomes a de-facto standard. To achieve this, non-free programs must be allowed to use the library. A more frequent case is that a free library does the same job as widely used non-free libraries. In this case, there is little to gain by limiting the free library to free software only, so we use the Lesser General Public License.

In other cases, permission to use a particular library in non-free programs enables a greater number of people to use a large body of free software. For example, permission to use the GNU C Library in non-free programs enables many more people to use the whole GNU operating system, as well as its variant, the GNU/Linux operating system.

Although the Lesser General Public License is less protective of the users' freedom, it does ensure that the user of a program that is linked with the Library has the freedom and the wherewithal to run that program using a modified version of the Library.

The precise terms and conditions for copying, distribution and modification follow. Pay close attention to the difference between a "work based on the library" and a "work that uses the library". The former contains code derived from the library, whereas the latter must be combined with the library in order to run.

GNU LESSER GENERAL PUBLIC LICENSE TERMS AND CONDITIONS FOR COPYING, DISTRIBUTION AND MODIFICATION

0. This license agreement applies to any software library or other program which contains a notice placed by the copyright holder or other authorized party saying it may be distributed under the terms of this Lesser General Public License (also called "this license"). Each license is addressed as "you".

A "library" means a collection of software functions and/or data prepared so as to be conveniently linked with application programs (which use some of those functions and data) to form executables.

The "Library", below, refers to any such software library or work which has been distributed under these terms. A "work based on the Library" means either the Library or any derivative work under copyright law: that is to say, a work containing the library or a portion of it, either verbatim or with modifications and/or translated straightforwardly into another language. (Hereinafter, translation is included without limitation in the term "modification".)

"Source code" for a work means the preferred form of the work for making modifications to it. For a library, complete source code means all the source code for all modules it contains, plus any associated interface definition files, plus the scripts used to control compilation and installation of the library.

Activities other than copying, distribution and modification are not covered by this license; they are outside its scope. The act of running a program using the Library is not restricted, and output from such a program is covered only if its contents constitute a work based on the library (independent of the use of the Library in a tool for writing it). Whether that is true depends on what the library does and what the program that uses the library does.

1. You may copy and distribute verbatim copies of the library's complete source code as you receive it, in any medium, provided that you conspicuously and appropriately publish on

each copy an appropriate copyright notice and disclaimer of warranty; keep intact all the notices that refer to this license and to the absence of any warranty; and distribute a copy of this license along with the Library.

You may charge a fee for the physical act of transferring a copy, and you may at your option offer warranty protection in exchange for a fee.

2. You may modify your copy or copies of the Library or any portion of it, thus forming a work based on the Library, and copy and distribute such modifications or work under the terms of section 1 above, provided that you also meet all of these conditions:

- a) The modified work must itself be a software library.
- b) You must cause the files modified to carry prominent notices stating that you changed the files and the date of any change.
- c) You must cause the whole of the work to be licensed at no charge to all third parties under the terms of this license.
- d) If a facility in the modified Library refers to a function or a table of data to be supplied by an application program that uses the facility, other than as an argument passed when the facility is invoked, then you must make a good faith effort to ensure that, in the event an application does not supply such function or table, the facility still operates, and performs whatever part of its purpose remains meaningful.

(For example, a function in a library to compute square roots has a purpose that is entirely well-defined independent of the application. Therefore, Subsection 2d requires that any application-supplied function or table used by this function must be optional: if the application does not supply it, the square root function must still compute square roots.)

These requirements apply to the modified work as a whole. If identifiable sections of that work are not derived from the library, and can be reasonably considered independent and separate works in themselves, then this license, and its terms, do not apply to those sections when you distribute them as separate works. But when you distribute the same sections as part of a whole which is a work based on the library, the distribution of the whole must be on the terms of this license, whose permissions for other licenses extend to the entire whole, and thus to each and every part regardless of who wrote it.

Thus, it is not the intent of this section to claim rights or contest your rights to work written entirely by you; rather, the intent is to exercise the right to control the distribution of derivative or collective works based on the library.

In addition, mere aggregation of another work not based on the library with the library (or with a work based on the library) on a volume of a storage or distribution medium does not bring the other work under the scope of this license.

3. You may opt to apply the terms of the ordinary GNU General Public License instead of this License to a given copy of the Library. To do this, you must alter all the notices that refer to this License, so that they refer to the ordinary GNU General Public License, version 2, instead of to this License. (If a newer version than version 2 of the ordinary GNU General Public License has appeared, then you can specify that version instead if you wish.) Do not make any other change in these notices.

Once this change is made in a given copy, it is irreversible for that copy, so the ordinary GNU General Public License applies to all subsequent copies and derivative works made from that copy.

This option is useful when you wish to copy part of the code of the library into a program that is not a library.

4. You may copy and distribute the library (or a portion or derivative of it, under Section 2) in object code or executable form under the terms of Sections 1 and 2 above provided that you accompany it with the complete corresponding machine-readable source code, which must be distributed under the terms of sections 1 and 2 above on a medium customarily used for software interchange.

If distribution of object code is made by offering access to copy from a designated place, then offering equivalent access to copy the source code from the same place satisfies the requirement to distribute the source code, even though third parties are not compelled to copy the source along with the object code.

5. A program that contains no derivative of any portion of the Library, but is designed to work with the Library by being compiled or linked with it, is called a “work that uses the Library”. Such a work, in isolation, is not a derivative work of the Library, and therefore falls outside the scope of this license.

However, linking a “work that uses the library” with the Library creates an executable that is a derivative of the Library (because it contains portions of the library), rather than a “work that uses the library”. The executable is therefore covered by this license. Section 6 states terms for distribution of such executable.

When a “work that uses the library” uses material from a header file that is part of the library, the object code for the work may be a derivative work of the library even though the source code is not.

Whether this is true is especially significant if the work can be linked without the library, or if the work is itself a library. The threshold for this to be true is not precisely defined by law.

If such an object file uses only numerical parameters, data structure layouts and accessories, and small macros and small inline functions (ten lines or less in length), then the use of

the object file is unrestricted, regardless of whether it is legally a derivative work. (Executable containing this object code plus portions of the library will still fall under Section 6.)

Otherwise, if the work is a derivative of the library, you may distribute the object code for the work under the terms of Section 6. Any executable containing that work also fall under Section 6, whether or not they are linked directly with the library itself.

6. As an exception to the sections above, you may also combine or link a “work that uses the library” with the library to produce a work containing portions of the library, and distribute that work under terms of your choice, provided that the terms permit modification of the work for the customer’s own use and reverse engineering for debugging such modifications.

You must give prominent notice with each copy of the work that the library is used in it and that the Library and its use are covered by this license. You must supply a copy of this license. If the work during execution displays copyright notices, you must include the copyright notice for the library among them, as well as a reference directing the user to the copy of this license. Also, you must do one of these things:

- a) Accompany the work with the complete corresponding machine-readable source code for the library including whatever changes were used in the work (which must be distributed under Sections 1 and 2 above); and, if the work is an executable linked with the Library, with the complete machine-readable “work that uses the Library”, as object code and/or source code, so that the user can modify the library and then relink to produce a modified executable containing the modified library. (It is understood that the user who changes the contents of definitions files in the library will not necessarily be able to recompile the application to use the modified definitions.)
- b) Use a suitable shared library mechanism for linking with the library. A suitable mechanism is one that (1) uses at run time a copy of the library already present on the user’s computer system, rather than copying library functions into the executable, and (2) will operate properly with a modified version of the library, if the user installs one, as long as the modified version is interface-compatible with the version that the work was made with.
- c) Accompany the work with a written offer, valid for at least three years, to give the same user the materials specified in Subsection 6, above, for a charge no more than the cost of performing this distribution.
- d) If distribution of the work is made by offering access to copy from a designated place, offer equivalent access to copy the above specified materials from the same place.
- e) Verify that the user has already received a copy of these materials or that you have already sent this user a copy.

For an executable, the required form of the “work that uses the library” must include any data and utility programs needed for reproducing the executable from it. However, as a special exception, the materials to be distributed need not include anything that is normally distributed (in either source or binary form) with the major components (compiler, kernel, and so on) of the operating system on which the executable runs, unless that component itself accompanies the executable.

It may happen that this requirement contradicts the license restrictions of other proprietary libraries that do not normally accompany the operating system. Such a contradiction means you cannot use both them and the library together in an executable that you distribute.

7. You may place library facilities that are a work based on the library side-by-side in a single library together with other library facilities not covered by this license, and distribute such a combined library, provided that the separate distribution of the work based on the Library and of the other library facilities is otherwise permitted, and provided that you do these two things:
 - a) Accompany the combined library with a copy of the same work based on the Library, uncombined with any other library facilities. This must be distributed under the terms of the sections above.
 - b) Give prominent notice with the combined library of the fact that part of it is a work based on the library, and explaining where to find the accompanying uncombined form of the same work.
8. You may not copy, modify, sublicense, link with, or distribute the library except as expressly provided under this license. Any attempt otherwise to copy, modify, sublicense, link with, or distribute the library is void, and will automatically terminate your rights under this license. However, parties who have received copies, or rights, from you under this license will not have their licenses terminated so long as such parties remain in full compliance.
9. You are not required to accept this license, since you have not signed it. However, nothing else grants you permission to modify or distribute the library or its derivative works. These actions are prohibited by law if you do not accept this license. Therefore, by modifying or distributing the library (or any work based on the library), you indicate your acceptance of this license to do so, and all its terms and conditions for copying, distributing or modifying the library or works based on it.
10. Each time you redistribute the library (or any work based on the Library), the recipient automatically receives a license from the original licensor to copy, distribute, link with or modify the library subject to these terms and conditions. You may not impose any further restrictions on the recipients’ exercise

of the rights granted herein.

You are not responsible for enforcing compliance by third parties with this license.

11. If, as a consequence of a court judgment or allegation of patent infringement or for any other reason (not limited to patent issues), conditions are imposed on you (whether by court order, agreement or otherwise) that contradict the conditions of this license, they do not excuse you from the conditions of this license. If you cannot distribute so as to satisfy simultaneously your obligations under this license and any other pertinent obligations, then as a consequence you may not distribute the library at all. For example, if a patent license would not permit royalty-free redistribution of the library by all those who receive copies directly or indirectly through you, then the only way you could satisfy both it and this license would be to refrain entirely from distribution of the library.

If any portion of this section is held invalid or unenforceable under any particular circumstance, the balance of the section is intended to apply, and the section as a whole is intended to apply in other circumstances.

It is not the purpose of this section to induce you to infringe any patents or other property right claims or to contest validity of any such claims; this section has the sole purpose of protecting the integrity of the free software distribution system which is implemented by public license practices. Many people have made generous contributions to the wide range of software distributed through that system in reliance on consistent application of that system; it is up to the author/donor to decide if he or she is willing to distribute software through any other system and a license cannot impose that choice.

This section is intended to make thoroughly clear what is believed to be a consequence of the rest of this license.

12. If the distribution and/or use of the library is restricted in certain countries either by patents or by copyrighted interfaces, the original copyright holder who places the library under this license may add an explicit geographical distribution limitation excluding those countries, so that distribution is permitted only in or among countries not thus excluded. In such case, this license incorporates the limitation as if written in the body of this license.
13. The Free Software Foundation may publish revised and/or new versions of the Lesser General Public License from time to time. Such new versions will be similar in spirit to the present version, but may differ in detail to address new problems or concerns. Each version is given a distinguishing version number. If the library specifies a version number of this license which applies to it and “any later version”, you have the option of following the terms and conditions either of that version or of any later version published by the Free Software Foundation.

APPENDIX

If the library does not specify a license version number, you may choose any version ever published by the Free Software Foundation.

14. If you wish to incorporate parts of the library into other free programs whose distribution conditions are incompatible with these, write to the author to ask for permission. For software which is copyrighted by the Free Software Foundation, write to the Free Software Foundation; we sometimes make exceptions for this. Our decision will be guided by the two goals of preserving the free status of all derivatives of our free software and of promoting the sharing and reuse of software generally.

NO WARRANTY

15. BECAUSE THE LIBRARY IS LICENSED FREE OF CHARGE, THERE IS NO WARRANTY FOR THE LIBRARY, TO THE EXTENT PERMITTED BY APPLICABLE LAW. EXCEPT WHEN OTHERWISE STATED IN WRITING THE COPYRIGHT HOLDERS AND/OR OTHER PARTIES PROVIDE THE LIBRARY "AS IS" WITHOUT WARRANTY OF ANY KIND, EITHER EXPRESSED OR IMPLIED, INCLUDING, BUT NOT LIMITED TO, THE IMPLIED WARRANTIES OF MERCHANTABILITY AND FITNESS FOR A PARTICULAR PURPOSE. THE ENTIRE RISK AS TO THE QUALITY AND PERFORMANCE OF THE LIBRARY IS WITH YOU. SHOULD THE LIBRARY PROVE DEFECTIVE, YOU ASSUME THE COST OF ALL NECESSARY SERVICING, REPAIR OR CORRECTION.

16. IN NO EVENT UNLESS REQUIRED BY APPLICABLE LAW OR AGREED TO IN WRITING WILL ANY COPYRIGHT HOLDER, OR ANY OTHER PARTY WHO MAY MODIFY AND/OR REDISTRIBUTE THE LIBRARY AS PERMITTED ABOVE, BE LIABLE TO YOU FOR DAMAGES, INCLUDING ANY GENERAL, SPECIAL, INCIDENTAL OR CONSEQUENTIAL DAMAGES ARISING OUT OF THE USE OR INABILITY TO USE THE LIBRARY (INCLUDING BUT NOT LIMITED TO LOSS OF DATA OR DATA BEING RENDERED INACCURATE OR LOSSES SUSTAINED BY YOU OR THIRD PARTIES OR A FAILURE OF THE LIBRARY TO OPERATE WITH ANY OTHER SOFTWARE), EVEN IF SUCH HOLDER OR OTHER PARTY HAS BEEN ADVISED OF THE POSSIBILITY OF SUCH DAMAGES.

END OF TERMS AND CONDITIONS

How to apply these terms to your new libraries

If you develop a new library, and you want it to be of the greatest possible use to the public, we recommend making it free software that everyone can redistribute and change. You can do so by permitting redistribution under these terms (or, alternatively, under the terms of the ordinary General Public License).

To apply these terms, attach the following notices to the library. It is safest to attach them to the start of each source file to most effectively convey the exclusion of warranty; and each file should have at least the "copyright" line and a pointer to where the full notice is found.

one line to give the library's name and a brief idea of what it does.
Copyright (C) <year> <name of author>

This library is free software; you can redistribute it and/or modify it under the terms of the GNU Lesser General Public License as published by the Free Software Foundation; either version 2.1 of the license, or (at your option) any later version.

This library is distributed in the hope that it will be useful, but WITHOUT ANY WARRANTY; without even the implied warranty of MERCHANTABILITY or FITNESS FOR A PARTICULAR PURPOSE. See the GNU Lesser General Public License for more details.

You should have received a copy of the GNU Lesser General Public License along with this library; if not, write to the Free Software Foundation, Inc., 51 Franklin Street, Fifth Floor, Boston, MA 02110-1301 USA

Also add information on how to contact you by electronic and paper mail.

You should also get your employer (if you work as a programmer) or your school, if any, to sign a "copyright disclaimer" for the library, if necessary. Here is a sample; alter the names:

Yoyodyne, Inc., hereby disclaims all copyright interest in the library 'Frob' (a library for tweaking knobs) written by James Random Hacker.

signature of Ty Coon, 1 April 1990
Ty Coon, President of Vice

MOZILLA PUBLIC LICENSE

Version 1.1

1. Definitions.

1.0.1. “Commercial use” means distribution or otherwise making the covered code available to a third party.

1.1. “Contributor” means each entity that creates or contributes to the creation of modifications.

1.2. “Contributor version” means the combination of the original code, prior modifications used by a contributor, and the modifications made by that particular contributor.

1.3. “Covered code” means the original code or modifications or the combination of the original code and modifications, in each case including portions thereof.

1.4. “Electronic distribution mechanism” means a mechanism generally accepted in the software development community for the electronic transfer of data.

1.5. “Executable” means covered code in any form other than source code.

1.6. “Initial developer” means the individual or entity identified as the initial Developer in the Source Code notice required by exhibit A.

1.7. “Larger work” means a work which combines covered code or portions thereof with code not governed by the terms of this License.

1.8. “License” means this document.

1.8.1. “Licensable” means having the right to grant, to the maximum extent possible, whether at the time of the initial grant or subsequently acquired, any and all of the rights conveyed herein.

1.9. “Modifications” means any addition to or deletion from the substance or structure of either the original code or any previous modifications. When covered code is released as a series of files, a modification is:

A. Any addition to or deletion from the contents of a file containing original code or previous modifications.

B. Any new file that contains any part of the original code or previous modifications.

1.10. “Original code” means source code of computer software

code which is described in the source code notice required by exhibit as original code, and which, at the time of its release under this license is not already covered code governed by this license.

1.10.1. “Patent claims” means any patent claim(s), now owned or hereafter acquired, including without limitation, method, process, and apparatus claims, in any patent licensable by grantor.

1.11. “Source code” means the preferred form of the covered code for making modifications to it, including all modules it contains, plus any associated interface definition files, scripts used to control compilation and installation of an executable, or source code differential comparisons against either the original code or another well known, available covered code of the contributor’s choice. The source code can be in a compressed or archival form, provided the appropriate decompression or de-archiving software is widely available for no charge.

1.12. “You” (or “Your”) means an individual or a legal entity exercising rights under, and complying with all of the terms of, this license or a future version of this license issued under section 6.1.

For legal entities, “You” includes any entity which controls, is controlled by, or is under common control with You. For purposes of this definition, “control” means (a) the power, direct or indirect, to cause the direction or management of such entity, whether by contract or otherwise, or (b) ownership of more than fifty percent (50%) of the outstanding shares or beneficial ownership of such entity.

2. Source Code License.

2.1. The initial developer grant.
The initial developer hereby grants You a world-wide, royalty-free, non-exclusive license, subject to third party intellectual property claims:

- a) under intellectual property rights (other than patent or trademark) licensable by initial developer to use, reproduce, modify, display, perform, sublicense and distribute the original code (or portions thereof) with or without modifications, and/or as part of a larger work; and
- (b) under patents claims infringed by the making, using or selling of original code, to make, have made, use, practice, sell, and offer for sale, and/or otherwise dispose of the original code (or portions thereof).

- (c) the licenses granted in this section 2.1(a) and (b) are effective on the date Initial developer first distributes original code under the terms of this license.
- (d) Notwithstanding section 2.1(b) above, no patent license is granted: 1) for code that You delete from the original Code; 2) separate from the original code; or 3) for infringements caused by: i) the modification of the original code or ii) the combination of the original code with other software or devices.

2.2. Contributor Grant.

Subject to third party intellectual property claims, each contributor hereby grants You a world-wide, royalty-free, non-exclusive license

- (a) under intellectual property rights (other than patent or trademark) licensable by contributor, to use, reproduce, modify, display, perform, sublicense and distribute the modifications created by such contributor (or portions thereof) either on an unmodified basis, with other modifications, as covered code and/or as part of a larger work; and
- (b) under patent claims infringed by the making, using, or selling of modifications made by that contributor either alone and/or in combination with its contributor version (or portions of such combination), to make, use, sell, offer for sale, have made, and/or otherwise dispose of: 1) modifications made by that contributor (or portions thereof); and 2) the combination of modifications made by that contributor with its contributor version (or portions of such combination).
- (c) the licenses granted in sections 2.2(a) and 2.2(b) are effective on the date contributor first makes commercial use of the covered code.
- (d) Notwithstanding section 2.2(b) above, no patent license is granted: 1) for any code that contributor has deleted from the contributor version; 2) separate from the contributor version; 3) for infringements caused by: i) third party modifications of contributor version or ii) the combination of modifications made by that contributor with other software (except as part of the contributor version) or other devices; or 4) under patent claims infringed by covered code in the absence of modifications made by that contributor.

3. Distribution Obligations.

3.1. Application of license.

The modifications which You create or to which you contribute are governed by the terms of this license, including without limitation section 2.2. The source code version of covered code may be distributed only under the terms of this license or a future version of this license released under section 6.1, and you must include a copy of this license with every copy of the source code you distribute.

You may not offer or impose any terms on any source code version that alters or restricts the applicable version of this license or the recipients' rights hereunder. However, you may include an additional document offering the additional rights described in section 3.5.

3.2. Availability of source code.

Any modification which you create or to which you contribute must be made available in source code form under the terms of this license either on the same media as an executable version or via an accepted electronic distribution mechanism to anyone to whom you made an executable version available; and if made available via electronic distribution mechanism, must remain available for at least twelve (12) months after the date it initially became available, or at least six (6) months after a subsequent version of that particular modification has been made available to such recipients. You are responsible for ensuring that the source code version remains available even if the electronic distribution mechanism is maintained by a third party.

3.3. Description of modifications.

You must cause all covered code to which you contribute to contain a file documenting the changes You made to create that covered code and the date of any change. You must include a prominent statement that the modification is derived, directly or indirectly, from original code provided by the initial developer and including the name of the initial developer in (a) the source code, and (b) in any notice in an executable version or related documentation in which you describe the origin or ownership of the covered code.

3.4. Intellectual property matters

(a) Third party claims.

If contributor has knowledge that a license under a third party's intellectual property rights is required to exercise the rights granted by such contributor under sections 2.1 or 2.2, contributor must include a text file with the source code distribution titled "LEGAL" which describes the claim and the party making the claim in sufficient detail that a recipient will know whom to contact. If contributor obtains such knowledge after the modification is made available as described in section 3.2, contributor shall promptly modify the LEGAL file in all copies contributor makes available thereafter and shall take other steps (such as notifying appropriate mailing lists or newsgroups) reasonably calculated to inform those who received the covered code that new knowledge has been obtained.

(b) Contributor APIs.

If contributor's modifications include an application programming interface and contributor has knowledge of patent licenses which are reasonably necessary to implement that API, contributor must also include this information in the LEGAL file.

(c) Representations.

contributor represents that, except as disclosed pursuant to section 3.4(a) above, contributor believes that contributor's modifications are contributor's original creation(s) and/or contributor has sufficient rights to grant the rights conveyed by this license.

3.5. Required notices.

You must duplicate the notice in exhibit A in each file of the source code. If it is not possible to put such notice in a particular source code file due to its structure, then You must include such notice in a location (such as a relevant directory) where a user would be likely to look for such a notice. If You created one or more modification(s), you may add your name as a contributor to the notice described in exhibit A. you must also duplicate this license in any documentation for the source code where You describe recipients' rights or ownership rights relating to covered code. You may choose to offer, and to charge a fee for, warranty, support, indemnity or liability obligations to one or more recipients of covered code. However, you may do so only on your own behalf, and not on behalf of the Initial developer or any contributor. You must make it absolutely clear than any such warranty, support, indemnity or liability obligation is offered by you alone, and You hereby agree to indemnify the Initial developer and every contributor for any liability incurred by the Initial developer or such contributor as a result of warranty, support, indemnity or liability terms you offer.

3.6. Distribution of executable versions.

You may distribute covered code in executable form only if the requirements of section 3.1-3.5 have been met for that covered code, and if you include a notice stating that the source code version of the covered code is available under the terms of this license, including a description of how and where you have fulfilled the obligations of section 3.2. The notice must be conspicuously included in any notice in an executable version, related documentation or collateral in which you describe recipients' rights relating to the covered code. You may distribute the executable version of covered code or ownership rights under a license of your choice, which may contain terms different from this license, provided that you are in compliance with the terms of this license and that the license for the executable version does not attempt to limit or alter the recipient's rights in the source code version from the rights set forth in this license. If you distribute the executable version under a different license you must make it absolutely clear that any terms which differ from this license are offered by you alone, not by the Initial developer or any contributor. You hereby agree to indemnify the initial developer and every contributor for any liability incurred by the initial developer or such contributor as a result of any such terms You offer.

3.7. Larger works.

You may create a larger work by combining covered code with other code not governed by the terms of this license and distribute the larger work as a single product. In such a case, you must make sure the requirements of this license are fulfilled for the covered code.

4. Inability to comply due to statute or regulation.

If it is impossible for you to comply with any of the terms of this license with respect to some or all of the covered code due to statute, judicial order, or regulation then you must: (a) comply with the terms of this license to the maximum extent possible; and (b) describe the limitations and the code they affect. Such description must be included in the LEGAL file described in section 3.4 and must be included with all distributions of the source code. Except to the extent prohibited by statute or regulation, such description must be sufficiently detailed for a recipient of ordinary skill to be able to understand it.

5. Application of this license.

This license applies to code to which the initial developer has attached the notice in exhibit A and to related covered code.

6. Versions of the license.

6.1. New versions.

Netscape communications corporation ("Netscape") may publish revised and/or new versions of the license from time to time. Each version will be given a distinguishing version number.

6.2. Effect of new versions.

Once covered code has been published under a particular version of the license, you may always continue to use it under the terms of that version. You may also choose to use such covered code under the terms of any subsequent version of the license published by netscape. No one other than netscape has the right to modify the terms applicable to covered code created under this license.

6.3. Derivative works.

If You create or use a modified version of this license (which you may only do in order to apply it to code which is not already covered code governed by this license), You must (a) rename Your license so that the phrases "Mozilla", "MOZILLAPL", "MOZPL", "Netscape", "MPL", "NPL" or any confusingly similar phrase do not appear in your license (except to note that your license differs from this license) and (b) otherwise make it clear that Your version of the license contains terms which differ from the Mozilla Public license and netscape Public License. (Filling in the name of the initial developer, original code or contributor in the notice described in exhibit A shall not of themselves be deemed to be modifications of this license.)

7. DISCLAIMER OF WARRANTY.

COVERED CODE IS PROVIDED UNDER THIS LICENSE ON AN "AS IS" BASIS, WITHOUT WARRANTY OF ANY KIND, EITHER EXPRESSED OR IMPLIED, INCLUDING, WITHOUT LIMITATION, WARRANTIES THAT THE COVERED CODE IS FREE OF DEFECTS, MERCHANTABILITY, FIT FOR A PARTICULAR PURPOSE OR NON-INFRINGEMENT. THE ENTIRE RISK AS TO THE QUALITY AND PERFORMANCE OF THE COVERED CODE IS WITH YOU. SHOULD ANY COVERED CODE PROVE DEFECTIVE IN ANY RESPECT, YOU (NOT THE INITIAL DEVELOPER OR ANY OTHER CONTRIBUTOR) ASSUME THE COST OF ANY NECESSARY SERVICING, REPAIR OR CORRECTION. THIS DISCLAIMER OF WARRANTY CONSTITUTES AN ESSENTIAL PART OF THIS LICENSE. NO USE OF ANY COVERED CODE IS AUTHORIZED HEREUNDER EXCEPT UNDER THIS DISCLAIMER.

8. TERMINATION.

- 8.1. This license and the rights granted hereunder will terminate automatically if you fail to comply with terms herein and fail to cure such breach within 30 days of becoming aware of the breach. All sublicenses to the covered code which are properly granted shall survive any termination of this license. Provisions which, by their nature, must remain in effect beyond the termination of this license shall survive.
- 8.2. If you initiate litigation by asserting a patent infringement claim (excluding declaratory judgment actions) against initial developer or a contributor (the initial developer or contributor against whom you file such action is referred to as "Participant") alleging that:
 - (a) such participant's contributor version directly or indirectly infringes any patent, then any and all rights granted by such participant to you under sections 2.1 and/or 2.2 of this license shall, upon 60 days notice from Participant terminate prospectively, unless if within 60 days after receipt of notice you either: (i) agree in writing to pay participant a mutually agreeable reasonable royalty for your past and future use of modifications made by such participant, or (ii) withdraw your litigation claim with respect to the contributor version against such participant. If within 60 days of notice, a reasonable royalty and payment arrangement are not mutually agreed upon in writing by the parties or the litigation claim is not withdrawn, the rights granted by participant to you under sections 2.1 and/or 2.2 automatically terminate at the expiration of the 60 day notice period specified above.
 - (b) any software, hardware, or device, other than such participant's contributor Version, directly or indirectly infringes any patent, then any rights granted to You by

such participant under sections 2.1 (b) and 2.2 (b) are revoked effective as of the date you first made, used, sold, distributed, or had made, modifications made by that participant.

- 8.3. If you assert a patent infringement claim against participant alleging that such participant's contributor version directly or indirectly infringes any patent where such claim is resolved (such as by license or settlement) prior to the initiation of patent infringement litigation, then the reasonable value of the licenses granted by such participant under sections 2.1 or 2.2 shall be taken into account in determining the amount or value of any payment or license.
- 8.4. In the event of termination under sections 8.1 or 8.2 above, all end user license agreements (excluding distributors and resellers) which have been validly granted by you or any distributor hereunder prior to termination shall survive termination.

9. LIMITATION OF LIABILITY.

UNDER NO CIRCUMSTANCES AND UNDER NO LEGAL THEORY, WHETHER TORT (INCLUDING NEGLIGENCE), CONTRACT, OR OTHERWISE, SHALL YOU, THE INITIAL DEVELOPER, ANY OTHER CONTRIBUTOR, OR ANY DISTRIBUTOR OF COVERED CODE, OR ANY SUPPLIER OF ANY OF SUCH PARTIES, BE LIABLE TO ANY PERSON FOR ANY INDIRECT, SPECIAL, INCIDENTAL, OR CONSEQUENTIAL DAMAGES OF ANY CHARACTER INCLUDING, WITHOUT LIMITATION, DAMAGES FOR LOSS OF GOODWILL, WORK STOPPAGE, COMPUTER FAILURE OR MALFUNCTION, OR ANY AND ALL OTHER COMMERCIAL DAMAGES OR LOSSES, EVEN IF SUCH PARTY SHALL HAVE BEEN INFORMED OF THE POSSIBILITY OF SUCH DAMAGES. THIS LIMITATION OF LIABILITY SHALL NOT APPLY TO LIABILITY FOR DEATH OR PERSONAL INJURY RESULTING FROM SUCH PARTY'S NEGLIGENCE TO THE EXTENT APPLICABLE LAW PROHIBITS SUCH LIMITATION. SOME JURISDICTIONS DO NOT ALLOW THE EXCLUSION OR LIMITATION OF INCIDENTAL OR CONSEQUENTIAL DAMAGES, SO THIS EXCLUSION AND LIMITATION MAY NOT APPLY TO YOU.

10. U.S. GOVERNMENT END USERS.

The covered code is a "commercial item," as that term is defined in 48 C.F.R. 2.101 (Oct. 1995), consisting of "commercial computer software" and "commercial computer software documentation," as such terms are used in 48 C.F.R. 12.212 (Sept. 1995). Consistent with 48 C.F.R. 12.212 and 48 C.F.R. 227.7202-1 through 227.7202-4 (June 1995), all U.S. Government end users acquire covered code with only those rights set forth herein.

11. MISCELLANEOUS.

This license represents the complete agreement concerning subject matter hereof. If any provision of this license is held to be unenforceable, such provision shall be reformed only to the extent necessary to make it enforceable. This License shall be governed by California law provisions (except to the extent applicable law, if any, provides otherwise), excluding its conflict-of-law provisions. With respect to disputes in which at least one party is a citizen of, or an entity chartered or registered to do business in the united states of america, any litigation relating to this License shall be subject to the jurisdiction of the federal courts of the northern district of california, with venue lying in santa clara county, california, with the losing party responsible for costs, including without limitation, court costs and reasonable attorneys' fees and expenses. The application of the united nations convention on contracts for the International sale of goods is expressly excluded. Any law or regulation which provides that the language of a contract shall be construed against the drafter shall not apply to this license.

12. RESPONSIBILITY FOR CLAIMS.

As between initial developer and the contributors, each party is responsible for claims and damages arising, directly or indirectly, out of its utilization of rights under this license and you agree to work with initial developer and contributors to distribute such responsibility on an equitable basis. Nothing herein is intended or shall be deemed to constitute any admission of liability.

13. MULTIPLE-LICENSED CODE.

Initial developer may designate portions of the covered code as "Multiple-Licensed". "Multiple-Licensed" means that the initial developer permits you to utilize portions of the covered code under your choice of the NPL or the alternative licenses, if any, specified by the initial developer in the file described in exhibit A.

EXHIBIT A -Mozilla Public License.

The contents of this file are subject to the Mozilla Public License Version 1.1 (the "license"); you may not use this file except in compliance with the License. You may obtain a copy of the license at <http://www.mozilla.org/MPL/>

Software distributed under the license is distributed on an "AS IS" basis, WITHOUT WARRANTY OF ANY KIND, either express or implied. See the license for the specific language governing rights and limitations under the License.

The Original Code is _____.

The Initial Developer of the Original Code is _____.

Portions created by _____ are Copyright (C) _____ All Rights Reserved.

Contributor(s): _____.

Alternatively, the contents of this file may be used under the terms of the ____ license (the "[] License"), in which case the provisions of [] license are applicable instead of those above. If you wish to allow use of your version of this file only under the terms of the [] license and not to allow others to use your version of this file under the MPL, indicate your decision by deleting the provisions above and replace them with the notice and other provisions required by the [] license. If you do not delete the provisions above, a recipient may use your version of this file under either the MPL or the [] license."

NOTE: The text of this exhibit A may differ slightly from the text of the notices in the source code files of the original code. You should use the text of this exhibit A rather than the text found in the original code/source code for Your modifications.

LEGAL NOTICE

IMPORTANT NOTICE RELATING TO NETWORK SERVICES

All content and services accessible through this device belong to third parties and are protected by copyright, patent, trademark and/or other intellectual property laws. Such content and services are provided solely for your personal noncommercial use. You may not use any content or services in a manner that has not been authorized by the content owner or service provider. Without limiting the foregoing, unless expressly authorized by the applicable content owner or service provider, you may not copy, upload, post, transmit, translate, sell, modify, create derivative works, or distribute in any manner or medium any content or services displayed through this device.

YOU EXPRESSLY ACKNOWLEDGE AND AGREE THAT THE DEVICE AND ALL THIRD PARTY CONTENT AND SERVICES ARE PROVIDED "AS IS" WITHOUT WARRANTY OF ANY KIND, EITHER EXPRESS OR IMPLIED. LG ELECTRONICS EXPRESSLY DISCLAIMS ALL WARRANTIES AND CONDITIONS WITH RESPECT TO ANY CONTENT AND SERVICES, EITHER EXPRESS OR IMPLIED, INCLUDING BUT NOT LIMITED TO, WARRANTIES OF MERCHANTABILITY, OF SATISFACTORY QUALITY, FITNESS FOR A PARTICULAR PURPOSE, AND NON-INFRINGEMENT OF THIRD PARTY RIGHTS. LG DOES NOT GUARANTEE THE ACCURACY, VALIDITY, TIMELINESS, LEGALITY, OR COMPLETENESS OF ANY CONTENT OR SERVICE MADE AVAILABLE THROUGH THIS DEVICE AND DOES NOT WARRANT THAT THE DEVICE OR SERVICES WILL MEET YOUR REQUIREMENTS, OR THAT OPERATION OF THE DEVICE OR SERVICES WILL BE UNINTERRUPTED OR ERROR-FREE. UNDER NO CIRCUMSTANCES, INCLUDING NEGLIGENCE, SHALL LG BE LIABLE, WHETHER IN CONTRACT OR TORT, FOR ANY DIRECT, INDIRECT, INCIDENTAL, SPECIAL OR CONSEQUENTIAL DAMAGES, OR ANY OTHER DAMAGES ARISING OUT OF, ANY INFORMATION CONTAINED IN, OR ANY CONTENT OR SERVICE ACCESSED BY YOU OR ANY THIRD PARTY, EVEN IF ADVISED OF THE POSSIBILITY OF SUCH DAMAGES.

Third party services may be changed, suspended, removed, terminated or interrupted, or access may be disabled at any time, without notice, and LG makes no representation or warranty that any content or service will remain available for any period of time. Content and services are transmitted by third parties by means of networks and transmission facilities over which LG has no control. LG may impose limits on the use of or access to certain services or content, in any case and without notice or liability. LG EXPRESSLY DISCLAIMS ANY RESPONSIBILITY OR LIABILITY FOR ANY CHANGE, INTERRUPTION, DISABLING, REMOVAL OF OR SUSPENSION OF ANY CONTENT OR SERVICE MADE AVAILABLE THROUGH THIS DEVICE.

LG is neither responsible nor liable for customer service related to the content and services. Any question or request for service relating to the content or services should be made directly to the respective content and service providers.

LG Electronics Inc.