

**Model 130.887650**

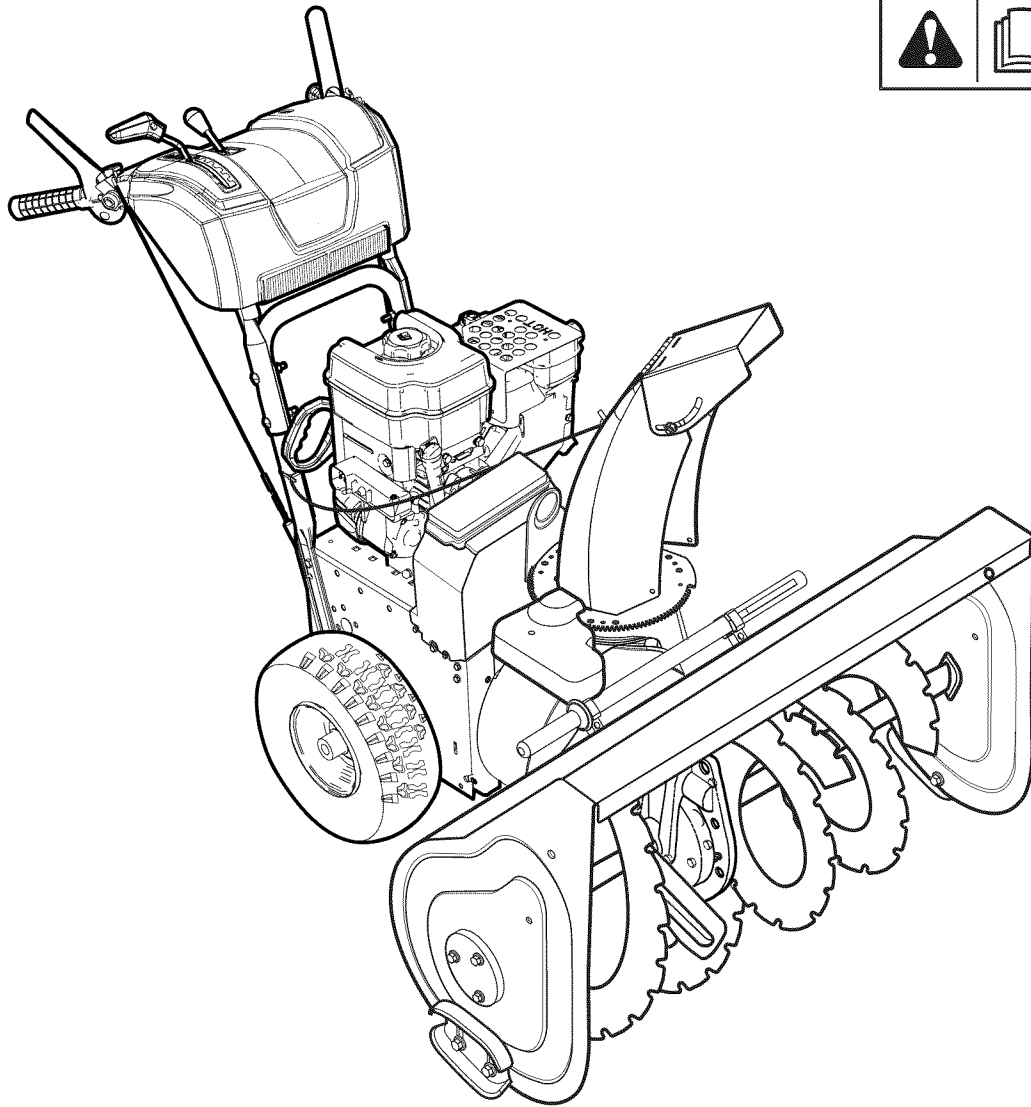

## **Mid Frame Snow Thrower**

<b>Mfg. No.</b>	<b>Description</b>
1695734	Dual Stage Snow Thrower, 11.5 TP, 27 Inch

**Thank you** for purchasing this quality-built Snapper snow thrower. We're pleased that you've placed your confidence in the Snapper brand. When operated and maintained according to the instructions in this manual, your Snapper product will provide many years of dependable service.

**This manual contains** safety information to make you aware of the hazards and risks associated with snow throwers and how to avoid them. This snow thrower is designed and intended only for snow throwing and is not intended for any other purpose. It is important that you read and understand these instructions thoroughly before attempting to start or operate this equipment. **This snow thrower requires final assembly before use.** Refer to the Quick Start Guide for instructions on final assembly procedures. Follow the instructions completely. **Save these instructions for future reference.**

**Product Identification Tag**



PRODUCT REFERENCE DATA	
Model Description Name/Number	
Unit MFG Number	Unit SERIAL Number
Mower Deck MFG Number	Mower Deck SERIAL Number
Dealer Name	Date Purchased
ENGINE REFERENCE DATA	
Engine Make	Engine Model
Engine Type/Spec	Engine Code/Serial Number

**When contacting your authorized dealer for replacement parts, service, or information you MUST have these numbers.**

Record your model name/number, manufacturer's identification numbers, and engine serial numbers in the space provided for easy access. These numbers can be found in the locations shown.

The Illustrated Parts List for this machine can be downloaded from [www.snapper.com](http://www.snapper.com). Please provide model and serial number when ordering replacement parts.

Snapper Products  
 535 Macon St.  
 McDonough, GA 30253  
 1-800-317-7833  
 snapper.com

<b>OPERATOR SAFETY</b> .....	<b>4</b>
<b>FEATURES AND CONTROLS</b> .....	<b>10</b>
<b>OPERATION</b> .....	<b>12</b>
BEFORE OPERATING SNOW THROWER .....	12
OPERATE THE SNOW THROWER .....	12
STOP THE SNOW THROWER .....	13
TRACTION LOCK PIN .....	13
DISCHARGE CHUTE AND DEFLECTOR .....	13
CHECK THE OIL (BEFORE STARTING ENGINE) .....	14
FILL THE FUEL TANK .....	14
START THE ENGINE .....	15
STOP THE ENGINE .....	16
CLEAR A CLOGGED DISCHARGE CHUTE .....	17
OPERATING TIPS .....	17
<b>MAINTENANCE</b> .....	<b>18</b>
SERVICE RECOMMENDATIONS .....	18
LUBRICATE AUGER GEAR BOX .....	19
LUBRICATE AUGER SHAFT FITTINGS .....	19
LUBRICATE CONTROL LEVER LINKAGE .....	19
LUBRICATE DISCHARGE CHUTE AND DEFLECTOR .....	19
ENGINE MAINTENANCE .....	20
CHANGE THE SPARK PLUG .....	21
ADJUST SKID HEIGHT .....	22
BELT ADJUSTMENT .....	23
BELT GUIDE ADJUSTMENT .....	23
SPEED CONTROL ROD ADJUSTMENT .....	24
CHECK AND ADJUST THE CABLES .....	24
AUGER CONTROL CABLE ADJUSTMENT .....	24
TRACTION CONTROL CABLE ADJUSTMENT .....	25
CHUTE ROTATION MOTOR ADJUSTMENT .....	26
AUGER SHEAR PIN REPLACEMENT .....	26
CHECK THE TIRES .....	27
<b>STORAGE</b> .....	<b>28</b>
OFF SEASON STORAGE .....	28
LUBRICATE HEX SHAFT AND CHAINS .....	28
REMOVE FROM STORAGE .....	28
<b>TROUBLESHOOTING</b> .....	<b>29</b>
<b>WARRANTIES</b> .....	<b>31</b>
<b>SPECIFICATIONS</b> .....	<b>33</b>

# OPERATOR SAFETY

## DANGER - Amputation Hazard







The discharge chute contains a rotating impeller to throw snow. Never clear or unclog the discharge chute with your hands. Fingers can quickly become caught and traumatic amputation or severe laceration will result. Always use a clean-out tool to clear or unclog the discharge chute.

 <b>DANGER</b>
<ul style="list-style-type: none"> <li>• Hand contact with the rotating impeller inside the discharge chute is the most common cause of injury associated with snow throwers.</li> <li>• This snow thrower is capable of amputating hands and feet, and throwing objects. Read and observe all the safety instructions in this manual. Failure to do so will result in death or serious injury.</li> </ul>













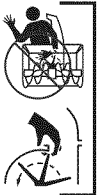

## Safety Alert Symbol and Signal Words

The safety alert symbol  and signal word (DANGER, WARNING, CAUTION, or NOTICE) is used to indicate the likelihood and potential severity of personal injury and/or damage to the product. In addition, a hazard symbol may be used to represent the type of hazard.

-  **DANGER** indicates a hazard which, if not avoided, **will result in death or serious injury.**
-  **WARNING** indicates a hazard which, if not avoided, **could result in death or serious injury.**
-  **CAUTION** indicates a hazard which, if not avoided, **could result in minor or moderate injury.**
- NOTICE** indicates a situation that **could result in damage to the product.**

 <b>WARNING</b>
U.S.A. Models: Certain components in this product and its related accessories contain chemicals known to the state of California to cause cancer, birth defects, or other reproductive harm. Wash hands after handling.

## Hazard Symbols and Meanings

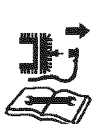
	Safety Alert – Identifies safety information about hazards that can result in personal injury.		
	Operator's Manual – Read and understand before performing any activity or running snow thrower.		
	Rotating Impeller		Keep a Safe Distance from Snow Thrower
	Rotating Auger		Rotating Gears
	Never Reach into Rotating Parts		Thrown Objects
	Fire		Explosion
	Shock		Toxic Fumes
	Hot Surface		Recommended Ear Protection for Extended Use
	Shut off engine and remove spark plug connector before performing maintenance or repair work.		

 <b>WARNING</b>
U.S.A. Models: The engine exhaust from this product contains chemicals known to the State of California to cause cancer, birth defects, or other reproductive harm.

 <b>WARNING</b>
U.S.A. Models: Battery posts, terminals, and related accessories contain lead and lead components - chemicals known to the State of California to cause cancer and reproductive harm. Wash hands after handling.

**Control Symbols on Equipment**

	Oil		Forward
	Fuel		Neutral
	On Off		Reverse
	Choke Off		
	Choke On		
	Stop		Electric Start - Engage (Down) & Disengage (Up)
	Slow		Engine - Run
	Fast		Engine - Stop
	Traction Control - Engage (Down)		Auger Control - Engage (Down)
	Auger Clutch		Chute Deflector (Up and Down)
	Discharge Chute (Left and Right)		Heated Hand Grips (High and Low)

Easy-Turn™ Traction Control	Free-Hand™ Control

**Read the Manual**

<b>DANGER</b>	
	Read, understand, and follow all the instructions on the snow thrower and in the operator's manual before operating this unit.
	Failure to observe the safety instructions in this manual will result in death or serious injury.
<ul style="list-style-type: none"> <li>• Be thoroughly familiar with the controls and the proper use of the snow thrower.</li> <li>• Make sure you are properly trained before operating the snow thrower.</li> <li>• Know how to stop the unit and disengage the controls quickly.</li> <li>• Never allow anyone to operate the snow thrower without proper instruction.</li> <li>• Always follow the instructions in the operator's manual, if the snow thrower will be stored for an extended period.</li> <li>• Maintain or replace safety and instruction labels as necessary.</li> <li>• Never attempt to make major repairs on the snow thrower unless you have been properly trained. Improper servicing of the snow thrower can result in hazardous operation, equipment damage, and voiding of the product warranty.</li> </ul>	



**Discharge Chute**

<b>DANGER</b>	
	Discharge chute contains rotating impeller to throw snow. Never clear or unclog the discharge chute with your hands. Fingers can quickly become caught in the impeller. Always use a clean-out tool.
	Failure to observe these safety instructions will result in traumatic amputation or severe laceration.
<p><b>TO SAFELY CLEAR A CLOGGED DISCHARGE CHUTE</b></p> <p> <b>DANGER:</b> Hand contact with the rotating impeller inside the discharge chute is the most common cause of injury associated with snow throwers. Never use your hands to clean out the discharge chute.</p> <p><b>FOLLOW THESE INSTRUCTIONS:</b></p> <ol style="list-style-type: none"> <li>1. Shut OFF the engine.</li> <li>2. Wait 10 seconds to be sure the impeller blades have stopped rotating.</li> <li>3. Always use a clean-out tool, not your hands.</li> </ol>	





**NOTE:** Not all control symbols shown on this page will appear on your snow thrower. See **FEATURES AND CONTROLS** section for the applicable symbols.

# OPERATOR SAFETY

## Operation and Equipment Safety

	<p style="text-align: center;"> <b>DANGER</b></p> <p>This snow thrower is only as safe as the operator. If it is misused, or not properly maintained, it can be dangerous. Remember you are responsible for your safety and that of those around you.</p>
<ul style="list-style-type: none"><li>• Keep the area of operation clear of all persons, particularly small children and pets.</li><li>• Thoroughly inspect the area where the snow thrower will be used and remove all doormats, sleds, boards, wires, and other foreign objects.</li><li>• Do not operate the snow thrower without wearing adequate winter clothing.</li><li>• Wear footwear that will improve footing on slippery surfaces.</li><li>• Use caution to avoid slipping or falling especially when operating the snow thrower in reverse.</li><li>• Never operate the snow thrower without good visibility or light. Always be sure of your footing, and keep a firm hold on the handles.</li><li>• Do not clear snow across the face of slopes. Use extreme caution when changing direction on slopes. Do not attempt to clear steep slopes.</li><li>• Do not overload the machine capacity by attempting to clear snow too quickly.</li><li>• Never operate the snow thrower at high transport speeds on slippery surfaces. Look behind the snow thrower and use care when operating in reverse.</li><li>• Do not use the snow thrower on surfaces above ground level such as roofs of residences, garages, porches, or other such structures or buildings.</li><li>• Operators should evaluate their ability to operate the snow thrower safely enough to protect themselves and others from injury.</li><li>• The snow thrower is intended to remove snow only. Do not use the snow thrower for any other purpose.</li><li>• Do not carry passengers.</li><li>• After striking a foreign object, shut OFF the engine, disconnect the cord on electric motors, thoroughly inspect the snow thrower for any damage, and repair the damage before restarting and operating the snow thrower.</li><li>• If the snow thrower vibrates abnormally, shut OFF the engine. Vibration is generally a warning of trouble. See an authorized dealer if necessary for repairs.</li><li>• For models equipped with electric starting motors, disconnect the power cord after the engine starts.</li></ul>	

## Fuel Handling

  	<p style="text-align: center;"> <b>DANGER</b></p> <p>Fuel and its vapors are extremely flammable and explosive. Always handle fuel with extreme care. Failure to observe these safety instructions can cause a fire or explosion which will result in severe burns or death.</p>
<p><b>WHEN ADDING FUEL</b></p> <ul style="list-style-type: none"><li>• Turn off engine and let cool at least 2 minutes before removing the fuel cap and adding fuel.</li><li>• Fill fuel tank outdoors or in a well ventilated area.</li><li>• Do not overfill the fuel tank. To allow for the expansion of gasoline, do not fill above the bottom of the fuel tank neck.</li><li>• Keep fuel away from sparks, open flames, pilot lights, heat, and other ignition sources.</li><li>• Check fuel lines, cap, and fittings frequently for cracks or leaks. Replace if necessary.</li><li>• Use an approved fuel container.</li><li>• If fuel spills, wait until it evaporates before starting engine.</li></ul> <p><b>WHEN STARTING ENGINE</b></p> <ul style="list-style-type: none"><li>• Ensure that spark plug, muffler, fuel cap, and air cleaner (if equipped) are in place and secured.</li><li>• Do not crank the engine with the spark plug removed.</li><li>• If fuel is spilled, do not attempt to start the engine, but move the snow thrower away from the area of the spill, and avoid creating any source of ignition, until the fuel vapors have dissipated.</li><li>• Do not over-prime the engine. Follow the engine starting instructions in this manual.</li><li>• If the engine floods, set choke (if equipped) to OPEN/RUN position, move throttle (if equipped) to FAST position and crank until engine starts.</li></ul> <p><b>WHEN OPERATING EQUIPMENT</b></p> <ul style="list-style-type: none"><li>• Do not tip the snow thrower at an angle which causes the fuel to spill.</li><li>• Do not choke the carburetor to stop the engine.</li><li>• Never run the engine with the air cleaner assembly (if equipped) or the air filter (if equipped) removed.</li></ul> <p><b>WHEN CHANGING OIL</b></p> <ul style="list-style-type: none"><li>• If you drain the oil from the top oil fill tube, the fuel tank must be empty or fuel can leak out and result in a fire or explosion.</li></ul> <p><b>WHEN TRANSPORTING EQUIPMENT</b></p> <ul style="list-style-type: none"><li>• Transport with fuel tank EMPTY, or with fuel shut-off valve OFF.</li></ul> <p><b>WHEN STORING GASOLINE OR EQUIPMENT WITH FUEL IN TANK</b></p> <ul style="list-style-type: none"><li>• Store away from furnaces, stoves, water heaters, or other appliances that have pilot light or other ignition source because they can ignite fuel vapors.</li></ul>	

## Moving Parts

	<p align="center"><b>⚠ DANGER</b></p> <p>Keep hands, feet, and clothing away from rotating parts. Rotating parts can contact or entangle hands, feet, hair, clothing, or accessories.</p> <p>Failure to observe these safety instructions will result in traumatic amputation or severe laceration.</p>
<ul style="list-style-type: none"> <li>• Whenever cleaning, repairing, or inspecting the snow thrower, make sure the engine is OFF, spark plug wire is disconnected, and all moving parts have stopped.</li> <li>• Do not put hands or feet near or under rotating parts. Keep clear of the discharge opening at all times.</li> <li>• Never operate the snow thrower without proper guards, and other safety devices in place and working.</li> <li>• Never leave the snow thrower unattended while engine is running. Always disengage the auger and traction controls, stop engine, and remove keys.</li> <li>• Keep all loose clothing away from the front of the snow thrower and auger. Scarves, mittens, dangling drawstrings, loose clothes, and pants can quickly become caught in the rotating device and amputation will occur. Tie up long hair and remove jewelry.</li> <li>• Run the machine a few minutes after discharging snow to prevent freeze-up of the collector/impeller.</li> <li>• Disengage power to the collector/impeller when snow thrower is transported or not in use.</li> </ul>	

## Thrown Objects

	<p align="center"><b>⚠ DANGER</b></p> <p>Objects can be picked up by auger and thrown from chute. Never discharge snow toward bystanders or allow anyone in front of the snow thrower. Failure to observe these safety instructions will result in death or serious injury.</p>
<ul style="list-style-type: none"> <li>• Always wear safety glasses or eye shields while during operation, and while performing an adjustment or repair.</li> <li>• Always be aware of the direction the snow is being thrown. Nearby pedestrians, pets, or property may be harmed by objects being thrown.</li> <li>• Be aware of your environment while operating the snow thrower. Running over items such as, gravel, doormats, newspapers, toys, and rocks hidden under snow, can all be thrown from the chute or jam in the auger.</li> <li>• Use extreme caution when operating on or crossing gravel drives, walks, or roads.</li> <li>• Adjust the collector housing height to clear gravel or crushed rock surface.</li> <li>• Never operate the snow thrower near glass enclosures, automobiles, window wells, drop-offs, and the like without proper adjustment of the discharge chute angle.</li> <li>• Familiarize yourself with the area in which you plan to operate the snow thrower. Mark off boundaries of walkways and driveways.</li> </ul>	

## Children

	<p align="center"><b>⚠ DANGER</b></p> <p>Tragic accidents can occur if the operator is not alert to the presence of children. Children are often attracted to the unit and the operating activity. Never assume that children will remain where you last saw them.</p>
<ul style="list-style-type: none"> <li>• Keep children out of the area during operation. Children are often attracted to the equipment. Be mindful of all persons present.</li> <li>• Be alert and turn unit off if children enter the area.</li> <li>• Never allow children to operate the unit.</li> <li>• Use extra care when approaching blind corners, shrubs, trees, or other objects that may obscure vision. Children may be present.</li> </ul>	

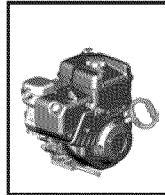

## Engine Safety

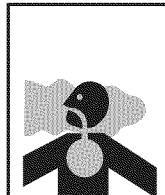

	<p align="center"><b>⚠ DANGER</b></p> <p>Safe operation of the snow thrower requires the proper care and maintenance of the engine. Failure to observe the safety instructions in this manual will result in death or serious injury.</p>
<ul style="list-style-type: none"> <li>• Disengage all clutches and shift into neutral before starting the engine.</li> <li>• Let the engine adjust to outdoor temperatures before starting to clear snow.</li> <li>• Use a grounded three-wire plug-in for all snow throwers equipped with electric drive motors or electric starting motors.</li> </ul>	

	<p align="center"><b>⚠ DANGER</b></p> <p>Engines give off carbon monoxide, an odorless, colorless, poison gas. Breathing carbon monoxide can cause nausea, fainting, or death.</p>
<ul style="list-style-type: none"> <li>• Start and run engine outdoors.</li> <li>• Do not run the engine in an enclosed area, even if doors or windows are open.</li> </ul>	

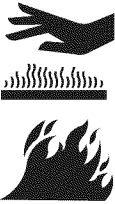

# OPERATOR SAFETY

## Engine Safety (Continued)

	 <b>WARNING</b>
	<p>Starting engine creates sparking. Sparking can ignite nearby flammable gases. Explosion and fire could result.</p>
<ul style="list-style-type: none"> <li>• If there is natural or LP gas leakage in area, do not start engine.</li> <li>• Do not use pressurized starting fluids because vapors are flammable.</li> </ul>	

	 <b>WARNING</b>
	<p>Running the engine produces heat. Engine parts, especially muffler, become extremely hot. Failure to observe these safety instructions could result in severe thermal burns on contact.</p>
<ul style="list-style-type: none"> <li>• Never touch a hot engine or muffler. Allow muffler, engine cylinder, and fins to cool before touching.</li> <li>• Remove debris from muffler area and cylinder area.</li> <li>• Install and maintain in working order a spark arrester before using equipment on forest-covered, grass-covered, or brush-covered unimproved land.</li> <li>• <b>U.S.A. Models:</b> It is a violation of California Public Resource Code Section 4442 to use or operate the engine on or near any forest-covered, brush-covered, or grass-covered land unless the exhaust system is equipped with a spark arrester meeting any applicable local or state laws. Other states or federal areas may have similar laws.</li> </ul>	

## Maintenance and Storage

	 <b>WARNING</b>
	<p>This snow thrower must be properly maintained to ensure safe operation and performance. Failure to observe the safety instructions in this manual could result in death or serious injury.</p>
<ul style="list-style-type: none"> <li>• When performing any maintenance or repairs on the snow thrower, shut OFF the engine, disconnect spark plug wire, and keep the wire away from the plug to prevent someone from accidentally starting the engine.</li> <li>• Check shear bolts and other hardware at frequent intervals for proper tightness to be sure the snow thrower is in safe working condition.</li> <li>• Keep nuts and bolts tight and keep snow thrower in good condition.</li> <li>• Never tamper with safety devices. Check their proper operation regularly and make necessary repairs if they are not functioning properly.</li> <li>• Components are subject to wear, damage, and deterioration. Frequently check components and replace with recommended parts, when necessary.</li> <li>• Check control operation frequently. Adjust and service as required.</li> <li>• Use only factory authorized replacement parts when making repairs.</li> <li>• Always comply with factory specifications on all settings and adjustments.</li> <li>• Only authorized service locations should be utilized for major service and repair requirements.</li> <li>• Use only attachments and accessories approved by the factory (such as wheel weights, counterweights, or cabs).</li> <li>• Never attempt to make any adjustments while the engine is running (except when specifically recommended by the factory).</li> </ul>	





Look for this symbol to indicate important safety precautions. This symbol indicates: "Attention! Become Alert! Your Safety Is At Risk."



**WARNING:** If any safety decals become worn or damaged and cannot be read, order replacement decals from your local dealer.

Before operating your snow thrower, read the safety decals as shown on your snow thrower. The cautions and warnings are for your safety. To avoid a personal injury or damage to your snow thrower, understand and follow all the safety decals.

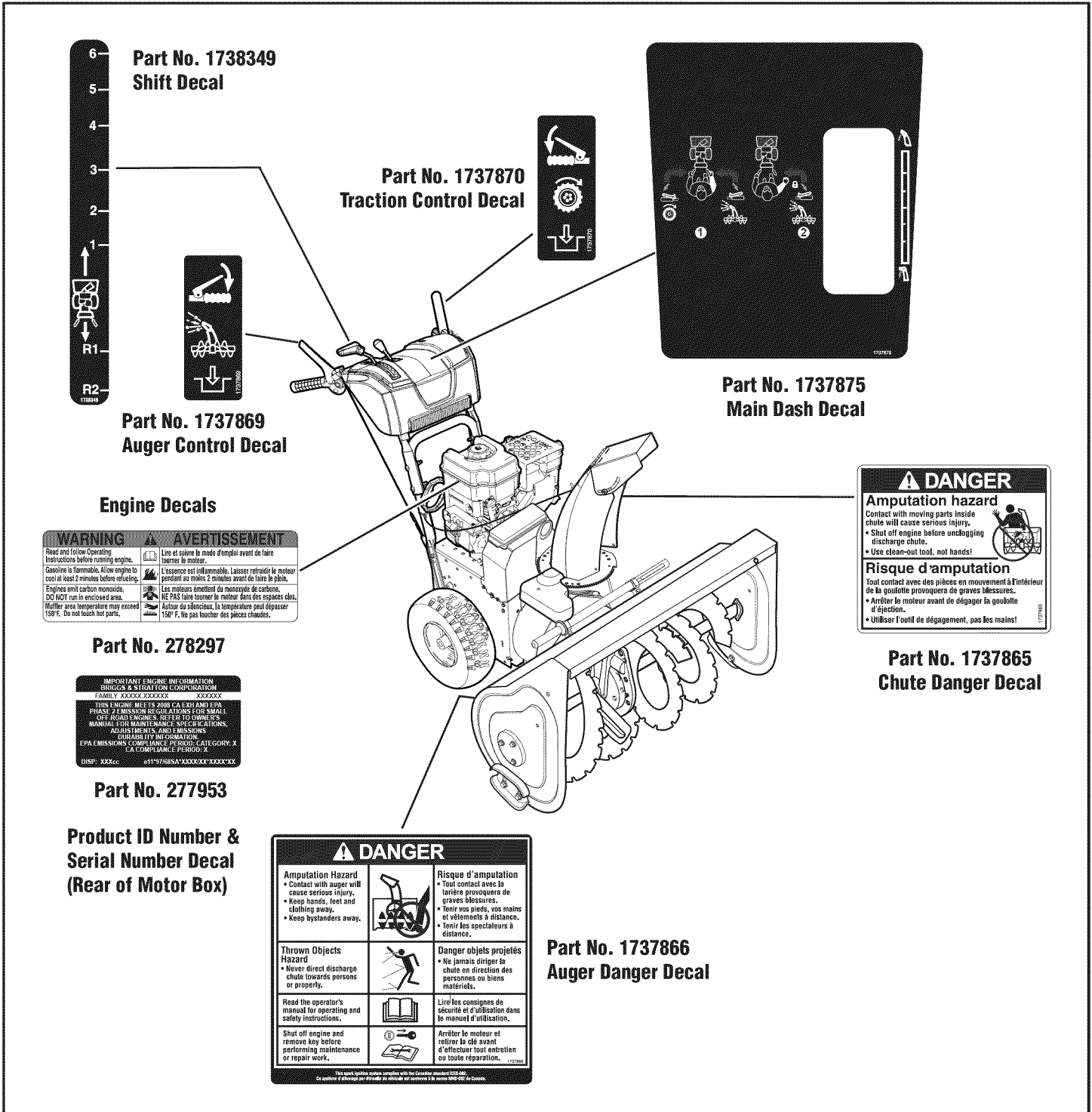

**Part No. 1738349  
Shift Decal**

**Part No. 1737870  
Traction Control Decal**

**Part No. 1737875  
Main Dash Decal**

**Part No. 1737869  
Auger Control Decal**

**Engine Decals**

<b>WARNING</b> Read and follow Operating Instructions before running engine. Gasoline is flammable. Allow engine to cool at least 2 minutes before refueling. Engines emit carbon monoxide. DO NOT run in enclosed area. Muffler area temperature may exceed 150° F. Do not touch hot parts.	<b>AVERTISSEMENT</b> Lire et suivre le mode d'emploi avant de faire tourner le moteur. L'essence est inflammable. Laisser refroidir le moteur pendant au moins 2 minutes avant de faire le plein. Les moteurs émettent du monoxyde de carbone. NE PAS faire tourner le moteur dans des espaces clos. Autour du silencieux, la température peut dépasser 150° F. Ne pas toucher des pièces chaudes.
--	--

**Part No. 278297**

**IMPORTANT ENGINE INFORMATION  
BROGGS & STRATTON CORPORATION**  
FAMILY XXXXX, XXXXXX XXXXXX  
THIS ENGINE MEETS 2008 CA EXH AND EPA BRINE & FERTILIZER REGULATIONS FOR SMALL OFF ROAD ENGINES. REFER TO OWNERS' MANUAL FOR MAINTENANCE SPECIFICATIONS, ADJUSTMENTS, AND EMISSIONS DIRECTION INFORMATION  
EPA EMISSIONS COMPLIANCE PERIOD: CATEGORY X  
CA COMPLIANCE PERIOD: X  
DISP: XXXcc #11797865X1XXXXXXXXXXXX

**Part No. 277953**

**Product ID Number & Serial Number Decal (Rear of Motor Box)**

**DANGER**

<b>Amputation Hazard</b> • Contact with auger will cause serious injury. • Keep hands, feet and clothing away. • Keep bystanders away.		<b>Risque d'amputation</b> • Tout contact avec la tarière provoquera de graves blessures. • Tenir vos pieds, vos mains et vêtements à distance. • Tenir les spectateurs à distance.
<b>Thrown Objects Hazard</b> • Never direct discharge chute towards persons or property.		<b>Danger objets projetés</b> • Ne jamais diriger la chute en direction des personnes ou biens matériels.
<b>Read the operator's manual for operating and safety instructions.</b>		<b>Lire les consignes de sécurité et d'utilisation dans le manuel d'utilisation.</b>
<b>Shut off engine and remove key before performing maintenance or repair work.</b>		<b>Arrêter le moteur et retirer la clé avant d'effectuer tout entretien ou toute réparation.</b>

This spark system system complies with the Canadian standard CS24-002. Ce système d'allumage est conforme au standard de sécurité à la norme SMOE 022 du Canada.

**Part No. 1737866  
Auger Danger Decal**

**DANGER**

**Amputation hazard**  
Contact with moving parts inside chute will cause serious injury.  
• Shut off engine before unclogging discharge chute.  
• Use clean-out tool, not hands!

**Risque d'amputation**  
Tout contact avec des pièces en mouvement à l'intérieur de la goulotte provoquera de graves blessures.  
• Arrêter le moteur avant de dégager la goulotte d'éjection.  
• Utiliser l'outil de dégagement, pas les mains!

**Part No. 1737865  
Chute Danger Decal**

## FEATURES AND CONTROLS

**NOTICE:** Read this OPERATOR'S MANUAL and OPERATOR SAFETY before operating your snow thrower. Compare the illustrations with your SNOW THROWER to familiarize yourself with the location of various controls and adjustments. Save this manual for future reference.

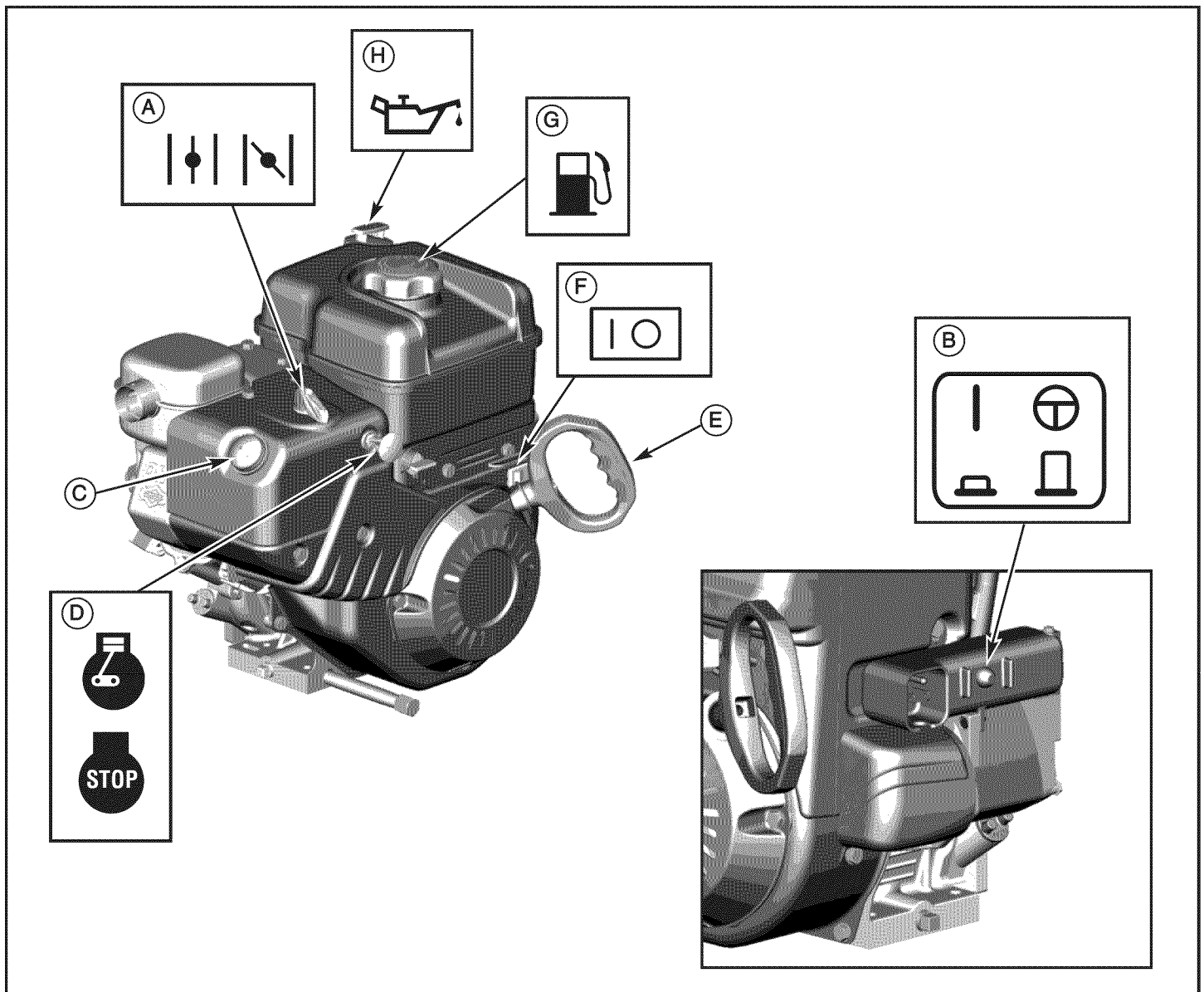

Engine Controls

Figure 2

### ENGINE AND SNOW THROWER CONTROLS

#### ENGINE CONTROLS

- A. Choke Control Knob** — Used to start a cold engine (see Figure 2).
- B. Electric Start Button** — Used to start the engine using the electric starter.
- C. Primer Button** — Used to inject fuel directly into the carburetor manifold to ensure fast starts in cool weather.
- D. Safety Key** — Must be inserted to start engine. Pull out to stop. Do not turn safety key.
- E. Starter Cord Handle** — Used to start the engine manually.
- F. ON/OFF Switch** — Used to start and stop the engine.

- G. Fuel Tank and Cap** — Fill the fuel tank to approximately 1-1/2 in. (38 mm) below the top of the neck to allow for fuel expansion.

- H. Oil Fill Cap (Extended Dipstick)**

#### SNOW THROWER CONTROLS

- A. Speed Select Lever** — Allows the operator to use one of six (6) forward and two (2) reverse speeds (see Figure 3). To shift, move speed select lever to desired position.

**NOTICE:** Do not move speed select lever while Traction Control is engaged. This may result in severe damage to the drive system.

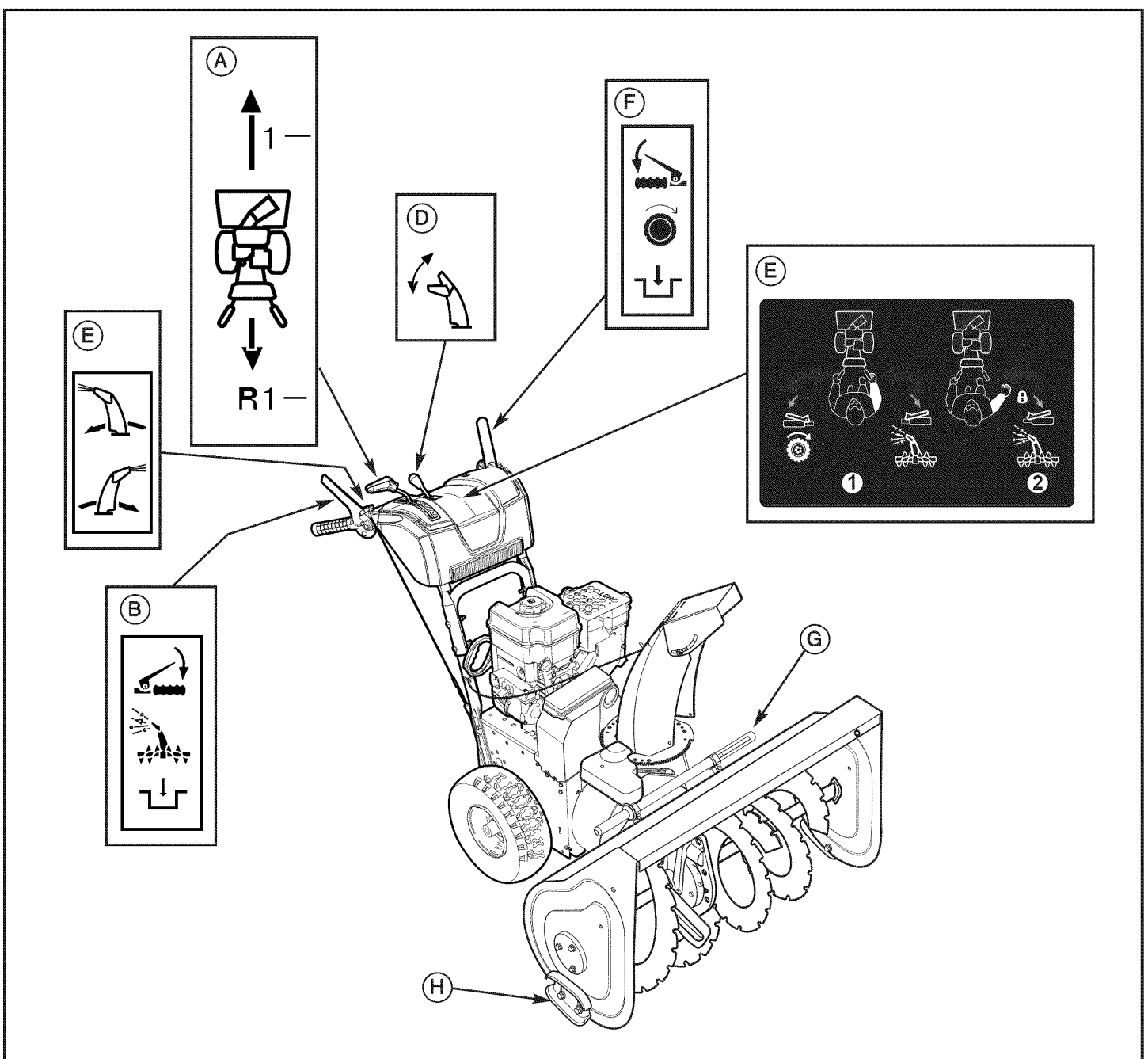

Snow Thrower Controls

**Figure 3**

- B. Auger Control Lever** — Used to engage and disengage the auger and impeller. To engage push down, to disengage release.
- C. Chute Rotation Switch** — Used to rotate the discharge chute to the left or right.
- D. Deflector Control Lever** — Used to control the angle of the chute deflector (up or down).
- E. Free-Hand™ Control** — After engaging the traction control (left hand) and auger control (right hand), allows the operator to release the auger control lever to use the other controls.
- F. Traction Control Lever** — Used to propel snow thrower forward or reverse. Push down to engage, release to disengage.
- G. Clean-Out Tool** — Used to remove snow and debris from the discharge chute and the auger housing.
- H. Skid Shoe** — Used to adjust the ground clearance of the auger housing.

# OPERATION

## BEFORE OPERATING SNOW THROWER

- Check the fasteners. Make sure all fasteners are tight.
- On electric start models, the unit was shipped with the starter cord plugged into the engine. Before operating, unplug the starter cord from the engine.

**NOTE:** This snow thrower was shipped WITH OIL in the engine. See “Before Starting Engine” instructions in the OPERATION section of this manual before starting engine.



**WARNING:** The operation of any snow thrower can result in foreign objects being thrown into the eyes, which can result in severe eye damage. Always wear safety glasses or eye shields before beginning snow thrower operation. We recommend standard safety glasses or Wide Vision Safety Mask over spectacles.

## OPERATE THE SNOW THROWER



**CAUTION:** Operation with a Snow Cab. Wind may blow exhaust gasses back towards the operator. If you notice the smell of exhaust, change direction of operation.

**NOTICE:** Do not throw snow toward a building as hidden objects could be thrown with sufficient force to cause damage.

1. Start the engine. See “To Start Engine” in this section.
2. Press the chute rotation switch (A, Figure 4) to the UP/DOWN position to rotate the discharge chute left or right. See “Discharge Chute and Deflector” in this section.
3. Push the deflector control lever (B) forward or pull back to control the angle of the chute deflector. See “Discharge Chute and Deflector” in this section.



**CAUTION:** Before operating, make sure the area in front of the snow thrower is clear of bystanders or obstacles.

4. Fully press and hold the auger control lever (C) to engage auger rotation. Releasing the auger control lever will disengage the auger - unless the Free-Hand™ control has been activated.
5. Fully press and hold the traction and Free-Hand™ control lever (D) to engage the traction drive and begin moving the snow thrower. To disengage the traction drive, completely release the lever.
6. When BOTH levers are depressed, the Free-Hand™ control is activated. This allows auger control lever to be released - YET AUGER ROTATION WILL CONTINUE - until the Free-Hand™ control is released.

**NOTE:** Always release the traction control lever before moving the speed select lever.

7. Use the speed select lever (E) to select the forward drive speed. Set the speed select lever to one of the following positions as determined by snow conditions:
  - 1-2 Wet, Heavy, Slushy, Extra Deep
  - 3 Moderate
  - 4-5 Very Light
  - 6 Transport

**NOTE:** When clearing wet, heavy, snow, it is recommended that the ground speed of the unit be reduced, maintained full throttle and do not attempt to clear the full width of the unit.

8. To stop moving forward, release the traction control lever (D).
9. To move the snow thrower backwards, move the speed select lever into either first or second reverse position and engage the traction control lever.

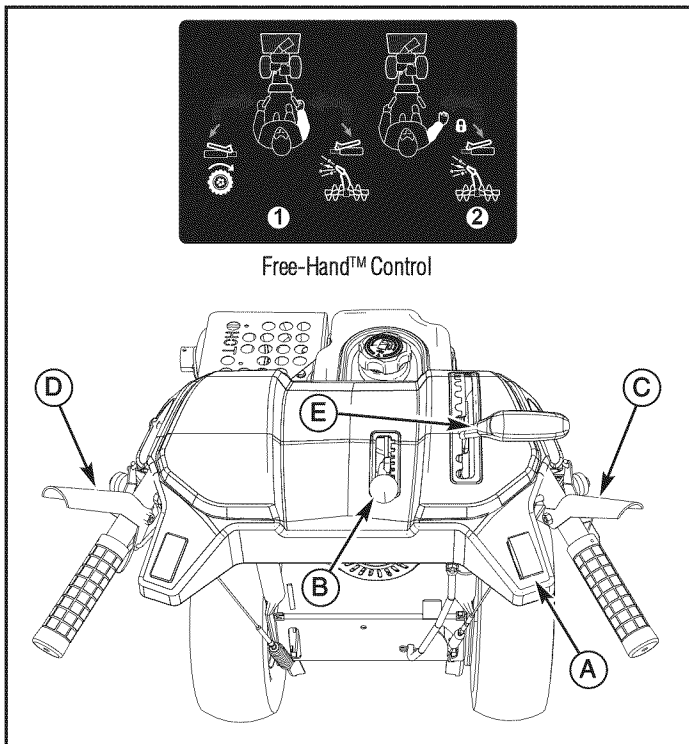

Control Levers

Figure 4

## STOP THE SNOW THROWER

1. Release the auger control lever (C, Figure 4).
2. Release the traction control lever (D).
3. Push the ON/OFF switch (A, Figure 12) to the OFF position and pull out the safety key (B).

**WARNING:** Never run engine indoors or in an enclosed, poor ventilated area. Engine exhaust contains **CARBON MONOXIDE**, an **ODORLESS** and **DEADLY GAS**.

- Keep hands, feet, hair, and loose clothing away from any moving parts on engine and snow thrower.
- Temperature of muffler and nearby areas can exceed 150°F (66°C). Avoid these areas.
- **DO NOT** allow children or young teenagers to operate or be near snow thrower while it is operating.

**WARNING:** Read Operator's Manual before operating machine. This machine can be dangerous if used carelessly.

- Never operate the snow thrower without all guards, covers, shields in place.
- Never direct discharge towards windows or allow bystanders near machine while engine is running.
- Stop the engine whenever leaving the operating position.
- Disconnect spark plug before unclogging the impeller housing or the discharge chute and before making repairs or adjustments.
- When leaving the machine, remove the safety key. To reduce the risk of fire, keep the machine clean and free from spilled gas, oil, and debris.

## TRACTION LOCK PINS

The right traction wheel can be completely released using the locking pin (A, Figure 5). This allows the unit to be easily moved with the engine off.

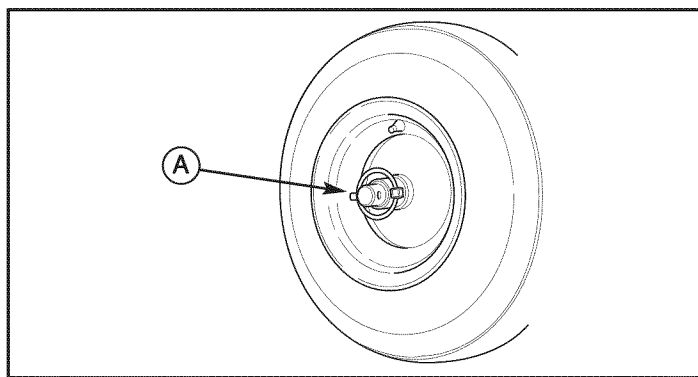

Traction Lock Pins

Figure 5

## DISCHARGE CHUTE AND DEFLECTOR

### Discharge Chute Rotation (Left/Right)

1. Press the chute rotation switch to the UP position and hold to rotate the chute to the left (A, Figure 6).
2. After the desired position is obtained, release the switch to the CENTER position to turn off.
3. Press the switch to the DOWN position and hold to rotate clockwise.

### Chute Deflector (Up/Down)

1. Push the deflector control lever FORWARD to provide a higher stream and greater distance (B, Figure 6).
2. Pull the deflector control lever BACK to provide a lower stream and less distance.

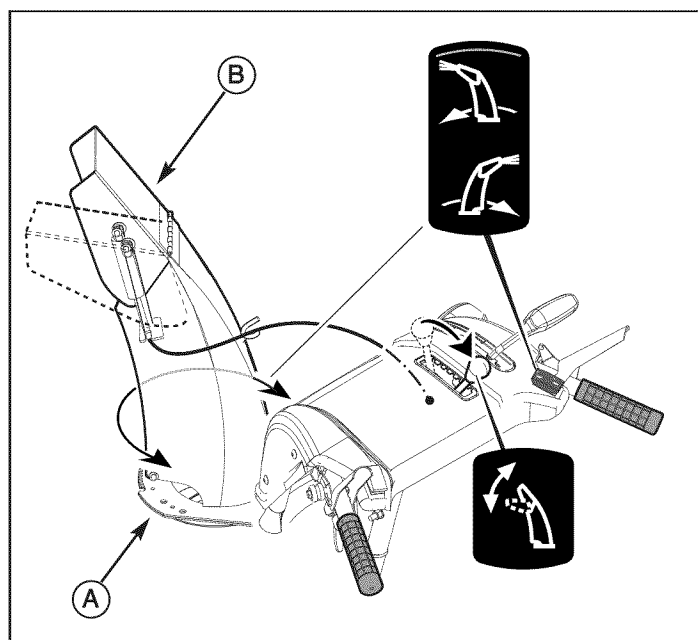

Discharge Chute and Deflector

Figure 6

## OPERATION

### CHECK THE OIL (BEFORE STARTING ENGINE)

**NOTE:** The engine was shipped from the factory filled with oil. Check the level of the oil. Add oil as needed.

1. Make sure the unit is level. Use a high quality detergent oil classified "For Service SG, SH, SJ, SL, or higher".
2. Remove the oil fill cap/dipstick (A, Figure 7) and wipe with a clean cloth.
3. Insert the oil fill cap/dipstick and turn clockwise to tighten.
4. Remove the oil fill cap/dipstick and check the oil.

**NOTE:** Do not check the level of the oil while the engine runs.

5. If necessary, add oil until the oil reaches the FULL mark on the oil fill cap/dipstick. Do not add too much oil.
6. Tighten the oil fill cap/dipstick securely each time you check the oil level.

**NOTE:** Synthetic 5W30 motor oil is acceptable for all temperatures. DO NOT mix oil with gasoline. See Chart for oil recommendations.

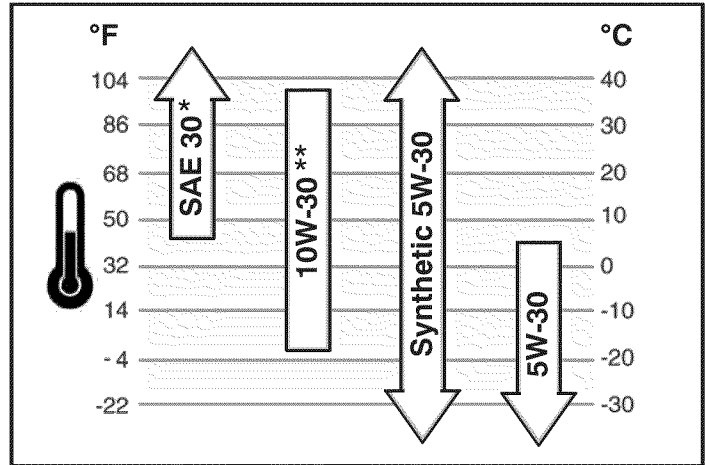

\* Below 40°F (4°C) the use of SAE 30 will result in hard starting.

\*\* Above 80°F (27°C) the use of 10W-30 may cause increased oil consumption. Check oil level more frequently.

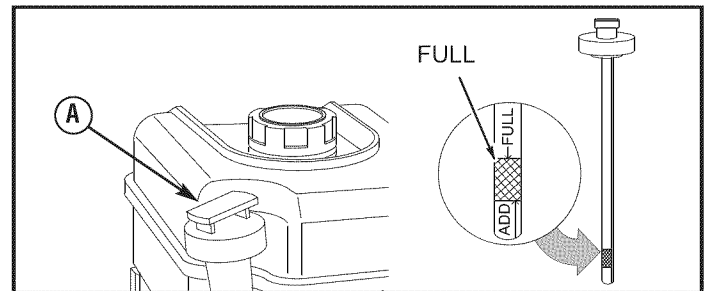

Checking the Oil

Figure 7

### FILL THE FUEL TANK

This engine is certified to operate on gasoline. Exhaust Emission Control System: EM (Engine Modifications).

Fill the fuel tank with fresh, clean, unleaded regular, unleaded premium, or reformulated automotive gasoline with a minimum of 85 octane along with a fuel stabilizer (follow instructions on fuel stabilizer package). DO NOT use leaded gasoline. We recommend that fuel stabilizer be added to the fuel each time that gasoline is added to the fuel tank.

**NOTE:** Winter grade gasoline has higher volatility to improve starting. Be certain container is clean and free from rust or other foreign particles. Never use gasoline that may be stale from long periods of storage in the container.

**CAUTION:** DO NOT use gasoline containing any amount of alcohol as it can cause serious damage to the engine or significantly reduce the performance.

**WARNING:** Gasoline is flammable. Always use caution when handling or storing gasoline. Turn engine off and let engine cool at least two minutes before removing the gas cap. Do not add gasoline to the fuel tank while snow thrower is running, hot, or when snow thrower is in an enclosed area. Keep away from open flame, electrical sparks and DO NOT SMOKE while filling the fuel tank. Never fill the fuel tank completely; but fill the fuel tank to within 1-1/2 inches (3.8 mm) from the top to provide space for the expansion of the fuel. Always fill fuel tank outdoors and use a funnel or spout to prevent spilling. Make sure to wipe up any spilled fuel before starting the engine.

Store gasoline in a clean, approved container, and keep the cap in place on the container. Keep gasoline in a cool well ventilated place; never in the house. Never buy more than a 30 day supply of gasoline to assure volatility. Gasoline is intended to be used as a fuel for internal combustion engines; therefore, do not use gasoline for any other purpose. Since many children like the smell of gasoline, keep it out of their reach because the fumes are dangerous to inhale, as well as being explosive.

**START THE ENGINE**

Be sure that engine oil is at FULL mark on the oil fill cap/dipstick. The snow thrower engine is equipped with an A.C. electric starter and recoil starter. Before starting the engine, be certain that you have read the following information.

If engine floods, set the choke to the OPEN/RUN position and crank until the engine starts.

**! WARNING:** The electric starter is equipped with a three-wire power cord and plug designed to operate on AC house hold current. The power cord must be properly grounded at all times to avoid the possibility of electric shock which can cause injury to the operator. Follow all instructions carefully as set forth:

Make sure your house has a three-wire grounded system.

If you are not sure, ask a licensed electrician. If your house does not have a three-wire grounded system, do not use this electric starter under any condition.

If your house has a three-wire grounded system but a three-hole receptacle is not available to connect the electric starter, have a three-hole receptacle installed by a licensed electrician.

**! WARNING:** To connect power cord, always connect the power cord first to the switch box located on the engine and then plug the other end into a three-hole grounded receptacle.

**! WARNING:** To disconnect the power cord, always unplug the end connected to the three-hole grounded receptacle first.

**Start the engine as follows:**

1. Check the oil level. See the "Check/Add Oil" section in the ENGINE MANUAL.
2. Make sure equipment drive controls are disengaged.
3. Push the ON /OFF switch (A, Figure 8) to the ON position.

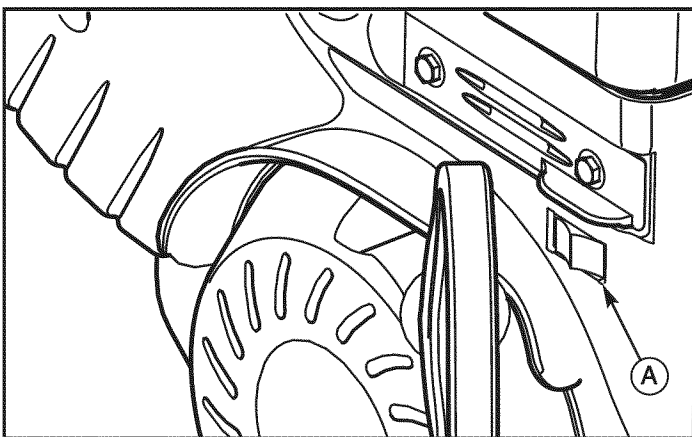

Starting the Engine

**Figure 8**

4. Insert the safety key (A, Figure 9) into the safety key slot and push fully in to the RUN position.
5. Turn the choke knob (B) fully clockwise if engine is cold.

**NOTE:** Do not use the choke to start a warm engine.

6. Push the primer button (C) two times.

**NOTE:** Do not use the primer to start a warm engine.

**NOTE:** Ensure that electric extension cord is removed from the power receptacle.

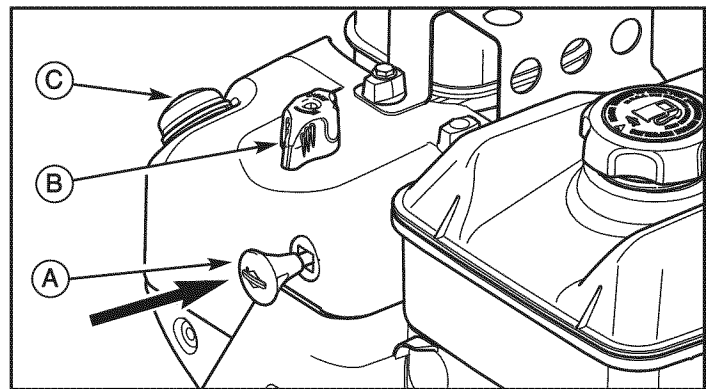

Inserting Safety Key

**Figure 9**

7. **Rewind Start:** Firmly hold the starter cord handle (A, Figure 10). Pull the starter cord handle slowly until resistance is felt, then pull rapidly.

**! WARNING:** Rapid retraction of the starter cord (kickback) will pull your hand and arm toward the engine faster than you can let go. Broken bones, fractures, bruises, or sprains could result. When starting engine, pull the starter cord slowly until resistance is felt and then pull rapidly to avoid kickback.

**NOTE:** If the engine does not start after three attempts, see the Engine Manual Troubleshooting section.

8. **Electric Start:** First connect the extension cord to the power cord receptacle and then into a wall receptacle. If additional extension cord is required, make sure it is three-wire.

**! WARNING:** If the extension cord is damaged, it must be replaced by the manufacturer (or its service agent) or a similarly qualified person to avoid a hazard.

## OPERATION

9. **Electric Start:** Depress the starter push button (A, Figure 11). After you start the engine, first disconnect the extension cord from the wall receptacle and then from the power cord receptacle (B).

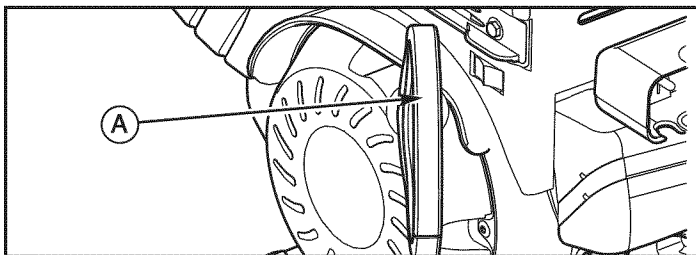

Starting with Cord Handle

Figure 10

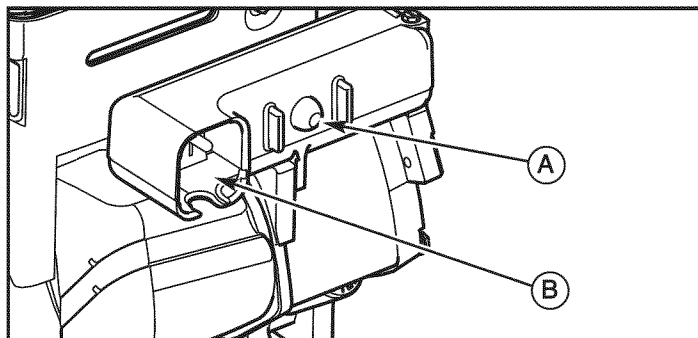

Starting with Electric Start

Figure 11

**IMPORTANT:** To extend the life of the starter, use short starting cycles (five seconds maximum). Wait one minute between starting cycles.

**NOTE:** If the engine does not start after three attempts, see the Engine Manual Troubleshooting section.

## STOP THE ENGINE

Before stopping the engine for a few minutes to help dry off any moisture on the engine.

**WARNING:** Gasoline and vapors are extremely flammable and explosive. Fire or explosion can cause severe burns or death. DO NOT choke the carburetor to stop the engine.

1. Push the ON/OFF switch (A, Figure 12) to the OFF position.
2. Remove the safety key (B). Keep the safety key out of the reach of children.

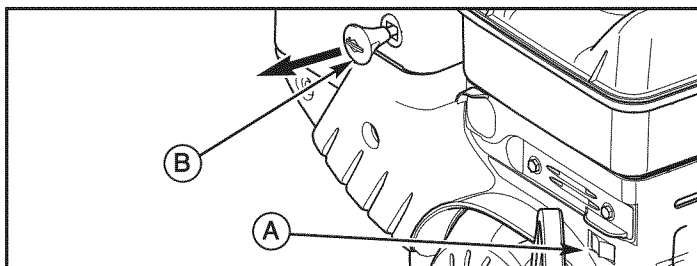

Stopping the Engine

Figure 12



**CLEAR A CLOGGED DISCHARGE CHUTE**

**! DANGER: Hand contact with the rotating impeller inside the discharge chute is the most common cause of injury associated with snow throwers. Never clear or unclog discharge chute with your hands, or while engine is running. Fingers can quickly become caught and traumatic amputation or severe laceration can result.**

- SHUT OFF THE ENGINE!
- Wait 10 seconds to be sure that the impeller blades have stopped rotating.
- Always use a clean-out tool, not your hands.

A clean-out tool (A, Figure 13) is attached to either the handle or the top of the auger housing. Use the clean-out tool to remove snow from the auger housing.

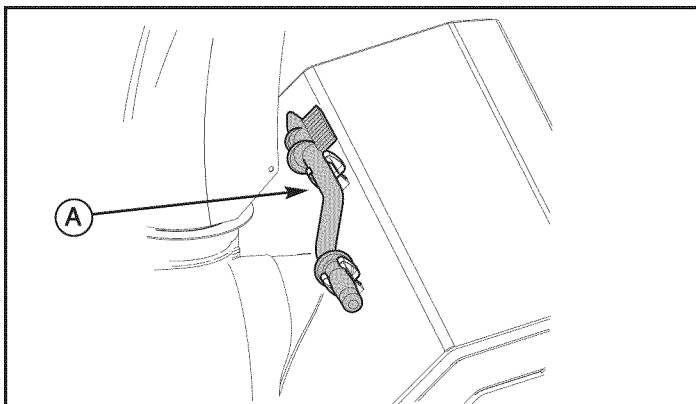

Clean-Out Tool

**Figure 13**

**OPERATING TIPS**

1. Most efficient snowthrowing is accomplished when snow is removed immediately after it falls.
2. For complete snow removal, slightly overlap each swath previously taken.
3. Snow should be discharged downwind whenever possible.
4. For normal usage, set the skids 1/8 inch (3 mm) below the scraper bar. For extremely hard-packed snow surfaces, the skids may be adjusted upward to ensure cleaning efficiency.
5. On gravel or crushed rock surfaces, the skids should be set at 1-1/4 inch (32 mm) below the scraper bar (see "Adjust Skid Height" in the MAINTENANCE section of this manual). Rocks and gravel must not be picked up and thrown by the machine.
6. After the snowthrowing job has been completed, allow the engine to idle for a few minutes, to melt snow and ice accumulated on the engine.
7. Clean the snow thrower thoroughly after each use.
8. Remove ice and snow accumulation and all debris from the entire snow thrower, and flush with water (if possible) to remove all salt or other chemicals. Wipe snow thrower dry.
9. Before starting snow thrower, always inspect augers and impeller for ice accumulation and/or debris, which could result in snow thrower damage.
10. Check oil level before every start. Make sure the oil is at the FULL mark on the oil fill cap/dipstick.

# MAINTENANCE

SERVICE RECOMMENDATIONS									
PROCEDURE		FIRST 2 HOURS	BEFORE EACH USE	AFTER EACH USE	EVERY 5 HOURS	EVERY 10 HOURS	EVERY 25 HOURS	BEGINNING EACH SEASON	BEFORE STORAGE
SAFETY	Check to Make Sure Auger Blade Stops Within 5 Seconds After Right Control Lever is Released		✓						
	Lubricate Control Levers and Linkages	✓				✓		✓	
SNOW THROWER	Check Snow Thrower for Loose Hardware				✓			✓	
	Lubricate Hex Shaft and Chains							✓	✓
	Lubricate Auger Shaft Fittings					✓			✓
	Lubricate Chute Rotation Gear and Deflector Mechanism						✓		
	Remove All Snow and Slush off Snow Thrower to Prevent Freezing of Auger or Controls			✓					
	Check Tire Pressure						✓		
ENGINE	Oil, Check		✓		✓			✓	
	Oil, Change	✓					✓	✓	
	Check and Replace Spark Plug							✓	

**NOTE: The warranty on this snow thrower does not cover items that have been subjected to operator abuse or negligence. To receive full value from the warranty, operator must maintain snow thrower as instructed in this manual.**

The above **Service Recommendations** are supplied to assist the operator to properly maintain the snow thrower.

### LUBRICATE AUGER GEAR BOX

The auger gear box is lubricated at the factory and should not require additional lubrication. If for some reason the lubricant should leak out, or if the auger gear box has been serviced, add Lubriplate GR132 Grease or equivalent. Maximum 3-1/4 ounces, (92 grams) should be used.

Remove filler plug (A, Figure 14), once a year. If grease is visible, do not add. If grease is not visible, use a piece of fine wire, like a dipstick to check if there is grease in the gear box. Mobilux EP1 and Shell Alvania EP1 are suitable equivalents.

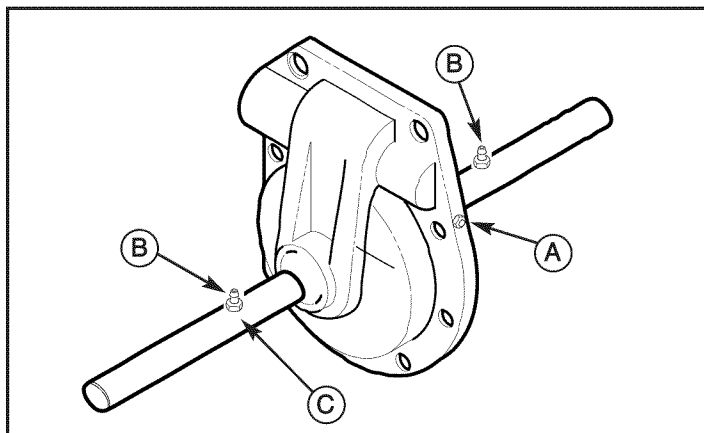

Lubricating Auger Gear Box

**Figure 14**

### LUBRICATE AUGER SHAFT FITTINGS

1. Using a hand grease gun, lubricate the auger shaft fittings (B, Figure 14) every ten (10) operating hours. Each time a shear pin is replaced, the auger shaft (C) MUST be greased. (See "Auger Shear Pin Replacement" section.)
2. For storage or when replacing shear pins, remove shear pins and lubricate auger shaft fittings (B). Rotate augers several times on the shaft and reinstall the shear pins.

### LUBRICATE CONTROL LEVER LINKAGE

Check the function of the Free-Hand controls. The controls should function as described in the OPERATION section.

**WARNING:** It is critical for the safe operation of the unit that the controls disengage when released.

Lubricate the linkage for the traction/Free-Hand control (A, Figure 15), speed select control (B), and auger control (C) every ten (10) operating hours, or as necessary to ensure safe operation.

**NOTICE:** Under no circumstances should the unit be used if the controls do not function properly.

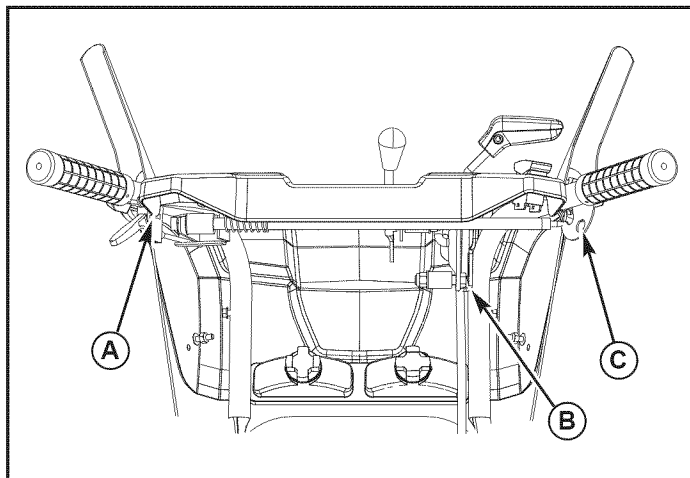

Lubricating Control Lever Linkage

**Figure 15**

### LUBRICATE DISCHARGE CHUTE AND DEFLECTOR

Lubricate the chute rotation gear (A, Figure 16) and deflector hinge (B) with automotive type oil every twenty-five (25) operating hours.

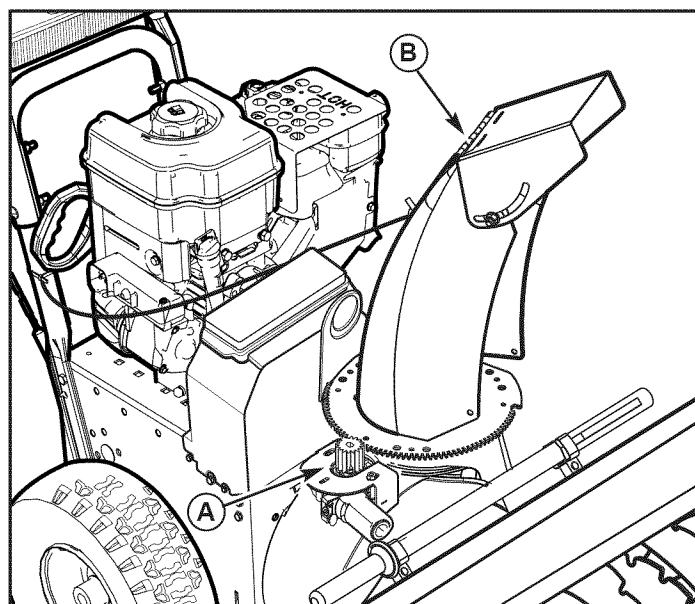

Lubricating Discharge Chute and Deflector

**Figure 16**

# MAINTENANCE

## ENGINE MAINTENANCE

**Check Crankcase Oil Level** - Before starting engine and after each 8 hours of continuous use. Add the recommended motor oil as required.

**NOTE: Over filling the engine can affect performance. Tighten the oil fill cap securely to prevent leakage.**

**Change Oil** - Every 50 hours of operation or at least once a year, even if the snow thrower is not used for fifty hours. Use a clean, high quality detergent oil. Fill the crankcase to FULL line on dipstick (A, Figure 17). Be sure original container is marked: A.P.I. service "SF" or higher. Do not use SAE10W40 oil (as it may not provide proper lubrication). **See Chart for oil recommendations.**

**Drain Oil** - Position snow thrower so that the oil drain plug (A, Figure 18) is lowest point on engine. When the engine is warm, remove oil drain plug and oil fill cap and drain oil into a suitable container.

Replace oil drain plug and tighten securely. Refill crankcase with the recommended motor oil.

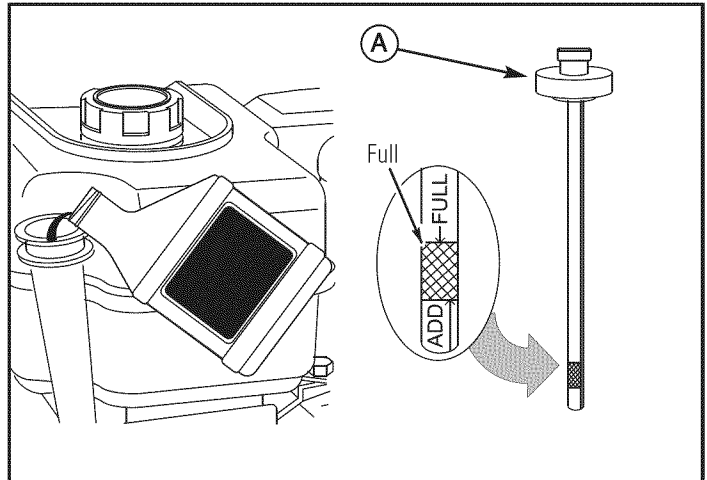

Checking Crankcase Oil Level

Figure 17

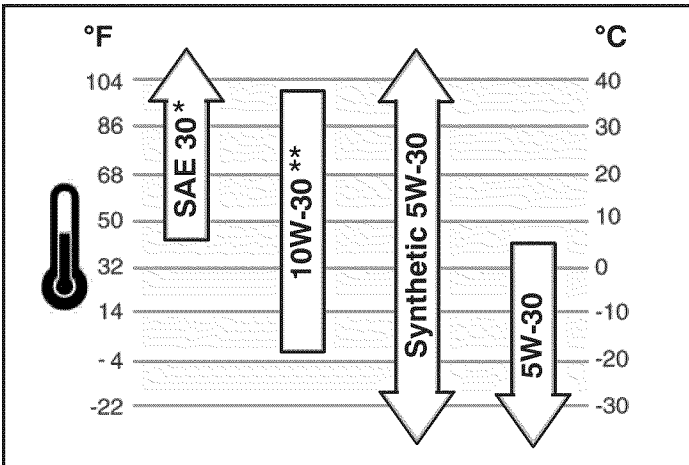

Oil Drain Plug

Figure 18

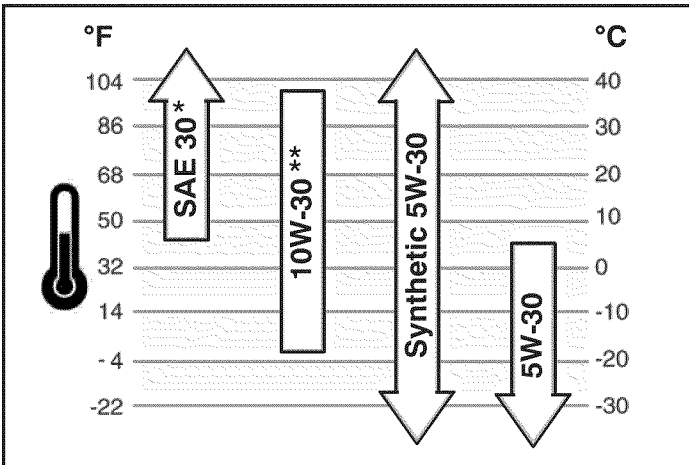

\* Below 40°F (4°C) the use of SAE 30 will result in hard starting.  
 \*\* Above 80°F (27°C) the use of 10W-30 may cause increased oil consumption. Check oil level more frequently.

**CHANGE THE SPARK PLUG**

**Remove the Snow Hood**

1. Remove the choke control knob (A, Figure 19).
2. Remove the safety key (B).
3. Remove the mounting screws (A, Figure 20).
4. Slowly remove the snow hood (B) Make sure that the primer button hose (C) and the ignition wire (D) are not disconnected.
5. The spark plug (E) can now be accessed.
6. To install the snow hood, first make sure that the primer button hose and the ignition wire are connected.
7. Mount the snow hood to the engine and secure with the mounting screws.
8. Connect the choke control knob (A, Figure 21) with the choke shaft on the carburetor (B). Make sure the choke control knob is properly installed. If the choke control knob is not installed correctly, the choke will not operate.
9. Install the safety key (C).

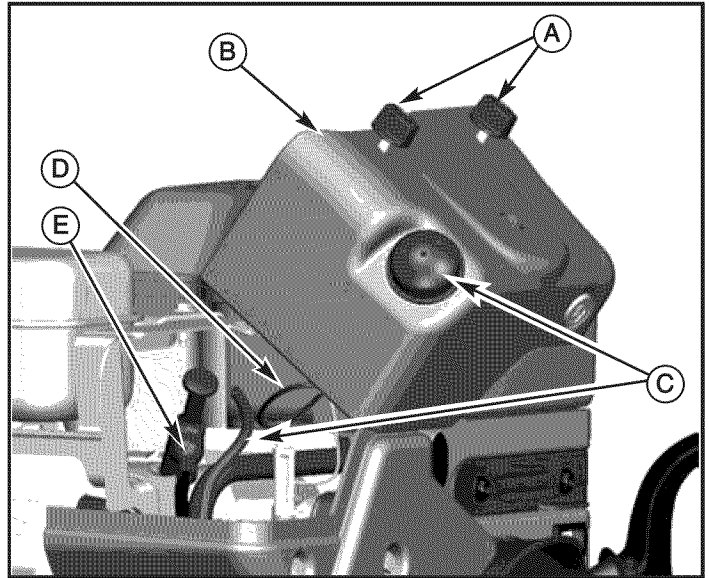

Removing the Snow Hood

**Figure 20**

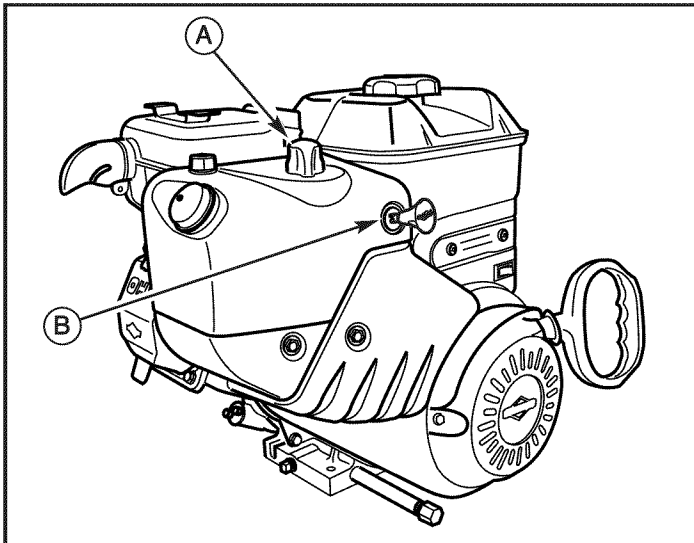

Snow Thrower Engine

**Figure 19**

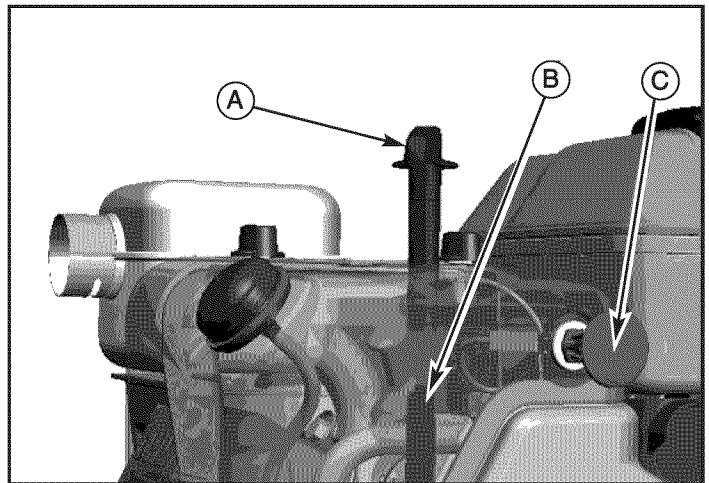

Connecting Choke Control Knob

**Figure 21**

## MAINTENANCE

### Check and Replace Spark Plug

Check the spark plug every twenty-five (25) hours. Replace the spark plug (Figure 22) if the electrodes are pitted or burned or if the porcelain is cracked.

1. Remove snow hood (see "Remove the Snow Hood" section).
2. Clean spark plug and reset gap periodically.
3. Clean area around spark plug base before removal, to prevent dirt from entering engine.
4. Replace spark plug if electrodes are pitted or burned or if porcelain is cracked.
5. Clean spark plug by carefully scraping electrodes (do not sandblast or use wire brush).
6. Be sure spark plug is clean and free of foreign material. Check electrodes gap with a wire feeler gauge and reset gap to 0.030" (0.76 mm) if necessary.
7. Before installing spark plug, coat threads lightly with graphite grease to insure easy removal.
8. Tighten plug firmly into engine. If torque wrench is available, tighten plug to 18-23 ft-lbs (24.4-31.2 Nm).

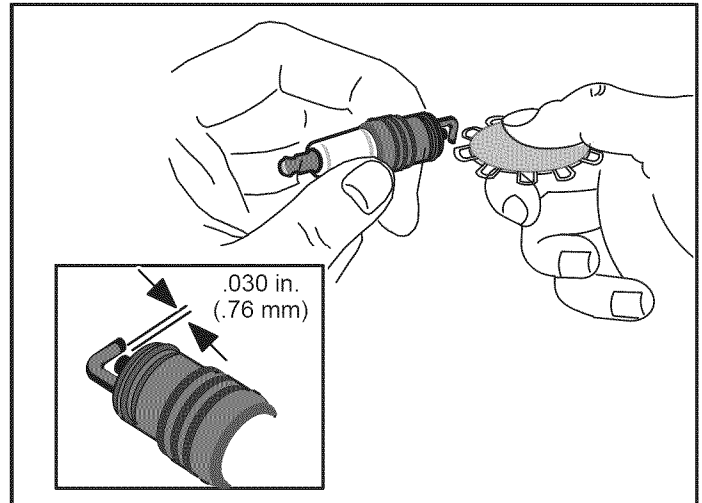

Replacing Spark Plug

Figure 22

**WARNING:** Always turn unit off, remove ignition key, and disconnect the spark plug wire before making any repairs or adjustments.

### ADJUST SKID HEIGHT

This snow thrower is equipped with two height adjust skids, secured to the outside of the auger housing. These elevate the front of the snow thrower.

When removing snow from a hard surface area such as a paved driveway or walk, adjust the skids up to bring the front of the snow thrower down.

When removing snow from rock or uneven construction, raise the front of the snow thrower by moving the skids down. This will help to prevent rocks and other debris from being picked up and thrown by the augers.

#### To adjust skids, proceed as follows:

1. Place a block (equal to height from ground desired) under scraper bar near but not under skid.
2. Loosen skid mounting nuts (A, Figure 23) and push the skid down (B) until it touches the ground. Retighten mounting nuts.
3. Set skid on other side at same height.

**NOTE:** Make sure that snow thrower is set at same height on both sides.

**WARNING:** Be certain to maintain proper ground clearance for your particular area to be cleared. Objects such as gravel, rocks, or other debris, if struck by the impeller, may be thrown with sufficient force to cause personal injury, property damage, or damage to the snow thrower.

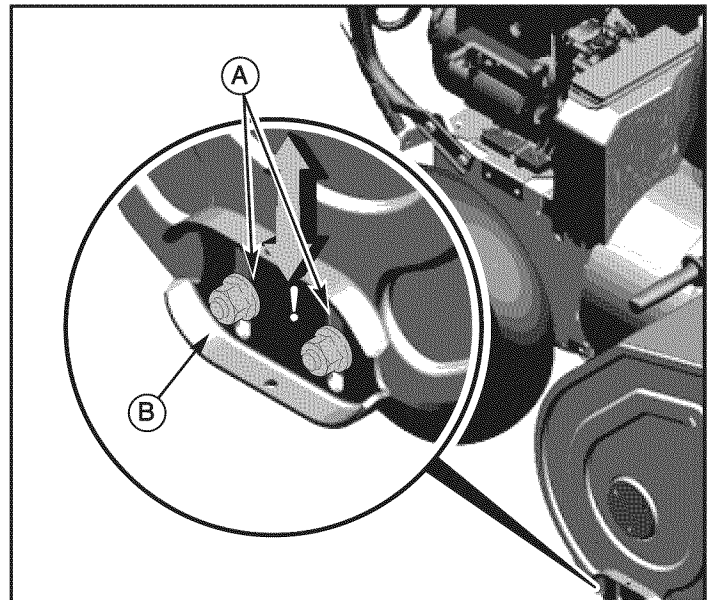

Adjusting Skid Height

Figure 23

## BELT ADJUSTMENT

### Traction Drive Belt

The traction drive belt has constant spring pressure and does not require an adjustment. If the traction drive belt is slipping, replace the belt. See authorized dealer.

### Auger Drive Belt

If your snow thrower will not discharge snow, check the control cable adjustment. If it is correct, then check the condition of the auger drive belt. If it is damaged or loose, replace it (see authorized dealer).

1. Disconnect spark plug wire.
2. Remove screw (A, Figure 24) from belt cover (B). Remove belt cover.
3. Loosen nut on idler drive pulley (A, Figure 25) and move idler drive pulley towards belt about 1/8 inch (3 mm).



**WARNING: Do not over-tighten, as this may lift the lever and cause the auger drive to be engaged without depressing the auger control.**

4. Tighten nut.
5. With the aid of an assistant, engage the auger drive clutch. Check tension on belt which is opposite idler pulley (B, Figure 25). Belt should deflect about 1/2 inch (12.5 mm) with moderate pressure. You may have to move idler pulley more than once to obtain the correct tension.
6. Release the auger drive control lever. **The auger must stop within 5 seconds.**
7. If auger does not operate properly, stop engine and recheck drive linkage adjustments.
8. Reinstall belt cover (B, Figure 24). Tighten screw (A).
9. Whenever belts are adjusted or replaced, the cables will need to be adjusted (see "Check and Adjust the Cables" section).
10. Attach the spark plug wire.

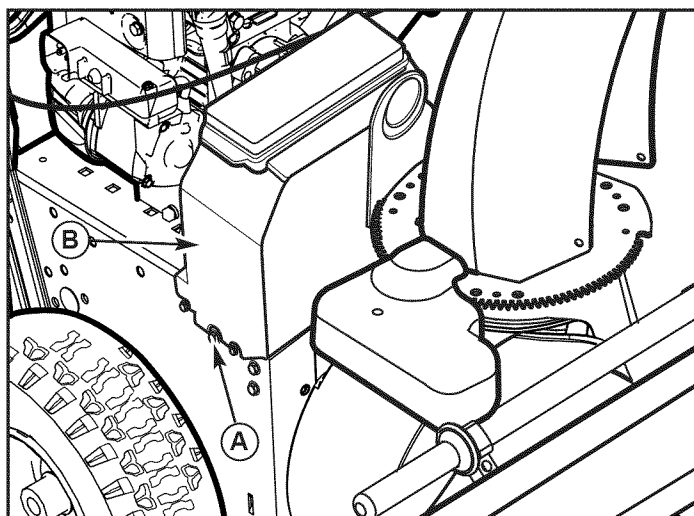

Adjusting Auger Drive Belt

Figure 24

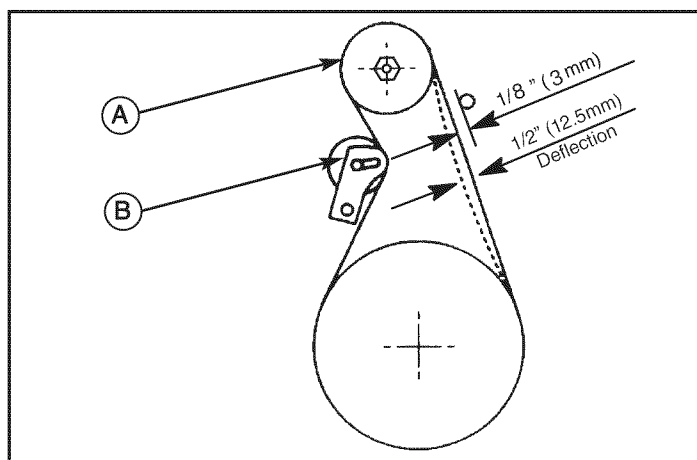

Checking Tension on Auger Drive Belt

Figure 25

## BELT GUIDE ADJUSTMENT

1. Remove spark plug wire.
2. Have someone engage the auger drive. This will engage auger idler pulley (A, Figure 26).
3. Measure the distance between the belt guide (B) and belt (C). The distance should be about 1/8 inch (3 mm).
4. If adjustment is necessary, loosen belt guide mounting bolt. Move belt guide to the correct position. Tighten mounting bolt.
5. Install belt cover.
6. Connect spark plug wire.

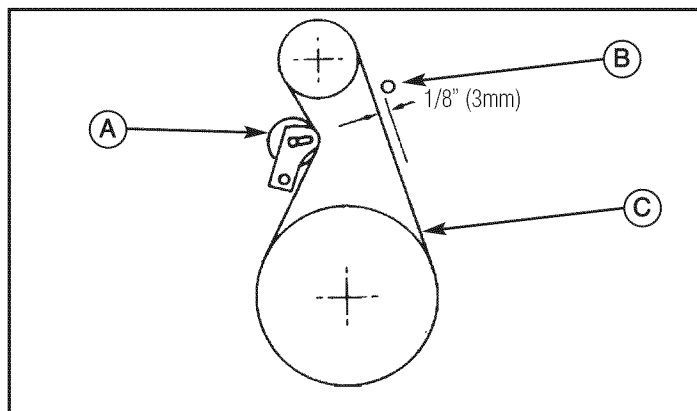

Adjusting Belt Drive

Figure 26

## MAINTENANCE

### SPEED CONTROL ROD ADJUSTMENT

If the speed control rod (A, Figure 27) requires adjustment, see an authorized dealer for assistance.

### CHECK AND ADJUST THE CABLES

The cables are adjusted at the factory and no adjustment should be necessary. If the cables have become stretched or are sagging adjustment will be necessary.

Whenever belts are adjusted or replaced, the cables will need to be adjusted.

### AUGER CONTROL CABLE ADJUSTMENT



**WARNING: Do not over-tighten, as this may lift the lever and cause the auger drive to be engaged without depressing the auger drive control.**

1. With the auger drive control lever released, the hook (A, Figure 28) should barely touch the lever (B) without raising it. There can be a maximum of 1/32" (0.8 mm) clearance.
2. To adjust, loosen the nut (C) by holding the adjusting flats (D) and turning the nut. Then, turn the adjusting flats and hold the adjustment screw (E). The adjustment screw is a phillips screw and the head can be held or turned by inserting a screwdriver through the spring (F).
3. Hold the adjusting flats and tighten the nut.
4. Start the engine and check the auger. The auger must not be engaged unless the auger drive control lever is depressed.
5. With the engine running, fully depress the auger drive control lever. The auger should engage and run normally.
6. Release the auger drive control lever. **The auger must stop within 5 seconds.**
7. If the auger does not operate properly, stop the engine and recheck the auger drive cable adjustment.
8. If the drive linkage is properly adjusted, the tension of the auger drive belt may require an adjustment (see "Belt Adjustment" section).

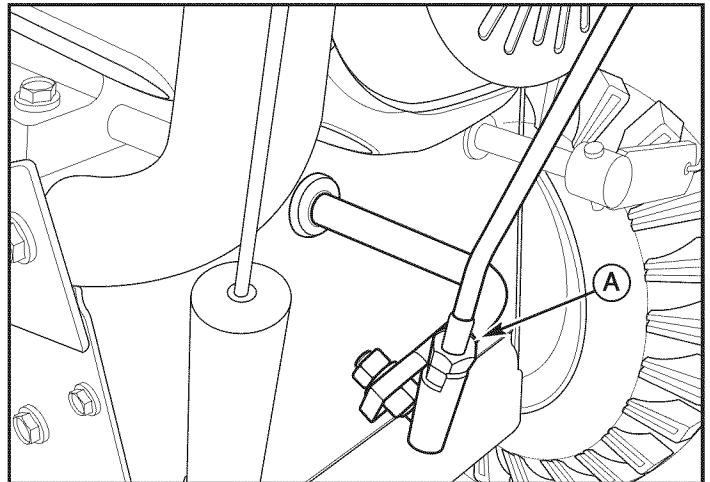

Adjusting Speed Control Rod

Figure 27

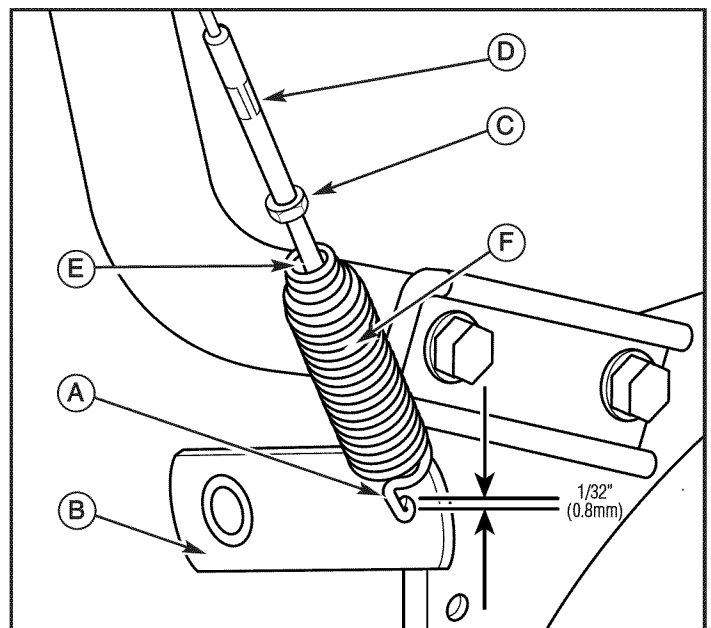

Adjusting Auger Control Cable

Figure 28



**TRACTION CONTROL CABLE ADJUSTMENT**

1. Remove the gas from the gas tank. Stand the snow thrower up on the front end of the auger housing.

**⚠ WARNING: Drain the gasoline outdoors, away from fire or flame.**

2. Loosen the bolts (A, Figure 29) on each side of the bottom panel (B).
3. Remove the bottom panel.
4. Slide the cable boot (A, Figure 30) off the cable adjustment bracket (B).
5. Push the bottom of the traction drive cable (C) through the cable adjustment bracket until the "Z" hook (D) can be removed.
6. Remove the "Z" hook from the cable adjustment bracket. Move the "Z" hook down to the next adjustment hole.
7. Pull the traction drive cable up through the cable adjustment bracket.
8. Put the cable boot over the cable adjustment bracket.
9. To check the adjustment, depress the drive lever and check the length of the drive spring (A, Figure 31). In correct adjustment, the length of the drive spring is a minimum 3 inches (76 mm) and a maximum 3-3/8 inches (85 mm).
10. Install the bottom panel (B, Figure 29).
11. Tighten the bolts (A) on each side of the bottom panel.

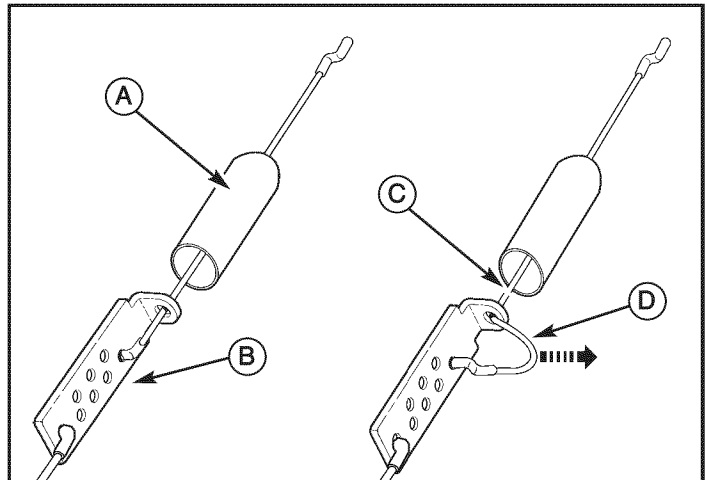

Traction Drive Cable

**Figure 30**

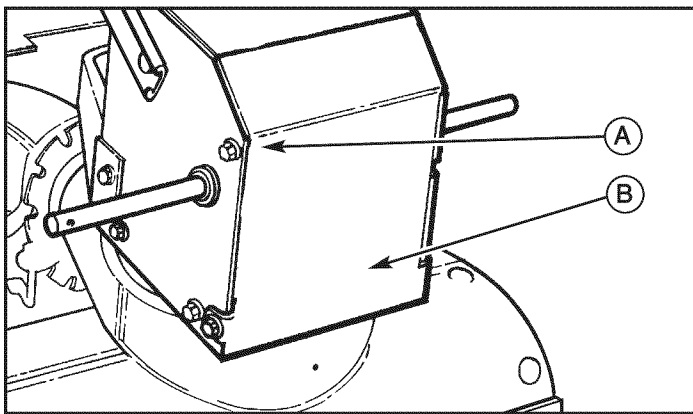

Adjusting Traction Drive Cable

**Figure 29**

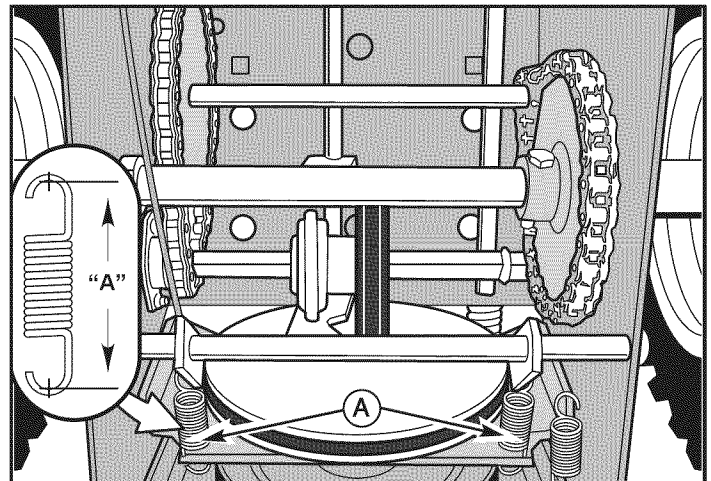

Checking Adjustment of Traction Drive Cable

**Figure 31**

## MAINTENANCE

### CHUTE ROTATION MOTOR ADJUSTMENT

If the electric chute rotator does not function properly, check the electrical connections and then perform the procedure below.

1. Remove the rotator motor cover.
2. Lubricate the chute ring gear.
3. Loosen the screws (A, Figure 32) securing the rotator motor and adjust so that the motor gear and chute ring gear mesh. Tighten the capscrews.
4. Reinstall the chute rotation cover.

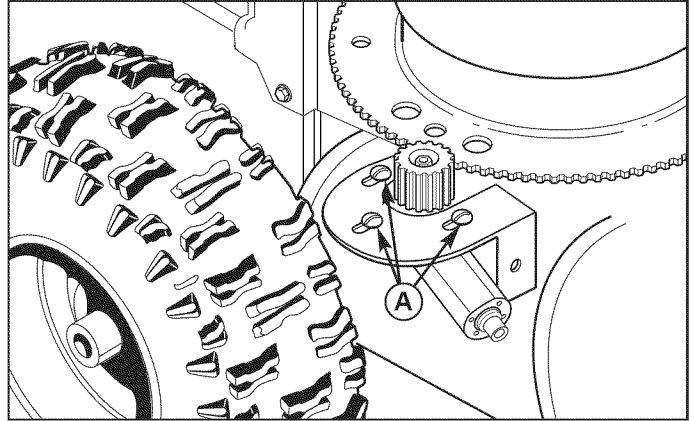

Adjusting Chute Rotation Motor

Figure 32

### AUGER SHEAR PIN REPLACEMENT

The augers are secured to the auger shaft with special shear pins that are designed to break if an object becomes lodged in the auger housing. Use of a harder grade shear pin will reduce the protection provided by the shear pin.

**WARNING: Do not go near the discharge chute or auger when the engine is running. Do not run the engine if any cover or guard is removed.**

Under most circumstances, if the auger strikes an object which could cause damage to the unit, the shear pin will break. This protects the gear box and other parts from damage.

The shear pins (A and B, Figure 33) are located on the auger shaft. Replace a broken shear pin as follows.

1. Tap out the broken shear pin with a pin punch.
2. Install a new shear pin and cotter pin. Bend the ends of the cotter pin down.

**IMPORTANT: Do not replace shear pins with anything other than the correct grade replacement shear pin. Use of bolts, screws, or harder grade shear pins can result in equipment damage.**

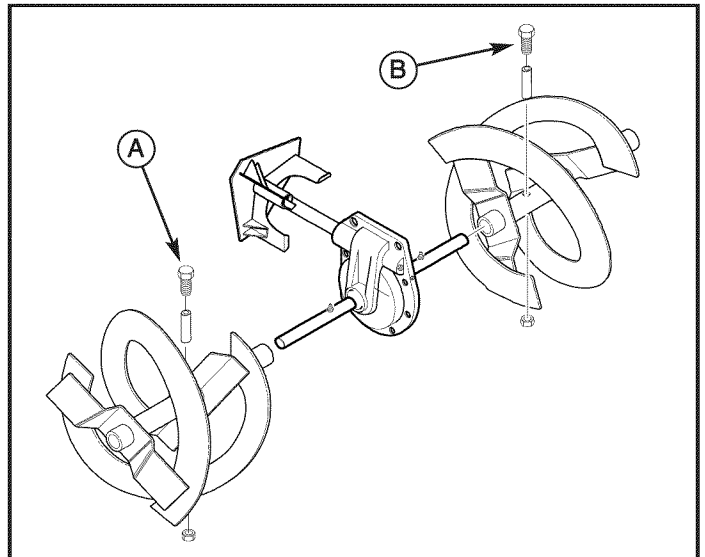

Replacing Broken Shear Pin

Figure 33

**CHECK THE TIRES**

Check tires for damage. Check the air pressure in the tires with an accurate gauge (see Figure 34).

**CAUTION: Avoid Injury! Explosive separation of tire and rim parts is possible when they are serviced incorrectly.**

- Do not attempt to mount a tire without the proper equipment and experience to perform the job.
- Do not inflate the tires above the recommended pressure.
- Do not weld or heat a wheel and tire assembly. Heat can cause an increase in air pressure resulting in an explosion. Welding can structurally weaken or deform the wheel.
- Do not stand in front or over the tire assembly when inflating. Use appropriate tool that allows you to stand to one side.

**NOTICE: Check side of tire for maximum tire pressure. DO NOT exceed maximum.**

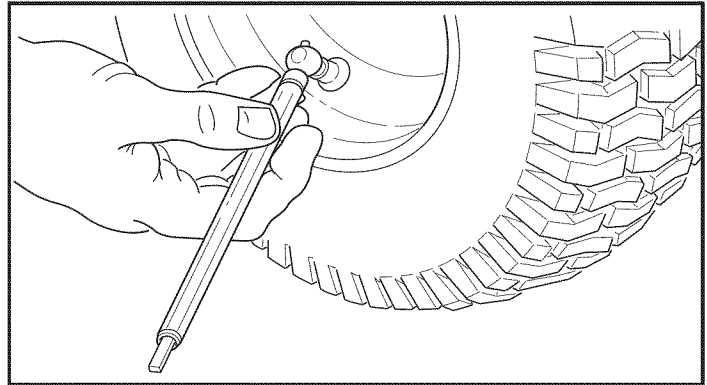

Checking Tire Air Pressure

**Figure 34**

# STORAGE

## OFF SEASON STORAGE

**WARNING:** Never store the engine, with fuel in the tank, indoors or in a poor ventilated enclosure where fuel fumes could reach an open flame, spark or pilot light as on a furnace, water heater, clothes dryer, etc.

Handle gasoline carefully. It is highly flammable and careless use could result in serious fire damage to your person and/or property.

Drain fuel into approved containers outdoors, away from open flame.

If the snow thrower will be stored for thirty (30) days or more at the end of the snow season, the following steps are recommended to prepare your snow thrower for storage.

**NOTE:** Gasoline must be removed or treated to prevent gum deposits from forming in the tank, filter, hose, and carburetor during storage.

1. Remove gasoline, by running engine until tank is empty and engine stops. If you do not want to remove the gasoline, add fuel stabilizer to any gasoline left in the tank to minimize gum deposits and acids. If the tank is almost empty, mix stabilizer with fresh gasoline in a separate container and add some of the mixture to the tank. ALWAYS FOLLOW INSTRUCTIONS ON STABILIZER CONTAINER. THEN RUN ENGINE AT LEAST 10 MINUTES AFTER STABILIZER IS ADDED TO ALLOW MIXTURE TO REACH CARBURETOR. STORE SNOW THROWER IN SAFE PLACE.
2. You can help keep your engine (4-cycles only) in good operating condition by changing oil before storage.
3. Lubricate the piston/cylinder area. This can be done by first removing the spark plug and squirting clean engine oil into the spark plug hole. Then cover the spark plug hole with a rag to absorb oil spray. Next, rotate the engine by pulling the starter two or three times. Finally, reinstall spark plug and attach spark plug wire.
4. Thoroughly clean the snow thrower.
5. Lubricate all lubrication points (see "Lubrication" topics in the MAINTENANCE section).
6. Make sure all nuts, bolts, and screws are securely fastened. Inspect all visible moving parts for damage, breakage, and wear. Replace if necessary.
7. Touch up all rusted or chipped paint surfaces; sand lightly before painting.
8. Cover the bare metal parts of the snow thrower housing auger, and the impeller with rust preventative.
9. If possible, store your snow thrower indoors and cover it to give protection from dust and dirt.
10. On models with folding handles, loosen the knobs that secure the upper handle. Rotate the upper handle back.
11. If the machine must be stored outdoors, block up the snow thrower and ensure the entire machine is off the ground. Cover the snow thrower with a heavy tarpaulin.

## LUBRICATE HEX SHAFT AND CHAINS

**CAUTION:** Do not allow grease or oil to contact the rubber friction wheel or the disc drive plate. If the disc drive plate or friction wheel come in contact with grease or oil damage to rubber friction wheel will result.

**NOTICE:** If grease or oil comes into contact with the disc drive plate or friction wheel, make sure to clean plate and wheel thoroughly with an alcohol base solvent.

1. Position speed select lever (E, Figure 4) in first forward gear.
2. Drain fuel to an approved container.
3. Stand the snow thrower up on the auger housing end.

**NOTE:** When the crankcase is filled with oil, do not leave the snow thrower standing up on the auger housing for an extended period of time.

4. Remove the bottom panel.
5. Lubricate the chains (A, Figure 35) with a chain type lubricant.
6. Wipe the hex shaft (B) and sprockets (C) with 5W30 motor oil, before storage and at the beginning of each season.
7. Install the bottom panel.

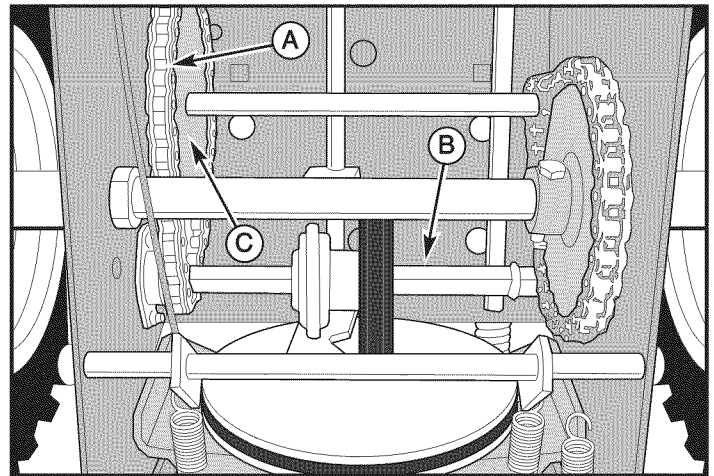

Lubricating Hex Shaft and Chains

Figure 35

## REMOVE FROM STORAGE

1. Put the upper handle in the operating position, tighten the knobs that secure the upper handle.
2. Fill the fuel tank with a fresh fuel.
3. Check the spark plug. Make sure the gap is correct. If the spark plug is worn or damaged, replace before using.
4. Make sure all fasteners are tight.
5. Make sure all guards, shields, and covers are in place.
6. Make sure all adjustments are correct.

PROBLEM	LOOK FOR	REMEDY
<b>Auger does not stop within 5 seconds after right control lever is released.</b>	Free-Hand™ control is ACTIVE.	Release both auger control and Free-Hand™ control to stop auger.
	Auger drive belt out of adjustment.	Adjust auger belt.
	Auger belt guide out of adjustment.	Adjust auger belt guide.
<b>Discharge chute or deflector does not work (electric).</b>	Electrical failure.	See authorized dealer.
<b>Discharge chute or deflector does not work (remote-manual).</b>	Discharge chute or deflector out of adjustment or needs lubrication.	Adjust and/or lubricate control linkage.
<b>Drive fails to move snow thrower at slow speeds.</b>	Traction control out of adjustment.	Readjust drive, or select speed lever setting one speed faster.
<b>Engine fails to start.</b>	Key is off.	Push key in to the ON position.
	Failure to prime a cold engine.	Press primer button twice and restart.
	Fuel shut-off valve is in CLOSED position.	Turn valve to OPEN position.
	Out of fuel.	Fill fuel tank.
	Choke OFF - cold engine.	Turn choke ON, set throttle to FAST.
	Engine flooded.	Turn choke to OFF; try starting.
	No spark.	Check gap. Gap spark plug, clean electrode, or replace plug as necessary.
	Water in fuel, or old fuel.	Drain tank. (Dispose of fuel at an authorized hazardous waste facility.) Fill with fresh fuel.
<b>Engine starts hard or runs poorly.</b>	Fuel mixture too rich.	Move choke to OFF position.
	Spark plug faulty, fouled, or gapped improperly.	Clean and gap spark plug, or replace.
	Fuel cap vent is blocked.	Clear vent.
<b>Excessive vibration.</b>	Loose parts or damaged impeller.	Stop engine immediately. Tighten all hardware. If vibration continues, have the unit serviced by an authorized dealer.
<b>Snow thrower does not stop when traction control lever is released.</b>	Traction control out of adjustment.	Adjust traction control linkage.
<b>Snow thrower veers to one side.</b>	Tire pressure not equal.	Check tire pressure.
	One wheel is set in free-wheeling mode. (Traction lock pin is in the OUTER hole.)	Make sure the left traction lock pin is in the INNER holes (to engage the traction drive).

## TROUBLESHOOTING

PROBLEM	LOOK FOR	REMEDY
<b>Scraper bar does not clean hard surface.</b>	Skid shoes improperly adjusted.	Raise or lower skid shoes.
<b>Unit fails to propel itself.</b>	Drive belt loose or damaged.	Replace drive belt. See authorized dealer.
	Incorrect adjustment of traction drive cable.	Adjust traction drive cable. Refer to "Cable Adjustment" in the MAINTENANCE section of this manual.
	Worn or damaged friction disc.	Replace friction disc. See authorized dealer.
<b>Unit fails to discharge snow.</b>	Auger drive belt loose or damaged.	Replace or adjust auger drive belt. Refer to "Drive Belt Adjustment" in the MAINTENANCE section of this manual, or see authorized dealer.
	Auger control cable not adjusted correctly.	Adjust auger control cable. Refer to "Cable Adjustment" in the MAINTENANCE section of this manual.
	Broken shear pin.	Replace shear pin. Refer to "Auger Shear Pin Replacement" in the MAINTENANCE section of this manual.
	Discharge chute clogged.	Stop engine immediately. Always use the clean-out tool to clear a clogged discharge chute, not your hands. Clean discharge chute and inside of auger housing. Refer to WARNINGS in OPERATOR SAFETY section.
	Foreign object lodged in auger.	Stop engine immediately. Always use the clean-out tool to clear a clogged chute, not your hands. Remove object from auger. Refer to WARNINGS in OPERATOR SAFETY section.

**LIMITED WARRANTY**

Briggs & Stratton Power Products Group, LLC will repair and/or replace, free of charge, any part(s) of the equipment that is defective in material or workmanship or both. Briggs & Stratton Corporation will repair and/or replace, free of charge, any part(s) of the Briggs and Stratton engine\* (if equipped) that is defective in material or workmanship or both. Transportation charges on product submitted for repair or replacement under this warranty must be borne by purchaser. This warranty is effective for the time periods and subject to the conditions stated below. For warranty service, find the nearest Authorized Service Dealer using our dealer locator at [www.BriggsandStratton.com](http://www.BriggsandStratton.com).

There is no other express warranty. Implied warranties, including those of merchantability and fitness for a particular purpose, are limited to one year from purchase or to the extent permitted by law. Liability for incidental or consequential damages are excluded to the extent exclusion is permitted by law.

Some states or countries do not allow limitations on how long an implied warranty lasts, and some states or countries do not allow the exclusion or limitation of incidental or consequential damages, so the above limitation and exclusion may not apply to you. This warranty gives you specific legal rights and you may also have other rights which vary from state to state or country to country.

**WARRANTY PERIOD**

<u>Item</u>	<u>Consumer Use</u>	<u>Commercial Use:</u>
Equipment	2 Years	90 Days
Engine*	2 Years	90 Days
Battery	1 Year	1 Year

The warranty period begins on the date of purchase by the first retail consumer or commercial end user, and continues for the period of time stated above. "Consumer use" means personal residential household use by a retail consumer. "Commercial use" means all other uses, including use for commercial, income producing or rental purposes. Once product has experienced commercial use, it shall thereafter be considered as commercial use for purposes of this warranty.

No warranty registration is necessary to obtain warranty on Briggs & Stratton products. Save your proof of purchase receipt. If you do not provide proof of the initial purchase date at the time warranty service is requested, the manufacturing date of the product will be used to determine warranty eligibility.

**ABOUT YOUR WARRANTY**

We welcome warranty repair and apologize to you for being inconvenienced. Warranty service is available only through servicing dealers authorized by Briggs & Stratton or BSPPG, LLC.

Most warranty repairs are handled routinely, but sometimes requests for warranty service may not be appropriate. This warranty only covers defects in materials or workmanship. It does not cover damage caused by improper use or abuse, improper maintenance or repair, normal wear and tear, or stale or unapproved fuel.

**Improper Use and Abuse** - The proper, intended use of this product is described in the Operator's Manual. Using the product in a way not described in the Operator's Manual or using the product after it has been damaged will void your warranty. Warranty is not allowed if the serial number on the product has been removed or the product has been altered or modified in any way, or if the product has evidence of abuse such as impact damage, or water/chemical corrosion damage.

**Improper Maintenance or Repair** - This product must be maintained according to the procedures and schedules provided in the Operator's Manual, and serviced or repaired using genuine Briggs & Stratton parts. Damage caused by lack of maintenance or use of non-original parts is not covered by warranty.

**Normal Wear** - Like all mechanical devices, your unit is subject to wear even when properly maintained. This warranty does not cover repairs when normal use has exhausted the life of a part or the equipment. Maintenance and wear items such as filters, belts, cutting blades, and brake pads (engine brake pads are covered) are not covered by warranty due to wear characteristics alone, unless the cause is due to defects in material or workmanship.

**Stale Fuel** - In order to function correctly, this product requires fresh fuel that conforms to the criteria specified in the Operator's Manual. Damage caused by stale fuel (carburetor leaks, clogged fuel tubes, sticking valves, etc) is not covered by warranty.

\* Applies to Briggs and Stratton engines only. Warranty coverage of non-Briggs and Stratton engines is provided by the engine manufacturer.

# CALIFORNIA, U.S. EPA, AND BRIGGS & STRATTON CORPORATION EMISSIONS CONTROL WARRANTY STATEMENT YOUR WARRANTY RIGHTS AND OBLIGATIONS

Effective November 2008

The California Air Resources Board, U.S. EPA, and Briggs & Stratton (B&S) are pleased to explain the emissions control system warranty on your Model Year 2008 and later engine/equipment. In California, new small off-road engines must be designed, built, and equipped to meet the State's stringent anti-smog standards. B&S must warrant the emissions control system on your engine/equipment for the periods of time listed below provided there has been no abuse, neglect, or improper maintenance of your small off-road engine.

Your emissions control system may include parts such as the carburetor or fuel injection system, fuel tank, ignition system, and catalytic converter. Also included may be hoses, belts, connectors, sensors, and other emissions-related assemblies. Where a warrantable condition exists, B&S will repair your engine/equipment at no cost to you including diagnosis, parts, and labor.

## Manufacturer's Warranty Coverage:

Small off-road engines are warranted for two years. If any emissions-related part on your engine/equipment is defective, the part will be repaired or replaced by B&S.

## Owner's Warranty Responsibilities:

- As the small engine/equipment owner, you are responsible for the performance of the required maintenance listed in your owner's manual. B&S recommends that you retain all receipts covering maintenance on your engine/equipment, but B&S cannot deny warranty solely for the lack of receipts or your failure to ensure the performance of all scheduled maintenance.
- As the engine/equipment owner, you should however be aware that B&S may deny you warranty coverage if your engine/equipment or a part has failed due to abuse, neglect, improper maintenance, or unapproved modifications.
- You are responsible for presenting your engine/equipment to a B&S distribution center, servicing dealer, or other equivalent entity, as applicable, as soon as a problem exists. The warranty repairs should be completed in a reasonable amount of time, not to exceed 30 days. If you have any questions regarding your warranty rights and responsibilities, you should contact B&S at (414) 259-5262.

## BRIGGS & STRATTON EMISSIONS CONTROL WARRANTY PROVISIONS

The following are specific provisions relative to your Emissions Control Warranty Coverage. It is in addition to the B&S engine warranty for non-regulated engines found in the Operator's Manual.

### 1. Warranted Emissions Parts

Coverage under this warranty extends only to the parts listed below (the emissions control systems parts) to the extent these parts were present on the engine purchased.

- a. Fuel Metering System
  - Cold start enrichment system (soft choke)
  - Carburetor and internal parts
  - Fuel pump
  - Fuel line, fuel line fittings, clamps
  - Fuel tank, cap and tether
  - Carbon canister
- b. Air Induction System
  - Air cleaner
  - Intake manifold
  - Purge and vent line
- c. Ignition System
  - Spark plug(s)
  - Magneto ignition system
- d. Catalyst System
  - Catalytic converter
  - Exhaust manifold
  - Air injection system or pulse valve
- e. Miscellaneous Items Used in Above Systems
  - Vacuum, temperature, position, time sensitive valves and switches
  - Connectors and assemblies

### 2. Length of Coverage

For a period of two years from date of original purchase, B&S warrants to the original purchaser and each subsequent purchaser that the engine is designed, built, and equipped so as to conform with all applicable regulations adopted by the Air Resources Board; that it is free from defects in material and workmanship that could cause the failure of a warranted part; and that it is identical in all material respects to the engine described in the manufacturer's application for certification. The warranty period begins on the date the engine is originally purchased.

The warranty on emissions-related parts is as follows:

- Any warranted part that is not scheduled for replacement as required maintenance in the owner's manual supplied, is warranted for the warranty period stated above. If any such part fails during the period of warranty coverage, the part will be repaired or replaced by B&S at no charge to the owner. Any such part repaired or replaced under the warranty will be warranted for the remaining warranty period.
- Any warranted part that is scheduled only for regular inspection in the owner's manual supplied, is warranted for the warranty period stated above. Any such part repaired or replaced under warranty will be warranted for the remaining warranty period.
- Any warranted part that is scheduled for replacement as required maintenance in the owner's manual supplied, is warranted for the period of time prior to the first scheduled replacement point for that part. If the part fails prior to the first scheduled replacement, the part will be repaired or replaced by B&S at no charge to the owner. Any such part repaired or replaced under warranty will be warranted for the remainder of the period prior to the first scheduled replacement point for the part.
- Add on or modified parts that are not exempted by the Air Resources Board may not be used. The use of any non exempted add on or modified parts by the owner will be grounds for disallowing a warranty claim. The manufacturer will not be liable to warrant failures of warranted parts caused by the use of a non exempted add on or modified part.

### 3. Consequential Coverage

Coverage shall extend to the failure of any engine components caused by the failure of any warranted emissions parts.

### 4. Claims and Coverage Exclusions

Warranty claims shall be filed according to the provisions of the B&S engine warranty policy. Warranty coverage does not apply to failures of emissions parts that are not original equipment B&S parts or to parts that fail due to abuse, neglect, or improper maintenance as set forth in the B&S engine warranty policy. B&S is not liable for warranty coverage of failures of emissions parts caused by the use of add-on or modified parts.

## LOOK FOR RELEVANT EMISSIONS DURABILITY PERIOD AND AIR INDEX INFORMATION ON YOUR ENGINE EMISSIONS LABEL

Engines that are certified to meet the California Air Resources Board (CARB) Emissions Standard must display information regarding the Emissions Durability Period and the Air Index. Briggs & Stratton makes this information available to the consumer on our emissions labels. The engine emissions label will indicate certification information.

The **Emissions Durability Period** describes the number of hours of actual running time for which the engine is certified to be emissions compliant, assuming proper maintenance in accordance with the Operating & Maintenance Instructions. The following categories are used:

### Moderate:

Engine is certified to be emissions compliant for 125 hours of actual engine running time.

### Intermediate:

Engine is certified to be emissions compliant for 250 hours of actual engine running time.

### Extended:

Engine is certified to be emissions compliant for 500 hours of actual engine running time.

For example, a typical walk-behind lawn mower is used 20 to 25 hours per year. Therefore, the **Emissions Durability Period** of an engine with an **intermediate** rating would equate to 10 to 12 years.

Briggs & Stratton engines are certified to meet the United States Environmental Protection Agency (USEPA) Phase 2 emissions standards. For Phase 2 certified engines, the Emissions Compliance Period referred to on the Emissions Compliance label indicates the number of operating hours for which the engine has been shown to meet Federal emissions requirements.

For engines less than 225 cc displacement:

- Category C = 125 hours
- Category B = 250 hours
- Category A = 500 hours

For engines of 225 cc or more displacement:

- Category C = 250 hours
- Category B = 500 hours
- Category A = 1000 hours











The logo features the word "SNAPPER" in a bold, italicized, sans-serif font. The text is white and is set against a black, horizontally-oriented oval background. The oval has a white outline and a slight shadow effect, giving it a three-dimensional appearance. The entire logo is positioned in the upper right corner of a white rectangular frame.

**SNAPPER**

Briggs & Stratton Power Products Group, L.L.C.  
Copyright © 2009 Briggs & Stratton Corporation  
Milwaukee, WI USA. All Rights Reserved  
[www.BRIGGSandSTRATTON.com](http://www.BRIGGSandSTRATTON.com)  
[www.snapper.com](http://www.snapper.com)