

**SEARS  
OWNERS  
MANUAL**

**MODEL NO.  
917.249393**

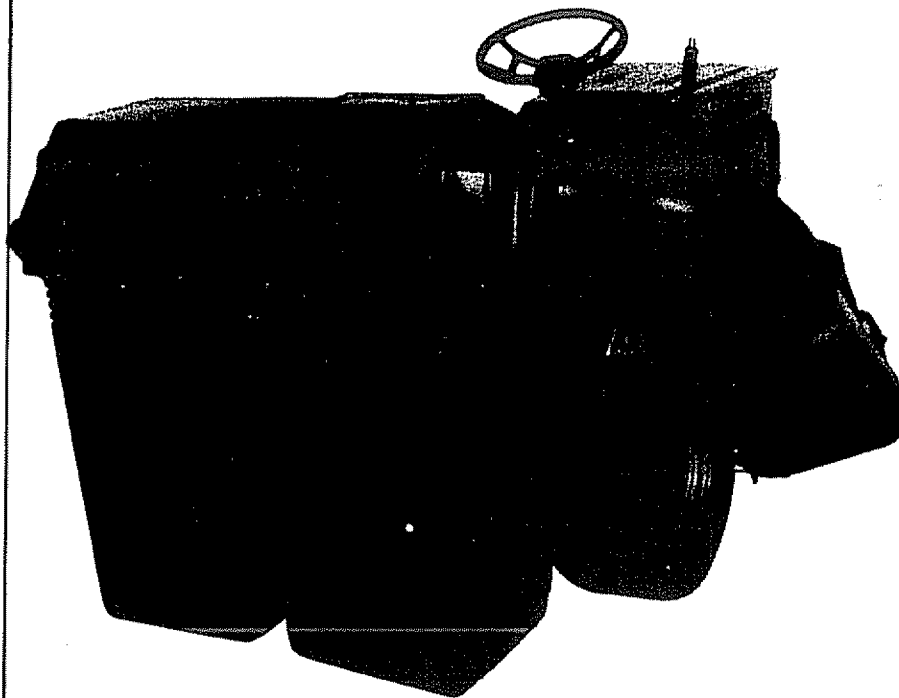

**Caution:  
Read and Follow  
All Safety Rules  
And Instructions  
Before Operating  
This Equipment.**

**CRAFTSMAN®  
GRASS CATCHER**

*Assembly  
Installation  
Operation  
Repair Parts*

## SAFETY RULES

1. Know the controls and how to stop quickly. **READ THIS OPERATOR'S MANUAL** and instructions furnished with your tractor.
2. Do not allow children to operate the machine. Do not allow adults to operate it without proper instruction.
3. Do not carry passengers. Do not mow when children and others are around.
4. Always wear substantial footwear. Do not wear loose fitting clothing that could get caught in moving parts.
5. Keep your eyes and mind on your tractor, mower and the area being cut. Do not let other interests distract you.
6. Do not attempt to operate your tractor or mower when not in the drivers seat.
7. Always get on or off your tractor from the operator's left hand side.
8. Clear the work area of objects (wire, rocks, etc.) which might be picked up and thrown.
9. Disengage all attachment clutches and return gear shift control to neutral before attempting to start the engine.
10. Disengage power to attachments and stop the engine before leaving the operator's position.
11. Disengage power to mower, stop the engine and disconnect spark plug wire(s) from spark plug(s) before cleaning, making an adjustment or repair. Be careful to avoid touching hot muffler or engine components.
12. Disengage power to attachments when transporting or not in use.
13. Take all possible precautions when leaving the vehicle unattended. Disengage the power-take-off, lower the attachments, return gear shift control lever to neutral, set the parking brake, stop the engine and remove the key.
14. Do not stop or start suddenly when going uphill or downhill. Mow up and down the face of slopes (not greater than 15°); never across the face. Refer to sight guide in tractor manual.
15. Reduce speed on slopes and make turns gradually to prevent tipping or loss of control. Exercise extreme caution when changing direction on slopes.
16. While going up or down slopes choose a speed low enough to negotiate the slope without stopping. To reduce speed, move gear shift control lever to neutral position.
17. Never mow in wet or slippery grass, when traction is unsure or at a speed which could cause a skid.
18. Stay alert for holes in the terrain and other hidden hazards. Keep away from drop-offs.
19. Do not drive too close to creeks, ditches and public highways.
20. Exercise special care when mowing around fixed objects in order to prevent the blades from striking them. Never deliberately run tractor or mower into or over any foreign objects.
21. Never shift gears until tractor comes to a stop.
22. Never place hands or feet under the mower, in discharge chute or near any moving parts while tractor or mower are running. Always keep clear of discharge chute.
23. Use care when pulling loads or using heavy equipment.
  - a. Use only approved drawbar hitch points.
  - b. Limit loads to those you can safely control.
  - c. Do not turn sharply. Use care when backing.
  - d. Use counterweight or wheel weights when suggested in the owner's manual.
24. Watch out for traffic when crossing or near roadways.
25. When using any attachments, never direct discharge of material toward bystanders nor allow anyone near the vehicle while in operation.
26. Handle gasoline with care - it is highly flammable.
  - a. Use approved gasoline containers.
  - b. Never remove the fuel cap of the fuel tank or add gasoline to a running or hot engine or an engine that has not been allowed to cool for several minutes after running. Never fill tank indoors, always clean up spilled gasoline.
  - c. Open doors if the engine is run in the garage - exhaust fumes are dangerous. Do not run the engine indoors.
27. Keep the vehicle and attachments in good operating condition, and keep safety devices in place and working.
28. Keep all nuts, bolts and screws tight to be sure the equipment is in safe working condition.
29. Never store the equipment with gasoline in the tank inside a building where fumes may reach an open flame or spark. Allow the engine to cool before storing in any enclosure.
30. To reduce fire hazard, keep the engine free of grass, leaves or excessive grease. Never attempt to clean product while engine is running.
31. Except for adjustments; **DO NOT** operate Engine if air cleaner or cover directly over carburetor air intake is removed. Removal of such part could create a fire hazard.
32. Do not operate without a muffler or tamper with exhaust system. Damaged mufflers or spark arresters could create a fire hazard. Inspect periodically and replace if necessary.
33. The vehicle and attachments should be stopped and inspected for damage after striking a foreign object and the damage should be repaired before restarting and operating the equipment.
34. Do not change the engine governor settings or overspeed the engine; severe damage or injury may result.
35. When using the vehicle with mower, proceed as follows:
  - a. Mow only in daylight or in good artificial light.
  - b. Shut the engine off when unclogging chute.
  - c. Check the blade mounting bolts for proper tightness at frequent intervals.
36. Do not operate the mower without entire grass catcher, on mowers so equipped or the deflector shield in place.
37. Disengage power to mower before backing up. Do not mow in reverse unless absolutely necessary and then only after careful observation of the entire area behind the mower.
38. Under normal usage the grass catcher bag material is subject to deterioration and wear. It should be checked frequently for bag replacement. Replacement bags should be checked to ensure compliance with the original manufacturer's recommendations or specifications.



**LOOK FOR THIS SYMBOL TO POINT OUT IMPORTANT SAFETY PRECAUTIONS. IT MEANS -- ATTENTION! BECOME ALERT! YOUR SAFETY IS INVOLVED.**

**CONGRATULATIONS** on your purchase of a Sears Craftsman Grass Catcher Attachment. It has been designed, engineered and manufactured to give you the best possible dependability and performance. Should you experience any problem you cannot easily remedy, please contact your nearest Sears Service Department. They have competent, well-trained technicians and the proper tools to repair this unit.

Please read and retain this manual. The instructions will enable you to assemble, operate, and maintain your Craftsman Grass Catcher properly. Always observe the "SAFETY RULES".

### **LIMITED ONE YEAR WARRANTY**

For one year from the date of purchase, when this grass catcher attachment is maintained according to the operating and maintenance instructions in the owner's manual, Sears will repair free of charge any defect in material or workmanship.

This warranty excludes blade(s) and blade adapter(s), which are expendable and become worn during normal use.

This warranty does not cover:

- repairs necessary because of operator abuse or negligence, including the failure to maintain the equipment according to instructions contained in the owner's manual; and
- grass catcher attachments used for commercial or rental purposes.

WARRANTY SERVICE IS AVAILABLE BY CONTACTING THE NEAREST SEARS SERVICE CENTER/DEPARTMENT IN THE UNITED STATES. This warranty applies only while this product is in use in the United States.

This warranty gives you specific legal rights, and you may also have other rights which vary from state to state.

SEARS, ROEBUCK AND CO., Dept. 698/731A Sears Tower, Chicago, IL 60684

# INDEX

## **A**

### **Assembly:**

|                            |    |
|----------------------------|----|
| <i>Grass Catcher</i> ..... | 11 |
| <i>Mower</i> .....         | 8  |

## **B**

|                           |    |
|---------------------------|----|
| <i>Bagging Tips</i> ..... | 15 |
| <i>Blade Care</i> .....   | 16 |

## **G**

|                                    |    |
|------------------------------------|----|
| <i>Grass Catcher Removal</i> ..... | 16 |
|------------------------------------|----|

## **M**

|                          |    |
|--------------------------|----|
| <i>Maintenance</i> ..... | 16 |
|--------------------------|----|

## **O**

|                        |    |
|------------------------|----|
| <i>Operation</i> ..... | 15 |
|------------------------|----|

## **P**

|                        |       |
|------------------------|-------|
| <i>Parts Bag</i> ..... | 5 - 7 |
|------------------------|-------|

## **R**

|                           |    |
|---------------------------|----|
| <i>Repair Parts</i> ..... | 18 |
|---------------------------|----|

## **S**

|                           |    |
|---------------------------|----|
| <i>Safety Rules</i> ..... | 2  |
| <i>Storage</i> .....      | 16 |

## **W**

|                       |   |
|-----------------------|---|
| <i>Warranty</i> ..... | 3 |
|-----------------------|---|

# ASSEMBLY

## Know Your Grass Catcher

READ THIS OWNER'S MANUAL BEFORE OPERATING YOUR GRASS CATCHER. If you understand the machine and its operation, you will achieve efficient and peak performance. While reading the manual, compare the illustrations with your Grass Catcher to familiarize yourself with the location of various controls and adjustments. Study the operating instructions and safety precautions thoroughly to insure proper functioning of your Grass Catcher and to prevent injury to yourself and others. Be sure to pay strict attention to all notes and cautions; they are included for your safety. Save this manual for future reference.

## Unpacking Instructions

1. Open Carton.
2. Remove Plastic Containers.
3. Remove Corrugated Fillers.
4. Remove Blades, Support Post and Grass Catcher Cover.



The operation of any tractor can result in foreign objects thrown into the eyes, which can result in severe eye damage. Always wear safety glasses or eye shields before starting your tractor and while mowing. We recommend Wide Vision Safety Mask for over the spectacles or standard safety glasses, available at Sears Retail or Catalog Stores.

**Mower Deck Hardware Parts Bags**  
Contents Not Shown Full Size



(2) Lower Blade Saddle

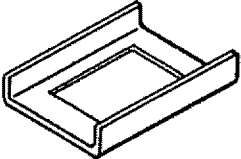

(2) Saddle



(1) Latch Pin



(1) Clamp

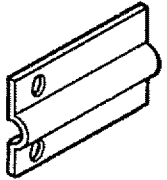

(1) Front Latch Bracket

**Mounting Bracket Hardware Parts Bag**  
Contents Not Shown Full Size

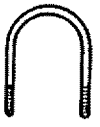

(1) U-Bolt, 1/4-20



(1) Latch Pin



(1) Hinge Bracket











(1) Elbow Clamp

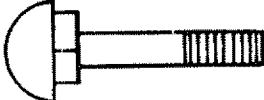

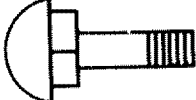

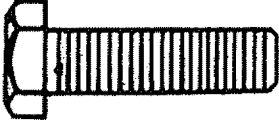



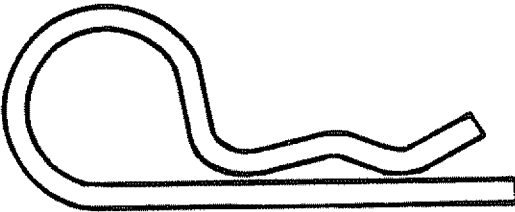

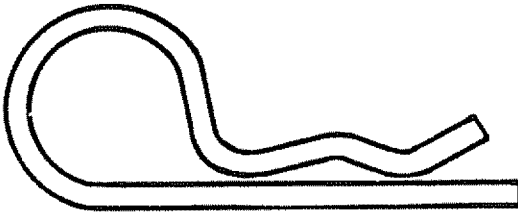

(1) End Plug

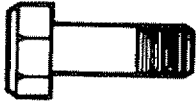

(1) Bracket Support Pin

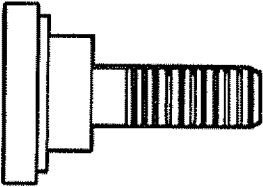
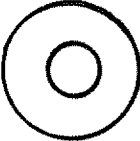
| ASSEMBLY LOCATION                  | MOWER DECK PARTS BAG SHOWN FULL SIZE   |
|------------------------------------|--|
| FRONT LATCH BRACKET AND RUNNER     |   <p>(3) Carriage Bolt, 5/16-18 x 1</p> <p>(3) Locknut, 5/16-18</p>  |
| LATCH ASSEMBLY AND DISCHARGE GUARD |   <p>(2) Carriage Bolt, 5/16-18 x .62</p> <p>(2) Locknut, 5/16-18</p>  |
| BLADES                             |    <p>(2) Hex Bolt, 3/8 - 24 x 1 - 3/4, Gr. 5</p> <p>(2) Lockwasher, 3/8</p> <p>(2) Washer .406 x 1 x .127/.112</p> |
| BAFFLE                             |   <p>(1) Hex Bolt, 1/4-20 x 1-1/4</p> <p>(1) Locknut, 1/4-20</p>   |
| CHUTE EXTENSION                    |  <p>(2) Retainer Spring</p>  |

| ASSEMBLY LOCATION           | MOUNTING BRACKET PARTS BAG SHOWN FULL SIZE  |
|-----------------------------|---|
| SUPPORT POST AND HOOD HINGE |  <p>(2) Retainer Spring</p>   |
| ELBOW RETAINER              |   <p>(2) Formed Washer</p> <p>(2) Locknut 5/16-18</p> |

|   |   |  |
|---|---|--|
| <p><b>HOOD<br/>HINGE</b></p>                | <br><p>(2) Hex Bolt, 1/4-20 x 3/4, Gr. 5</p>       | <br><p>(2) Locknut, 1/4-20</p>  |
| <p><b>U-BOLT</b></p>                        | <br><p>(4) Washer .28 x .62 x .06</p>              | <br><p>(2) Hex Nuts, 1/4 - 20</p> <br><p>(2) Locknut, 1/4-20</p>       |
| <p><b>REAR<br/>MOUNTING<br/>BRACKET</b></p> | <br><p>(1) Shoulder Bolt</p>                       | <br><p>(1) Washer</p> <br><p>(1) Locknut, 3/8-16</p>                   |
| <p><b>ELBOW</b></p>                         | <br><p>(1) Truss Head Screws<br/>10 - 24 x 1/2</p> | <br><p>(2) Washer No. 10</p> <br><p>(1) Acorn Lock Nut<br/>10 - 24</p> |

**GRASS CATCHER CARTON CONTENTS:**

- (1) R.H. Container Assembly with Frame
- (1) L.H. Container Assembly with Frame
- (1) Plastic Elbow
- (1) Plastic Chute Extension
- (1) Latch Assembly
- (1) R.H. Baffle
- (1) U-Bolt
- (1) Elbow Shield Assembly
- (1) Mower Deck Bag of Hardware
- (1) Mounting Bracket Bag of Hardware
- (1) Post Assembly
- (1) Tube and Handle Assembly
- (1) Mounting Bracket
- (2) Blades
- (1) Hood
- (1) Owner's Manual

# ASSEMBLY

## PARTS IDENTIFICATION

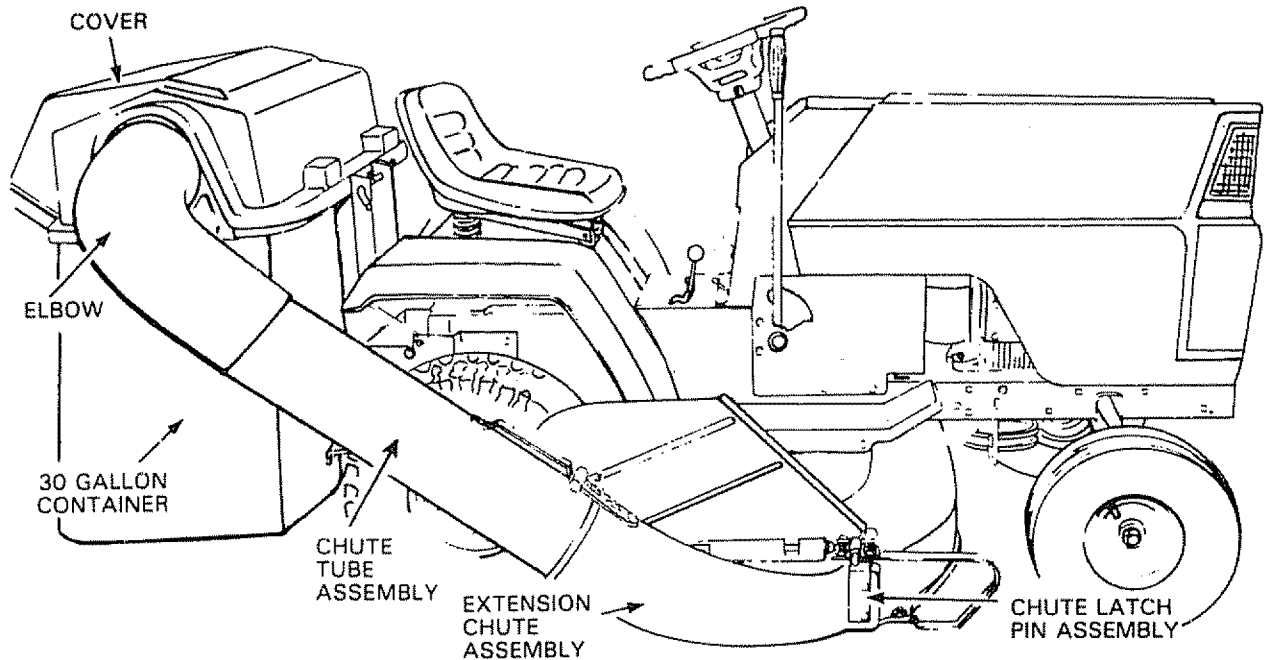

To assemble your grass catcher you will need:

- (1) 9/16" wrench
- (1) screwdriver, 6"
- (2) 1/2" wrenches
- (1) 3/8" wrench
- (2) 7/16" wrenches
- (1) 7/8" wrench

NOTE: RIGHT HAND (R.H.) AND LEFT HAND (L.H.) ARE DETERMINED FROM OPERATOR'S POSITION WHILE SEATED ON THE TRACTOR.

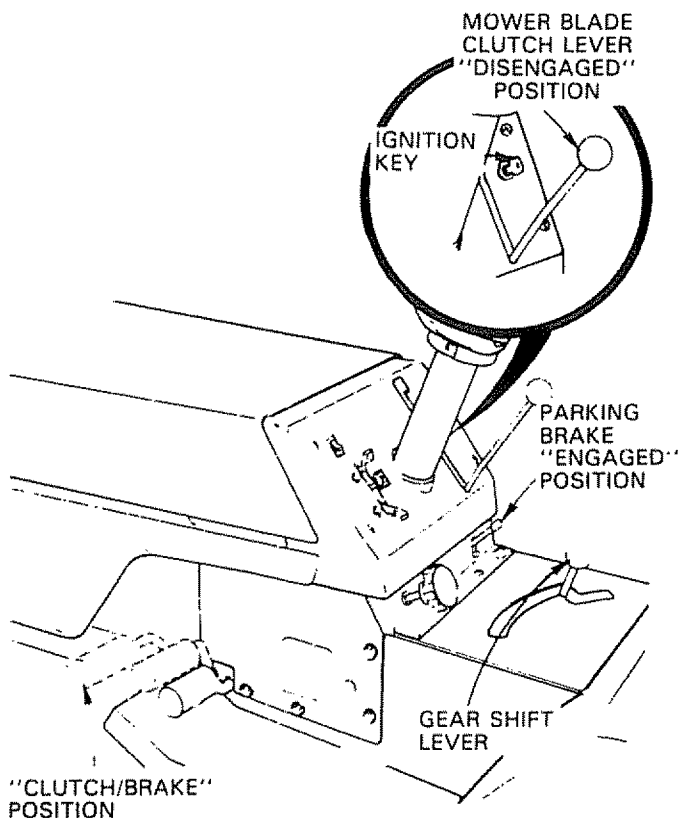

FIGURE 2

### ASSEMBLY-MOWER

**READ THE "SAFETY RULES" CAREFULLY BEFORE OPERATING YOUR GRASS CATCHER.**

**DO NOT OPERATE MOWER WITH GRASS CATCHER ASSEMBLY PARTIALLY INSTALLED.**

All hardware for mower assembly found in bag labeled "Mower Deck Hardware".

1. Turn ignition key (Fig. 2) to "OFF" position.

**REMOVE KEY TO PREVENT UNAUTHORIZED USE.**

**MAKE ABSOLUTELY SURE THE BLADES AND ALL MOVING PARTS HAVE COMPLETELY STOPPED.**

2. Push clutch-brake pedal completely into "BRAKE" position (Fig. 2).



3. Move gear shift lever (Fig. 2) to "Neutral" position.
4. Place parking brake (Fig. 2) in "ENGAGED" position. Raise parking brake lever and hold in "ENGAGED" position. Release clutch-brake pedal.
5. Disengage mower blade clutch lever (Fig. 2 - Inset).

**DISCONNECT THE SPARK PLUG WIRE(S) FROM THE SPARK PLUG(S) AND KEEP WIRE(S) AWAY FROM THE PLUG(S) TO PREVENT INJURY FROM ACCIDENTAL STARTING.**

6. Remove mower from tractor. Refer "To Remove Mower" in your tractor owners manual. For ease of assembly, turn the mower upside down.
7. Using a 9/16" wrench remove the bolts, lockwashers and washers securing the mower blades to the mandrel assemblies. Save hardware for later use when mower is used without grass catcher.
8. Mount grass catcher blades, lower blade saddles, upper blade saddles and mower blades to mandrel assemblies (Fig. 3) using: two 3/8 - 24 x 1 - 3/4 hex bolts gr.5, two lockwashers and two washers (shown full size below). Grass catcher blades, lower blade saddles, upper blade saddles and hardware furnished with grass catcher.

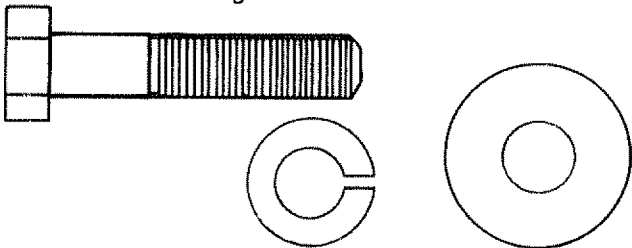

- a. Return mower blade (Fig. 3) to original position against mandrel assembly.
- b. Place upper blade saddle and lower blade saddle (Fig. 3) on mower blade. NOTE: Position flanges as shown in Fig. 3.
- c. Place grass catcher blade in lower blade saddle. NOTE: Be sure pointed edges of grass catcher blade are facing upward (Fig. 3).
- d. Secure grass catcher blade assembly to mandrel assembly using hex bolt, lockwasher and washer (Fig. 3). Tighten securely. NOTE: Lower blade saddle must be seated inside upper blade saddle (Fig. 3 - Inset). Repeat procedure for other blade.

**ALWAYS USE GRADE 5 HEAT TREATED BOLTS TO ATTACH BLADES. CHECK BOLTS IN BLADES OCCASIONALLY TO MAKE SURE BOLTS ARE TIGHT. TORQUE BOLTS 27 - 35 FT. LBS.**

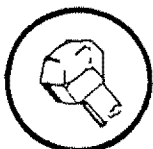

**A GRADE 5 HEAT TREATED BOLT CAN BE IDENTIFIED BY THREE LINES INDICATED ON THE BOLT HEAD AS SHOWN AT LEFT.**

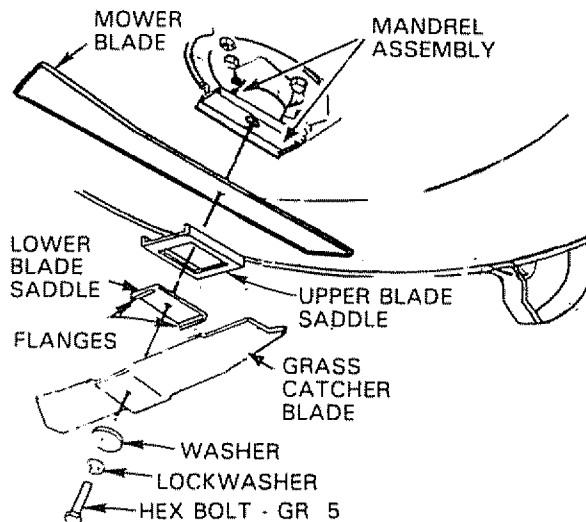

FIGURE 3 -

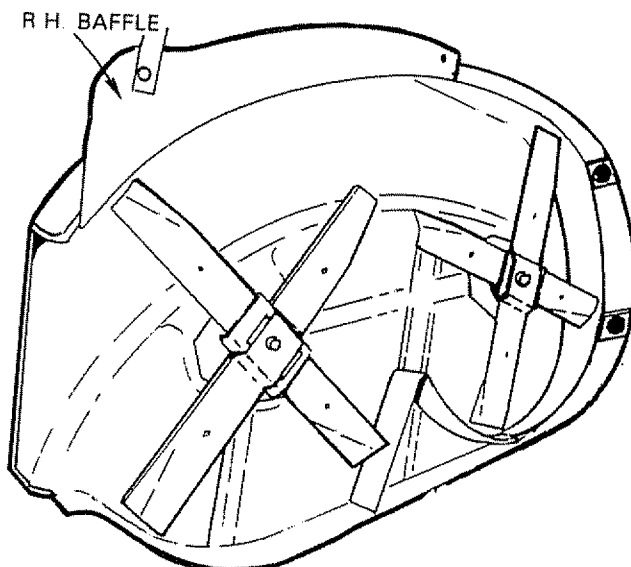
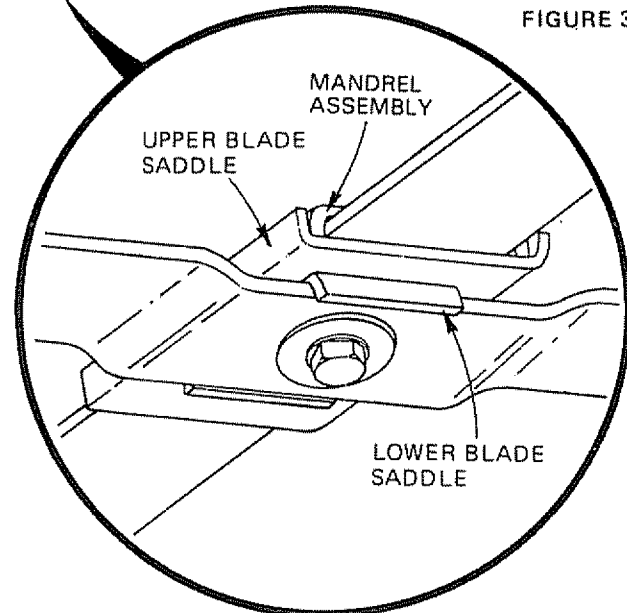

FIGURE 4

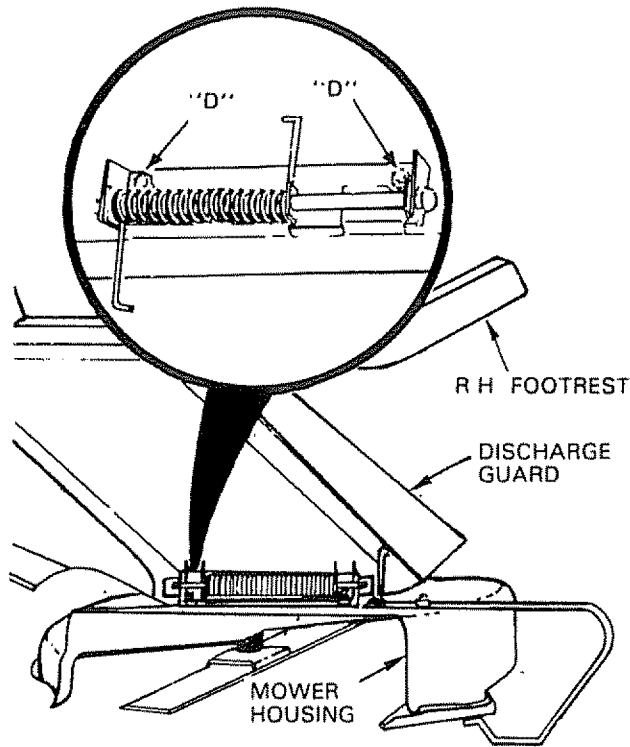

FIGURE 5

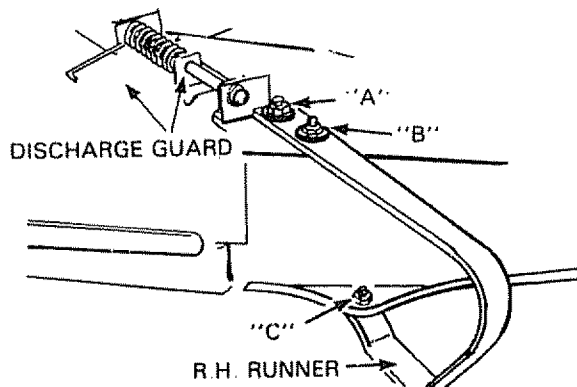

FIGURE 6

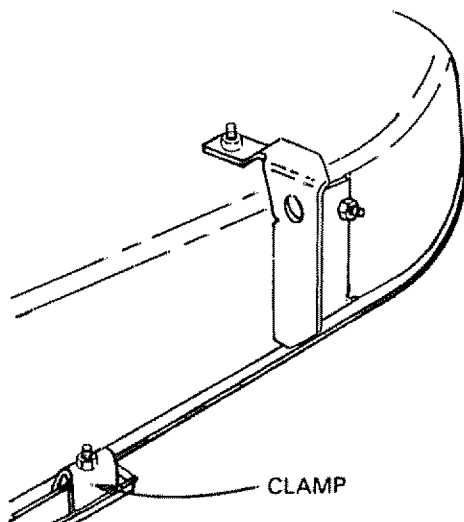

FIGURE 7

9. Using a 1/2" wrench remove hardware "D" (Fig. 5 - Inset) securing discharge guard to mower housing. Hardware may be discarded.
10. Using a 1/2" wrench remove hardware "A", "B" and "C" (Fig. 6) securing R.H. runner to mower housing. Hardware may be discarded.
11. Place R.H. baffle (Fig. 4) on lip of mower housing. Secure R.H. runner to R.H. baffle and mower housing using: one 5/16 carriage bolt and one 5/16 locknut (shown full size below). NOTE: Do not tighten. R.H. baffle and hardware furnished with grass catcher.



12. Secure R.H. baffle to mower housing using: one clamp, one 1/4 hex bolt and one 1/4 locknut (shown full size below). Clamp and hardware furnished with grass catcher.



- a. Place clamp (Fig. 7) over hole in R.H. baffle (Fig. 7). Bolt head to underside of mower housing. Tighten securely.

13. Assemble front latch bracket to top of R.H. runner (Fig. 8) using: two 5/16 carriage bolts and two 5/16 locknuts (shown full size below). Bolt heads to underside of mower housing. Tighten securely. Front latch bracket and hardware furnished with grass catcher. NOTE: Tighten hardware assembled in step 11.

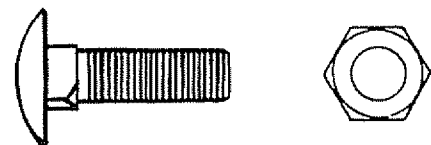

14. Attach discharge guard to latch assembly and mower housing (Fig. 8) using two 5/16 carriage bolts and two 5/16 locknuts (shown full size below). Bolt heads to underside of mower housing. Tighten securely. Hardware furnished with grass catcher.



15. Reattach mower to tractor. Refer to "Mower Installation" in your tractor owners manual.

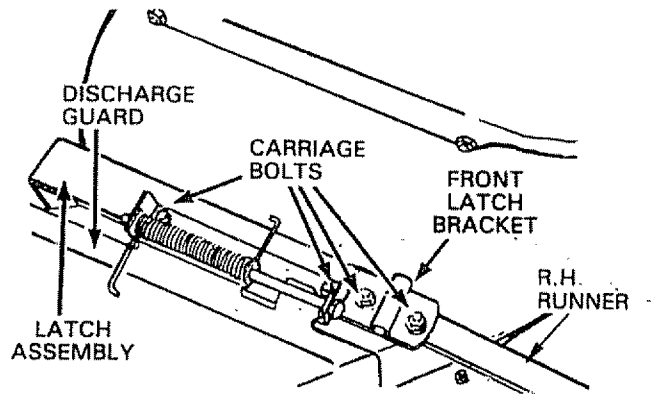
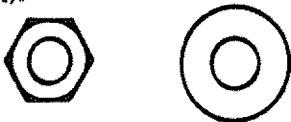

FIGURE 8

### ASSEMBLY-GRASS CATCHER

All hardware for grass catcher assembly is found in bag labeled "Mounting Bracket Hardware".

1. Locate u-bolt in parts bag. Place two 1/4 hex nuts and two washers (shown full size below) on u-bolt (Fig. 9 - inset).



NOTE: Run nuts on u-bolt as shown in illustration below. U-bolt and hardware furnished with grass catcher.

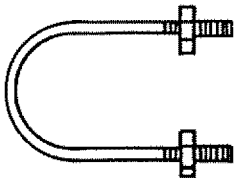

2. Insert u-bolt through slot in drawbar as shown in Fig. 9.

3. Place the rear mounting bracket (Fig. 9) on u-bolt and secure with two washers and two 1/4 locknuts (shown full size below). Tighten finger tight. Rear mounting bracket and hardware furnished with grass catcher.



4. Secure the rear mounting bracket to the drawbar (Fig. 9) using: one shoulder bolt, one washer and one 3/8 locknut (shown full size below). Tighten securely. NOTE: Tighten hardware assembled in step 3. Hardware furnished with grass catcher.

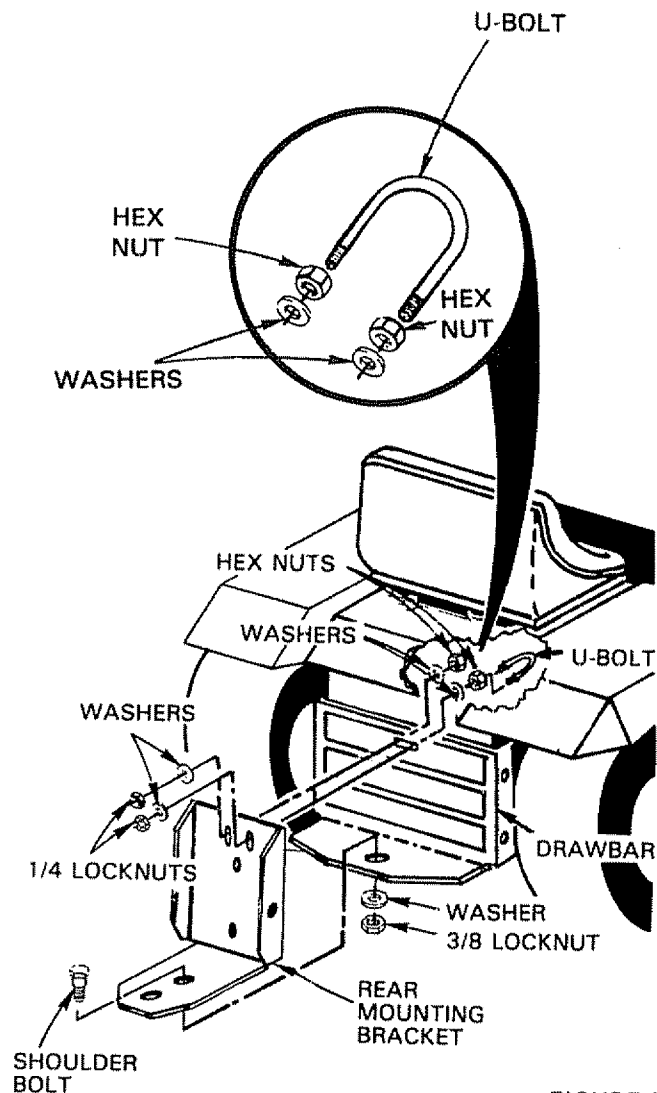
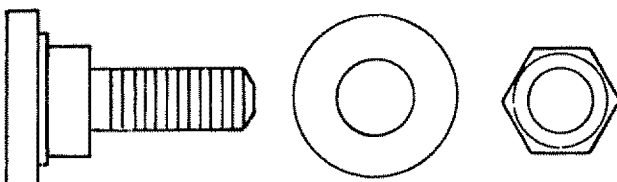

FIGURE 9

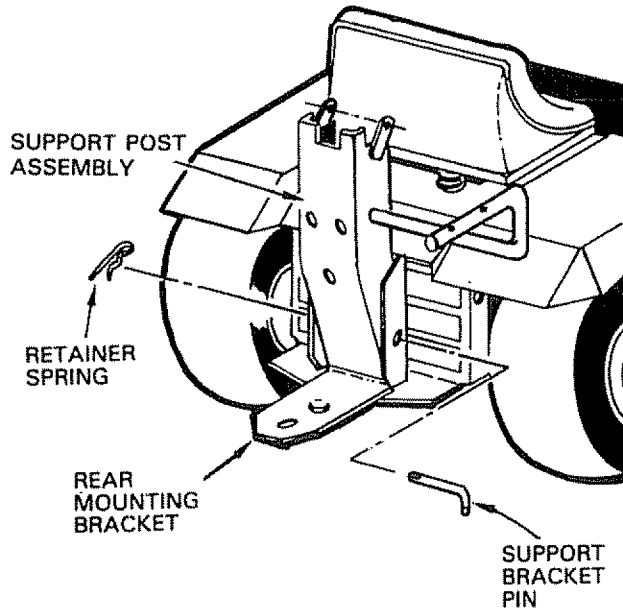
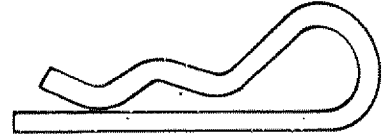

FIGURE 10

5. Assemble the support post assembly to the rear mounting bracket (Fig. 10) using support bracket pin and retainer spring. Retainer spring shown full size below. Support post, latch pin and retainer spring furnished with bagger.



6. Install end plug (Fig. 11) on elbow support tube. End plug furnished with bagger.
7. Mount the elbow retainer and the elbow shield to the elbow support tube (Fig. 11) using: two formed washers and two 5/16 locknuts (shown full size below). NOTE: Do not tighten. Elbow retainer, elbow shield and hardware furnished with bagger.

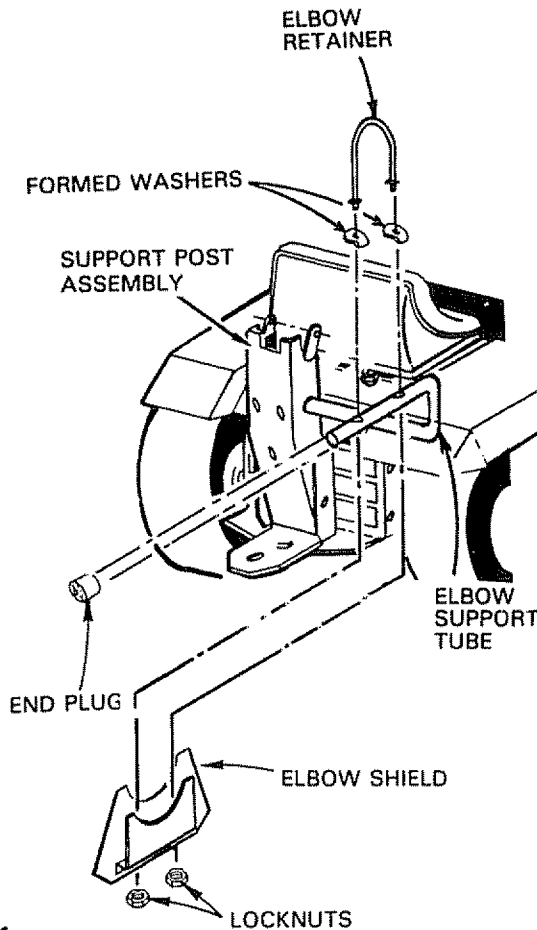
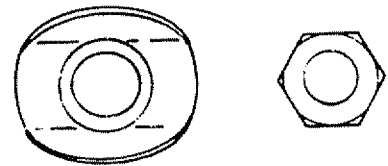

FIGURE 11

8. Locate the small hole in one end of the elbow. Slide this end of the elbow through elbow retainer (Fig. 12 - Inset). Secure elbow to elbow retainer using: one clip, one screw, two washers, and one acorn nut. NOTE: Mount clip in hole located 2 - 1/2" from edge of elbow. Hardware shown full size below. Head of screw and one flat washer mount to the inside of elbow. Position clip with closed end facing tube opening as shown in Fig. 12 - Inset. Tighten securely. NOTE: Tighten hardware assembled in step 7. Elbow and hardware furnished with grass catcher.



9. Flip seat forward.

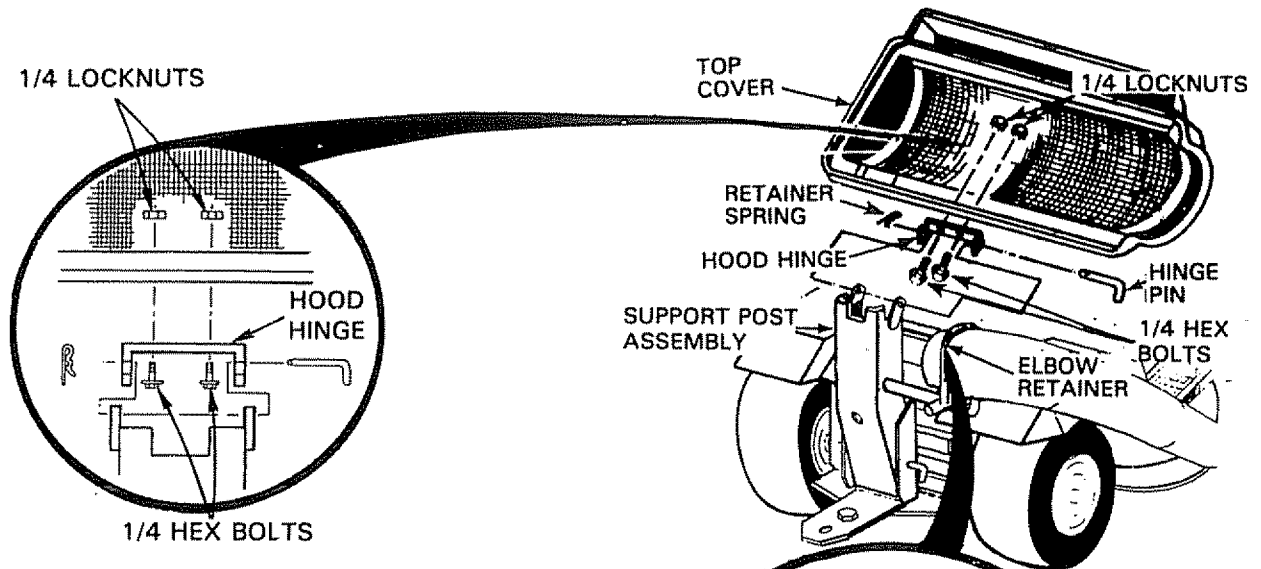
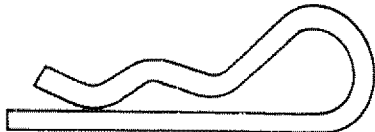

FIGURE 12

10. Mount hood hinge to grass catcher cover using (2) 1/4 hex bolts and (2) 1/4 locknuts (shown full size below) (Fig. 12 - upper inset).



11. Mount top cover to support post (Fig. 12) using latch pin and retainer spring. Retainer spring shown full size below. Latch pin and retainer spring furnished with grass catcher.



12. Position the grass catcher container assemblies onto the support posts through the "L" slots (Fig. 13 - Inset).

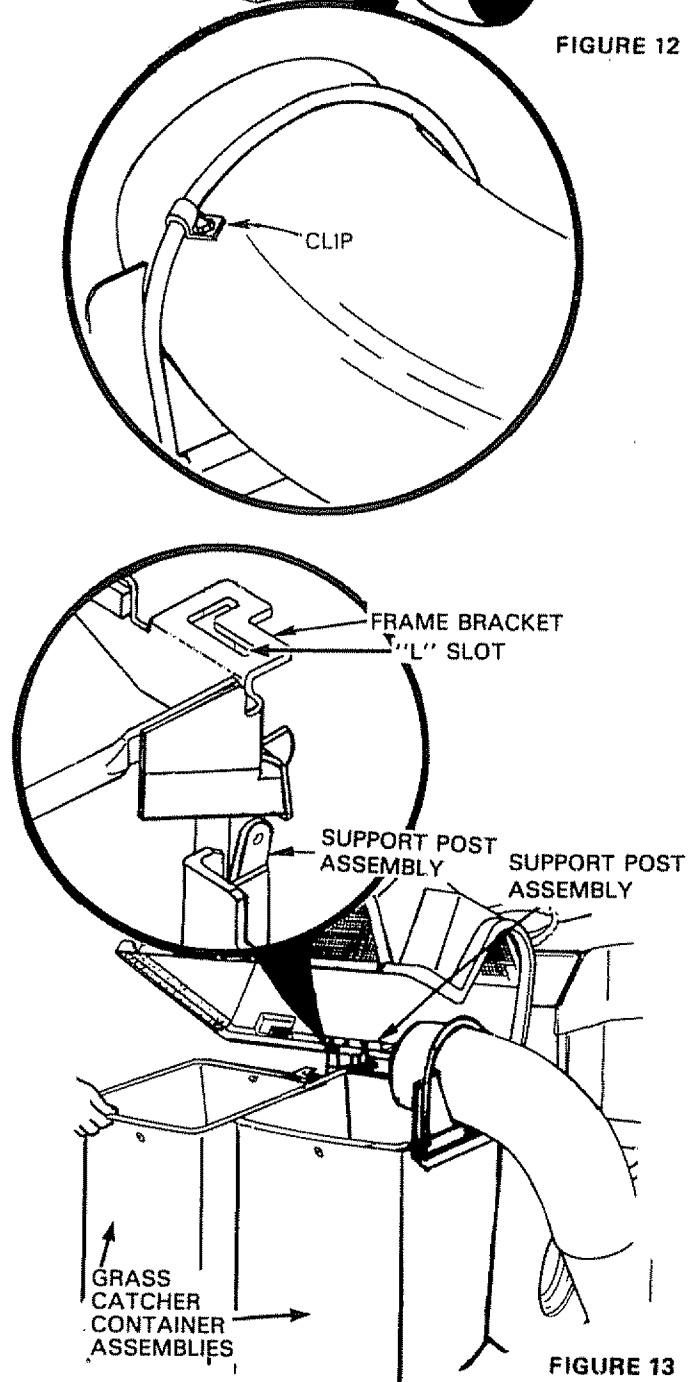

FIGURE 13

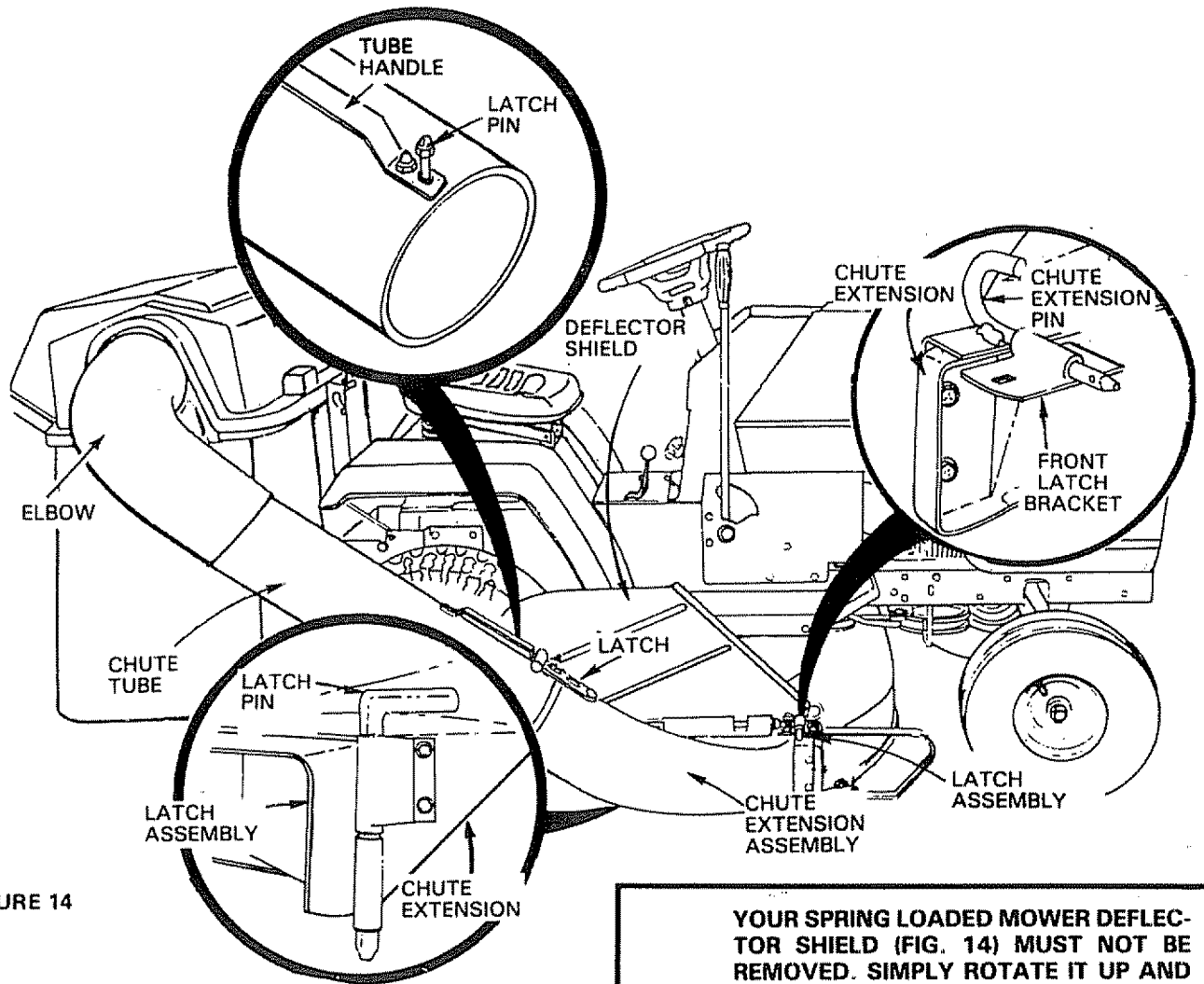

FIGURE 14

**YOUR SPRING LOADED MOWER DEFLECTOR SHIELD (FIG. 14) MUST NOT BE REMOVED. SIMPLY ROTATE IT UP AND HOLD IN UP POSITION WHILE ATTACHING CHUTE EXTENSION. THE MOWER DEFLECTOR SHIELD CAN BE RELEASED TO REST AGAINST CHUTE EXTENSION. THIS WILL ASSURE DEFLECTOR SHIELD IS STILL ON MOWER IF CHUTE EXTENSION OF GRASS CATCHER ATTACHMENT IS REMOVED.**

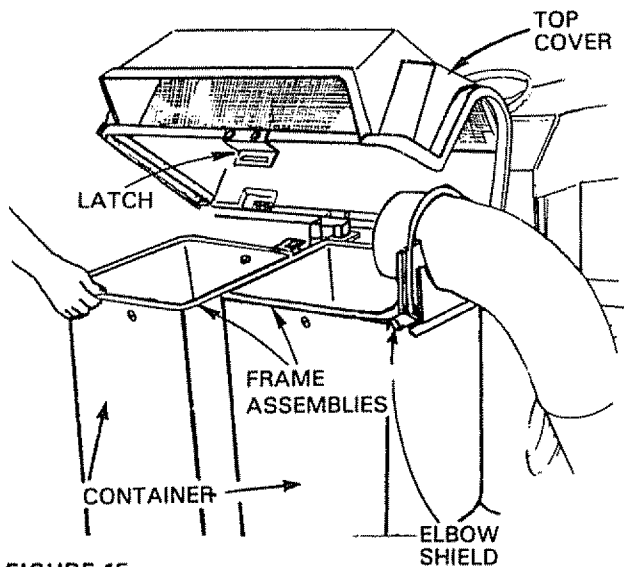
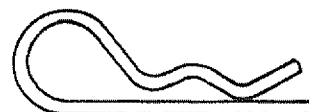
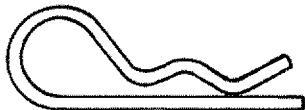

FIGURE 15

13. Assemble chute extension to mower housing.
  - a. Remove cardboard insert from rectangular opening.
  - b. Insert chute extension pin into front latch bracket (Fig. 14 - R.H. Inset).
  - c. Lift up slightly on L.H. side of chute extension lining up spacer located on latch assembly with rear latch bracket (Fig. 14).
  - d. Secure R.H side of chute extension to front latch bracket using: retainer spring (shown full size below). Chute extension and retainer spring furnished with grass catcher.



- e. Secure L.H. side of chute extension to latch assembly using: latch pin and retainer spring (Fig. 14 - Lower Inset). Retainer spring shown full size below. Latch pin and retainer spring furnished with grass catcher.



14. Place chute tube (Fig. 14) in elbow. Slide chute tube over chute extension (Fig. 14) and secure by hooking latch over latch pin (Fig. 14 - Upper Inset).  
15. Close top cover. NOTE: Be sure elbow shield is on inside of top cover (Fig. 14).

## OPERATION



**CONNECT SPARK PLUG WIRE(S) TO SPARK PLUG(S). BE CAREFUL TO AVOID TOUCHING HOT MUFFLER OR ENGINE COMPONENTS.**

Follow the mower operation instructions in your tractor owners manual.

When operating your grass catcher on a lawn where grass and leaf bagging equipment has not been used, you are picking up thatch and debris that has accumulated for long periods of time. The amount collected and the total time of operation may be greater than you will experience with regular use of your grass catcher.



**DO NOT OPERATE MOWER WITH GRASS CATCHER ASSEMBLY PARTIALLY INSTALLED.**

## TIPS FOR IMPROVED BAGGING OPERATION:

1. Place throttle control at full throttle.
2. Select a gear low enough to give good mower cutting performance, good quality cut and good bagging performance. NOTE: It may be necessary to overlap width of cut to suit your conditions.

### VIEW FROM TOP---TOP COVER OPEN

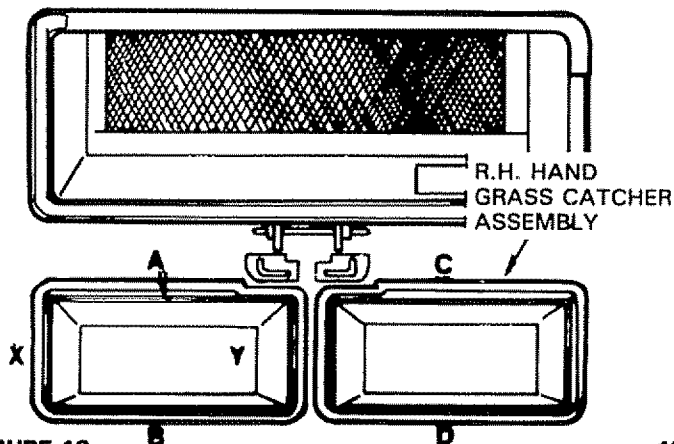

FIGURE 16

3. If grass is extremely tall, it should be mowed twice. The first time relatively high, the second time to desired height. NOTE: Use L.H. side of mower for trimming.
4. Plastic lawn bags can be inserted inside grass catcher containers for ease of debris disposal.



**DISENGAGE MOWER WHEN CROSSING GRAVEL SURFACES AND ANY CONDITIONS WHERE THROWN OBJECTS COULD BE A HAZARD.**

**DO NOT ATTEMPT TO VACUUM UP CANS OR OTHER POTENTIALLY HAZARDOUS PROJECTILES.**

5. Avoid cutting wet grass or in the morning while the dew is still heavy. Grass clippings collected under these conditions tend to be sticky and adhere to the walls of the flow path causing clogging.
6. Keep clear grass catcher chute tube clean so that clogging can be detected.



**DISENGAGE BLADES AND STOP ENGINE BEFORE OPENING COVER.**

**INSTALL CONTAINERS BEFORE OPERATING.**

**CLOSE COVER BEFORE STARTING MOWER.**

**KEEP CLEAR GRASS CATCHER CHUTE TUBE CLEAN TO DETECT CLOGGING. IF CLOGGING OCCURS, DISENGAGE BLADES, SHIFT INTO NEUTRAL, ENGAGE THE PARKING BRAKE AND SHUT OFF THE ENGINE BEFORE REMOVING TUBE TO CLEAR OBSTRUCTION.**

If the grass catcher fails to pick up cut grass or leaves, it is an indication that clogging has occurred in the system (See Step 1 below) or that the grass catcher containers are full (See step 2 below).

1. Stop tractor and mower and remove clogged grass. Refer to "Caution" above.
  2. Disengage blades, shift into neutral, engage the parking brake and stop the engine.
    - a. Unlatch cover (Fig. 15).
    - b. Remove L.H. grass catcher assembly. Stand at position "X" and grasp grass catcher at points "A" and "B" and lift off (Fig. 16).
    - c. After removing L.H. assembly, stand at position "Y", grasp R.H. catcher assembly at points "C" and "D" and lift off. Reverse procedure to replace.
    - d. Close cover and latch.
- NOTE: If experiencing abnormal discharge when operating mower without grass catcher attachment it may be necessary to remove grass catcher blades.

## MAINTENANCE

For any adjustment, inspection or maintenance:

1. Push clutch-brake pedal completely into "BRAKE" position.
2. Move gear shift lever to "NEUTRAL" position.
3. Place parking brake in "ENGAGED" position. Raise parking brake lever and hold in "ENGAGED" position. Release clutch-brake pedal.
4. Move throttle control lever to "SLOW" position.
5. Disengage mower blade clutch lever.
6. Turn ignition key to "OFF" position.
7. Remove Key.

**MAKE ABSOLUTELY SURE THE BLADES AND ALL MOVING PARTS HAVE COMPLETELY STOPPED.**



**DISCONNECT THE SPARK PLUG WIRE(S) FROM THE SPARK PLUG(S) AND KEEP WIRE(S) AWAY FROM THE PLUG(S) TO PREVENT INJURY FROM ACCIDENTAL STARTING. BE CAREFUL TO AVOID TOUCHING HOT MUFFLER OR ENGINE COMPONENTS.**

## BLADE CARE

*To ensure satisfactory operation, it is recommended that before the start of each mowing season, the old blades be discarded and replaced with new blades. Blades can be purchased at all Sears Service Centers and most retail stores.*

## TO REMOVE GRASS CATCHER

Reverse steps 1 thru 15 under "Assembly - Grass Catcher", pages 7 - 11.



**YOUR CONTAINERS ARE OF VERY DURABLE MATERIAL, HOWEVER, IN THE EVENT OF EXCESSIVE WEAR OR DAMAGE, REPLACE IMMEDIATELY. THE REPLACEMENT CONTAINER SHOULD COMPLY WITH THE ORIGINAL MANUFACTURED SPECIFICATIONS IN ORDER TO INSURE PROPER PERFORMANCE AND PRODUCT SAFETY.**

## STORAGE

*When grass catcher is to be stored for a period of time, clean it thoroughly, remove all dirt, grass, leaves, etc. Store in a clean, dry place.*



**REPLACE IMMEDIATELY ANY PARTS THAT SHOW WEAR OR DETERIORATION, ESPECIALLY PARTS WHICH CONTAIN THE FLOW OF MATERIAL FROM THE MOWER. ALSO, CHECK THE CONDITION OF FASTENERS THAT KEEP THESE PARTS IN A SAFE POSITION DURING OPERATION.**



## **SERVICE NOTES**

# REPAIR PARTS

CRAFTSMAN GRASS CATCHER FOR SIDE DISCHARGE MOWER--MODEL NUMBER

917.249393

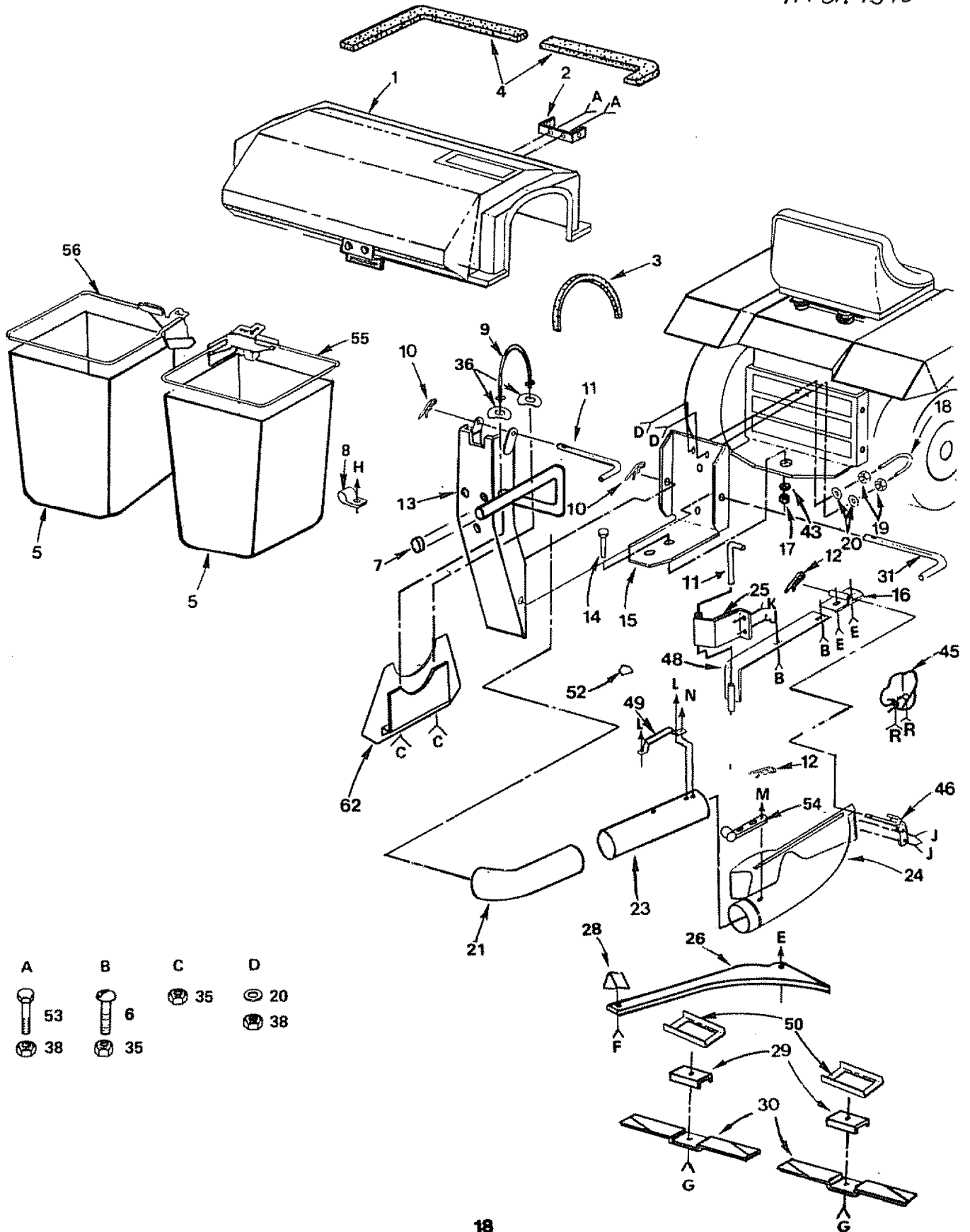

# REPAIR PARTS

## CRAFTSMAN GRASS CATCHER FOR SIDE DISCHARGE MOWER--MODEL NUMBER 917.249393

| KEY NO. | PART NO.   | DESCRIPTION                     | KEY NO. | PART NO.   | DESCRIPTION                          |
|---------|------------|---------------------------------|---------|------------|--------------------------------------|
| 1       | 110334X    | Cover - Top                     | 36      | 57734      | Washer, Formed                       |
| 2       | 86578      | Bracket - Hinge                 | 37      | 41945      | Screw - Truss Head 10-24 x 1/2       |
| 3       | 110441X    | Strip - Foam                    | 38      | STD541425  | * Nut - Lock 1/4 - 20                |
| 4       | 106815X    | Strip - Foam                    | 39      | STD533110  | * Bolt - Carriage 5/16 - 18 x 1      |
| 5       | 120176X    | Container - 30 Gal.             | 40      | 76507      | Washer 11/32                         |
| 6       | 66238      | Bolt - Carriage 5/16 - 18 x 5/8 | 41      | STD522512  | * Bolt - Hex, 1/4 - 20 x 1 - 1/4     |
| 7       | 104389X    | Plug - End                      | 42      | 85891      | Bolt - Hex, 3/8 - 24 x 1 - 3/4 Gr. 5 |
| 8       | 83553      | Clip - Elbow                    | 43      | 74316      | Washer .406 x 1 x .127/.112          |
| 9       | 86558      | Retainer - Elbow                | 44      | STD551137  | * Washer - Lock, 3/8                 |
| 10      | 85902      | Spring - Retainer               | 45      | 120101X    | Baffle - Chute                       |
| 11      | 120097X    | Pin - Latch                     | 46      | 85925      | Pin Assembly - Latch, Chute          |
| 12      | 85903      | Spring - Retainer               | 47      | STD523107  | * Bolt - Hex 5/16 - 18 x 3/4 Gr. 5   |
| 13      | 110254X363 | Post - Support                  | 48      | 120103X363 | Latch Assembly                       |
| 14      | 62361      | Bolt - Shoulder                 | 49      | 121109X    | Handle Assembly (Incl. Key # 61)     |
| 15      | 86562      | Bracket - Mounting              | 50      | 86987      | Saddle - Upper Blade                 |
| 16      | 120098X004 | Bracket Latch, Front            | 51      | STD551110  | * Washer - Lock #10                  |
| 17      | STD541437  | * Nut - Lock 3/8 - 16           | 52      | 85463      | Decal - Danger                       |
| 18      | 86626      | U-Bolt 1/4 - 20                 | 53      | 71615      | Bolt - Hex 1/4 - 20 x 3/4            |
| 19      | STD541025  | * Nut - Hex 1/4 - 20            | 54      | 109808X    | Latch                                |
| 20      | 85723      | Washer - Flat 9/32              | 55      | 120108X363 | Assembly - Frame, R.H.               |
| 21      | 110257X    | Elbow                           | 56      | 120109X363 | Assembly - Frame, L.H.               |
| 23      | 104415X    | Tube - Chute                    | 58      | 2029J      | Nut - Weld                           |
| 24      | 120100X    | Extension - Chute               | 59      | 12049      | Washer, Flat                         |
| 25      | 120102X004 | Latch Bracket - Chute, Rear     | 61      | 120203X    | Stud - Latch                         |
| 26      | 85937      | Baffle - R.H.                   | 62      | 110255X363 | Shield - Elbow                       |
| 28      | 85936      | Clamp                           | 64      | 60867      | Nut - Acorn #10 - 24                 |
| 29      | 85893      | Saddle - Lower Blade            | 65      | 120105X    | Screw - Plastite 1/4 - 10 x 3/4      |
| 30      | 104418X    | Blade - Lower                   | ---     | 104419X    | Bag - Trash, 30 Gal., 1.5 Mil.       |
| 31      | 86543      | Pin - Support Bracket           | ---     | 120094X    | Manual - Owners                      |
| 33      | 74291010   | Screw - Truss Head 10-24 x 5/8  |         |            |                                      |
| 35      | STD541431  | * Nut - Lock 5/16 - 18          |         |            |                                      |

\*STANDARD HARDWARE--PURCHASE LOCALLY

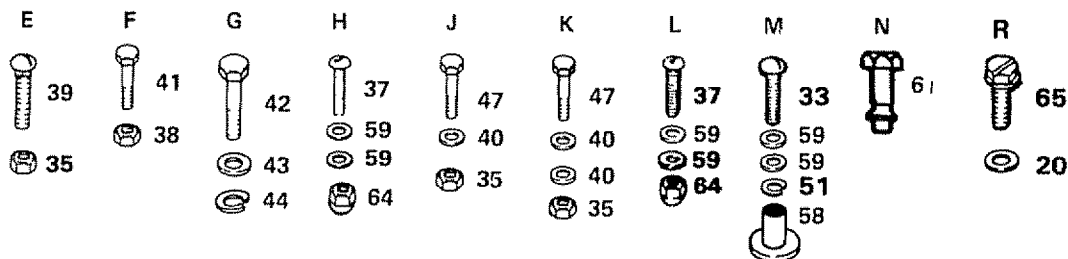

**SEARS  
OWNERS  
MANUAL**

**MODEL NO.  
917.249393**

**HOW TO ORDER  
REPAIR PARTS**

**CRAFTSMAN®  
GRASS CATCHER**

*The Model Number will be found on the Model Plate attached to the Support Post. Always provide the Model Number when requesting service or repair parts for your Craftsman Grass Catcher.*

*All parts listed herein may be ordered from any Sears Service Center/Departments and most Sears stores.*

**WHEN ORDERING REPAIR PARTS, ALWAYS GIVE THE FOLLOWING INFORMATION:**

- THE PART NUMBER
- THE PART DESCRIPTION
- THE MODEL NUMBER
- THE NAME OF MERCHANDISE

*Your Sears merchandise has added value when you consider Sears has service units nationwide staffed with Sears trained technicians having the parts, tools and the equipment to insure that we meet our pledge to you, "We Service What We Sell".*

*Sears, Roebuck and Co., Chicago, IL 60684 U.S.A.*