

SEARS

CRAFTSMAN®

MODEL NUMBER 917.258911 OWNER'S MANUAL

- Assembly
- Operation
- Customer Responsibilities
- Service and Adjustments
- Repair Parts

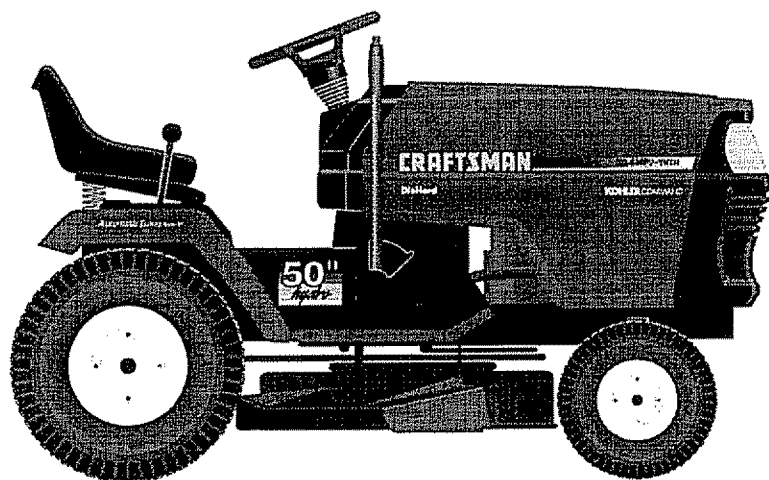

CAUTION: Read and follow all safety rules and instructions before operating this equipment.
FOR CONSUMER ASSISTANCE HOT LINE, CALL THIS TOLL FREE NUMBER 1-800-659-5917

Sears, Roebuck and Co., Hoffman Estates, IL 60179 U.S.A.



SAFETY RULES



Safe Operation Practices for Ride-On Mowers

IMPORTANT: THIS CUTTING MACHINE IS CAPABLE OF AMPUTATING HANDS AND FEET AND THROWING OBJECTS. FAILURE TO OBSERVE THE FOLLOWING SAFETY INSTRUCTIONS COULD RESULT IN SERIOUS INJURY OR DEATH.

I. GENERAL OPERATION

- Read, understand, and follow all instructions in the manual and on the machine before starting.
- Only allow responsible adults, who are familiar with the instructions, to operate the machine.
- Clear the area of objects such as rocks, toys, wire, etc., which could be picked up and thrown by the blade.
- Be sure the area is clear of other people before mowing. Stop machine if anyone enters the area.
- Never carry passengers.
- Do not mow in reverse unless absolutely necessary. Always look down and behind before and while backing.
- Be aware of the mower discharge direction and do not point it at anyone. Do not operate the mower without either the entire grass catcher or the guard in place.
- Slow down before turning.
- Never leave a running machine unattended. Always turn off blades, set parking brake, stop engine, and remove keys before dismantling.
- Turn off blades when not mowing.
- Stop engine before removing grass catcher or unclogging chute.
- Mow only in daylight or good artificial light.
- Do not operate the machine while under the influence of alcohol or drugs.
- Watch for traffic when operating near or crossing roadways.
- Use extra care when loading or unloading the machine into a trailer or truck.

II. SLOPE OPERATION

Slopes are a major factor related to loss-of-control and tipover accidents, which can result in severe injury or death. All slopes require extra caution. If you cannot back up the slope or if you feel uneasy on it, do not mow it.

DO:

- Mow up and down slopes, not across.
- Remove obstacles such as rocks, tree limbs, etc.
- Watch for holes, ruts, or bumps. Uneven terrain could overturn the machine. *Tall grass can hide obstacles.*
- Use slow speed. Choose a low gear so that you will not have to stop or shift while on the slope.
- Follow the manufacturer's recommendations for wheel weights or counterweights to improve stability.
- Use extra care with grass catchers or other attachments. These can change the stability of the machine.
- Keep all movement on the slopes *slow* and *gradual*. Do not make sudden changes in speed or direction.
- Avoid starting or stopping on a slope. If tires lose traction, disengage the blades and proceed slowly *straight* down the slope.

DO NOT:

- *Do not* turn on slopes unless necessary, and then, turn slowly and gradually downhill, if possible.
- *Do not* mow near drop-offs, ditches, or embankments. The mower could suddenly turn over if a wheel is over the edge of a cliff or ditch, or if an edge caves in.
- *Do not* mow on wet grass. Reduced traction could cause sliding.
- *Do not* try to stabilize the machine by putting your foot on the ground.
- *Do not* use grass catcher on steep slopes.

III. CHILDREN

Tragic accidents can occur if the operator is not alert to the presence of children. Children are often attracted to the machine and the mowing activity. *Never* assume that children will remain where you last saw them.

- Keep children out of the mowing area and under the watchful care of another responsible adult.
- Be alert and turn machine off if children enter the area.
- Before and when backing, look behind and *down* for small children.
- Never carry children. They may fall off and be seriously injured or interfere with safe machine operation.
- Never allow children to operate the machine.
- Use extra care when approaching blind corners, shrubs, trees, or other objects that may obscure vision.

IV. SERVICE

- Use extra care in handling gasoline and other fuels. They are flammable and vapors are explosive.
 - Use only an approved container.
 - Never remove gas cap or add fuel with the engine running. Allow engine to cool before refueling. Do not smoke.
 - Never refuel the machine indoors.
 - Never store the machine or fuel container inside where there is an open flame, such as a water heater.
- Never run a machine inside a closed area.
- Keep nuts and bolts, especially blade attachment bolts, tight and keep equipment in good condition.
- Never tamper with safety devices. Check their proper operation regularly.
- Keep machine free of grass, leaves, or other debris build-up. Clean oil or fuel spillage. Allow machine to cool before storing.
- Stop and inspect the equipment if you strike an object. Repair, if necessary, before restarting.
- Never make adjustments or repairs with the engine running.
- Grass catcher components are subject to wear, damage, and deterioration, which could expose moving parts or allow objects to be thrown. Frequently check components and replace with manufacturer's recommended parts, when necessary.
- Mower blades are sharp and can cut. Wrap the blade(s) or wear gloves, and use extra caution when servicing them.
- Check brake operation frequently. Adjust and service as required.



Look for this symbol to point out important safety precautions. It means CAUTION!!! BECOME ALERT!!! YOUR SAFETY IS INVOLVED.



CAUTION: Always disconnect spark plug wire and place wire where it cannot contact spark plug in order to prevent accidental starting when setting up, transporting, adjusting or making repairs.

WARNING

The engine exhaust from this product contains chemicals known to the State of California to cause cancer, birth defects, or other reproductive harm.

CONGRATULATIONS on your purchase of a Sears Tractor. It has been designed, engineered and manufactured to give you the best possible dependability and performance.

Should you experience any problem you cannot easily remedy, please contact your nearest Sears Authorized Service Center/Department. We have competent, well-trained technicians and the proper tools to service or repair this tractor.

Please read and retain this manual. The instructions will enable you to assemble and maintain your tractor properly. Always observe the "SAFETY RULES".

MODEL NUMBER	917.258911
SERIAL NUMBER	_____
DATE OF PURCHASE	_____
THE MODEL AND SERIAL NUMBERS WILL BE FOUND ON A PLATE UNDER THE SEAT.	
YOU SHOULD RECORD BOTH SERIAL NUMBER AND DATE OF PURCHASE AND KEEP IN A SAFE PLACE FOR FUTURE REFERENCE.	

MAINTENANCE AGREEMENT

A Sears Maintenance Agreement is available on this product. Contact your nearest Sears store for details.

CUSTOMER RESPONSIBILITIES

- Read and observe the safety rules.
- Follow a regular schedule in maintaining, caring for and using your tractor.
- Follow the instructions under "Customer Responsibilities" and "Storage" sections of this owner's manual.

PRODUCT SPECIFICATIONS

HORSEPOWER:	22.5
GASOLINE CAPACITY AND TYPE:	3.5 GALLONS UNLEADED REGULAR
OIL TYPE (API-SF/SG/SH):	SAE 10W30 (above 32°F) SAE 5W-30 (below 32°F)
OIL CAPACITY:	W/ FILTER: 4.2 PINTS W/O FILTER: 3.7 PINTS
SPARK PLUG: (GAP: .030")	CHAMPION RC12YC
VALVE CLEARANCE:	NOT ADJUSTABLE
GROUND SPEED (MPH):	FORWARD: 0 - 5.8 REVERSE: 0 - 2.1
TIRE PRESSURE:	FRONT: 14 PSI REAR: 10 PSI
CHARGING SYSTEM:	15 AMPS @ 3600 RPM
BATTERY:	AMP/HR: 35 MIN. CCA: 280 CASE SIZE: U1R
BLADE BOLT TORQUE:	30-35 FT. LBS.

WARNING: This tractor is equipped with an internal combustion engine and should not be used on or near any unimproved forest-covered, brush-covered or grass-covered land unless the engine's exhaust system is equipped with a spark arrester meeting applicable local or state laws (if any). If a spark arrester is used, it should be maintained in effective working order by the operator.

In the state of California the above is required by law (Section 4442 of the California Public Resources Code). Other states may have similar laws. Federal laws apply on federal lands. A spark arrester for the muffler is available through your nearest Sears Authorized Service Center/Department (See REPAIR PARTS section of this manual).

LIMITED TWO YEAR WARRANTY ON CRAFTSMAN RIDING EQUIPMENT

For two (2) years from the date of purchase, if this Craftsman Riding Equipment is maintained, lubricated and tuned up according to the instructions in the owner's manual, Sears will repair or replace, free of charge, any parts found to be defective in material or workmanship.

This Warranty does not cover:

- Expendable items which become worn during normal use, such as blades, spark plugs, air cleaners, belts, etc.
- Tire replacement or repair caused by punctures from outside objects, such as nails, thorns, stumps, or glass.
- Repairs necessary because of operator abuse, negligence, improper storage or accident or the failure to maintain the equipment according to the instructions contained in the owner's manual.
- Riding equipment used for commercial or rental purposes.

LIMITED 90 DAY WARRANTY ON BATTERY

For ninety (90) days from date of purchase, if any battery included with this riding equipment proves defective in material or workmanship and our testing determines the battery will not hold a charge, Sears will replace the battery at no charge.

IN-HOME WARRANTY SERVICE ON YOUR CRAFTSMAN RIDING EQUIPMENT IS AVAILABLE AT NO-CHARGE FOR 30 DAYS FROM THE DATE OF PURCHASE. PLEASE CONTACT YOUR NEAREST SERVICE CENTER. AFTER 30 DAYS FROM THE DATE OF PURCHASE, WARRANTY SERVICE IS AVAILABLE BY TAKING YOUR CRAFTSMAN RIDING EQUIPMENT TO YOUR NEAREST SEARS SERVICE CENTER. (IN-HOME WARRANTY SERVICE WILL STILL BE AVAILABLE AFTER 30 DAYS FROM THE DATE OF PURCHASE BUT A STANDARD TRIP CHARGE WILL APPLY.) THIS WARRANTY APPLIES ONLY WHILE THIS PRODUCT IS IN THE UNITED STATES.

This Warranty gives you specific legal rights, and you may also have other rights which may vary from state to state.

SEARS, ROEBUCK AND CO., D/817 WA, HOFFMAN ESTATES, IL 60179

TABLE OF CONTENTS

SAFETY RULES	2	MAINTENANCE SCHEDULE	17
PRODUCT SPECIFICATIONS	3	SERVICE AND ADJUSTMENTS	21-27
CUSTOMER RESPONSIBILITIES	3, 16-19	STORAGE	28
WARRANTY	3	TROUBLESHOOTING	29-30
TRACTOR ACCESSORIES	5,15	REPAIR PARTS - TRACTOR	32-50
ASSEMBLY	7-10	REPAIR PARTS - ENGINE	51-58
OPERATION	12-16	PARTS ORDERING/SERVICE	BACK COVER

INDEX

A		E			
Accessories	5	Electrical:		Operation	12-16
Adjustments:		Interlocks and Relays	26	Operating Mower	14
Brake	23	Schematic	31	Options:	
Carburetor	27	Wiring Diagram	32	Accessories	5
Clutch Pulley	23	Engine:		Spark Arrester	3,40
Gauge Wheels	14	Air Filter	20	P	
Mower		Air Screen	19	Parking Brake	13
Front-To-Back	22	Cooling Fins	20	Parts Bag	6
Side-To-Side	21	Oil Change	19	Parts, Replacement/Repair	32-50
Throttle Control Cable	27	Oil Level	15	Product Specifications	3
Oil Type	15,19	Oil Type	15,19	R	
Preparation	15	Preparation	15	Repair Parts	32-50
Repair Parts	51-58	Repair Parts	51-58	S	
Starting	15-16	Starting	15-16	Safety Rules	2
Storage	28	Storage	28	Seat	8
B		F		Service and Adjustments	21-27
Battery:		Filter:		Carburetor	27
Charging	8	Air Filter	20	Clutch Pulley	23
Cleaning	20	Fuel	20	Fuse	26
Starting with Weak Battery	25	Oil	20	Hood Removal/Installation	26
Storage	28	Fuel:		Motion Drive Belt	
Terminals	19	Storage	28	Removal/Replacement	22
Belt:		Type	15	Mower Drive Belt	
Motion Drive		Fuse	26	Removal/Replacement	22
Removal/Replacement	24	H		Removal/Replacement	22
Mower Drive		Headlights	26	Mower Blade Drive Belt	
Removal/Replacement	22	Hood Removal/Installation	26	Removal/Replacement	23
Mower Blade Drive		L		Mower Adjustment	
Removal/Replacement	23	Leveling Mower Deck	22	Front-to-Back	22
Blade:		Lubrication:		Side-to-Side	21
Sharpening	18	Chart	17	Mower Removal/Installation	21
Replacement	18	Engine	19	Tire Care	8,16,25
Brake Adjustment	23	M		Slope Guide Sheet	59
C		Maintenance Schedule	17	Spark Plug(s)	20
Carburetor Adjustment	27	Mower:		Specifications	3
Clutch Pulley	23	Adjustment, Front-to-Back	22	Starting the Engine	15-16
Controls, Tractor	12	Adjustment, Side-to-Side	21	Steering Wheel	7,24
Customer Responsibilities	17-20	Blade Replacement	18	Stopping the Tractor	13
Engine:		Blade Sharpening	18	Storage	28
Air Filter	20	Cutting Height	13	T	
Air Screen	19	Installation	21	Throttle Control Cable Adjustment	27
Cooling Fins	20	Operation	14	Tires	8,18,25
Engine Oil	15,19	Removal	21	Troubleshooting Chart	29-30
Fuel Filter	20	Mowing Tips	16	Transaxle	19
Spark Plug(s)	20	Muffler	20	W	
Tractor:		Spark Arrester	3,40	Warranty	3
Battery	18	O		Wiring Diagram	32
Blade	18	Oil:		Wiring Schematic	31
Lubrication Chart	17	Cold Weather Conditions	15,19		
Maintenance Schedule	17	Engine	19		
Tire Care	8,18,25	Storage	28		
Transaxle	19				
Cutting Height, Mower	13				

ACCESSORIES AND ATTACHMENTS

These accessories and attachments were available through most Sears retail outlets and service centers when the tractor was purchased. Most Sears stores can order these items for you when you provide the model number of your tractor.

ENGINE

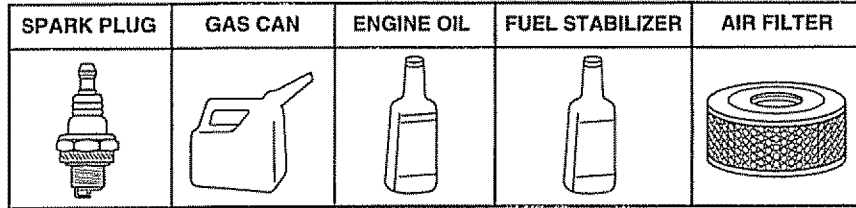

MAINTENANCE

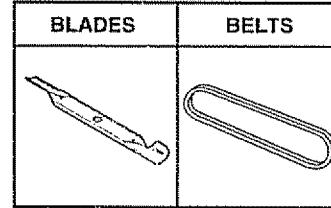

PERFORMANCE

Sears offers a wide variety of attachments that fit your tractor. Many of these are listed below with brief explanations of how they can help you. This list was current at the time of publication; however, it may change in future years - more attachments may be added, changes may be made in these attachments, or some may no longer be available or fit your model. **Contact your nearest Sears store for the accessories and attachments that are available for your tractor.**

Most of these attachments do not require additional hitches or conversion kits (those that do are indicated) and are designed for easy attaching and detaching.

AERATOR promotes deep root growth for a healthy lawn. Tapered 2.5-inch steel spikes mounted on 10-inch diameter discs puncture holes in soil at close intervals to let moisture soak in. Steel weight tray for increased penetration.

BUMPER protects front end of tractor from damage.

CARTS make hauling easy. Variety of sizes available, plus accessories such as side panel kits, tool caddy, cart cover, protective mat and dolly.

CORING AERATOR takes small plugs out of soil to allow moisture and nutrients to reach grass roots. 36-inch swath. 24 hardened steel coring tips. 150 lb. capacity weight tray.

DISC HARROW has 2 gangs of 4 steel blades that angle from 10 to 20 degrees, 40 inches wide. Can hook 2 units in tandem. (Requires sleeve hitch.)

DOZER BLADE removes snow; grades dirt, sand and gravel. 48 inches wide, 17 inches high, clears 44-inch path when angled. Master lift control lever for operator ease. Spring trip for snow removal on uneven pavement; built-in float for blade to follow ground contour. Reversible, replaceable scraper bar. (Use with tire chains and wheel weights and/or rear drawbar weight.)

EASY OIL DRAIN VALVE makes oil changes easier, faster.

FRONT NOSE ROLLER canters in front of mower deck to reduce chances of "scalping" on uneven terrain.

GANG HITCH lets you tow 2 or 3 pull-behind attachments at once, such as sweepers, dethatchers, aerators (not for use with rollers, carts or other heavy attachments).

MULCH RAKE/DETHATCHER loosens soil and flips thatch and matted leaves to lawn surface for easy pickup. Twenty spring tine teeth. Useful to prepare bare areas for seeding. Available for front or rear mounting. **HIGH PERFORMANCE REEL-ACTION SPRING TINE DETHATCHER** covers 36-inch wide path and tosses thatch into large hopper. Mounts behind tractor.

PLOW turns soil 6 inches deep, cuts 10-inch furrow. Crank adjustment controls depth, 3-position yoke sets width. Heavy steel landside for straight furrowing. (Requires sleeve hitch.)

RAMP TOPS AND FEET let you load and unload tractor from a pickup truck. Use with 2 x 8 or 2 x 10 lumber.

REAR GRADER BLADE is 42 inches wide and operated from driver's seat. Reversible steel blade can be angled at 30 degrees for grading. Reverses for pushing snow backwards. (Requires sleeve hitch.)

ROLLER for smoother lawn surface. 36-inch wide, 18-inch diameter water-tight drum holds up to 390 lbs. of weight. Rounded edges prevent harm to turf. Adjustable scraper automatically cleans drum.

SLEEVE CULTIVATOR is 43 inches wide. Prepares ground for seeding, helps weed control. Steel frame holds 5 adjustable sweeps. Adjusts vertically, horizontally. (Requires sleeve hitch.) **Optional accessory:** steel furrow opener for wider openings for potatoes, corn, and other deep-seeded crops.

SLEEVE HITCH for use with master lift system. Single pin couples/uncouples.

SNOWTHROWER has 42-inch swath. Drum-type auger handles powdery and wet/heavy snow. Mounts easily with simple pin arrangement. Discharge chute adjusts from tractor seat. 6-inch diameter spout discharges snow 10 to 50 feet. Lift controlled at tractor seat. (Use with chains and wheel weights and/or rear drawbar weight.)

SPRAYERS use 12-volt DC electric motor that connects to the tractor battery or other 12-volt source. Includes booms for automatic spraying and hand held wand for spot spraying. Wand has adjustable spray pattern. For applying herbicides, insecticides, fungicides and liquid fertilizers.

SPREADER/SEEDERS make seeding, fertilizing, and weed killing easy. Broadcast spreaders are also useful for granular de-icers and sand.

SWEEPERS let you collect grass clippings and leaves.

TILLER has 8 hp engine to prepare seed beds, cultivate, and compost garden residue. Chain-drive transmission. Six 11-inch diameter one piece heat-treated steel tines. Tills 30-inch path. (Requires sleeve hitch.) Or use 5 hp tow-behind **TILLER** with 36-inch swath to prepare seed beds, cultivate and compost garden residue. Tiller has its own built-in lift and depth control system and does NOT require a sleeve hitch. Fits any lawn, yard or garden tractor. Simply hook up to the tractor drawbar and go! **Optional accessories** for 5 hp tiller convert unit for dethatching, aerating, hilling...without tools.

TIRE CHAINS are heavy duty; closely spaced extra-large cross links give smooth ride, outstanding traction.

TRACTOR CAB has heavy duty vinyl fabric over tubular steel frame, ABS plastic top; clear plastic windshield offers 360 degree visibility. Hinged metal doors with catch. Keeps operator warm and dry. Remove vinyl sides and windshields for use as sun protector in summer. **Optional accessories include:** tinted/tempered solid safety glass windshield with hand operated wiper; 12-volt amber caution light for mounting on cab top.

VACS for powerful collection of heavy grass clippings and leaves. **Optional wand attachment** to pick up debris in hard-to-reach places. **VAC/CHIPPER** includes a chipper-shredder.

WEIGHT BRACKET for drawbar for snow removal applications. Can be mounted on front of tractor for plowing applications. Uses (1) 55 lb. weight.

WHEEL WEIGHTS for rear wheels provide needed traction for snow removal or dozing heavy materials.

CONTENTS OF HARDWARE PACK

Parts Bag contents shown

(4) Washers 3/8 x 3/4 x 14 Ga.

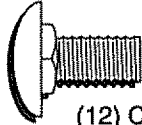

(12) Carriage Bolts
5/16-18 x 5/8

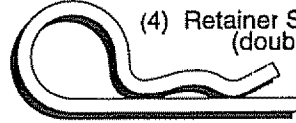

(4) Retainer Springs
(double loop)

(4) Brackets

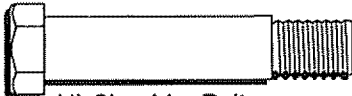
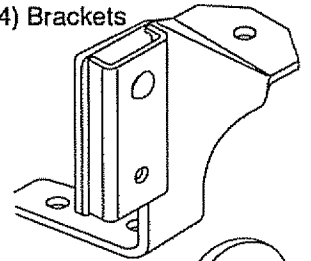

(4) Shoulder Bolt

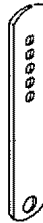

(4) Adjusting Bar

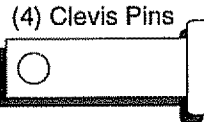

(4) Clevis Pins

(4) Wheels

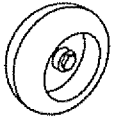

(12) Crownlock Nuts 3/16 x 8



(4) Locknut 3/8-16

(1) Shoulder Bolt
5/16-18

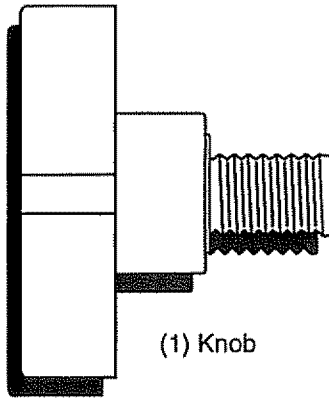
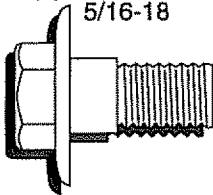

(1) Knob

(1) Washer 17/32 x 1-3/16 x 12 Gauge

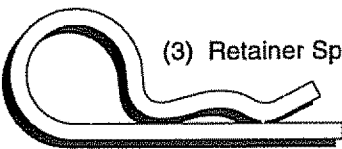
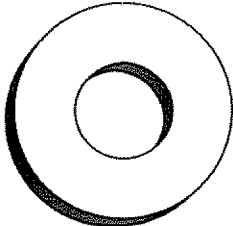

(3) Retainer Springs (double loop)

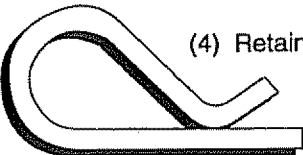

(4) Retainer Springs (single loop)

(2) Hex Bolts 1/4-20 x 3/4

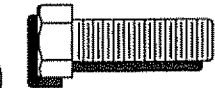

(2) Washers
9/32 x 5/8 x 16 Ga.

(2) Hex Nuts
1/4-20



(2) Lock Washers 1/4

Parts packed separately in carton

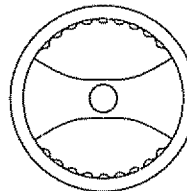

Steering Wheel



Steering Sleeve

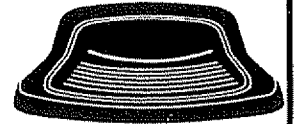

Seat

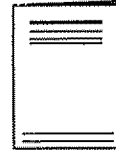

Manual

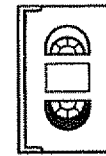

Video Cassette

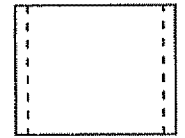

Parts Bag

Parts bag contents not shown full size

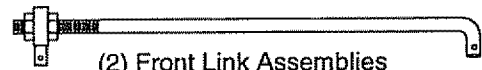

(2) Front Link Assemblies

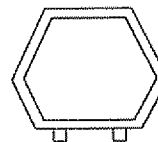

Steering Wheel Insert

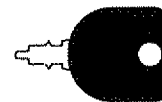

(2) Keys

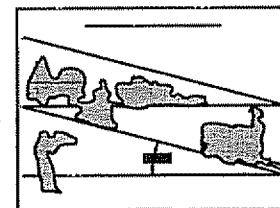

Slope Sheet

ASSEMBLY

Your new tractor has been assembled at the factory with the exception of those parts left unassembled for shipping purposes. To ensure safe and proper operation of your tractor all parts and hardware you assemble must be tightened securely. Use the correct tools as necessary to insure proper tightness.

TOOLS REQUIRED FOR ASSEMBLY

A socket wrench set will make assembly easier. Standard wrench sizes are listed.

- (2) 7/16" wrenches
- (1) 1/2" wrench
- (1) 9/16" wrench
- (1) 3/4" socket with drive ratchet
- Tire pressure gauge
- Utility knife

When right or left hand is mentioned in this manual, it means when you are in the operating position (seated behind the steering wheel).

TO REMOVE TRACTOR FROM CARTON

UNPACK CARTON

- Remove all accessible loose parts and parts cartons from carton (See page 6).
- Cut, from top to bottom, along lines on all four corners of carton, and lay panels flat.
- Check for any additional loose parts or cartons and remove.

BEFORE ROLLING TRACTOR OFF SKID

ATTACH STEERING WHEEL (See Fig. 1)

- Remove hex bolt, lock washer and large flat washer from steering shaft.
- Position front wheels of the tractor so they are pointing straight forward.
- Slide steering sleeve over steering shaft.
- Position steering wheel so cross bars are horizontal (left to right) and slide onto steering wheel adapter.
- Secure steering wheel to steering shaft with hex bolt, lock washer and large flat washer previously removed. Tighten securely.
- Snap steering wheel insert into center of steering wheel.
- Remove protective materials from tractor hood and grill.

IMPORTANT: CHECK FOR AND REMOVE ANY STAPLES IN SKID THAT MAY PUNCTURE TIRES WHERE TRACTOR IS TO ROLL OFF SKID.

TO ROLL TRACTOR OFF SKID (See Operation section for location and function of controls)

- Press lift lever plunger and raise attachment lift lever to its highest position.
- Release parking brake by depressing clutch/brake pedal.
- Place freewheel control in freewheeling position to disengage transmission (See "TO TRANSPORT" in the Operation section of this manual).
- Roll tractor forward off skid.
- Remove mower and packing materials.
- Remove ties from V-belts.

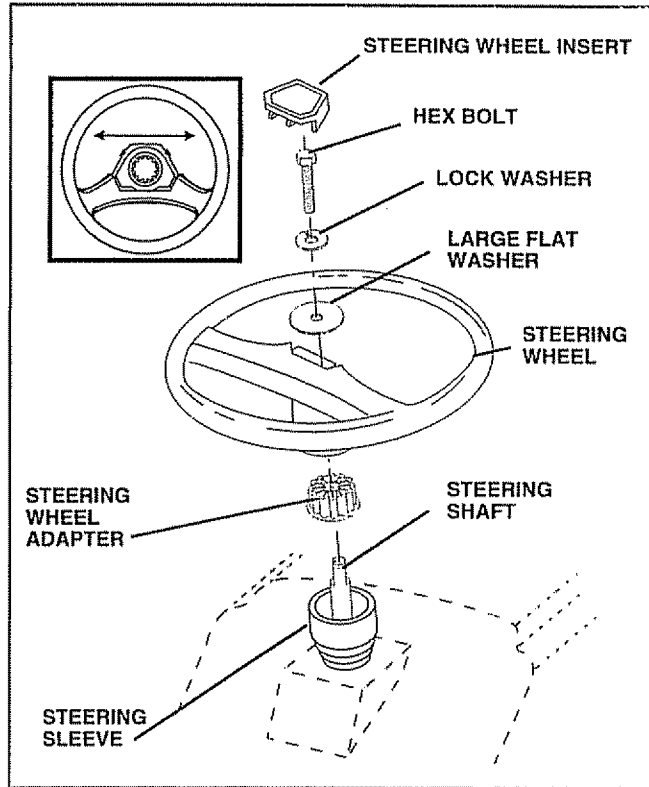

FIG. 1

HOW TO SET UP YOUR TRACTOR

CONNECT BATTERY (See Fig. 2)



CAUTION: Do not short battery terminals by allowing a wrench or any other object to contact both terminals at the same time. Before connecting battery, remove metal bracelets, wristwatch bands, rings, etc.

Positive terminal must be connected first to prevent sparking from accidental grounding.

- Lift hood to raised position.
- Open terminal access doors, remove terminal protective caps and discard.
- If this battery is put into service after month and year indicated on label (label located between terminals) charge battery for minimum of one hour at 6-10 amps.
- First connect RED battery cable to positive (+) battery terminal with hex bolt, flat washer, lock washer and hex nut as shown. Tighten securely.
- Connect BLACK grounding cable to negative (-) battery terminal with remaining hex bolt, flat washer, lock washer and hex nut. Tighten securely.
- Close terminal access doors.

ASSEMBLY

Use terminal access doors for:

- Inspection for secure connections (to tighten hardware).
- Inspection for corrosion.
- Testing battery.
- Jumping (if required).
- Periodic charging.

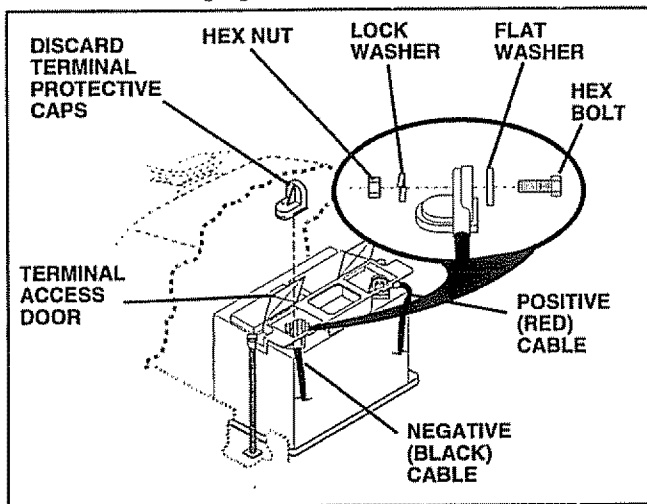

FIG. 2

INSTALL SEAT (See Fig. 3)

Adjust seat before tightening adjustment knob.

- Remove cardboard packing on seat pan.
- Place seat on seat pan and assemble shoulder bolt. Tighten shoulder bolt securely.
- Assemble adjustment knob and flat washer loosely. Do not tighten.
- Lower seat into operating position and sit on seat.
- Slide seat until a comfortable position is reached which allows you to press clutch/brake pedal all the way down.
- Get off seat without moving its adjusted position.
- Raise seat and tighten adjustment knob securely.

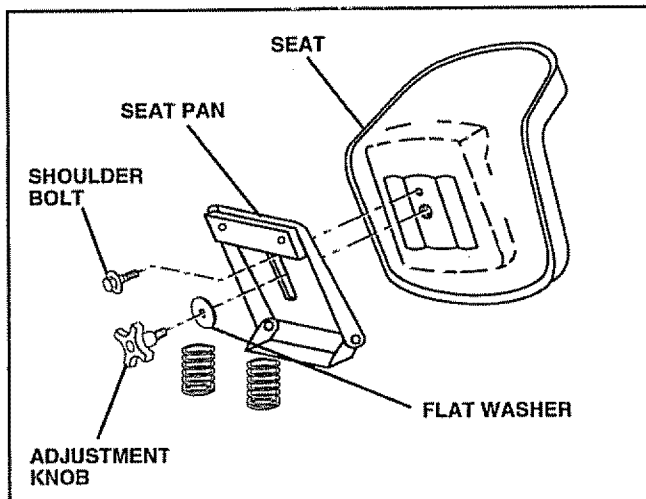

FIG. 3

CHECK TIRE PRESSURE

The tires on your tractor were overinflated at the factory for shipping purposes. Correct tire pressure is important for best cutting performance.

- Reduce tire pressure to PSI shown in "PRODUCT SPECIFICATIONS" on page 3 of this manual.

CHECK BRAKE SYSTEM

After you learn how to operate your tractor, check to see that the brake is properly adjusted. See "TO ADJUST BRAKE" in the Service and Adjustments section of this manual.

ASSEMBLE GAUGE WHEELS AND BRACKETS TO MOWER DECK (See Fig. 4)

The gauge wheels are designed to keep the mower deck in proper position when operating mower. Be sure they are properly adjusted to ensure optimum mower performance.

- Attach front gauge wheel brackets marked front left (FL), front right (FR) to mower deck using (3) carriage bolts and (3) locknuts. For ease of installation do not tighten locknuts until all carriage bolts have been installed.
- Attach rear gauge wheel brackets marked rear left (RL), rear right (RR) to mower deck using (3) carriage bolts and (3) locknuts. For ease of installation do not tighten locknuts until all carriage bolts have been installed.
- Slide gauge wheel bar down into bracket channel. Be sure that gauge wheel bar aligning holes are on top. Assemble gauge wheels as shown using shoulder bolts, 3/8 washers and 3/8-16 center locknuts and tighten securely.
- Adjust gauge wheels to highest position for ease of mower deck assembly.
- Adjust gauge wheels before operating mower as shown in the operation section of this manual.

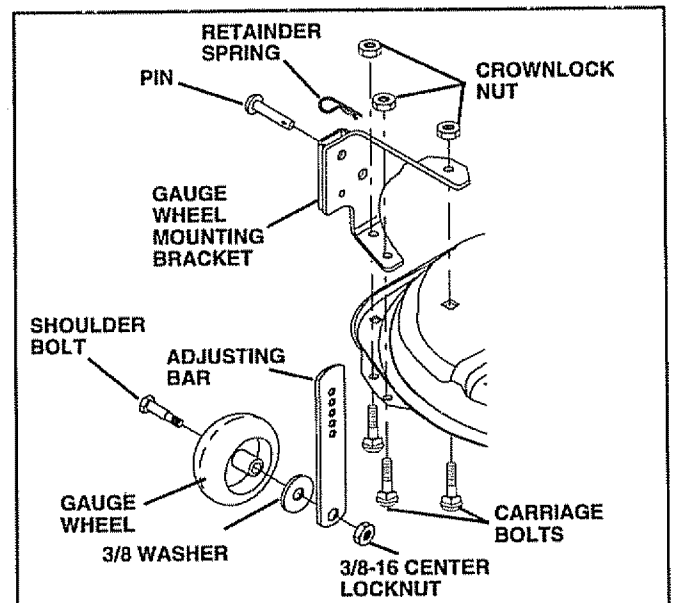

FIG. 4

ASSEMBLY

INSTALL MOWER AND DRIVE BELT (See Figs. 5 and 7)

Be sure tractor is on level surface and mower suspension arms are raised with attachment lift control. Engage parking brake.

- Cut and remove ties securing anti-sway bar and belts. Swing anti-sway bar to left side of mower deck.
- Slide mower under tractor with discharge guard to right side of tractor.

IMPORTANT: CHECK BELT FOR PROPER ROUTING IN ALL MOWER PULLEY GROOVES. INSTALL BELT INTO ELECTRIC CLUTCH PULLEY GROOVE.

- Install one front link in top hole of the L.H. front mower bracket and L.H. front suspension bracket. Retain with two single loop retainer springs as shown.
- Install second front link in R.H. front suspension bracket only and retain with single loop retainer spring as shown.
- Slide right side of mower back and install link in top hole of R.H. front mower bracket. Retain with single loop retainer spring as shown.
- Turn height adjustment knob counterclockwise until it stops.
- Lower mower linkage with attachment lift control.

- Place the suspension arms on inward pointing deck pins. If necessary, rock and raise front of mower to align deck pins with the holes in suspension arms. Retain with double loop retainer springs with loops down as shown.
- Connect anti-sway bar to chassis bracket under left footrest and retain with double loop retainer spring.
- Turn height adjustment knob clockwise to remove slack from mower suspension.
- Raise deck to highest position.
- Adjust gauge wheels before operating mower as shown in the Operation section of this manual.

CHECK MOWER LEVELNESS

For best cutting results, mower should be properly leveled. See "TO LEVEL MOWER HOUSING" in the Service and Adjustments section of this manual.

CHECK FOR PROPER POSITION OF ALL BELTS

See the figures that are shown for replacing motion, mower drive, and mower blade drive belts in the Service and Adjustments section of this manual. Verify that the belts are routed correctly.

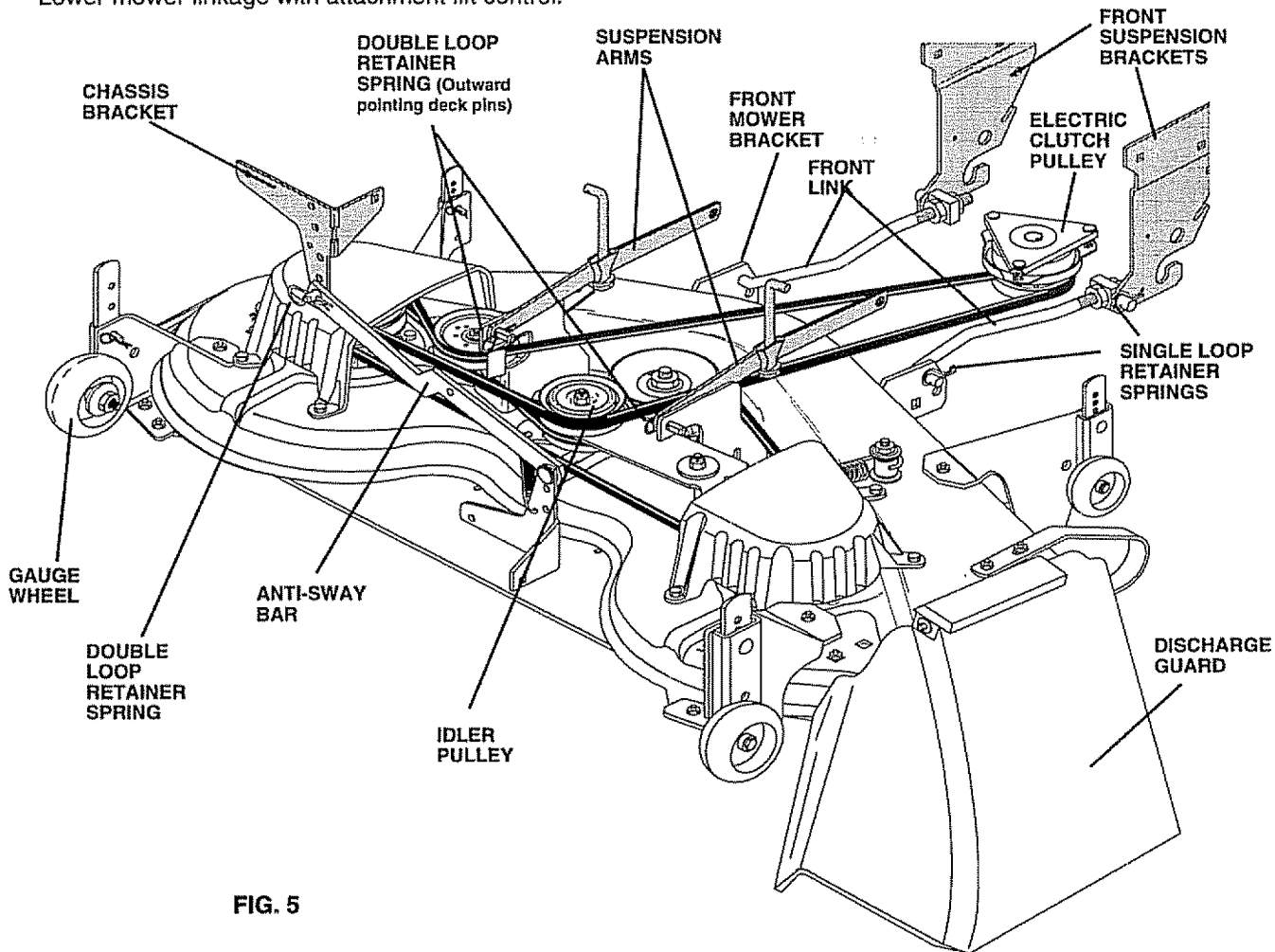

FIG. 5

ASSEMBLY

✓ CHECKLIST

BEFORE YOU OPERATE AND ENJOY YOUR NEW TRACTOR, WE WISH TO ASSURE THAT YOU RECEIVE THE BEST PERFORMANCE AND SATISFACTION FROM THIS QUALITY PRODUCT.

PLEASE REVIEW THE FOLLOWING CHECKLIST:

- ✓ All assembly instructions have been completed.
- ✓ No remaining loose parts in carton.
- ✓ Battery is properly prepared and charged. (Minimum 1 hour at 6 amps).
- ✓ Seat is adjusted comfortably and tightened securely.
- ✓ All tires are properly inflated. (For shipping purposes, the tires were overinflated at the factory).
- ✓ Be sure mower deck is properly leveled side-to-side/ front-to-rear for best cutting results. (Tires must be properly inflated for leveling).
- ✓ Check mower and drive belts. Be sure they are routed properly around pulleys and inside all belt keepers.
- ✓ Check wiring. See that all connections are still secure and wires are properly clamped.
- ✓ Before driving tractor, be sure freewheel control is in drive position.

WHILE LEARNING HOW TO USE YOUR TRACTOR, PAY EXTRA ATTENTION TO THE FOLLOWING IMPORTANT ITEMS:

- ✓ Engine oil is at proper level.
- ✓ Fuel tank is filled with fresh, clean, regular unleaded gasoline.
- ✓ Become familiar with all controls - their location and function. Operate them before you start the engine.
- ✓ Be sure brake system is in safe operating condition.
- ✓ It is important to purge the transmission before operating your tractor for the first time. Follow proper starting and transmission purging instructions (See "TO START ENGINE" and "PURGE TRANSMISSION" in the Operation section of this manual).

OPERATION

These symbols may appear on your tractor or in literature supplied with the product. Learn and understand their meaning.

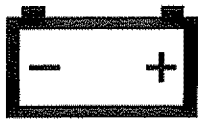

BATTERY



CAUTION OR WARNING



REVERSE



FORWARD



FAST



SLOW



ENGINE ON



ENGINE OFF



OIL PRESSURE



CLUTCH

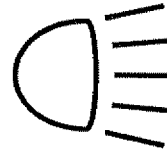

LIGHTS ON



LIGHTS OFF



FUEL



CHOKE

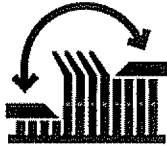

MOWER HEIGHT

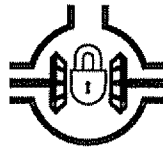

DIFFERENTIAL LOCK



PARKING BRAKE LOCKED



UNLOCKED



MOWER LIFT

R

REVERSE

N

NEUTRAL

H

HIGH

L

LOW

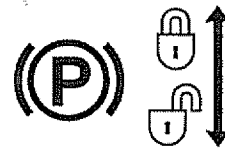

PARKING BRAKE



ATTACHMENT CLUTCH ENGAGED



ATTACHMENT CLUTCH DISENGAGED

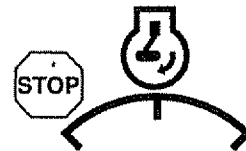

IGNITION

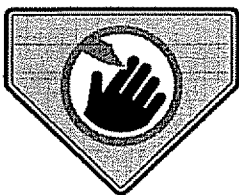

DANGER, KEEP HANDS AND FEET AWAY

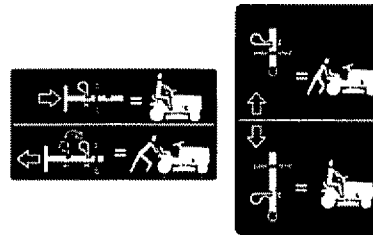

HYDROSTATIC FREE WHEEL
(Hydro Models only)

OPERATION

KNOW YOUR TRACTOR

READ THIS OWNER'S MANUAL AND SAFETY RULES BEFORE OPERATING YOUR TRACTOR.

Compare the illustrations with your tractor to familiarize yourself with the location of various controls and adjustments. Save this manual for future reference.

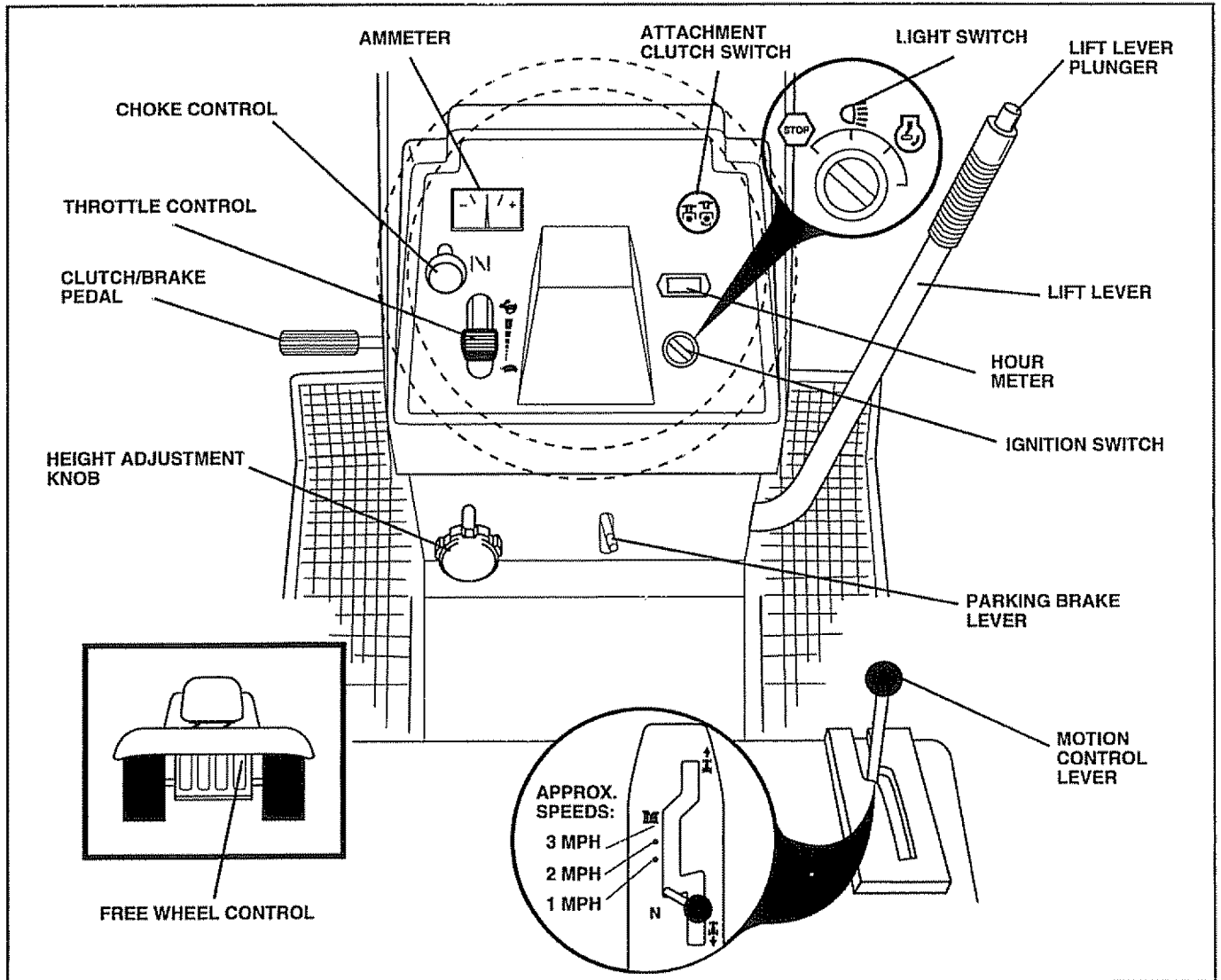

FIG. 6

Our tractors conform to the safety standards of the American National Standards Institute.

ATTACHMENT CLUTCH SWITCH - Used to engage mower blades or other attachments mounted to your tractor.

LIFT LEVER - Used to raise and lower mower deck or other attachments mounted to your tractor.

CLUTCH/BRAKE PEDAL - Used for declutching and braking the tractor and starting the engine.

MOTION CONTROL - Selects the speed and direction of tractor.

CHOKE CONTROL - Used when starting a cold engine.

LIGHT SWITCH - Turns the headlights on and off.

THROTTLE CONTROL - Used to control engine speed.

FREEWHEEL CONTROL - Disengages transmission for pushing or slowly towing the tractor with the engine off.

IGNITION SWITCH - Used to start and stop the engine.

AMMETER - Indicates battery charging (+) or discharging (-).

PARKING BRAKE LEVER - Locks clutch/brake pedal into the brake position.

HEIGHT ADJUSTMENT KNOB - Used to adjust the mower height.

HOURMETER - Indicates hours of operation.

OPERATION



The operation of any tractor can result in foreign objects thrown into the eyes, which can result in severe eye damage. Always wear safety glasses or eye shields while operating your tractor or performing any adjustments or repairs. We recommend a wide vision safety mask over the spectacles or standard safety glasses.

HOW TO USE YOUR TRACTOR

TO SET PARKING BRAKE (See Fig. 7)

Your tractor is equipped with an operator presence sensing switch. When engine is running, any attempt by the operator to leave the seat without first setting the parking brake will shut off the engine.

- Depress clutch/brake pedal into full "BRAKE" position and hold.
- Place parking brake lever in "ENGAGED" position and release pressure from clutch/brake pedal. Pedal should remain in "BRAKE" position. Make sure parking brake will hold tractor secure.

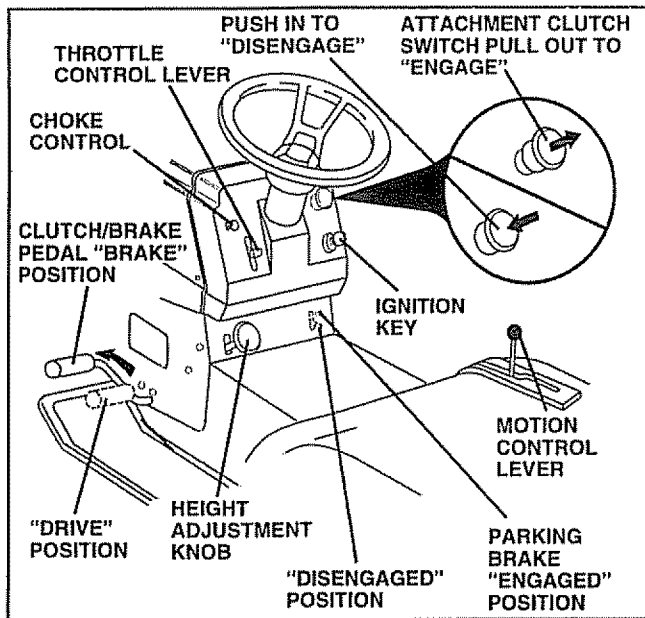

FIG. 7

STOPPING (See Fig. 7)

MOWER BLADES -

- Move attachment clutch switch to "DISENGAGED" position.

GROUND DRIVE -

- Depress clutch/brake pedal into full "BRAKE" position.
- Move motion control lever to neutral (N) position.

IMPORTANT: THE MOTION CONTROL LEVER DOES NOT RETURN TO NEUTRAL (N) POSITION WHEN THE CLUTCH/BRAKE PEDAL IS DEPRESSED.

ENGINE -

- Move throttle control to slow position.

NOTE: Failure to move throttle control to slow position and allowing engine to idle before stopping may cause engine to "backfire".

- Turn ignition key to "OFF" position and remove key. Always remove key when leaving tractor to prevent unauthorized use.
- Never use choke to stop engine.

NOTE: Under certain conditions when unit is standing idle with the engine running, hot engine exhaust gases may cause "browning" of grass. To eliminate this possibility, always stop engine when stopping tractor on grass areas.



CAUTION: Always stop tractor completely, as described above, before leaving the operator's position; to empty grass catcher, etc.

TO USE CHOKE CONTROL (See Fig. 7)

Use choke control whenever you are starting a cold engine. Do not use to start a warm engine.

- To engage choke control, pull knob out. Slowly push knob in to disengage.

TO USE THROTTLE CONTROL (See Fig. 7)

Always operate engine at full throttle.

- Operating engine at less than full throttle reduces the battery charging rate.
- Full throttle offers the best mower performance.

TO MOVE FORWARD AND BACKWARD (See Fig. 7)

The direction and speed of movement is controlled by the motion control lever.

- Start tractor with motion control lever in neutral (N) position.
- Release parking brake and clutch/brake pedal.
- Slowly move motion control lever to desired position.

TO ADJUST MOWER CUTTING HEIGHT (See Fig. 7)

The cutting height is controlled by turning the height adjustment knob in desired direction.

- Turn knob clockwise (↻) to raise cutting height.
- Turn knob counterclockwise (↺) to lower cutting height.

The cutting height range is approximately 1-1/4" to 4-1/2". The heights are measured from the ground to the blade tip with the engine not running. These heights are approximate and may vary depending upon soil conditions, height of grass and types of grass being mowed.

- The average lawn should be cut to approximately 2-1/2 inches during the cool season and to over 3 inches during hot months. For healthier and better looking lawns, mow often and after moderate growth.
- For best cutting performance, grass over 6 inches in height should be mowed twice. Make the first cut relatively high; the second to desired height.

OPERATION

TO ADJUST GAUGE WHEELS (See Fig. 8A)

Gauge wheels are properly adjusted when they are slightly off the ground when mower is at the desired cutting height in operating position. Gauge wheels then keep the deck in proper position to help prevent scalping in most terrain conditions.

- Be sure tractor is on a flat level surface.
- Lower mower and adjust mower to desired cutting height.
- Remove retainer spring and clevis pin which secure each gauge wheel bar.
- Lower gauge wheels to ground. Raise gauge wheels slightly to align holes in bracket and gauge wheel bar and insert clevis pin. Gauge wheels should be slightly off the ground.
- Replace retainer spring into clevis pin.

IMPORTANT: BE SURE TO READJUST GAUGE WHEELS IF YOU CHANGE THE CUTTING HEIGHT OF THE MOWER DECK.

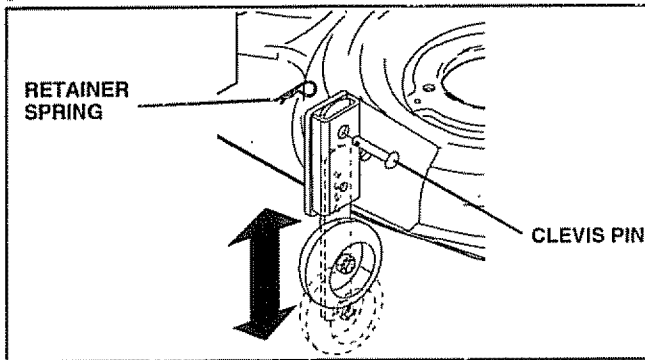

FIG. 8A

TO OPERATE MOWER (See Figs. 6 and 7)

Your tractor is equipped with an operator presence sensing switch. Any attempt by the operator to leave the seat with the engine running and the attachment clutch engaged will shut off the engine.

- Select desired height of cut.
- Lower mower with attachment lift control.
- Start mower blades by engaging attachment clutch control.
- TO STOP MOWER BLADES - disengage attachment clutch control.



CAUTION: Do not operate the mower without either the entire grass catcher, on mowers so equipped, or the discharge guard in place.

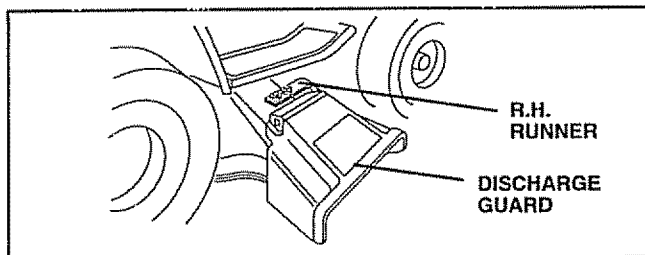

FIG. 8B

TO OPERATE ON HILLS



CAUTION: Do not drive up or down hills with slopes greater than 15° and do not drive across any slope.

- Choose the slowest speed before starting up or down hills.
 - Avoid stopping or changing speed on hills.
 - If slowing is necessary, move throttle control lever to slower position.
 - If stopping is absolutely necessary, push clutch/brake pedal quickly to brake position and engage parking brake.
 - Move motion control lever to neutral (N) position.
- IMPORTANT: THE MOTION CONTROL LEVER DOES NOT RETURN TO NEUTRAL (N) POSITION WHEN THE CLUTCH/BRAKE PEDAL IS DEPRESSED.**
- To restart movement, slowly release parking brake and clutch/brake pedal.
 - Slowly move motion control lever to slowest setting.
 - Make all turns slowly.

TO TRANSPORT (See Figs. 6 and 9)

When pushing or towing your tractor, be sure to disengage transmission by placing freewheel control in freewheeling position. Free wheel control is located at the rear drawbar of tractor.

- Raise attachment lift to highest position with attachment lift control.
- Remove retainer spring from freewheel control rod.
- Push control rod in to disengage transmission and reinsert retainer spring into control rod hole now on back side of the bracket.
- Do not push or tow tractor at more than two (2) MPH.
- To reengage transmission, reverse above procedure.

NOTE: To protect hood from damage when transporting your tractor on a truck or a trailer, be sure hood is closed and secured to tractor. Use an appropriate means of tying hood to tractor (rope, cord, etc.).

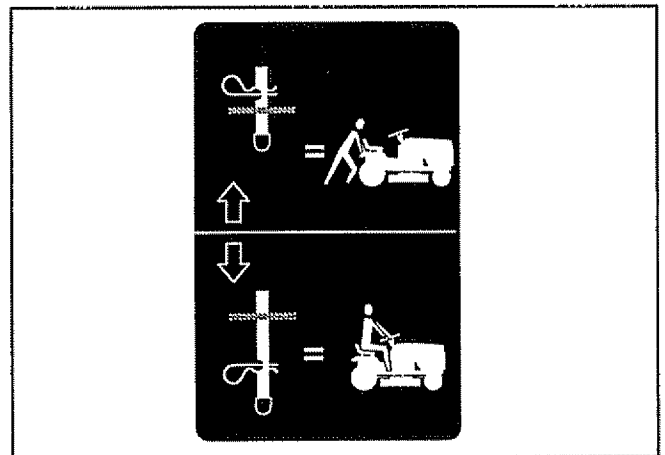

FIG. 9

OPERATION

BEFORE STARTING THE ENGINE

CHECK ENGINE OIL LEVEL (See Fig. 10)

- The engine in your tractor has been shipped, from the factory, already filled with summer weight oil.
- Check engine oil with tractor on level ground.
- Unthread and remove oil fill cap/dipstick; wipe oil off. Reinsert the dipstick into the tube and rest oil fill cap on the tube. Do not thread the cap onto the tube. Remove and read oil level. If necessary, add oil until "FULL" mark on dipstick is reached. Do not overfill.
- For cold weather operation you should change oil for easier starting (See "OIL VISCOSITY CHART" in the Customer Responsibilities section of this manual).
- To change engine oil, see the Customer Responsibilities section in this manual.

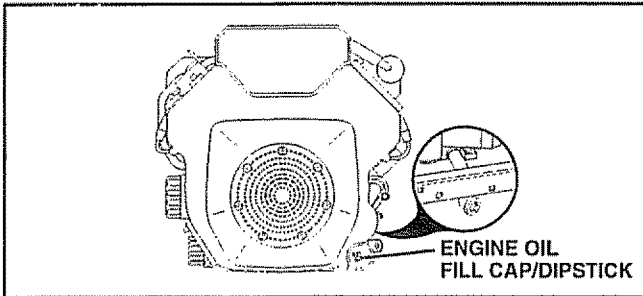

FIG. 10

ADD GASOLINE

- Fill fuel tank. Use fresh, clean, regular unleaded gasoline with a minimum of 87 octane. (Use of leaded gasoline will increase carbon and lead oxide deposits and reduce valve life). Do not mix oil with gasoline. Purchase fuel in quantities that can be used within 30 days to assure fuel freshness.

IMPORTANT: WHEN OPERATING IN TEMPERATURES BELOW 32°F(0°C), USE FRESH, CLEAN WINTER GRADE GASOLINE TO HELP INSURE GOOD COLD WEATHER STARTING.

WARNING: Experience indicates that alcohol blended fuels (called gasohol or using ethanol or methanol) can attract moisture which leads to separation and formation of acids during storage. Acidic gas can damage the fuel system of an engine while in storage. To avoid engine problems, the fuel system should be emptied before storage of 30 days or longer. Drain the gas tank, start the engine and let it run until the fuel lines and carburetor are empty. Use fresh fuel next season. See Storage Instructions for additional information. Never use engine or carburetor cleaner products in the fuel tank or permanent damage may occur.



CAUTION: Fill to bottom of gas tank filler neck. Do not overfill. Wipe off any spilled oil or fuel. Do not store, spill or use gasoline near an open flame.

TO START ENGINE (See Fig. 6)

When starting the engine for the first time or if the engine has run out of fuel, it will take extra cranking time to move fuel from the tank to the engine.

- Be sure freewheel control is in the transmission engaged position.
- Sit on seat in operating position, depress clutch/brake pedal and set parking brake.
- Place motion control lever in neutral (N) position.
- Move attachment clutch to "DISENGAGED" position.
- Move throttle control to fast position
- Pull choke control out for a cold engine start attempt. For a warm engine start attempt the choke control may not be needed.

Note: Before starting, read the warm and cold starting procedures below.

- Insert key into ignition and turn key clockwise to "START" position and release key as soon as engine starts. Do not run starter continuously for more than fifteen seconds per minute. If the engine does not start after several attempts, push choke control in, wait a few minutes and try again. If engine still does not start, pull the choke control out and retry.

WARM WEATHER STARTING (50° F and above)

- When engine starts, slowly push choke control in until the engine begins to run smoothly. If the engine starts to run roughly, pull the choke control out slightly for a few seconds and then continue to push the control in slowly.
- The attachments and ground drive can now be used. If the engine does not accept the load, restart the engine and allow it to warm up for one minute using the choke as described above.

COLD WEATHER STARTING (50° F and below)

- When engine starts, slowly push choke control in until the engine begins to run smoothly. Continue to push the choke control in small steps allowing the engine to accept small changes in speed and load, until the choke control is fully in. If the engine starts to run roughly, pull the choke control out slightly for a few seconds and then continue to push the control in slowly. This may require an engine warm-up period from several seconds to several minutes, depending on the temperature.

HYDROSTATIC TRANSMISSION WARM UP

- Before driving the unit in cold weather, the transmission should be warmed up as follows:
 - Be sure the tractor is on level ground.
 - Place the motion control lever in neutral. Release the parking brake and let the clutch/brake slowly return to operating position.
 - Allow one minute for transmission to warm up. This can be done during the engine warm up period.
- The attachments can be used during the engine warm-up period after the transmission has been warmed up and may require the choke control be pulled out slightly.

NOTE: If at a high altitude (above 3000 feet) or in cold temperatures (below 32 F) the carburetor fuel mixture may need to be adjusted for best engine performance. See "TO ADJUST CARBURETOR" in the Service and Adjustments section of this manual.

OPERATION

PURGE TRANSMISSION



CAUTION: Never engage or disengage freewheel lever while the engine is running.

To ensure proper operation and performance, it is recommended that the transmission be purged before operating tractor for the first time. This procedure will remove any trapped air inside the transmission which may have developed during shipping of your tractor.

IMPORTANT: SHOULD YOUR TRANSMISSION REQUIRE REMOVAL FOR SERVICE OR REPLACEMENT, IT SHOULD BE PURGED AFTER REINSTALLATION BEFORE OPERATING THE TRACTOR.

- Place tractor safely on level surface with engine off and parking brake set.
- Disengage transmission by placing freewheel control in freewheeling position (See "TO TRANSPORT" in this section of manual).
- Sitting in the tractor seat, start engine. After the engine is running, move throttle control to slow position. With motion control lever in neutral (N) position, slowly disengage clutch/brake pedal.
- Move motion control lever to full forward position and hold for five (5) seconds. Move lever to full reverse position and hold for five (5) seconds. Repeat this procedure three (3) times.

NOTE: During this procedure there will be no movement of drive wheels. The air is being removed from hydraulic drive system.

- Move motion control lever to neutral (N) position. Shut-off engine and set parking brake.
- Engage transmission by placing freewheel control in driving position (See "TO TRANSPORT" in this section of manual).
- Sitting in the tractor seat, start engine. After the engine is running, move throttle control to half (1/2) speed. With motion control lever in neutral (N) position, slowly disengage clutch/brake pedal.
- Slowly move motion control lever forward, after the tractor moves approximately five (5) feet, slowly move motion control lever to reverse position. After the tractor moves approximately five (5) feet return the motion control lever to the neutral (N) position. Repeat this procedure with the motion control lever three (3) times.
- Your tractor is now purged and now ready for normal operation.

MOWING TIPS

- Tire chains cannot be used when the mower housing is attached to tractor.
- Mower should be properly leveled for best mowing performance. See "TO LEVEL MOWER HOUSING" in the Service and Adjustments section of this manual.
- Use the runner on the right hand side of mower as a guide. The blade cuts approximately an inch outside the runner (See Fig. 8).
- The left hand side of mower should be used for trimming.
- Drive so that clippings are discharged onto the area that has been cut. Have the cut area to the right of the tractor. This will result in a more even distribution of clippings and more uniform cutting.
- When mowing large areas, start by turning to the right so that clippings will discharge away from shrubs, fences, driveways, etc. After one or two rounds, mow in the opposite direction making left hand turns until finished (See Fig. 11).
- If grass is extremely tall, it should be mowed twice to reduce load and possible fire hazard from dried clippings. Make first cut relatively high; the second to the desired height.
- Do not mow grass when it is wet. Wet grass will plug mower and leave undesirable clumps. Allow grass to dry before mowing.
- Always operate engine at full throttle when mowing to assure better mowing performance and proper discharge of material. Regulate ground speed by selecting a low enough gear to give the mower cutting performance as well as the quality of cut desired.
- When operating attachments, select a ground speed that will suit the terrain and give best performance of the attachment being used.

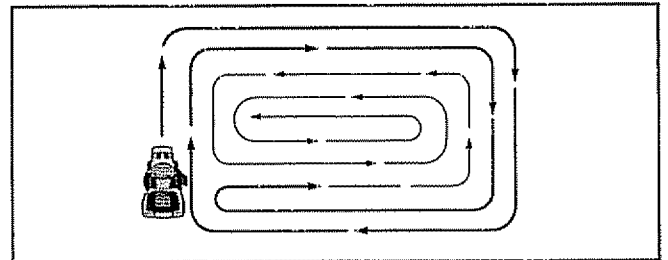

FIG. 11

CUSTOMER RESPONSIBILITIES

MAINTENANCE SCHEDULE FILL IN DATES AS YOU COMPLETE REGULAR SERVICE		BEFORE EACH USE							SERVICE DATES				
		EVERY 8 HOURS	EVERY 25 HOURS	EVERY 50 HOURS	EVERY 100 HOURS	EVERY SEASON	BEFORE STORAGE						
TRACTOR	Check Brake Operation	✓	✓										
	Check Tire Pressure	✓	✓										
	Check for Loose Fasteners	✓				✓ ₇		✓					
	Sharpen/Replace Mower Blades			✓ ₄									
	Lubrication Chart			✓				✓					
	Check Battery Level/Recharge			✓ ₆									
	Clean Battery and Terminals			✓				✓					
	Check Transaxle Cooling			✓									
	Adjust Blade Belt(s) Tension					✓ ₅							
	Adjust Motion Drive Belt(s) Tension					✓ ₅							
ENGINE	Check Engine Oil Level	✓	✓										
	Change Engine Oil			✓ _{1,2,3}				✓					
	Clean Air Filter			✓ ₂									
	Clean Air Screen			✓ ₂									
	Inspect Muffler/Spark Arrester				✓								
	Replace Oil Filter (If equipped)					✓ _{1,2}							
	Clean Engine Cooling Fins					✓ ₂							
	Replace Spark Plug					✓		✓					
	Replace Air Filter Paper Cartridge					✓ ₂							
Replace Fuel Filter							✓						

- 1 - Change more often when operating under a heavy load or in high ambient temperatures
- 2 - Service more often when operating in dirty or dusty conditions.
- 3 - If equipped with oil filter, change oil every 50 hours.
- 4 - Replace blades more often when mowing in sandy soil

- 5 - If equipped with adjustable system.
- 6 - Not required if equipped with maintenance-free battery
- 7 - Tighten front axle pivot bolt to 35 ft.-lbs. maximum
Do not overtighten.

GENERAL RECOMMENDATIONS

The warranty on this tractor does not cover items that have been subjected to operator abuse or negligence. To receive full value from the warranty, operator must maintain tractor as instructed in this manual.

Some adjustments will need to be made periodically to properly maintain your tractor.

All adjustments in the Service and Adjustments section of this manual should be checked at least once each season.

- Once a year you should replace the spark plug, clean or replace air filter, and check blades and belts for wear. A new spark plug and clean air filter assure proper air-fuel mixture and help your engine run better and last longer.

BEFORE EACH USE

- Check engine oil level.
- Check brake operation.
- Check tire pressure.
- Check for loose fasteners.

IMPORTANT: DO NOT OIL OR GREASE THE PIVOT POINTS WHICH HAVE SPECIAL NYLON BEARINGS. VISCOUS LUBRICANTS WILL ATTRACT DUST AND DIRT THAT WILL SHORTEN THE LIFE OF THE SELF-LUBRICATING BEARINGS. IF YOU FEEL THEY MUST BE LUBRICATED, USE ONLY A DRY, POWDERED GRAPHITE TYPE LUBRICANT SPARINGLY.

LUBRICATION CHART

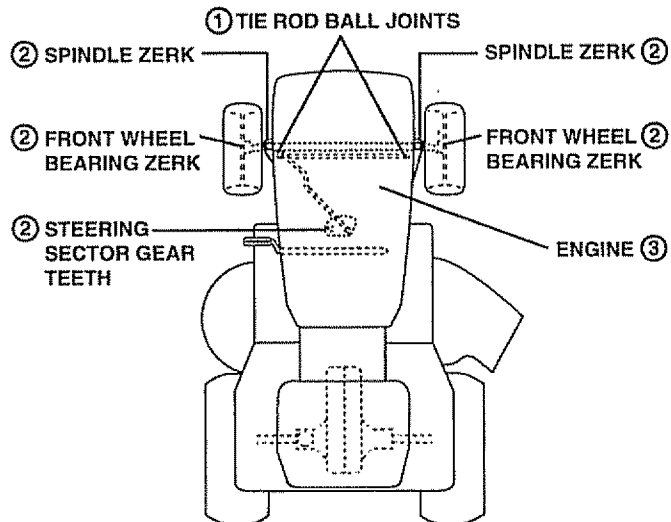

- ① SPRAY SILICONE LUBRICANT (MOVE BOOTS TO LUBRICATE)
- ② GENERAL PURPOSE GREASE
- ③ REFER TO CUSTOMER RESPONSIBILITIES "ENGINE" SECTION

CUSTOMER RESPONSIBILITIES

TRACTOR

Always observe safety rules when performing any maintenance.

BRAKE OPERATION

If tractor requires more than six (6) feet stopping distance at high speed in highest gear, then brake must be adjusted. (See "TO ADJUST BRAKE" in the Service and Adjustments section of this manual).

TIRES

- Maintain proper air pressure in all tires (See "PRODUCT SPECIFICATIONS" on page 3 of this manual).
- Keep tires free of gasoline, oil, or insect control chemicals which can harm rubber.
- Avoid stumps, stones, deep ruts, sharp objects and other hazards that may cause tire damage.

NOTE: To seal tire punctures and prevent flat tires due to slow leaks, tire sealant may be purchased from your local parts dealer. Tire sealant also prevents tire dry rot and corrosion.

BLADE CARE

For best results mower blades must be kept sharp. Replace bent or damaged blades.

BLADE REMOVAL (See Fig. 12)

- Raise mower to highest position to allow access to blades.
- Remove hex bolt, lock washer and flat washer securing blade.
- Install new or resharpened blade with trailing edge up towards deck as shown.
- Reassemble hex bolt, lock washer and flat washer in exact order as shown.
- Tighten bolt securely (30-35 Ft. Lbs. torque).

IMPORTANT: BLADE BOLT IS GRADE 8 HEAT TREATED.

NOTE: We do not recommend sharpening blade - but if you do, be sure the blade is balanced.

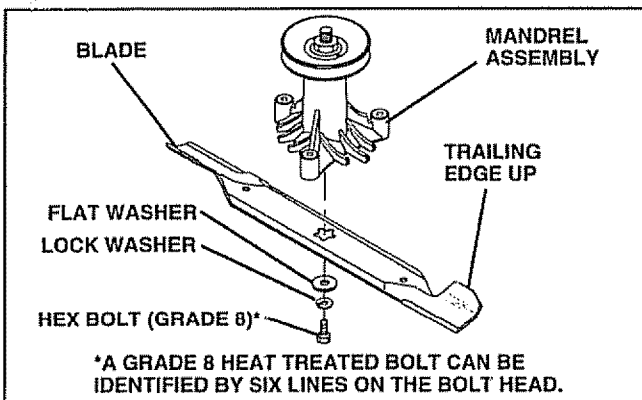

FIG. 12

TO SHARPEN BLADE (See Fig. 13)

Care should be taken to keep the blade balanced. An unbalanced blade will cause excessive vibration and eventual damage to mower and engine.

- The blade can be sharpened with a file or on a grinding wheel. Do not attempt to sharpen while on the mower.
- To check blade balance, you will need a 5/8" diameter steel bolt, pin, or a cone balancer. (When using a cone balancer, follow the instructions supplied with balancer).
- Slide blade on to an unthreaded portion of the steel bolt or pin and hold the bolt or pin parallel with the ground. If blade is balanced, it should remain in a horizontal position. If either end of the blade moves downward, sharpen the heavy end until the blade is balanced.

NOTE: Do not use a nail for balancing blade. The lobes of the center hole may appear to be centered, but are not.

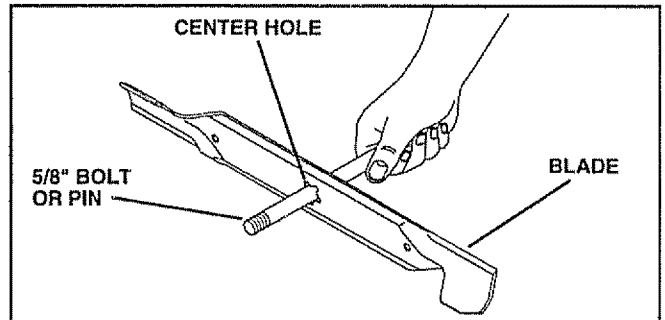

FIG. 13

BATTERY

Your tractor has a battery charging system which is sufficient for normal use. However, periodic charging of the battery with an automotive charger will extend its life.

- Keep battery and terminals clean.
- Keep battery bolts tight.
- Keep small vent holes open.
- Recharge at 6-10 amperes for 1 hour.

TO CLEAN BATTERY AND TERMINALS

Corrosion and dirt on the battery and terminals can cause the battery to "leak" power.

- Remove terminal guard.
- Disconnect BLACK battery cable first then RED battery cable and remove battery from tractor.
- Rinse the battery with plain water and dry.
- Clean terminals and battery cable ends with wire brush until bright.
- Coat terminals with grease or petroleum jelly.
- Reinstall battery (See "CONNECT BATTERY" in the Assembly section of this manual).

CUSTOMER RESPONSIBILITIES

TRANSAXLE COOLING

The fan and cooling fins of transmission should be kept clean to assure proper cooling.

Do not attempt to clean fan or transmission while engine is running or while the transmission is hot. To prevent possible damage to seals, do not use high pressure water or steam to clean transaxle.

- Inspect cooling fan to be sure fan blades are intact and clean.
- Inspect cooling fins for dirt, grass clippings and other materials. To prevent damage to seals, do not use compressed air or high pressure sprayer

TRANSAXLE PUMP FLUID

The transaxle was sealed at the factory and fluid maintenance is not required for the life of the transaxle. Should the transaxle ever leak or require servicing, contact your nearest authorized service center/department.

V-BELTS

Check V-belts for deterioration and wear after 100 hours of operation and replace if necessary. The belts are not adjustable. Replace belts if they begin to slip from wear.

ENGINE

LUBRICATION

Only use high quality detergent oil rated with API service classification SF, SG or SH. Select the oil's SAE viscosity grade according to your expected operating temperature.

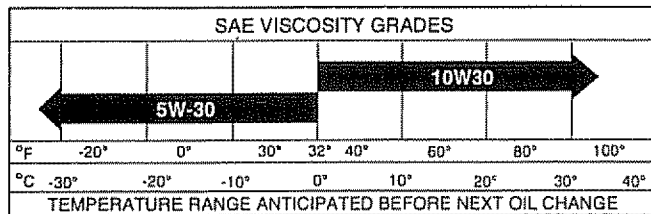

FIG. 14

Change the oil after every 50 hours of operation or at least once a year if the tractor is not used for 50 hours in one year.

Check the crankcase oil level before starting the engine and after each eight (8) hours of operation. Tighten oil fill cap/dipstick securely each time you check the oil level.

TO CHANGE ENGINE OIL (See Figs. 14 and 15)

Determine temperature range expected before oil change. All oil must meet API service classification SF, SG or SH

- Be sure tractor is on level surface.
- Oil will drain more freely when warm.
- Catch oil in a suitable container.
- Remove oil fill cap/dipstick. Be careful not to allow dirt to enter the engine when changing oil.
- Remove drain plug.
- After oil has drained completely, replace oil drain plug and tighten securely.
- Refill engine with oil through oil fill dipstick tube. Pour slowly. Do not overfill. For approximate capacity see "PRODUCT SPECIFICATIONS" on page 3 of this manual.
- Use gauge on oil fill cap/dipstick for checking level. Be sure dipstick is in all the way for accurate reading. Keep oil at "FULL" line on dipstick.

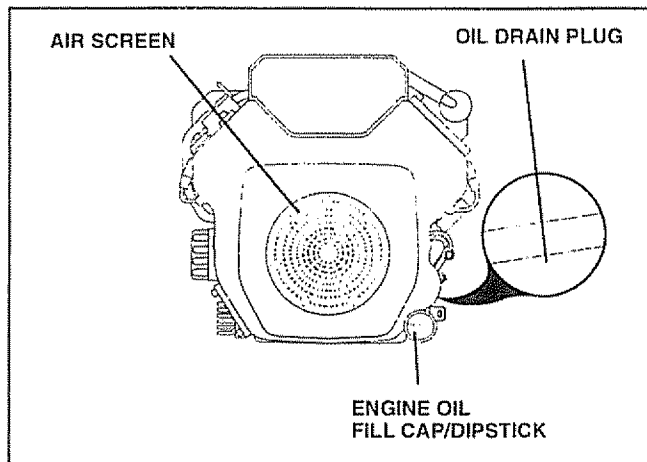

FIG. 15

CLEAN AIR SCREEN (See Fig. 15)

Air screen must be kept free of dirt and chaff to prevent engine damage from overheating. Clean with a wire brush or compressed air to remove dirt and stubborn dried gum fibers.

CUSTOMER RESPONSIBILITIES

CLEAN AIR INTAKE/COOLING AREAS

To insure proper cooling, make sure the grass screen, cooling fins, and other external surfaces of the engine are kept clean at all times.

Every 100 hours of operation (more often under extremely dusty, dirty conditions), remove the blower housing and other cooling shrouds. Clean the cooling fins and external surfaces as necessary. Make sure the cooling shrouds are reinstalled.

NOTE: Operating the engine with a blocked grass screen, dirty or plugged cooling fins, and/or cooling shrouds removed will cause engine damage due to overheating.

AIR FILTER (See Fig. 16)

Your engine will not run properly using a dirty air filter. Clean the foam pre-cleaner after every 25 hours of operation or every season. Service paper cartridge every 100 hours of operation or every season, whichever occurs first.

Service air cleaner more often under dusty conditions.

- Loosen knob and remove cover.

TO SERVICE PRE-CLEANER

- Slide foam pre-cleaner off cartridge.
- Wash it in liquid detergent and water.
- Squeeze it dry in a clean cloth. Allow it to dry.
- Saturate it in engine oil. Wrap it in clean, absorbent cloth and squeeze to remove excess oil.

TO SERVICE CARTRIDGE

- Replace a dirty, bent, or damaged cartridge.

NOTE: Do not wash the paper cartridge or use pressurized air, as this will damage the cartridge.

- Remove nut and cartridge plate.
- Reinstall the pre-cleaner (cleaned and oiled) over the paper cartridge.
- Check rubber seal for damage and proper position around stud. Replace if necessary.
- Reassemble air cleaner, cartridge plate, and nut.
- Reinstall air cleaner cover and secure by tightening knob.

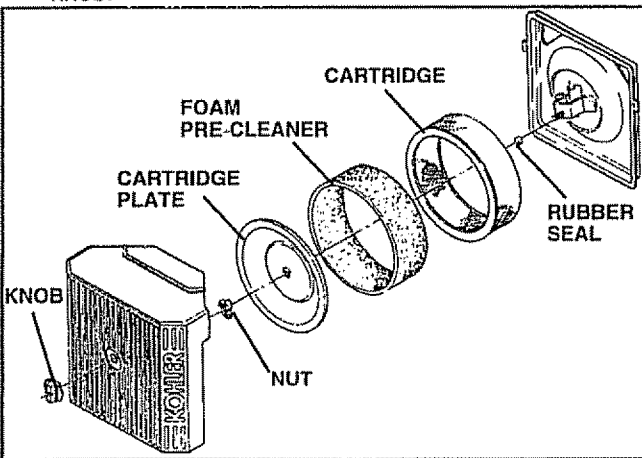

FIG. 16

ENGINE OIL FILTER

Replace the engine oil filter every season or every other oil change if the tractor is used more than 100 hours in one year.

MUFFLER

Inspect and replace corroded muffler and spark arrester (if equipped) as it could create a fire hazard and/or damage.

SPARK PLUGS

Replace spark plugs at the beginning of each mowing season or after every 100 hours of operation, whichever occurs first. Spark plug type and gap setting are shown in "PRODUCT SPECIFICATIONS" on page 3 of this manual.

IN-LINE FUEL FILTER (See Fig. 17)

The fuel filter should be replaced once each season. If fuel filter becomes clogged, obstructing fuel flow to carburetor, replacement is required.

- With engine cool, remove filter and plug fuel line sections.
- Place new fuel filter in position in fuel line with arrow pointing towards carburetor.
- Be sure there are no fuel line leaks and clamps are properly positioned.
- Immediately wipe up any spilled gasoline.

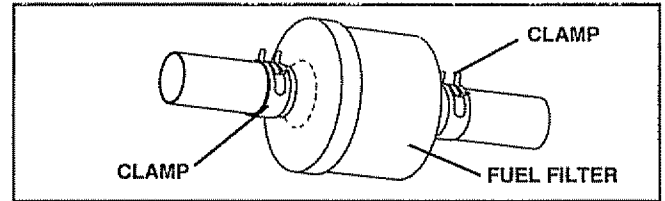

FIG. 17

CLEANING

- Clean engine, battery, seat, finish, etc. of all foreign matter.
- Keep finished surfaces and wheels free of all gasoline, oil, etc.
- Protect painted surfaces with automotive type wax.

We do not recommend using a garden hose to clean your tractor unless the electrical system, muffler, air filter and carburetor are covered to keep water out. Water in engine can result in a shortened engine life.

SERVICE AND ADJUSTMENTS



CAUTION: BEFORE PERFORMING ANY SERVICE OR ADJUSTMENTS:

- Depress clutch/brake pedal fully and set parking brake.
- Place motion control lever in neutral (N) position.
- Place attachment clutch in "DISENGAGED" position.
- Turn ignition key "OFF" and remove key.
- Make sure the blades and all moving parts have completely stopped.
- Disconnect spark plug wire from spark plug and place wire where it cannot come in contact with plug.

TRACTOR

TO REMOVE MOWER (See Fig. 18)

- Place attachment clutch in "DISENGAGED" position.
- Turn height adjustment knob to lowest setting.
- Lower mower to its lowest position.
- Remove retainer spring holding anti-swaybar to chassis bracket and disengage anti-swaybar from bracket.
- Remove retainer springs from suspension arms at deck and disengage arms from deck.
- Raise attachment lift to its highest position.
- Remove two retainer springs from each front link and remove links.
- Slide mower forward and remove belt from electric clutch pulley.
- Slide mower out from under right side of tractor.

IMPORTANT: IF AN ATTACHMENT OTHER THAN THE MOWER DECK IS TO BE MOUNTED ON THE TRACTOR, REMOVE THE FRONT LINKS.

TO INSTALL MOWER

Follow procedure described in "INSTALL MOWER AND DRIVE BELT" in the Assembly section of this manual.

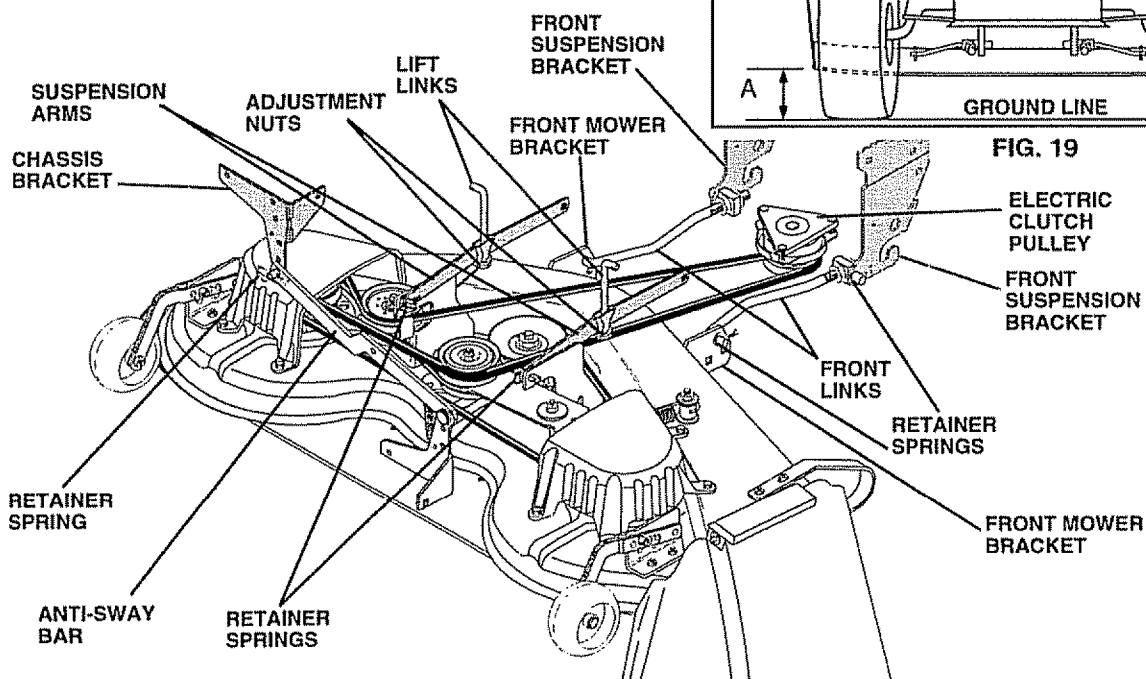

FIG. 18

TO LEVEL MOWER HOUSING

Adjust the mower while tractor is parked on level ground or driveway. Make sure tires are properly inflated (See "PRODUCT SPECIFICATIONS" on page 3 of this manual). If tires are over or underinflated, you will not properly adjust your mower.

SIDE-TO-SIDE ADJUSTMENT (See Figs. 18 and 19)

- Raise mower to its highest position.
- Measure height from bottom of deck curl to ground level at front corners of mower. Distance "A" on both sides of mower should be the same.
- If adjustment is necessary, make adjustment on one side of mower only.
- To raise one side of mower, tighten lift link adjustment nut on that side.
- To lower one side of mower, loosen lift link adjustment nut on that side.

NOTE: Each half turn of adjustment nut will change mower height about 3/16".

- Recheck measurements after adjusting.

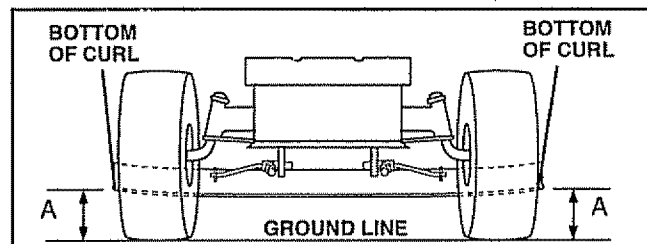

FIG. 19

SERVICE AND ADJUSTMENTS

FRONT-TO-BACK ADJUSTMENT (See Figs. 20 and 21) -

IMPORTANT: DECK MUST BE LEVEL SIDE-TO-SIDE. IF THE FOLLOWING FRONT-TO-BACK ADJUSTMENT IS NECESSARY, BE SURE TO ADJUST BOTH FRONT LINKS EQUALLY SO MOWER WILL STAY LEVEL SIDE-TO-SIDE.

To obtain the best cutting results, the mower housing should be adjusted so the front is approximately 1/8" to 1/2" lower than the rear when the mower is in its highest position.

Check adjustment on right side of tractor. Measure distance "F" directly in front of and behind the mandrel at bottom edge of mower housing as shown.

- Before making any necessary adjustments, check that both front links are equal in length.
- If links are not equal in length, adjust one link to same length as other link.
- To lower front of mower housing, loosen nut "G" on both front links an equal number of turns.
- When distance "F" is 1/8" to 1/2" lower at front than rear, tighten nut "H" against trunnion on both front links.
- To raise front of mower housing, loosen nut "H" from trunnion on both front links. Tighten nut "G" on both front links an equal number of turns.
- When distance "F" is 1/8" to 1/2" lower at front than rear, tighten nut "H" against trunnion on both front links.

NOTE: Each full turn of nut "G" will change dim. "F" by approximately 3/8".

- Recheck side-to-side adjustment.

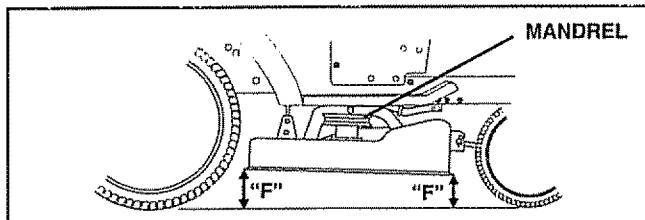

FIG. 20

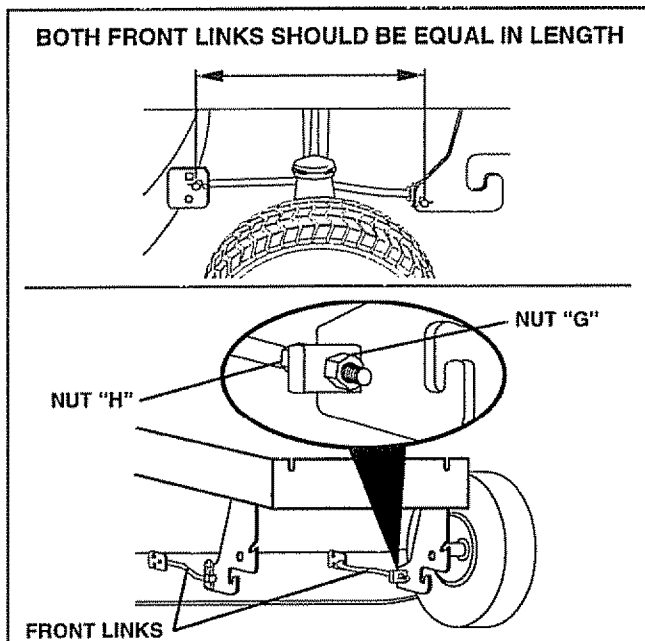

FIG. 21

TO REPLACE MOWER DRIVE BELT

MOWER DRIVE BELT REMOVAL (See Fig. 22) -

- Park tractor on a level surface. Engage parking brake.
- Remove four screws from L.H. mandrel cover and remove cover.
- Roll belt over the top of L.H. mandrel pulley.
- Remove belt from electric clutch pulley.
- Remove belt from idler pulleys.
- Remove any dirt or grass clippings which may have accumulated around mandrels and entire upper deck surface.
- Check primary idler arm and two idlers to see that they rotate freely.
- Be sure spring is securely hooked to primary idler arm and bolt in mower housing.

MOWER DRIVE BELT INSTALLATION (See Fig. 22) -

- Install belt in both idlers. Make sure belt is in both belt keepers at the idlers as shown.
- Install new belt onto electric clutch pulley.
- Roll belt into upper groove of L.H. mandrel pulley.
- Carefully check belt routing making sure belt is in the grooves correctly and inside belt keepers.
- Reassemble L.H. mandrel cover.

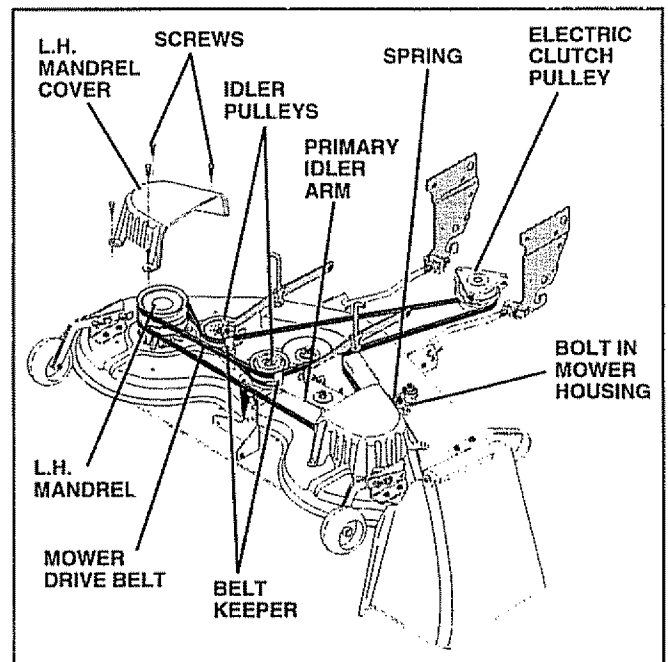

FIG. 22

SERVICE AND ADJUSTMENTS

TO REPLACE MOWER BLADE DRIVE BELT (See Fig. 23)

Park the tractor on level surface. Engage parking brake.

- Remove mower drive belt (See "TO REPLACE MOWER DRIVE BELT" in this section of this manual).
- Remove mower (See "TO REMOVE MOWER" in this section of this manual).
- Remove four screws from R.H. mandrel cover and remove cover. Unhook spring from bolt on mower housing.
- Carefully roll belt off R.H. mandrel pulley.
- Remove belt from center mandrel pulley, idler pulley, and L.H. mandrel pulley.
- Remove any dirt or grass which may have accumulated around mandrels and entire upper deck surface.
- Check secondary idler arm and idler to see that they rotate freely.
- Be sure spring is hooked in secondary idler arm and sway-bar bracket.
- Install new belt in lower groove of L.H. mandrel pulley, idler pulley, and center mandrel pulley as shown.
- Roll belt over R.H. mandrel pulley. Make sure belt is in all grooves properly.
- Reconnect spring to bolt in mower housing and reinstall R.H. mandrel cover.
- Reinstall mower to tractor (See "INSTALL MOWER AND DRIVE BELT" in the Assembly section of this manual).
- Reassemble mower drive belt (See "TO REPLACE MOWER DRIVE BELT" in this section of this manual).

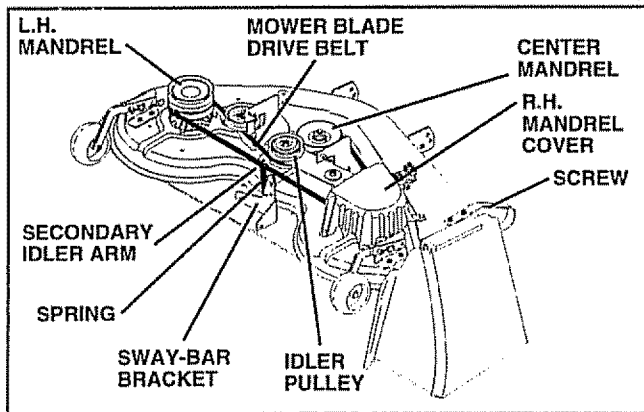

FIG. 23

TO ADJUST ATTACHMENT CLUTCH (See Fig. 24)

The electric clutch should provide years of service. The clutch has a built-in brake that stops the pulley within 5 seconds. Eventually, the internal brake will wear which may cause the mower blades to not engage, or, to not stop as required. Adjustments should be made by your nearest authorized service center/department.

- Make sure attachment clutch and ignition switches are in "OFF" position.
- Adjust the three nylon locknuts until space between clutch plate and rotor measures .012" at all three slot locations cut in side of brake plate.

NOTE: After installing a new electric clutch, run tractor at full throttle and engage and disengage electric clutch 10 cycles to wear in clutch plate.

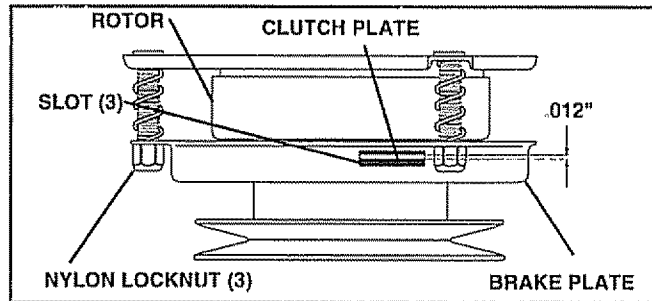

FIG. 24

TO ADJUST BRAKE (See Fig. 25)

Your tractor is equipped with an adjustable brake system which is mounted on the side of the transaxle.

If tractor requires more than six (6) feet stopping distance at high speed in highest gear, then brake must be adjusted.

- Depress clutch/brake pedal and engage parking brake.
- Measure distance between brake operating arm and nut "A" on brake rod.
- If distance is other than 1-1/2", loosen jam nut and turn nut "A" until distance becomes 1-1/2". Retighten jam nut against nut "A".
- Road test tractor for proper stopping distance as stated above. Readjust if necessary. If stopping distance is still greater than six (6) feet in highest gear, further maintenance is necessary. Contact your nearest authorized service center/department.

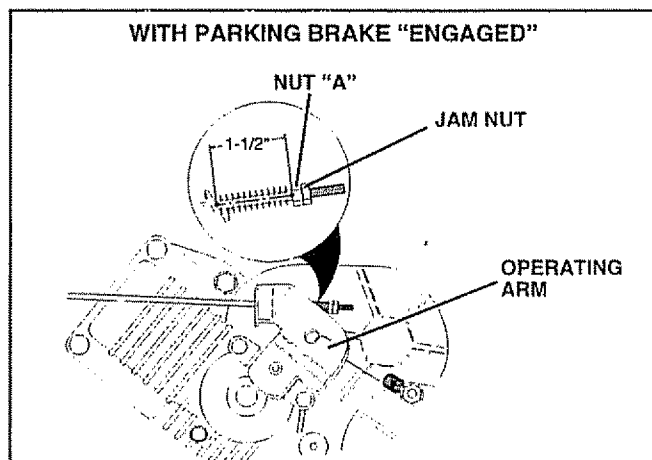

FIG. 25

SERVICE AND ADJUSTMENTS

TO REPLACE MOTION DRIVE BELT (See Fig. 26)

Park the tractor on level surface. Engage parking brake. For ease of service there is a belt installation guide decal on bottom of left footrest.

- Remove mower (See "TO REMOVE MOWER" in this section of this manual.)

BELT REMOVAL -

- Engage parking brake (creates slack in belt).
- Remove belt from clutching and fan idler pulleys.
- Loosen belt keeper above transaxle pulley.
- Remove belt from transaxle pulley.
- Remove belt from engine pulley and front V-idler pulley.
- Pull belt out of all belt keepers and remove from tractor.

BELT INSTALLATION -

- Place V part of belt into grooves on engine pulley and front V-idler, making sure to route belt inside of all belt keepers.
- Route belt on right side, coming from V-idler, towards back of tractor, above midspan belt keeper and to top of transaxle pulley.
- Route belt on left side, coming from engine pulley, towards back of tractor and through loop in midspan belt keeper.
- Place V part of belt into grooves on transaxle and fan idler pulleys, making sure to route belt inside of all belt keepers.
- Retighten belt keeper above transaxle pulley.
- Place belt around clutching idlers as shown, making sure to route belt inside of all belt keepers.
- Check to be sure belt is positioned correctly and is on proper side of all belt keepers.
- Reinstall mower.

IMPORTANT: CHECK BRAKE ADJUSTMENT.

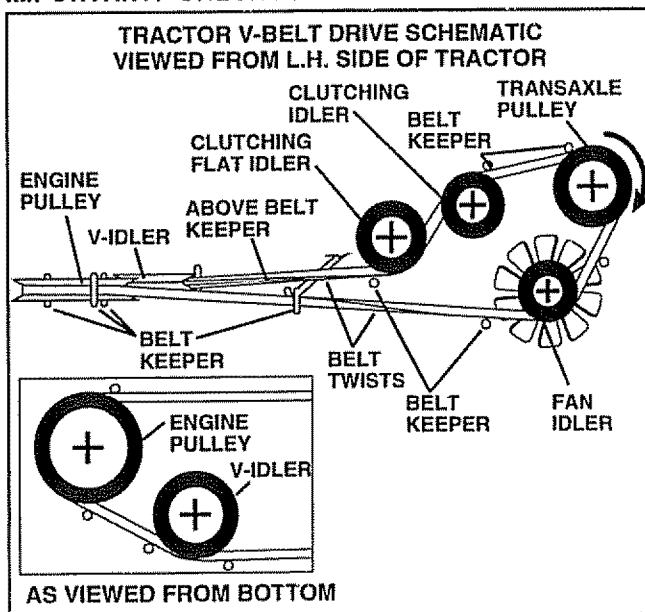

FIG. 26

TO ADJUST MOTION CONTROL LEVER (See Fig. 27)

The motion control lever has been preset at the factory and adjustment should not be necessary.

If for any reason the motion control lever will not hold its position while at a selected speed, it may be adjusted at the friction pack located on the right side of chassis.

- Park tractor on level surface. Stop tractor by turning ignition key to "OFF" position and engage parking brake.
- Place motion control lever in neutral (N) position.
- While holding locknut, loosen jam nut
- Tighten locknut 1/4 turn.
- While holding locknut, tighten jam nut securely.

NOTE: If for any reason the effort to move the motion control lever becomes too excessive, reverse the above adjustment procedure by loosening locknut 1/4 turn.

Road test tractor after adjustment and repeat procedure if necessary.

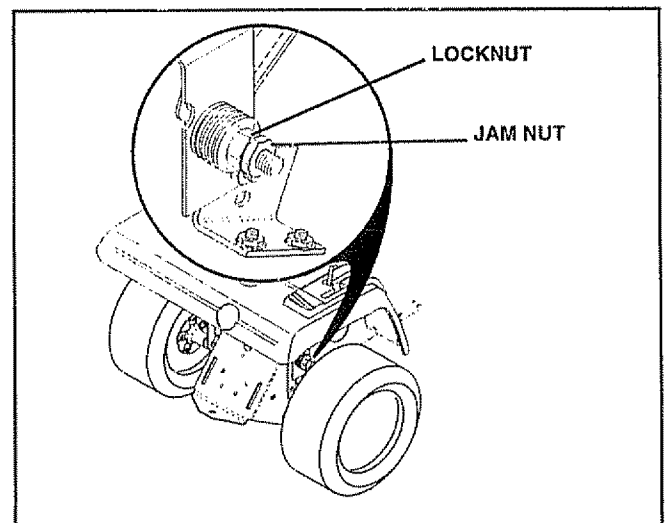

FIG. 27

TRANSMISSION REMOVAL/REPLACEMENT

Should your transmission require removal for service or replacement, it should be purged after reinstallation before operating the tractor. See "PURGE TRANSMISSION" in Operation section of this manual.

TO ADJUST STEERING WHEEL ALIGNMENT

If steering wheel crossbars are not horizontal (left to right) when wheels are positioned straight forward, remove steering wheel and reassemble per instructions in the Assembly section of this manual.

SERVICE AND ADJUSTMENTS

FRONT WHEEL TOE-IN ADJUSTMENT

Front wheel toe-in is required for proper steering operation. Toe-in was set at the factory and adjustment should not be necessary. If parts in the front axle or steering mechanism have been replaced or damaged, check toe-in and adjust if necessary.

TO CHECK TOE-IN (See Fig. 28) -

- Position front wheels straight ahead.
- Measure distance between wheels at front and rear of tires (dimensions "A" and "B").
- Front dimension "A" should be 1/8" to 1/4" less than rear dimension "B".

TO ADJUST TOE-IN (See Figs. 28 and 29) -

- Loosen jam nuts at adjustment sleeves on tie rod.
- Adjust tie rod until dimension "A" is 1/8" to 1/4" less than dimension "B".
- Tighten jam nuts securely.

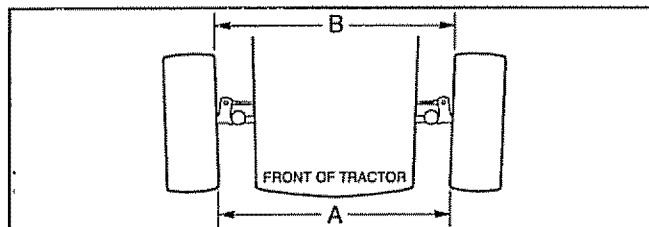

FIG. 28

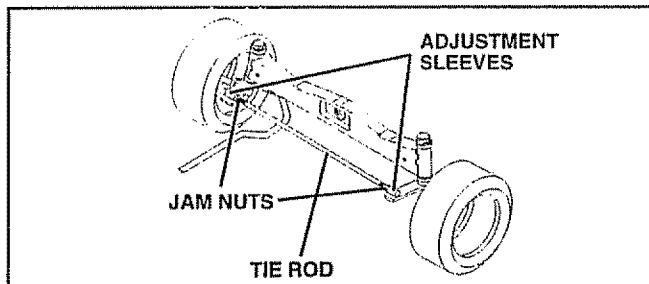

FIG. 29

FRONT WHEEL CAMBER

The front wheel camber is not adjustable on your tractor. If damage has occurred to affect the front wheel camber, contact your nearest authorized service center/department.

TO REMOVE WHEEL FOR REPAIRS

FRONT WHEEL (See Fig. 30) -

- Block up axle securely.
- Remove axle cover, retaining ring and washers to allow wheel removal.
- Repair tire and reassemble.
- Replace washers and snap retaining ring securely in axle groove.
- Replace axle cover.

REAR WHEEL -

- Block rear axle securely.
- Remove five (5) hub bolts to allow wheel removal.
- Repair tire and reassemble. Replace and tighten hub bolts securely.

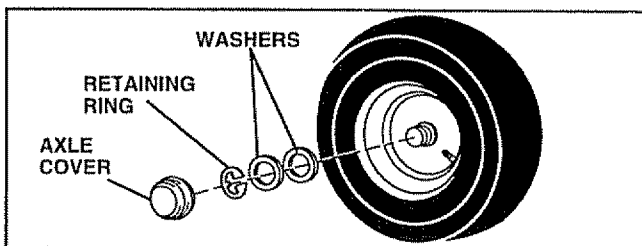

FIG. 30

NOTE: To seal tire punctures and prevent flat tires due to slow leaks, tire sealant may be purchased from your local parts dealer. Tire sealant also prevents tire dry rot and corrosion.

TO START ENGINE WITH A WEAK BATTERY (See Fig. 31)



CAUTION: Lead-acid batteries generate explosive gases. Keep sparks, flame and smoking materials away from batteries. Always wear eye protection when around batteries.

If your battery is too weak to start the engine, it should be recharged. If "jumper cables" are used for emergency starting, follow this procedure:

IMPORTANT: YOUR TRACTOR IS EQUIPPED WITH A 12 VOLT NEGATIVE GROUND SYSTEM. THE OTHER VEHICLE MUST ALSO BE A 12 VOLT NEGATIVE GROUND SYSTEM. DO NOT USE YOUR TRACTOR BATTERY TO START OTHER VEHICLES.

TO ATTACH JUMPER CABLES -

- Connect each end of the RED cable to the POSITIVE (+) terminal of each battery, taking care not to short against chassis.
- Connect one end of the BLACK cable to the NEGATIVE (-) terminal of fully charged battery.
- Connect the other end of the BLACK cable to good CHASSIS GROUND, away from fuel tank and battery.

TO REMOVE CABLES, REVERSE ORDER -

- BLACK cable first from chassis and then from the fully charged battery.
- RED cable last from both batteries.

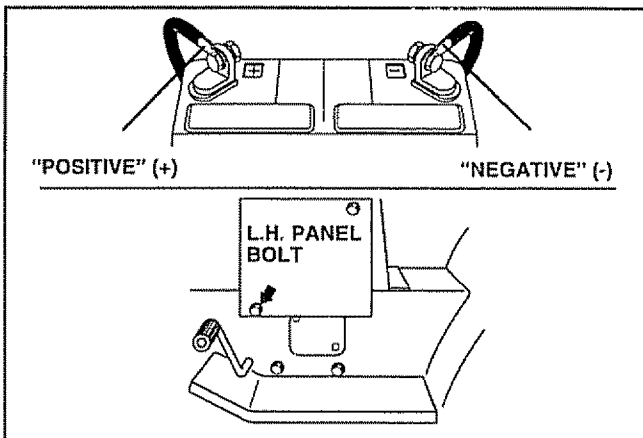

FIG. 31

SERVICE AND ADJUSTMENTS

TO REPLACE HEADLIGHT BULB

- Raise hood.
- Pull bulb holder out of the hole in the backside of the grill.
- Replace bulb in holder and push bulb holder securely back into the hole in the backside of the grill.
- Close hood.

INTERLOCKS AND RELAYS

Loose or damaged wiring may cause your tractor to run poorly, stop running, or prevent it from starting.

- Check wiring. See electrical wiring diagram in the Repair Parts section of this manual.

TO REPLACE FUSE

Replace with 30 amp automotive-type plug-in fuse. The fuse holder is located behind the dash.

TO ADJUST ATTACHMENT LIFT SPRING (See Fig. 32)

- While holding spring bushing with wrench, loosen jam nut.
- Turn adjustment bolt clockwise to extend spring and reduce lift effort for heavier attachments.
- Turn adjustment bolt counterclockwise for lighter attachments.
- Retighten jam nut against spring bushing.

IMPORTANT: DO NOT ADJUST FOR MAXIMUM SPRING TENSION WHEN USING LIGHT ATTACHMENTS SUCH AS A MOWER. ADJUST LIFT LEVER SPRING TO AID IN LIFTING ATTACHMENT. DO NOT OVERPOWER SPRING. WHEN REMOVING ATTACHMENT, ALWAYS ADJUST SPRING TENSION TO ITS LOWEST POSITION.

TO REMOVE HOOD AND GRILL ASSEMBLY (See Fig. 33)

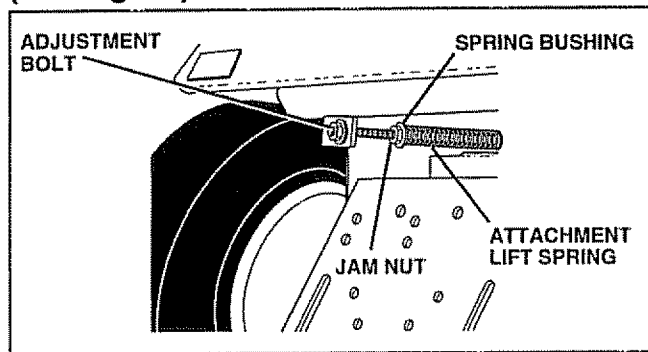

FIG. 32

- Raise hood.
- Unsnap headlight wire connector.
- Stand in front of tractor. Grasp hood at sides, tilt toward engine and lift off of tractor.
- To replace, reverse above procedures.

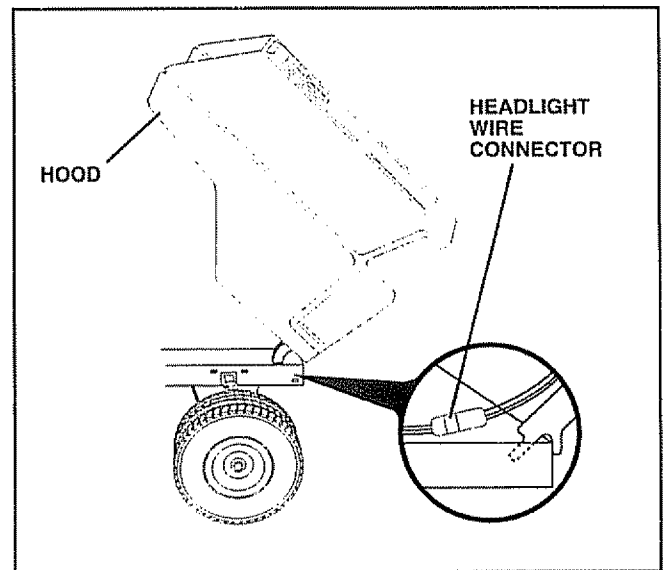

FIG. 33

ENGINE

TO ADJUST THROTTLE CONTROL CABLE (See Fig. 34)

The throttle control has been preset at the factory and adjustment should not be necessary. Check adjustment as described below before loosening cable. If adjustment is necessary, proceed as follows:

- With engine not running, move throttle control lever to fast position.
- Check that speed control lever is against stop screw. If it is not, loosen casing clamp screw and pull throttle cable until lever is against screw. Tighten clamp screw securely.

SERVICE AND ADJUSTMENTS

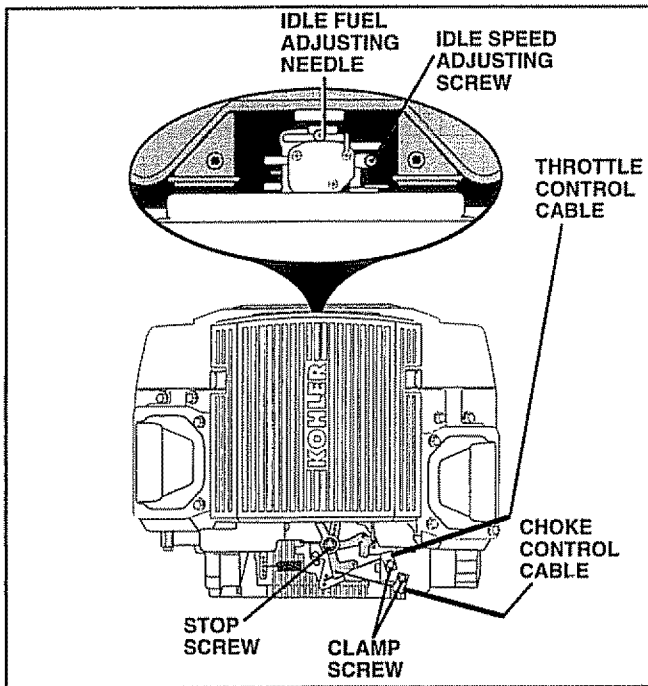

FIG. 34

TO ADJUST CHOKE CONTROL (See Figs. 34 and 35)

The choke control has been preset at the factory and adjustment should not be necessary. Check adjustment as described below before loosening cable. If adjustment is necessary, proceed as follows:

- With engine not running, move choke control (located on dash panel) to full choke position.
- Remove air cleaner cover, filter and cartridge plate to expose carburetor choke (See "AIR FILTER" in the Customer Responsibilities section of this manual).
- Choke should be closed. If it is not, loosen casing clamp screw and move choke cable until choke is completely closed. Tighten casing clamp screw securely.
- Reassemble air cleaner.

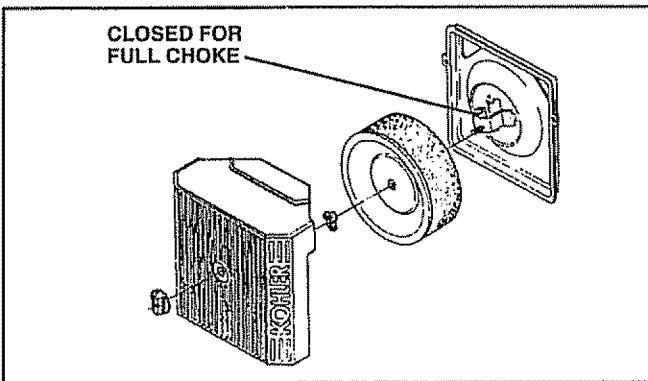

FIG. 35

TO ADJUST CARBURETOR (See Fig. 34)

The carburetor has been present at the factory and adjustment should not be necessary. However, minor adjustment may be required to compensate for differences in fuel, temperature, altitude or load. If the carburetor does need adjustment, proceed as follows:

In general, turning the adjusting needles **in** (clockwise) decreases the supply of fuel to the engine giving a leaner fuel/air mixture. Turning the adjusting needles **out** (counterclockwise) increases the supply of fuel to the engine giving a richer fuel/air mixture.

IMPORTANT: DAMAGE TO THE NEEDLES AND THE SEATS IN CARBURETOR MAY RESULT IF SCREW IS TURNED IN TOO TIGHT.

PRELIMINARY SETTING -

- Be sure you have a clean air filter, and the throttle control cable is adjusted properly (see "TO ADJUST THROTTLE CONTROL CABLE" in the Service and Adjustments section of this manual).
- With engine off turn idle fuel adjusting needle **in** (clockwise) closing it finger tight and then turn **out** (counterclockwise) 1 turn.

FINAL SETTING -

- Start engine and allow to warm for five minutes. Make final adjustments with engine running and shift/motion control lever in neutral (N) position.
- The high idle is set at the factory and cannot be adjusted.
- Idle speed setting - With throttle control lever in slow position, engine should idle at 1200 RPM. If engine idles too slow or fast, turn idle speed adjusting screw in or out until correct idle is attained.
- Idle fuel needle setting - With throttle control lever in slow position, turn idle fuel adjusting needle **in** (clockwise) until engine speed decreases and then turn **out** (counterclockwise) approximately 3/4 turn to obtain the best low speed performance.
- Recheck idle speed. Readjust if necessary.

ACCELERATION TEST -

- Move throttle control lever from slow to fast position. If engine hesitates or dies, turn idle fuel adjusting needle **out** (counterclockwise) 1/8 turn. Repeat test and continue to adjust, if necessary, until engine accelerates smoothly.

High speed stop is factory adjusted. Do not adjust-damage may result.

IMPORTANT: NEVER TAMPER WITH THE ENGINE GOVERNOR, WHICH IS FACTORY SET FOR PROPER ENGINE SPEED. OVERSPEEDING THE ENGINE ABOVE THE FACTORY HIGH SPEED SETTING CAN BE DANGEROUS. IF YOU THINK THE ENGINE-GOVERNED HIGH SPEED NEEDS ADJUSTING, CONTACT YOUR NEAREST AUTHORIZED SERVICE CENTER/DEPARTMENT, WHICH HAS PROPER EQUIPMENT AND EXPERIENCE TO MAKE ANY NECESSARY ADJUSTMENTS.

STORAGE

Immediately prepare your tractor for storage at the end of the season or if the tractor will not be used for 30 days or more.

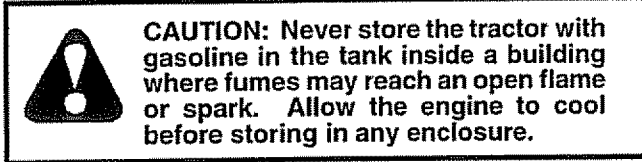

TRACTOR

Remove mower from tractor for winter storage. When mower is to be stored for a period of time, clean it thoroughly, remove all dirt, grease, leaves, etc. Store in a clean, dry area.

- Clean entire tractor (See "CLEANING" in the Customer Responsibilities section of this manual).
- Inspect and replace belts, if necessary (See belt replacement instructions in the Service and Adjustments section of this manual).
- Lubricate as shown in the Customer Responsibilities section of this manual.
- Be sure that all nuts, bolts and screws are securely fastened. Inspect moving parts for damage, breakage and wear. Replace if necessary.
- Touch up all rusted or chipped paint surfaces; sand lightly before painting.

BATTERY

- Fully charge the battery for storage.
- After a period of time in storage, battery may require recharging.
- To help prevent corrosion and power leakage during long periods of storage, battery cables should be disconnected and battery cleaned thoroughly (see "TO CLEAN BATTERY AND TERMINALS" in the Customer Responsibilities section of this manual).
- After cleaning, leave cables disconnected and place cables where they cannot come in contact with battery terminals.
- Be sure battery drain tube is securely attached.
- If battery is removed from tractor for storage, do not store battery directly on concrete or damp surfaces.

ENGINE

FUEL SYSTEM

IMPORTANT: IT IS IMPORTANT TO PREVENT GUM DEPOSITS FROM FORMING IN ESSENTIAL FUEL SYSTEM PARTS SUCH AS CARBURETOR, FUEL FILTER, FUEL HOSE, OR TANK DURING STORAGE. ALSO, EXPERIENCE INDICATES THAT ALCOHOL BLENDED FUELS (CALLED GASOHOL OR USING ETHANOL OR METHANOL) CAN ATTRACT MOISTURE WHICH LEADS TO SEPARATION AND FORMATION OF ACIDS DURING STORAGE. ACIDIC GAS CAN DAMAGE THE FUEL SYSTEM OF AN ENGINE WHILE IN STORAGE.

- Drain the fuel tank.
- Start the engine and let it run until the fuel lines and carburetor are empty.
- Never use engine or carburetor cleaner products in the fuel tank or permanent damage may occur.
- Use fresh fuel next season.

NOTE: Fuel stabilizer is an acceptable alternative in minimizing the formation of fuel gum deposits during storage. Add stabilizer to gasoline in fuel tank or storage container. Always follow the mix ratio found on stabilizer container. Run engine at least 10 minutes after adding stabilizer to allow the stabilizer to reach the carburetor. Do not drain the gas tank and carburetor if using fuel stabilizer.

ENGINE OIL

Drain oil (with engine warm) and replace with clean engine oil. (See "ENGINE" in the Customer Responsibilities section of this manual).

CYLINDERS

- Remove spark plug(s).
- Pour one ounce of oil through spark plug hole(s) into cylinder(s).
- Turn ignition key to "START" position for a few seconds to distribute oil.
- Replace with new spark plug(s).

OTHER

- Do not store gasoline from one season to another.
- Replace your gasoline can if your can starts to rust. Rust and/or dirt in your gasoline will cause problems.
- If possible, store your tractor indoors and cover it to give protection from dust and dirt.
- Cover your tractor with a suitable protective cover that does not retain moisture. Do not use plastic. Plastic cannot breathe which allows condensation to form and will cause your tractor to rust.

IMPORTANT: NEVER COVER TRACTOR WHILE ENGINE AND EXHAUST AREAS ARE STILL WARM.

TROUBLESHOOTING POINTS

PROBLEM	CAUSE	CORRECTION
Will not start	<ol style="list-style-type: none"> 1. Out of fuel. 2. Engine not "CHOKED" properly. 3. Engine flooded. 4. Bad spark plug. 5. Dirty air filter. 6. Dirty fuel filter. 7. Water in fuel. 8. Loose or damaged wiring 9. Carburetor out of adjustment 10. Engine valves out of adjustment. 	<ol style="list-style-type: none"> 1. Fill fuel tank. 2. See "TO START ENGINE" in Operation section. 3. Wait several minutes before attempting to start. 4. Replace spark plug. 5. Clean/replace air filter. 6. Replace fuel filter. 7. Drain fuel tank and carburetor, refill tank with fresh gasoline and replace fuel filter. 8. Check all wiring. 9. See "To Adjust Carburetor" in Service Adjustments section. 10. Contact an authorized service center/department.
Hard to start	<ol style="list-style-type: none"> 1. Dirty air filter. 2. Bad spark plug. 3. Weak or dead battery. 4. Dirty fuel filter. 5. Stale or dirty fuel. 6. Loose or damaged wiring. 7. Carburetor out of adjustment. 8. Engine valves out of adjustment 	<ol style="list-style-type: none"> 1. Clean/replace air filter. 2. Replace spark plug. 3. Recharge or replace battery. 4. Replace fuel filter. 5. Drain fuel tank and refill with fresh gasoline. 6. Check all wiring. 7. See "To Adjust Carburetor" in Service Adjustments section. 8. Contact an authorized service center/department.
Engine will not turn over	<ol style="list-style-type: none"> 1. Clutch/brake pedal not depressed. 2. Attachment clutch is engaged 3. Weak or dead battery. 4. Blown fuse 5. Corroded battery terminals 6. Loose or damaged wiring. 7. Faulty ignition switch. 8. Faulty solenoid or starter. 9. Faulty operator presence switch(es). 	<ol style="list-style-type: none"> 1. Depress clutch/brake pedal. 2. Disengage attachment clutch. 3. Recharge or replace battery. 4. Replace fuse. 5. Clean battery terminals 6. Check all wiring. 7. Check/replace ignition switch. 8. Check/replace solenoid or starter. 9. Contact an authorized service center/department.
Engine clicks but will not start	<ol style="list-style-type: none"> 1. Weak or dead battery. 2. Corroded battery terminals. 3. Loose or damaged wiring. 4. Faulty solenoid or starter. 	<ol style="list-style-type: none"> 1. Recharge or replace battery. 2. Clean battery terminals. 3. Check all wiring. 4. Check/replace solenoid or starter.
Loss of power	<ol style="list-style-type: none"> 1. Cutting too much grass/too fast. 2. Throttle in "CHOKE" position. 3. Build-up of grass, leaves and trash under mower. 4. Dirty air filter. 5. Low oil level/dirty oil. 6. Faulty spark plug. 7. Dirty fuel filter. 8. Stale or dirty fuel. 9. Water in fuel. 10. Spark plug wire loose. 11. Dirty engine air screen/fins. 12. Dirty/clogged muffler. 13. Loose or damaged wiring. 14. Carburetor out of adjustment. 15. Engine valves out of adjustment 	<ol style="list-style-type: none"> 1. Set in "Higher Cut" position/reduce speed. 2. Adjust throttle control 3. Clean underside of mower housing 4. Clean/replace air filter. 5. Check oil level/change oil. 6. Clean and regap or change spark plug 7. Replace fuel filter. 8. Drain fuel tank and refill with fresh gasoline. 9. Drain fuel tank and carburetor, refill tank with fresh gasoline and replace fuel filter. 10. Connect and tighten spark plug wire. 11. Clean engine air screen/fins. 12. Clean/replace muffler. 13. Check all wiring. 14. See "To Adjust Carburetor" in Service Adjustments section. 15. Contact an authorized service center/department
Excessive vibration	<ol style="list-style-type: none"> 1. Worn, bent or loose blade 2. Bent blade mandrel 3. Loose/damaged part(s). 	<ol style="list-style-type: none"> 1. Replace blade. Tighten blade bolt. 2. Replace blade mandrel. 3. Tighten loose part(s). Replace damaged parts.

TROUBLESHOOTING POINTS

PROBLEM	CAUSE	CORRECTION
Engine continues to run when operator leaves seat with attachment clutch engaged	<ol style="list-style-type: none"> 1. Faulty operator-safety presence control system. 	<ol style="list-style-type: none"> 1. Check wiring, switches and connections. If not corrected, contact an authorized service center/department
Poor cut - uneven	<ol style="list-style-type: none"> 1. Worn, bent or loose blade. 2. Mower deck not level. 3. Buildup of grass, leaves, and trash under mower 4. Bent blade mandrel. 5. Clogged mower deck vent holes from buildup of grass, leaves, and trash around mandrels. 	<ol style="list-style-type: none"> 1. Replace blade. Tighten blade bolt. 2. Level mower deck. 3. Clean underside of mower housing. 4. Replace blade mandrel. 5. Clean around mandrels to open vent holes.
Mower blades will not rotate	<ol style="list-style-type: none"> 1. Obstruction in clutch mechanism. 2. Worn/damaged mower drive belt. 3. Frozen idler pulley. 4. Frozen blade mandrel. 	<ol style="list-style-type: none"> 1. Remove obstruction. 2. Replace mower drive belt. 3. Replace idler pulley. 4. Replace blade mandrel.
Poor grass discharge	<ol style="list-style-type: none"> 1. Engine speed too slow. 2. Travel speed too fast 3. Wet grass. 4. Mower deck not level. 5. Low/uneven tire air pressure. 6. Worn, bent or loose blade 7. Buildup of grass, leaves and trash under mower. 8. Mower drive belt worn. 9. Blades improperly installed. 10. Improper blades used. 11. Clogged mower deck vent holes from buildup of grass, leaves, and trash around mandrels. 	<ol style="list-style-type: none"> 1. Place throttle control in "FAST" position. 2. Shift to slower speed. 3. Allow grass to dry before mowing. 4. Level mower deck. 5. Check tires for proper air pressure. 6. Replace/sharpen blade. Tighten blade bolt. 7. Clean underside of mower housing. 8. Replace mower drive belt. 9. Reinstall blades sharp edge down 10. Replace with blades listed in this manual 11. Clean around mandrels to open vent holes.
Headlight(s) not working (if so equipped)	<ol style="list-style-type: none"> 1. Switch is "OFF". 2. Bulb(s) burned out 3. Faulty light switch 4. Loose or damaged wiring. 5. Blown fuse 	<ol style="list-style-type: none"> 1. Turn switch "ON". 2. Replace bulb(s). 3. Check/replace light switch. 4. Check wiring and connections 5. Replace fuse.
Battery will not charge	<ol style="list-style-type: none"> 1. Bad battery cell(s). 2. Poor cable connections 3. Faulty regulator (if so equipped). 4. Faulty alternator. 	<ol style="list-style-type: none"> 1. Replace battery. 2. Check/clean all connections. 3. Replace regulator. 4. Replace alternator.
Loss of drive	<ol style="list-style-type: none"> 1. Freewheel control in "disengaged" position. 2. Motion drive belt worn, damaged, or broken. 3. Air trapped in transmission during shipment or servicing. 	<ol style="list-style-type: none"> 1. Place freewheel control in "engaged" position. 2. Replace motion drive belt. 3. Purge transmission.
Engine "backfires" when turning engine "OFF"	<ol style="list-style-type: none"> 1. Engine throttle control not set at "SLOW" position for 30 seconds before stopping engine 	<ol style="list-style-type: none"> 1. Move throttle control to "SLOW" position and allow to idle for 30 seconds before stopping engine.

TRACTOR -- MODEL NUMBER 917.258911

SCHEMATIC

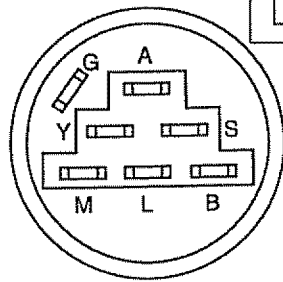
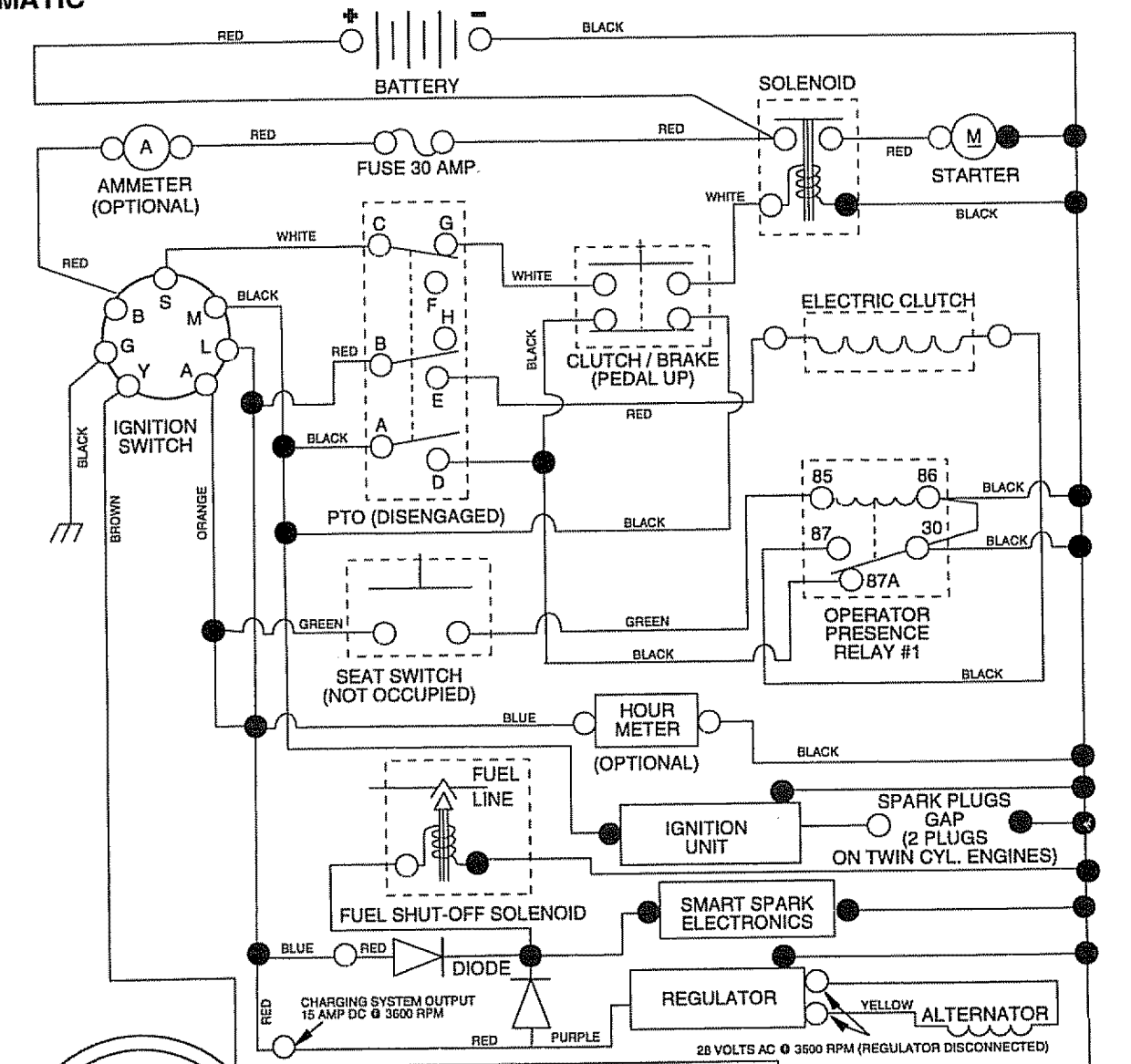

IGNITION SWITCH

POSITION	CIRCUIT	"MAKE"
OFF	G + M + L	NONE
RUN/LIGHT	B + L	A + Y
RUN	B + L	NONE
START	B + L + S	NONE

WIRING INSULATED CLIPS
NOTE: IF WIRING INSULATED CLIPS WERE REMOVED FOR SERVICING OF UNIT, THEY SHOULD BE REPLACED TO PROPERLY SECURE YOUR WIRING.

NOTE
 YOUR TRACTOR IS EQUIPPED WITH A SPECIAL ALTERNATOR SYSTEM. THE LIGHTS ARE NOT CONNECTED TO THE BATTERY, BUT HAVE THEIR OWN ELECTRICAL SOURCE. BECAUSE OF THIS, THE BRIGHTNESS OF THE LIGHTS WILL CHANGE WITH ENGINE SPEED. AT IDLE THE LIGHTS WILL DIM. AS THE ENGINE IS SPEEDED UP, THE LIGHTS WILL BECOME THEIR BRIGHTEST.

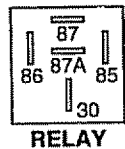

RELAY

PTO SWITCH	
POSITION	CIRCUIT
OFF	C + G, B + H
ON	C + F, B + E, A + D

REMOVABLE CONNECTIONS

NON-REMOVABLE CONNECTIONS

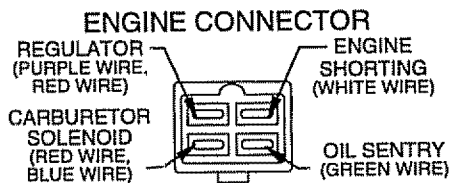

ENGINE CONNECTOR

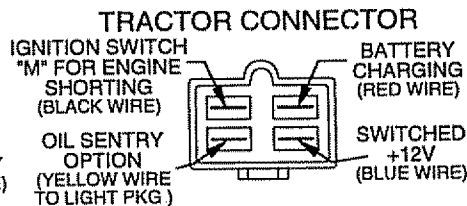

TRACTOR CONNECTOR

REPAIR PARTS

TRACTOR -- MODEL NUMBER 917.258911

ELECTRICAL

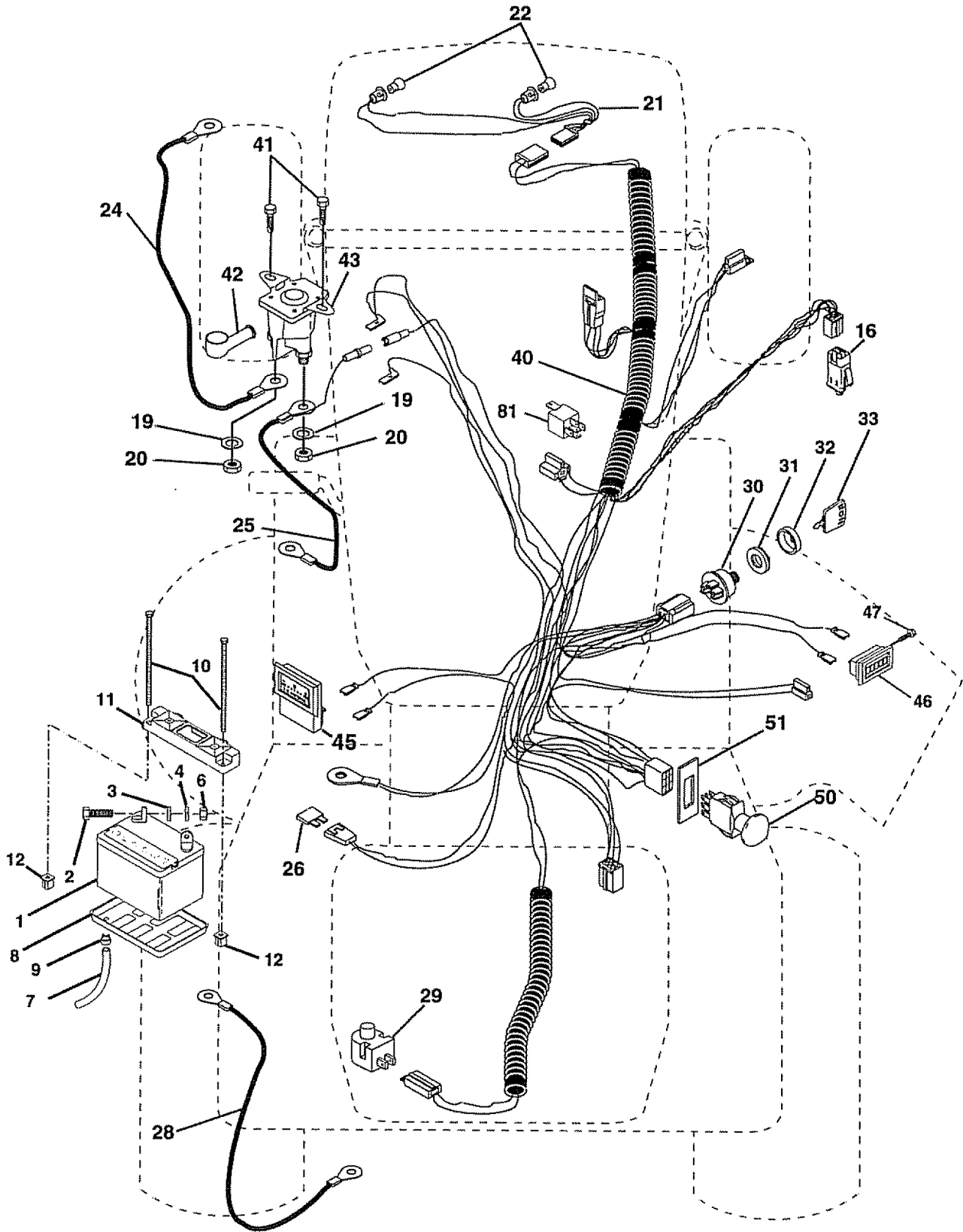

REPAIR PARTS

TRACTOR - - MODEL NUMBER 917.258911

ELECTRICAL

KEY NO.	PART NO.	DESCRIPTION
1	144927	Battery
2	74760412	Bolt Hex Head 1/4-20 x 3/4
3	STD551125	Washer, Lock 1/4
4	STD551025	Washer 9/32 x 5/8 x 16 Ga
6	STD541025	Nut Fin Hex 1/4-20
7	7697J	Tube Plastic
8	7603J	Tray, Battery
9	109596X	Clamp, Hose
10	145211	Bolt Wet BTR 1/4-20 x 7.5 Zinc
11	150109	Hold down Battery Front Mount
12	145769	Nut Push Nylon 1/4" Wet Battery
16	153664	Switch Interlock Push-In
19	STD551125	Washer, Lock 1/4
20	73350400	Nut, Jam Hex 1/4-20
21	136850	Harness Socket Light W/4152J
22	4152J	Bulb Light
24	4014J	Cable Battery 4 Ga. 22" Red
25	146686	Cable Battery Red 4 Ga. w/16 Wire
26	108824X	Fuse
28	157899	Cable Battery 4 Gauge 3/8 Term
29	160784	Switch, Plunger
30	140301	Switch, Ign
31	124211X	Nut, Ignition Switch
32	141226	Cover Switch Key
33	109310X	Key
40	160732	Harness Ign.
41	17720408	Screw 1/4-20 x 1/2
42	131563	Cover, Terminal Red
43	145673	Solenoid
45	122822X	Ammeter
46	110940X	Meter, Hour
47	17011008	Screw
50	154963	Switch, PTO
51	140405	Ring Retainer PTO
81	109748X	Relay Asm.

NOTE: All component dimensions given in U.S. inches
1 inch = 25.4 mm

REPAIR PARTS

TRACTOR - - MODEL NUMBER 917.258911

CHASSIS AND ENCLOSURES

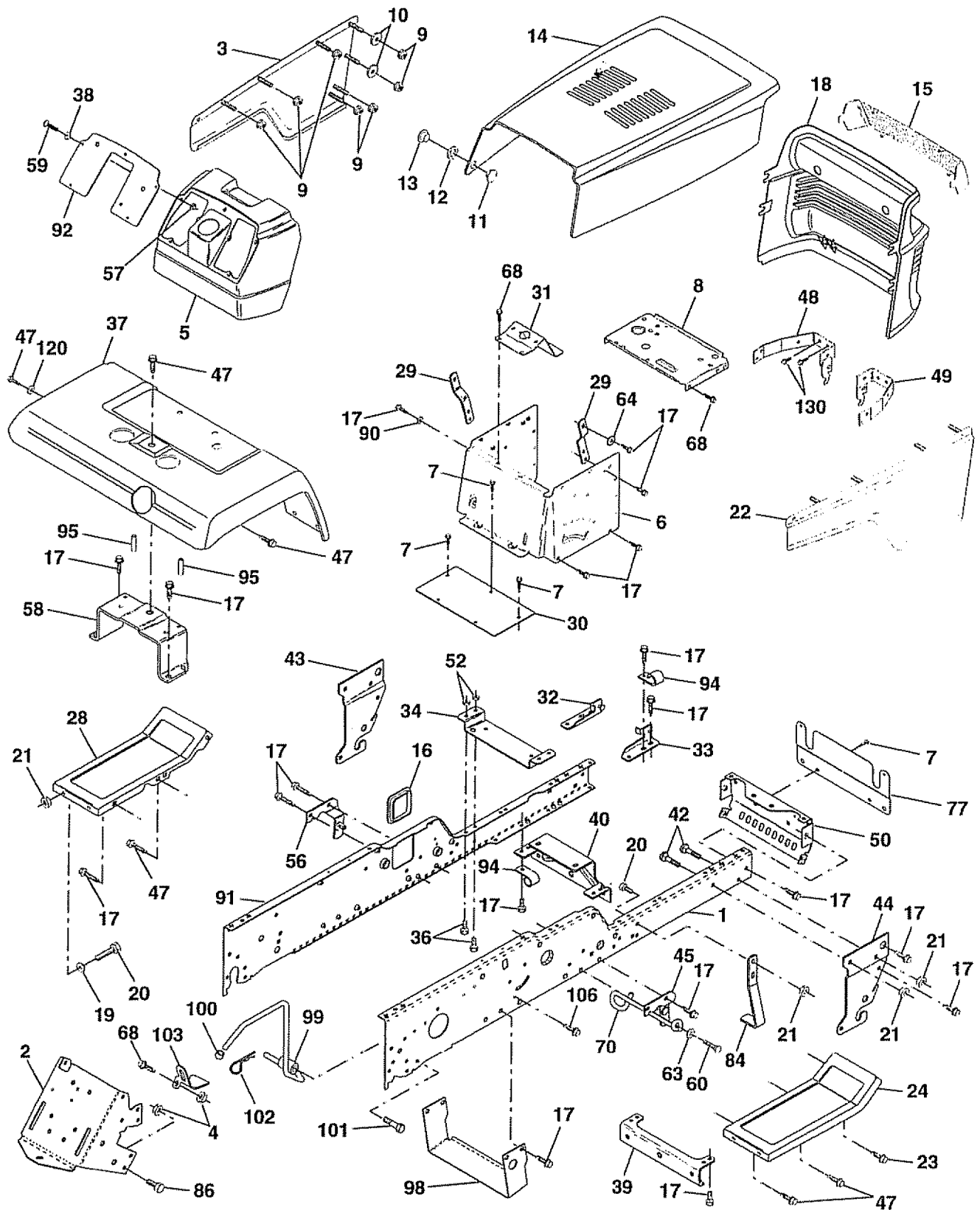

REPAIR PARTS

TRACTOR - - MODEL NUMBER 917.258911

CHASSIS AND ENCLOSURES

KEY NO.	PART NO.	DESCRIPTION	KEY NO.	PART NO.	DESCRIPTION
1	150253	Rail, Frame RH	43	136939	Bracket, Spnsn Front Lh
2	140506	Drawbar, Gt	44	136940	Bracket, Spnsn Front Rh
3	136671X558	Panel Asm., Side LH	45	154913	Bracket Asm., Susp Chassis Rh
4	73800700	Nut, Lock Hex 7/16 Unc	47	17490608	Screw Thdrol 3/8-16 x 1/2
5	145203	Dash, Plastic Black	48	157105	Bracket Asm., Pivot Hood Lh
6	157882	Dash Asm., Lower	49	157107	Bracket Asm., Pivot Hood Rh
7	17720408	Screw, Thd Cut 1/4-20 x 1/2	50	152728	Bracket, Chassis Front
8	145166	Support, Battery	52	STD541431	Nut, Crownlock 5/16-18
9	108067X	Nut, Pal	56	154914	Bracket Asm., Susp Chassis Lh
10	19092016	Washer 9/32 x 1-1/4 x 16 Ga.	57	73640400	Nut, Keps Hex 1/4-20
11	137270	Rivet, Ratchet Male	58	137113	Bracket Asm., Fender
12	137269	Washer, Nylon	59	74180412	Screw, Mach Cr 1/4-20 x 3/4
13	137271	Rivet, Ratchet Female	60	17490620	Screw Thdrol 3/8-16 x 1-1/4
14	136673X558	Hood Asm., Pnt	63	19131614	Washer 13/32 x 1 x 14 Ga.
15	136374	Lens, Bar Clear	64	144283	Washer, Serrated Disc 13/32 x 1
16	121794X	Cover, Access	68	17490508	Screw, Thd 5/16-18 x 1/2
17	17490612	Screw, Thdrol 3/8-16 x 3/4	70	137159	Guide, Belt Mid Span
18	136373X428	Grille	77	137308	Shield, Front
19	19131312	Washer 13/32 x 13/16 x 12 Ga.	84	142992	Stop, Over Center Mower
20	STD523710	Bolt, Fin Hex 3/8-16 x 1	86	74760716	Bolt, Fin Hex 7/16-14 Unc x 1
21	STD541437	Nut, Crownlock 3/8-16 Unc	90	STD551237	Washer, Lock External Tooth 3/8
22	136670X558	Panel Asm., Side RH	91	156586	Rail, Frame Lh
23	17490616	Screw Thdrol 3/8-16 x 1 Ty-Tt	92	156282X011	Plate, Silkscreen Dash
24	145243X558	Footrest, RH	94	100207K	Clip, Fuel Line
28	145244X558	Footrest, LH	95	105531X	Push Nut, Nylon
29	145349	Bracket, Support Dash	98	140503	Bracket Skid Chassis
30	145052	Saddle, Hydro 1995	99	140871	Rod By Pass
31	145183	Brace, Support Steering	100	124236X	Cap By Pass Rod
32	141315	Bracket Asm., Frame Pivot Lh	101	17490628	Screw Thdrol 3/8-16 x 1-3/4
33	141314	Bracket Asm., Frame Pivot Rh	102	STD624003	Retainer, Spring
34	142131	Bracket, Engine Support Rear	103	142273	Lock, By Pass
36	74780512	Bolt, Fin Hex 5/16-18 x 3/4	106	138776	Bolt 5/16-18 Type TT
37	140002X558	Fender, Pnt.	120	19131616	Washer 13/32 x 1 x 16 Ga.
38	STD551025	Washer 9/32 x 3/4 x 16 Ga.	130	17521312	Screw Sltd Hex Hd W/Pln Washer
39	136961	Bracket, Axle Front	--	8022J	Plug, Hole
40	156111	Bracket, Support Axle/Engine			
42	STD533710	Bolt, Carriage 3/8-16 x 1			

NOTE: All component dimensions given in U.S. inches
1 inch = 25.4 mm

REPAIR PARTS

TRACTOR - - MODEL NUMBER 917.258911

GROUND DRIVE

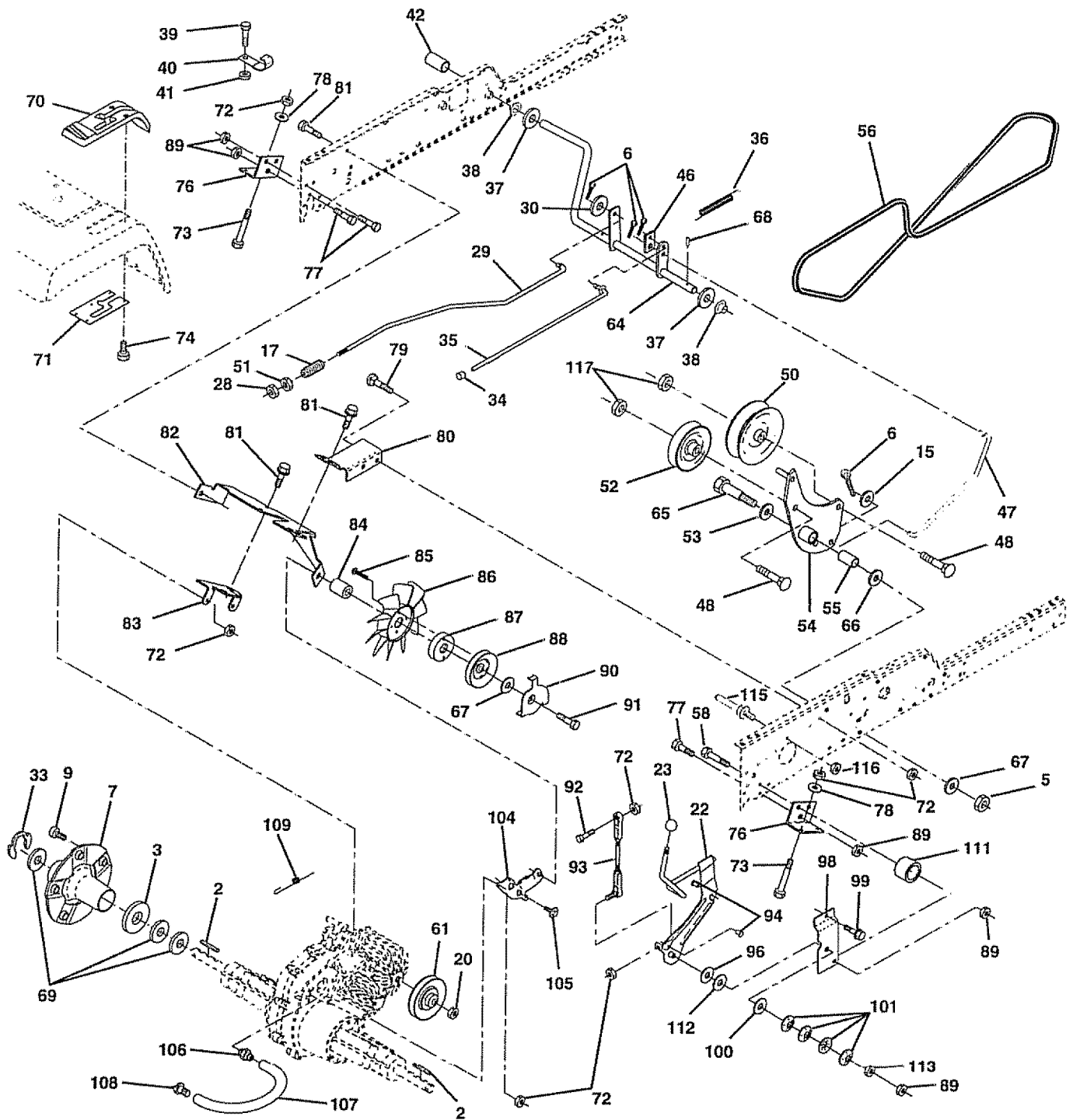

REPAIR PARTS

TRACTOR - - MODEL NUMBER 917.258911

GROUND DRIVE

KEY NO.	PART NO.	DESCRIPTION	KEY NO.	PART NO.	DESCRIPTION
2	7070E	Key 1/4 x 2.5	72	STD541431	Locknut Hex W/Washer Insert
3	7563R	Washer Thrust Axle Harden	73	74780548	Bolt Fin Hex 5/16-18 x 3
5	STD541437	Nut Crownlock 3/8-16	74	142432	Screw Hex Wsh. Hi-Lo 1/4-1/2
6	STD561210	Pin Cotter 1/8 x 3/4	76	140481	Bracket Transaxle
7	140507	Wheel Hub Asm.	77	74760716	Bolt Fin Hex 7/16-14 x 1
9	140080	Bolt Hub	78	19111212	Washer 11/32 x 3/4 x 12 Ga
15	STD551037	Washer 13/32 x 13/16 x 16 Ga	79	72110505	Bolt Carriage 5/16-18 x 5/8
17	140921	Spring Rod Brake	80	140484	Bracket Torque RH
20	73940800	Nut Hex Jam Toplock 1/2-20	81	17490612	Screw Thdrol 3/8-16 x 3/4
22	156103	Shift Arm Asm	82	150586	Bracket Mount Torque/Fan
23	130564	Knob	83	140479	Strap Torque Mid
28	STD541237	Nut	84	140490	Spacer
29	140494	Brake Rod	85	17541020	Screw #10-24 x 1-1/4
30	19131616	Washer 13/32 x 1 x 16 Ga.	86	140462	Fan 7" Hydro
32	73220700	Nut Hex 7/16-14	87	140491	Adapter Fan
33	12000053	Ring E	88	140492	Pulley Idler
34	124236X	Cap Parking Brake	89	73680700	Nut Crownlock 7/16-14 UNC
35	137648	Rod Parking Brake	90	140489	Keeper Belt
36	149412	Spring Drive Ground	91	17490644	Screw Thdrol 3/8-16 x 2-3/4
37	121749X	Washer 25/32 x 1-1/4 x 16 Gauge	92	74760520	Bolt Fin Hex 5/16-18 x 1.25
38	150035	Nyliner	93	140502	Link Shift Asm
39	74321016	Screw Fin #10-24 x 1	94	133835	Fastner Christmas Tree
40	5304J	Actuator Interlock Switch	95	23200528	Screw Set 5/16-18 x 1.5
41	73631000	Nut Lock #10-24	96	141103	Washer Nickel Plated
42	8883R	Cover Pedal	97	126874X	Bearing Trust
43	74760412	Bolt Hex Head 1/4-20 x 3/4	98	141004	Bracket Shift
44	104601X	Bracket Interlock	99	17490624	Screw Thdrol 3/8-16 x 1-1/2
45	73800400	Nut Lock W/Insert 1/4-20	100	126881X	Washer Compression
46	145170	Retainer Spring	101	156106	Washer Bellville
47	138228	Clutch Rod	102	73560500	Nut Hex Nylok
48	72110612	Bolt Carriage 3/8-16 x 1-1/2 Gr 5	103	73350500	Nut Hex Jam 5/16-18
50	131494	Pulley Idler Flat	104	140480	Bracket Idler
51	STD541437	Nut Crownlock 3/8-16 UNC	105	17580408	Screw Tap 1/4-20 x 1/2
52	139123	Pulley Idler Grooved	106	142918	O-Ring
53	207J	Washer Hardened	107	154739	Line Fuel
54	156563	Arm Asm Idler Clutch	108	142917	Cap Vent Hose
55	105706X	Bearing, Idler	109	140929	Spring Return Brake
56	140218	V-Belt	110	88652	Bolt
58	74760724	Bolt Fin Hex 7/16-14 x 1-1/2	111	156240	Spacer Shift Lever Vgth
61	140488	Pulley Input	112	156104	Washer Nylon High Temp
64	154752	Shaft Asm Brake Parking Clutch	113	73220700	Nut Hex ASF 7/16-14 UNC
65	67609	Bolt Shoulder	115	123405X	Keeper Belt T/A Gnd. Dr.
66	140296	Washer Hardened	116	73900500	Nut Lock Hex Flange 5/16-18
67	19131312	Washer 13/32 x 13/16 x 12 Ga	117	73900600	Nut Lock Flange 3/8-16 UNC
68	5142H	Pin Roll	--	150073	Transaxle (See Breakdown) Hydro Gear 218-3010
69	123800X	Washer			
70	151146	Console Hydro Fender			
71	151179	Plate Console Shift			

NOTE: All component dimensions given in U.S. inches
1 inch = 25.4 mm

REPAIR PARTS

TRACTOR - - MODEL NUMBER 917.258911

STEERING ASSEMBLY

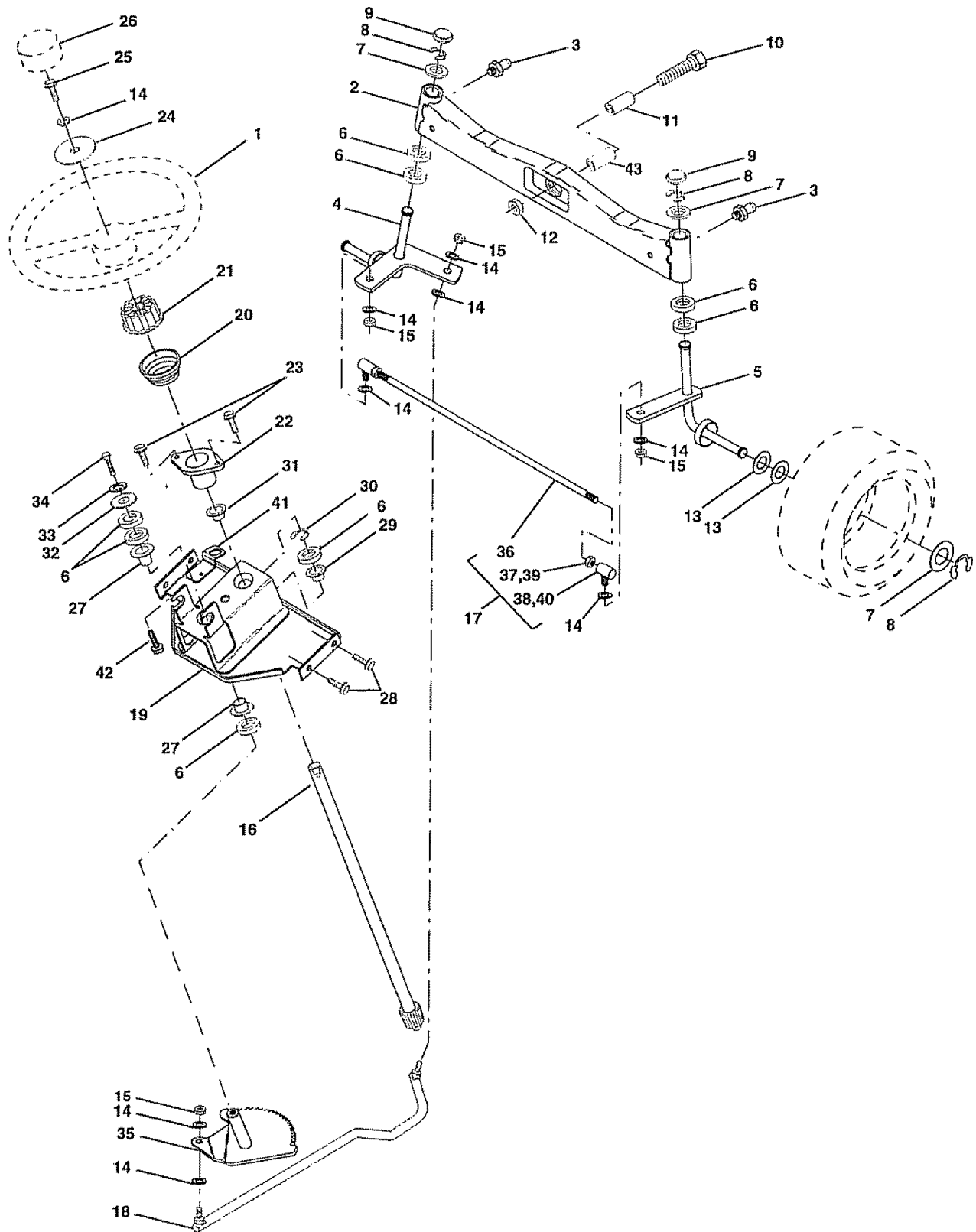

REPAIR PARTS

TRACTOR - - MODEL NUMBER 917.258911

STEERING ASSEMBLY

KEY NO.	PART NO.	DESCRIPTION
1	121472X	Wheel, Steering
2	137094	Axle Asm., Front
3	6855M	Fitting, Grease
4	136960	Spindle Asm, LH
5	136959	Spindle Asm., RH
6	6266H	Bearing, Race Thrust Harden
7	121748X	Washer 25/32 x 1-5/8 x 16 Ga.
8	12000029	Ring, Klip #T5304-75
9	121232X	Cap, Spindle
10	74781044	Bolt, Fin Hex 5/8-11 x 2-3/4
11	154779	Bearing Axle STLT/GT
12	73901000	Nut, Lock Flange 5/8-11 Unc
13	121749X	Washer 25/32 x 1-1/4 x 16 Ga.
14	STD551137	Washer, Lock Hvy Hlcl Spr 3/8
15	STD541537	Nut Lock Center 3/8-24 UNF
16	145103	Shaft Asm., Steering
17	137347	Rod Asm., Tie Ball J Ball Vgt (Inc. Key No. 36-40)
18	137155	Draglink, Ball Joint Solid Vgt
19	156011	Support Asm., Steering Vgt
20	145182	Column, Steering
21	100711L	Adapter, Wheel Steering
22	155105	Bushing, Strg. Blk
23	152927	Screw, TT #10-32.5.3/8. Flange
24	19133808	Washer 13/32 x 2-3/8 x 8 Ga.
25	STD523710	Bolt, Fin Hex 3/8-16 x 1 Gr. 5
26	126805X	Cap, Wheel Steering
27	3366R	Bearing, Col. Strg.
28	17490612	Screw, Thrdrol 3/8-16 x 3/4
29	104239X	Bearing, Flange
30	12000034	Ring, Klip Truarc #5304-75
31	138136	Bushing, Nylon Snap
32	19111610	Washer 11/32 x 1 x 10 Ga.
33	STD551131	Washer, Lock Hvy Hlcl Spr 5/16
34	STD523107	Bolt, Hex Hd 5/16-18 x 3/4
35	138059	Gear, Sector Steering
36	137156	Tie Rod
37	73360600	Jam Nut RH Thread
38	109850X	Joint Asm. Ball RH Thread
39	73700600	Jam Nut LH Thread
40	109851X	Joint Asm. Ball LH Thread
41	155246	Bracket Switch Interlock
42	17490508	Screw Thdrol 5/16-18 x 1/2 Tyt
43	154780	Spacer Axle

NOTE: All component dimensions given in U.S. inches
1 inch = 25.4 mm

REPAIR PARTS

TRACTOR - - MODEL NUMBER 917.258911

ENGINE

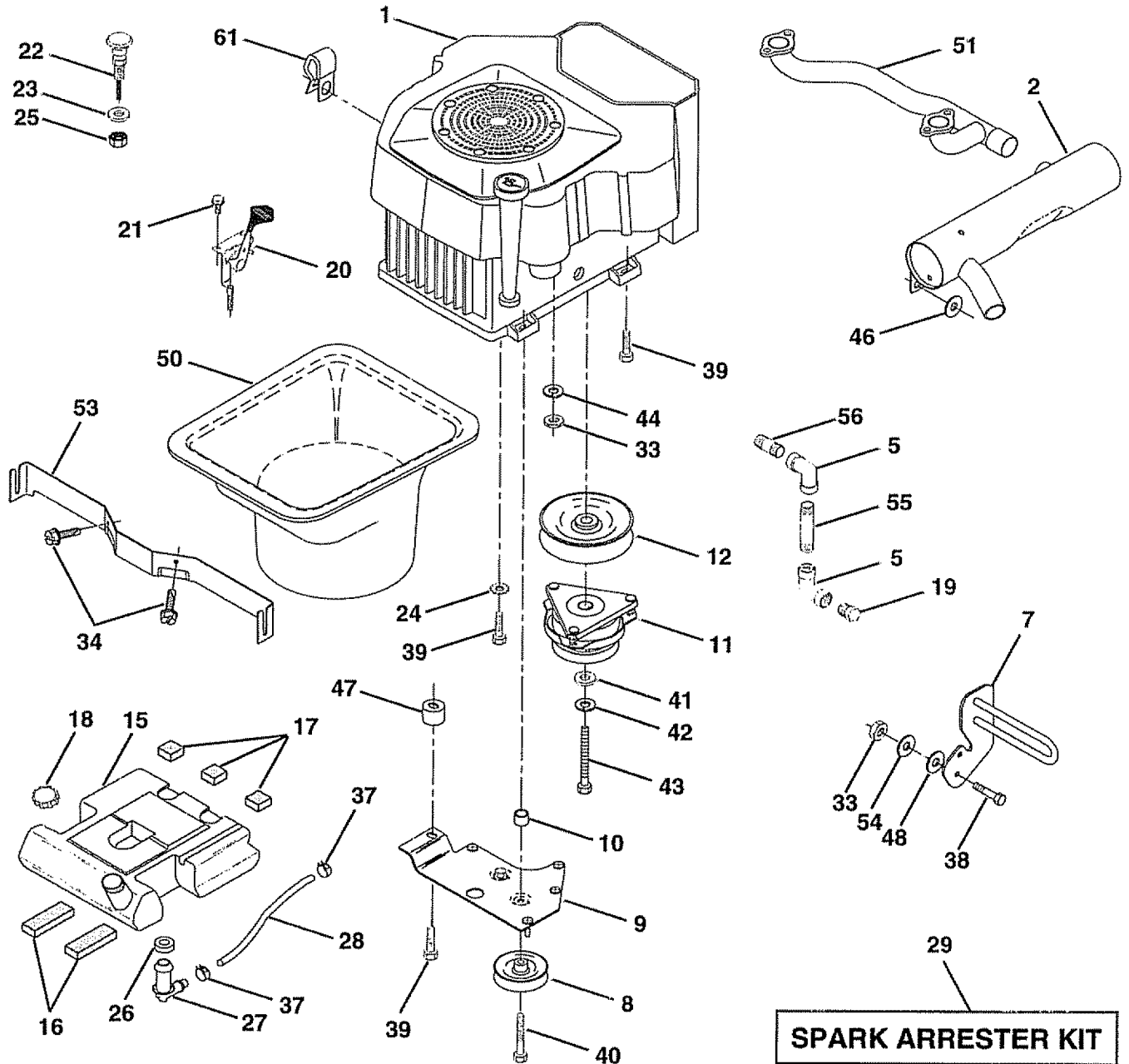

REPAIR PARTS

TRACTOR - - MODEL NUMBER 917.258911

ENGINE

KEY NO.	PART NO.	DESCRIPTION
1	-----	Engine (See Breakdown) Kohler Model CV22-PS67515
2	144636	Muffler Cylinder VGT (Inc. Key No. 34)
5	13200300	Elbow STD 90 Degree 3/8 - 18 NPT
7	151396	Muffler Assembly Guard
8	121361X	Pulley V-Idler
9	150828	Keeper Asm Belt Engine Vgt 96
10	105432X	Bushing
11	140923	Clutch Electric
12	143996	Pulley Engine
15	151346	Tank Fuel Rear 3.50 YT/GT
16	109227X	Pad Spacer
17	106082X	Pad Spacer
18	152334	Cap Asm Fuel W/Gauge
19	13290300	Plug Oil Drain (Order From Engine Manufacturer)
20	132755	Control Throttle
21	17720410	Screw Hex Thd Cut 1/4 - 20 X 5/8
22	132779	Control Choke
23	19132616	Washer 13/32 X 1 - 5/8 X 16 Ga
24	STD551237	Lockwasher Ext Tooth 3/8
25	73920600	Nut Keps 3/8 - 24 UNF
26	3645J	Bushing
27	139277	Stem Tank Fuel
28	7834R	Fuel Line
29	132920	Spark Arrester Kit
33	STD541437	Nut Lock Hex w/Ins 3/8-16 Unc
34	17720408	Screw Thd Cut 1/4-20 x 1/2 Ty23
37	123487X	Clamp Hose
38	74780624	Bolt Fin Hex 3/8-16 Unc x 1-1/2
39	17490636	Screw Tt 3/8-16 x 2-1/4 Unc
40	17490664	Screw Tt 3/8-16 x 4 Unc
41	126197X	Washer 1-1/2 OD X 15/32 ID X .250
42	10040700	Washer Lock 7/16
43	150280	Bolt Hex 7/16-20 X 4-1/4 Ga 5
45	128861	Nut Flange 1/4-20 Starter Nut
46	19131616	Washer 13/32 x 1 x 16 Ga.
47	142040	Spacer Engine CV22 Round Pm
48	19132007	Washer 13/32 x 1-1/4 x 7 Ga.
50	143020	Duct Air VGT Sears Kohler CV22
51	140787	Pipe Crossover CV22
53	143528	Bracket Duct Air Rear Support
54	19131414	Washer Flat 13/32 x 7/8 x 14 Ga.
55	13280336	Nipple Pipe 4-1/2
56	13090308	Nipple Pipe 3/8 Npt x 1.00
61	2751R	Clip Line Fuel

NOTE: All component dimensions given in U.S. inches
1 inch = 25.4 mm

REPAIR PARTS

TRACTOR - - MODEL NUMBER 917.258911

SEAT ASSEMBLY

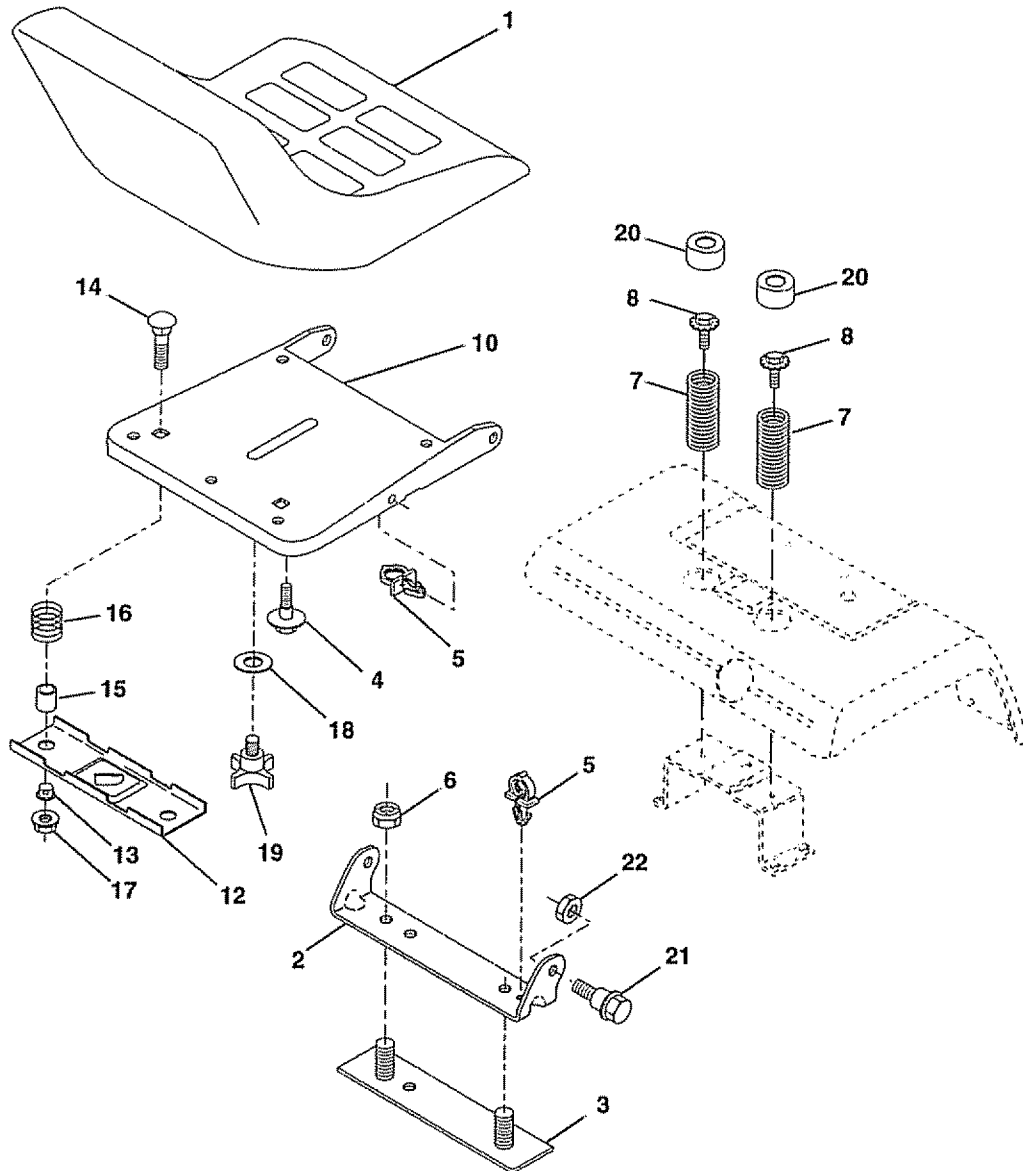

KEY NO.	PART NO.	DESCRIPTION	KEY NO.	PART NO.	DESCRIPTION
1	140124	Seat	14	72050411	Bolt, Carriage 1/4-20 X 1-3/8
2	140551	Bracket, Pivot Seat	15	121249X	Spacer, Split
3	140675	Strap, Fender	16	123740X	Spring, Cprsn
4	127018X	Bolt, Shoulder 5/16-18 X .62	17	123976X	Nut, Lock 1/4 Lge Flg Gr. 5
5	145006	Clip, Push In Hinged	18	19171912	Washer 17/32 X 1-3/16 X 12 Ga.
6	STD541437	Nut, Crownlock 3/8-16 Unc	19	120068X	Knob, Seat 1/2-13 Unc
7	124181X	Spring, Seat Cprsn	20	124238X	Cap, Spring Seat
8	150176	Bolt 5/16-18 UNC x 3/4 w/Sem	21	153236	Bolt, Shoulder 5/16-18 Unc
10	155925	Pan, Seat	22	STD541431	Nut, Crownlock 5/16-18 Unc
12	121246X	Bracket, Mounting Switch			
13	121248X	Bushing, Snap			

NOTE: All component dimensions given in U.S. inches
1 inch = 25.4 mm

REPAIR PARTS

TRACTOR - - MODEL NUMBER 917.258911

DECALS

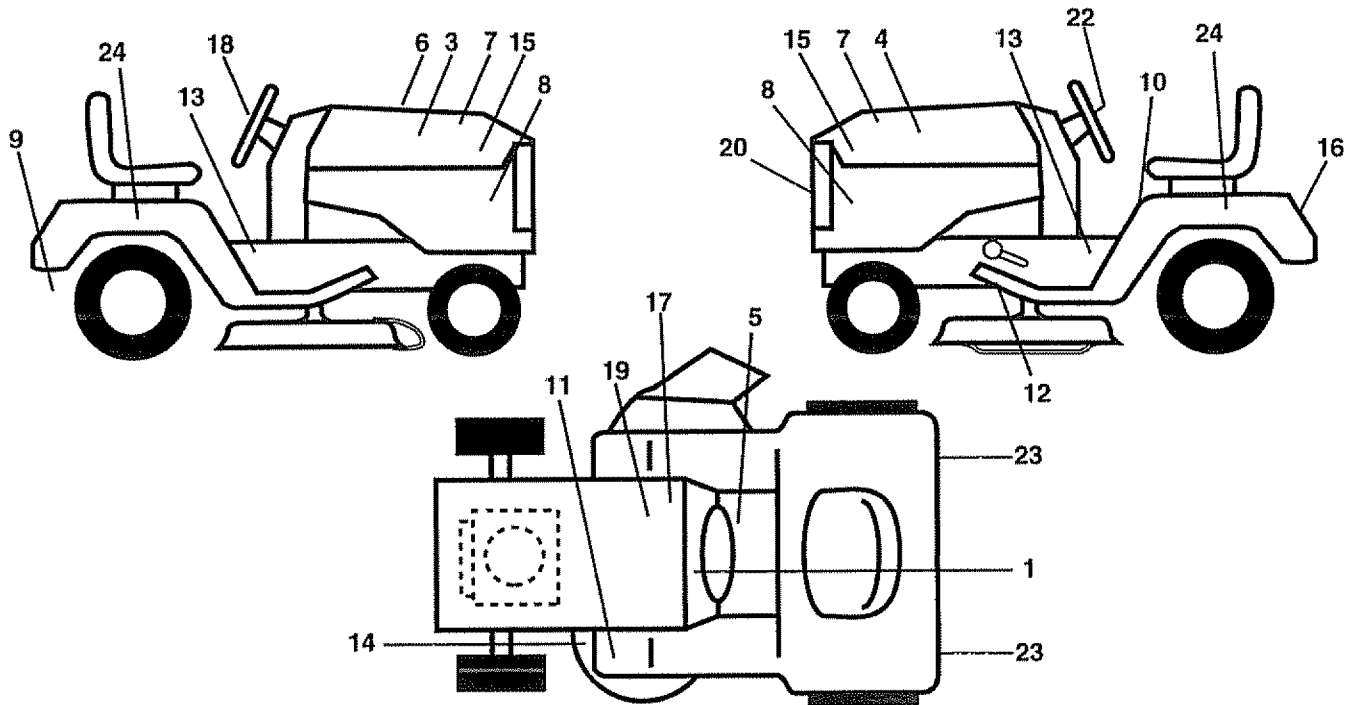

KEY NO.	PART NO.	DESCRIPTION	KEY NO.	PART NO.	DESCRIPTION
1	156835	Decal, Operating Instruction	16	146709	Decal, Fender
3	160298	Decal, Hood, Craftsman, RH	17	149516	Decal, Btry Dngr/Psn Eng. Acme
4	160299	Decal, Hood, Craftsman, LH	18	146710	Decal, Insert Strg
5	140837	Decal, Brake Parking Saddle	19	138047	Decal, Battery
6	133644	Decal, Maintenance	20	151448	Decal, Grille
7	138048	Decal, Side Panel	22	150333	Decal, Cap Cnsmr Help Line Srs
8	151568	Decal, Ins. Hood	23	106202X	Reflector, Taillight
9	142342	Decal, Control Movement	24	149918	Decal, Fender Hyd/Auto Gold Srs
10	156439	Decal, Danger	--	138311	Decal, Handle LFT Hieght Adj. (Lift Handle)
11	4900J	Decal, Clutch/Brake	--	145246	Pad Footrest
12	139346	Decal, V-Belt Drive Schematic	--	145247	Fastener Pop-in Footrest
13	146711	Decal, Chassis, Hydro 50"	--	160994	Manual, Owner's (Eng)
14	160397	Decal, V-Belt Schematic	--	160995	Manual, Owner's (Span)
15	142241	Decal, Panel Side			

WHEELS & TIRES

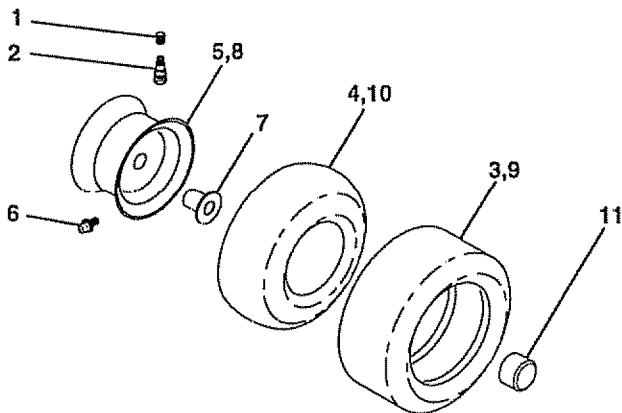

KEY NO.	PART NO.	DESCRIPTION
1	59192	Cap, Valve, Tire
2	65139	Stem, Valve
3	148741	Tire, Front
4	8134H	Tube, Front (Service Item Only)
5	148736X427	Rim Assembly, Front
6	278H	Fitting, Grease
7	9040H	Bearing, Flange (Front Wheel Only)
8	148738X427	Rim Assembly, Rear
9	151607	Tire, Rear
10	7154J	Tube, Rear
11	104757X	Cap Hub Axle BLK 1.50 x 1.00
--	144334	Sealant, Tire (10 oz. tube)

NOTE: All component dimensions given in U.S. inches
1 inch = 25.4 mm

REPAIR PARTS

TRACTOR - - MODEL NUMBER 917.258911

LIFT ASSEMBLY

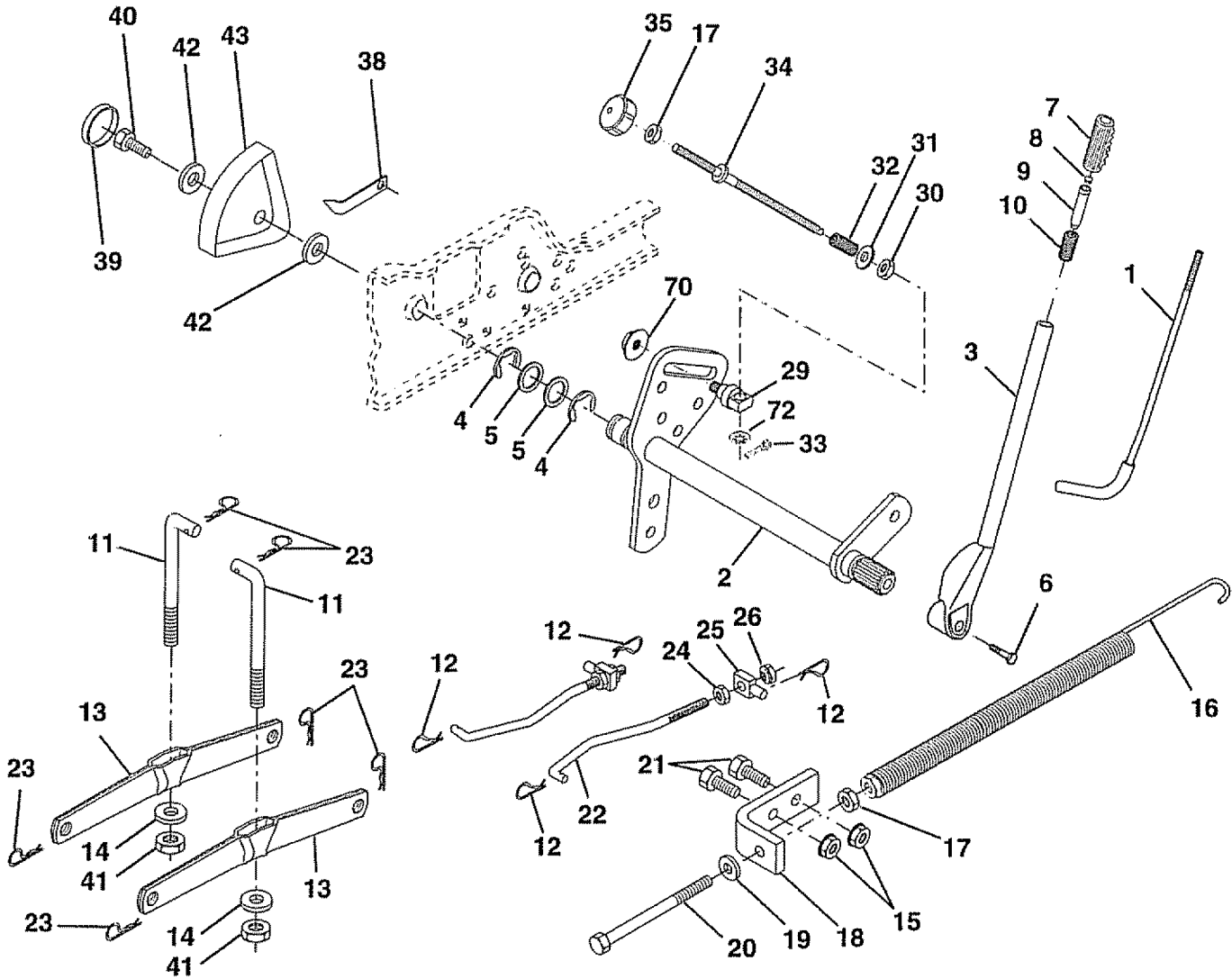

REPAIR PARTS

TRACTOR - - MODEL NUMBER 917.258911

LIFT ASSEMBLY

KEY NO.	PART NO.	DESCRIPTION
1	121006X	Rod Asm., Lever
2	154389	Shaft Asm., Lift Vgt
3	121002X	Lever Asm., Lift Rh
4	12000022	E-Ring Truarc #5133-87
5	19292016	Washer 29/32 x 1-1/4 x 16 Ga.
6	74780624	Bolt, Fin Hex 3/8-16 x 1-1/2
7	125631X	Grip, Handle Fluted
8	122365X	Button, Plunger
9	122364X	Plunger, Lever Lift
10	2876H	Spring 2-1/8"
11	146704	Link Lift
12	STD624008	Retainer, Spring
13	139868	Arm, Suspension Vgt
14	140302	Bearing, Pvt. Lift Spherical
15	STD541437	Nut, Crownlock 3/8-16 Unc
16	674A247	Spring Asm., Assist Lift
17	STD541237	Nut, Hex Jam 3/8-16 Unc
18	143363	Bracket, Spring Assist
19	STD551037	Washer 13/32 x 13/16 x 16 Ga.
20	5328J	Bolt, Adjust Spring Assist
21	STD523710	Bolt, Fin Hex 3/8-16 x 1
22	127218	Link, Front
23	STD624008	Retainer, Spring
24	73350800	Nut, Jam Hex 1/2-13 Unc
25	130171	Trunnion
26	73800800	Nut, Lock W/Wsh 1/2-13 Unc
29	150233	Trunnion, Infin. Height
30	110807X	Nut, Special
31	19131016	Washer 13/32 x 5/8 x 16 Ga.
32	137150	Spring, Compression Inf Hgt
33	76020308	Pin, Cotter 3/32 x 1/2
34	137167	Rod, Adj Lift
35	138057	Knob, Inf 3/8-16 Unc
38	155097	Pointer, Pnt Height Indicator
39	123935X	Plug, Hole
40	17490512	Screw Thdrol 5/16-18 x 3/4
41	73540600	Nut, Crownlock 3/8-24
42	19112410	Washer 11/32 x 1-1/2 x 10 Ga.
43	123934X	Scale, Indicator Height
70	154212	Nut, Hex, Flange, Lock
72	110452X	Nut Push Phos & Oil

NOTE: All component dimensions given in U.S. inches
1 inch = 25.4 mm

REPAIR PARTS

TRACTOR - - MODEL NUMBER 917.258911

MOWER DECK

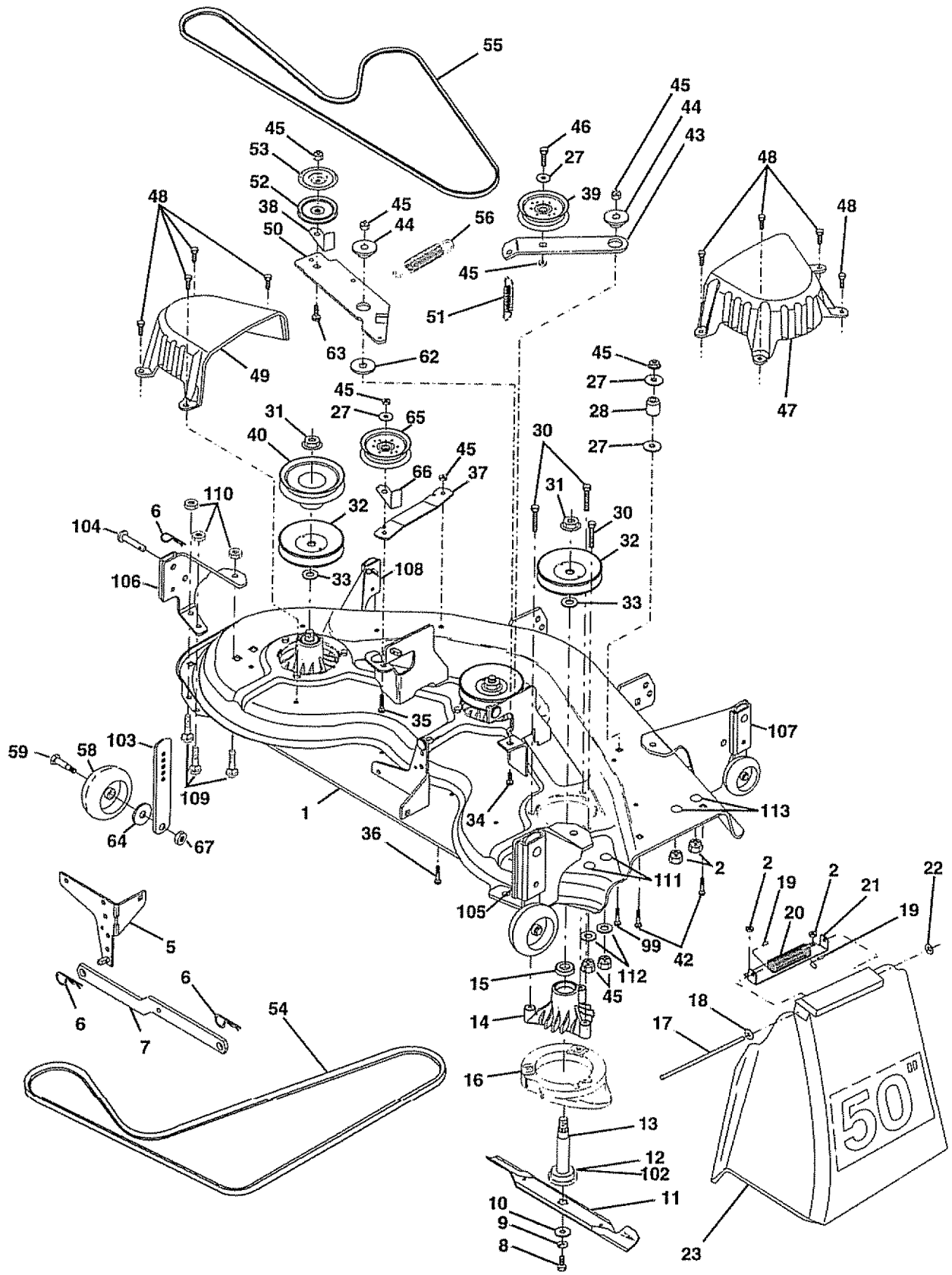

REPAIR PARTS

TRACTOR - - MODEL NUMBER 917.258911

MOWER DECK

KEY NO.	PART NO.	DESCRIPTION	KEY NO.	PART NO.	DESCRIPTION
1	156990	Mower Deck Weldment	46	74760628	Bolt, Fin Hex 3/8-16 Unc x 1-3/4
2	STD541431	Nut, Crownlock 5/16-18	47	137200	Cover, Mandrel RH
5	138457	Bracket Asm., Sway Bar	48	137729	Screw, Thd Roll 1/4-20 x 5/8
6	STD624008	Retainer, Spring	49	136574	Cover, Mandrel LH
7	130832	Arm Suspension, Rear	50	137272	Arm, Idler Primary
8	850857	Bolt 3/8-24 x 1.25 Gr. 8 Patched	51	137273	Spring, Secondary
9	STD551137	Washer, Lock Hvy 3/8 Unplated	52	139245	Pulley, Idler V Groove
10	140296	Washer, Hard Blade Mower Vented	53	137789	Shield, Idler
11	137380	Blade (3 Required)	54	139573	V-Belt, Mower Primary
12	129895	Bearing, Ball #6204 (Mandrel)	55	144959	V-Belt, Mower Secondary
13	137553	Shaft Asm., W/Lower Brg (Includes Key No. 12)	56	138687	Spring, Primary
14	137152	Housing, Mandrel 44" Vent	58	133957	Wheel, Gauge
15	110485X	Bearing, Ball Mandrel	59	137644	Bolt, Shoulder
16	140329	Stripper, Mower Round	62	133943	Washer Hardened
17	106735X	Rod, Hinge	63	72110612	Bolt Carriage 3/8-16 x 1-1/2
18	19111016	Washer 11/32 x 5/8 x 16 Ga.	64	19121414	Washer 3/8 x 3/4 x 14Ga
19	105304X	Cap, Sleeve	65	151831	Pulley, Flat, Idler5
20	123713X	Spring, Torsion Deflector	66	156009	Keeper, Belt, Idler
21	137607	Bracket, Deflector	67	73930600	Nut, Centerlock 3/8-16
22	110452X	Nut, Push	99	72110614	Bolt, Carriage 3/8-16 x 1-3/4 Gr. 5
23	110509X	Shield, Deflector Mower	102	153390	Felt Washer
27	STD551037	Washer 13/32 x 13/16 x 16 Ga.	103	155986	bar Adjusting Gauge Wheel
28	132823	Spacer, Spring Stop Idler	104	156941	Pin Head Pivot
30	157722	Screw Rolling Washer Head	105	156852	Bracket Pnt Ga. Wheel Asm R. RH 50
31	137266	Nut, Flg Top Lock Cntr 9/16	106	156853	Bracket Pnt Ga. Wheel Asm R. LH 50
32	153535	Pulley, Mandrel	107	156854	Bracket Pnt Ga. Wheel Asm F. RH 50
33	129963	Washer, Spacer Mower Vented	108	156856	Bracket Pnt Ga. Wheel Asm F. LH 50
34	72140610	Bolt, Carriage 3/8-16 x 1-1/4	109	72010505	Bolt Carriage 5/16-18 x 5/8 Blk.
35	72110616	Bolt, Carriage 3/8-16 x 2	110	73980500	Nut Crownlock 5/16-18 Blk.
36	72110608	Bolt, Carriage 3/8-16 x 1 Gr. 5	111	72110605	Bolt Carr. Sqnk 3/8-16 x 5/8 Gr. 5
37	137166	Stiffener, Arm Idler	113	72110504	Bolt Carriage 5/16 UNC x 1/2
38	156085	Keeper, Belt Idler	--	158325	Mower Service.
39	131494	Pulley, Idler Flat	--	143651	Mandrel Asm. (Includes Key Nos. 8-10, 12-15, 31, 33)
40	136572	Pulley, Driven			
42	STD533107	Bolt, Carriage 5/16-18 Unc x 3/4			
43	136460	Arm, Idler Secondary			
44	122052X	Spacer, Retainer			
45	STD541437	Nut, Crownlock 3/8-16 Unc			

NOTE: All component dimensions given in U.S. inches
1 inch = 25.4 mm

REPAIR PARTS

TRACTOR -- MODEL NUMBER 917.258911

HYDRO GEAR TRANSAXLE -- MODEL NUMBER 218-3010

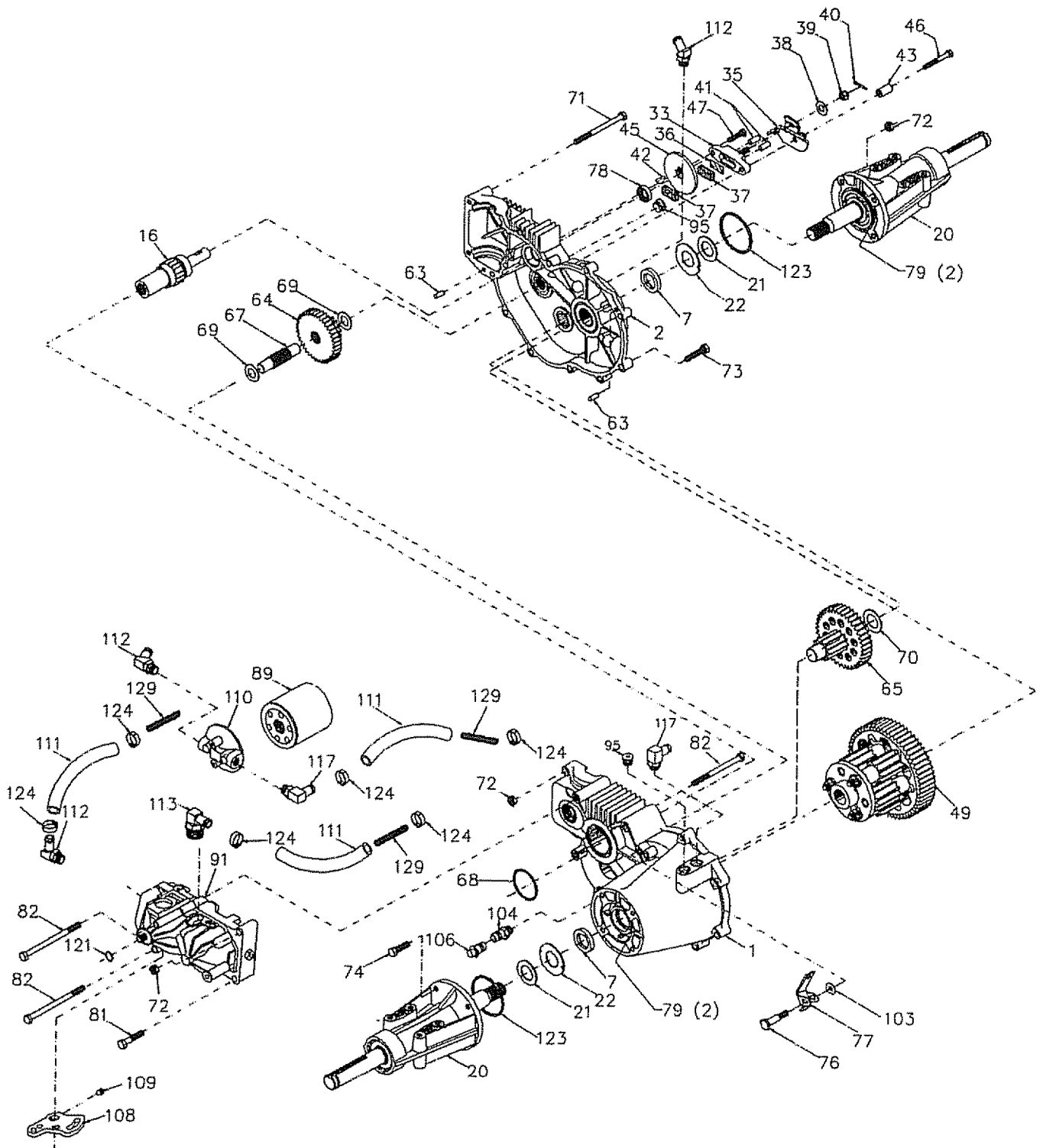

REPAIR PARTS

TRACTOR - - MODEL NUMBER 917.258911

HYDRO GEAR TRANSAXLE - - MODEL NUMBER 218-3010

KEY PART NO.	NO.	DESCRIPTION	KEY PART NO.	NO.	DESCRIPTION
1	142874	Assembly, Housing, LH	72	153767	Locknut, Hex 5/16-18
2	142875	Assembly, Housing, RH	73	142904	Bolt, Hex 5/16-18 x 1-1/2
7	153765	Oil Seal .984 x 1.5 x .25	74	142905	Hex Cap Screw 5/16-18 x 1
16	142876	Brake Shaft Assembly	76	142907	Shoulder Bolt
20	142877	Axle Mounting Horn Assembly	77	142908	Freewheel Actuating Arm
21	142878	Washer 1.0 x 1.63 x .08	78	142909	Oil Seal .625 x 1.0 x .25
22	142879	Washer 1.0 x 2.06 x .09	79	153768	Grease (10 oz. Tube)
33	142929	Brake Yoke Assembly	81	142910	Bolt, Hex 5/16-18 x 1-3/4
35	142880	Brake Arm	82	142911	Bolt 5/16-18 x 4-1/2
36	142882	Puck Plate	89	142912	Filter, Spin On
37	142883	Brake Puck	91	153769	Pump, BDU-10L-122
38	142884	Washer 7/8 O.D. x 7/16 x .060	95	142914	Plug, Straight Thread
39	142885	Nut, Castle 5/16-24	96	153770	60° 7/18 SAE x 5/16 Fitting
40	142886	Cotter Pin	103	142916	Washer
41	142887	Brake Actuating Pin	104	142917	Vent Cap Assembly
42	142888	Hi Pro Key	106	142918	Fitting O-Ring Assembly
43	142889	Spacer	108	142919	Control Arm
45	142890	Brake Disc	109	142920	Set Screw
46	142891	Bolt 1/4-20 x 1-1/2	110	142921	Filter Head
47	142892	Bolt 1/4-20 x 1	111	150820	Hose 1/2"
49	153766	Differential Assembly	112	150823	Fitting, 1/2" Beaded 90° 7/8 SAE
63	142894	Dowel Pin	113	150821	Fitting, 1/2" Beaded 60° 9/16
64	150818	Reduction Gear, 14 Teeth to 38 Teeth	117	150822	Fitting, 1/2" Beaded 90° 9/16
65	142897	Final Drive Pinion Assembly	123	150824	O Ring
67	142898	Jackshaft	124	150825	Pinch Clamp
68	142899	O-Ring	129	153771	Spring, Long
69	142900	Washer 5/8 X 1-5/32			
70	142901	Washer 7/8 X 1-1/2			
71	142902	Bolt, Hex 5/16-18 x 3.5			

NOTE: All component dimensions given in U.S. inches
1 inch = 25.4 mm

REPAIR PARTS

TRACTOR - - MODEL NUMBER 917.258911

HYDRO GEAR PUMP - MODEL NUMBER BU-10L-122

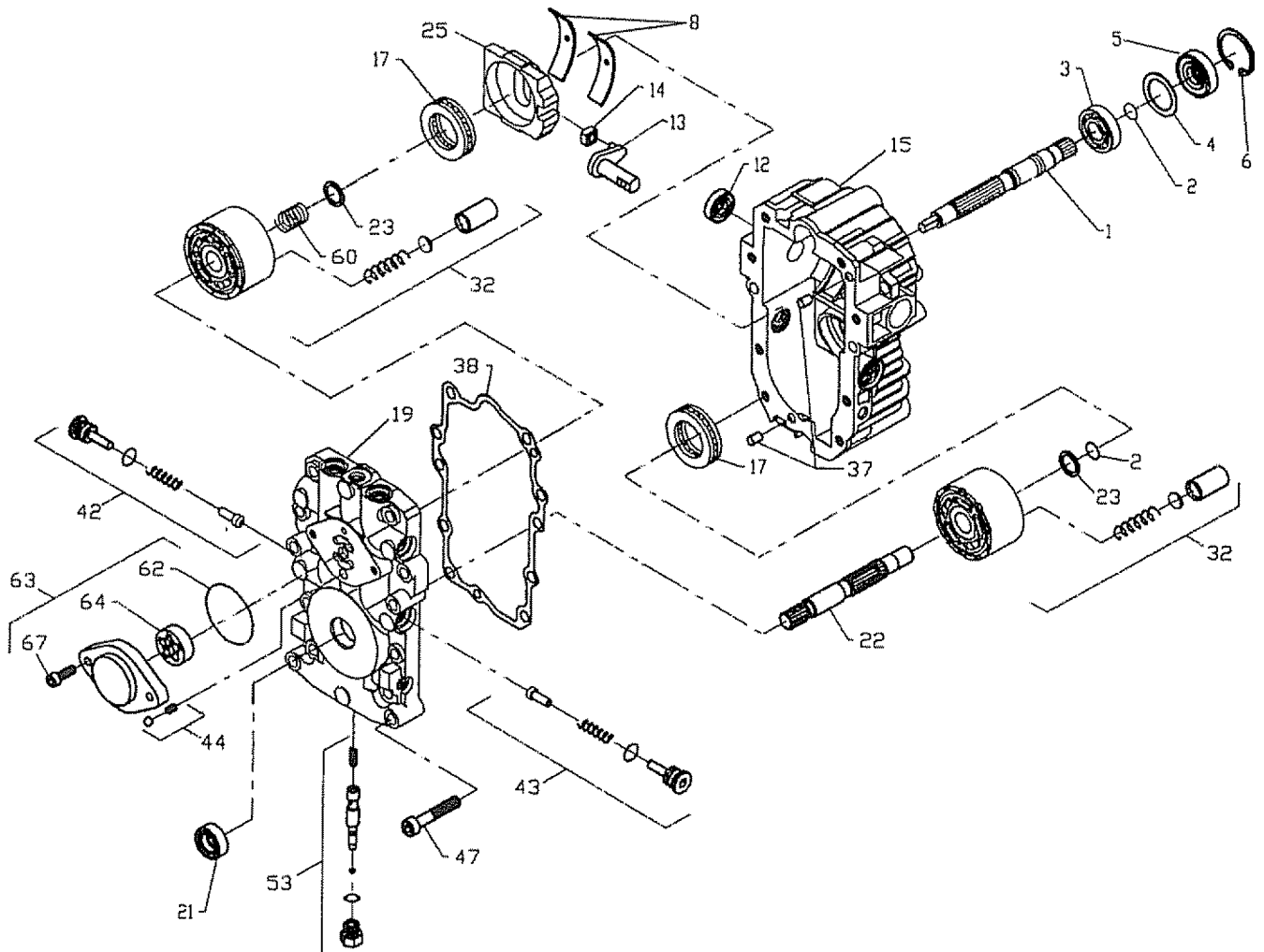

**KEY PART
NO. NO.**

DESCRIPTION

1	144569	Shaft, Pump
2	122716X	Ring, Retaining
3	122745X	Bearing, Ball
4	122715X	Spacer
5	122700X	Seal, Lip
6	122699X	Ring, Retaining
8	122767X	Bearing, Cradle
12	122717X	Seal, Lip
13	122748X	Arm, Trunnion
14	122749X	Guide, Slot
15	144571	Housing Kit, Transmission
17	122770X	Bearing, Thrust, Ball
19	153801	Center Section Kit
21	122722X	Seal, Lip
22	144573	Shaft, Motor
23	142978	Washer, Block Thrust

**KEY PART
NO. NO.**

DESCRIPTION

25	127148X	Swashplate, Variable
32	142938	Block Assembly
37	122786X	Pin, Stainless, Headless
38	122718X	Gasket, Center Section
42	144578	Check Valve Kit
43	144578	Check Valve Kit
44	144579	Charge Relief Kit
47	122752X	Screw, Socket Head, Cap
53	127153X	Bypass Valve Kit
60	142977	Block Spring
62	144581	O-Ring
63	144582	Charge Pump Kit
64	144583	Gerotor Assembly
67	144584	Screw, Socket Head, Cap
--	153769	Pump Assembly, Complete

REPAIR PARTS

TRACTOR - - MODEL NUMBER 917.258911

KOHLER ENGINE - MODEL NUMBER CV22S, TYPE NUMBER 67515

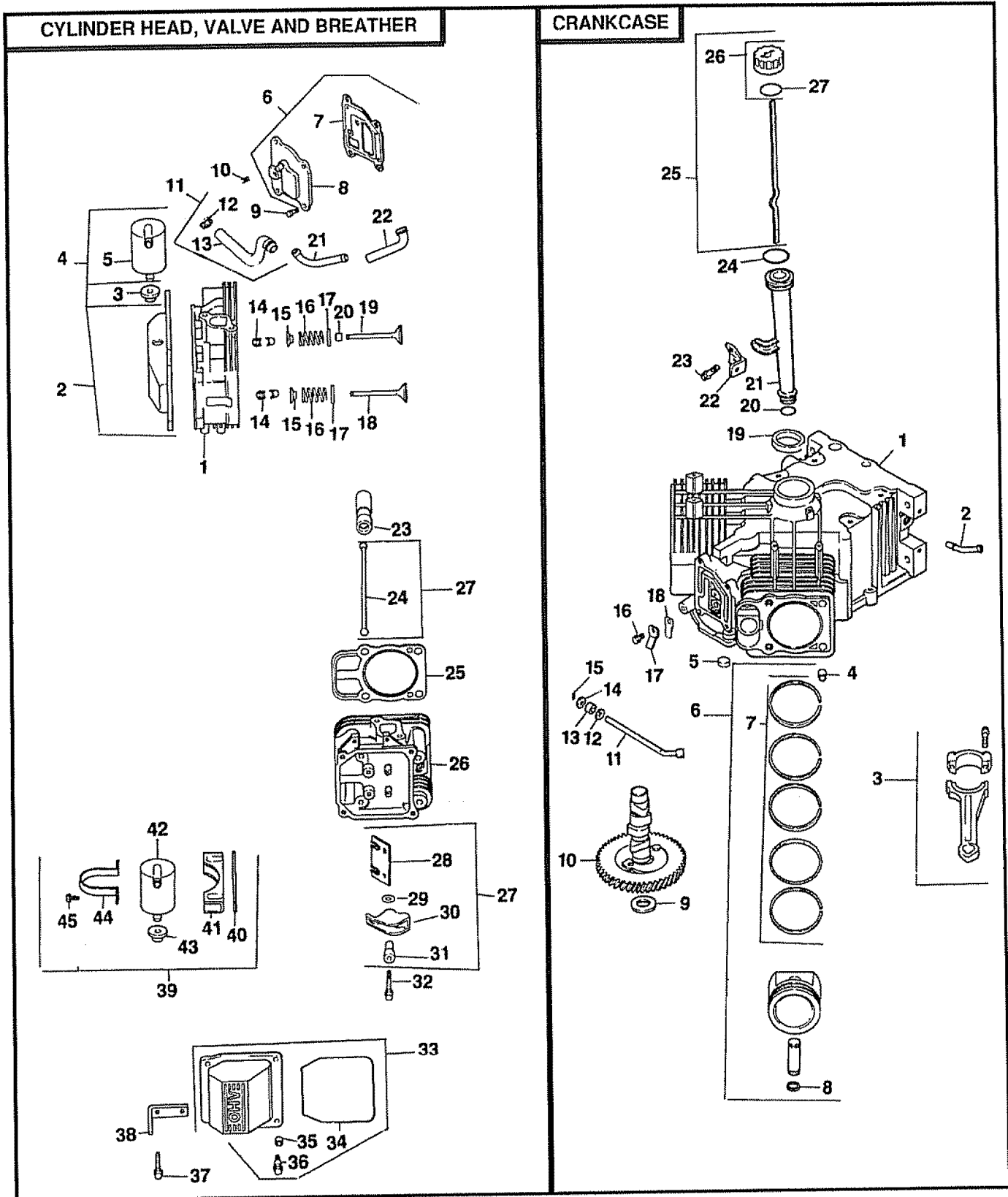

REPAIR PARTS

TRACTOR - - MODEL NUMBER 917.258911

KOHLER ENGINE - MODEL NUMBER CV22S, TYPE NUMBER 67515

CYLINDER HEAD/VALVE/BREATHER

KEY PART NO. NO.	DESCRIPTION
1 24-318-11	Head Assembly, #1 Cylinder
2 24-755-76	Kit, Valve Cover, Breather (Includes Key #3, 34 thru 36)
3 25-313-02	Grommet, Rubber
4 24-755-20	Kit, Breather (Includes Key #3 & 5)
5 24-595-02	Separator, Oil Breather
6 24-033-03	Kit, Breather Cover with Gasket (Includes Key Numbers 7 and 8)
7 24-041-23	Gasket, Breather
8 24-096-15	Cover, Breather
9 SM-0645020	Screw M6 x 1.0 x 20 (4)
10 X-75-23	Plug, Hex Head, Countersunk 1/8 N.P.T.F.
11 24-755-67	Kit, Breather Hose (Includes 12-13)
12 X-426-9	Clamp, Hose (2)
13 24-326-08	Hose, Breather
14 12-755-03	Kit, Retainer (4)
15 12-173-01	Cap, Valve Spring (4)
16 24-089-02	Spring, Valve (4)
17 235011	Retainer, Spring (4)
18 24-016-01	Valve, Exhaust, Standard Size (2)
24-016-02	Valve, Exhaust, .25 Oversize (2)
19 24-017-01	Valve, Intake, Standard Size (2)
24-017-02	Valve, Intake, .25 Oversize (2)
20 24-032-05	Seal, Valve Stem (2)
21 24-294-02	Fitting
22 24-326-05	Hose, Breather
23 12-351-01	Lifter, Valve (4)
24 24-411-04	Rod, Push (4)
25 24-041-08	Gasket, Cylinder Head (2)
26 24-318-12	Head Assembly, #2 Cylinder
27 24-755-61	Kit, Valve Train (Includes Key Numbers 24, 28-31)
28 24-146-09	Plate, Guide (2)
29 SM-0631005	Washer, Plain (4)
30 24-186-03	Arm, Rocker (4)
31 24-194-02	Pivot, Rocker Arm (4)
32 M-0640034	Screw M6 x 1.0 x 34 (4)
33 24-755-74	Kit, Valve Cover, Plain (Includes Key Numbers 34 thru 36)
34 24-153-11	O-Ring
35 24-112-08	Spacer (4)
36 24-086-32	Screw, Shoulder (4)
37 24-086-16	Screw M10 x 1.5 x 91 (8)
38 24-445-01	Strap, Lifting
39 24-755-57	Kit, Breather Separator (Includes Key Numbers 40 thru 45)
40 24-112-12	Spacer
41 24-126-44	Bracket, Breather Separator
42 24-595-02	Separator, Oil Breather
43 25-313-02	Grommet, Rubber
44 24-445-02	Strap, Breather Separator
45 M-0545016	Screw M5 x 0.8 x 16 (2)

CRANKCASE

KEY PART NO. NO.	DESCRIPTION
1 24-782-05	Cylinder Block (Use Miniblock)
2 24-294-03	Fitting
3 24-067-01	Connecting Rod (Standard) (2)
24-067-02	Connecting Rod (.25) (2)
4 12-380-03	Pin, Dowel Locating (6)
5 52-139-09	Plug, Cup
6 24-874-01	Piston with Ring Set (Standard) (2)
24-874-02	Piston with Ring Set (.25) (2)
24-874-03	Piston with Ring Set (.50) (2)
7 24-108-01	Ring Set (Standard) (2)
24-108-02	Ring Set (.25) (2)
24-108-03	Ring Set (.50) (2)
8 24-018-01	Retainer, Piston Pin (4)
9 12-422-10	Shim, Camshaft, Yellow
12-422-09	Shim, Camshaft, Green (As Required)
12-422-13	Shim, Camshaft, Black (As Required)
12-422-07	Shim, Camshaft, White (As Required)
12-422-08	Shim, Camshaft, Blue (As Required)
12-422-11	Shim, Camshaft, Red (As Required)
12-422-12	Shim, Camshaft, Grey (As Required)
10 24-010-03	Camshaft
11 24-144-01	Shaft, Governor Cross
12 X-25-63	Washer, Plain 1/4
13 12-032-01	Seal, Governor Cross Shaft
14 X-25-102	Washer, Plain 1/4
15 12-380-04	Pin, Hitch
16 M-0545010	Screw, Reed Retainer M5 x 0.8 x 10 (2)
17 24-018-04	Retainer, Reed (2)
18 24-402-05	Reed, Breather (2)
19 24-032-01	Seal, Oil, Front
20 12-153-01	O-Ring, Lower Oil Fill Tube
21 12-123-04	Tube, Oil Fill
22 24-126-19	Bracket, Oil Fill Tube
23 M-0545016	Screw, Oil Fill Tube Bracket M5 x 0.8 x 16
24 12-153-02	O-Ring, upper Oil Fill Tube
25 24-038-04	Dipstick Assembly (Includes 26-27)
26 25-755-13	Kit, Oil Fill Cap (Includes 27)
27 12-153-03	O-Ring, Dipstick

NOTE: All component dimensions given in U.S. inches
1 inch = 25.4 mm

REPAIR PARTS

TRACTOR - - MODEL NUMBER 917.258911

KOHLER ENGINE - MODEL NUMBER CV22S, TYPE NUMBER 67515

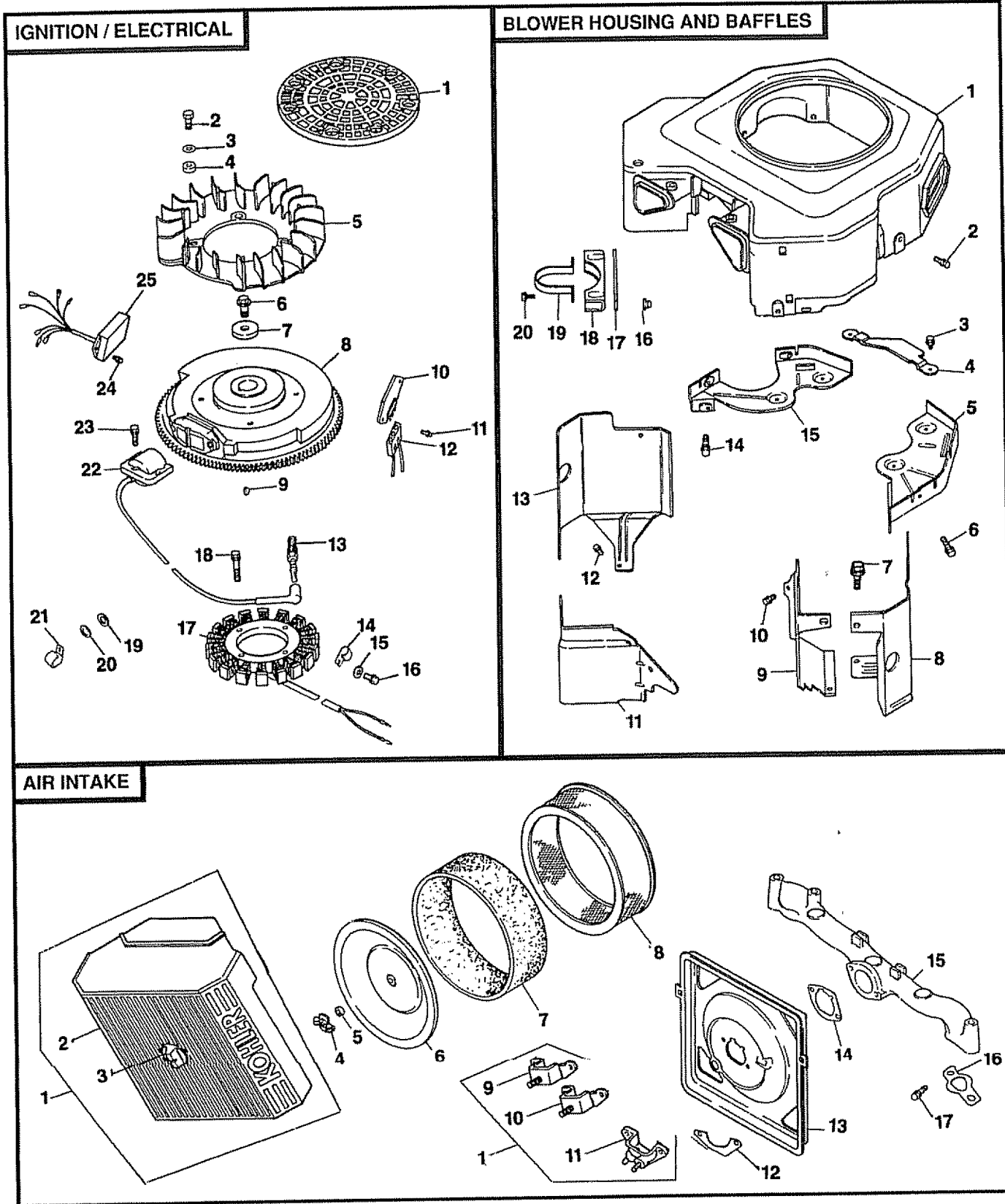

REPAIR PARTS

TRACTOR - - MODEL NUMBER 917.258911

KOHLER ENGINE - MODEL NUMBER CV22S, TYPE NUMBER 67515

IGNITION/ELECTRICAL

KEY PART NO. NO.	DESCRIPTION
1 24-162-17	Screen, Grass
2 M-0403025	Screw, Grass Screen M4 x 0.7 x 24 (4)
3 X-25-92	Washer, Plain 1/2 (4)
4 24-112-04	Spacer, Fan (4)
5 24-157-03	Fan
6 M-0639016	Screw M6 x 1.0 x 16 (4)
7 12-112-01	Spacer, Fan (4)
8 24-025-05	Flywheel Assembly
9 X-42-15	Key
10 25-403-03	Rectifier-Regulator
11 24-086-18	Screw, Phillips (2)
12 236602	Connector, Rectifier-Regulator, 3 Contact
13 12-132-02	Spark Plug (2)
14 48-154-02	Clip, Cable
15 12-468-03	Washer, Stator Harness Clip
16 12-086-14	Screw, Stator Harness Clip M10 x 1.5 x 46
17 24-085-01	Stator, 15 Amp
18 M-0548025	Screw, Stator Mounting M5 x 0.8 x 25 (2)
19 X-25-63	Washer, Plain 1/4 (2)
20 X-25-92	Washer, Plain 1/2 (2)
21 47-154-01	Clip, Cable
22 24-584-03	Module, Ignition (2)
23 M-0560020	Screw, Module M5 x 0.8 x 20 (4)
24 M-0448010	Screw, Module M4 x 0.7 x 10 (2)
25 24-584-05	Module, Speed Advance
NOT ILLUSTRATED	
-- 24-176-27	Harness, Wire
-- 24-518-04	Lead, Green (3", 18 Gauge, Insulated Grip Barrel Eyelets)
-- 24-113-18	Decal, Grass Screen
-- 24-063-27	Baffle, Heat Shield

BLOWER HOUSING & BAFFLES

KEY PART NO. NO.	DESCRIPTION
1 24-027-20	Housing, Blower
2 M-0549016	Screw M5 x 0.8 x 16 (3)
3 SM-0645016	Screw M6 x 1.0 x 16 (4)
4 24-314-05	Guard, Flywheel
5 24-146-02	Plate, Backing, # 2 Side
6 M-0545020	Screw M5 x 0.8 x 20 (2)
7 M-0551016	Screw M5 x 0.8 x 14
8 24-063-20	Baffle, Cylinder Barrel, # 2 Side
9 24-063-23	Baffle, Valley, # 1 Side
10 M-0545010	Screw M5 x 0.8 x 10 (2)
11 24-063-14	Baffle, Valley, # 2 Side
12 M-0545016	Screw M5 x 0.8 x 16 (2)
13 24-063-19	Baffle, Cylinder Barrel, # 1 Side
14 M-0645016	Screw M6 x 1.0 x 16 (2)
15 24-146-08	Plate, Backing, # 1 Side
16 24-100-01	Nut, Plastic
17 24-112-12	Spacer
18 24-126-44	Bracket, Breather Separator
19 24-445-02	Strap, Breather
20 24-086-27	Screw (2)
NOT ILLUSTRATED	
-- 24-100-01	Nut, Plastic (3) (Included with Blower Housing)
-- 24-100-02	Nut, Plastic (2) (Included with Blower Housing)
-- 25-139-16	Plug, Button 9/16 (Included with Blower Housing)
-- 24-113-23	Decal, Horsepower

AIR INTAKE

KEY PART NO. NO.	DESCRIPTION
1 24-743-05	Kit, Air Cleaner Cover (Includes Key Numbers 2, 3, and 9 thru 11)
2 24-096-24	Cover, Air Cleaner
3 25-341-02	Knob, Cover
4 12-100-01	Wing Nut
5 24-380-03	Pin, Latch Lever (2)
6 24-096-01	Cover, Inner Air Cleaner
7 24-083-02	Element, Pre-Cleaner
8 47-083-03	Element, Air Cleaner
9 24-126-21	Bracket, Air Cleaner
10 24-126-43	Bracket, Air Cleaner
11 24-109-01	Cup, Fuel Spitback
12 24-041-13	Gasket, Fuel Spitback Cup
13 24-094-02	Base, Air Cleaner
14 24-041-14	Gasket, Air Cleaner Base
15 24-164-06	Manifold, Intake
16 24-041-01	Gasket, Intake Manifold (2)
17 M-0639055	Screw M6 x 1.0 x 18 (4)
NOT ILLUSTRATED	
-- 12-113-53	Decal, Air Cleaner

NOTE: All component dimensions given in U.S. inches
1 inch = 25.4 mm

REPAIR PARTS

TRACTOR - - MODEL NUMBER 917.258911

KOHLER ENGINE - MODEL NUMBER CV22S, TYPE NUMBER 67515

STARTING SYSTEM

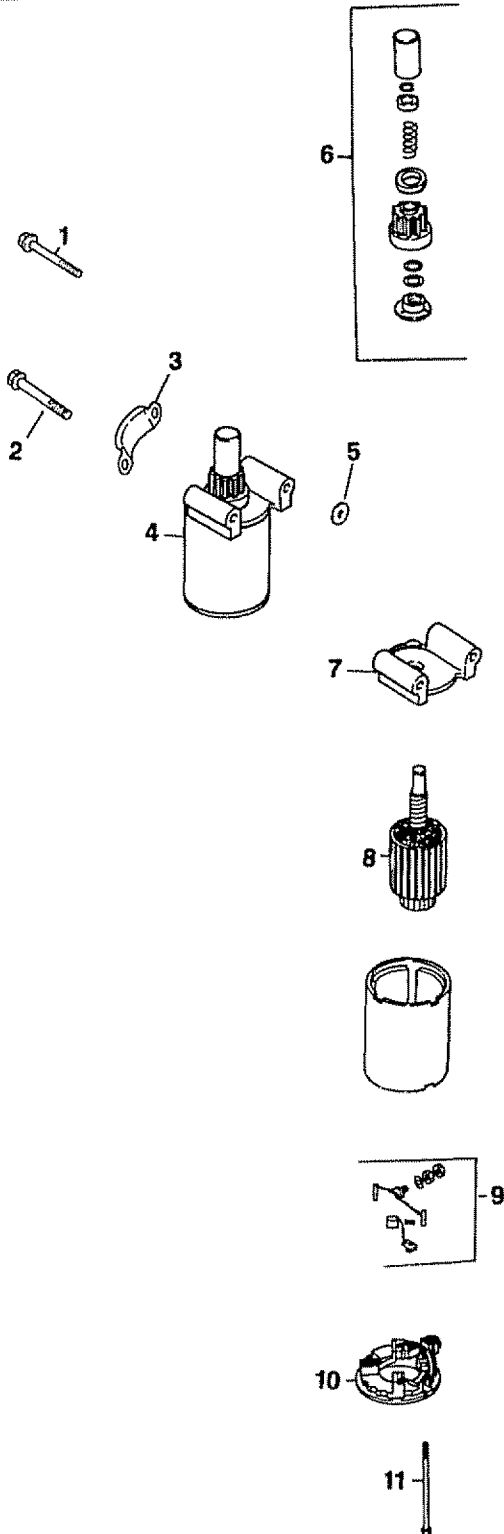

ENGINE CONTROLS

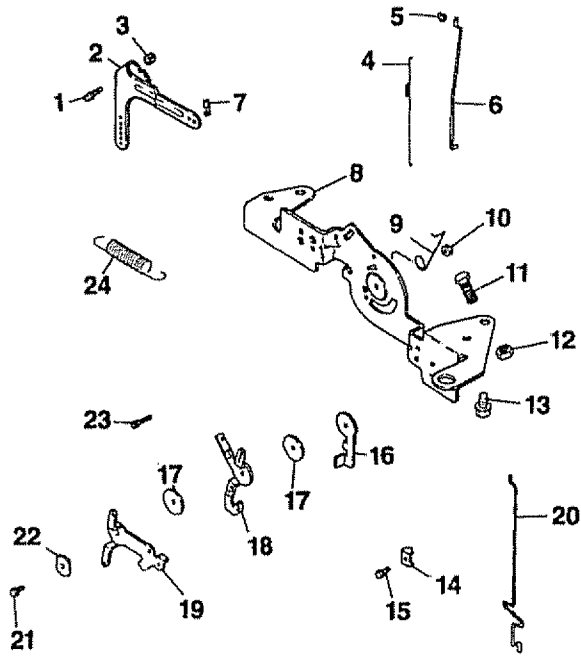

OIL PAN / LUBRICATION

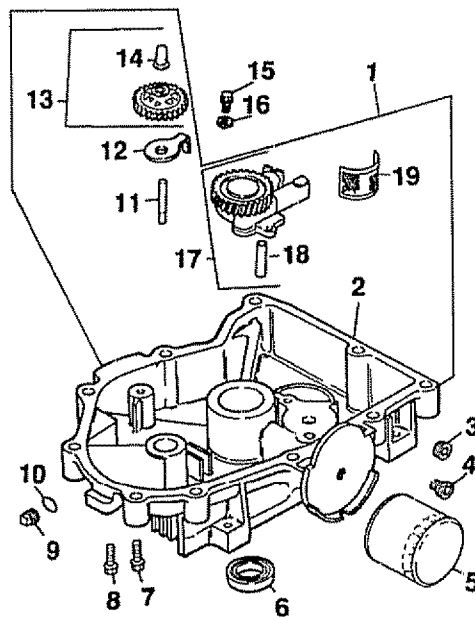

REPAIR PARTS

TRACTOR - - MODEL NUMBER 917.258911

KOHLER ENGINE - MODEL NUMBER CV22S, TYPE NUMBER 67515

STARTING SYSTEM

KEY PART NO. NO.	DESCRIPTION
1 M-0839070	Screw M8 x 1.25 x 70
2 M-0839080	Screw M8 x 1.25 x 80
3 24-096-05	Cover, Pinion
4 25-098-03	Starter Assembly (Includes 6-11)
5 12-468-01	Washer (3)
6 12-755-54	Kit, Drive End
7 12-227-06	Cap, Drive End
8 45-170-03	Armature
9 82-755-28	Kit, Brush and Spring
10 12-227-11	Cap, Commutator End
11 12-086-25	Bolt, Thru (2)

OIL PAN/LUBRICATION

KEY PART NO. NO.	DESCRIPTION
1 24-199-07	Oil Pan Assembly
2 24-199-04	Oil Pan
3 X-75-32	Plug, Hex, Countersunk, 3/8 N.P.T.F.
4 24-136-01	Nipple, Oil Filter
5 12-050-01	Filter, Oil
6 52-032-08	Seal, Oil (PTO End)
7 24-086-17	Screw, Oil Pan M8 x 1.25 x 45
8 24-086-16	Screw, Oil Pan M8 x 1.25 x 45 (9)
9 X-75-10	Plug, Solid, Square Head, 3/8 N.P.T.F.
10 24-153-08	O-Ring
11 12-144-02	Shaft, Governor Gear
12 52-448-02	Tab, Locking
13 24-043-12	Kit, Governor Gear with Pin (Includes Key Number 14)
14 12-380-01	Pin, Governor Regulating
15 M-0645025	Screw M6 x 1.0 x 25 (2)
16 SM-0631005	Washer, Plain (2)
17 24-393-08	Oil Pump Assembly (Includes 18)
18 24-123-05	Tube, Oil Pickup
19 25-162-07	Screen, Oil

ENGINE CONTROLS

KEY PART NO. NO.	DESCRIPTION
1 SM-0642025	Screw M6 x 1.0 x 25
2 24-090-14	Lever, Governor
3 SM-0641060	Nut M6 x 1.0
4 24-089-01	Spring, Linkage
5 25-158-08	Bushing, Linkage Retaining
6 24-079-04	Linkage, Throttle
7 25-158-11	Bushing, Throttle Linkage
8 24-126-13	Bracket, Control
9 24-089-03	Spring, Choke Return
10 M-0547050	Locknut, Hex M5 x 0.8
11 SM-0545016	Screw M5 x 0.8 x 16
12 M-0446030	Nut, Hex M4 x 0.7
13 SM-0645016	Screw M6 x 1.0 x 16 (4)
14 12-237-01	Clamp, Cable (2)
15 SM-0545016	Screw M5 x 0.8 x 16 (2)
16 24-090-07	Lever, Throttle Actuator
17 24-468-01	Washer (3)
18 24-090-13	Lever, Throttle Control
19 24-090-05	Lever, Choke
20 24-079-05	Linkage, Choke
21 SM-0545020	Screw M5 x 0.8 x 20
22 41-468-03	Washer, Wave
23 M-0403025	Screw M4 x 0.7 x 24
24 24-089-18	Spring, Governor

NOTE: All component dimensions given in U.S. inches
1 inch = 25.4 mm

REPAIR PARTS

TRACTOR - - MODEL NUMBER 917.258911

KOHLER ENGINE - MODEL NUMBER CV22S, TYPE NUMBER 67515

CRANKSHAFT

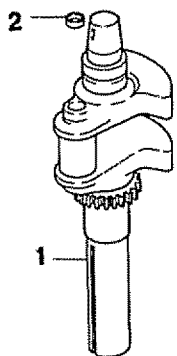

EXHAUST

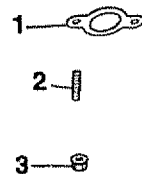

FUEL SYSTEM

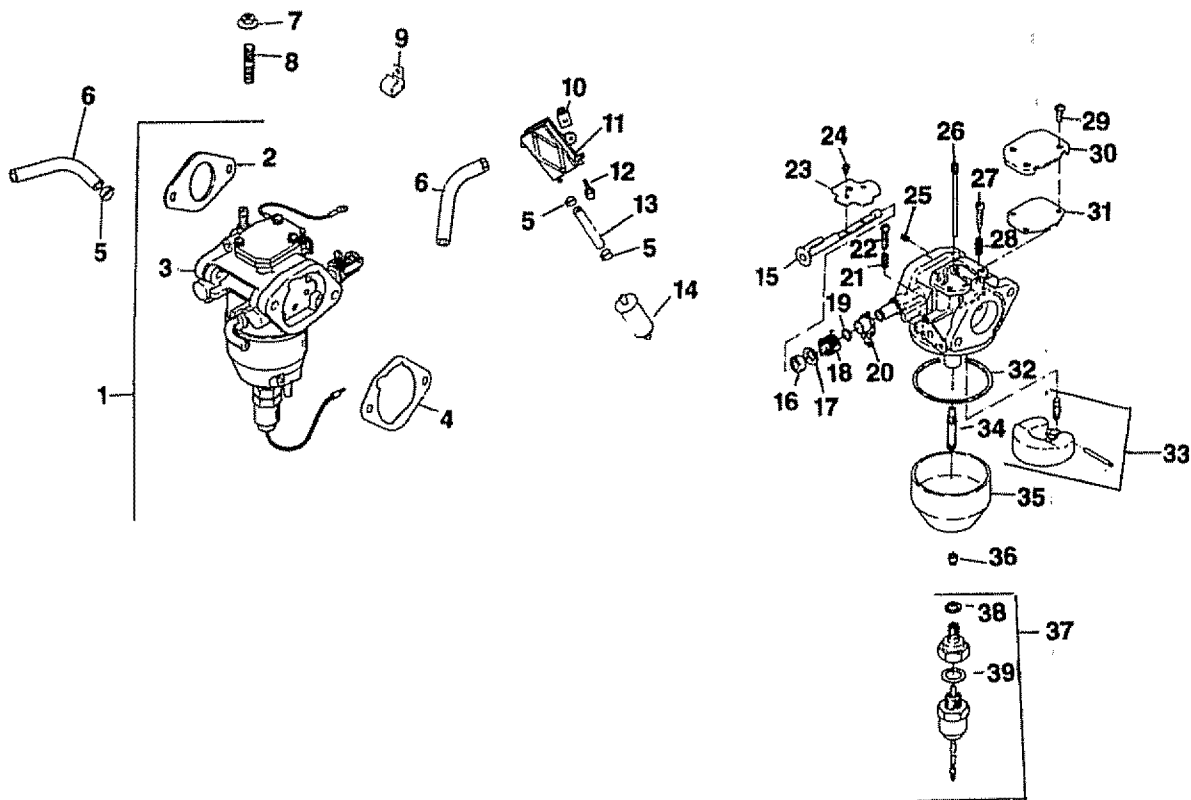

REPAIR PARTS

TRACTOR - - MODEL NUMBER 917.258911

KOHLER ENGINE - MODEL NUMBER CV22S, TYPE NUMBER 67515

FUEL SYSTEM

KEY PART NO.	NO.	DESCRIPTION
1	24-853-25	Kit, Carburetor with Gasket (Includes Key Numbers 2 thru 4)
2	24-041-15	Gasket, Carburetor
3	24-053-25	Carburetor Assembly (For Information Only, Not Available Separately) (Includes 15-39)
4	24-041-14	Gasket, Air Cleaner Base
5	X-426-9	Clamp, Hose (6)
6	24-353-03	Line, Fuel, 10-5/8" (2)
7	SM-0641060	Nut M6 x 1.0 (2)
8	M-0629095	Stud M6 x 1.0 x 95 (2)
9	47-154-01	Clip, Cable
10	24-100-01	Nut, Plastic (2)
11	24-393-04	Pump, Fuel, Pulse
12	24-086-12	Screw, Hex Cap Head (2)
13	25-353-03	Line, Fuel, 13-1/2"
14	25-050-02	Filter, Fuel
15	24-144-15	Shaft, Choke
16	24-468-05	Washer
17	24-241-01	Collar, Choke
18	24-089-22	Spring, Choke Return
19	24-141-04	Ring, Choke Lever
20	24-090-10	Lever, Choke
21	24-089-24	Spring, Throttle Adjust Screw
22	24-086-19	Screw, Throttle Adjust
23	24-462-02	Valve, Choke
24	24-086-20	Screw, Throttle and Choke Shaft (4)
25	24-337-27	Jet, Air Bleed
26	24-337-11	Jet, Slow
27	24-086-22	Screw, Idle Adjust
28	24-089-23	Spring, Idle Adjust Screw
29	24-086-21	Screw (3)
30	24-096-13	Cover, Passage
31	24-041-18	Gasket, Passage Cover
32	24-041-19	Gasket, Float Chamber
33	24-757-05	Kit, Float Repair
34	24-369-01	Nozzle, Main
35	24-234-01	Chamber, Float
36	24-337-28	Jet, Main
37	24-755-15	Kit, Solenoid Valve (Includes 38-39)
38	24-041-21	Gasket, Chamber Screw
39		Gasket, Solenoid

NOT ILLUSTRATED

--	24-041-15	Gasket, Carburetor
--	24-757-06	Kit, Carburetor Repair
--	24-755-72	Kit, High Altitude (1500-3000 Meters)
--	24-755-73	Kit, High Altitude (Over 3000 Meters)

CRANKSHAFT

KEY PART NO.	NO.	DESCRIPTION
1	24-014-72	Crankshaft
2	52-139-09	Plug, Cup

EXHAUST

KEY PART NO.	NO.	DESCRIPTION
1	24-041-02	Gasket, Exhaust (2)
2	M-0829033	Stud, Exhaust Manifold M8 x 1.25 x 20 (4)
3	M-0841080	Nut, Muffler Mounting M8 x 1.25 (4)

NOT ILLUSTRATED

KEY PART NO.	NO.	DESCRIPTION
--	24-755-03	Gasket Set

RPM Settings: Low Speed: 1150-1650
High Speed: 3200-3400

NOTE: All component dimensions given in U.S. inches
1 inch = 25.4 mm

SUGGESTED GUIDE FOR SIGHTING SLOPES FOR SAFE OPERATION

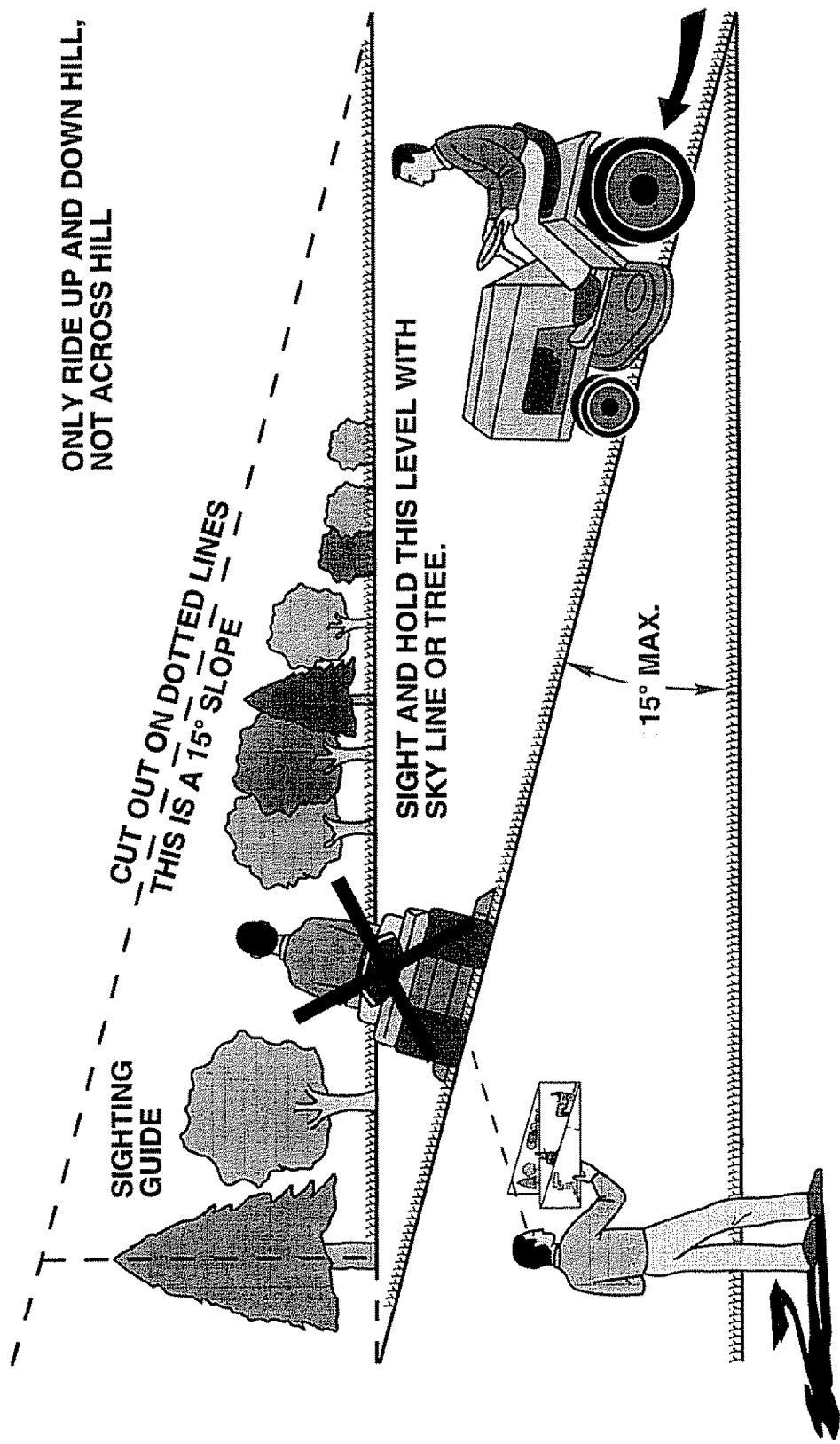

 Operate your Tractor up and down the face of slopes (not greater than 15°), never across the face. Make turns gradually to prevent tipping or loss of control. Exercise extreme caution when changing direction on slopes.

SEARS
OWNER'S
MANUAL

MODEL NO.
917.258911

IF YOU NEED
REPAIR SERVICE
OR PARTS:

FOR REPAIR SERVICE, CALL
THIS TOLL FREE NUMBER:

1-800-4-REPAIR
(1-800-473-7247)

FOR REPLACEMENT PARTS
INFORMATION AND
ORDERING, CALL THIS
TOLL FREE NUMBER:

1-800-FON-PART
(1-800-366-7278)

FOR CONSUMER ASSISTANCE
HOT LINE, CALL THIS
TOLL FREE NUMBER:

1-800-659-5917

CRAFTSMAN®

22.5 HP TWIN CYLINDER
ELECTRIC START
50" MOWER
HYDROSTATIC (AUTOMATIC)
GARDEN TRACTOR

Each tractor has its own model number. Each engine has its own model number.

The model number for your tractor will be found on the model plate located under the seat.

The model number for your engine will be found on the blower housing of the engine.

All parts listed herein may be ordered from any Sears, Roebuck and Co. Service Center/Department and most Retail Stores.

WHEN ORDERING REPAIR PARTS, ALWAYS GIVE THE
FOLLOWING INFORMATION:

- **PRODUCT - TRACTOR**
- **MODEL NUMBER - 917.258911**
- **ENGINE MODEL NO. - CV22-PS67515**
- **PART NUMBER**
- **PART DESCRIPTION**

Your Sears merchandise has added value when you consider Sears has service units nationwide staffed with Sears trained technicians... professional technicians specifically trained to insure that we meet our pledge to you, we service what we sell.