

Owner's / Operator's

Manual

READ THIS MANUAL CAREFULLY
IT CONTAINS IMPORTANT SAFETY INFORMATION

3170

169cc Fun Kart



RECOMMENDED MINIMUM OPERATOR AGE: 13

**THIS VEHICLE IS FOR OFF-ROAD USE ONLY
THIS VEHICLE IS NOT DESIGNED FOR USE ON RENTAL TRACKS OR RACING**

BEFORE OPERATING THIS VEHICLE, THE OWNER AND EACH OPERATOR MUST UNDERSTAND THIS VEHICLE WAS NOT DESIGNED OR MANUFACTURED TO MEET SPECIFICATIONS FOR USE ON PUBLIC ROADS, STREETS, HIGHWAYS, AND THOROUGHFARES. THE OWNER AND EACH OPERATOR MUST READ AND UNDERSTAND ALL THE INSTRUCTIONS FOR PROPER ASSEMBLY AND SAFE OPERATION, AS WELL AS THE INSTRUCTIONS CONCERNING THE ENGINE AND ALL OTHER PORTIONS OF THE VEHICLE. CHILDREN MUST BE OF AGE 13 OR OLDER AND SUPERVISED BY AN ADULT AT ALL TIMES WHEN USING THIS FUN-KART. THIS PRODUCT IS NOT A TOY.

MY VEHICLE IDENTIFICATION NUMBER

Record the VIN number and Model number of your ASW Fun Kart below for service and insurance records.

The VIN number can be found on the crossbar, behind the seat.

VIN: _____

Model: 3170B-____

AMERICAN SPORTWORKS LIMITED WARRANTY

American SportWorks (hereinafter referred to as "ASW") hereby warrants to the original purchaser that the frame components of new ASW recreational vehicles will be free from defects in material and workmanship. The period of warranty is thirty (30) days from date of purchase for the component parts (except as noted below), and ninety (90) days from the date of purchase for the frame. ASW, if notified of a defect in material or workmanship during the period of warranty, will repair or replace, at its option, defective parts at no charge, other than the reasonable cost for the transportation of the component(s). ASW will also agree to pay reasonable charges for labor, if necessary, to perform a warranty repair. Proof of Purchase must be provided to an approved ASW service center before any warranty work is performed.

The original purchaser must operate the vehicle and maintain the vehicle in accordance with the instructions provided in the Operator's Manual, the supplements hereto, and labels affixed to the vehicle. Additionally, within the (10) days of the discovery of an alleged defect, the original purchaser must provide written notification to: ASW's Customer Service Department at 4404 Engle Ridge Drive, Fort Wayne, IN 46804

The repair or replacement of any part or parts under this Limited Warranty shall not extend the term of the warranty beyond the original term as set forth above.

General Exclusions: This limited warranty does not cover component failure or damage caused by any of the following: abnormal strain or stress, neglect; abuse; improper assembly of components which were supplied in the factory sealed carton after the vehicle left ASW; improper maintenance, improper use of the vehicle, including, but not limited to racing, jumping, stunt driving, or any other uses prohibited by the Operator's Manual. Additionally, this warranty does not cover component failure or damage to vehicles which are leased or rented, or vehicles which are used at a concession track.

Specific Exclusions: This limited warranty does not apply to components, which are subject to normal wear and tear. These items include, but are not limited to, the tires, brakes, throttle, shift, and brake cables, drive belt, the torque converter system, chain, seat, lights, fasteners, decals, or cosmetic body panels and natural discoloration of material due to ultraviolet light. Downtime, pick-up and delivery charges are not covered by this warranty. This warranty does not apply to the engine, which is covered by its manufacturers warranty.

ASW MAKES NO OTHER WARRANTY OF ANY KIND, EXPRESSED OR IMPLIED. ALL WARRANTIES OF MERCHANTABILITY AND FITNESS FOR A PARTICULAR PURPOSE WHICH EXCEED THE OBLIGATIONS AND TIME LIMITATIONS SPECIFIED IN THE WARRANTY ABOVE ARE HEREBY DISCLAIMED BY ASW AND EXCLUDED FROM THIS WARRANTY. ADDITIONALLY, THIS WARRANTY EXCLUDES ANY INCIDENTAL OR CONSEQUENTIAL DAMAGES, INCLUDING BUT NOT LIMITED TO LOSS OF USE. SOME STATES DO NOT ALLOW A MANUFACTURER TO EXCLUDE OR LIMIT INCIDENTAL OR CONSEQUENTIAL DAMAGES AND, THEREFORE, THE ABOVE EXCLUSION MAY NOT APPLY TO YOU.

SOME STATES DO NOT ALLOW LIMITATIONS ON HOW LONG AN IMPLIED WARRANTY WILL LAST, IT IS POSSIBLE THAT THE ABOVE LIMITATION MAY NOT APPLY TO YOU. THIS WARRANTY GIVES YOU SPECIFIC LEGAL RIGHTS, AND YOU MAY ALSO HAVE OTHER LEGAL RIGHTS, WHICH VARY, FROM STATE TO STATE.

TABLE OF CONTENTS

AMERICAN SPORTWORKS LIMITED WARRANTY	1
FORWARD	3
CAUTIONS AND WARNINGS	3
IMPORTANT SAFETY INFORMATION	4
SOME WORDS ABOUT SAFETY	9
SAFETY LABELS	10
QUALIFICATIONS FOR FUN-KART USERS.....	11
Consumer Responsibility for Safe Use and Maintenance of a Fun-Kart.....	11
ARE YOU READY TO DRIVE?.....	13
Protective Apparel.....	13
Helmet and Eye Protection.....	13
Additional Driving Gear.....	13
Driver Training.....	13
No Alcohol or Drugs.....	14
IS YOUR VEHICLE READY TO DRIVE?.....	14
Pre-Ride Inspection.....	14
ENGINE STOPPED CHECKLIST	15
ENGINE STARTED CHECKLIST	16
SAFE DRIVING PRECAUTIONS.....	16
KART OPERATION	18
A. Operation controls.....	18
B. Throttle.....	18
C. Brake.....	18
D. Engine Starting.....	18
E. Engine Stop Switch.....	19
F. Seat Adjustment.....	19
G. Occupant Restraints	19
H. Rear Spoiler.....	19
KART FEATURES AND LOCATIONS	20
SERVICE INSTRUCTIONS	21
A. Air Cleaner	21
B. Engine Lubrication.....	21
C. Spark Plug.....	22
D. Carburetor Adjustment.....	22
E. Cleaning Instructions	22
F. General Lubrication	22
G. Chain Lubrication and Adjustment.....	22
H. Belt Replacement	23
I. Storage Instruction	23
GENERAL MAINTENANCE	24
A. Front Wheel Replacement	24
B. Rear Wheel Replacement	24
C. Front Wheel Alignment	24
D. Optional Speed Reduction Installation.....	24
REPLACEMENT PARTS AND SERVICE	25
Periodic Checks & Services	25
SPECIFICATIONS	26

FORWARD



Congratulations on the purchase of your ASW Fun Kart. Before operating this vehicle, the owner and each operator must understand that this vehicle was not designed or manufactured to meet specifications for use on public roads, streets, highways and thoroughfares. The owner, operator(s) and passenger(s) must read and understand all the instructions for proper assembly and safe operation, as well as the instructions concerning the engine and all other portions of the vehicle as described and illustrated in this manual and on the included safety DVD. Children must be of the specified age or older and supervised by an adult at all times when using the Fun Kart.

Be sure to follow the recommended maintenance schedule and service your kart accordingly. Preventative maintenance is extremely important to the longevity of your kart. **NOTE: A new kart requires an engine break in period of 5 hours, whereby the engine oil MUST be changed (See Engine Lubrication section page 21)**

Beginners are urged to seek instruction from a dealer or qualified instructor before and during the initial use of this kart. It is also recommended to practice in a large open area to become familiar with the operation of the kart.

We hope you will have a fun, safe experience with our products and thank you again for choosing an ASW Fun Machine.

CAUTIONS AND WARNINGS

-  This is the safety alert symbol. When you see this symbol on your machine or in this manual, be alert to the potential for personal injury.
-  Read and follow all instructions in this Owner's manual and any accompanying supplements before attempting to operate this Fun-Kart. Make sure to view the Operations and Safety video.

WARNING

Indicates a potential hazard that could result in severe personal injury or death

CAUTION

Indicates a potential hazard which may result in personal injury or damage to the Fun-Kart.

NOTE: Use of the word **"NOTE"** will alert you to key information or instructions.

IMPORTANT SAFETY INFORMATION

WARNING

Exhaust fumes are toxic.

- California Proposition 65 WARNING: Gasoline engine exhaust from this Fun-Kart contains chemicals known to the State of California to cause cancer, birth defects, or other reproductive harm. The engine exhaust contains carbon monoxide, which is a tasteless, odorless, poisonous gas.
- NEVER operate this Fun-Kart indoors or in an enclosed area without adequate ventilation

WARNING

This Fun-Kart may have been supplied to you completely assembled. To prevent injury or death read and follow the assembly instructions to make sure the Fun-Kart was assembled properly.

WARNING

Check tire pressure before each use.

- Prior to operating the vehicle check and adjust tire pressure to the proper operating pressure as indicated on the sidewall of each tire. A tire pressure gauge is required to obtain accurate readings.

WARNING

Fun-Kart modification or removal of original equipment or safety decals can render the Fun-Kart unsafe for operation.

WARNING

Safety decals must be replaced if they become unreadable or detached from the Fun-Kart.

- If decals are unreadable or missing, warning of potential hazards or safety requirements may be lacking.

WARNING

This Fun-Kart is not designed for use on rental tracks of any kind.

 **WARNING**

NEVER adjust, repair, or clean the Fun-kart while it is in motion.

 **WARNING**

The safe operation of this Fun-Kart is dependent upon the operator's ability to exercise proper judgment.

- Operator and passenger must not be too small or too large for controlled operation.
- Operator and passenger must be of sufficient age, understanding, mental capacity, and physical capacity to safely operate the Fun-Kart.
- Fun-Kart should only be operated after mature, supervised instruction and sufficient practice in an un-congested area.

 **WARNING**

Operator and any passengers **MUST** always wear a properly fitting motorcycle helmet approved by agencies such as the Department of Transportation (DOT), Safety Helmet Council of America (SHCA), or Snell Memorial Foundation (SNELL).

- Most accident fatalities are due to head injuries.
- Operator (and any passenger) should also wear face shields or goggles, boots, gloves and other appropriate protective clothing.

(See **KART OPERATION** on Page 19)

 **WARNING**

Long hair, loose clothes, or jewelry can get caught in moving parts below and behind the seat or surrounding environment.

- Remove or tie back anything loose that can reach below and behind the seat before riding.

 **WARNING**

NEVER place hands, feet, or any body parts or clothing near the engine, wheels, chain, and other rotating parts of the Fun-Kart while riding or running the engine.

- Use caution in performing required maintenance on or near operating engine.
- Use caution after the engine has been running, since the engine and other drive components may be extremely hot.

 **WARNING**

STOP the engine if the Fun-Kart makes unusual noises or vibrations.

- Check the Fun-Kart for damage.
- Excessive noise or vibration is a sign of loose or worn parts.

 **WARNING**

Keep guards in place at all times.

- Prevent accidental contact by the operator or service personnel while the Fun-Kart is running.
- The guards over the brake, clutch or torque converter, axle and drive sprockets also help prevent mud and debris from coming in contact with those items.

 **WARNING**

Be sure the passenger restraint system (i.e. Seat Belt) is properly adjusted and fastened at all times during operation.

- If the passenger restraint system is not properly used by the operator and/or passengers, loss of control and possible personal injury and/or Fun-Kart damage can occur.

 **WARNING**

When there is no passenger in the Fun-Kart, the passenger seatbelt must be securely fastened within the Fun-kart.

- If the passenger restraint system is not properly used by the operator and/or passenger, loss of control and possible personal injury and/or Fun-Kart damage can occur.

 **WARNING**

All screws, nuts, and bolts must be properly tightened to make sure the Fun-Kart is in safe operating condition.

 **WARNING**

Prevailing-torque type locknuts must be replaced with new after the old locknuts have been removed.

- Replace with the same type of locknut to make sure they function properly. Refer to the maintenance section for more information on locknuts.

 **WARNING**

Keep the engine free of dirt and debris, especially in the throttle linkage area.

 **WARNING**

NEVER start the engine without the operator properly seated and the restraint system properly adjusted and secured.

 **WARNING**

NEVER start the engine without checking to see that the throttle control is in idle position.

 **WARNING**

NEVER tamper with, alter, or change the Fun-Kart's engine governor settings.

- The governor as set by the engine manufacturer, limits maximum engine speed and protects the engine from damage.
- Excessive engine speed is potentially dangerous to operator, passengers, bystanders, and engine.

 **WARNING**

Check fuel supply before each use.

- NEVER fill fuel tank while the engine is running or hot.
- DO NOT overfill tank.
- ALWAYS allow at least ½" of expansion space at the top of tank.
- There should not be any fuel in the filler neck.
- Replace cap tightly to prevent a fuel spillage fire hazard.

NOTE: Always use an original gas cap or OEM replacement.

- NEVER fill fuel tank while the Fun-Kart is inside a building.
- After filling the tank, move the Fun-Kart at least ten feet before attempting to start the engine.

 **WARNING**

ALWAYS use extreme caution when starting the engine.

- Hot engine, muffler, or drive components can burn on contact.

 **WARNING**

Wet, slippery, rough, or sloped terrain is potentially dangerous and may result in injury if proper caution is not observed.

- ALWAYS SLOW DOWN
- Operator must use mature judgment, skill, and experience to choose a speed suitable for terrain and riding conditions in protecting operator, passenger, and/or any bystanders.
- Operator must use mature judgment, skill and experience in choosing suitable terrain for individual operational capabilities.

 **WARNING**

When turning on pavement, loose gravel, or similar surfaces, there is an increased risk in loss of control.

**** ALWAYS SLOW DOWN! ****

 **WARNING**

ALWAYS SLOW DOWN when turning.

- High-speed turning can cause loss of control and/or possible operator injury.
- Turning on a slope increases the risk of rollover.
- Practice operation is required to coordinate turning skill.
- Failure to operate this Fun-kart at a safe speed while turning can result in a strong possibility of severe personal injury.

 **WARNING**

Washing or operating the Fun-Kart in freezing temperatures can result in water freezing in the throttle cable conduit and/or on the throttle mechanism.

- This may result in the throttle sticking which can cause the engine to continue to run and result in loss of control.

 **WARNING**

Operating the Fun-Kart in conditions where water, mud, snow, dirt, sand, or other debris can get into the throttle cable conduit and/or on the throttle mechanism can cause binding of the cable and/or the throttle mechanism.

- This may result in the throttle sticking which can cause the engine to continue to run and result in loss of control.

 **WARNING**

Assembly, maintenance, and/or repair of this Fun-Kart should only be performed by designated dealers or authorized small engine centers (for engine repairs) so that no unsafe conditions or modifications are made.

 **WARNING**

Read and keep all supplied printed material.

- Supplements to this Operator's Manual contain updated information relative to your specific Fun-Kart model. It is important to keep all of these documents for reference.

 **WARNING**

When making repairs or adjustments to the Fun Kart, the spark plug wire MUST be disconnected and kept away from the spark plug to prevent accidental starting.

- When working on, around, or restarting the engine, use extreme caution to avoid contact with the muffler, cylinder head or any potentially hot area on or around the engine.
- Ensure that all guards are in place prior to starting the engine.

 **CAUTION**

During Fun-Kart storage, keep it in a place where gasoline fumes will not reach and open flame, spark, or other source of ignition.

- For long-term storage, fuel tank should be drained in an open, cool area.
- Engine must be allowed to cool before storage in any enclosure.
- NEVER store the Fun-kart in close proximity to appliances such as hot water heaters or furnaces.

 **WARNING**

NEVER operate the Fun-Kart while under the influence of alcohol, drugs, or medication of any kind.

- Such operation is dangerous to yourself and/or others.

 **CAUTION**

Brush Bars assembled to this Fun-Kart are for decorative purposes and limited brush protection.

- Brush Bars were not designed for roll over or to restrict all brush or tree branches from protruding into operator/passenger compartment.

 **CAUTION**

If the Fun-Kart should start making an unusual noise or vibrating abnormally, the engine should be stopped and the spark plug wire disconnected. The vehicle should then be checked for damage. Excessive noise or vibration is generally a warning of loose or worn parts.

SOME WORDS ABOUT SAFETY

The following pages present important information and recommendations to help you drive your Kart safely. Please read through these pages thoroughly and view the Kart Safety DVD that was included with your unit.

SAFETY LABELS

The following labels have been applied to your Fun Kart and should be considered as permanent parts of the vehicle. If a label should come off, become hard to read, or become damaged, contact your dealer or American SportWorks Customer Service department for warning label replacements.

WARNING



HOT SURFACES

Surfaces around the engine and exhaust can be extremely hot. Allow surfaces to cool before servicing.

11330-A

WARNING



ENTANGLEMENT HAZARD

Shoulder length and longer hair or loose clothing can get caught in moving parts behind or below the seat. **Restrain hair at or above shoulder level.** Restrained hair must not interfere with the proper fit of the helmet. **Securely restrain anything loose** that reaches behind or below the seat.

11330-B

WARNING



CHECK TIRE PRESSURES

Improper inflation of tires can cause **loss of control**, resulting in serious injury or death. Refer to Owner's Manual for proper operating pressure.

11330-D

WARNING



ALWAYS WEAR SEATBELT

Seatbelt must be properly fastened and adjusted for each occupant prior to operating the vehicle; See Owner's Manual.

11330-I

WARNING



Under 13 Age

This vehicle is not to be operated by anyone under **13 years of age**. A speed reduction kit is available for this vehicle.

11330-T

WARNING

GUARD MUST BE IN PLACE

This guard must be in place during engine operation. Keep hands, feet, and loose garments away from engine, chain, and drive components.

CAUTION

DO NOT PUT FOOT ON DRIVE COVER

11330-C

WARNING



PINCH HAZARD

Exercise caution when working on drive components. Drive chain turns when vehicle is in motion. **Chock wheels before removing drive cover.** Never remove drive cover or attempt to service with engine running.

11330-R

WARNING

OBSERVE THE FOLLOWING INSTRUCTIONS

Failure to understand and follow Warnings and instructions for the safe use and maintenance of this product may result in **Death or Injury!** This information is contained in the Warning Labels, Owner's Manual & Supplements, Safety Video, and Engine Manual supplied with this product. Make sure that you understand and follow all Warnings and Instructions in this material.

- Read owner/operator manuals carefully.
- Adult supervision required.
- Always wear a D.O.T.-approved motorcycle helmet, eye protection, and protective clothing.
- Do NOT operate the vehicle without the brush bars securely in place.
- Keep all covers and shields properly installed.
- Throttle, Stop Switch, and Brake Controls must work properly and freely before starting the engine.
- Operator must be seated, safety belt must be fastened, and brake applied before operating the vehicle.
- Not legal for street use. Use only on flat, level, off-road terrain.
- Not designed for racing or commercial use.
- Never operate at speeds too fast for your skills or the conditions.
- Never attempt jumps or other stunts.
- Never ride after consuming alcohol, drugs, or other intoxicants.

If you did not receive any of the material listed above, please call **1-800-643-7332** and request to have them sent to you at no charge.

11330-J

WARNING



NO RIDING

All occupants must be inside the vehicle and wearing the proper restraints and safety gear. **Absolutely no riding on the outside of the vehicle or on the cargo rack.**

11330-K

WARNING



EXHAUST GAS HARMFUL

Engine exhaust from this product contains chemicals, known in certain quantities to cause cancer, birth defects, or other reproductive harm.

11330-N

WARNING



LIGHT CARGO ONLY

This rack is intended for light cargo only, not exceeding 25 lbs. All cargo must be secured with proper tie-downs.

11330-P

WARNING



WEAR A HELMET

Always wear a D.O.T.-approved motorcycle helmet when operating this vehicle.

11329

CAUTION

USE ONLY MID-GRADE UNLEADED GASOLINE (89 - 93 OCTANE)

This engine is not designed for fuels other than automotive gasoline. Attempting to use anything other than this will cause damage to the engine.

11330-U

QUALIFICATIONS FOR FUN-KART USERS

This Fun-Kart is restricted to use by operator and passenger with a minimum age of thirteen years. Fun-Karts are intended for use by operators who meet the physical and cognitive capabilities set out by the manufacturer in the material provided with the Fun-Kart. A 20mph speed reduction kit is available for this fun kart.

Consumer Responsibility for Safe Use and Maintenance of a Fun-Kart

1. Fun-Karts shall not be modified from the manufacturer's original design and configuration.
2. Fun-Karts shall not be used to perform racing, stunt riding, jumps, spinouts, donuts, or other maneuvers as they may cause loss of control. As such, these activities are likely to result in possible injury to the operator, passenger, bystanders, or all.
3. Prior to each use, the operator shall perform the preoperational checks specified by the manufacturer, and further verify:
 - a. Smooth throttle operation and positive return of the throttle linkage to a closed throttle position when released;
 - b. That the throttle cable and linkages operate properly and the throttle cable or other linkages are adjusted properly;
 - c. That the steering linkage is adjusted and operates smoothly;
 - d. That the engine stop switch is properly functioning;
 - e. That all guards originally supplied by the manufacturer are in proper place in serviceable condition;
 - f. That engine idle speed is below the point of clutch or torque converter engagement;
 - g. That the gas tank is in good condition and the proper gas cap is fastened securely;
 - h. That the braking system is functioning properly;
 - i. That all safety labels are in place, legible and understood;
 - j. That any and all axle guards, chain guards, torque converter covers, or other covers or guards supplied by the manufacturer are in place and in serviceable condition;
 - k. That tires are in good condition, inflated properly, and have sufficient tread remaining; and
 - l. That all fasteners are in place and tightened securely.
4. Fun-Kart engines shall not be started unless the operator is seated in proper position for vehicle operations and the brake fully engaged and locked with park brake mechanism.
5. Long hair, loose clothes, or jewelry can get caught in moving parts below the seat or surrounding environment. Remove or tie back anything loose that can reach below or behind the seat before riding.
6. Fun-Karts shall only be fueled by a supervisor knowledgeable with regard to proper fueling techniques.
7. A supervisor shall verify personally that everyone operating or riding is knowledgeable, capable, and has the cognitive capacity to operate the Fun-kart safely, including those items specified in 1 through 6.
 - a. The supervisor shall only allow the use and operation of the Fun-Kart after demonstration that each operator can understand and operate all components of the Fun-Kart prior to use.
 - b. The supervisor shall provide continuous supervision during Fun-Kart use.
 - c. The supervisor shall not allow anyone to ride in or operate the Fun-Kart with long hair, loose clothes, or jewelry that can get caught in moving parts below the seat or surrounding environment. Remove or tie back anything loose that can reach below or behind the seat before riding.

8. Fun-Kart operators and passengers shall adhere to all manufacturer's recommendations and instructions, as well as comply with all laws and ordinances, and the following:
 - a. Operators shall stay seated with both hands on the steering wheel and both feet in the Fun-Kart at all times, whether moving or stationary, unless the Fun-Kart is stopped completely and the engine has been shut off.
 - b. Passengers shall remain seated with arms and legs inside the Fun-Kart at all times during Fun-Kart operation.
 - c. Shall observe minimum age restrictions.
 - d. Shall not ride the Fun-Kart if long hair, loose clothes, or jewelry reach below or behind the seat.

 **WARNING**

Long hair, loose clothes, or jewelry can get caught in moving parts below and behind the seat or surrounding environment. Remove or tie back anything loose that can reach below or behind the seat before riding.

- e. Shall not allow smoking in the Fun-Kart.
 - f. Persons under the influence of drugs, alcohol, or intoxicants shall not supervise, operate, or ride in a Fun-Kart.
 - g. Fun-Karts shall operate only on a surface or terrain recommended by the Fun-Kart's manufacturer.
 - h. Fun-Karts shall not be operated on roads, streets, highways, or any other location where road vehicles are intended to travel.
 - i. Fun-Karts shall be operated only with adequate lighting and under conditions of suitable visibility.
9. Persons with the following conditions shall not ride in or operate a Fun-Kart:
 - a. Those with heart conditions
 - b. Pregnant women
 - c. Persons with head, back, or neck ailments, or prior surgeries to those areas of the body.
 - d. Persons with any mental or physical conditions, which may make them susceptible to injury or impair their physical dexterity or mental capabilities to recognize, understand, and perform all of the safety instructions, and be able to assume the hazards inherent in Fun-Kart use.
 10. Fun-Kart shall not be used to:
 - a. Transport a passenger except in the seating area provided.
 - b. Transport materials or equipment.
 - c. Transport animals.
 11. Fun-kart operators always shall use appropriate protective clothing, including but not limited to a motorcycle helmet and eye protection, with appropriate certification, and any other equipment recommended by the Fun-Kart manufacturer including gloves, footwear, long sleeve shirts, and long pants.
 12. No operator or other person shall contact any portion of the engine, wheels, or drive train for any purpose including maintenance until the engine has been turned off and allowed to cool, and the Fun-Kart is in a stable and stationary position.
 13. Passenger restraints must be used in accordance with, and limited to, the manufacturer's guidelines.
 14. Fun-Kart components shall be maintained and repaired in accordance with the manufacturer's specifications and utilizing only the manufacturer's authorized replacement parts with installation performed by designated dealers or other skilled persons.

ARE YOU READY TO DRIVE?

Before each drive, you need to make sure that you and your kart are both ready to drive. To help get you prepared, this section discusses how to evaluate your driving readiness, what items you should check on your kart, and adjustments to make for your comfort, convenience, or safety. Before you drive your kart for the first time, we urge you to:

- Read this owner's manual and the labels on your kart carefully.
- Make sure you understand all the safety messages.
- Know how to operate all the controls.
- View and understand the included safety DVD

Protective Apparel

Although complete protection is not possible, wearing proper gear can reduce the chance of injury should you have an accident. The following suggestions will help you choose the proper protective gear.

Helmet and Eye Protection

Your helmet is your most important piece of protective gear because it offers the best protection against head injuries. A helmet should fit your head comfortably and securely.

Open-face helmets offer some protection, but a full-face helmet offers more. Regardless of the style, look for a D.O.T. (Department of Transportation) or Snell Memorial Foundation (SNELL) sticker on any helmet you buy. Always wear a face shield or goggles to protect your eyes and help your vision.

WARNING

Operating this kart without wearing an approved motorcycle helmet, eye protection, and protective clothing could increase your chances of head and/or eye injury, and the possibility of death in the event of a severe accident.

Always wear an approved motorcycle helmet that fits properly, eye protection (goggles or face shield), gloves, boots, long-sleeved shirt or jacket and long pants.

Additional Driving Gear

In addition to a helmet and eye protection, we also recommend:

- Sturdy off-road motorcycle boots to help protect feet, ankles, and lower legs.
- Off-Road motorcycle gloves to help protect your hands
- Driving pants with knee and hip pads, a driving jersey with padded elbows, and chest protection.

Driver Training

Developing your driving skills is an ongoing process. Even if you are an experienced driver, take time to become familiar with the kart controls and how the kart handles. Practice driving in a safe, open area to develop your skills. Do not drive on rough terrain until you get accustomed to the kart controls and feel comfortable with its size and weight.

 **WARNING**

Operating this kart without your seat belt could cause you to be thrown from the kart, causing serious injury or death.

No Alcohol or Drugs

Alcohol, drugs and karts don't mix. Even a small amount of alcohol can impair your ability to operate a kart safely. Likewise, drugs, even if prescribed by a physician, can be dangerous while operating a kart. Consult your doctor to be sure it is safe to operate a vehicle after taking medication.

 **WARNING**

Operating this kart after consuming alcohol or drugs can seriously affect your judgment, cause you to react more slowly, affect your balance and perception, and could result in serious injury or death. Never consume alcohol or drugs before or while operating this kart.

IS YOUR VEHICLE READY TO DRIVE?

Before each drive, it is important to inspect your kart and make sure any problems you find are corrected. A pre-drive inspection is a must, not only for safety, but because having a breakdown, or even a flat tire, can be a major inconvenience.

If your kart has overturned or has been involved in a collision, do not drive it until your kart has been inspected by your dealer. There may be damage or other problems that you cannot see.

 **WARNING**

Improperly maintaining this kart or failing to correct a problem before driving can cause an accident resulting in serious injury or death.

Always perform a pre-drive inspection before every drive and correct any problems.

Pre-Ride Inspection

The following checklist should be utilized to inspect your vehicle before each use to ensure that it is in proper working order.

ENGINE STOPPED CHECKLIST

	ITEM	INSPECTION PROCEDURE	ACTION
1.	Engine Oil Level	Add oil if required. Check for leaks. Tighten filler cap securely.	Refer to operator's manual.
2.	Fuel level	Add fuel if necessary. DO NOT overfill. DO NOT mix oil with gas. Replace cap tightly.	Refer to operator's manual. DO NOT refuel a hot engine. Allow engine to cool before adding fuel.
3.	Warning Decals	Make sure all warning decals are legible and securely attached.	Replace as necessary.
4.	Tires	Tread must have a minimum height of 1/8" at center of tire. Prior to operating vehicle, check and adjust tire pressure as indicated on the sidewall of each tire. A tire pressure gauge is required to obtain accurate readings.	Replace tires if tread height is less than 1/8" at center of tire. Add or remove air as necessary to meet requirements indicated on sidewall of each tire.
5.	Drive Train	Check condition and tension	Lubricate, adjust tension as necessary.
6.	Throttle	Check for smooth operation. Ensure throttle 'snaps' back to idle. Check for frayed or loose cable. Check for mud, debris, and ice in throttle mechanism	Replace damaged cable. Clean out any mud and debris. If ice is present, move Fun-kart to a warm place and allow the ice to melt and water to dry.
7.	Fasteners	Check wheels to see that all axle nuts are tightened securely. Check for missing fasteners. Check that all other fasteners are secure.	Tighten fasteners as necessary. Replace fasteners as necessary
8.	Brush Bars	Make sure all brush bars are in place and securely attached.	Replace damaged bars or fasteners and tighten as necessary.
9	Steering	Make sure steering turns freely Check for proper 'toe-in' of wheels.	Lubricate and adjust as necessary.
10.	Frame / Chassis	Check for bent or otherwise damaged frame and/or other chassis components.	Replace as necessary.
12.	Guards	Check all guards covering moving parts.	Tighten fasteners on loose guards. Replace worn or damaged guards.

ENGINE STARTED CHECKLIST

	ITEM	INSPECTION PROCEDURE	ACTION
1.	Stop Switch	Perform stop switch test.	Repair / replace as necessary.
2.	Throttle	Check idle adjustment.	Adjust as necessary.
3.	Brakes	Ensure brakes function properly.	Adjust / replace as necessary.

SAFE DRIVING PRECAUTIONS

Off-Road Use Only:

Your kart and its tires are designed and manufactured for off-road use only, not for use on paved surfaces. Driving on paved surfaces can affect the kart handling, control, and cause excessive wear to your tires.

WARNING

Operating this kart on paved surfaces may seriously affect handling and control of the kart, and may cause the vehicle to go out of control.

When driving off-road, also remember to always obey local off-road driving laws and regulations. Obtain permission to drive on private property. Avoid posted areas and obey "NO TRESPASSING" signs.

You should never drive your kart on public streets, roads or highways, even if they are not paved. Drivers of street vehicles may have difficulty seeing and avoiding you, which could lead to a collision.

WARNING

Operating this kart on public streets, roads or highways could result in a collision with another vehicle. Never operate this kart on any public streets, roads or highways, whether they are dirt, gravel or paved surfaces.

Keep Hands and Feet on Controls

When driving your kart, always keep both hands on the steering wheel and both feet on the foot controls. It is important to remain alert and remain focused when driving the kart. Removing hands or feet from the controls can reduce your ability to react and maintain control of the kart.

WARNING

Removing your hands from the steering wheel or feet from the foot controls during operation can reduce your ability to control the kart and could result in a collision. Always keep both hands on the steering wheel and both feet on the foot controls of your kart during operation.

Control Speed

Driving at excessive speeds increases the likelihood of an accident. In choosing an appropriate speed, you must consider the capability of your kart, the terrain, visibility and other operating conditions, in addition to the skill and experience of the driver.

 **WARNING**

Operating this kart at excessive speeds increases your chances of losing control of the kart, resulting in an accident. Always drive at a speed that is appropriate for your skill, your kart, the terrain, visibility and other operating conditions.

Use of this Kart on Unfamiliar or Rough Terrain

Before driving in an unfamiliar area, always check the terrain thoroughly. Don't drive fast on unfamiliar terrain or when visibility is limited (it is often difficult to react to hidden obstructions like rocks, bumps, or holes).

 **WARNING**

Failure to use extra care when operating this kart on unfamiliar terrain could result in the kart overturning or going out of control. Go slowly and use extreme caution when operating on unfamiliar terrain. Always be alert to changing terrain conditions when operating the kart.

Never drive past the limit of visibility. Maintain a safe distance between your kart and other off-road vehicles. Always exercise caution and use extreme care on rough, slippery and loose terrain.

 **WARNING**

Failure to use extra care when operating on excessively rough, slippery or loose terrain could cause loss of traction or vehicle control, resulting in an accident or overturn. Do not operate on excessively rough, slippery or loose terrain until you have learned and practiced the skills necessary to control the kart on such terrain. Always be especially cautious on these types of terrain.

Do Not Perform Stunts

You should always operate your kart in a safe and reasonable manner. When driving, always keep all four wheels on the ground.

 **WARNING**

Attempting wheelies, jumps, and other stunts increase the chances of an accident, including an overturn. Never attempt stunt riding of any type and ride responsibly. Don't try to show off.

KART OPERATION

A. Operation controls

WARNING

Do not attempt to start or operate the engine until completely familiar with the location and use of each control necessary to operate this vehicle. The operator must know how to stop this machine before starting and driving it.

B. Throttle

The right foot pedal is the throttle, controlling the speed of the kart. As the engine speed increases above idle, the clutch automatically engages and moves the vehicle forward. To disengage the clutch at any time, allow the throttle to return to the idle position. (See Fig Below)

WARNING

Every time, prior to starting the engine, check the throttle assembly to ensure that when the pedal is pushed all the way forward the assembly is working smoothly and returns to idle when released. Do not operate this unit if pedal or engine throttle linkage fail to return to the idle position. If unable to correct the problem through lubrication, adjustment or replacement of worn parts, contact your dealer for assistance.

C. Brake

The brake is controlled by the left foot pedal (See Figure below). Applying pressure to the pedal draws the brake pads against the brake disc at the wheels and slows or stops the kart. The locking lever can be applied to act as a park brake and should remain applied during starting and engine warming (choke cycle).

D. Engine Starting

Apply foot brake and ensure the Engine Stop Switch is in the RUN/ON position. Have a supervisor start the engine by opening the choke, located on the engine, then pulling the recoil starter. **NOTE: Your Fun-Kart is equipped with (2) engine stop switches, one located on the dash and one located on the engine electrical cover. BOTH switches must be in the "RUN/ON" position for the engine to start.**

The engine will warm up within 5 minutes, allowing the engine to operate at the normal RPM. The choke may be closed at this time. On a warm day, this period of time may be reduced to less than 1 minute.

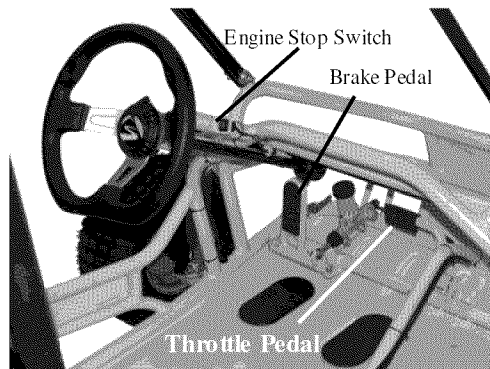

CAUTION

This unit has been shipped with special **BREAK-IN** oil pre-filled in the engine crankcase. This oil **MUST** be changed after 5 hours of operation. Replace with a 10W30 weight motor oil as described in the **SERVICE** section of this manual.

E. Engine Stop Switch

Before driving this vehicle, test the Engine Stop Switch to ensure that it is operating properly. With the engine running, switch the Engine Stop Switch to the STOP/OFF position to shut down the engine.

F. Seat Adjustment

The unit is equipped with an adjustable seat. To adjust, lift the lever just in front of the seat bottom (between the drivers legs) and move the seat either forward or backward. Release the lever at the desired seat location, ensuring that the lever snaps back into place to lock the seat.

 **WARNING**

Never operate this kart when the seat is not securely locked into position. Serious injury or death could occur due to loss of control. Always make seat adjustments with the kart fully stopped and the engine shut off.

G. Occupant Restraints

This kart is equipped with 3 point retracting seat belts. Insert the metal tongue into the buckle until it is securely attached. Final adjustments should be made with the plastic tension stop such that the belt is against the shoulder and chest with no excess slack.

H. Rear Spoiler

The spoiler is NOT to be used as a cargo rack. Do not place items on, or tie items to the spoiler.

 **WARNING**

Attempting to use the spoiler as a cargo rack may cause serious injury or death. Do not place items on, or tie items to the spoiler.

KART FEATURES AND LOCATIONS

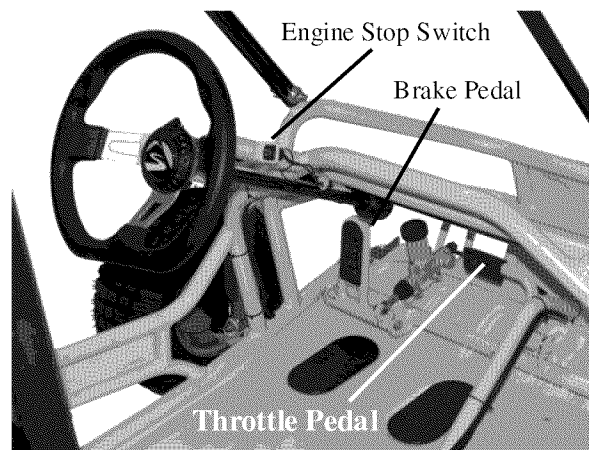

SERVICE INSTRUCTIONS

A. Air Cleaner

This unit is equipped with a foam-style air filter element and should be replaced after every 20 hours of operation.

NOTE: Operation in unusually dusty conditions may require more frequent replacement.

- 1) Remove the air cleaner cover by releasing the tab.
- 2) Clean any excess dirt, oil, or dust from the air cleaner box with a mild detergent and water solution.
- 3) Thoroughly dry the air box
- 4) Replace the air cleaner element
- 5) Replace the cleaner cover.

CLEANER COVER

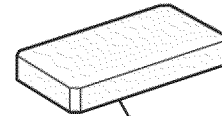
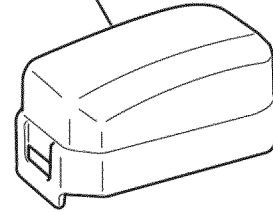

URETHANE FOAM

B. Engine Lubrication

You **MUST** change the oil in the crankcase after the first 5 hours of operating a new engine. The engine oil should then be changed every 10 hours of use thereafter. This will ensure proper lubrication of the internal parts and prevent costly repairs due to excessive wear.

CAUTION

This unit has been shipped with special **BREAK-IN** oil pre-filled in the engine crankcase. This oil **MUST** be changed after 5 hours of operation. Replace with SAE 10W30 weight motor oil as described in the *following section*.

WARNING



Used oil **MUST** be disposed of at a proper collection center

- 1) Remove the drain plug located on the bottom of the right rear side of the engine. Elevating the front of the kart slightly will help drain all of the oil.
- 2) The oil should be emptied into a suitable container for recycling.

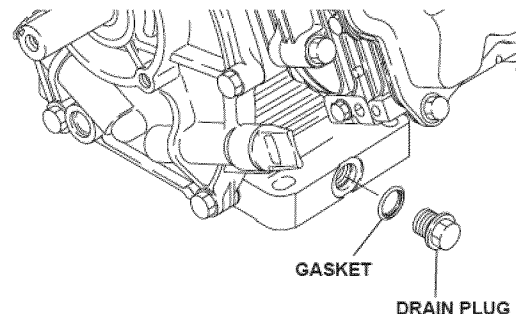
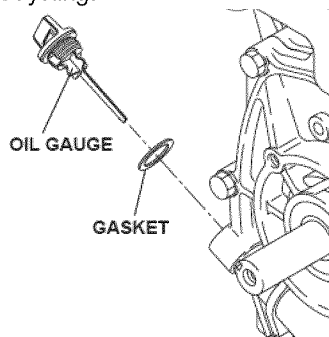

- 3) With the oil completely drained, replace the drain plug and tighten securely.
- 4) Place the kart back onto a flat surface to level the engine, and Re-fill the crankcase with 20oz of SAE 10W30 motor oil.
- 5) Check the oil level using the dipstick attached to the oil fill cap. Be sure to check the oil level before each use of the

kart. Add oil when necessary to keep the oil level between the bottom of the dipstick and the "O" mark. **NOTE: Oil level should be checked by dipping the oil level stick into the crankcase WITHOUT screwing the cap in.**

C. Spark Plug

- 1) Remove and inspect the spark plug each time you change the oil. The electrodes should be kept clean and free of carbon. The presence of carbon (dark matter) or excess oil (wet) will greatly reduce engine performance. If possible, check the spark plug gap (area between the electrodes) using a wire feeler gage or spark plug gap tool.
- 2) **Correct gap is 0.6 - .07mm.**
- 3) Before installing the spark plug, coat the threads lightly with graphite lubricant to ensure easier removal of the plug in the future.
- 4) Spark plug should be replaced once a year for optimum engine performance.

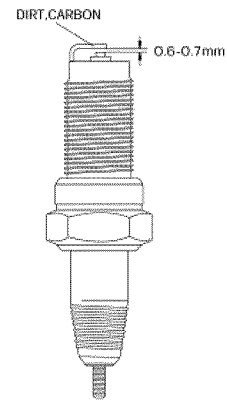

D. Carburetor Adjustment

All the necessary carburetor adjustments have been made at the factory, and the recommended settings are correct for most applications. To adjust the engine idle setting on the carburetor:

- 1) Allow the engine to warm up for 5-10 minutes.
- 2) Using a Phillips screwdriver, adjust the idle screw (shown) until the engine settles at approximately 1400RPM.

NOTE: For further carburetor adjustments, refer to the Engine Service Manual available online from Robin Subaru at www.robinamerica.com.

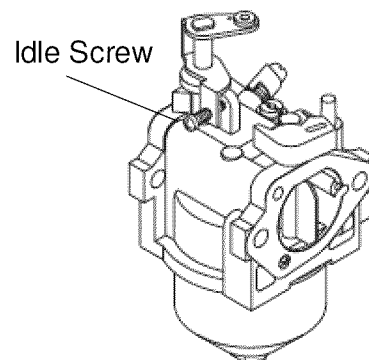

E. Cleaning Instructions

Keep your kart clean by using a clean rag and a mild detergent and water solution. Wipe off all dirt and oil from around the controls. Wipe off any spilled fuel and oil. Keep the engine clean and clear of foreign objects, especially those around the air intake fan and air inlet ductwork.

F. General Lubrication

Lubricate the vehicle at least every 90 days, and more often, if the kart is used daily or in unusually dusty conditions.

G. Chain Lubrication and Adjustment

For optimum chain life, lubrication with a spray on chain lubricant should be performed on a regular basis. **DO NOT USE OTHER OILS.**

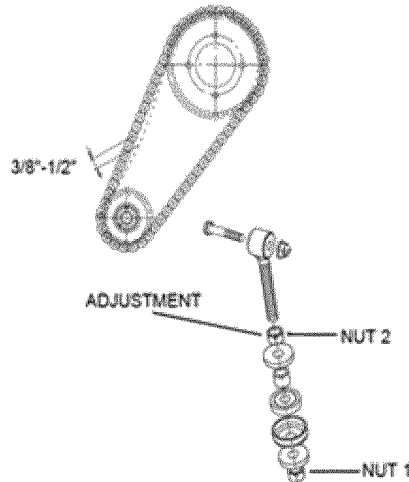
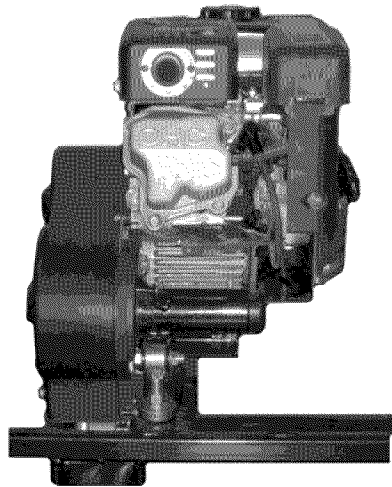

A new chain will stretch within the first few hours of use and therefore will require adjustment. The first chain adjustment should be made after the first 2 hours of use. If the chain has more than $\frac{1}{2}$ " of slack or "flex" then it will require adjustment. To adjust:

- 1) Loosen Nut (1).
- 2) Adjust nut (2) until the proper chain tension is achieved.
- 3) Re-tighten Nut (1).

H. Belt Replacement

Ensure the kart is on a smooth flat surface and the engine is OFF. Apply parking brake. Remove the three mounting bolts for the belt cover. Remove mounting screw located behind the belt cover at the bottom. Using a $\frac{1}{2}$ " socket or box wrench, remove the drive (front) pulley mounting bolt and pull the pulley off the crank shaft. If the existing belt is still in tact, remove existing belt. If not, look for anything that may have caused the belt to fail prematurely. Inspect and clean pulley with dry cloth or compressed air. Install new belt with the tapered edge away from the engine. Place belt around the driven (rear) pulley and stretch over the crank shaft and onto the spanner. Replace the drive pulley and mounting bolt. Tighten bolt to 30 ftlb.

I. Storage Instruction

If you plan to store (and not operate) your kart for a period in excess of 30 days, or at the end of each driving season, the unit should be set up for storage as follows:

- 1) Drain fuel tank and carburetor by allowing the engine to run until the fuel system is dry.
- 2) Lubricate the engine cylinder by removing the air cleaner and by spraying an engine fogging oil through the carburetor.
- 3) Do NOT save or store gasoline over the winter. Using old gasoline, which will deteriorate from storage, will make the engine difficult to start and affect the performance of the engine.
- 4) To protect the paint, plastics and upholstery, it is a good idea to keep the unit covered when not in use.

GENERAL MAINTENANCE

A. Front Wheel Replacement

Remove cotter pin and castle nut. Wheel should be easily removed. After replacing the wheels, tighten castle nut and replace cotter pin with a new one. Replace rubber cover.

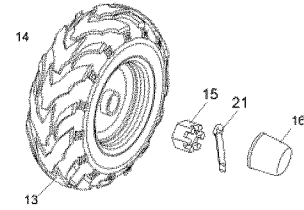

B. Rear Wheel Replacement

Remove cotter pin, castle nut, and washer. Wheel should be easily removed. After replacing the wheels, replace the washer, tighten castle nut and replace cotter pin with a new one. Replace rubber cover.

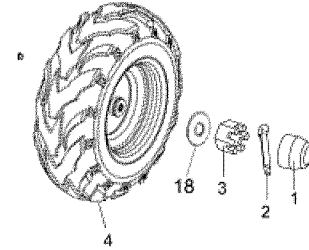

C. Front Wheel Alignment

The front wheels should be set with a “toe-in” from 1/4” to 1/2”. At the centerline of the tires, measure the Distance A and the Distance B. For proper toe adjustment, Dimension A should be 1/4” – 1/2” greater than Dimension B. While adjusting, ensure rubber boots are in good condition.

To make adjustments:

- 1) Loosen the lock nuts on both sides of Front Tie Rods.
- 2) Ensure the steering wheel is centered, and adjust Dimension B by equally rotating the tie rods in or out with a 12mm wrench.
- 3) After adjusting to the desired length, tighten the lock nuts against the Tie Rods.
- 4) Recheck the dimensions for proper alignment.

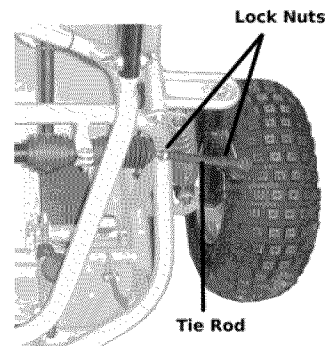
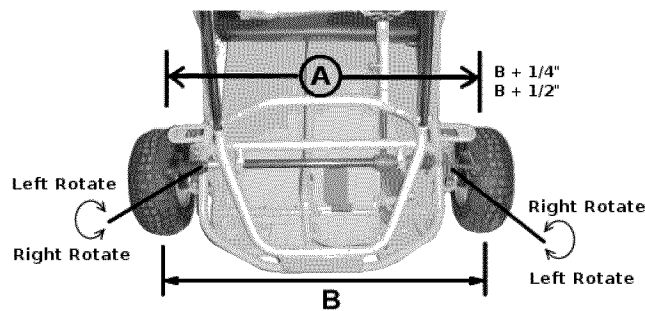

Toe Adjustment Diagram

D. Optional Speed Reduction Installation

This kart has been equipped with provision for a speed reduction kit to reduce the overall speed of the unit to 20mph max. This kit is available from your dealer or directly from American SportWorks by calling customer service at 1-800-643-7332. Or visit our website at www.amsportworks.com.

REPLACEMENT PARTS AND SERVICE

Most replacement parts are typically available from your dealer. Because of immediate availability and convenience, it is recommended that replacement parts be ordered from an authorized dealer. Take this manual and all supplements to the dealer when ordering parts in person.

If replacement parts are not available from a dealer, they may be ordered directly from American SportWorks at 1-800-643-7332 or online at www.amsportworks.com. Orders may be subject to a minimum fee. A listing of authorized service center locations in your area is also available from our Customer Service department.

Record the vehicle VIN number in the spaces provided at the front of this manual. The VIN number can be found on the crossbar, behind the seat.

Periodic Checks & Services

The maintenance intervals in the following table are based upon average driving conditions. Driving in unusually dusty areas may require more frequent servicing.

Item	Initial Service (First Week)	Monthly	Quarterly	Yearly
Tire Pressure / Wear	I	Inspect Daily		
Brake System	I	I		
Fastener Tightness	I	I		
Air Cleaner		R		
Carburetor	I			C
Spark Plug			C, A	R
Brake Fluid	I	I		
Engine Oil	R (5hr)	R (every 10hr)		
Chassis		C, I	L	
Fuel Filter		I		R
Drive Chain Tension	I, A (2 hours)	I, A		

A = Adjust, C= Clean, I = Inspect, L= Lubricate, R= Replace

SPECIFICATIONS

Dimensions

Overall Length -----	71.0 in. (1803mm)
Overall Width-----	47.0 in. (1194mm)
Overall Height-----	49.0 in. (1244mm)
Wheelbase-----	51.0 in. (1295mm)
Front Track (C/L of Tire)-----	41.5 in. (1054mm)
Rear Track (C/L of Tire)-----	35.0 in. (889mm)
Ground Clearance -----	6.0 in. (152mm)

Engine

Type-----	Single Cylinder Oil & Air cooled 4-Stroke
Engine Capacity -----	169cc
Bore / Stroke-----	67.0mm x 48.0mm
Displacement -----	169.0 cm ³
Corrected Compression Ratio-----	8.5:1
Carburetor -----	Z6Y4
Maximum Horsepower-----	5.7 hp @ 4000rpm
Maximum Torque-----	8.3 ft-lbs @ 2500rpm
Starting -----	Pull-Recoil
Ignition -----	Induction
Lubrication -----	Splash SAE-10W/30
Transmission-----	CVT automatic
Spark Plug-----	BR-6HS (NGK)
Plug Gap -----	0.6-0.7mm
Fuel Type-----	ONLY USE Mid-Grade Unleaded (89 - 93 Octane)

Capacities

Maximum Load (Driver & Passenger)-----	300lbs
Fuel Tank -----	0.95 Gal
Engine Oil -----	20 Oz
Climbing Angle -----	20° - 25°
Battery -----	None
Fuse -----	None
Top Speed (20mph Speed Reduction Kit Available) -----	22 - 24mph

Miscellaneous

Brakes (Rear)-----	Hydraulic Disc
Front Tire -----	145/70 - 6 @ 10psi
Rear Tire -----	16 x 8.0 - 7 @ 10psi
Front Suspension -----	Independent Dual A-Arm
Rear Suspension -----	Swing Arm/Double Oil Damped Shock
Restraint System-----	3-Point Retractor Style Belt
Final Drive Chain-----	#420 - 5/8" Pitch
Net Weight -----	300 lbs