

INSTALLATION INSTRUCTIONS

R-410A Ducted Horizontal Air Conditioner

Product Family: HC4A3

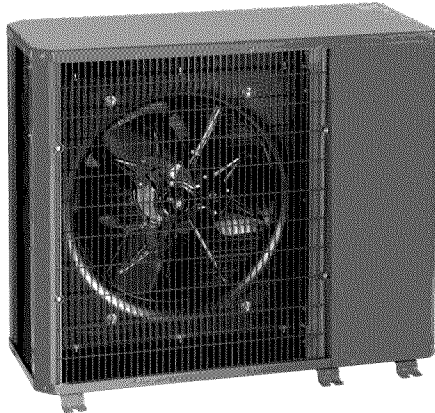

Fig. 1 – HC4A3

NOTE: Read the entire instruction manual before starting the installation.

TABLE OF CONTENTS

	PAGE
SAFETY CONSIDERATIONS	1
INSTALLATION	2 – 9
Step 1 – Complete Pre-Installation Checks	2
Step 2 – Rig and Mount Unit	2
Step 3 – Complete Refrigerant Piping Connections ..	5
Step 4 – Make Electrical Connections	8
START-UP	11
SERVICE	11
MAINTENANCE	15
TROUBLESHOOTING	15

SAFETY CONSIDERATIONS

Improper installation, adjustment, alteration, service, maintenance, or use can cause explosion, fire, electrical shock, or other conditions which may cause death, personal injury, or property damage. Consult a qualified installer, service agency, or your distributor or branch for information or assistance. The qualified installer or agency must use factory-authorized kits or accessories when modifying this product. Refer to the individual instructions packaged with the kits or accessories when installing.

Follow all safety codes. Wear safety glasses, protective clothing, and work gloves. Use quenching cloth for brazing operations. Have fire extinguisher available. Read these instructions thoroughly and follow all warnings or cautions included in literature and attached to the unit. Consult local building codes and National Electrical Code (NEC) for special requirements.

Recognize safety information. This is the safety-alert

symbol  When you see this symbol on the unit and in instructions or manuals, be alert to the potential for personal injury. Understand these signal words; DANGER, WARNING, and CAUTION. These words are used with the safety-alert symbol. DANGER identifies the most serious hazards which **will** result in severe personal injury or death. WARNING signifies hazards which **could** result in personal injury or death. CAUTION is used to identify unsafe practices which **would** result in minor personal injury or product and property damage. NOTE is used to highlight suggestions which **will** result in enhanced installation, reliability, or operation.



WARNING

ELECTRICAL SHOCK HAZARD

Failure to follow this warning could result in personal injury or death.

Before installing, modifying, or servicing system, main electrical disconnect switch must be in the OFF position. There may be more than 1 disconnect switch. Lock out and tag switch with a suitable warning label.

INSTALLATION

WARNING

UNIT OPERATION AND SAFETY HAZARD

Failure to follow this warning could result in personal injury or equipment damage.

R-410A refrigerant systems operate at higher pressures than standard R-22 systems. Do not use R-22 service equipment or components on R-410A refrigerant equipment.

CAUTION

PERSONAL INJURY AND EQUIPMENT DAMAGE HAZARD

Failure to follow this caution may result in personal injury and / or equipment damage.

DO NOT operate the unit without a filter or with grille removed.

Step 1 —Complete Pre-Installation Checks

Unpack Unit

Move the unit to final location. Remove unit from carton, being careful not to damage service valves and grilles.

Inspect Shipment

File a claim with the shipping company if shipment is damaged or incomplete. Check the unit nameplates to ensure units match job requirements.

Consider System Requirements

Consult local building codes and NEC for special installation requirements.

Allow sufficient space for airflow clearance, wiring, refrigerant piping, and servicing unit. See Fig. 2.

Locate unit so that condenser airflow is unrestricted on both sides. Refer to Fig. 2.

Unit may be mounted on a level pad directly on base legs or mounted on raised pads at support points. See Fig. 2 for center of gravity.

Matching the Condensing Unit to an Indoor Unit

The HC4A318-60 ducted condensing units can be matched to corresponding indoor units. The HC4A3 unit can be matched with under-ceiling and residential fan coils and evaporator coils. Refer to separate indoor unit literature for more information.

Step 2 —RIG AND MOUNT UNIT

Mounting on Ground

Mount unit on a solid, level concrete pad. Position unit so water or ice from roof does not fall directly onto unit. Accessory stacking kits can be used when units are to be stacked. See installation instructions provided with the accessory kit. Use field-provided snow stand or ice rack where prolonged subfreezing temperatures or heavy snow occurs.

If conditions or local codes require unit be fastened to a pad, 6 field-supplied tiedown bolts should be used and fastened through slots provided in unit mounting feet.

Mounting on Roof

Mount unit on a level platform or frame at least 6 in. (152.4 mm) above roof surface. Isolate unit and tubing from structure.

Fig. 2 – HCA43 Unit Dimensions

UNIT	SERIES	ELECTRICAL CHARACTERISTICS					A	B	C	D	E	F	G	H	J	K	L	M	N	P	OPERATING WEIGHT(lbs)	SHIPPING WEIGHT(lbs)	SHIPPING DIMENSIONS (L x W x H)
HC4A318**A	1	X	O	O	O	25 1/8"	36 15/16"	14 9/16"	16"	23 7/16"	17 3/16"	17 1/8"	22"	13"	6 5/8"	11 1/4"	5/8"	2 15/16"	6"	155	171	42 9/10" X 18" X 28 1/10"	
HC4A324**A	1,2	X	O	O	O	31 1/8"	36 15/16"	14 9/16"	16"	23 7/16"	17 3/16"	23 1/8"	28"	14"	6 3/4"	11 5/8"	5/8"	2 15/16"	6"	180	198	42 9/10" X 18" X 34 1/10"	
HC4A330**A	1	X	O	O	O	37 3/16"	44 9/16"	17 1/16"	18 7/16"	30 1/2"	19 5/8"	29 3/16"	34 1/16"	13 11/16"	8 1/8"	15 7/8"	3/4"	3 7/16"	6 1/2"	200	223	50 1/2" X 20 1/2" X 40 2/10"	
HC4A336**A	1	X	O	X	X	37 3/16"	44 9/16"	17 1/16"	18 7/16"	30 1/2"	19 5/8"	29 3/16"	34 1/16"	13 11/16"	8 1/8"	15 7/8"	3/4"	3 7/16"	6 1/2"	218	240	50 1/2" X 20 1/2" X 40 2/10"	
HC4A348**A	1,2	X	O	X	X	43 3/16"	44 9/16"	17 1/16"	18 7/16"	30 1/2"	19 5/8"	35 3/16"	40 1/16"	14 1/2"	8 1/2"	18 7/8"	7/8"	3 7/16"	6 1/2"	284	309	50 1/2" X 20 1/2" X 46 2/10"	
HC4A360**A	1,2	X	O	X	X	43 3/16"	44 9/16"	17 1/16"	18 7/16"	30 1/2"	19 5/8"	35 3/16"	40 1/16"	14 1/2"	8 1/2"	18 7/8"	7/8"	3 7/16"	6 1/2"	294	319	50 1/2" X 20 1/2" X 46 2/10"	

208-230-1-60
230-1-60
208/230-3-60
460-3-60

X = YES
O = NO

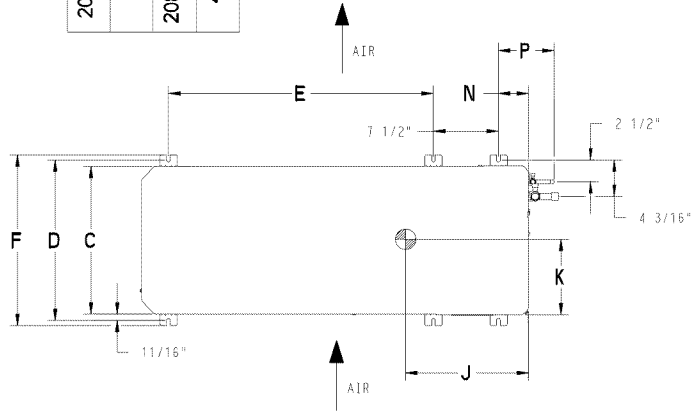

1. REQUIRED CLEARANCES: WITH COIL FACING WALL; ALLOW 6" MIN CLEARANCE ON COIL SIDE AND COIL END AND 36" MIN CLEARANCE ON COMPRESSOR END AND FAN SIDE. WITH FAN FACING WALL; ALLOW 8" MIN CLEARANCE ON FAN SIDE AND COIL END AND 36" MIN CLEARANCE ON COMPRESSOR END AND COIL SIDE. WITH MULTI UNIT APPLICATION; ARRANGE UNITS SO DISCHARGE OF ONE DOES NOT ENTER INLET OF ANOTHER.
2. MINIMUM OUTDOOR OPERATING AMBIENT IN COOLING MODE IS 55°F, MAX. 125°F.
3. SERIES DESIGNATION IS THE 10TH POSITION OF THE UNIT MODEL NUMBER.
4. CENTER OF GRAVITY
5. ALL DIMENSIONS ARE IN "INCHES" UNLESS NOTED.

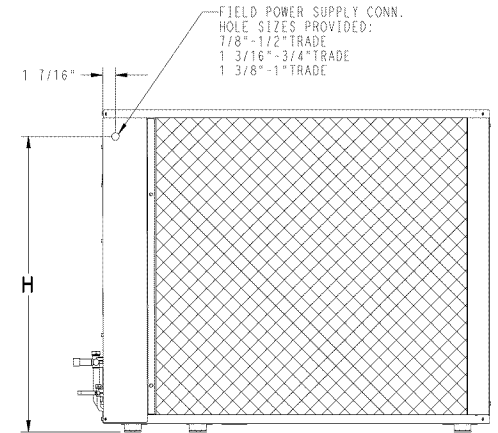
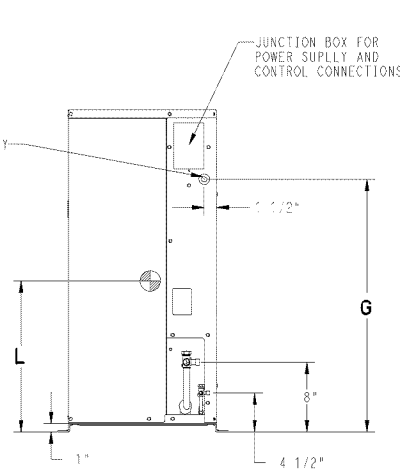
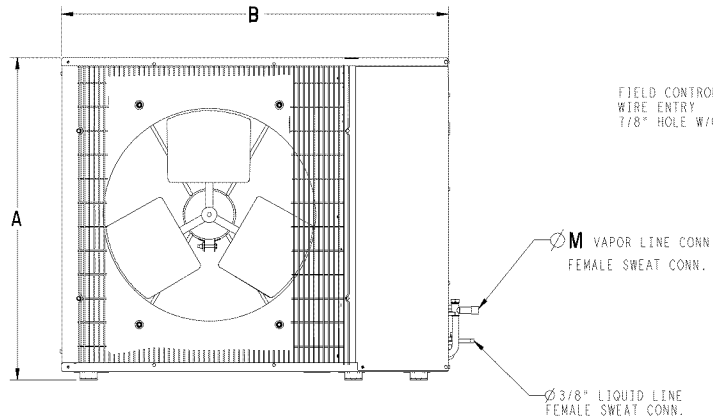

UNIT SIZE	MINIMUM MOUNTING PAD DIMENSIONS
18,24	23" X 42"
30,36,48,60	24" X 50"

MEASUREMENT- ENGLISH
SD4834-4-B

UNIT	SERIES	ELECTRICAL CHARACTERISTICS					A	B	C	D	E	F	G	H	J	K	L	M	N	P	OPERATING WEIGHT(KG)	SHIPPING WEIGHT(KG)	SHIPPING DIMENSIONS (L x W x H)
HC4A318**A	1	X	0	0	0	638.2	938.2	369.9	406.4	595.3	436.6	435.0	588.8	330.2	168.3	285.8	15.9	74.6	152.4	70.4	77.7	1090.2 X 457.7 X 714.3	
HC4A324**A	1,2	X	0	0	0	790.6	938.2	369.9	406.4	595.3	436.6	587.4	711.2	355.6	171.5	295.3	15.9	74.6	152.4	81.8	90.0	1090.2 X 457.7 X 866.7	
HC4A330**A	1	X	0	0	0	944.6	1131.9	433.4	468.3	774.7	498.5	741.4	865.2	347.7	206.4	403.2	19.0	87.3	165.1	90.9	101.4	1282.7 X 520.7 X 1020.7	
HC4A336**A	1	X	0	X	X	944.6	1131.9	433.4	468.3	774.7	498.5	741.4	865.2	347.7	206.4	403.2	19.0	87.3	165.1	99.0	109.0	1282.7 X 520.7 X 1020.7	
HC4A348**A	1,2	X	0	X	X	1097.0	1131.9	433.4	468.3	774.7	498.5	893.8	1011.6	368.3	215.9	479.4	22.2	87.3	165.1	129.0	140.4	1282.7 X 520.7 X 1173.1	
HC4A360**A	1,2	X	0	X	X	1097.0	1131.9	433.4	468.3	774.7	498.5	893.8	1011.6	368.3	215.9	479.4	22.2	87.3	165.1	133.6	145.0	1282.7 X 520.7 X 1173.1	

208-230-160
230-160
208/230-3-60
460-3-60

X = YES
O = NO

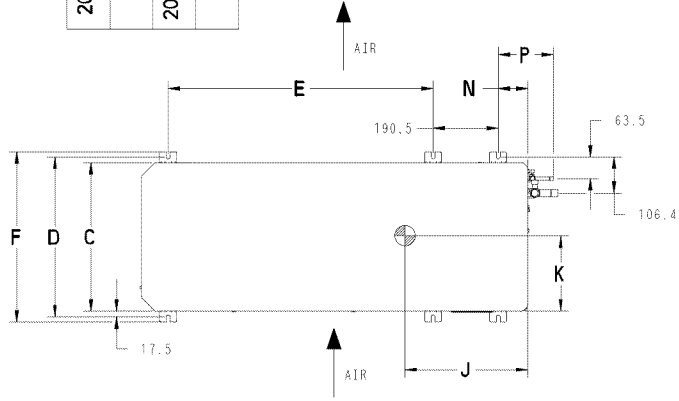

- REQUIRED CLEARANCES: WITH COIL FACING WALL; ALLOW 152.4 MIN CLEARANCE ON COIL SIDE AND COIL END AND 914.4 MIN CLEARANCE ON COMPRESSOR END AND FAN SIDE. WITH FAN FACING WALL; ALLOW 203.2 MIN CLEARANCE ON FAN SIDE AND COIL END AND 914.4 MIN CLEARANCE ON COMPRESSOR END AND COIL SIDE. WITH MULTI UNIT APPLICATION; ARRANGE UNITS SO DISCHARGE OF ONE DOES NOT ENTER INLET OF ANOTHER.
- MINIMUM OUTDOOR OPERATING AMBIENT IN COOLING MODE IS 12.8°C, MAX. 51.7°C.
- SERIES DESIGNATION IS THE 10TH POSITION OF THE UNIT MODEL NUMBER.
- CENTER OF GRAVITY
- ALL DIMENSIONS ARE IN "MM" UNLESS NOTED.

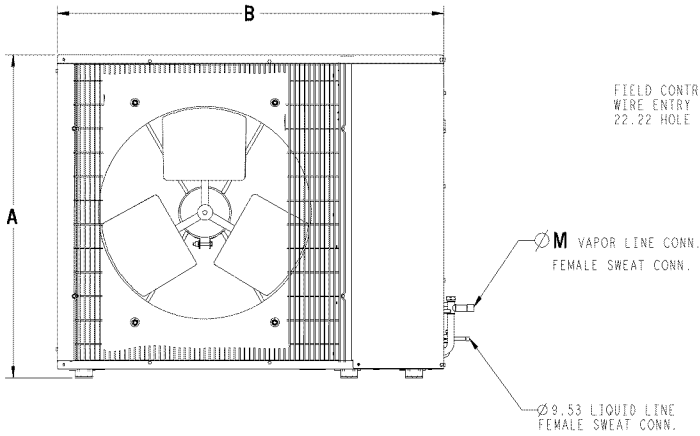

FIELD CONTROL SUPPLY WIRE ENTRY 22.22 HOLE W/GROMMET

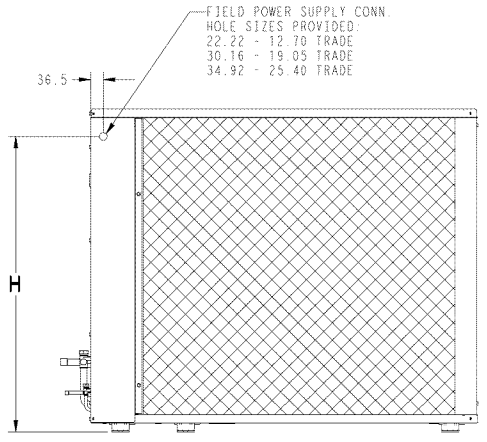
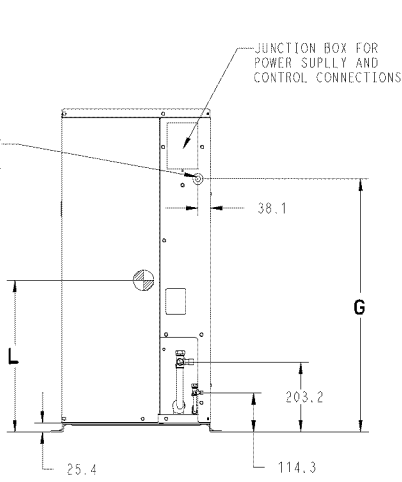

MEASUREMENT- METRIC "SI"
SD4834-4-B

UNIT SIZE	MINIMUM MOUNTING PAD DIMENSIONS
18,24	584.2 X 1066.8
30,36,48,60	609.6 X 1270.0

Fig. 3 - HC4A3 Unit Dimensions

Rigging

⚠ CAUTION

PERSONAL INJURY AND/OR EQUIPMENT DAMAGE HAZARD

Failure to follow this caution may result in personal injury and/or equipment damage.
Be sure unit panels are securely in place prior to rigging.

Keep the unit upright and lift unit using a sling. Use cardboard or padding under the sling, and spreader bars to prevent sling damage to the unit. See Fig. 4. See Fig. 2 for center of gravity reference. Install the unit so that the coil does not face into prevailing winds. If this is not possible and constant winds above 25 mph are expected, use accessory wind baffle. See installation instructions provided with the accessory kit.

NOTE: Accessory wind baffles should be used on all units with accessory low ambient temperature control.

Field-fabricated snow or ice stands may be used to raise unit when operation will be required during winter months. Units may also be wall mounted using the accessory wall mounting kit.

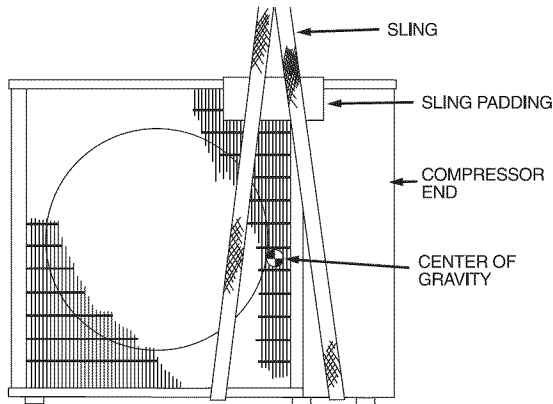

Fig. 4 – Lifting Unit with Sling

A07396

Step 3 —COMPLETE REFRIGERANT PIPING CONNECTIONS

Outdoor units may be connected to indoor units using field-supplied tubing of refrigerant grade and condition. See Table 1 for correct line sizes. Do not use less than 10 ft (3.05 m) of interconnecting tubing.

⚠ CAUTION

UNIT DAMAGE HAZARD

Failure to follow this caution may result in equipment damage or improper operation.

If any section of pipe is buried, there must be a 6 in. (152.4 mm) vertical rise to the valve connections on the outdoor unit. If more than the recommended length is buried, refrigerant may migrate to cooler, buried section during extended periods of system shutdown. This causes refrigerant slugging and could possibly damage the compressor at start-up.

When more than 80 ft (24.38 m) of interconnecting tubing and more than 20 ft (6.10 m) of vertical lift is used, consult the residential Long Line Application Guide for required accessories. If either refrigerant tubing or indoor coil is exposed to the atmosphere, the system must be evacuated following good refrigeration practices.

Run refrigerant tubes as directly as possible, avoiding unnecessary turns and bends. Suspend refrigerant tubes so they do not damage insulation on vapor tube and do not transmit vibration to structure. Also, when passing refrigerant tubes through a wall, seal the opening so that vibration is not transmitted to structure. Leave some slack in refrigerant tubes between structure and outdoor unit to absorb vibration. Refer to separate indoor unit installation instructions for additional information.

Expansion Device

A hard shutoff, thermostatic expansion valve (TXV) is required at the indoor section of the system for proper operation of these products. If the indoor section of the system is not equipped with a hard shutoff TXV, refer to Spec Sheet for the correct TXV kit to be installed. Follow the instructions in the kit for proper installation.

Filter Drier

The filter drier must be replaced whenever the refrigeration system is exposed to the atmosphere.

Refer to Fig. 5 and install filter drier as follows:

1. Braze 5-in. (127 mm) liquid tube to the indoor coil.
2. Wrap filter drier with damp cloth.
3. Braze filter drier to above 5-in. (127 mm) liquid tube. Flow arrow must point towards indoor coil.
4. Connect and braze liquid refrigerant tube to the filter drier.

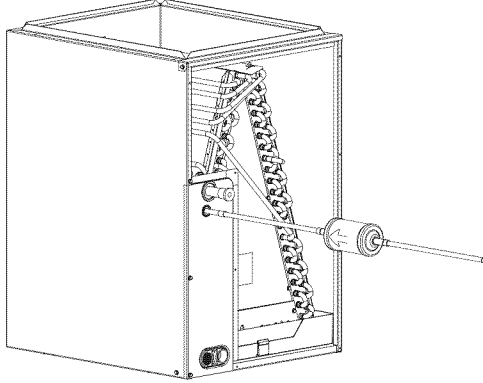

A05178

Fig. 5 – Filter Drier Components

Only use factory specified liquid-line filter driers with rated working pressures less than 600 psig.

NOTE: Do not install a suction-line filter drier in liquid line.

Make Piping Sweat Connections

Remove plastic caps from liquid and suction service valves. Use refrigerant grade tubing. Service valves are closed from the factory and are ready for brazing. After wrapping the service valve with a wet cloth, the tubing set can be brazed to the service valve using either silver bearing or non-silver bearing brazing material. Consult local code requirements. Refrigerant tubing and the indoor coil are now ready for leak testing.

NOTE: Unit is shipped with R-410A refrigerant factory charge indicated on nameplate.

Pass nitrogen or other inert gas through piping while brazing to prevent formation of copper oxide.



CAUTION

UNIT DAMAGE HAZARD

Failure to follow this caution may result in equipment damage or improper operation.

To prevent damage to unit or service valves observe the following:

- Use a brazing shield.
- Wrap service valves with wet cloth or use a heat sink material.

Provide Safety Relief

A fusible plug is located in unit suction line; do not cap this plug. If local code requires additional safety devices, install as directed.

Table 1—HC4A318–60 Physical Data

UNIT HC4A3	18	24A*A1	30	36	48A*A1	60
NOMINAL CAPACITY Tons (kg)	1.5 (1360.8)	2.0 (1814.4)	2.50 (2268.0)	3.0 (2721.6)	4.0 (3628.8)	5.0 (4536.0)
OPERATING WEIGHT lb (kg)	155 (70)	180 (82)	200 (91)	218 (99)	284 (129)	294 (134)
REFRIGERANT TYPE	R-410A					
METERING DEVICE	TXV					
CHARGE* lb (kg)	6.3 (2.86)	6.5 (2.95)	8.7 (3.95)	8.7 (3.95)	12.0 (5.45)	12.0 (5.45)
		24A*A2			48A*A2	
		6.0 (2.73)			11.5 (5.23)	
Note: A*A1 and A*A2 Indicates AKA, AHA, or ALA						
COMPRESSOR						
Type	Scroll					
Oil Charge (POE –oz)	25.0	25.0	25.0	25.0	42.0	42.0
Crankcase Heater (watts)	—	—	40	40	40	40
OUTDOOR FAN						
Rpm/Cfm	840/1720	840/1720	850/3900	850/3900	850/3900	850/3900
Diameter (in.)	18	18	24	24	24	24
No. Blades	3	3	3	3	3	3
Motor (hp)	1/8	1/8	1/4	1/4	1/4	1/4
OUTDOOR COIL						
Face Area (sq ft)	5.8	7.3	12.1	12.1	14.1	14.1
No. Rows	2	2	2	2	2	2
FPI	20	20	20	20	20	20
HIGH PRESSURE SWITCH						
Cut–In (psig)	420 ± 25	420 ± 25	420 ± 25	420 ± 25	420 ± 25	420 ± 25
Cutout (psig)	650 ± 10	650 ± 10	650 ± 10	650 ± 10	650 ± 10	650 ± 10
REFRIGERANT LINES						
Connection Type	Sweat					
Liquid Line (in.) OD	3/8	3/8	3/8	3/8	3/8	3/8
Vapor Line (in.) OD	5/8	5/8	3/4	3/4	7/8	7/8†
Max Length (ft)	200	200	200	200	200	200
Max Lift (ft)**	65	65	65	65	65	65
Max Drop (ft)	150	150	150	150	150	150
CONTROLS						
Control Voltage‡	24 vac					
System Voltage	208/230 v	208/230 v	208/230 v	208/230 v, Single and 3 Phase, 460 v, 3 Phase		
FINISH	Gray					

* Unit shipped with full factory charge. See ARI (Air Conditioning and Refrigeration Institute) capacity table for proper charge and piston for each fan coil type.

† Valve connection size is 7/8 inch. Recommended line size is 1–1/8 inches.

‡ 24 v and a minimum of 40 va is provided in the fan coil unit.

FPI – Fins Per Inch

POE – Polyol Ester

Step 4 —Make Electrical connections



WARNING

ELECTRICAL SHOCK HAZARD

Failure to follow this warning could result in personal injury or death.

The unit cabinet must have an uninterrupted or unbroken ground to minimize personal injury if an electrical fault should occur. The ground may consist of electrical wire or metal conduit when installed in accordance with existing electrical codes.



CAUTION

UNIT DAMAGE HAZARD

Failure to follow this caution may result in equipment damage or improper operation.

Unit failure as a result of operation on improper line voltage or excessive phase imbalance constitutes abuse and may cause damage to electrical components. Such operation would void any applicable warranty.



WARNING

ELECTRICAL SHOCK HAZARD

Failure to follow this warning could result in personal injury or death.

Before performing service or maintenance, be sure indoor unit main power switch is turned OFF and indoor blower has stopped.

Control Circuit Wiring

Control voltage is 24 v (40 va minimum). See Fig. 6 and unit label diagram for field-supplied wiring details. Route control wire through opening in unit side panel to connection in unit control box.

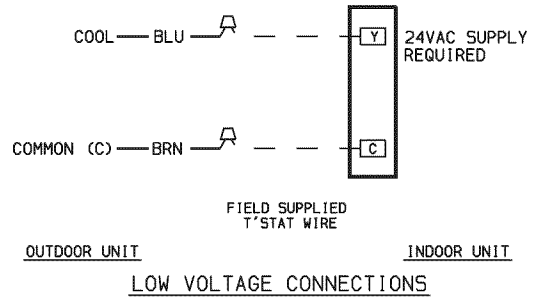

A07398

Fig. 6 – HC4A3 Typical Control Circuit Connections

NOTE: Use No. 18 AWG color-coded, insulated (35°C minimum) wire. If thermostat is located more than 100 ft (30.48 m) from unit, as measured along the control voltage wires, use No. 16 AWG color-coded wire to avoid excessive voltage drop.

NOTE: All wiring must conform to NEC and local codes.

NOTE: Operating unit on improper line voltage constitutes abuse and could affect warranty. See Table 2. **Do not** install unit in a system where voltage may fluctuate above or below permissible limits.

See Table 2 for recommended fuse sizes. When making electrical connections, provide clearance at the unit for refrigerant piping connections.

NOTE: The HC4A3 units use the control transformer supplied with the matched indoor unit.

Power Wiring

Unit is factory wired for voltage shown on nameplate. Provide adequate, fused disconnect switch within sight from unit, readily accessible, but out of reach of children. Provision for locking the switch open (off) is advisable to prevent power from being turned on while unit is being serviced.

Disconnect switch, fuses, and field wiring must comply with the NEC and local code requirements. Use copper wire only between the disconnect switch and unit. Use minimum 75C wire for the field power connection.

Route power wires through the opening in unit side panel and connect in the unit control box as shown on the unit label diagram and Fig. 7. Unit must be grounded.

Connections to Duct Free Fan Coil Units

The HC4A3 units are designed for easy match-up to underceiling duct free fan coils. This unit provides 24 v power for the outdoor unit from the fan coil. Connect the Y and C terminals of the indoor unit to the Y and C terminals.

Table 2—HC4A3 Electrical Data

HC4A3 UNIT SIZE	V-PH-Hz	VOLTAGE RANGE*		COMPRESSOR		OUTDOOR FAN MOTOR			MIN CKT AMPS	FUSE/CKT BKR AMPS
		Min	Max	RLA	LRA	FLA	NEC Hp	kw Out		
18AKA1	208/230-1-60	187	253	9.0	48.0	0.80	0.125	0.09	12.1	20
24AKA1	208/230-1-60	187	253	12.8	58.3	0.80	0.125	0.09	16.8	25
24AKA2	208/230-1-60	187	253	13.5	58.3	0.80	0.125	0.09	17.7	25
30AKA1	208/230-1-60	187	253	14.1	73.0	1.5	0.25	0.19	19.1	30
36AKA1	208/230-1-60	187	253	14.1	77.0	1.5	0.25	0.19	19.1	30
36AHA1	208/230-3-60	187	253	9.0	71.0	1.5	0.25	0.19	12.7	20
36ALA1	460-3-60	414	506	5.6	38.0	0.80	0.25	0.19	7.8	15
48AKA1	208/230-1-60	187	253	21.8	117.0	1.5	0.25	0.19	28.7	50
48AHA1	208/230-3-60	187	253	13.7	83.1	1.5	0.25	0.19	18.6	30
48ALA1	460-3-60	414	506	6.2	41.0	0.80	0.25	0.19	8.6	15
48AKA2	208/230-1-60	187	253	19.9	109.0	1.5	0.25	0.19	26.4	40
48AHA2	208/230-3-60	187	253	13.1	83.1	1.5	0.25	0.19	17.9	25
48ALA2	460-3-60	414	506	6.1	41.0	0.80	0.25	0.19	8.4	15
60AKA1	208/230-1-60	187	253	26.4	134.0	1.5	0.25	0.19	34.5	60
60AHA1	208/230-3-60	187	253	16.0	110.0	1.5	0.25	0.19	21.5	35
60ALA1	460-3-60	414	506	7.8	52.0	0.80	0.25	0.19	10.6	15
60AKA2	208/230-1-60	187	253	26.4	134.0	1.5	0.25	0.19	34.5	60
60AHA2	208/230-3-60	187	253	15.0	110.0	1.5	0.25	0.19	21.5	30
60ALA2	460-3-60	414	506	7.8	52.0	0.80	0.25	0.19	10.6	15

LEGEND:

- FLA — Full Load Amps
- LRA — Locked Rotor Amps
- NEC — National Electrical Code
- RLA — Rated Load Amps (compressor)

* Permissible limits of the voltage range at which the unit will operate satisfactorily

NOTES:

1. Control circuit is 24-V on all units and requires external power source. Copper wire must be used from service disconnect to unit.
2. All motors/compressors contain internal overload protection.
3. In compliance with NEC (U.S.A. Standard) requirements for multimotor and combination load equipment (refer to NEC Articles 430 and 440), the overcurrent protective device for the unit shall be fuse or breaker.
4. Motor RLA values are established in accordance with UL (Underwriters' Laboratories) Standard 465 (U.S.A. Standard).
5. HC4A318-30 units are only available in single-phase voltage.
6. **Unbalanced 3-Phase Supply Voltage**

Never operate a motor where a phase imbalance in supply voltage is greater than 2%. Use the following formula to determine the percentage of voltage imbalance:

$$= 100 \times \frac{\text{max voltage deviation from average voltage}}{\text{average}}$$

EXAMPLE: Supply voltage is 460-3-60

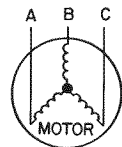

AB = 452v
BC = 464v
AC = 455v

$$\begin{aligned} \text{Average Voltage} &= \frac{452 + 464 + 455}{3} \\ &= \frac{1371}{3} \\ &= 457 \end{aligned}$$

Determine maximum deviation from average voltage:

(AB) 457-452 = 5v

(BC) 464-457 = 7v

(AC) 457-455 = 2v

Maximum deviation is 7v.

Determine percentage of voltage imbalance

$$\begin{aligned} \% \text{ of voltage imbalance} &= 100 \times \frac{7}{57} \\ &= 1.53\% \end{aligned}$$

This amount of phase imbalance is satisfactory as it is below the maximum allowable of 2%.

IMPORTANT: Contact your local electric utility company immediately if the supply voltage phase imbalance is more than 2%.



Fig. 7 - HC4A318-60 Typical Wiring Schematic

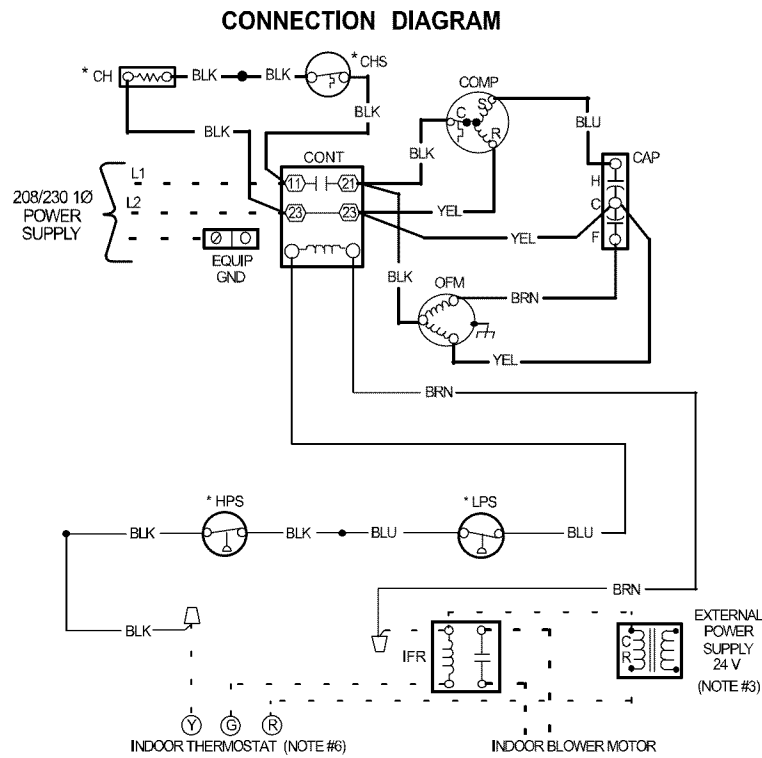

SCHEMATIC DIAGRAM (LADDER FORM)

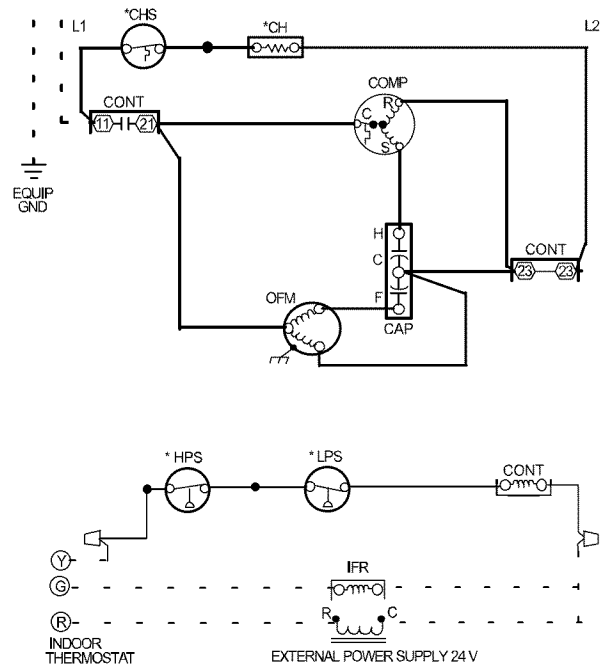

LEGEND

- FACTORY POWER WIRING
- FACTORY CONTROL WIRING
- - - FIELD CONTROL WIRING
- · - FIELD POWER WIRING
- COMPONENT CONNECTION
- ⊕ FIELD SPLICE
- JUNCTION
- CONT CONTACTOR
- CAP CAPACITOR (DUAL RUN)
- *CH CRANKCASE HEATER
- *CHS CRANKCASE HEATER SWITCH
- COMP COMPRESSOR
- *CTD COMPRESSOR TIME DELAY
- HPS HIGH PRESSURE SWITCH
- IFR INDOOR FAN RELAY
- LPS LOW PRESSURE SWITCH
- OFM OUTDOOR FAN MOTOR

* MAY BE FACTORY OR FIELD INSTALLED

NOTES:

1. Symbols are electrical representation only.
2. Compressor and fan motor furnished with inherent thermal protection.
3. To be wired in accordance with National Electric N.E.C. and local codes.
4. N.E.C. class 2, 24 V circuit, min. 40 VA required, 60 VA on units installed with LLS.
5. Use copper conductors only. Use conductors suitable for at least 75°C (167°F).
6. Connection for typical cooling only thermostat. For other arrangements see installation instructions.
7. If indoor section has a transformer with a grounded secondary, connect the grounded side to the BRN lead.
8. If any of the original wire, as supplied must be replaced, use the same or equivalent wire.
9. Check all electrical connections inside control box for tightness.
10. Do not attempt to operate unit until service valves have been opened.
11. Do not rapid cycle compressor. Compressor must be off 3 minutes to allow pressures to equalize between high and low side before starting.

HC4A3 OPERATION SEQUENCE

CALL FOR COOLING:

1. Control voltage from transformer to thermostat (24 v).
2. At thermostat 24 v is switched to "G" and "Y."
3. 24 v from thermostat "G" energizes fan relay at indoor fan coil and indoor-fan motor runs.
4. 24 v from thermostat "Y" energizes the contactor coil at the outdoor unit. Compressor and outdoor-fan motor run.
5. If the internal protector of the compressor, HPS, or LPS open, the 24 v to the contactor coil will be interrupted, and compressor and outdoor fan motor will stop.

START-UP

Step 1 —Preliminary Checks

1. Check that all internal wiring connections are tight and that all barriers, covers, and panels are in place.
2. Field electrical power source must agree with unit nameplate rating.
3. All service valves must be open.
4. Belly-band crankcase heater must be tight on compressor crankcase for those units with belly-band heaters.

Step 2 —Leak Test

Field piping and fan coil must be leak tested by pressure method. Use R-410A refrigerant at approximately 25 psig backed up with an inert gas to a total pressure not to exceed 245 psig.

Step 3 —Evacuate and Dehydrate

Field piping and fan coil must be evacuated and dehydrated.

Step 4 —Charge System

Release charge into system by opening (backseating) liquid and suction line service valves.

Step 5 —To Start Unit

Be sure that the field disconnect is closed. Set room thermostat below ambient temperature. Operate unit for 15 minutes, then check system refrigerant charge. See Refrigerant Charging section on page 12.

NOTE: When using in conjunction with underceiling fan coils, refer to start-up instructions included with fan coil for correct start-up procedures.

SERVICE



WARNING

ELECTRICAL SHOCK HAZARD

Failure to follow this warning could result in personal injury or death.

Before installing, modifying, or servicing system, main electrical disconnect switch must be in the OFF position. There may be more than 1 disconnect switch. Lock out and tag switch with a suitable warning label.

Outdoor Fan

A reinforced wire mount holds the outdoor fan assembly in position. See Fig. 8 for proper mounting position.

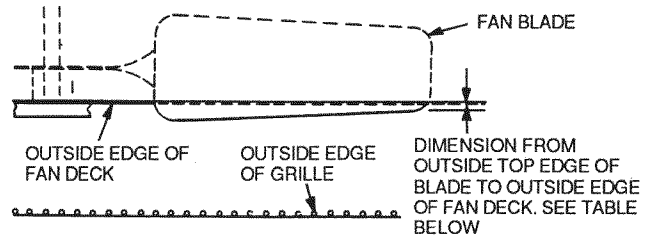

HC4A3 Unit Size, in. (mm)		
18,24	30,36	48,60
0.433 (11.00)	0	0

A07401

Fig. 8 — Condenser Fan Mounting Positions

High-Pressure Relief Valve

The high-pressure relief valve is located in the compressor. The relief valve opens at a pressure differential of approximately 550 to 625 ± 50 psig between suction (low side) and discharge (high side) to allow pressure equalization.

Internal Current and Temperature Sensitive Overload

The control resets automatically when internal compressor motor temperature drops to a safe level (overloads may require up to 45 minutes to reset). When an internal overload is suspected of being open, check by using an ohmmeter or continuity tester.

Pumpdown Procedure

The system may be pumped down in order to make repairs on the low side without losing complete refrigerant charge.



CAUTION

UNIT DAMAGE HAZARD

Failure to follow this caution may result in equipment damage or improper operation.

Never open system to atmosphere while it is under a vacuum.

When system must be opened for service, recover refrigerant, break vacuum with dry nitrogen before opening system.

1. Attach pressure gage to suction service valve gage port.
2. Frontseat the liquid/mixed phase line valve.
3. Start unit and run until suction pressure reaches 20 psig.
4. Shut unit off and frontseat suction valve.
5. De-pressurize low side of unit and recover refrigerant following accepted practices.

Crankcase Heater

The crankcase heater prevents refrigerant migration and compressor oil dilution during shutdown when compressor is not operating. If the crankcase heater is de-energized for more than 6 hours, both compressor service valves must be closed.

NOTE: Crankcase heaters are only available on HC4A3030-060 units.

The crankcase heater is powered by the high-voltage power of the unit. It is connected across the line side of the contactor and is thermostatically controlled.



WARNING

PERSONAL INJURY HAZARD

Failure to follow this warning could result in personal injury or death.

Use extreme caution when troubleshooting this device as line voltage is continually present.

To troubleshoot:

1. Apply voltmeter across crankcase heater leads to see if heater voltage is on. Do not touch heater. Carefully feel area around crankcase heater; if warm, crankcase heater is functioning.
2. With power off and heater leads disconnected, check across leads with ohmmeter. Do not look for a specific resistance reading. Check for resistance or an open circuit, and change heater if an open circuit is detected.

Service Valves

The service valves in the outdoor unit come from the factory frontseated. This means the refrigerant charge is isolated from the line-set connection ports. To prevent damage to the valve, use a wet cloth or other accepted heat sink material on the valve before brazing.

The service valve cannot be field repaired, therefore, only a complete valve or valve stem seal and service port caps are available for replacement.

Refrigerant Charging



WARNING

PERSONAL INJURY AND/OR EQUIPMENT DAMAGE HAZARD

Failure to follow this warning could result in personal injury and/or equipment damage.

Wear safety glasses and gloves when handling refrigerant. Do not overcharge system – this can cause compressor flooding.



WARNING

PERSONAL INJURY AND/OR EQUIPMENT DAMAGE HAZARD

Failure to follow this warning could result in personal injury and/or equipment damage.

Service valves must be fully backseated to close service port. There is no Schrader valve at the service port, and failure to backseat the valve could result in loss of system charge or personal injury.

NOTE: Do not vent or de-pressurize unit refrigerant to atmosphere. Remove and recover refrigerant following accepted practices.

All units are shipped with the refrigerant charge listed on the nameplate.

Refer to Table 3 and consider the following when working with R-410A refrigerant:

- R-410A refrigerant cylinders are rose colored.
- Recovery cylinder service pressure rating must be 400 psig, DOT (Department of Transportation) 4BA400 or DOT BW400.
- R-410A systems should be charged with liquid refrigerant. Use a commercial type metering device in the manifold hose when charging into suction line with compressor operating.
- Manifold sets should be 700 psig high side and 180 psig low side with 550 psig low-side retard.
- Use hoses with 700 psig service pressure rating.
- R-410A refrigerant, as with other HFCs, is only compatible with POE oils.
- Vacuum pumps will not remove moisture from oil.
- Polyol Ester oils absorb moisture rapidly. Do not expose oil to atmosphere.
- Polyol Ester oils may cause damage to certain plastics and roofing materials.
- Wrap all filter driers and service valves with wet cloth when brazing.
- Factory approved, liquid-line filter drier is required on every unit.
- Do not use a TXV (thermostatic expansion valve) designed for use with R-22 refrigerant. Refer to separate indoor unit installation instructions for more details.
- If using a suction line drier, do not leave in place for more than 72 hours.

Table 3—Pressure vs. Temperature Chart – R-410A Refrigerant

PRESSURE			TEMPERATURE			PRESSURE			TEMPERATURE			PRESSURE			TEMPERATURE			PRESSURE			TEMPERATURE		
PSIG	°F	°C	PSIG	°F	°C	PSIG	°F	°C	PSIG	°F	°C	PSIG	°F	°C	PSIG	°F	°C	PSIG	°F	°C	PSIG	°F	°C
12	-37.7	-38.72	114	37.8	3.22	216	74.3	23.50	318	100.2	37.89	420	120.7	49.28	522	137.6	58.67	624	154.5	68.06	726	171.4	77.45
14	-34.7	-37.06	116	38.7	3.72	218	74.9	23.83	320	100.7	38.17	422	121.0	49.44	524	137.9	58.83	626	154.7	68.23	728	171.6	77.62
16	-32.0	-35.56	118	39.5	4.17	220	75.5	24.17	322	101.1	38.39	424	121.4	49.67	526	138.3	59.06	628	155.1	68.46	730	171.9	77.81
18	-29.4	-34.11	120	40.5	4.72	222	76.1	24.50	324	101.6	38.67	426	121.7	49.83	528	138.6	59.22	630	155.4	68.62	732	172.1	78.00
20	-26.9	-32.72	122	41.3	5.17	224	76.7	24.83	326	102.0	38.89	428	122.1	50.06	530	138.9	59.39	632	155.7	68.78	734	172.3	78.17
22	-24.5	-31.90	124	42.2	5.67	226	77.2	25.11	328	102.4	39.11	430	122.5	50.28	532	139.2	59.56	634	156.0	68.94	736	172.5	78.34
24	-22.2	-30.11	126	43.0	6.11	228	77.8	25.44	330	102.9	39.39	432	122.8	50.44	534	139.5	59.72	636	156.3	69.10	738	172.7	78.51
26	-20.0	-28.89	128	43.8	6.56	230	78.4	25.78	332	103.3	39.61	434	123.2	50.67	536	139.8	59.89	638	156.6	69.26	740	172.9	78.68
28	-17.9	-27.72	130	44.7	7.06	232	78.9	26.06	334	103.7	39.83	436	123.5	50.83	538	140.1	60.06	640	156.9	69.42	742	173.1	78.85
30	-15.8	-26.61	132	45.5	7.50	234	79.5	26.39	336	104.2	40.11	438	123.9	51.06	540	140.4	60.22	642	157.2	69.58	744	173.3	79.02
32	-13.8	-25.44	134	46.3	7.94	236	80.0	26.67	338	104.6	40.33	440	124.2	51.22	544	141.0	60.56	644	157.8	69.82	746	173.5	79.19
34	-11.9	-24.39	136	47.1	8.39	238	80.6	27.00	340	105.1	40.61	442	124.6	51.44	548	141.6	60.89	646	158.4	70.06	748	173.7	79.36
36	-10.1	-23.39	138	47.9	8.83	240	81.1	27.28	342	105.4	40.78	444	124.9	51.61	552	142.1	61.17	648	159.0	70.22	750	173.9	79.53
38	-8.3	-22.39	140	48.7	9.28	242	81.6	27.56	344	105.8	41.00	446	125.3	51.83	556	142.7	61.50	650	159.6	70.38	752	174.1	79.70
40	-6.5	-21.39	142	49.5	9.72	244	82.2	27.89	346	106.3	41.28	448	125.6	52.00	560	143.3	61.83	652	160.2	70.54	754	174.3	79.87
42	-4.5	-20.28	144	50.3	10.17	246	82.7	28.17	348	106.6	41.44	450	126.0	52.22	564	143.9	62.17	654	160.8	70.70	756	174.5	80.04
44	-3.2	-19.56	146	51.1	10.61	248	83.3	28.50	350	107.1	41.72	452	126.3	52.39	568	144.5	62.50	656	161.4	70.86	758	174.7	80.21
46	-1.6	-18.67	148	51.8	11.00	250	83.8	28.78	352	107.5	41.94	454	126.6	52.56	572	145.0	62.78	658	162.0	71.02	760	174.9	80.38
48	0.0	-17.78	150	52.5	11.39	252	84.3	29.06	354	107.9	42.17	456	127.0	52.78	576	145.6	63.11	660	162.6	71.18	762	175.1	80.55
50	1.5	-16.94	152	53.3	11.83	254	84.8	29.33	356	108.3	42.39	458	127.3	52.94	580	146.2	63.44	662	163.2	71.34	764	175.3	80.72
52	3.0	-16.11	154	54.0	12.22	256	85.4	29.67	358	108.8	42.67	460	127.7	53.17	584	146.7	63.72	664	163.8	71.50	766	175.5	80.89
54	4.5	-15.28	156	54.8	12.67	258	85.9	29.94	360	109.2	42.89	462	128.0	53.33	588	147.3	64.06	666	164.4	71.66	768	175.7	81.06
56	5.9	-14.50	158	55.5	13.06	260	86.4	30.22	362	109.6	43.11	464	128.3	53.50	592	147.9	64.39	668	165.0	71.82	770	175.9	81.23
58	7.3	-13.72	160	56.2	13.44	262	86.9	30.50	364	110.0	43.33	466	128.7	53.72	596	148.4	64.67	670	165.6	71.98	772	176.1	81.40
60	8.6	-13.00	162	57.0	13.89	264	87.4	30.78	366	110.4	43.56	468	129.0	53.89	600	149.0	65.00	672	166.2	72.14	774	176.3	81.57
62	10.0	-12.22	164	57.7	14.28	266	87.9	31.06	368	110.8	43.78	470	129.3	54.06	604	149.5	65.28	674	166.8	72.30	776	176.5	81.74
64	11.3	-11.50	166	58.4	14.67	268	88.4	31.33	370	111.2	44.00	472	129.7	54.28	608	150.1	65.61	676	167.4	72.46	778	176.7	81.91
66	12.6	-10.78	168	59.0	15.00	270	88.9	31.61	372	111.6	44.22	474	130.0	54.44	612	150.6	65.89	678	168.0	72.62	780	176.9	82.08
68	13.8	-10.11	170	59.8	15.44	272	89.4	31.89	374	112.0	44.44	476	130.3	54.61	616	151.2	66.22	680	168.6	72.78	782	177.1	82.25
70	15.1	-9.39	172	60.5	15.83	274	89.9	32.17	376	112.4	44.67	478	130.7	54.83	620	151.7	66.50	682	169.2	72.94	784	177.3	82.42
72	16.3	-8.72	174	61.1	16.17	276	90.4	32.44	378	112.6	44.78	480	131.0	55.00	624	152.3	66.83	684	169.8	73.10	786	177.5	82.59
74	17.5	-8.06	176	61.8	16.56	278	90.9	32.72	380	113.1	45.06	482	131.3	55.17	628	152.8	67.11	686	170.4	73.26	788	177.7	82.76
76	18.7	-7.39	178	62.5	16.94	280	91.4	33.00	382	113.5	45.28	484	131.6	55.33	632	153.4	67.44	688	171.0	73.42	790	177.9	82.93
78	19.8	-6.78	180	63.1	17.28	282	91.9	33.28	384	113.9	45.50	486	132.0	55.56	636	153.9	67.72	690	171.6	73.58	792	178.1	83.10
80	21.0	-6.11	182	63.8	17.67	284	92.4	33.56	386	114.3	45.72	488	132.3	55.72	640	154.5	68.06	692	172.2	73.74	794	178.3	83.27
82	22.1	-5.50	184	64.5	18.06	286	92.8	33.78	388	114.7	45.94	490	132.6	55.89	644	155.0	68.33	694	172.8	73.90	796	178.5	83.44
84	23.2	-4.89	186	65.1	18.39	288	93.3	34.06	390	115.0	46.11	492	132.9	56.06	648	155.5	68.61	696	173.4	74.06	798	178.7	83.61
86	24.3	-4.28	188	65.8	18.78	290	93.8	34.33	392	115.5	46.39	494	133.3	56.28	652	156.1	68.94	698	174.0	74.22	800	178.9	83.78
88	25.4	-3.67	190	66.4	19.11	292	94.3	34.61	394	115.8	46.56	496	133.6	56.44	656	156.6	69.22	700	174.6	74.38	802	179.1	83.95
90	26.4	-3.11	192	67.0	19.44	294	94.8	34.89	396	116.2	46.78	498	133.9	56.61	660	157.1	69.50	702	175.2	74.54	804	179.3	84.12
92	27.4	-2.56	194	67.7	19.83	296	95.2	35.11	398	116.6	47.00	500	134.0	56.67	664	157.7	69.83	704	175.8	74.70	806	179.5	84.29
94	28.5	-1.94	196	68.3	20.17	298	95.7	35.39	400	117.0	47.22	502	134.5	56.94	668	158.2	70.11	706	176.4	74.86	808	179.7	84.46
96	29.5	-1.39	198	68.9	20.50	300	96.2	35.67	402	117.3	47.39	504	134.8	57.11	672	158.7	70.39	708	177.0	75.02	810	179.9	84.63
98	30.5	-0.83	200	69.5	20.83	302	96.6	35.89	404	117.7	47.61	506	135.2	57.33	676	159.2	70.67	710	177.6	75.18	812	180.1	84.80
100	31.2	-0.44	202	70.1	21.17	304	97.1	36.17	406	118.1	47.83	508	135.5	57.50	680	159.8	71.00	712	178.2	75.34	814	180.3	84.97
102	32.2	0.11	204	70.7	21.50	306	97.5	36.39	408	118.5	48.06	510	135.8	57.67	684	160.3	71.28	714	178.8	75.50	816	180.5	85.14
104	33.2	0.67	206	71.4	21.89	308	98.0	36.67	410	118.8	48.22	512	136.1	57.83	688	160.8	71.56	716	179.4	75.66	818	180.7	85.31
106	34.1	1.17	208	72.0	22.22	310	98.4	36.89	412	119.2	48.44	514	136.4	58.00	692	161.3	71.83	718	180.0	75.82	820	180.9	85.48
108	35.1	1.72	210	72.6	22.56	312	98.9	37.17	414	119.6	48.67	516	136.7	58.17	696	161.8	72.11	720	180.6	75.98	822	181.1	85.65
110	35.5	1.94	212	73.2	22.89	314	99.3	37.39	416	119.9	48.83	518	137.0	58.33	—	—	—	722	181.2	76.14	824	181.3	85.82
112	36.9	2.72	214	73.8	23.22	316	99.7	37.61	418	120.3	49.06	520	137.3	58.50	—	—	—	724	181.8	76.30	826	181.5	85.99

Subcooling Method

NOTE: Units are charged at the factory for 15 ft of tubing. Adjust charge by plus or minus 0.6 oz per foot of tubing greater or less than 15 ft respectively.

For HC4A3 units, the subcooling method is used to check and adjust charge during the cooling season. Refer to Table 4 and the following procedure:

1. Operate unit a minimum of 15 minutes before checking charge.
2. Measure liquid line temperature near liquid line service valve, and measure the liquid pressure at the liquid line service valve. Use a digital thermometer for all temperature measurements. DO NOT use mercury or dial-type thermometers.

3. Refer to Table 4. Find the temperature point at which the required subcooling temperature intersects the measured liquid line pressure.
4. If the measured liquid line temperature does not agree with the required liquid line temperature, ADD refrigerant to lower the temperature, or REMOVE refrigerant to raise the temperature (allow a tolerance of $\pm 3^{\circ}\text{F}/1.67^{\circ}\text{C}$).

Table 4—Subcooling Charging Table

LIQUID PRESSURE AT SERVICE VALVE	REQUIRED LIQUID LINE TEMPERATURE											
	Required Subcooling Temperature °F (°C)											
	8 (4.4)		10 (5.5)		12 (6.6)		14 (7.7)		16 (8.8)		18 (9.9)	
psig	°F	°C	°F	°C	°F	°C	°F	°C	°F	°C	°F	°C
189	58	32	56	31	54	30	52	29	50	28	48	27
195	60	33	58	32	56	31	54	30	52	29	50	28
202	62	34	60	33	58	32	56	31	54	30	52	29
208	64	36	62	34	60	33	58	32	56	31	54	30
215	66	37	64	36	62	34	60	33	58	32	56	31
222	68	38	66	37	64	36	62	34	60	33	58	32
229	70	39	68	38	66	37	64	36	62	34	60	33
236	72	40	70	39	68	38	66	37	64	36	62	34
243	74	41	72	40	70	39	68	38	66	37	64	36
251	76	42	74	41	72	40	70	39	68	38	66	37
259	78	43	76	42	74	41	72	40	70	39	68	38
266	80	44	78	43	76	42	74	41	72	40	70	39
274	82	46	80	44	78	43	76	42	74	41	72	40
283	84	47	82	46	80	44	78	43	76	42	74	41
291	86	48	84	47	82	46	80	44	78	43	76	42
299	88	49	86	48	84	47	82	46	80	44	78	43
308	90	50	88	49	86	48	84	47	82	46	80	44
317	92	51	90	50	88	49	86	48	84	47	82	46
326	94	52	92	51	90	50	88	49	86	48	84	47
335	96	53	94	52	92	51	90	50	88	49	86	48
345	98	54	96	53	94	52	92	51	90	50	88	49
354	100	56	98	54	96	53	94	52	92	51	90	50
364	102	57	100	56	98	54	96	53	94	52	92	51
374	104	58	102	57	100	56	98	54	96	53	94	52
384	106	59	104	58	102	57	100	56	98	54	96	53
395	108	60	106	59	104	58	102	57	100	56	98	54
406	110	61	108	60	106	59	104	58	102	57	100	56
416	112	62	110	61	108	60	106	59	104	58	102	57
427	114	63	112	62	110	61	108	60	106	59	104	58
439	116	64	114	63	112	62	110	61	108	60	106	59
450	118	66	116	64	114	63	112	62	110	61	108	60
462	120	67	118	66	116	64	114	63	112	62	110	61
474	122	68	120	67	118	66	116	64	114	63	112	62
486	124	69	122	68	120	67	118	66	116	64	114	63
499	126	70	124	69	122	68	120	67	118	66	116	64
511	128	71	126	70	124	69	122	68	120	67	118	66

MAINTENANCE



WARNING

ELECTRICAL SHOCK HAZARD

Failure to follow this warning could result in personal injury or death.

Before installing, modifying, or servicing system, main electrical disconnect switch must be in the OFF position. There may be more than 1 disconnect switch. Lock out and tag switch with a suitable warning label.

LUBRICATION

Compressor

Compressor contains factory oil charge; replace oil when lost. Use Mobile 3MA-POE oil.

CLEANING COILS

Coil should be washed out with water or blown out with compressor air. Note that the blow-thru design causes dirt and debris to build up on the inside of the coils. Clean coil annually or as required by location and outdoor air conditions. Inspect coil monthly and clean as required. Fins are not continuous through coil sections. Dirt and debris may pass through first section, become trapped between the row of fins and restrict condenser airflow. Use a flashlight to determine if dirt or debris has collected between coil sections. Clean coil as follows:

1. Turn off unit power.
2. Using a garden hose or other suitable equipment, flush coil from the outside to remove dirt. Be sure to flush all dirt and debris from drain holes in base of unit. Fan motors are waterproof.

TROUBLESHOOTING

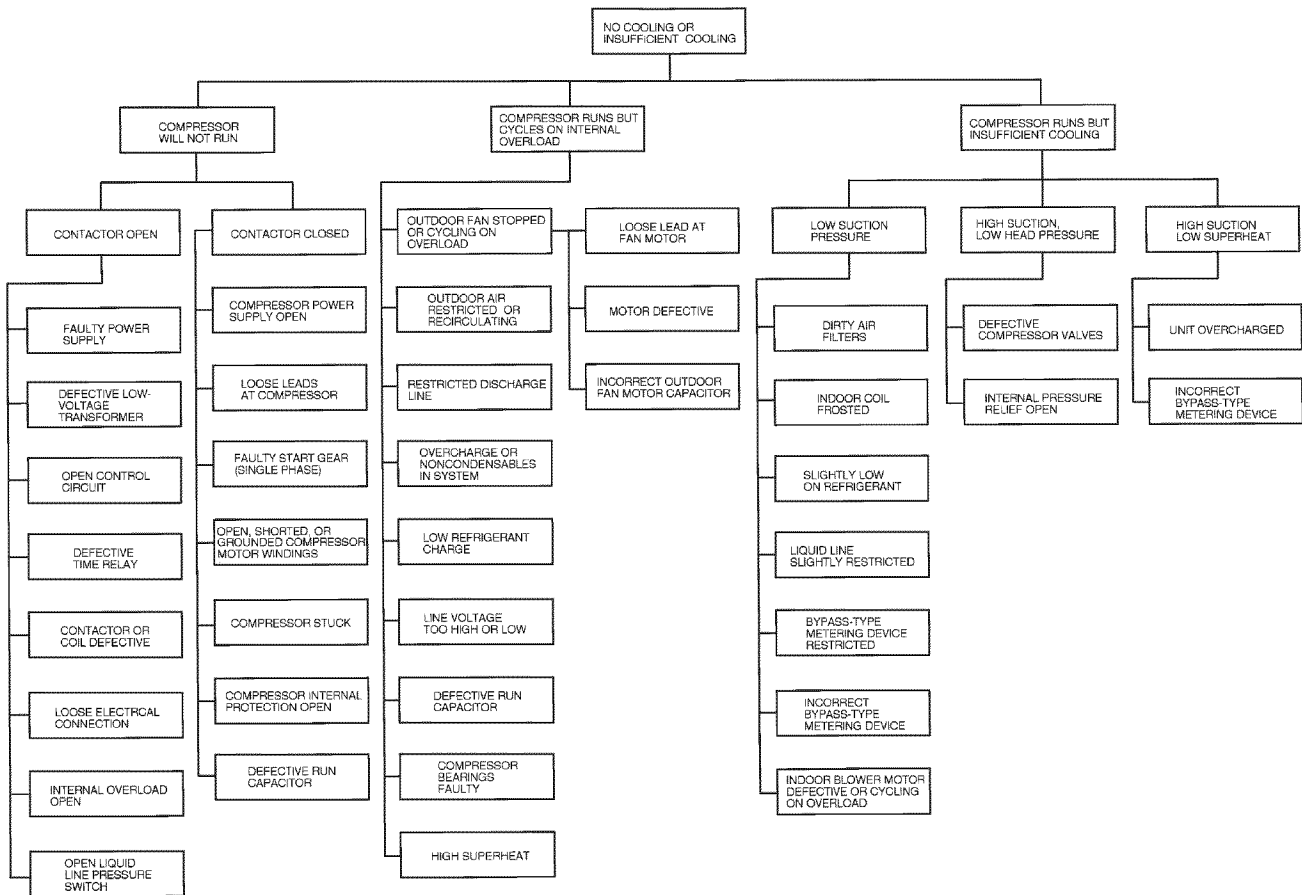

Fig. 9 – Troubleshooting the Cooling Cycle

A07402