

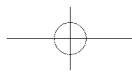

OPERATING INSTRUCTIONS

---

***RX-4503***  
***AM/FM STEREO RECEIVER***



## IMPORTANT SAFETY INSTRUCTIONS

1. Read these instructions.
2. Keep these instructions.
3. Heed all warnings.
4. Follow all instructions.
5. Do not use this apparatus near water.
6. Clean only with dry cloth.
7. Do not block any ventilation openings.  
Install in accordance with the manufacturer's instructions.
8. Do not install near any heat sources such as radiators, heat registers, stoves, or other apparatus (including amplifiers) that produce heat.
9. Do not defeat the safety purpose of the polarized or grounding-type plug. A polarized plug has two blades with one wider than the other.  
A grounding type plug has two blades and a third grounding prong. The wide blade or the third prong are provided for your safety. If the provided plug does not fit into your outlet, consult an electrician for replacement of the obsolete outlet.
10. Protect the power cord from being walked on or pinched particularly at plugs, convenience receptacles, and the point where they exit from the apparatus.
11. Only use attachments accessories specified by the manufacturer.

12. Use only with the cart, stand, tripod, bracket, or table specified by the manufacturer, or sold with the apparatus.  
When a cart is used, use caution when moving the cart/apparatus combination to avoid injury from tip-over.



### PORTABLE CART WARNING

13. Unplug this apparatus during lightning storms or when unused for long periods of time.
14. Refer all servicing to qualified service personnel.  
Servicing is required when the apparatus has been damaged in any way, such as power-supply cord or plug is damaged, liquid has been spilled or objects have fallen into the apparatus, the apparatus have been exposed to rain or moisture, does not operate normally, or has been dropped.



# Introduction

## READ THIS BEFORE OPERATING YOUR UNIT

ENGLISH

 **CAUTION**   
RISK OF ELECTRIC SHOCK  
DO NOT OPEN

**CAUTION :** TO REDUCE THE RISK OF ELECTRIC SHOCK, DO NOT REMOVE COVER (OR BACK). NO USER-SERVICEABLE PARTS INSIDE. REFER SERVICING TO QUALIFIED SERVICE PERSONNEL.

 This symbol is intended to alert the user to the presence of uninsulated "dangerous voltage" within the product's enclosure that may be of sufficient magnitude to constitute a risk of electric shock to persons.

 This symbol is intended to alert the user to the presence of important operating and maintenance (servicing) instructions in the literature accompanying the appliance.

**WARNING :** TO REDUCE THE RISK OF FIRE OR ELECTRIC SHOCK, DO NOT EXPOSE THIS APPLIANCE TO RAIN OR MOISTURE.

### Caution regarding installation

Note : For heat dispersal, do not install this unit in a confined space such as a bookcase or similar enclosure.

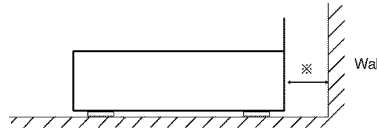
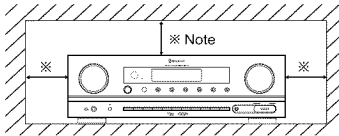

**Do not block ventilation openings or stack other equipment on the top.**

### Note to CATV System Installer :

This reminder is provided to call the CATV system installer's attention to Article 820-40 of the NEC that provides guidelines for proper grounding and, in particular, specifies that the cable ground shall be connected to the grounding system of the building, as close to the point of cable entry as practical.

### FCC INFORMATION

This equipment has been tested and found to comply with the limits for a Class B digital device, pursuant to Part 15 of the FCC Rules. These limits are designed to provide reasonable protection against harmful interference in a residential installation. This equipment generates, uses and can radiate radio frequency energy and, if not installed and used in accordance with the instructions, may cause harmful interference to radio communications. However, there is no guarantee that interference will not occur in a particular installation. If this equipment does cause harmful interference to radio or television reception, which can be determined by turning the equipment off and on, the user is encouraged to try to correct the interference by one or more of the following measures:

- Reorient or relocate the receiving antenna.
- Increase the separation between the equipment and receiver.
- Connect the equipment into an outlet on a circuit different from that to which the receiver is connected.
- Consult the dealer or an experienced radio/TV technician for help.

Caution : Any changes or modifications in construction of this device which are not expressly approved by the party responsible for compliance could void the user's authority to operate the equipment.

This Class B digital apparatus complies with Canadian ICES-003.

Cet appareil numérique de la Classe B est conforme à la norme NMB-003 du Canada.

### FOR YOUR SAFETY

U.S.A CANADA	120 V
-----------------	-------

Units shipped to the U.S.A and CANADA are designed for operation on 120 V AC only.  
 Safety precaution with use of a polarized AC plug.  
 However, some products may be supplied with a nonpolarized plug.

**CAUTION :** To prevent electric shock, match wide blade of plug to wide slot, fully insert.

**ATTENTION :** Pour éviter chocs électriques, introduire la lame la plus large de la fiche dans la borne correspondante de la prise et pousser jusqu' au fond.

### CAUTION

- Leave a space around the unit for sufficient ventilation.
- Avoid installation in extremely hot or cold locations, or in an area that is exposed to direct sunlight or heating equipment.
- Keep the unit free from moisture, water, and dust.
- Do not let foreign objects in the unit.
- The ventilation should not be impeded by covering the ventilation openings with items, such as newspapers, table-cloths, curtains, etc.
- No naked flame sources, such as lighted candles, should be placed on the unit.
- Please be care the environmental aspects of battery disposal.
- The unit shall not be exposed to dripping or splashing for use.
- No objects filled with liquids, such as vases, shall be placed on the unit.
- Do not let insecticides, benzene, and thinner come in contact with the set.
- Never disassemble or modify the unit in any way.
- Notes on the AC power cord and the wall outlet.
- The unit is not disconnected from the AC power source(mains) as long as it is connected to the wall outlet, even if the unit has been turned off.
- To completely disconnect this product from the mains, disconnect the plug from the wall socket outlet.
- When setting up this product, make sure that the AC outlet you are using is easily acceptable.
- Disconnect the plug from the wall outlet when not using the unit for long periods of time.



ENERGY STAR® is a U.S. registered mark. As an ENERGY STAR® Partner, Sherwood has determined that this product meets the ENERGY STAR® guidelines for energy efficiency.

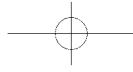



# CONTENTS

- IMPORTANT SAFETY INSTRUCTIONS ..... 3
- Introduction**
- READ THIS BEFORE OPERATING YOUR UNIT ..... 4
- System Connections** ..... 6
- Front Panel Controls** ..... 9
- Remote Controls** ..... 11
- REMOTE CONTROL OPERATION RANGE ..... 12
- LOADING BATTERIES ..... 12
- Operations**
- LISTENING TO A PROGRAM SOURCE ..... 13
- LISTENING TO RADIO BROADCASTS ..... 17
- RECORDING ..... 19
- OTHER FUNCTIONS ..... 19
- Troubleshooting Guide** ..... 20
- Specifications** ..... 21

ENGLISH

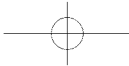



# System Connections

ENGLISH

- Do not plug the AC input cord into the wall AC outlet until all connections are completed.
- Be sure to observe the color coding when connecting audio, video and speaker cords.
- Make connections firmly and correctly. If not, it can cause loss of sound, noise or damage to the receiver.

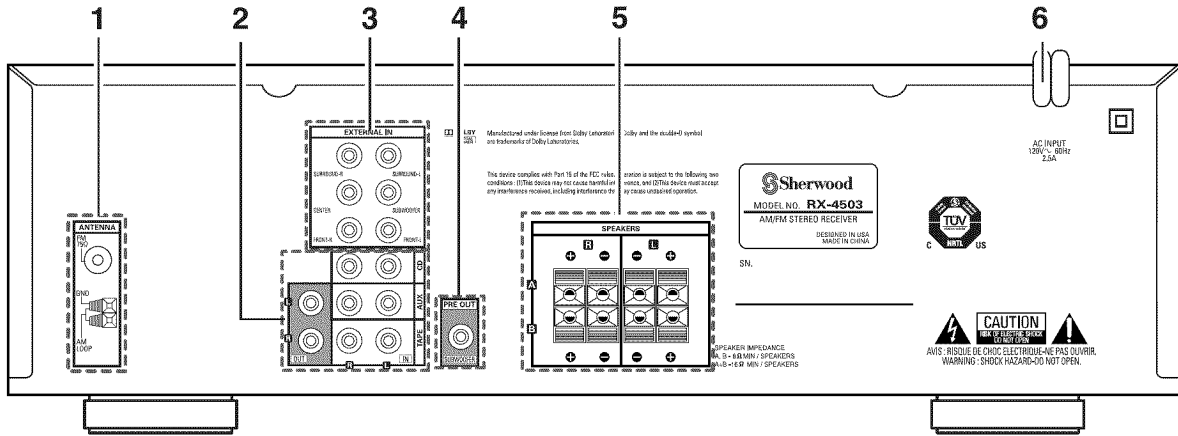

## 1. CONNECTING ANTENNAS

FM Indoor Antenna

FM Outdoor Antenna

- Change the position of the FM indoor antenna until you get the best reception of your favorite FM stations.
- A 75Ω outdoor FM antenna may be used to further improve the reception. Disconnect the indoor antenna before replacing it with the outdoor one.

AM Loop Antenna

AM Outdoor Antenna

- Place the AM loop antenna as far as possible from the receiver, TV set, speaker cords and the AC input cord and set it to a direction for the best reception.
- If the reception is poor with the AM loop antenna, an AM outdoor antenna can be used in place of the AM loop antenna.

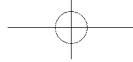



## 2. CONNECTING AUDIO COMPONENTS

- The TAPE IN/OUT jacks can be connected to audio recording equipment such as a tape deck, an MD recorder, etc.
- The AUX IN jacks can be connected to an additional components such as CD player, a tape deck, etc.

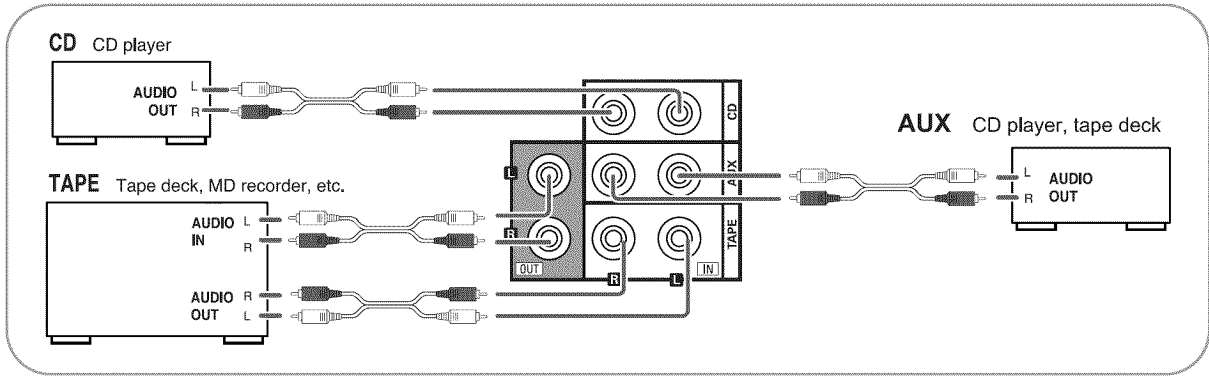

ENGLISH

## 3. CONNECTING EXTERNAL INs

- Use these jacks to connect the corresponding analog outputs of 6 CH decoder or DVD player with 6 CH output for Dolby Digital or DTS, etc.  
(For details, see the operator's manual of the component to be connected.)

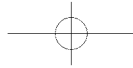
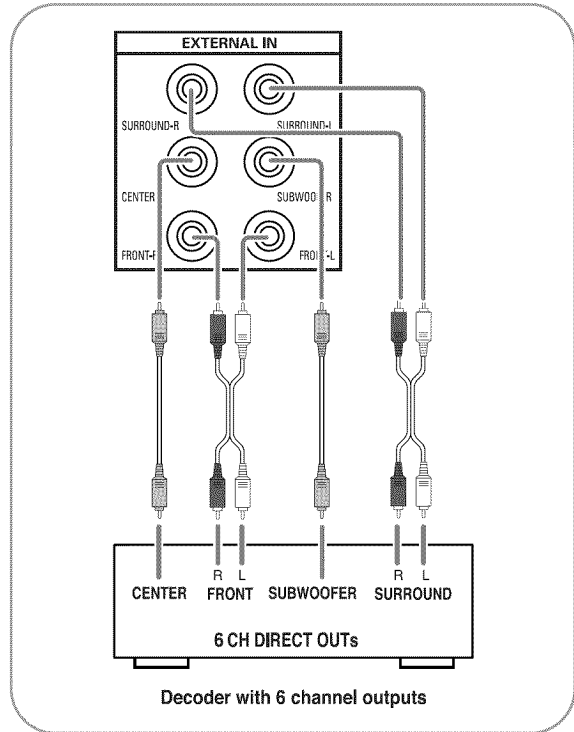

## 4. CONNECTING SUBWOOFER PRE OUT

- To emphasize the deep bass sounds, connect a powered subwoofer.

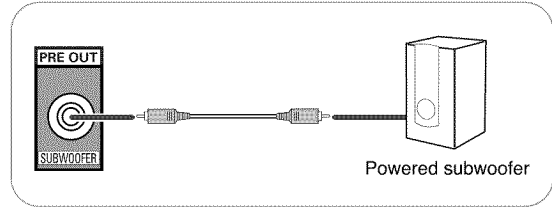

## 5. CONNECTING SPEAKERS

- Usually SPEAKER A terminals are used for only a pair of speakers. When you have another pair of speakers, SPEAKER B terminals can be used.
- Be sure to connect speakers firmly and correctly according to the channel(left and right) and the polarity(+ and -). If the connections are faulty, no sound will be heard from the speakers, and if the polarity of the speaker connection is incorrect, the sound will be unnatural and lack bass.

### ■ Notes :

- For safe amplifier operation, use the speakers with impedance of over  $8\Omega$  when you use only SPEAKER A or B terminals and use the speakers with impedance of over  $16\Omega$  when you use both SPEAKER A and B terminals.
- Do not let the bare speaker wires touch each other or any metal part of this unit. This could damage this unit and/or the speakers.

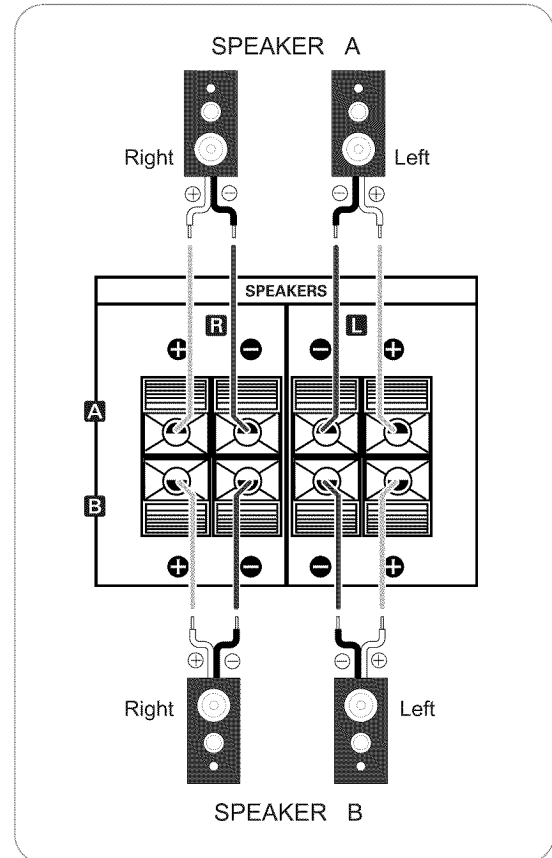

## 6. AC INPUT CORD

- Plug the cord into a wall AC outlet.



# Front Panel Controls

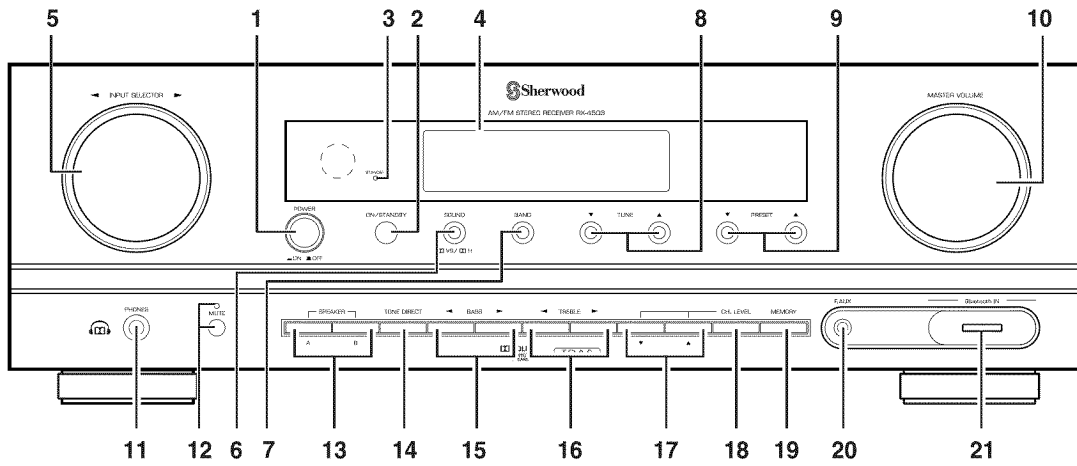

- |   |  |
|---|--|
| 1. POWER switch                                   | 12. MUTE button/indicator                            |
| 2. POWER ON/STANDBY button                        | 13. SPEAKER A, B SELECTRO buttons                    |
| 3. STANDBY indicator                              | 14. TONE DIRECT button                               |
| 4. FLUORESCENT DISPLAY<br>For details, see below. | 15. BASS UP/DOWN (▶/◀) buttons                       |
| 5. INPUT SELECTOR knob                            | 16. TREBLE UP/DOWN (▶/◀) buttons                     |
| 6. SOUND button                                   | 17. CHANNEL LEVEL UP/DOWN (▲/▼) buttons              |
| 7. BAND button                                    | 18. CHANNEL LEVEL button                             |
| 8. TUNING UP/DOWN (▲/▼) buttons                   | 19. MEMORY button                                    |
| 9. PRESET UP/DOWN (▲/▼) buttons                   | 20. FRONT AUX IN jack<br>For details, see next page. |
| 10. MASTER VOLUME CONTROL knob                    | 21. Bluetooth IN connector                           |
| 11. HEADPHONE jack                                |  |

## ■ FLUORESCENT DISPLAY

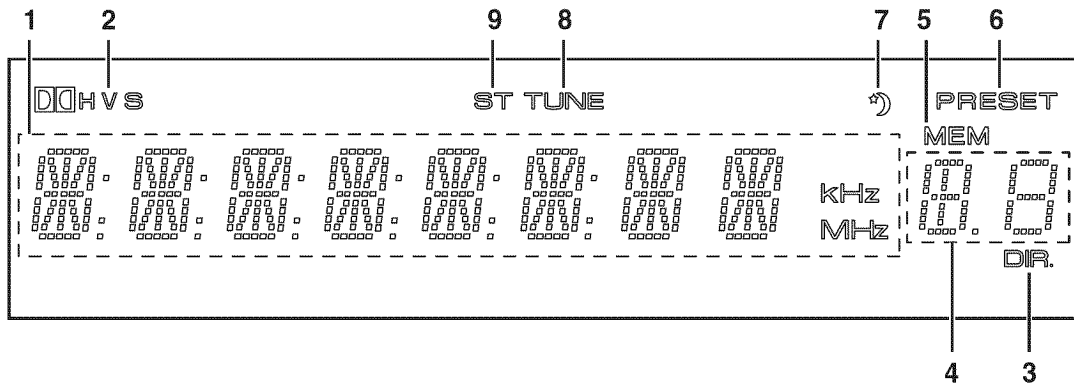

- |  |                     |
|--|---------------------|
| 1. Input, frequency, volume level, operating information, etc. | 6. PRESET indicator |
| 2. Sound mode indicators                                       | 7. SLEEP indicator  |
| 3. DIRECT indicator  | 8. TUNED indicator  |
| 4. Preset number, sleep time display                           | 9. STEREO indicator |
| 5. MEMORY indicator  |                     |

ENGLISH

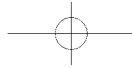





ENGLISH

■ FRONT AUX IN JACK

- The FRONT AUX IN jack can be connected to additional audio components such as an MP3 player, etc.
- Notes :
  - When connecting this jack to an MP3 player, etc., you should use the stereo mini cord, not a mono mini cord.
  - When not using the FRONT AUX IN jack and the Bluetooth IN connector, cover these with the supplied cap.

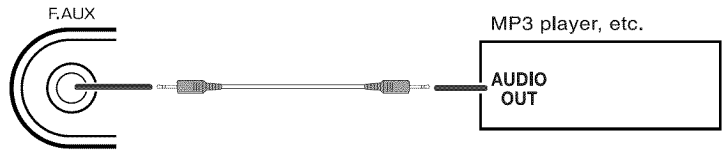

■ Bluetooth IN CONNECTOR

- If the **Bluetooth IN** connector is connected to Sherwood Audio Receiver BT-R7(sold separately) with *Bluetooth* wireless technology, you can enjoy music wirelessly with a music player featuring *Bluetooth* wireless technology such as MP3 player, mobile phone, etc.. (For information on Sherwood Audio Receiver BT-R7, contact your dealer.)
- The *Bluetooth* word mark and logos are registered trademarks owned by Bluetooth SIG, Inc. and any use of such marks by Sherwood Corporation is under license. Other trademarks and trade names are those of their respective owners.

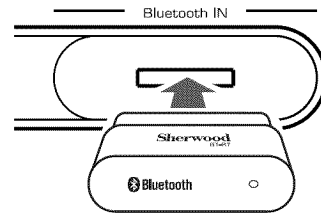

- Note :
  - For safe operation, turn the power off before connecting or disconnecting the Audio Receiver BT-R7.

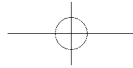

# Remote Controls

ENGLISH

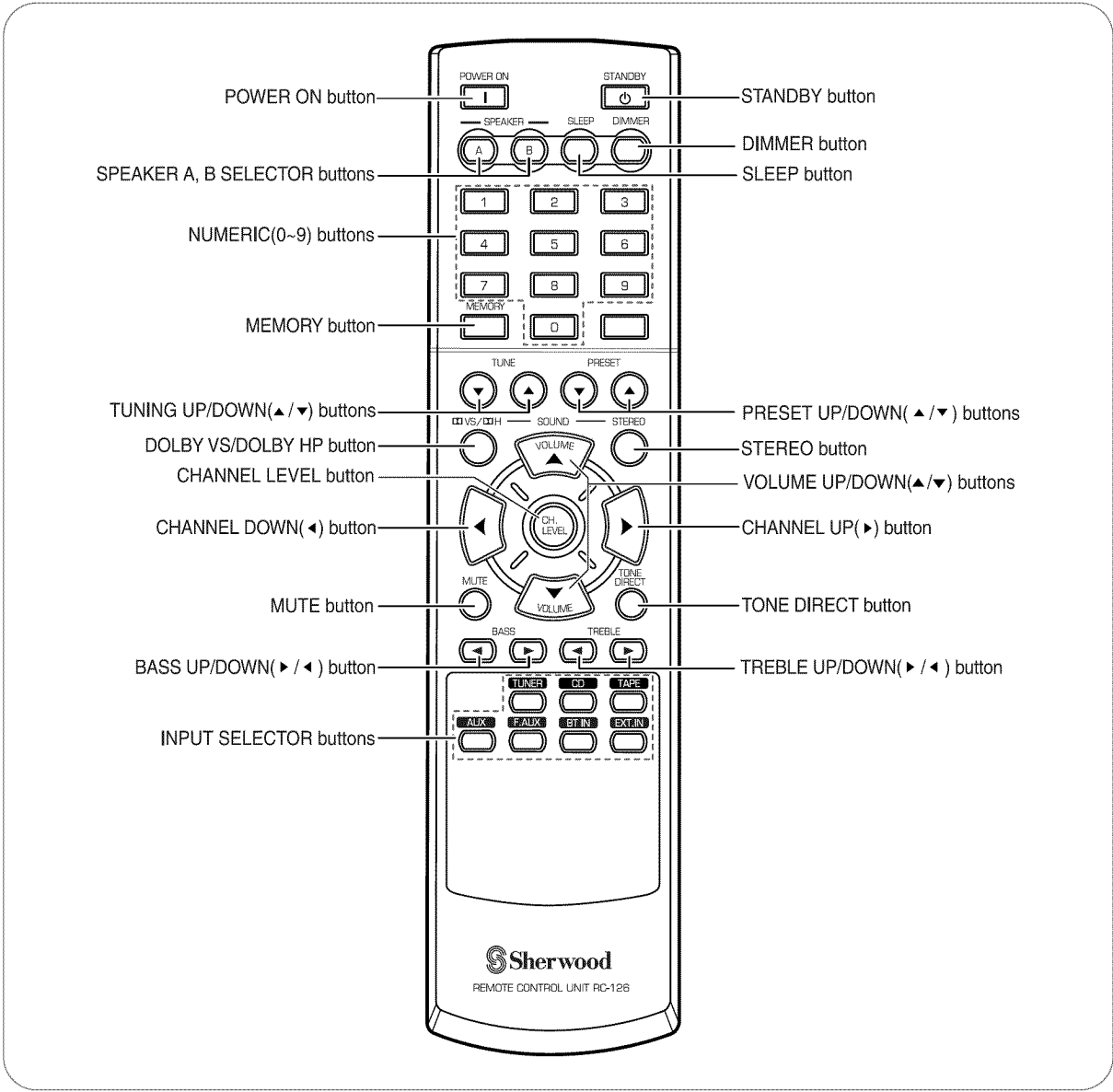

## REMOTE CONTROL OPERATION RANGE

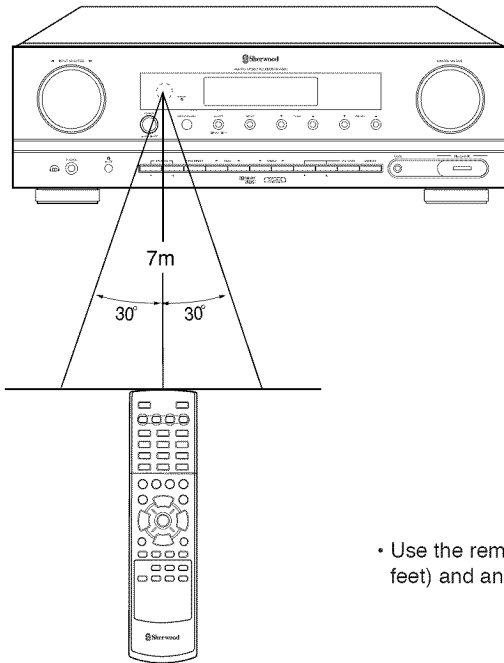

- Use the remote control unit within a range of about 7 meters (23 feet) and angles of up to 30 degrees aiming at the remote sensor.

## LOADING BATTERIES

1. Remove the cover.

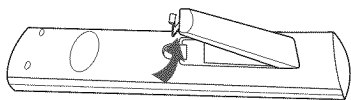

2. Load two batteries ("AAA" size, 1.5 V) matching the polarity.

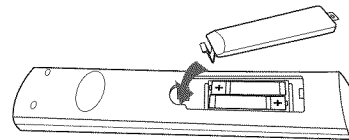

- Remove the batteries when they are not used for a long time.
- Do not use the rechargeable batteries (Ni-Cd type).

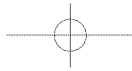

# Operations

## LISTENING TO A PROGRAM SOURCE

### Before operation

- Push the POWER switch.

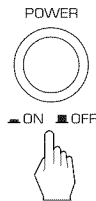

- This unit enters the standby mode and the STANDBY indicator lights up. This means that the receiver is not disconnected from the AC mains and a small amount of current is retained to support the operation readiness.
- To switch the power off, push the POWER switch again. Then the power is cut off and the STANDBY indicator goes off.

### 1. In the standby mode, turn the power on.

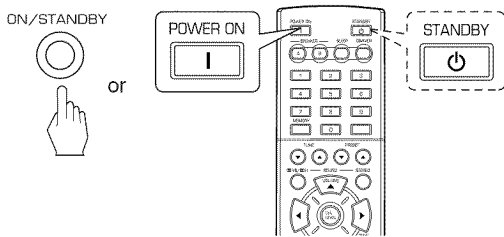

- Each time the POWER ON/STANDBY button on the front panel is pressed, the receiver is turned on to enter the operating mode or off to enter the standby mode.
- On the remote control, press the POWER ON button to enter the operating mode or press the STANDBY button to enter the standby mode.
- In the standby mode, if the INPUT SELECTOR button on the remote control is pressed, the receiver is turned on automatically and the desired input is selected.

### 2. Switch the desired speakers on.

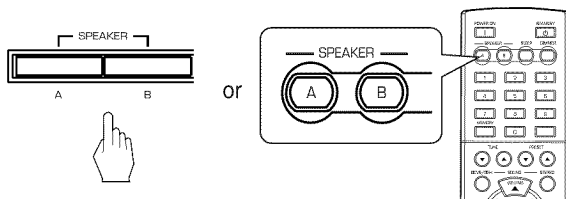

- Then the corresponding speaker indication ("SPK A or B") is displayed and the sound can be heard from the speakers connected to the selected speaker terminals.
- When using the headphones for private listening, press the corresponding SPEAKER button to switch off both A and B speakers.

### 3. Select the desired input source.

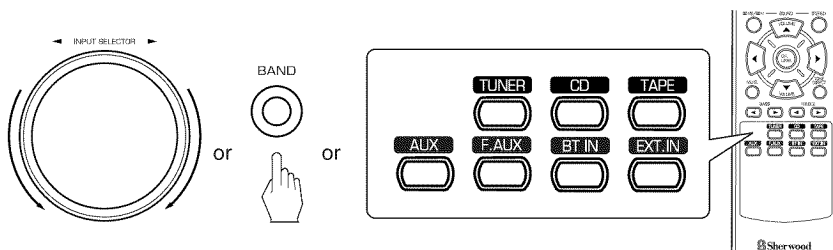

- Each time the INPUT SELECTOR knob is rotated, the input source changes as follows :

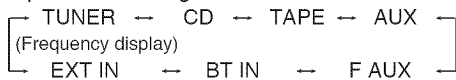

- Each time the BAND button or the TUNER button is pressed, the band changes as follows:

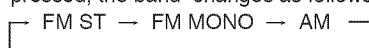

- When selecting the EXTERNAL IN, 6 separate analog signals from the component connected to this input pass through the tone and volume circuits only and can be heard from your speakers.
- These analog signals can be heard only, not recorded.

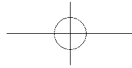



4. Operate the selected component for playback.

---

ENGLISH

5. Adjust the (overall) volume.

---

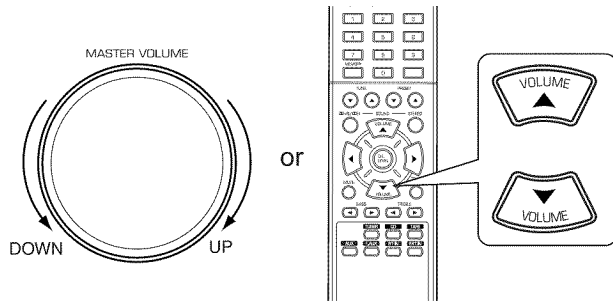

6. To mute the sound.

---

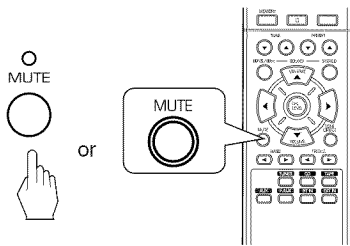

- Then the MUTE indicator will flicker.
- To resume the previous sound level, press it again.

7. To listen with the headphones.

---

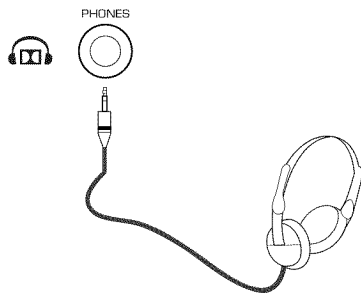

- Be sure to switch off both A and B speakers.
- Note :**
- Be careful not to set the volume too high when using headphones.

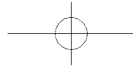

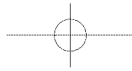

### Selecting a surround sound mode

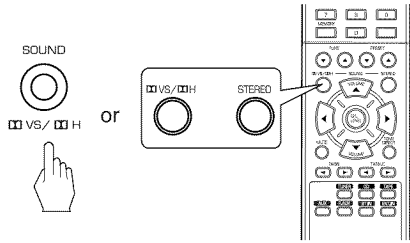

- Each time this button is pressed, the mode changes as follows :

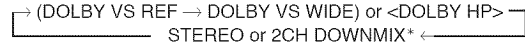

- ( ) : Possible only when listening via the speakers.
- < > : Possible only when listening via the headphones.
- \* : Possible only when selecting the EXTERNAL IN as an input source.

- On the remote control, press the " VS/□H " button or the STEREO button depending on whether listening in a surround mode or in the stereo mode.

ENGLISH

#### ■ Surround sound modes

- Dolby Virtual Speaker

This mode creates a virtual surround sound field using as few as two front speakers and subwoofer, allowing you to experience listening from 5.1 channel speakers.

\* Dolby Virtual Speaker Reference("DOLBY VS REF")

The width of the front sound image is defined by the actual distance between front speakers.

\* Dolby Virtual Speaker Wide("DOLBY VS WIDE")

The width of the front sound image seems to extend beyond the front speakers.

- Dolby Headphone("DOLBY HP")

This mode simulates 5.1 channel surround sound, which allows you to enjoy 5.1 channel surround sound through 2 channel headphones, just like listening from 5.1 channel speakers.

Dolby and the double-D symbol are registered trademarks of Dolby Laboratories.

#### ■ 2CH downmix mode

- This mode allows the multi-channel signals from the EXTERNAL INs to be mixed down into two front channels and to be reproduced through front speakers or headphones.

### Adjusting the channel level

1. Select the desired channel.

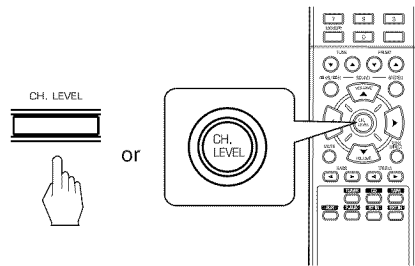

- Each time this button is pressed, the channel is selected as follows:



- ( ) : Possible only when listening via the speakers.
- When the channel display disappears, press this button again.

2. At each channel, adjust the level as desired.

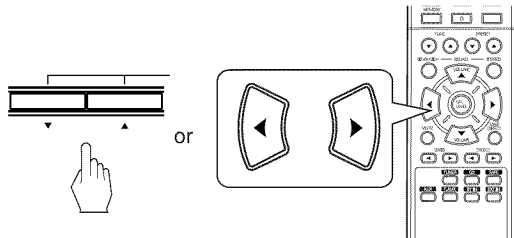

- The channel levels can be adjusted within the range of -15 ~ +15 dB.
- In general, we recommend the level to be adjusted to 0 dB.

3. Repeat the above steps 1 and 2 to adjust each channel level.

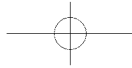



## Adjusting the tone (bass and treble)

### 1. Select the desired tone mode.

ENGLISH

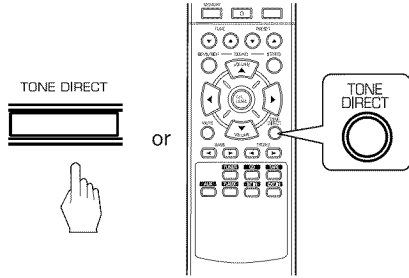

• Each time this button is pressed, the tone mode is selected as follows :

OFF : To listen to a program source without the tone effect.  
↓ ("DIR" indicator lights up.)

ON : To adjust the tone for your taste.  
("DIR" indicator goes off.)

■ **Note :**

• When the EXTERNAL IN is selected as an input source, the TONE cannot be set to ON.

■ **When the TONE is set to ON to adjust the tone (bass and treble).**

### 2. Adjust the tone (treble and bass) as desired.

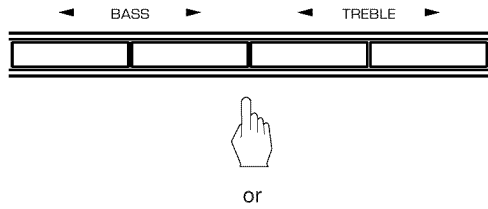

• The tone level can be adjusted within the range of -12 ~ +12.

■ **Notes :**

• Extreme settings at high volume may damage your speakers.  
• In general, the bass and treble levels are adjusted to 0.

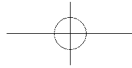
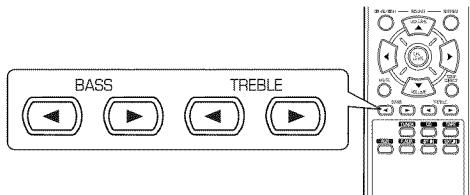



# LISTENING TO RADIO BROADCASTS

## Auto tuning

1. Select the desired band.

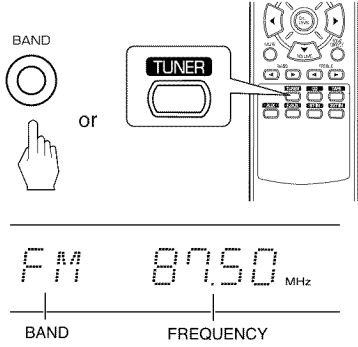

• Each time this button is pressed, the band changes as follows ;

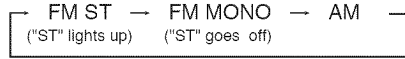

• When FM stereo broadcasts are poor because of weak broadcast signals, select the FM mono mode to reduce the noise, then FM broadcasts are reproduced in monaural sound.

2. Press the TUNING UP/DOWN buttons for more than 0.5 second.

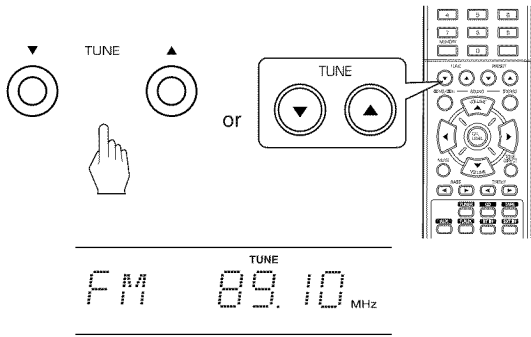

- The tuner will now search until a station of sufficient strength has been found. The display shows the tuned frequency and "TUNE".
- If the station found is not the desired one, simply repeat this operation.
- Weak stations are skipped during auto tuning.

## Manual tuning

- Manual tuning is useful when you already know the frequency of the desired station.
- After selecting the desired band, press the TUNING UP/ DOWN buttons repeatedly until the right frequency has been reached.

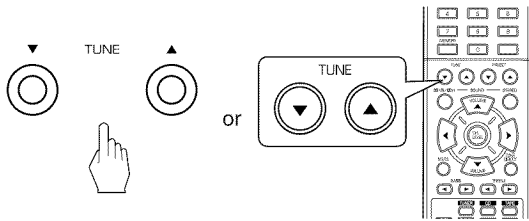

## Auto presetting

- Auto presetting function automatically searches for FM stations only and store them in the memory.
- While listening to FM radio broadcasts, press and hold down the MEMORY button for more than 2 seconds.

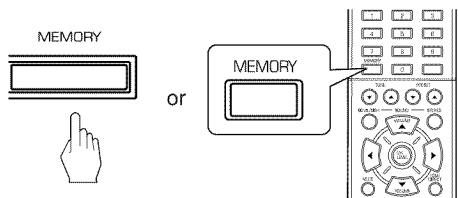

- Then "AUTO MEM" flickers and this receiver starts auto presetting.
- To stop auto presetting, press this button again.
- Up to 30 FM stations can be stored.

■ Notes:

- FM stations of weak strength cannot be memorized.
- To memorize AM stations or weak stations, preform "Manual presetting" procedure with using "Manual tuning" operation.

ENGLISH

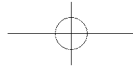





ENGLISH

**Manual presetting**

- You can store up to 30 preferred stations in the memory.

**1.** Tune in the desired station with auto or manual tuning.

**2.** Press the MEMORY button.

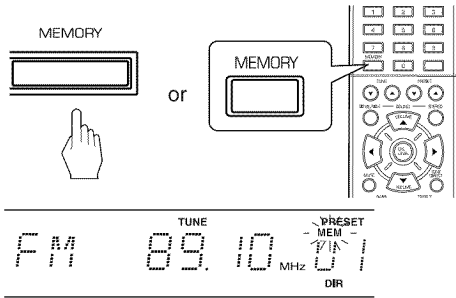

- "MEM" is flickering for several seconds.

**3.** Select the desired preset number (1~30) and press the MEMORY button.

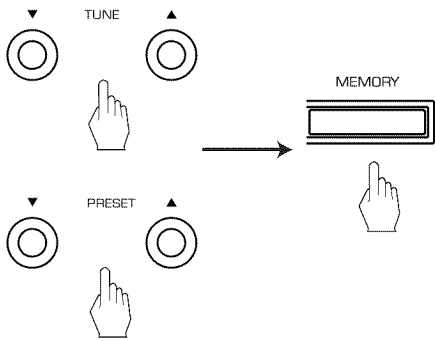

- When using the NUMERIC buttons on the remote control.

Examples) For "3" :   
 For "15" :  within 2 seconds   
 For "30" :  within 2 seconds

- The station has now been stored in the memory.
- When using the NUMERIC buttons, the station is stored automatically without pressing the MEMORY button.
- A stored frequency is erased from the memory by storing another frequency in its place.
- If "MEM" goes off, start again from the above step 2.

**4.** Repeat the above steps 1 to 3 to memorize other stations.

**MEMORY BACKUP FUNCTION**

The following items, set before the receiver is turned off, are memorized.

- INPUT SELECTOR settings
- Surround mode settings
- Preset stations, etc.

**Tuning to preset stations**

- After selecting the tuner as an input source, select the desired preset number.

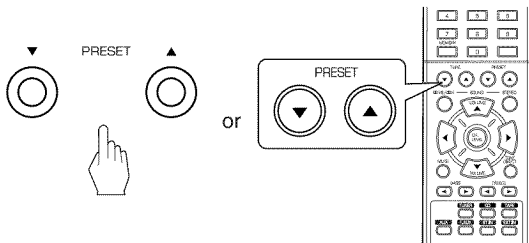

- When using the NUMERIC buttons on the remote control.

Examples) For "3" :   
 For "15" :  within 2 seconds   
 For "30" :  within 2 seconds

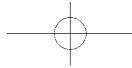



## RECORDING

- The analog signals from the EXTERNAL INs can be heard but cannot be recorded.
- The volume and tone (bass, treble) settings have no effect on the recording signals.

### Recording with TAPE

1. Select the desired input as a recording source except for TAPE.

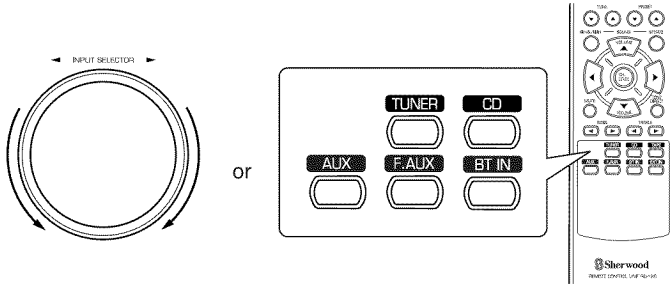

2. Start recording on the TAPE.

3. Start play on the desired input.

## OTHER FUNCTIONS

### Operating the sleep timer

- The sleep timer allows the system to continue to operate for a specified period of time before automatically shutting off.
- To set the receiver to automatically turn off after the specified period of time.

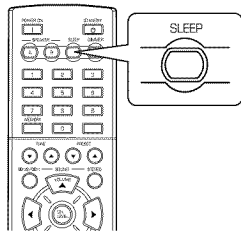

- Each time this button is pressed, the sleep time changes as follows:

10 → 20 → 30 → --- → 90 → OFF  
Unit : minutes

- While operating the sleep timer, " ⌘ " lights up.
- When the sleep time is selected, the fluorescent display is dimly lit.

### Adjusting the brightness of the fluorescent display

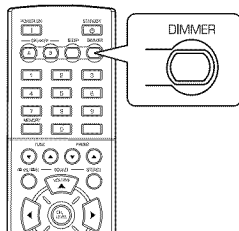

- Each time this button is pressed, the brightness of the fluorescent display changes as follows:

ON → dimmer → OFF

- In the display OFF mode, pressing any button will restore the display ON mode.

ENGLISH

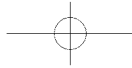

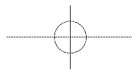

## Troubleshooting Guide

If a fault occurs, run through the table below before taking your receiver for repair. If the fault persists, attempt to solve it by switching the receiver off and on again. If this fails to resolve the situation, consult with your dealer. Under no circumstances should you repair the receiver yourself as this could invalidate the warranty.

ENGLISH

PROBLEM	POSSIBLE CAUSE	REMEDY
No power	<ul style="list-style-type: none"> <li>The AC input cord is disconnected.</li> <li>Poor connection at AC wall outlet or the outlet is inactive.</li> </ul>	<ul style="list-style-type: none"> <li>Connect the cord securely.</li> <li>Check the outlet using a lamp or another appliance.</li> </ul>
No sound	<ul style="list-style-type: none"> <li>The speaker cords are disconnected.</li> <li>The volume is adjusted too low.</li> <li>The MUTE button is pressed to ON.</li> <li>Speakers are not switched on.</li> <li>Incorrect selection of the input source.</li> <li>Incorrect connections between the components.</li> </ul>	<ul style="list-style-type: none"> <li>Check the speaker connections.</li> <li>Adjust the volume.</li> <li>Press the MUTE button to cancel the muting effect.</li> <li>Press the SPEAKER A or B button to ON.</li> <li>Select the desired input source correctly.</li> <li>Make connections correctly.</li> </ul>
Stations cannot be received	<ul style="list-style-type: none"> <li>No antenna is connected.</li> <li>The desired station frequency is not tuned in.</li> <li>The antenna is in wrong position.</li> </ul>	<ul style="list-style-type: none"> <li>Connect an antenna.</li> <li>Tune in the desired station frequency.</li> <li>Move the antenna and retry tuning.</li> </ul>
Preset stations cannot be received	<ul style="list-style-type: none"> <li>An incorrect station frequency has been memorized.</li> <li>The memorized stations are cleared.</li> </ul>	<ul style="list-style-type: none"> <li>Memorize the correct station frequency.</li> <li>Memorize the stations again.</li> </ul>
Poor FM reception	<ul style="list-style-type: none"> <li>No antenna is connected.</li> <li>The antenna is not positioned for the best reception.</li> </ul>	<ul style="list-style-type: none"> <li>Connect an antenna.</li> <li>Change the position of the antenna.</li> </ul>
Continuous hissing noise during FM reception, especially when a stereo broadcast is received.	<ul style="list-style-type: none"> <li>Weak signals.</li> </ul>	<ul style="list-style-type: none"> <li>Change the position of the antenna.</li> <li>Install an outdoor antenna.</li> </ul>
Continuous or intermittent hissing noise during AM reception, especially at night.	<ul style="list-style-type: none"> <li>Noise is caused by motors, fluorescent lamps or lightning, etc.</li> </ul>	<ul style="list-style-type: none"> <li>Keep the receiver away from noise sources.</li> <li>Install an outdoor AM antenna.</li> </ul>
No recording	<ul style="list-style-type: none"> <li>Incorrect selection between the components.</li> <li>Incorrect operation of each component for playback and recording.</li> </ul>	<ul style="list-style-type: none"> <li>Make connections correctly.</li> <li>Operate each component correctly.</li> </ul>
Remote control unit does not operate.	<ul style="list-style-type: none"> <li>Batteries are not loaded or exhausted.</li> <li>The remote sensor is obstructed.</li> </ul>	<ul style="list-style-type: none"> <li>Replace the batteries.</li> <li>Remove the obstacle.</li> </ul>

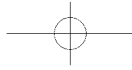

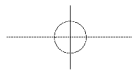

## Specifications

### ■ AMPLIFIER SECTION

- Power output, stereo mode, 8 Ω, THD 0.08 %, 40 Hz~20 kHz ..... 2X100 W
- Total harmonic distortion, 8 Ω, 100 W, 40 Hz~20 kHz ..... 0.02 %
- Intermodulation distortion  
60 Hz : 7 kHz= 4 : 1 SMPTE, 8 Ω, 100 W ..... 0.02 %
- Input sensitivity, 47 kΩ  
Line(CD,TAPE,AUX) ..... 200 mV
- Signal to noise ratio, IHF "A" weighted  
Line(CD,TAPE,AUX) ..... 96 dB
- Frequency response  
Line(CD,TAPE,AUX), 10 Hz~95 kHz ..... -3 dB
- Output level  
TAPE OUT, 2.2 kΩ ..... 200 mV
- Bass/Treble control, 100 Hz/10 kHz ..... ±12 dB

### ■ FM TUNER SECTION

- Tuning frequency range ..... 87.5~108 MHz
- Usable sensitivity, THD 3%, S/N 30 dB ..... 16.25 dBf
- 50 dB quieting sensitivity, mono/stereo ..... 25.2/45.2 dBf
- Signal to noise ratio, 65 dBf, mono/stereo ..... 67/66 dB
- Total harmonic distortion, 65 dBf, 1 kHz, mono/stereo ..... 0.6/0.7%
- Frequency response, 20 Hz~14 kHz ..... -3 dB
- Stereo separation, 1 kHz ..... 35 dB
- Capture ratio ..... 4 dB
- IF rejection ratio ..... 105 dB

### ■ AM TUNER SECTION

- Tuning frequency range ..... 520~1710 kHz
- Usable sensitivity ..... 800 μV/m
- Signal to noise ratio ..... 51 dB
- Selectivity ..... 30 dB

### ■ GENERAL

- Power supply ..... 120 V~ 60 Hz
- Power consumption ..... 2.5A
- Dimensions (W×H×D, including protruding parts) ..... 440×141×365mm(17-3/8×5-1/2×14-3/8 inches)
- Weight (Net) ..... 8.3 kg(18.3 lbs)

Note: Design and specifications are subject to change without notice for improvements.

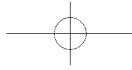



**RX-4503**  
AM/FM STEREO RECEIVER

