

SEARS

CRAFTSMAN®

MODEL NUMBER 917.256501 OWNER'S MANUAL

- Assembly
- Operation
- Customer Responsibilities
- Service and Adjustments
- Repair Parts

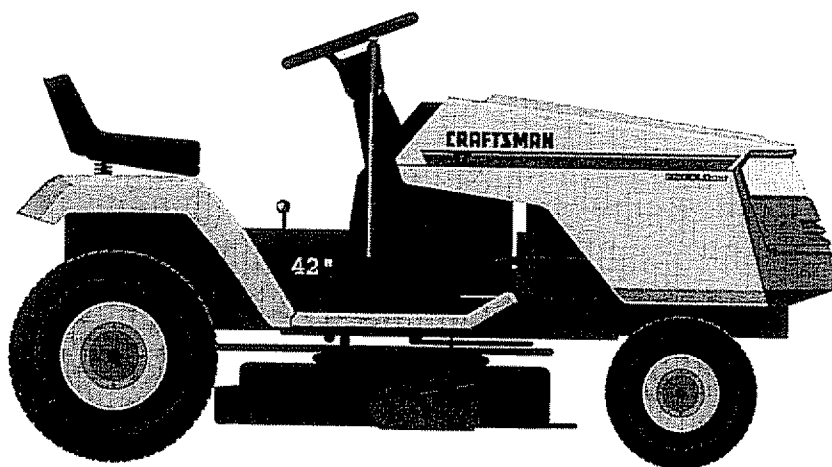

CAUTION: Read and follow all safety rules and instructions before operating this equipment.
FOR CONSUMER ASSISTANCE HOT LINE, CALL THIS TOLL FREE NUMBER: 1-800-659-5917

Sears, Roebuck and Co., Hoffman Estates, IL 60179 U.S.A.



SAFETY RULES



Safe Operation Practices for Ride-On Mowers

IMPORTANT: THIS CUTTING MACHINE IS CAPABLE OF AMPUTATING HANDS AND FEET AND THROWING OBJECTS. FAILURE TO OBSERVE THE FOLLOWING SAFETY INSTRUCTIONS COULD RESULT IN SERIOUS INJURY OR DEATH.

I. GENERAL OPERATION

- Read, understand, and follow all instructions in the manual and on the machine before starting.
- Only allow responsible adults, who are familiar with the instructions, to operate the machine.
- Clear the area of objects such as rocks, toys, wire, etc., which could be picked up and thrown by the blade.
- Be sure the area is clear of other people before mowing. Stop machine if anyone enters the area.
- Never carry passengers.
- Do not mow in reverse unless absolutely necessary. Always look down and behind before and while backing.
- Be aware of the mower discharge direction and do not point it at anyone. Do not operate the mower without either the entire grass catcher or the guard in place.
- Slow down before turning.
- Never leave a running machine unattended. Always turn off blades, set parking brake, stop engine, and remove keys before dismounting.
- Turn off blades when not mowing.
- Stop engine before removing grass catcher or unclogging chute.
- Mow only in daylight or good artificial light.
- Do not operate the machine while under the influence of alcohol or drugs.
- Watch for traffic when operating near or crossing roadways.
- Use extra care when loading or unloading the machine into a trailer or truck.

II. SLOPE OPERATION

Slopes are a major factor related to loss-of-control and tipover accidents, which can result in severe injury or death. All slopes require extra caution. If you cannot back up the slope or if you feel uneasy on it, do not mow it.

DO:

- Mow up and down slopes, not across.
- Remove obstacles such as rocks, tree limbs, etc.
- Watch for holes, ruts, or bumps. Uneven terrain could overturn the machine. *Tall grass can hide obstacles.*
- Use slow speed. Choose a low gear so that you will not have to stop or shift while on the slope.
- Follow the manufacturer's recommendations for wheel weights or counterweights to improve stability.
- Use extra care with grass catchers or other attachments. These can change the stability of the machine.
- Keep all movement on the slopes *slow* and *gradual*. Do not make sudden changes in speed or direction.
- Avoid starting or stopping on a slope. If tires lose traction, disengage the blades and proceed slowly *straight* down the slope.

DO NOT:

- Do not turn on slopes unless necessary, and then, turn slowly and gradually downhill, if possible.
- Do not mow near drop-offs, ditches, or embankments. The mower could suddenly turn over if a wheel is over the edge of a cliff or ditch, or if an edge caves in.
- Do not mow on wet grass. Reduced traction could cause sliding.
- Do not try to stabilize the machine by putting your foot on the ground.
- Do not use grass catcher on steep slopes.

III. CHILDREN

Tragic accidents can occur if the operator is not alert to the presence of children. Children are often attracted to the machine and the mowing activity. *Never* assume that children will remain where you last saw them.

- Keep children out of the mowing area and under the watchful care of another responsible adult.
- Be alert and turn machine off if children enter the area.
- Before and when backing, look behind and *down* for small children.
- Never carry children. They may fall off and be seriously injured or interfere with safe machine operation.
- Never allow children to operate the machine.
- Use extra care when approaching blind corners, shrubs, trees, or other objects that may obscure vision.

IV. SERVICE

- Use extra care in handling gasoline and other fuels. They are flammable and vapors are explosive.
 - Use only an approved container.
 - Never remove gas cap or add fuel with the engine running. Allow engine to cool before refueling. Do not smoke.
 - Never refuel the machine indoors.
 - Never store the machine or fuel container inside where there is an open flame, such as a water heater.
- Never run a machine inside a closed area
- Keep nuts and bolts, especially blade attachment bolts, tight and keep equipment in good condition.
- Never tamper with safety devices. Check their proper operation regularly.
- Keep machine free of grass, leaves, or other debris build-up. Clean oil or fuel spillage. Allow machine to cool before storing.
- Stop and inspect the equipment if you strike an object. Repair, if necessary, before restarting.
- Never make adjustments or repairs with the engine running.
- Grass catcher components are subject to wear, damage, and deterioration, which could expose moving parts or allow objects to be thrown. Frequently check components and replace with manufacturer's recommended parts, when necessary.
- Mower blades are sharp and can cut. Wrap the blade(s) or wear gloves, and use extra caution when servicing them.
- Check brake operation frequently. Adjust and service as required.



Look for this symbol to point out important safety precautions. It means CAUTION!!! BECOME ALERT!!! YOUR SAFETY IS INVOLVED.



CAUTION: Always disconnect spark plug wire and place wire where it cannot contact spark plug in order to prevent accidental starting when setting up, transporting, adjusting or making repairs.

WARNING

The engine exhaust from this product contains chemicals known to the State of California to cause cancer, birth defects, or other reproductive harm.

CONGRATULATIONS on your purchase of a Sears Tractor. It has been designed, engineered and manufactured to give you the best possible dependability and performance.

Should you experience any problem you cannot easily remedy, please contact your nearest Sears Authorized Service Center/Department. We have competent, well-trained technicians and the proper tools to service or repair this tractor.

Please read and retain this manual. The instructions will enable you to assemble and maintain your unit properly. Always observe the "SAFETY RULES".

MODEL NUMBER	917.256501
SERIAL NUMBER	_____
DATE OF PURCHASE	_____
THE MODEL AND SERIAL NUMBERS WILL BE FOUND ON A PLATE UNDER THE SEAT.	
YOU SHOULD RECORD BOTH SERIAL NUMBER AND DATE OF PURCHASE AND KEEP IN A SAFE PLACE FOR FUTURE REFERENCE.	

MAINTENANCE AGREEMENT

A Sears Maintenance Agreement is available on this product. Contact your nearest Sears store for details.

CUSTOMER RESPONSIBILITIES

- Read and observe the safety rules.
- Follow a regular schedule in maintaining, caring for and using your tractor.
- Follow the instructions under "Customer Responsibilities" and "Storage" sections of this owner's manual.

WARNING: This tractor is equipped with an internal combustion engine and should not be used on or near any unimproved forest-covered, brush-covered or grass-covered land unless the engine's exhaust system is equipped

PRODUCT SPECIFICATIONS

HORSEPOWER:	13.5
GASOLINE CAPACITY AND TYPE:	5 QUARTS UNLEADED REGULAR
OIL TYPE (API-SF/SG):	SAE 30 (above 32°F) SAE 5W-30 (below 32°F)
OIL CAPACITY:	3 PINTS
SPARK PLUG: (GAP: .030")	CHAMPION RJ19LM STD361458
VALVE CLEARANCE:	INTAKE: .005" - .007" EXHAUST: .009" - .011"
GROUND SPEED (MPH):	FORWARD: 1st 1.0 2nd 1.3 3rd 2.1 4th 3.1 5th 4.0 6th 5.1 REVERSE: 1.6
TIRE PRESSURE:	FRONT: 14 PSI REAR: 12 PSI
CHARGING SYSTEM:	3 AMPS BATTERY 5 AMPS HEADLIGHTS
BATTERY:	AMP/HR: 25 MIN CCA: 190 CASE SIZE: U1R
BLADE BOLT TORQUE:	30-35 FT. LBS.

with a spark arrester meeting applicable local or state laws (if any). If a spark arrester is used, it should be maintained in effective working order by the operator.

In the state of California the above is required by law (Section 4442 of the California Public Resources Code). Other states may have similar laws. Federal laws apply on federal lands. A spark arrester for the muffler is available through your nearest Sears Authorized Service Center/Department (See REPAIR PARTS section of this manual).

LIMITED TWO YEAR WARRANTY ON CRAFTSMAN RIDING EQUIPMENT

For two (2) years from the date of purchase, if this Craftsman Riding Equipment is maintained, lubricated and tuned up according to the instructions in the owner's manual, Sears will repair or replace, free of charge, any parts found to be defective in material or workmanship.

This Warranty does not cover:

- Expendable items which become worn during normal use, such as blades, spark plugs, air cleaners, belts, etc.
- Tire replacement or repair caused by punctures from outside objects, such as nails, thorns, stumps, or glass.
- Repairs necessary because of operator abuse, negligence, improper storage or accident or the failure to maintain the equipment according to the instructions contained in the owner's manual.
- Riding equipment used for commercial or rental purposes.

LIMITED 90 DAY WARRANTY ON BATTERY

For ninety (90) days from date of purchase, if any battery included with this riding equipment proves defective in material workmanship and our testing determines the battery will not hold a charge, Sears will replace the battery at no charge.

IN-HOME WARRANTY SERVICE ON YOUR CRAFTSMAN RIDING EQUIPMENT IS AVAILABLE AT NO-CHARGE FOR 30 DAYS FROM THE DATE OF PURCHASE. PLEASE CONTACT YOUR NEAREST SERVICE CENTER. AFTER 30 DAYS FROM THE DATE OF PURCHASE, WARRANTY SERVICE IS AVAILABLE BY TAKING YOUR CRAFTSMAN RIDING EQUIPMENT TO YOUR NEAREST SEARS SERVICE CENTER. (IN-HOME WARRANTY SERVICE WILL STILL BE AVAILABLE AFTER 30 DAYS FROM THE DATE OF PURCHASE BUT A STANDARD TRIP CHARGE WILL APPLY.) THIS WARRANTY APPLIES ONLY WHILE THIS PRODUCT IS IN THE UNITED STATES.

This Warranty gives you specific legal rights, and you may also have other rights which may vary from state to state.

SEARS, ROEBUCK AND CO., D/817 WA, HOFFMAN ESTATES, IL 60179

TABLE OF CONTENTS

SAFETY RULES	2	MAINTENANCE SCHEDULE	15
PRODUCT SPECIFICATIONS	3	SERVICE AND ADJUSTMENTS	19-24
CUSTOMER RESPONSIBILITIES	3, 15-18	STORAGE	25
WARRANTY	3	TROUBLESHOOTING	26-27
TRACTOR ACCESSORIES	5	REPAIR PARTS - TRACTOR	30-47
ASSEMBLY	7-9	REPAIR PARTS - ENGINE	48-52
OPERATION	10-14	PARTS ORDERING/SERVICE	BACK COVER





INDEX

A		E		O	
Accessories	5	Electrical:		Oil:	
Adjustments:		Interlocks and Relays	23	Cold Weather Conditions	13,17
Brake	21	Schematic	29	Engine	17
Carburetor	24	Wiring Diagram	30	Storage	25
Mower		Engine:		Operation	10-14
Front-To-Back	20	Air Filter	17-18	Operating Mower	13
Side-To-Side	20	Air Screen	18	Options:	
Throttle Control Cable	24	Cooling Fins	18	Accessories	5
Air Filter, Engine	17-18	Oil Change	17	Spark Arrester	3,40
Air Screen, Engine	18	Oil Level	13		
Assembly	7-9	Oil Type	13,17	P	
		Preparation	13	Parking Brake	11,12
		Repair Parts	48-52	Parts Bag	6
		Starting	14	Parts, Replacement/Repair	30-47
		Storage	25	Product Specifications	3
B		F		R	
Battery:		Filter:		Repair Parts	30-47
Charging	8	Air Filter	17		
Cleaning	17	Fuel	18	S	
Installation	9	Fuel:		Safety Rules	2
Levels	8,16	Type	14	Seat	8
Preparation	8	Storage	25	Service and Adjustments	19-24
Starting with Weak Battery	22	Fuse	23	Carburetor	24
Storage	25			Fuse	23
Terminals	17	H		Hood Removal/Installation	23
Belt:		Hood Removal/Installation	23	Motion Drive Belt	
Motion Drive				Removal/Replacement	21
Removal/Replacement	21	L		Mower Belt(s)	
Mower Belt(s)		Leveling Mower Deck	20	Removal/Replacement	21
Removal/Replacement	21	Lubrication:		Mower Adjustment	
Blade:		Chart	15	Front-to-Back	20
Sharpening	16	Engine	17	Side-to-Side	20
Replacement	16	M		Mower Removal/Installation	19
Brake Adjustment	21	Maintenance Schedule	15	Tire Care	8,16,22
		Mower:		Slope Guide Sheet	55
C		Adjustment, Front-to-Back	20	Spark Plug(s)	18
Carburetor Adjustment	24	Adjustment, Side-to-Side	20	Specifications	3
Controls, Tractor	11	Blade Replacement	16	Starting the Engine	13-14
Customer Responsibilities	16-18	Blade Sharpening	16	Steering Wheel	7,22
Engine:		Cutting Height	12	Stopping the Tractor	12
Air Filter	17	Installation	19	Storage	25
Air Screen	18	Operation	13		
Cooling Fins	18	Removal	19	T	
Engine Oil	13,17	Mowing Tips	14	Throttle Control Cable Adjustment	24
Fuel Filter	18	Muffler	18	Tires	8,16,22
Spark Plug(s)	18	Spark Arrester	3,40	Trouble Shooting Chart	26-27
Tractor:				Transaxle	17
Battery	16-17				
Blade	16			W	
Lubrication Chart	15			Warranty	3
Maintenance Schedule	15			Wiring Diagram	30
Tire Care	8,16,22			Wiring Schematic	29
Transaxle	17				
Cutting Height, Mower	12				



ACCESSORIES AND ATTACHMENTS

These accessories and attachments were available through most Sears retail outlets and service centers when the tractor was purchased. Most Sears stores can order these items for you when you provide the model number of your tractor.

ENGINE

SPARK PLUG	GAS CAN	ENGINE OIL	FUEL STABILIZER	AIR FILTER
				

MAINTENANCE

BLADES	BELTS
	

PERFORMANCE

Sears offers a wide variety of attachments that fit your tractor. Many of these are listed below with brief explanations of how they can help you. This list was current at the time of publication; however, it may change in future years - more attachments may be added, changes may be made in these attachments, or some may no longer be available or fit your model. **Contact your nearest Sears store for the accessories and attachments that are available for your tractor.**

Most of these attachments do not require additional hitches or conversion kits (those that do are indicated) and are designed for easy attaching and detaching.

AERATOR promotes deep root growth for a healthy lawn. Tapered 2.5-inch steel spikes mounted on 10-inch diameter discs puncture holes in soil at close intervals to let moisture soak in. Steel weight tray for increased penetration.

BAGGER lets you collect grass clippings and leaves for a healthier, neater looking lawn. Two Permanex containers hold 30-gallon plastic bags.

BUMPER protects front end of tractor from damage.

CARTS make hauling easy. Variety of sizes available, plus accessories such as side panel kits, tool caddy, cart cover, protective mat and dolly.

CORING AERATOR takes small plugs out of soil to allow moisture and nutrients to reach grass roots. 36-inch swath. 24 hardened steel coring tips. 150 lb. capacity weight tray.

EASY OIL DRAIN VALVE makes oil changes easier, faster.

FRONT NOSE ROLLER canters in front of mower deck to reduce chances of "scalping" on uneven terrain.

GANG HITCH lets you tow 2 or 3 pull-behind attachments at once, such as sweepers, dethatchers, aerators (not for use with rollers, carts or other heavy attachments).

GAUGE WHEELS on both sides of the mower deck reduce chances of "scalping" on uneven terrain. For mower decks not so equipped.

MULCH RAKE/DETHATCHER loosens soil and flips thatch and matted leaves to lawn surface for easy pickup. Twenty spring tine teeth. Useful to prepare bare areas for seeding. Available for front or rear mounting. **HIGH PERFORMANCE REEL-ACTION SPRING TINE DETHATCHER** covers 36-inch wide path and tosses thatch into large hopper. Mounts behind tractor.

MULCHING CLOSE-OUT PLATE KIT, once installed, lets you mulch, discharge or bag clippings (bagger optional) without changing blades. For models not equipped as 3-in-1 Convertible mowers. See "MOWER" in the Repair Parts section of this manual.

RAMP TOPS AND FEET let you load and unload tractor from a pickup truck. Use with 2 x 8 or 2 x 10 lumber.

ROLLER for smoother lawn surface. 36-inch wide, 18-inch diameter water-tight drum holds up to 390 lbs. of weight. Rounded edges prevent harm to turf. Adjustable scraper automatically cleans drum.

SNOW BLADE for snow removal only. 14-inch high, 48-inch wide blade clears 42-inch path when angled left or right. Raises, lowers with side lever. Adjustable skids; replaceable, reversible scraper bar. (Use with tire chains and wheel weights and/or rear drawbar weight.)

SNOWTHROWER has 40-inch swath. Drum-type auger handles powdery and wet/heavy snow. Mounts easily with simple pin arrangement. Discharge chute adjusts from tractor seat. 6-inch diameter spout discharges snow 10 to 50 feet. Lift controlled at tractor seat. (Use with chains and wheel weights and/or rear drawbar weight.)

SPRAYERS use 12-volt DC electric motor that connects to the tractor battery or other 12-volt source. Includes booms for automatic spraying and hand held wand for spot spraying. Wand has adjustable spray pattern. For applying herbicides, insecticides, fungicides and liquid fertilizers.

SPREADER/SEEDERS make seeding, fertilizing, and weed killing easy. Broadcast spreaders are also useful for granular deicers and sand.

SWEEPERS let you collect grass clippings and leaves.

TILLER has 5 hp engine and 36-inch swath to prepare seed beds, cultivate and compost garden residue. Tiller has its own built-in lift and depth control system and does NOT require a sleeve hitch. Fits any lawn, yard or garden tractor. Simply hook up to the tractor drawbar and go! **Optional accessories** convert unit for dethatching, aerating, hilling...without tools.

TIRE CHAINS are heavy duty; closely spaced extra-large cross links give smooth ride, outstanding traction.

TRACTOR CAB has heavy duty vinyl fabric over tubular steel frame, ABS plastic top; clear plastic windshield offers 360 degree visibility. Hinged metal doors with catch. Keeps operator warm and dry. Remove vinyl sides and windshields for use as sun protector in summer. **Optional accessories include:** tinted/tempered solid safety glass windshield with hand operated wiper; 12-volt amber caution light for mounting on cab top.

VACS for powerful collection of heavy grass clippings and leaves. **Optional wand attachment** to pick up debris in hard-to-reach places. **VAC/CHIPPER** includes a chipper-shredder.

WEIGHT BRACKET for drawbar for snow removal applications. Uses (1) 55 lb. weight.

WHEEL WEIGHTS for rear wheels provide needed traction for snow removal or dozing heavy materials.

CONTENTS OF HARDWARE PACK

Parts Bag contents shown full size

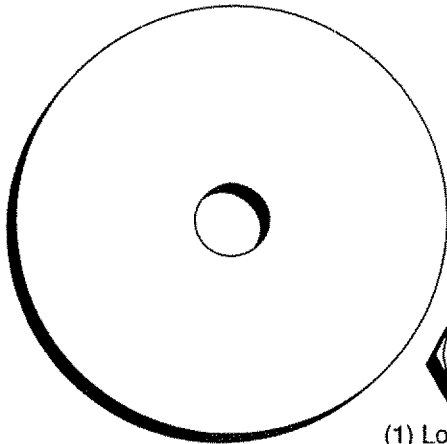

(1) Large Flat Washer



(2) Sheet Metal Screws #10-16 x 1/2



(1) Locknut 3/8-24

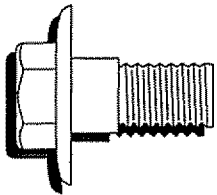

(1) Shoulder Bolt 5/16-18

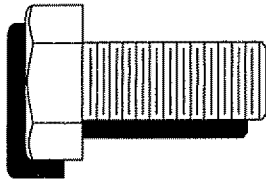

(1) Hex Bolt 1/2-13 x 1

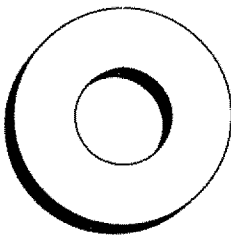

(1) Washer 17/32 x 1-3/16 x 12 Gauge

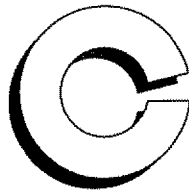

(1) Lock Washer 1/2



(2) Hex Bolts 1/4-20 x 3/4



(2) Hex Nuts 1/4-20



(2) Washers 9/32 x 5/8 x 16 Gauge



(2) Lock Washers 1/4

Parts packed separately in carton

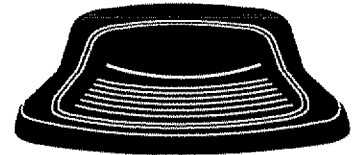

Seat

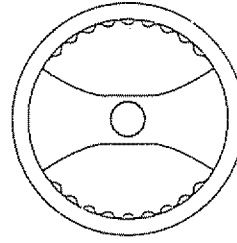

Steering Wheel

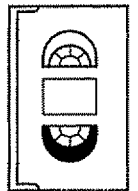

Video Cassette



Steering Boot

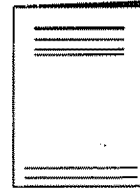

Manual



Parts Bag

Parts bag contents not shown full size

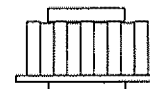

Steering Wheel Adapter

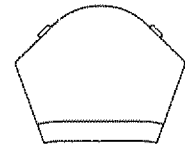

Steering Wheel Insert

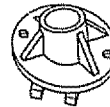

Steering Bushing

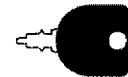

(2) Keys

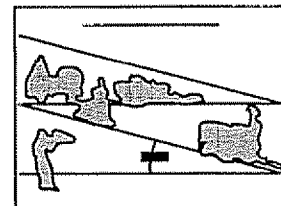

Slope Sheet

ASSEMBLY

Your new tractor has been assembled at the factory with exception of those parts left unassembled for shipping purposes. To ensure safe and proper operation of your tractor all parts and hardware you assemble must be tightened securely. Use the correct tools as necessary to insure proper tightness.

TOOLS REQUIRED FOR ASSEMBLY

A socket wrench set will make assembly easier. Standard wrench sizes are listed.

- | | |
|--------------------|---------------------|
| (1) 5/16" wrench | (1) 3/4" wrench |
| (2) 7/16" wrenches | Tire pressure gauge |
| (1) 1/2" wrench | Utility knife |
| (1) 9/16" wrench | |

When right or left hand is mentioned in this manual, it means when you are in the operating position (seated behind the steering wheel).

TO REMOVE TRACTOR FROM CARTON

UNPACK CARTON

- Remove all accessible loose parts and parts cartons from carton (See page 6).
- Cut, from top to bottom, along lines on all four corners of carton, and lay panels flat.
- Check for any additional loose parts or cartons and remove.

BEFORE ROLLING TRACTOR OFF SKID

ATTACH STEERING WHEEL (See Fig. 1)

- Slide the steering bushing over the steering shaft.
- Raise steering shaft forward until screw holes in dash line up with steering bushing. Install two (2) sheet metal screws and tighten securely.
- Position steering boot over steering shaft.
- Place tabs of steering boot over tab slots in dash and push down to secure.
- Slide steering wheel adapter onto upper steering shaft.
- Position front wheels of the tractor so they are pointing straight forward.
- Position steering wheel so cross bars are horizontal (left to right) and slide onto adapter.
- Assemble large flat washer and 3/8-24 locknut and tighten securely.
- Snap steering wheel insert into center of steering wheel.
- Remove protective plastic from tractor hood and grill.

IMPORTANT: CHECK FOR AND REMOVE ANY STAPLES IN SKID THAT MAY PUNCTURE TIRES WHERE TRACTOR IS TO ROLL OFF SKID.

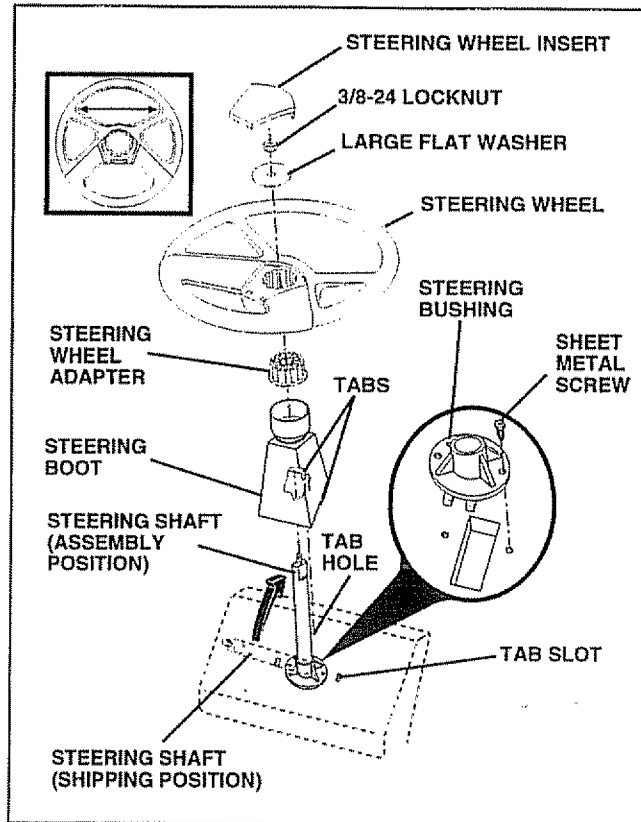

FIG. 1

TO ROLL TRACTOR OFF SKID (See Operation section for location and function of controls)

- Press lift lever plunger and raise attachment lift lever to its highest position.
- Release parking brake by depressing clutch/brake pedal.
- Place gearshift lever in neutral (N) position.
- Roll tractor backwards off skid.
- Remove banding holding discharge guard up against tractor.

ASSEMBLY

CONNECT BATTERY (See Figs. 2 and 3)



CAUTION: Do not short battery terminals. Before connecting battery, remove metal bracelets, wristwatch bands, rings, etc.

Positive terminal must be connected first to prevent sparking from accidental grounding.

- Remove cardboard packing from seat pan and lift seat pan to raised position.
- Open battery box door.
- Remove terminal protective caps and discard.
- If this battery is put into service after month and year indicated on label (label located between terminals) charge battery for minimum of one hour at 6-10 amps.
- First connect RED battery cable to positive (+) terminal with hex bolt, flat washer, lock washer and hex nut as shown. Tighten securely.
- Connect BLACK grounding cable to negative (-) terminal with remaining hex bolt, flat washer, lock washer and hex nut. Tighten securely.
- Close battery box door.

Open battery box door for:

- Inspection for secure connections (to tighten hardware).
- Inspection for corrosion.
- Testing battery.
- Jumping (if required).
- Periodic charging.

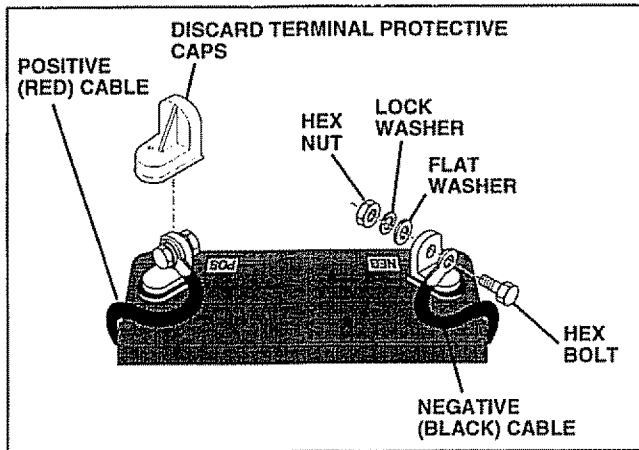

FIG. 2

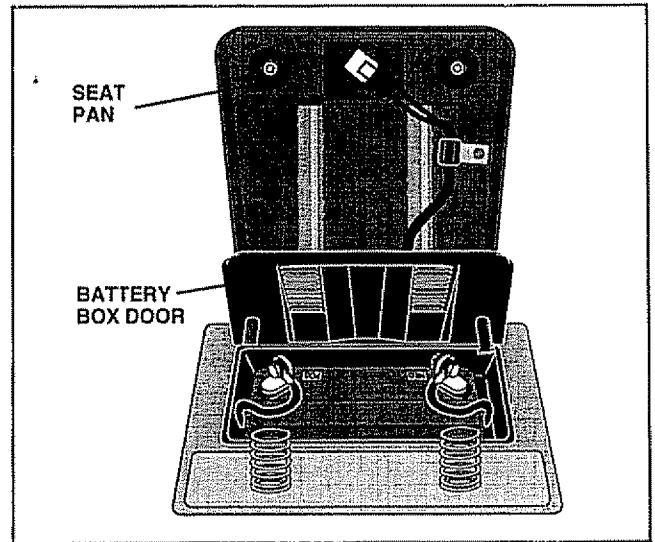

FIG. 3

INSTALL SEAT (See Fig. 4)

Adjust seat before tightening adjustment bolt.

- Remove cardboard packing on seat pan.
- Place seat on seat pan and assemble shoulder bolt.
- Assemble adjustment bolt, lock washer and flat washer loosely. Do not tighten.
- Tighten shoulder bolt securely.
- Lower seat into operating position and sit on seat.
- Slide seat until a comfortable position is reached which allows you to press clutch/brake pedal all the way down.
- Get off seat without moving its adjusted position.
- Raise seat and tighten adjustment bolt securely.

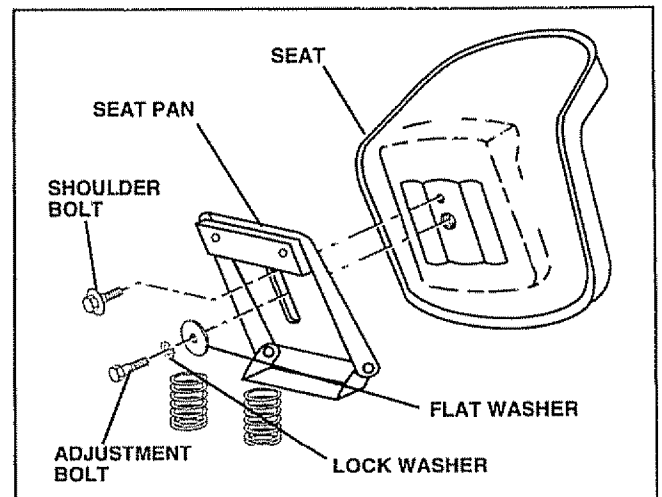

FIG. 4

ASSEMBLY

CHECK TIRE PRESSURE

The tires on your tractor were overinflated at the factory for shipping purposes. Correct tire pressure is important for best cutting performance.

- Reduce tire pressure to PSI shown in "PRODUCT SPECIFICATIONS" on page 3 of this manual.

CHECK DECK LEVELNESS

For best cutting results, mower housing should be properly leveled. See "TO LEVEL MOWER HOUSING" in the Service and Adjustments section of this manual.

CHECK FOR PROPER POSITION OF ALL BELTS

See the figures that are shown for replacing motion and mower blade drive belts in the Service and Adjustments section of this manual. Verify that the belts are routed correctly.

CHECK BRAKE SYSTEM

After you learn how to operate your tractor, check to see that the brake is properly adjusted. See "TO ADJUST BRAKE" in the Service and Adjustments section of this manual.

✓ CHECKLIST

BEFORE YOU OPERATE AND ENJOY YOUR NEW TRACTOR, WE WISH TO ASSURE THAT YOU RECEIVE THE BEST PERFORMANCE AND SATISFACTION FROM THIS QUALITY PRODUCT.

PLEASE REVIEW THE FOLLOWING CHECKLIST:

- ✓ All assembly instructions have been completed.
- ✓ No remaining loose parts in carton.
- ✓ Battery is properly prepared and charged. (Minimum 1 hour at 6 amps).
- ✓ Seat is adjusted comfortably and tightened securely.
- ✓ All tires are properly inflated. (For shipping purposes, the tires were overinflated at the factory).
- ✓ Be sure mower deck is properly leveled side-to-side/ front-to-rear for best cutting results. (Tires must be properly inflated for leveling).
- ✓ Check mower and drive belts. Be sure they are routed properly around pulleys and inside all belt keepers.
- ✓ Check wiring. See that all connections are still secure and wires are properly clamped.

WHILE LEARNING HOW TO USE YOUR TRACTOR, PAY EXTRA ATTENTION TO THE FOLLOWING IMPORTANT ITEMS:

- ✓ Engine oil is at proper level.
- ✓ Fuel tank is filled with fresh, clean, regular unleaded gasoline.
- ✓ Become familiar with all controls - their location and function. Operate them before you start the engine.
- ✓ Be sure brake system is in safe operating condition.

OPERATION

These symbols may appear on your tractor or in literature supplied with the product. Learn and understand their meaning.



BATTERY



CAUTION OR WARNING



REVERSE



FORWARD



FAST



SLOW



ENGINE ON



ENGINE OFF



OIL PRESSURE



CLUTCH



LIGHTS ON



LIGHTS OFF



FUEL



CHOKE



MOWER HEIGHT

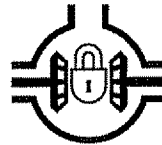

DIFFERENTIAL LOCK



PARKING BRAKE LOCKED



UNLOCKED



MOWER LIFT

R

REVERSE

N

NEUTRAL

H

HIGH

L

LOW



PARKING BRAKE



ATTACHMENT CLUTCH ENGAGED



ATTACHMENT CLUTCH DISENGAGED



IGNITION

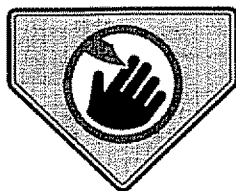

DANGER, KEEP HANDS AND FEET AWAY

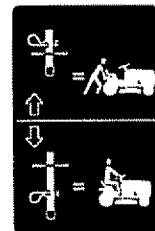
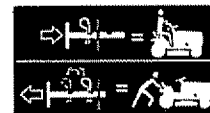

HYDROSTATIC FREE WHEEL
(Hydro Models only)

OPERATION

KNOW YOUR TRACTOR

READ THIS OWNER'S MANUAL AND SAFETY RULES BEFORE OPERATING YOUR TRACTOR

Compare the illustrations with your tractor to familiarize yourself with the locations of various controls and adjustments. Save this manual for future reference.

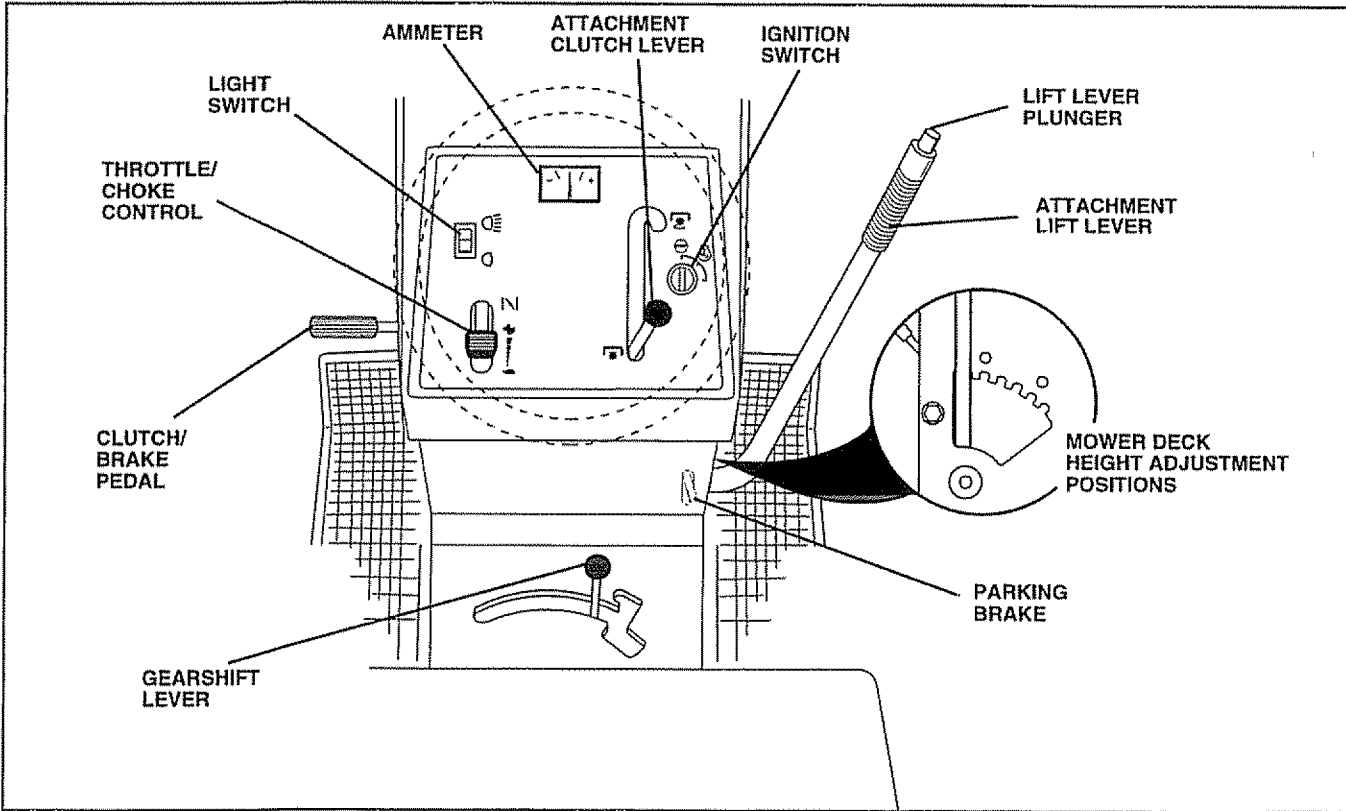

FIG. 5

Our tractors conform to the safety standards of the American National Standards Institute.

ATTACHMENT CLUTCH LEVER: Used to engage the mower blades, or other attachments mounted to your tractor.

LIGHT SWITCH: Turns the headlights on and off.

THROTTLE/CHOKE CONTROL: Used for starting and controlling engine speed.

CLUTCH/BRAKE PEDAL: Used for declutching and braking the tractor and starting the engine.

PARKING BRAKE: Locks clutch/brake pedal into the brake position.

GEARSHIFT LEVER: Selects the speed and direction of tractor.

ATTACHMENT LIFT LEVER: Used to raise, lower, and adjust the mower deck or other attachments mounted to your tractor.

LIFT LEVER PLUNGER: Used to release attachment lift lever when changing its position.

IGNITION SWITCH: Used for starting and stopping the engine.

AMMETER: Indicates battery charging (+) or discharging (-).

OPERATION



The operation of any tractor can result in foreign objects thrown into the eyes, which can result in severe eye damage. Always wear safety glasses or eye shields while operating your tractor or performing any adjustments or repairs. We recommend a wide vision safety mask over the spectacles or standard safety glasses.

HOW TO USE YOUR TRACTOR

TO SET PARKING BRAKE (See Fig. 6)

Your tractor is equipped with an operator presence sensing switch. When engine is running, any attempt by the operator to leave the seat without first setting the parking brake will shut off the engine.

- Depress clutch/brake pedal into full "BRAKE" position and hold.
- Place parking brake lever in "ENGAGED" position and release pressure from clutch/brake pedal. Pedal should remain in "BRAKE" position. Make sure parking brake will hold tractor secure.

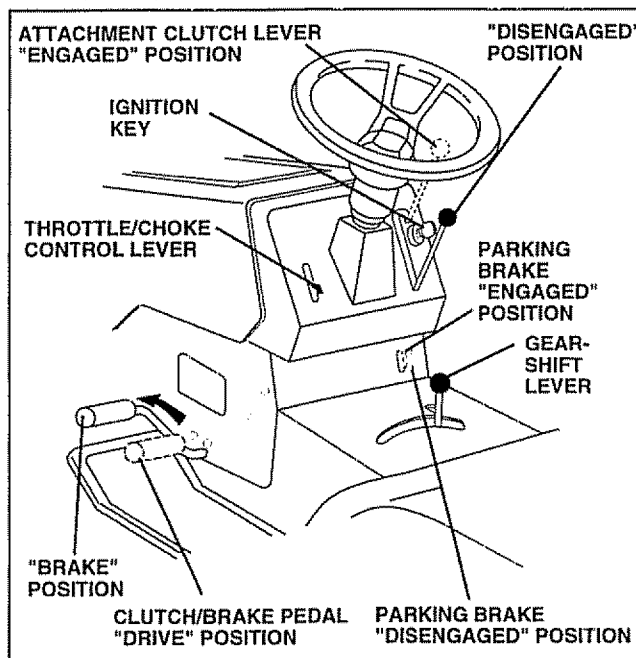

FIG. 6

STOPPING (See Fig. 6)

MOWER BLADES -

- Move attachment clutch lever to "DISENGAGED" position.

GROUND DRIVE -

- Depress clutch/brake pedal into full "BRAKE" position.
- Move gearshift lever to neutral (N) position.

ENGINE -

- Move throttle control to slow (☷) position.

NOTE: Failure to move throttle control to slow (☷) position and allowing engine to idle before stopping may cause engine to "backfire".

- Turn ignition key to "OFF" position and remove key. Always remove key when leaving tractor to prevent unauthorized use.
- Never use choke to stop engine.

NOTE: Under certain conditions when tractor is standing idle with the engine running, hot engine exhaust gases may cause "browning" of grass. To eliminate this possibility, always stop engine when stopping tractor on grass areas.



CAUTION: Always stop tractor completely, as described above, before leaving the operator's position; to empty grass catcher, etc.

TO USE THROTTLE CONTROL (See Fig. 6)

Always operate engine at full throttle.

- Operating engine at less than full throttle reduces the battery charging rate.
- Full throttle offers the best bagging and mower performance.

TO MOVE FORWARD AND BACKWARD (See Fig. 6)

The direction and speed of movement is controlled by the gearshift lever.

- Start tractor with clutch/brake pedal depressed and gearshift lever in neutral (N) position.
- Move gearshift lever to desired position.
- Slowly release clutch/brake pedal to start movement.

IMPORTANT: BRING TRACTOR TO A COMPLETE STOP BEFORE SHIFTING OR CHANGING GEARS. FAILURE TO DO SO WILL SHORTEN THE USEFUL LIFE OF YOUR TRANSAXLE.

TO ADJUST MOWER CUTTING HEIGHT (See Fig. 6)

The position of the attachment lift lever determines the cutting height.

- Grasp lift lever.
- Press plunger with thumb and move lever to desired position.

The cutting height range is approximately 1-1/2 to 4". The heights are measured from the ground to the blade tip with the engine not running. These heights are approximate and may vary depending upon soil conditions, height of grass and types of grass being mowed.

- The average lawn should be cut to approximately 2-1/2 inches during the cool season and to over 3 inches during hot months. For healthier and better looking lawns, mow often and after moderate growth.
- For best cutting performance, grass over 6 inches in height should be mowed twice. Make the first cut relatively high; the second to desired height.

OPERATION

TO OPERATE MOWER (See Fig. 7)

Your tractor is equipped with an operator presence sensing switch. Any attempt by the operator to leave the seat with the engine running and the attachment clutch engaged will shut off the engine.

- Select desired height of cut.
- Start mower blades by engaging attachment clutch control.
- TO STOP MOWER BLADES - disengage attachment clutch control.



CAUTION: Do not operate the mower without either the entire grass catcher, on mowers so equipped, or the discharge guard in place.

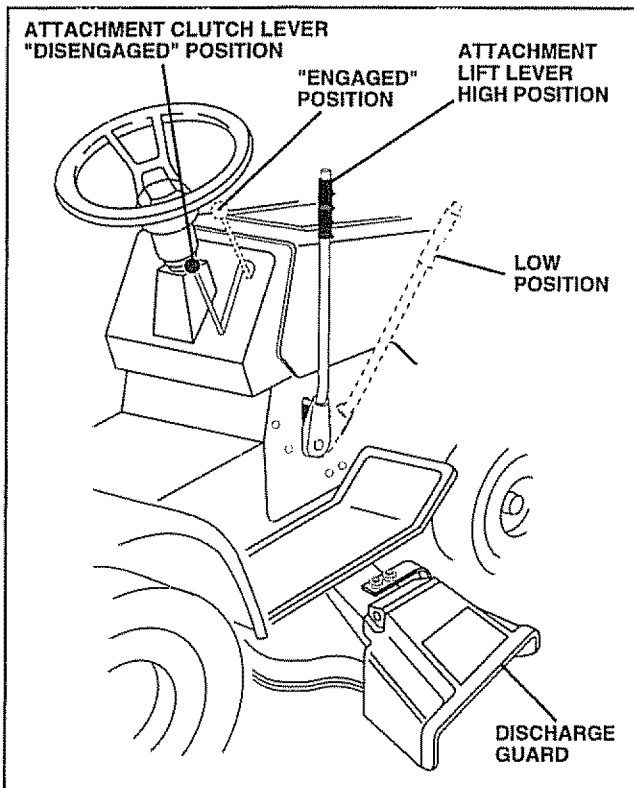

FIG. 7

TO OPERATE ON HILLS



CAUTION: Do not drive up or down hills with slopes greater than 15° and do not drive across any slope.

- Choose the slowest speed before starting up or down hills.
- Avoid stopping or changing speed on hills.
- If slowing is necessary, move throttle control lever to slower position.
- If stopping is absolutely necessary, push clutch/brake pedal quickly to brake position and engage parking brake.
- Move gearshift lever to 1st gear. Be sure you have allowed room for tractor to roll slightly as you restart movement.
- To restart movement, slowly release parking brake and clutch/brake pedal.
- Make all turns slowly.

TO TRANSPORT

- Raise attachment lift to highest position with attachment lift control.
- When pushing or towing your tractor, be sure gearshift lever is in neutral (N) position.
- Do not push or tow tractor at more than five (5) MPH.

NOTE: To protect hood from damage when transporting your tractor on a truck or a trailer, be sure hood is closed and secured to tractor. Use an appropriate means of tying hood to tractor (rope, cord, etc.).

BEFORE STARTING THE ENGINE

CHECK ENGINE OIL LEVEL (See Fig. 12)

- The engine in your tractor has been shipped, from the factory, already filled with summer weight oil.
- Check engine oil with tractor on level ground.
- Remove oil fill cap/dipstick and wipe clean, reinsert the dipstick and screw cap tight, wait for a few seconds, remove and read oil level. If necessary, add oil until "FULL" mark on dipstick is reached. Do not overfill.
- For cold weather operation you should change oil for easier starting (See "OIL VISCOSITY CHART" in the Customer Responsibilities section of this manual).
- To change engine oil, see the Customer Responsibilities section in this manual.

OPERATION

ADD GASOLINE

- Fill fuel tank. Use fresh, clean, regular unleaded gasoline with a minimum of 87 octane. (Use of leaded gasoline will increase carbon and lead oxide deposits and reduce valve life). Do not mix oil with gasoline. Purchase fuel in quantities that can be used within 30 days to assure fuel freshness.

IMPORTANT: WHEN OPERATING IN TEMPERATURES BELOW 32°F(0°C), USE FRESH, CLEAN WINTER GRADE GASOLINE TO HELP INSURE GOOD COLD WEATHER STARTING.

WARNING: Experience indicates that alcohol blended fuels (called gasohol or using ethanol or methanol) can attract moisture which leads to separation and formation of acids during storage. Acidic gas can damage the fuel system of an engine while in storage. To avoid engine problems, the fuel system should be emptied before storage of 30 days or longer. Drain the gas tank, start the engine and let it run until the fuel lines and carburetor are empty. Use fresh fuel next season. See Storage Instructions for additional information. Never use engine or carburetor cleaner products in the fuel tank or permanent damage may occur.



CAUTION: Fill to bottom of gas tank filler neck. Do not overfill. Wipe off any spilled oil or fuel. Do not store, spill or use gasoline near an open flame.

TO START ENGINE (See Fig. 6)

When starting engine for the first time or if engine has run out of fuel, it will take extra cranking time to move fuel from the tank to the engine.

- Depress clutch/brake pedal and set parking brake.
- Place gearshift lever in neutral (N) position.
- Move attachment clutch to "DISENGAGED" position.
- Move throttle control lever to choke (| \ |) position for cold engine start. For warm engine start, move throttle control to fast (←) position.
- Insert key into ignition and turn key clockwise to "START" position and release key as soon as engine starts. Do not run starter continuously for more than fifteen seconds per minute. If engine does not start after several attempts, move throttle control to fast (←) position, wait a few minutes and try again.
- When engine starts, move throttle control to desired position.
- Allow engine to warm up for a few minutes before engaging drive or attachments.

NOTE: If at a high altitude (above 3000 feet) or in cold temperatures (below 32°F), the carburetor fuel mixture may need to be adjusted for best engine performance. See "TO ADJUST CARBURETOR" in the Service and Adjustments section of this manual.

MOWING TIPS

- Tire chains cannot be used when the mower housing is attached to tractor.
- Mower should be properly leveled for best mowing performance. See "TO LEVEL MOWER HOUSING" in the Service and Adjustments section of this manual.
- The left hand side of mower should be used for trimming.
- Drive so that clippings are discharged onto the area that has been cut. Have the cut area to the right of the machine. This will result in a more even distribution of clippings and more uniform cutting.
- When mowing large areas, start by turning to the right so that clippings will discharge away from shrubs, fences, driveways, etc. After one or two rounds, mow in the opposite direction making left hand turns until finished (See Fig. 8).
- If grass is extremely tall, it should be mowed twice to reduce load and possible fire hazard from dried clippings. Make first cut relatively high; the second to the desired height.
- Do not mow grass when it is wet. Wet grass will plug mower and leave undesirable clumps. Allow grass to dry before mowing.
- Always operate engine at full throttle when mowing to assure better mowing performance and proper discharge of material. Regulate ground speed by selecting a low enough gear to give the mower cutting performance as well as the quality of cut desired.
- When operating attachments, select a ground speed that will suit the terrain and give best performance of the attachment being used.

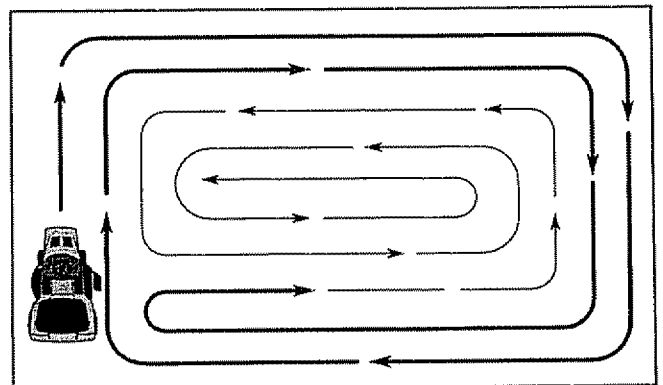

FIG. 8

CUSTOMER RESPONSIBILITIES

MAINTENANCE SCHEDULE FILL IN DATES AS YOU COMPLETE REGULAR SERVICE		SERVICE INTERVALS							SERVICE DATES				
		BEFORE EACH USE ⁴	FIRST 2 HOURS	EVERY 8 HOURS	EVERY 25 HOURS	EVERY 50 HOURS	EVERY 100 HOURS	BEFORE SEASON					BEFORE STORAGE
TRACTOR	Check Brake Operation	✓	✓										
	Check Tire Pressure	✓	✓										
	Check for Loose Fasteners	✓				✓ ⁷	✓						
	Sharpen/Replace Mower Blades			✓ ⁴									
	Lubrication Chart			✓				✓					
	Check Battery Level/Recharge			✓ ⁶									
	Clean Battery and Terminals			✓				✓					
	Check Transaxle Cooling			✓									
	Adjust Blade Belt(s) Tension					✓ ⁵							
	Adjust Motion Drive Belt(s) Tension					✓ ⁵							
ENGINE	Check Engine Oil Level	✓	✓										
	Change Engine Oil		✓	✓ ^{1,2,3}				✓					
	Clean Air Filter			✓ ²									
	Clean Air Screen			✓ ²									
	Inspect Muffler/Spark Arrester				✓								
	Replace Oil Filter (If equipped)					✓ ^{1,2}							
	Clean Engine Cooling Fins					✓ ²							
	Replace Spark Plug					✓	✓						
	Replace Air Filter Paper Cartridge					✓ ²							
	Replace Fuel Filter							✓					

- 1 - Change more often when operating under a heavy load or in high ambient temperatures
- 2 - Service more often when operating in dirty or dusty conditions
- 3 - If equipped with oil filter, change oil every 50 hours
- 4 - Replace blades more often when mowing in sandy soil

- 5 - If equipped with adjustable system
- 6 - Not required if equipped with maintenance-free battery
- 7 - Tighten front axle pivot bolt to 35 ft.-lbs. maximum
Do not overtighten.

GENERAL RECOMMENDATIONS

The warranty on this tractor does not cover items that have been subjected to operator abuse or negligence. To receive full value from the warranty, operator must maintain tractor as instructed in this manual.

Some adjustments will need to be made periodically to properly maintain your tractor.

All adjustments in the Service and Adjustments section of this manual should be checked at least once each season.

- Once a year you should replace the spark plug, clean or replace air filter, and check blades and belts for wear. A new spark plug and clean air filter assure proper air-fuel mixture and help your engine run better and last longer.

BEFORE EACH USE

- Check engine oil level.
- Check brake operation.
- Check tire pressure.
- Check for loose fasteners.

LUBRICATION CHART

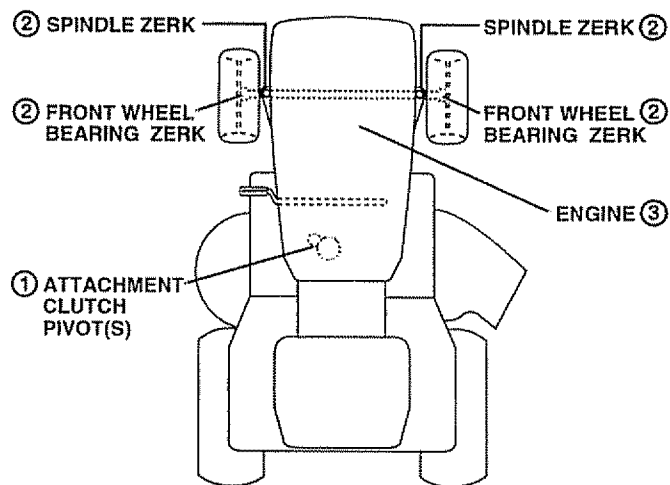

- ① SAE 30 OR 10W30 MOTOR OIL
- ② GENERAL PURPOSE GREASE
- ③ REFER TO CUSTOMER RESPONSIBILITIES "ENGINE" SECTION

IMPORTANT: DO NOT OIL OR GREASE THE PIVOT POINTS WHICH HAVE SPECIAL NYLON BEARINGS. VISCOUS LUBRICANTS WILL ATTRACT DUST AND DIRT THAT WILL SHORTEN THE LIFE OF THE SELF-LUBRICATING BEARINGS. IF YOU FEEL THEY MUST BE LUBRICATED, USE ONLY A DRY, POWDERED GRAPHITE TYPE LUBRICANT SPARINGLY.

CUSTOMER RESPONSIBILITIES

TRACTOR

Always observe safety rules when performing any maintenance.

BRAKE OPERATION

If tractor requires more than six (6) feet stopping distance at high speed in highest gear, then brake must be adjusted. (See "TO ADJUST BRAKE" in the Service and Adjustments section of this manual).

TIRES

- Maintain proper air pressure in all tires (See "PRODUCT SPECIFICATIONS" on page 3 of this manual).
- Keep tires free of gasoline, oil, or insect control chemicals which can harm rubber.
- Avoid stumps, stones, deep ruts, sharp objects and other hazards that may cause tire damage.

BLADE CARE

For best results mower blades must be kept sharp. Replace bent or damaged blades.

BLADE REMOVAL (See Fig. 9)

- Raise mower to highest position to allow access to blades.
- Remove hex bolt, lock washer and flat washer securing blade.
- Install new or resharpened blade with trailing edge up towards deck as shown.
- Reassemble hex bolt, lock washer and flat washer in exact order as shown.
- Tighten bolt securely (30-35 Ft. Lbs. torque).

IMPORTANT: BLADE BOLT IS GRADE 8 HEAT TREATED.

NOTE: We do not recommend sharpening blade - but if you do, be sure the blade is balanced.

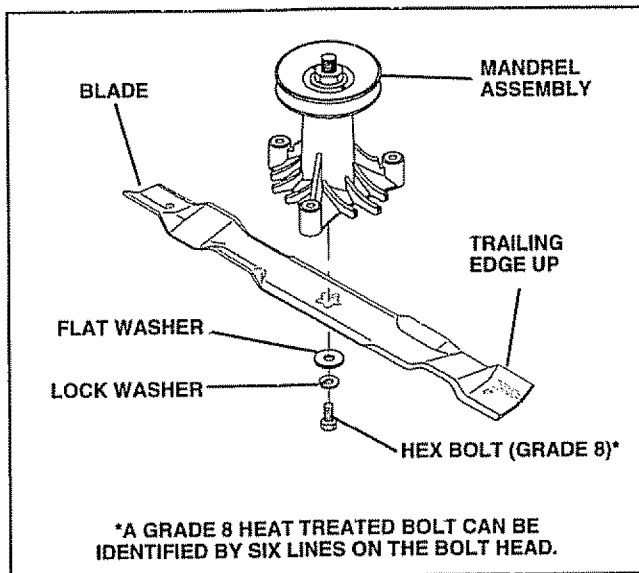

FIG. 9

TO SHARPEN BLADE (See Fig. 10)

Care should be taken to keep the blade balanced. An unbalanced blade will cause excessive vibration and eventual damage to mower and engine.

- The blade can be sharpened with a file or on a grinding wheel. Do not attempt to sharpen while on the mower.
- To check blade balance, you will need a 5/8" diameter steel bolt, pin, or a cone balancer. (When using a cone balancer, follow the instructions supplied with balancer).
- Slide blade on to an unthreaded portion of the steel bolt or pin and hold the bolt or pin parallel with the ground. If blade is balanced, it should remain in a horizontal position. If either end of the blade moves downward, sharpen the heavy end until the blade is balanced.

NOTE: Do not use a nail for balancing blade. The lobes of the center hole may appear to be centered, but are not.

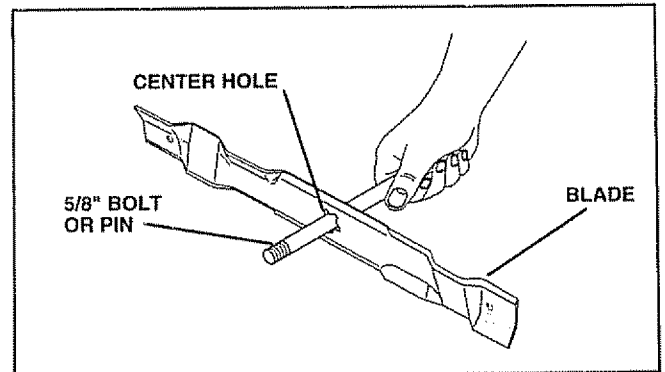

FIG. 10

BATTERY

Your tractor has a battery charging system which is sufficient for normal use. However, periodic charging of the battery with an automotive charger will extend its life.

- Keep battery and terminals clean.
- Keep battery bolts tight.
- Keep small vent holes open.
- Recharge at 6-10 amperes for 1 hour.

TO CLEAN BATTERY AND TERMINALS

Corrosion and dirt on the battery and terminals can cause the battery to "leak" power.

- Open battery box door.
- Disconnect BLACK battery cable first then RED battery cable and remove battery from tractor.
- Rinse the battery with plain water and dry.
- Clean terminals and battery cable ends with wire brush until bright.
- Coat terminals with grease or petroleum jelly.
- Reinstall battery (See "CONNECT BATTERY" in the Assembly section of this manual).

CUSTOMER RESPONSIBILITIES

V-BELTS

Check V-belts for deterioration and wear after 100 hours of operation and replace if necessary. The belts are not adjustable. Replace belts if they begin to slip from wear.

TRANSAXLE COOLING

Keep transaxle free from build-up of dirt and chaff which can restrict cooling.

ENGINE

LUBRICATION

Only use high quality detergent oil rated with API service classification SF or SG. Select the oil's SAE viscosity grade according to your expected operating temperature.

NOTE: Although multi-viscosity oils (5W30, 10W30 etc.) improve starting in cold weather, these multi-viscosity oils will result in increased oil consumption when used above 32°F. Check your engine oil level more frequently to avoid possible engine damage from running low on oil.

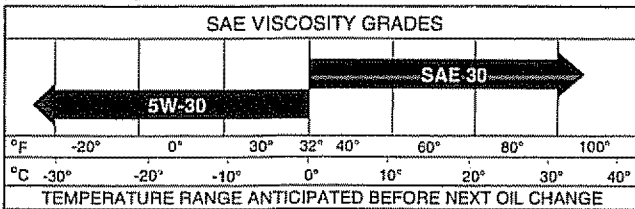

FIG. 11

Change the oil after the first two hours of operation and every 25 hours thereafter or at least once a year if the tractor is not used for 25 hours in one year.

Check the crankcase oil level before starting the engine and after each eight (8) hours of operation. Tighten oil fill cap/dipstick securely each time you check the oil level.

TO CHANGE ENGINE OIL (See Figs. 11 and 12)

Determine temperature range expected before oil change. All oil must meet API service classification SF or SG.

- Be sure tractor is on level surface.
- Oil will drain more freely when warm.
- Catch oil in a suitable container.
- Remove oil fill cap/dipstick. Be careful not to allow dirt to enter the engine when changing oil.
- Remove drain plug.
- After oil has drained completely, replace oil drain plug and tighten securely.
- Refill engine with oil through oil fill dipstick tube. Pour slowly. Do not overfill. For approximate capacity see "PRODUCT SPECIFICATIONS" on page 3 of this manual.
- Use gauge on oil fill cap/dipstick for checking level. Be sure dipstick cap is tightened securely for accurate reading. Keep oil at "FULL" line on dipstick.

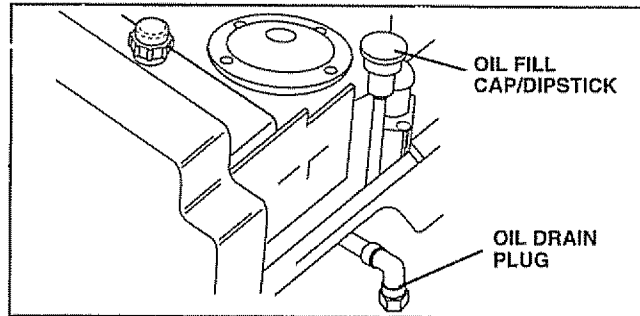

FIG. 12

AIR FILTER (See Fig. 13)

Your engine will not run properly using a dirty air filter. Clean the foam pre-cleaner after every 25 hours of operation or every season. Service paper cartridge every 100 hours of operation or every season, whichever occurs first.

Service air cleaner more often under dusty conditions.

- Remove knob(s) and cover.

TO SERVICE PRE-CLEANER

- Slide foam pre-cleaner off cartridge.
- Wash it in liquid detergent and water.
- Squeeze it dry in a clean cloth.
- Saturate it in engine oil. Wrap it in clean, absorbent cloth and squeeze to remove excess oil.
- If very dirty or damaged, replace pre-cleaner.
- Reinstall pre-cleaner over cartridge.
- Reinstall cover and secure with knob(s)

TO SERVICE CARTRIDGE

- Remove cartridge nut.
- Carefully remove cartridge to prevent debris from entering carburetor. Clean base carefully to prevent debris from entering carburetor.
- Clean cartridge by tapping gently on flat surface. If very dirty or damaged, replace cartridge.
- Reinstall cartridge, nut, pre-cleaner, cover and secure with knob(s).

IMPORTANT: PETROLEUM SOLVENTS, SUCH AS KEROSENE, ARE NOT TO BE USED TO CLEAN THE CARTRIDGE. THEY MAY CAUSE DETERIORATION OF THE CARTRIDGE. DO NOT OIL CARTRIDGE. DO NOT USE PRESSURIZED AIR TO CLEAN OR DRY CARTRIDGE.

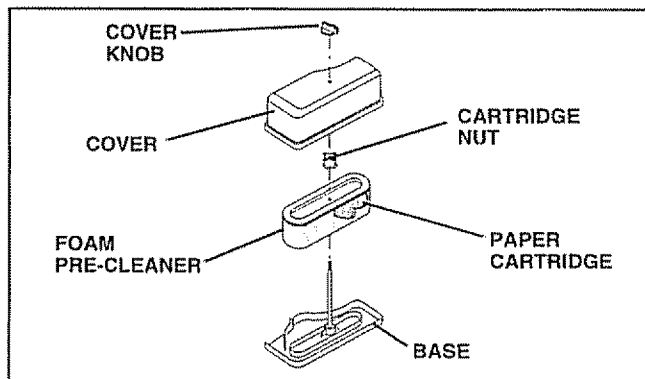

FIG. 13

CUSTOMER RESPONSIBILITIES

CLEAN AIR SCREEN (See Fig. 14)

Air screen must be kept free of dirt and chaff to prevent engine damage from overheating. Clean with a wire brush or compressed air to remove dirt and stubborn dried gum fibers.

ENGINE COOLING FINS (See Fig. 14)

Remove any dust, dirt or oil from engine cooling fins to prevent engine damage from overheating.

- Remove screws from blower housing and lift housing and oil fill tube assembly off engine.
- Cover oil fill opening to prevent entry of dirt.
- Remove the screws securing the starter housing and lift housing off engine.
- Use compressed air or stiff bristle brush to thoroughly clean engine cooling fins.
- To reassemble, reverse above procedure.

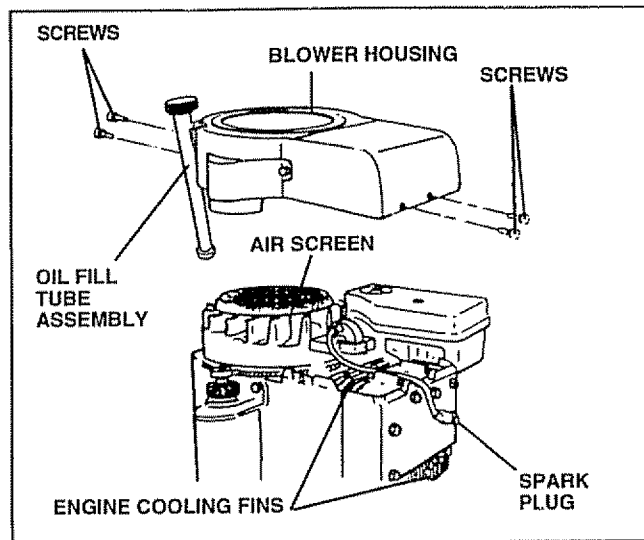

FIG. 14

MUFFLER

Inspect and replace corroded muffler and spark arrester (if equipped) as it could create a fire hazard and/or damage.

SPARK PLUGS

Replace spark plugs at the beginning of each mowing season or after every 100 hours of operation, whichever occurs first. Spark plug type and gap setting are shown in "PRODUCT SPECIFICATIONS" on page 3 of this manual.

IN-LINE FUEL FILTER (See Fig. 15)

The fuel filter should be replaced once each season. If fuel filter becomes clogged, obstructing fuel flow to carburetor, replacement is required.

- With engine cool, remove filter and plug fuel line sections.
- Place new fuel filter in position in fuel line with arrow pointing towards carburetor.
- Be sure there are no fuel line leaks and clamps are properly positioned.
- Immediately wipe up any spilled gasoline.

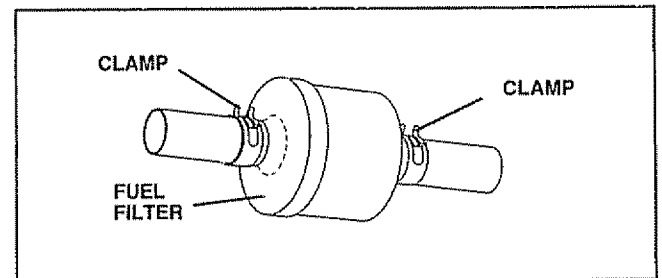

FIG. 15

CLEANING

- Clean engine, battery, seat, finish, etc. of all foreign matter.
- Keep finished surfaces and wheels free of all gasoline, oil, etc.
- Protect painted surfaces with automotive type wax.

We do not recommend using a garden hose to clean your tractor unless the electrical system, muffler, air filter and carburetor are covered to keep water out. Water in engine can result in a shortened engine life.

SERVICE AND ADJUSTMENTS



CAUTION: BEFORE PERFORMING ANY SERVICE OR ADJUSTMENTS:

- Depress clutch/brake pedal fully and set parking brake.
- Place gearshift lever in neutral (N) position.
- Place attachment clutch in "DISENGAGED" position.
- Turn ignition key "OFF" and remove key.
- Make sure the blades and all moving parts have completely stopped.
- Disconnect spark plug wire from spark plug and place wire where it cannot come in contact with plug.

TO REMOVE MOWER (See Fig. 16)

Mower will be easier to remove from the right side of tractor.

- Place attachment clutch in "DISENGAGED" position.
- Move attachment lift lever forward to lower mower to its lowest position.
- Roll belt off engine pulley.
- Disconnect clutch rod from clutch lever by removing retainer spring.
- Disconnect anti-sway bar from chassis bracket by removing retainer spring.
- Disconnect suspension arms from rear deck brackets by removing retainer springs.
- Disconnect front links from deck by removing retainer springs.
- Raise lift lever to raise suspension arms. Slide mower out from under tractor.

IMPORTANT: IF AN ATTACHMENT OTHER THAN THE MOWER IS TO BE MOUNTED TO THE TRACTOR, REMOVE THE FRONT LINKS.

TO INSTALL MOWER (See Fig. 16)

- Raise attachment lift lever to its highest position.
- Slide mower under tractor with discharge guard to right side of tractor.
- Lower lift lever to its lowest position.
- Install mower in reverse order of removal instructions.

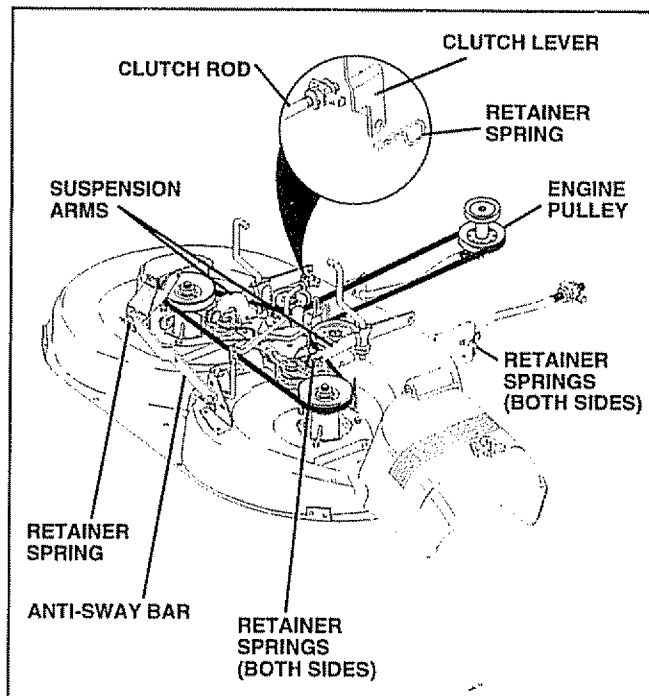

FIG. 16

SERVICE AND ADJUSTMENTS

TO LEVEL MOWER HOUSING

Adjust the mower while tractor is parked on level ground or driveway. Make sure tires are properly inflated (See "PRODUCT SPECIFICATIONS" on page 3 of this manual). If tires are over or underinflated, you will not properly adjust your mower.

SIDE-TO-SIDE ADJUSTMENT (See Figs. 17 and 18)

- Raise mower to its highest position.
- At the midpoint of both sides of mower, measure height from bottom edge of mower to ground. Distance "A" on both sides of mower should be the same or within 1/4" of each other.
- If adjustment is necessary, make adjustment on one side of mower only.
- To raise one side of mower, tighten lift link adjustment nut on that side.
- To lower one side of mower, loosen lift link adjustment nut on that side.

NOTE: Each full turn of adjustment nut will change mower height about 1/8".

- Recheck measurements after adjusting.

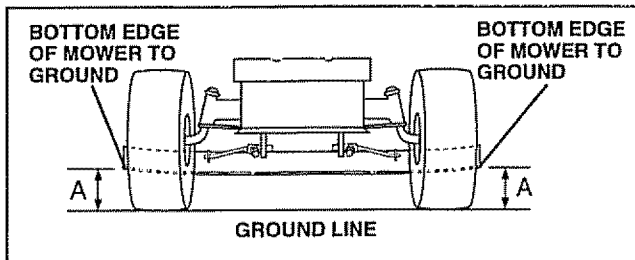

FIG. 17

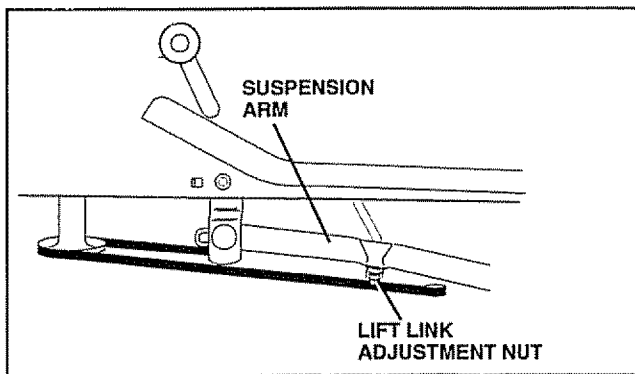

FIG. 18

FRONT-TO-BACK ADJUSTMENT (See Figs. 19 and 20)

IMPORTANT: DECK MUST BE LEVEL SIDE-TO-SIDE. IF THE FOLLOWING FRONT-TO-BACK ADJUSTMENT IS NECESSARY, BE SURE TO ADJUST BOTH FRONT LINKS EQUALLY SO MOWER WILL STAY LEVEL SIDE-TO-SIDE.

To obtain the best cutting results, the mower housing should be adjusted so that the front is approximately 1/4" to 3/4" lower than the rear when the mower is in its highest position.

Check adjustment on right side of tractor. Measure distance "D" directly in front and behind the mandrel at bottom edge of mower housing as shown.

- Before making any necessary adjustments, check that both front links are equal in length. Both links should be approximately 10-3/8".
- If links are not equal in length, adjust one link to same length as other link.
- To lower front of mower loosen nut "E" on both front links an equal number of turns.
- When distance "D" is 1/4" to 3/4" lower at front than rear, tighten nuts "F" against trunnion on both front links.
- To raise front of mower, loosen nut "F" from trunnion on both front links. Tighten nut "E" on both front links an equal number of turns.
- When distance "D" is 1/4" to 3/4" lower at front than rear, tighten nut "F" against trunnion on both front links.
- Recheck side-to-side adjustment.

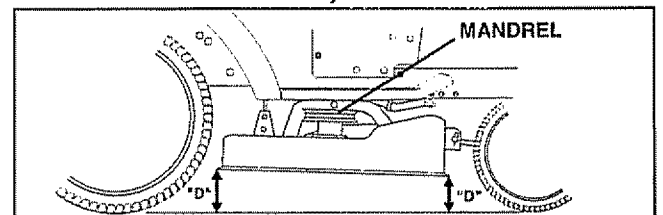

FIG. 19

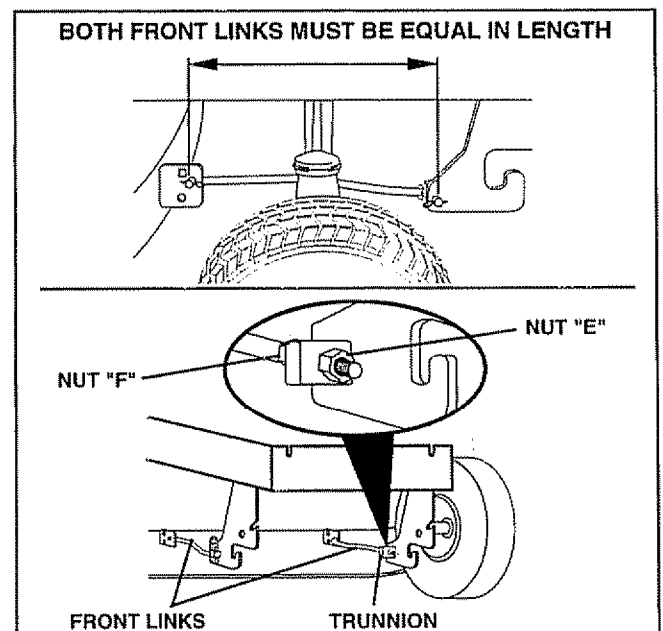

FIG. 20

SERVICE AND ADJUSTMENTS

TO REPLACE MOWER BLADE DRIVE BELT (See Fig. 21)

The mower blade drive belt may be replaced without tools. Park the tractor on level surface. Engage parking brake.

BELT REMOVAL -

- Remove mower from tractor (See "TO REMOVE MOWER" in this section of this manual).
- Work belt off both mandrel pulleys and idler pulleys.
- Pull belt away from mower.

BELT INSTALLATION -

- Install new belt in reverse order of removal.
- Make sure belt is in all pulley grooves and inside all belt guides.
- Install mower in reverse order of removal instructions.

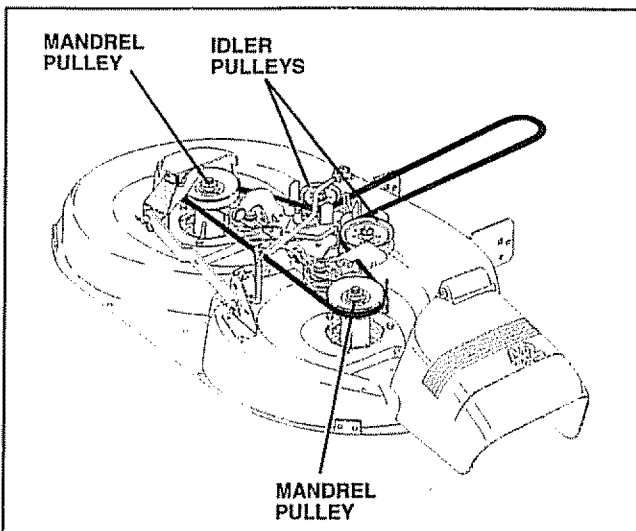

FIG. 21

TO ADJUST BRAKE (See Fig. 22)

Your tractor is equipped with an adjustable brake system which is mounted on the right side of the transaxle.

If tractor requires more than six (6) feet stopping distance at high speed in highest gear, then brake must be adjusted.

- Depress clutch/brake pedal and engage parking brake.
- Measure distance between brake operating arm and nut "A" on brake rod.
- If distance is other than 1-1/2", loosen jam nut and turn nut "A" until distance becomes 1-1/2". Retighten jam nut against nut "A".
- Road test tractor for proper stopping distance as stated above. Readjust if necessary. If stopping distance is still greater than six (6) feet in highest gear, further maintenance is necessary. Contact your nearest authorized service center/department.

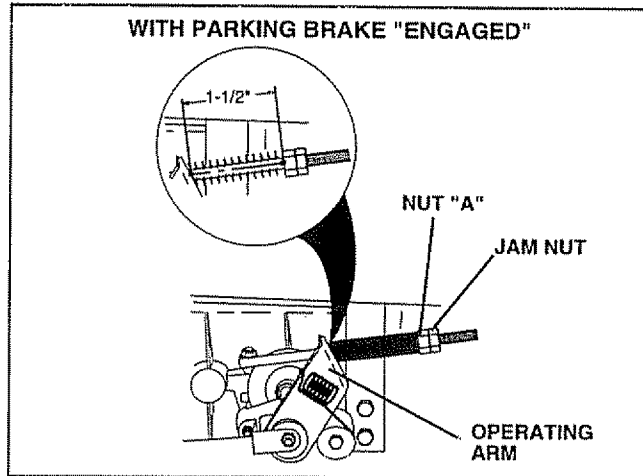

FIG. 22

TO REPLACE MOTION DRIVE BELT (See Fig. 23)

Park the tractor on level surface. Engage parking brake. For assistance, there is a belt installation guide decal on bottom side of left footrest.

- Remove mower (See "TO REMOVE MOWER" in this section of this manual.)
- Remove upper belt keeper.
- Remove belt from stationary idler and clutching idler.
- Pull belt slack toward rear of tractor. Remove belt upwards from transaxle pulley by deflecting belt keepers.
- Pull belt toward front of tractor and remove downwards from around engine pulley.
- Install new belt by reversing above procedure.

IMPORTANT: MAKE SURE UPPER BELT KEEPER IS POSITIONED PROPERLY BETWEEN LOCATOR TABS.

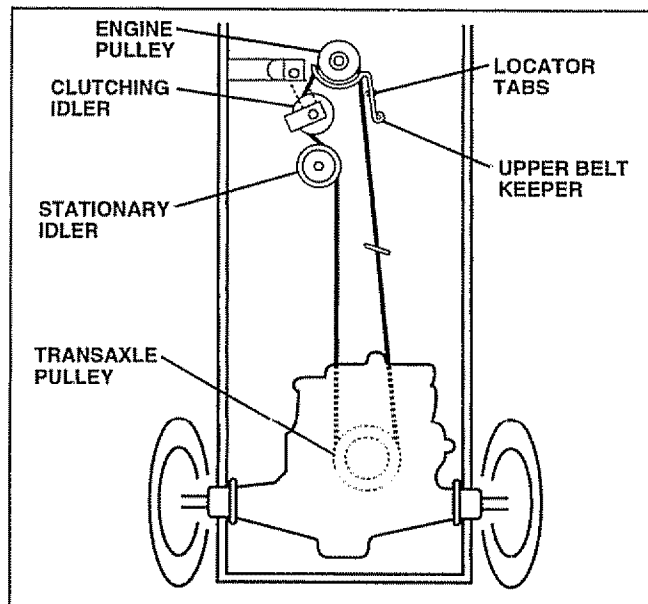

FIG. 23

SERVICE AND ADJUSTMENTS

TO ADJUST STEERING WHEEL ALIGNMENT

If steering wheel crossbars are not horizontal (left to right) when wheels are positioned straight forward, remove steering wheel and reassemble per instructions in the Assembly section of this manual.

FRONT WHEEL TOE-IN/CAMBER

The front wheel toe-in and camber are not adjustable on your tractor. If damage has occurred to affect the front wheel toe-in or camber, contact your nearest authorized service center/department.

TO REMOVE WHEEL FOR REPAIRS (See Fig. 24)

- Block up axle securely.
- Remove axle cover, retaining ring and washers to allow wheel removal (rear wheel contains a square key - Do not lose).
- Repair tire and reassemble.
- On rear wheels only: align grooves in rear wheel hub and axle. Insert square key.
- Replace washers and snap retaining ring securely in axle groove.
- Replace axle cover.

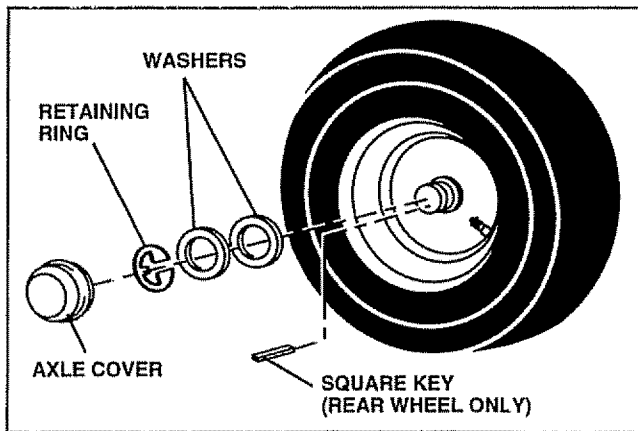

FIG. 24

TO START ENGINE WITH A WEAK BATTERY (See Fig. 25)



CAUTION: Lead-acid batteries generate explosive gases. Keep sparks, flame and smoking materials away from batteries. Always wear eye protection when around batteries.

If your battery is too weak to start the engine, it should be recharged. If "jumper cables" are used for emergency starting, follow this procedure:

IMPORTANT: YOUR TRACTOR IS EQUIPPED WITH A 12 VOLT NEGATIVE GROUND SYSTEM. THE OTHER VEHICLE MUST ALSO BE A 12 VOLT NEGATIVE GROUND SYSTEM. DO NOT USE YOUR TRACTOR BATTERY TO START OTHER VEHICLES.

TO ATTACH JUMPER CABLES -

- Connect each end of the RED cable to the POSITIVE (+) terminal of each battery, taking care not to short against chassis.
- Connect one end of the BLACK cable to the NEGATIVE (-) terminal of fully charged battery.
- Connect the other end of the BLACK cable to good CHASSIS GROUND, away from fuel tank and battery.

TO REMOVE CABLES, REVERSE ORDER -

- BLACK cable first from chassis and then from the fully charged battery.
- RED cable last from both batteries.

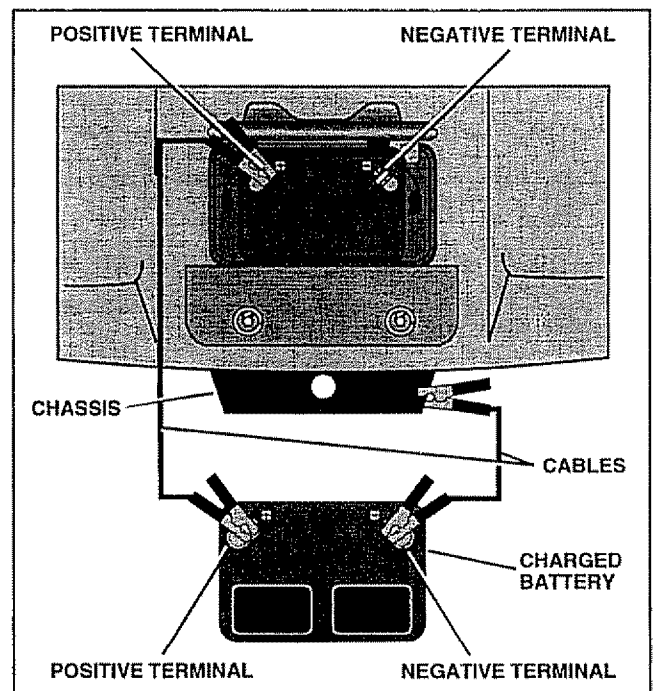

FIG. 25

SERVICE AND ADJUSTMENTS

TO REPLACE HEADLIGHT BULB

- Raise hood.
- Pull bulb holder out of the hole in the backside of the grill.
- Replace bulb in holder and push bulb holder securely back into the hole in the backside of the grill.
- Close hood.

INTERLOCKS AND RELAYS

Loose or damaged wiring may cause your tractor to run poorly, stop running, or prevent it from starting.

- Check wiring. See electrical wiring diagram in the Repair Parts section of this manual.

TO REPLACE FUSE

Replace with 30 amp automotive-type plug-in fuse. The fuse holder is located behind the dash.

TO REMOVE HOOD AND GRILL ASSEMBLY (See Fig. 26)

- Raise hood.
- Unsnap headlight wire connector.
- Stand in front of tractor. Grasp hood at sides, tilt toward engine and lift off of tractor.
- To replace, reverse above procedures.

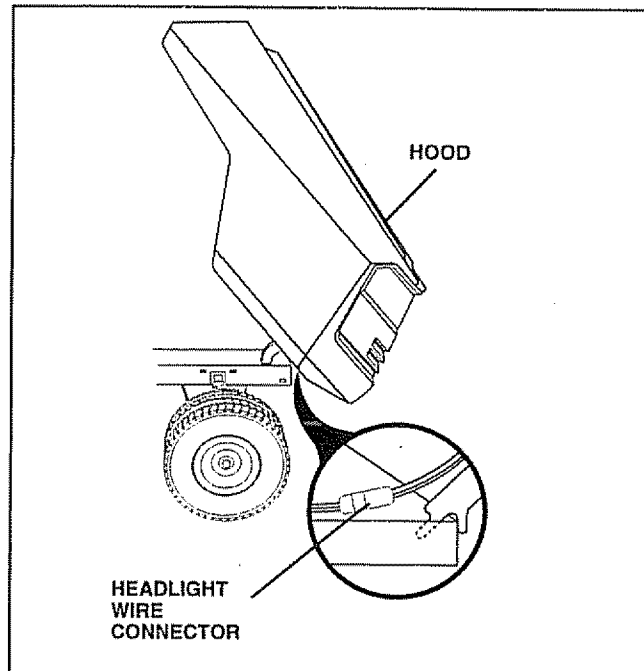

FIG. 26

SERVICE AND ADJUSTMENTS

ENGINE

TO ADJUST THROTTLE CONTROL CABLE (See Fig. 27)

The throttle control has been preset at the factory and adjustment should not be necessary. Check adjustment as described below before loosening cable. If adjustment is necessary, proceed as follows:

- With engine not running, move throttle control lever from slow (☛) to choke (☚) position. Slowly move lever from choke (☚) to fast (☜) position.
- Check that holes "A" in governor control lever and hole in governor control plate line-up. If holes "A" are not aligned, loosen clamp screw and move throttle cable until holes are aligned. Tighten clamp screw securely.

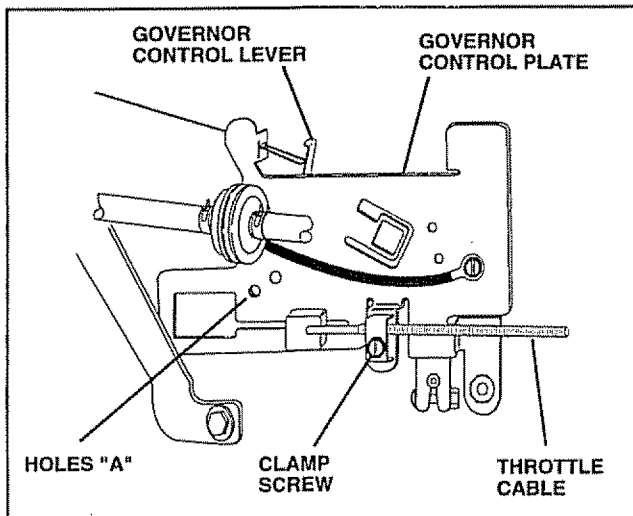

FIG. 27

TO ADJUST CARBURETOR (See Fig. 28)

The carburetor has been preset at the factory and adjustment should not be necessary. However, minor adjustment may be required to compensate for differences in fuel, temperature, altitude or load. If the carburetor does need adjustment, proceed as follows:

In general, turning idle mixture valve **in** (clockwise) decreases the supply of fuel to the engine giving a leaner fuel/air mixture. Turning the idle mixture valve **out** (counterclockwise) increases the supply of fuel to the engine giving a richer fuel/air mixture.

IMPORTANT: DAMAGE TO THE NEEDLE VALVE AND THE SEAT IN CARBURETOR MAY RESULT IF SCREW IS TURNED IN TOO TIGHT.

PRELIMINARY SETTING -

- Air cleaner assembly must be assembled to the carburetor when making carburetor adjustments.
- Be sure the throttle control cable is adjusted properly (see above).
- With engine off turn idle mixture valve **in** (clockwise) closing it finger tight and then turn **out** (counterclockwise) 1 full turn.

FINAL SETTING -

- Start engine and allow to warm for five minutes. Make final adjustments with engine running and shift/motion control lever in neutral (N) position.
- Move throttle control lever to slow (☛) position. With finger, rotate and hold throttle lever against idle speed screw. Turn idle speed screw to attain 1750 RPM.
- While still holding throttle lever against idle speed screw, turn idle mixture valve **in** (clockwise) until engine begins to die and then turn **out** (counterclockwise) until engine runs rough. Turn valve to a point midway between those two positions. Release throttle lever.

ACCELERATION TEST -

- Move throttle control lever from slow (☛) to fast (☜) position. If engine hesitates or dies, turn idle mixture valve **out** (counterclockwise) 1/8 turn. Repeat test and continue to adjust, if necessary, until engine accelerates smoothly.

High speed stop is factory adjusted. Do not adjust - damage may result.

IMPORTANT: NEVER TAMPER WITH THE ENGINE GOVERNOR, WHICH IS FACTORY SET FOR PROPER ENGINE SPEED. OVERSPEEDING THE ENGINE ABOVE THE FACTORY HIGH SPEED SETTING CAN BE DANGEROUS. IF YOU THINK THE ENGINE-GOVERNED HIGH SPEED NEEDS ADJUSTING, CONTACT YOUR NEAREST AUTHORIZED SERVICE CENTER/DEPARTMENT, WHICH HAS PROPER EQUIPMENT AND EXPERIENCE TO MAKE ANY NECESSARY ADJUSTMENTS.

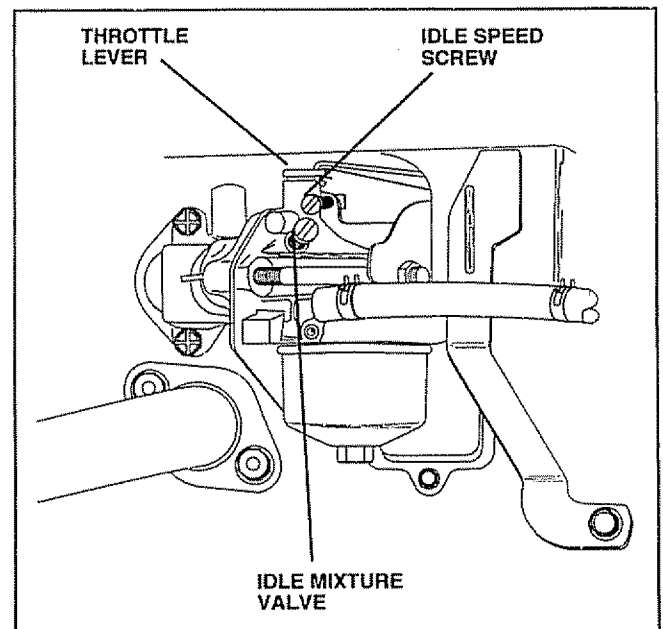

FIG. 28

STORAGE

Immediately prepare your tractor for storage at the end of the season or if the tractor will not be used for 30 days or more.



CAUTION: Never store the tractor with gasoline in the tank inside a building where fumes may reach an open flame or spark. Allow the engine to cool before storing in any enclosure.

TRACTOR

Remove mower from tractor for winter storage. When mower is to be stored for a period of time, clean it thoroughly, remove all dirt, grease, leaves, etc. Store in a clean, dry area.

- Clean entire tractor (See "CLEANING" in the Customer Responsibilities section of this manual).
- Inspect and replace belts, if necessary (See belt replacement instructions in the Service and Adjustments section of this manual).
- Lubricate as shown in the Customer Responsibilities section of this manual.
- Be sure that all nuts, bolts and screws are securely fastened. Inspect moving parts for damage, breakage and wear. Replace if necessary.
- Touch up all rusted or chipped paint surfaces; sand lightly before painting.

BATTERY

- Fully charge the battery for storage.
- After a period of time in storage, battery may require recharging.
- To help prevent corrosion and power leakage during long periods of storage, battery cables should be disconnected and battery cleaned thoroughly (see "TO CLEAN BATTERY AND TERMINALS" in the Customer Responsibilities section of this manual).
- After cleaning, leave cables disconnected and place cables where they cannot come in contact with battery terminals.
- Be sure battery drain tube is securely attached.
- If battery is removed from tractor for storage, do not store battery directly on concrete or damp surfaces.

ENGINE

FUEL SYSTEM

IMPORTANT: IT IS IMPORTANT TO PREVENT GUM DEPOSITS FROM FORMING IN ESSENTIAL FUEL SYSTEM PARTS SUCH AS CARBURETOR, FUEL FILTER, FUEL HOSE, OR TANK DURING STORAGE. ALSO, EXPERIENCE INDICATES THAT ALCOHOL BLENDED FUELS (CALLED GASOHOL OR USING ETHANOL OR METHANOL) CAN ATTRACT MOISTURE WHICH LEADS TO SEPARATION AND FORMATION OF ACIDS DURING STORAGE. ACIDIC GAS CAN DAMAGE THE FUEL SYSTEM OF AN ENGINE WHILE IN STORAGE.

- Drain the fuel tank.
- Start the engine and let it run until the fuel lines and carburetor are empty.
- Never use engine or carburetor cleaner products in the fuel tank or permanent damage may occur.
- Use fresh fuel next season.

NOTE: Fuel stabilizer is an acceptable alternative in minimizing the formation of fuel gum deposits during storage. Add stabilizer to gasoline in fuel tank or storage container. Always follow the mix ratio found on stabilizer container. Run engine at least 10 minutes after adding stabilizer to allow the stabilizer to reach the carburetor. Do not drain the gas tank and carburetor if using fuel stabilizer.

ENGINE OIL

Drain oil (with engine warm) and replace with clean engine oil. (See "ENGINE" in the Customer Responsibilities section of this manual).

CYLINDERS

- Remove spark plug(s).
- Pour one ounce of oil through spark plug hole(s) into cylinder(s).
- Turn ignition key to "START" position for a few seconds to distribute oil.
- Replace with new spark plug(s).

OTHER

- Do not store gasoline from one season to another.
- Replace your gasoline can if your can starts to rust. Rust and/or dirt in your gasoline will cause problems.
- If possible, store your tractor indoors and cover it to give protection from dust and dirt.
- Cover your tractor with a suitable protective cover that does not retain moisture. Do not use plastic. Plastic cannot breathe which allows condensation to form and will cause your tractor to rust.

IMPORTANT: NEVER COVER TRACTOR WHILE ENGINE AND EXHAUST AREAS ARE STILL WARM.

TROUBLESHOOTING POINTS

PROBLEM	CAUSE	CORRECTION
Will not start	<ol style="list-style-type: none"> 1. Out of fuel 2. Engine not "CHOKED" properly 3. Engine flooded. 4. Bad spark plug 5. Dirty air filter. 6. Dirty fuel filter 7. Water in fuel 8. Loose or damaged wiring 9. Carburetor out of adjustment. 10. Engine valves out of adjustment. 	<ol style="list-style-type: none"> 1. Fill fuel tank. 2. See "TO START ENGINE" in Operation section. 3. Wait several minutes before attempting to start 4. Replace spark plug. 5. Clean/replace air filter. 6. Replace fuel filter. 7. Drain fuel tank and carburetor, refill tank with fresh gasoline and replace fuel filter. 8. Check all wiring 9. Contact an authorized service center/department. 10. Contact an authorized service center/department.
Hard to start	<ol style="list-style-type: none"> 1. Dirty air filter. 2. Bad spark plug. 3. Weak or dead battery. 4. Dirty fuel filter. 5. Stale or dirty fuel 6. Loose or damaged wiring. 7. Carburetor out of adjustment. 8. Engine valves out of adjustment 	<ol style="list-style-type: none"> 1. Clean/replace air filter. 2. Replace spark plug 3. Recharge or replace battery. 4. Replace fuel filter. 5. Drain fuel tank and refill with fresh gasoline. 6. Check all wiring. 7. Contact an authorized service center/department. 8. Contact an authorized service center/department.
Engine will not turn over	<ol style="list-style-type: none"> 1. Clutch/brake pedal not depressed 2. Attachment clutch is engaged. 3. Weak or dead battery. 4. Blown fuse 5. Corroded battery terminals 6. Loose or damaged wiring. 7. Faulty ignition switch. 8. Faulty solenoid or starter. 9. Faulty operator presence switch(es). 	<ol style="list-style-type: none"> 1. Depress clutch/brake pedal. 2. Disengage attachment clutch 3. Recharge or replace battery 4. Replace fuse. 5. Clean battery terminals 6. Check all wiring. 7. Check/replace ignition switch 8. Check/replace solenoid or starter. 9. Contact an authorized service center/department.
Engine clicks but will not start	<ol style="list-style-type: none"> 1. Weak or dead battery 2. Corroded battery terminals. 3. Loose or damaged wiring. 4. Faulty solenoid or starter. 	<ol style="list-style-type: none"> 1. Recharge or replace battery 2. Clean battery terminals 3. Check all wiring. 4. Check/replace solenoid or starter.
Loss of power	<ol style="list-style-type: none"> 1. Cutting too much grass/too fast. 2. Throttle in "CHOKE" position. 3. Build-up of grass, leaves and trash under mower. 4. Dirty air filter. 5. Low oil level/dirty oil. 6. Faulty spark plug 7. Dirty fuel filter. 8. Stale or dirty fuel. 9. Water in fuel. 10. Spark plug wire loose 11. Dirty engine air screen/fins. 12. Dirty/clogged muffler 13. Loose or damaged wiring. 14. Carburetor out of adjustment. 15. Engine valves out of adjustment. 	<ol style="list-style-type: none"> 1. Set in "Higher Cut" position/reduce speed. 2. Adjust throttle control. 3. Clean underside of mower housing. 4. Clean/replace air filter. 5. Check oil level/change oil. 6. Clean and regap or change spark plug. 7. Replace fuel filter. 8. Drain fuel tank and refill with fresh gasoline. 9. Drain fuel tank and carburetor, refill tank with fresh gasoline and replace fuel filter. 10. Connect and tighten spark plug wire. 11. Clean engine air screen/fins. 12. Clean/replace muffler. 13. Check all wiring. 14. Contact an authorized service center/department. 15. Contact an authorized service center/department.
Excessive vibration	<ol style="list-style-type: none"> 1. Worn, bent or loose blade. 2. Bent blade mandrel. 3. Loose/damaged part(s) 	<ol style="list-style-type: none"> 1. Replace blade. Tighten blade bolt. 2. Replace blade mandrel. 3. Tighten loose part(s). Replace damaged parts.

TROUBLESHOOTING POINTS

PROBLEM	CAUSE	CORRECTION
Engine continues to run when operator leaves seat with attachment clutch engaged	<ol style="list-style-type: none"> 1. Faulty operator-safety presence control system. 	<ol style="list-style-type: none"> 1. Check wiring, switches and connections. If not corrected, contact an authorized service center/department.
Poor cut - uneven	<ol style="list-style-type: none"> 1. Worn, bent or loose blade. 2. Mower deck not level. 3. Buildup of grass, leaves, and trash under mower. 4. Bent blade mandrel. 5. Clogged mower deck vent holes from buildup of grass, leaves, and trash around mandrels 	<ol style="list-style-type: none"> 1. Replace blade. Tighten blade bolt. 2. Level mower deck. 3. Clean underside of mower housing. 4. Replace blade mandrel. 5. Clean around mandrels to open vent holes
Mower blades will not rotate	<ol style="list-style-type: none"> 1. Obstruction in clutch mechanism. 2. Worn/damaged mower drive belt 3. Frozen idler pulley. 4. Frozen blade mandrel. 	<ol style="list-style-type: none"> 1. Remove obstruction. 2. Replace mower drive belt. 3. Replace idler pulley. 4. Replace blade mandrel.
Poor grass discharge	<ol style="list-style-type: none"> 1. Engine speed too slow. 2. Travel speed too fast. 3. Wet grass. 4. Mower deck not level. 5. Low/uneven tire air pressure. 6. Worn, bent or loose blade. 7. Buildup of grass, leaves and trash under mower. 8. Mower drive belt worn. 9. Blades improperly installed. 10. Improper blades used. 11. Clogged mower deck vent holes from buildup of grass, leaves, and trash around mandrels 	<ol style="list-style-type: none"> 1. Place throttle control in "FAST" position. 2. Shift to slower speed. 3. Allow grass to dry before mowing. 4. Level mower deck. 5. Check tires for proper air pressure. 6. Replace/sharpen blade. Tighten blade bolt. 7. Clean underside of mower housing. 8. Replace mower drive belt. 9. Reinstall blades sharp edge down. 10. Replace with blades listed in this manual. 11. Clean around mandrels to open vent holes
Headlight(s) not working (if so equipped)	<ol style="list-style-type: none"> 1. Switch is "OFF". 2. Bulb(s) burned out. 3. Faulty light switch. 4. Loose or damaged wiring. 5. Blown fuse. 	<ol style="list-style-type: none"> 1. Turn switch "ON". 2. Replace bulb(s). 3. Check/replace light switch. 4. Check wiring and connections. 5. Replace fuse.
Battery will not charge	<ol style="list-style-type: none"> 1. Bad battery cell(s). 2. Poor cable connections. 3. Faulty regulator (if so equipped). 4. Faulty alternator. 	<ol style="list-style-type: none"> 1. Replace battery. 2. Check/clean all connections. 3. Replace regulator. 4. Replace alternator.
Engine "backfires" when turning engine "OFF"	<ol style="list-style-type: none"> 1. Engine throttle control not set at "SLOW" position for 30 seconds before stopping engine. 	<ol style="list-style-type: none"> 1. Move throttle control to "SLOW" position and allow to idle for 30 seconds before stopping engine

SERVICE NOTES

TRACTOR - - MODEL NUMBER 917.256501

SCHEMATIC

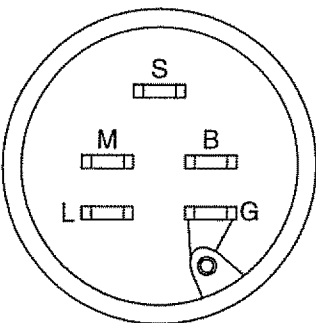
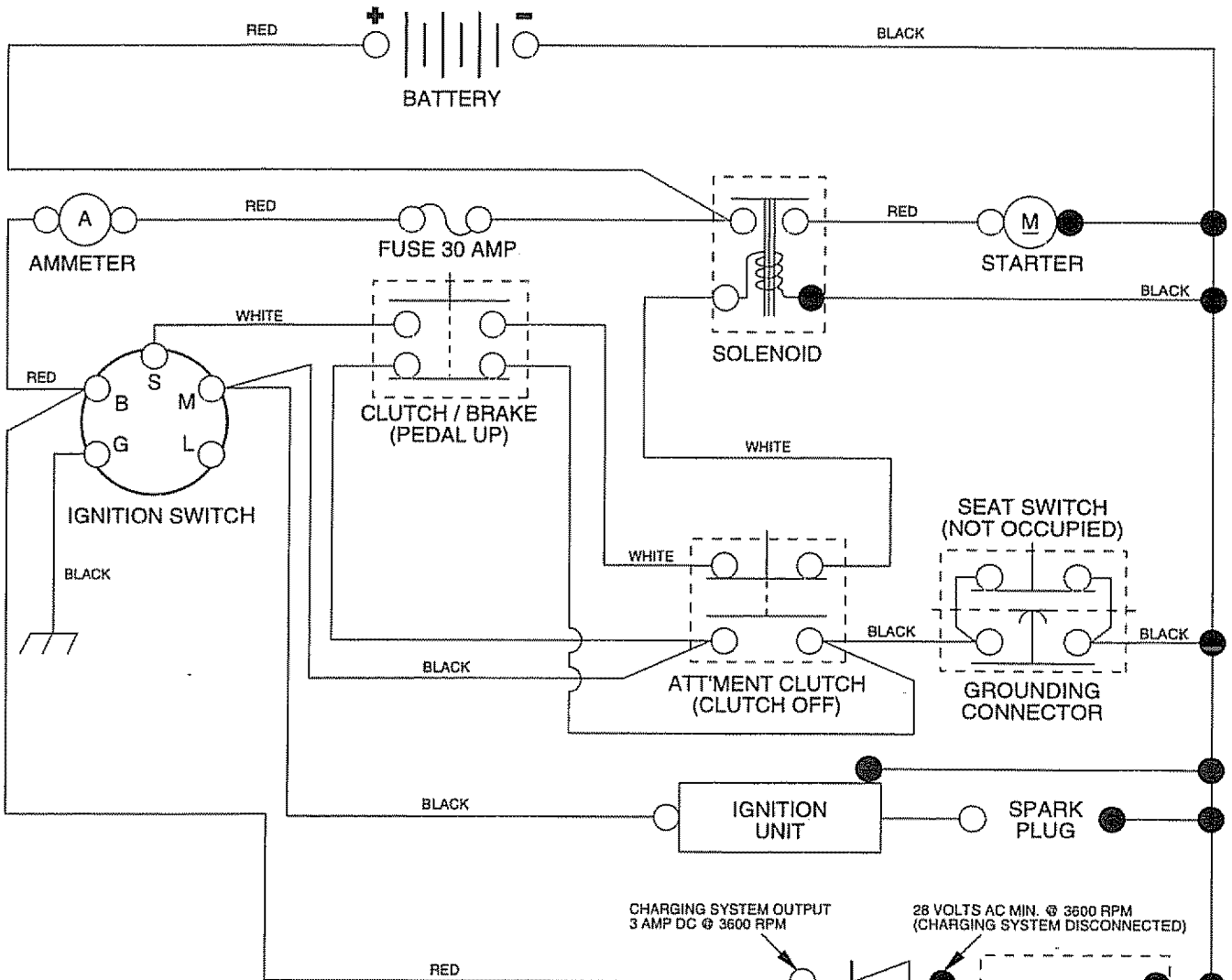

IGNITION SWITCH

POSITION	CIRCUIT
OFF	M + G
ON	B + L
START	B + S + L

NOTE
 YOUR TRACTOR IS EQUIPPED WITH A SPECIAL ALTERNATOR SYSTEM. THE LIGHTS ARE NOT CONNECTED TO THE BATTERY, BUT HAVE THEIR OWN ELECTRICAL SOURCE. BECAUSE OF THIS, THE BRIGHTNESS OF THE LIGHTS WILL CHANGE WITH ENGINE SPEED. AT IDLE THE LIGHTS WILL DIM. AS THE ENGINE IS SPEEDED UP, THE LIGHTS WILL BECOME THEIR BRIGHTEST.

WIRING INSULATED CLIPS
NOTE: IF WIRING INSULATED CLIPS WERE REMOVED FOR SERVICING OF UNIT, THEY SHOULD BE REPLACED TO PROPERLY SECURE YOUR WIRING.

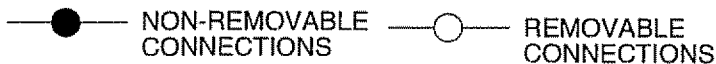

REPAIR PARTS

TRACTOR -- MODEL NUMBER 917.256501

ELECTRICAL

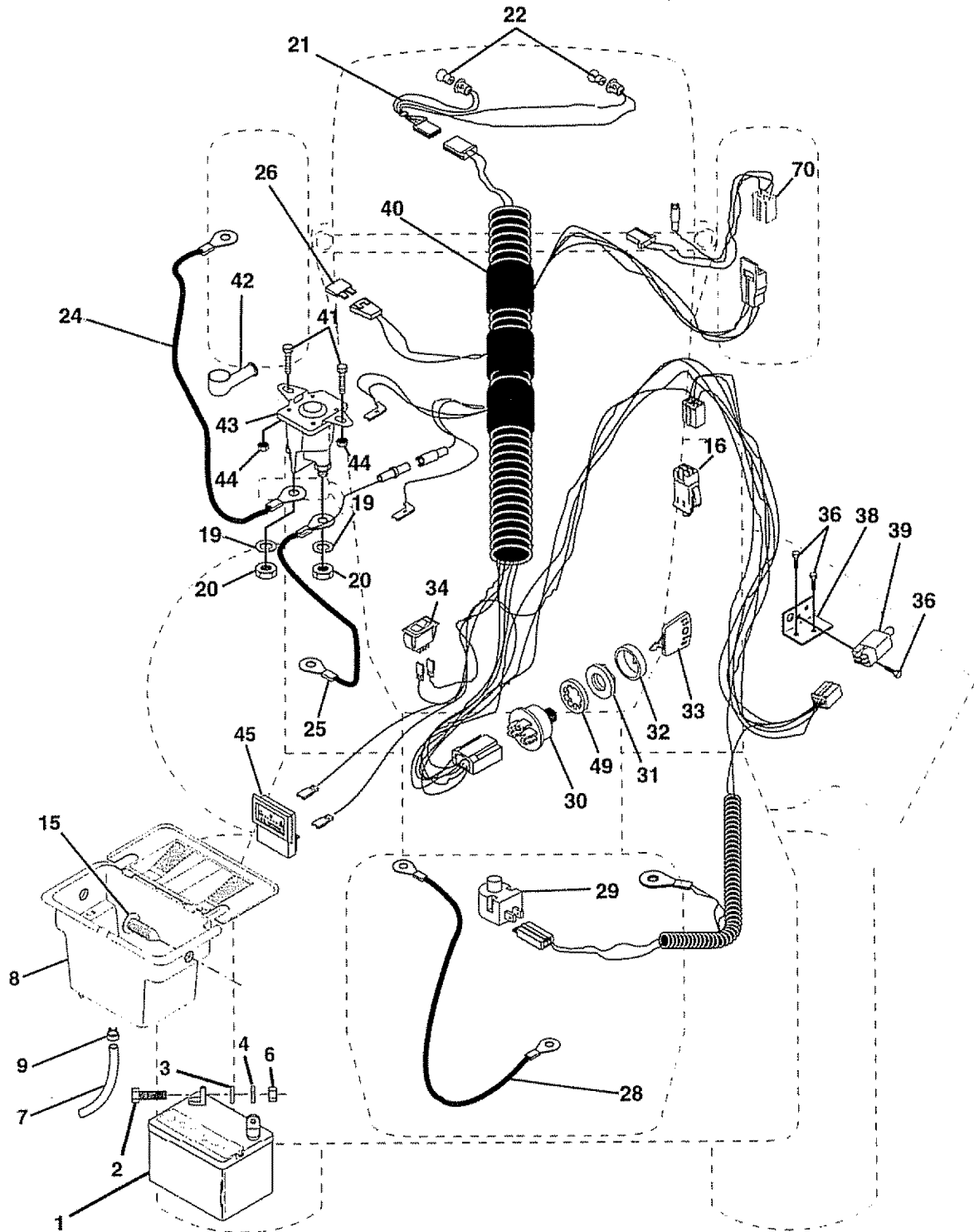

REPAIR PARTS

TRACTOR - - MODEL NUMBER 917.256501

ELECTRICAL

KEY NO.	PART NO.	DESCRIPTION
1	146139	Battery 12 Volt 25 AMP
2	74760412	Bolt Hex Hd 1/4-20unc X 3/4
3	STD551025	Washer 9/32 X 5/8 X 16 Ga
4	STD551125	Washer Lock Hvy Helical 1/4
6	STD541025	Nut Fin Hex 1/4-20 Unc
7	109238X	Tube Plastic 12"
8	144940	Case Battery
9	109596X	Clamp Hose Olive
15	147688	Fastner Snap-In
16	153664	Switch Interlock Push-In
19	STD551125	Washer Lock 1/4
20	73350400	Nut Jam Hex 1/4-20 Unc
21	136850	Harness Socket Light W/4152J
22	4152J	Bulb Light #1156
24	4799J	Cable Battery 6ga 11" red
25	146147	Cable Battery 6 Ga W/16 Wir red
26	108824X	Fuse 30 AMP Auto Green
28	4207J	Cable Ground 6ga 12" black
29	121305X	Switch Plunger Nc Gray
30	144921	Switch Ign 3 pos
31	140400	Nut Ignition
32	141226	Cover Sw Ignition
33	140403	Key Ign Molded Craftsman, Delta
34	110712X	Switch Light Blk Blk Red
36	STD601005	Screw Tap Hex #10-24unc X 1/2
38	140336	Bracket Switch Interlock
39	109553X	Switch Intlk CI MWR Gry 4 Term
40	146057	Harness Ign Dash LT 1 PC Mech 95
41	71110408	Bolt Blk Hex 1/4-20unc x 1/2
42	131563	Cover Terminal Red
43	145673	Solenoid
44	73640400	Nut Keps Blk Hex 1/4-20 Unc
45	121433X	Ammeter Rectangular 6 AMP
49	153249	Washer Pinned Delta
70	140413	Harness Engine, B&S/Tec, Dual

NOTE: All component dimensions given in U.S. inches
1 inch = 25.4 mm

REPAIR PARTS

TRACTOR -- MODEL NUMBER 917.256501

CHASSIS AND ENCLOSURES

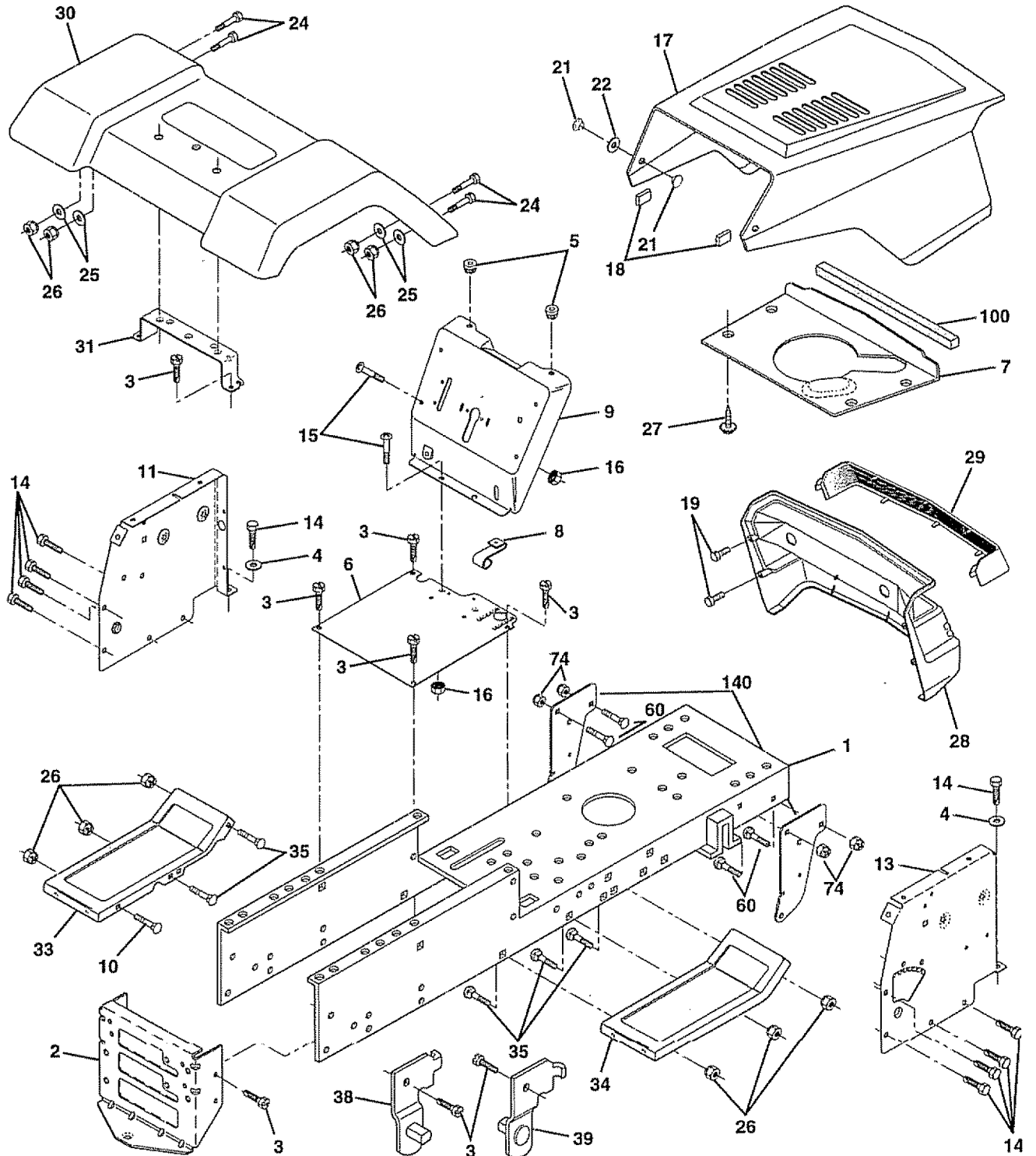

REPAIR PARTS

TRACTOR - - MODEL NUMBER 917.256501

CHASSIS AND ENCLOSURES

KEY NO.	PART NO.	DESCRIPTION
1	151169	Chassis Widmt 11ga
2	140356	Drawbar Stretch
3	17490612	Screw Thdrol 3/8-16 x 3/4 Ty-tt
4	STD551025	Washer 13/32 X 3/4 X 16 Ga
5	146077	Bumper Snap-In
6	145208X016	Saddle Slkscr Fit Sdl 65 D4360
7	126842X	Shield Ht. Hood Koh/Dia Engine
8	126471X	Clip Insulator 406 Mtg Hole
9	146760X011	Dash Slkscr 1-pc
10	STD533710	Bolt Rdhd Sqnk 3/8-16unc X 1
11	146956	Panel Dash LH
13	146961X012	Panel Slkscr Dash RH
14	17490608	Screw Thdrol 3/8-16 x 1/2 Ty-tt
15	74180512	Screw Mach TRHD 5/16-18 unc x 3/4
16	STD541431	Nut Keps 5/16-18 Unc
17	131445X574	Hood Asm Pnt Slope Weld Ms-459
18	126938X	Bumper Hood
19	17521312	Screw Sltd Hex Hd W/Pl Washer
21	122933X	Rivet Ratchet Nylon
22	124479X	Washer Nylon Blk 28 x 75 x 19
24	STD523710	Bolt Fin Hex 3/8-16 unc x 1 Gr. 5
25	19131312	Washer 13/32 X 13/16 x 12 Ga
26	STD541437	Nut Hex Lock W/Ins. 3/8-16 Unc
27	17030814	Screw Spiderloc Hex Hd #8 x 7/8
28	140137	Grille Grey
29	124029X	Lens Headlight Bar Clear
30	109872X574	Fender Pnt LT W/o Shift
31	136619	Bracket Fender Repl 109873x
33	145244X574	Footrest Pnt Lh
34	145243X574	Footrest Pnt Rh
35	STD533707	Bolt Rdhd Sht Sqnk 3/8-16 x 3/4
38	139886	Bracket Asm Pvt LH MWR Rear
39	139887	Bracket Asm Pvt RH MWR Rear
60	72140606	Bolt Rdhd Sqnk 3/8-16unc x 3/4
74	73680600	Nut Crownlock 3/8-16 UNC
100	105037X	Strip Foam 18"
140	150556	Bracket Chassis Front 7 Ga.
--	5479J	Plug Button Blk 359 Dia Choke

NOTE: All component dimensions given in U.S. inches
1 inch = 25.4 mm

REPAIR PARTS

TRACTOR - - MODEL NUMBER 917.256501

DRIVE

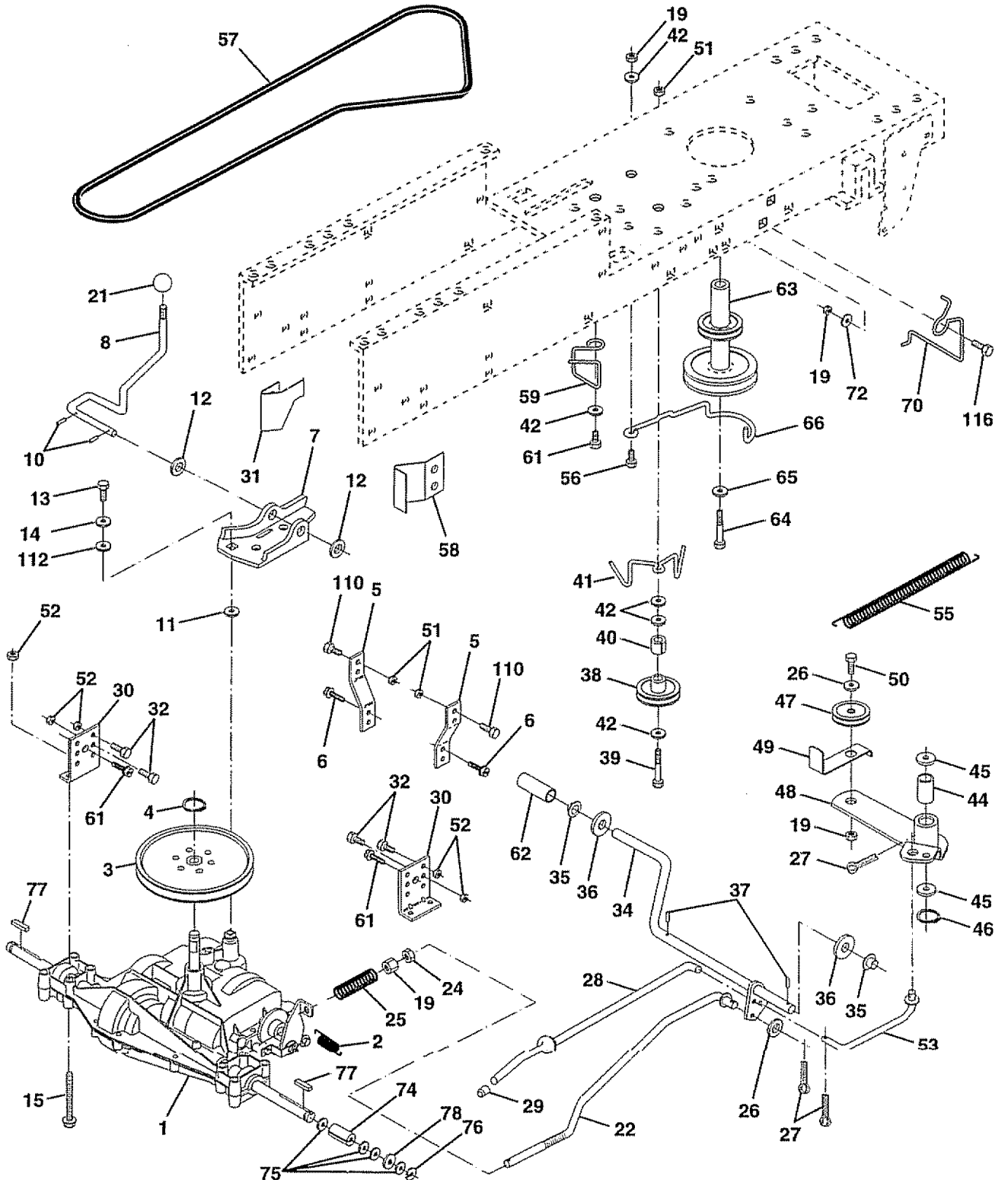

REPAIR PARTS

TRACTOR - - MODEL NUMBER 917.256501

DRIVE

KEY NO.	PART NO.	DESCRIPTION	KEY NO.	PART NO.	DESCRIPTION
1	142603	Transaxle 6sp Std D4360-79	42	19131312	Washer 13/32 X 13/16 X 12 Ga
2	146682	Spring Return Brake T/a Zinc	44	105706X	Bearing Nyl 503 X 628 X 1 25
3	123666X	Pulley Transaxle 18/20" tires	45	110812X	Washer Hardened
4	12000028	Ring Retainer # 5100-62	46	12000039	Ring Klip #t5304-50
5	121520X	Strap Torque 30 Degrees	47	127783	Pulley Idler V Groove Plastic
6	17490512	Screw Thdrol 5/16-18 X 3/4 TYT	48	123789X	Bellcrank Asm Clutch
7	130802	Bracket Saddle Shift T/a	49	123205X	Retainer Belt Style Spring
8	131679	Rod Shf Sdl LY/YT Str Blk Zinc	50	STD523715	Bolt Hex Hd 3/8-16unc X 1-1/2
10	STD561210	Pin Cotter 1/8 X 1 Cad	51	STD541237	Nut Crownlock 3/8-16 UNC
11	105701X	Washer Plate Shf 388 Sq Hole	52	STD541431	Nut Crown Lock 5/16-18
12	19151216	Washer 15/32 X 3/4 X 16ga	53	105710X	Link Clutch 7 66
13	74550412	Bolt 1/4-28unf Gr8 W/Patch	55	105709X	Spring Return Clutch 6 75
14	STD551125	Washer Lock Hvy Helical 1/4	56	STD523712	Bolt Fin Hex 3/8-16 unc x 1-1/4
15	74490544	Bolt Hex FLGHD5/16-18Gr.5	57	130801	V-Belt Gd Drive 95 25
19	STD541437	Nut Lock Hex W/Ins. 3/8-16 Unc	58	127274X	Keeper Belt RH LT Pnt/zinc 16g
21	106933X	Knob Rd 1/2-13 Plstc Thds Blk	59	140312	Keeper Belt Centerspan
22	130804	Rod Brake Blk Zinc 26 840	61	17490612	Screw Thdrol 3/8-16x3/4 Ty-tt
24	STD541237	Nut Hex Jam 3/8-16 Unc	62	8883R	Cover Pedal Blk Round
25	106888X	Spring Rod Brake 2 00 Zinc	63	140186	Pulley Eng Cl Mech 38deg LT/YT
26	STD551037	Washer 13/32 X 13/16 X 16 Ga	64	71170764	Bolt Hex 7/16-20x4 Gr 5
27	STD561210	Pin Cotter 1/8 X 3/4 Cad	65	STD551143	Washer Lock Hvy Hlcl Spr 7/16
28	145204	Rod Brake Parking Lt/Yt	66	153400	Keeper Belt Engine
29	124236X	Cap Brake Parking Red	70	134683	Guide Belt Mower Drive RH
30	130807	Bracket Mtg Transaxle	72	19132012	Washer 13/32 X 1-1/4 X 12 Ga
31	127275X	Keeper Belt LH LT 14 Ga	74	109502X	Spacer Split 80x1 94 Cad/zinc
32	STD523107	Bolt Hex Hd 5/16-18unc X 3/4	75	121749X	Washer 25/32 X 1 1/4 X 16 Ga
34	151128	Shaft Asm Pedal Foot	76	STD581075	E-ring #5133-75
35	120183X	Bearing Nylon Blk 629 Id	77	123583X	Key Square 2 0 X 1845/ 1865
36	STD551062	Washer 21/32 X 1 X 16 Ga	78	121748X	Washer 25/32 X 1-5/8 X 16ga
37	1572H	Pin Roll 3/16 X 1"	110	74760612	Bolt Fin Hex 3/8-16unc x 3/4
38	123674X	Pulley Idler Flat	112	19091210	Washer 9/32 X 3/4 X 10 Ga
39	STD523727	Bolt Fin Hex 3/8-16unc X 2-3/4	116	72110610	Bolt Rdhd Sq Neck 3/8-16 x 1.25
40	4470J	Spacer Split 395 X 59 Bzp			
41	153399	Keeper Belt Idler			

NOTE: All component dimensions given in U.S. inches.
1 inch = 25.4 mm

REPAIR PARTS

TRACTOR -- MODEL NUMBER 917.256501

STEERING ASSEMBLY

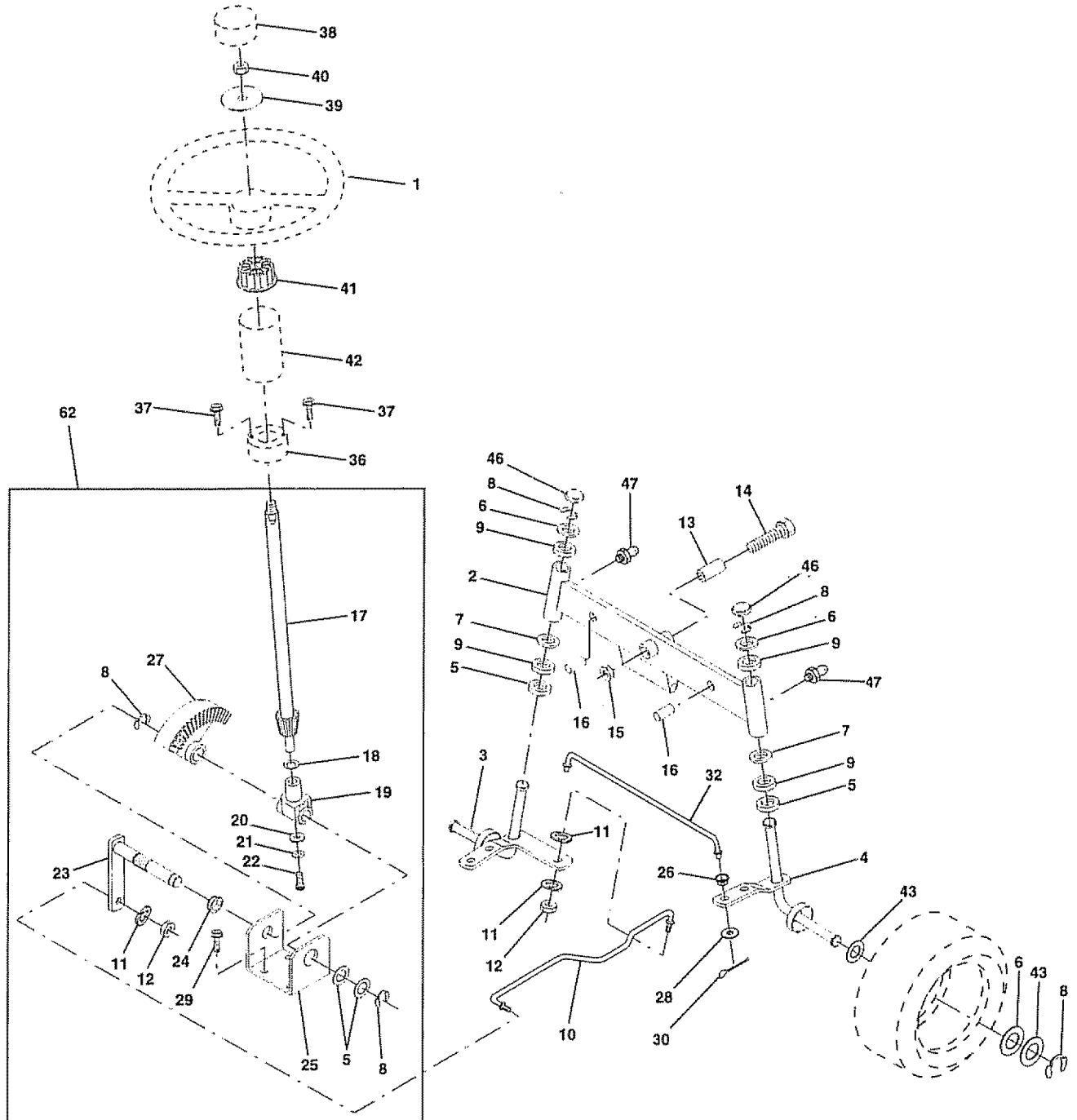

REPAIR PARTS

TRACTOR - - MODEL NUMBER 917.256501

STEERING ASSEMBLY

KEY NO.	PART NO.	DESCRIPTION
1	139768	Wheel Steering Opp Sears Blk
2	142033	Axle Asm Front Lt
3	135227	Spindle Asm Lh
4	135228	Spindle Asm Rh
5	6266H	Washer Thrust .75 x 1.230
6	121748X	Washer 25/32 x 1-5/8 x 16 Ga.
7	19272016	Washer 27/32 x 1-1/4 x 16 Ga.
8	12000029	RingKlip #T5304-75
9	3366R	Bearing Col Strg Blk
10	130468	Link Drag Sol Ball Jt 20.064
11	STD551137	Washer Lock Hvy Hlcl Spr 3/8
12	73610600	Nut Fin Hex 3/8-24 Unf
13	110438X	Spacer Bearing Axle Front
14	74011056	Bolt, Hex 5/8-11 UNC x 3-1/2
15	73901000	Locknut Flange 5/8-11 UNC
16	132624	Pin Axle 5/8 x 1.55/1.54 Lg
17	132614	Shaft Asm Strg 5/8 x 15.19 Lt
18	57079	Washer Thrust .515 x .750 x .033
19	124035X	Support Shaft
20	126684X	Washer Shim 1/4 x 5/8 x .062
21	STD551125	Washer Lock Hvy Helical 1/4
22	71100410	Screw Cap Sckt Hd Phos & Oil
23	127501	Shaft Asm Pitman
24	109816X	Nyliner Snap In
25	124036X	Bracket Steering
26	126847X	Bushing Link Drag Blk LR
27	136874	Gear Sector 22 Teeth
28	19131416	Washer 13/32 x 7/8 x 16 Ga.
29	17490612	Screw Thdrol 3/8-16 x 3/4 TY-TT
30	STD561210	Pin Cotter 1/8 x 3/4 Cad
32	130465	Rod Tie Wire Form 19.75 Mech
36	132196	Bushing Strg. 5/8 ID Dash
37	152927	Screw
38	139769	Cap Wheel Steer Opp Sears Blk
39	19133808	Washer 13/32 x 2-3/8 x 8 Ga.
40	STD541537	Locknut Center 3/8-24 Unf
41	104820X	Adaptor Wheel Strg. .640/.635 Id
42	124417X	Boot Shaft Steering Craftsman
43	121749X	Washer 25/32 x 1-1/4 x 16 Ga.
46	121232X	Cap Spindle Fr Top Blk
47	6855M	Fitting Grease
62	149684	Steering Assembly

NOTE: All component dimensions given in U.S. inches
1 inch = 25.4 mm

REPAIR PARTS

TRACTOR - - MODEL NUMBER 917.256501

ENGINE

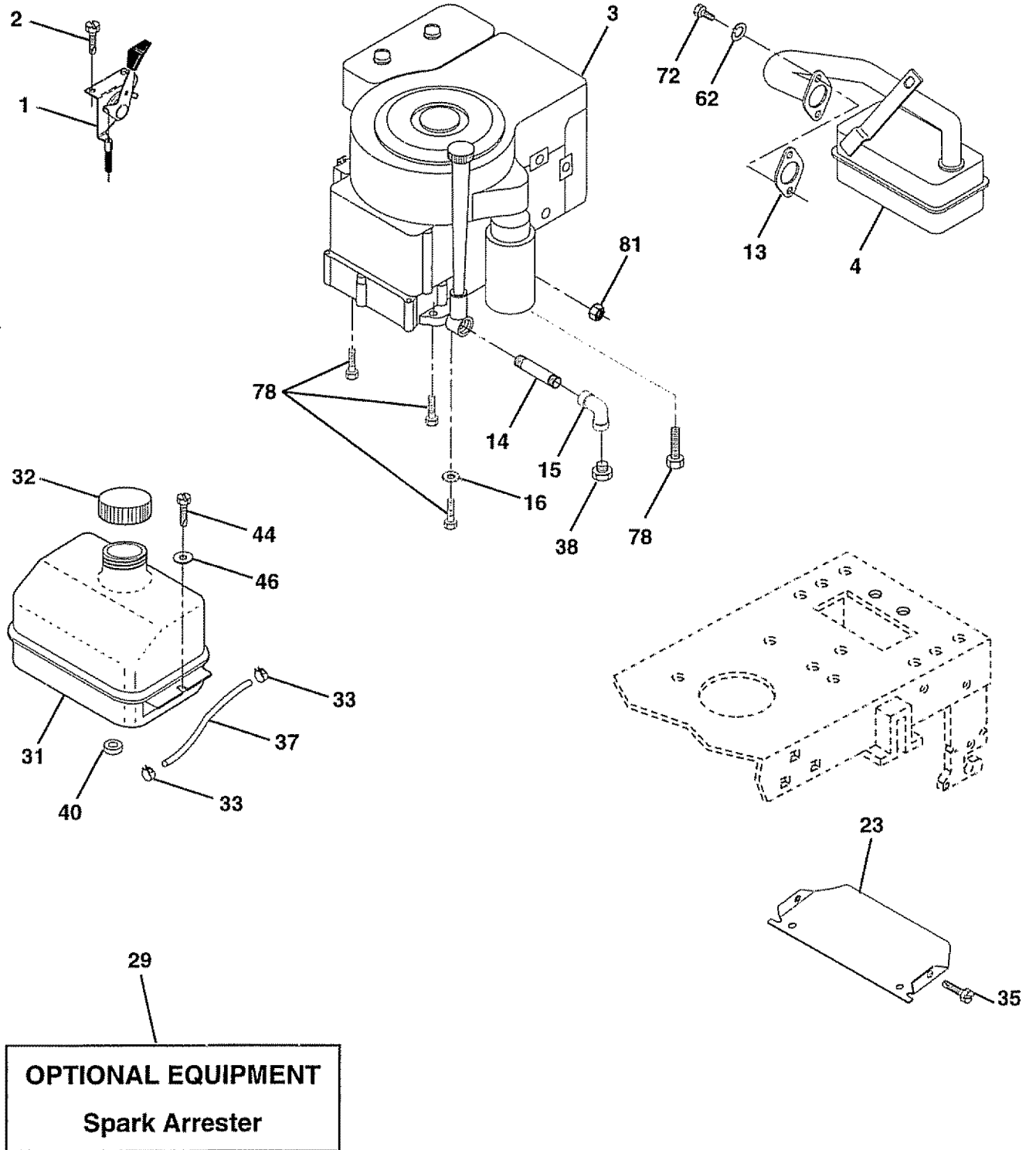

REPAIR PARTS

TRACTOR - - MODEL NUMBER 917.256501

ENGINE

KEY NO.	PART NO.	DESCRIPTION
1	132759	Control Th/ch RH Blk Pdl 15 10
2	17720410	Screw Hex Thd Cut 1/4-20x5/8 T
3	150455	Engine B&S 13.5HP IC/GOLD Model No 28R707, Type No.0140-01
4	137348	Muffler LT B&S 12/12 5/13 HP
13	272293	Gasket Eng 1 313 Id Tin Plated
14	13280324	Nipple Pipe 3/8 Npt x 3"
15	13200300	Elbow Std 90 Degree 3/8-18 Npt
16	STD551237	Washer Lock Ext Tooth 3/8
23	150554	Shield Heat Browning LT/YT
29	137180	Kit Spark Arrestor (Flat Scrn)
31	109202X	Tank Fuel Front 1 25
32	123549X	Cap Asm Fuel W/sym Vented
33	123487X	Clamp Hose Blk
35	17490512	Screw Thdrol 5/16-18 x 3/4 TYT
37	137040	Line Fuel 20"
38	-----	Plug Oil Drain (Order From Engine Manufacturer)
40	124028X	Bushing Snap Nyl Blk Fuel Line
44	17490412	Screw Hexwsh Thdrol 1/4-20 x 3/4
46	19091416	Washer 9/32 x 7/8 x 16 ga
62	STD551131	Washer Lock Hvy Hlcl Spr 5/16
72	71070512	Screw Hex Hd Cap 5/16-18 X 3/4
78	17490620	Screw Thdrol 3/8-16x1-1/4 TYTT
81	128861	Nut Flange 1/4-20 Starter Nut

NOTE: All component dimensions given in U.S. inches
1 inch = 25.4 mm

REPAIR PARTS

TRACTOR -- MODEL NUMBER 917.256501

SEAT ASSEMBLY

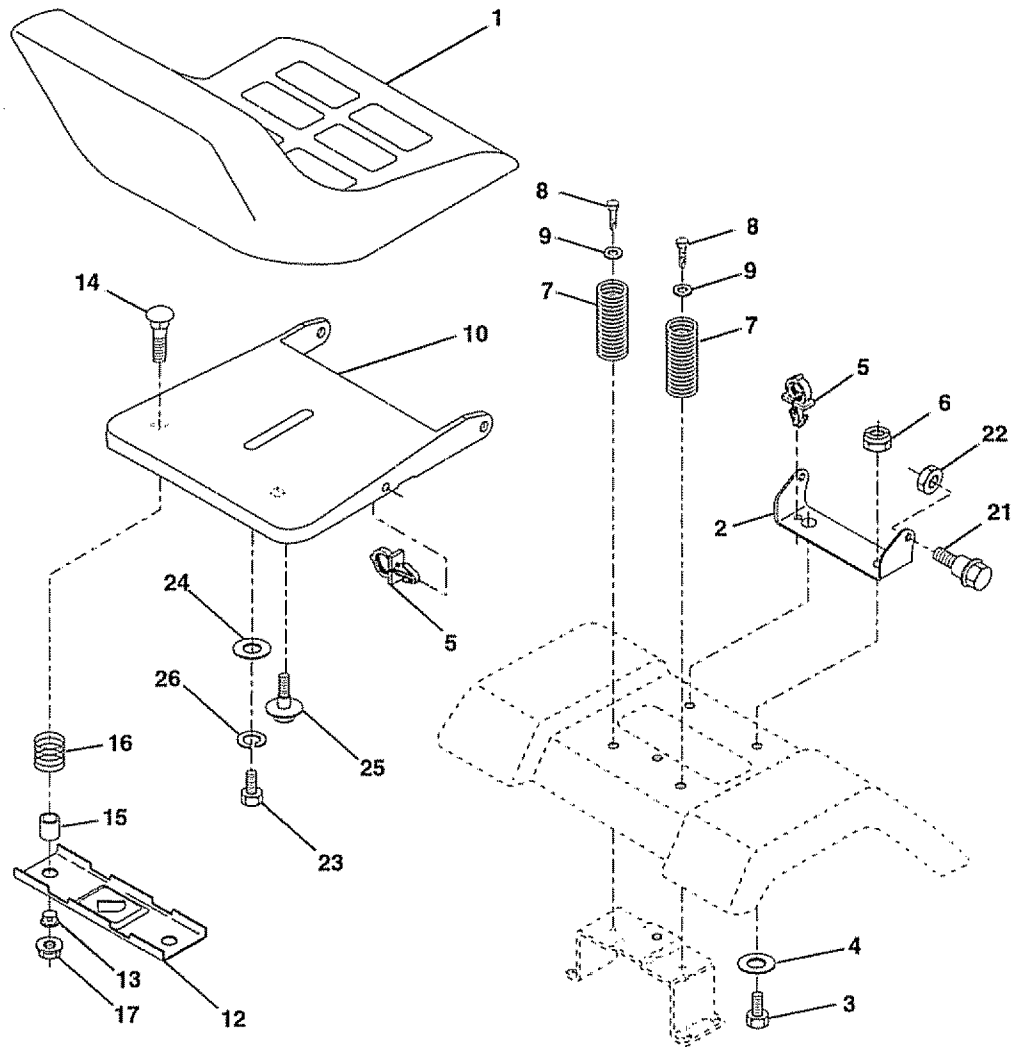

KEY NO.	PART NO.	DESCRIPTION
1	140122	Seat
2	140551	Bracket Pvt St
3	STD523710	Bolt Fin Hex 3/8-16unc X 1
4	19131610	Washer Flat 13/32 X 1 X 10 Ga
5	145006	Clip Push-In Hinged
6	STD541437	Locknut Hex W/Wsh 3/8-16
7	124181X	Spring Seat Cprsn 2 250 Blk Zi
8	17490010	Screw Thdrol 3/8-10 X 1 Ty-tt
9	19131614	Washer 13/32 X 1 X 14 Ga
10	140552	Pan Seat
12	121246X	Bracket Mounting Switch
13	121248X	Bushing Snap Blk Nyl 50 ld

KEY NO.	PART NO.	DESCRIPTION
14	72050411	Bolt Rdhd Sht Nk 1/4-20x1-3/8
15	134300	Spacer Split 28x 96 Yel Zinc
16	121250X	Spring Cprsn 1 27 Blk Pnt
17	123976X	Nut Lock 1/4 Lge Flg Gr 5 Zinc
21	153236	Bolt Shld 5/16-18 Unc
22	STD541431	Nut Lock Hex "W/Ins 5/16-18
23	74780814	Bolt Fin Hex 1/2-13 X 7/8 Gr 5
24	19171912	Washer 17/32 X 1-3/16 X 12 Ga
25	127018X	Bolt Shoulder 5/16-18 X 62
26	STD551150	Washer Lock Hvy Hchl Spr 1/2

NOTE: All component dimensions given in U.S. inches
1 inch = 25.4 mm

REPAIR PARTS

TRACTOR -- MODEL NUMBER 917.256501

DECALS

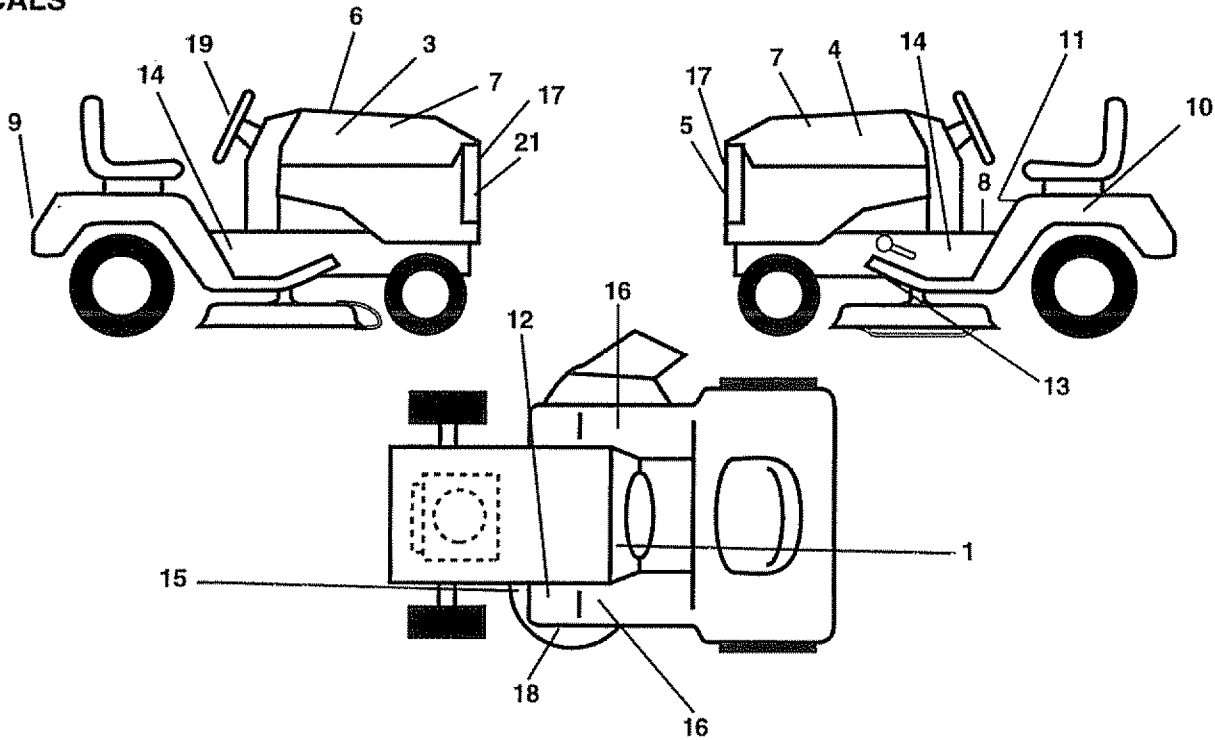

KEY NO.	PART NO.	DESCRIPTION	KEY NO.	PART NO.	DESCRIPTION
1	138955	Decal Dash Inst Oper English	13	146046	Decal V-Belt Dr Sch Tractor
3	150676	Decal Hood RH Crafts Slp LT	14	150678	Decal Chassis 6sp 42"
4	150677	Decal Hood LH Crafts Slp LT	15	136832	Decal V-Belt Sch
5	150680	Decal Grille Crafts	16	145245	Pad Footrest
6	133644	Decal Maint Cust Sears Domesti	17	150679	Decal Ins Hood
7	142235	Decal Side Pnl Icgold Blk B & S	18	133179	Decal Mower Qc System
8	140837	Decal Brake Parking Saddle	19	150333	Decal Cap CNSMR Help Line SRS
9	128314	Decal Fender Craftsman White	21	131265	Decal Lightbox
10	149516	Decal Battery Dngr/Psn Eng Acme	--	145247	Fastener Pop In
11	137537	Decal Caution Fender Eng/span	--	138311	Decal Handle Lft Height Adjust
12	4900J	Decal Clutch/brake English	--	153950	Manual Owners English
			--	153951	Manual Owners Spanish

WHEELS & TIRES

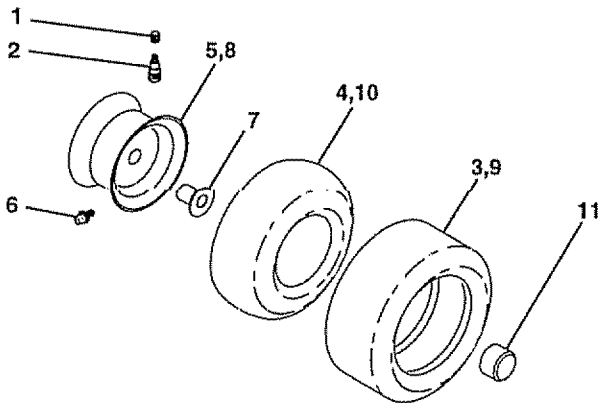

KEY NO.	PART NO.	DESCRIPTION
1	59192	Cap Valve Tire
2	65139	Stem Valve
3	106222X	Tire F Ts 15 X 6 0 - 6 Service
4	59904	Tube Front (Service Item Only)
5	106732X427	Rim Asm 6" f front White Service
6	278H	Fitting Grease (Front Wheel Only)
7	9040H	Bearing Flange (Front Wheel Only)
8	106108X427	Rim Asm 8" rear White Service
9	124635X	Tire R Ts 18x8 5-8 C Service
10	7152J	Tube Rear (Service Item Only)
11	104757X	Cap Hub Axle Blk 1 50 X 1 00
--	144334	Sealant, Tire (10 oz. Tube)

NOTE: All component dimensions given in U.S. inches
1 inch = 25.4 mm

REPAIR PARTS

TRACTOR - - MODEL NUMBER 917.256501

LIFT

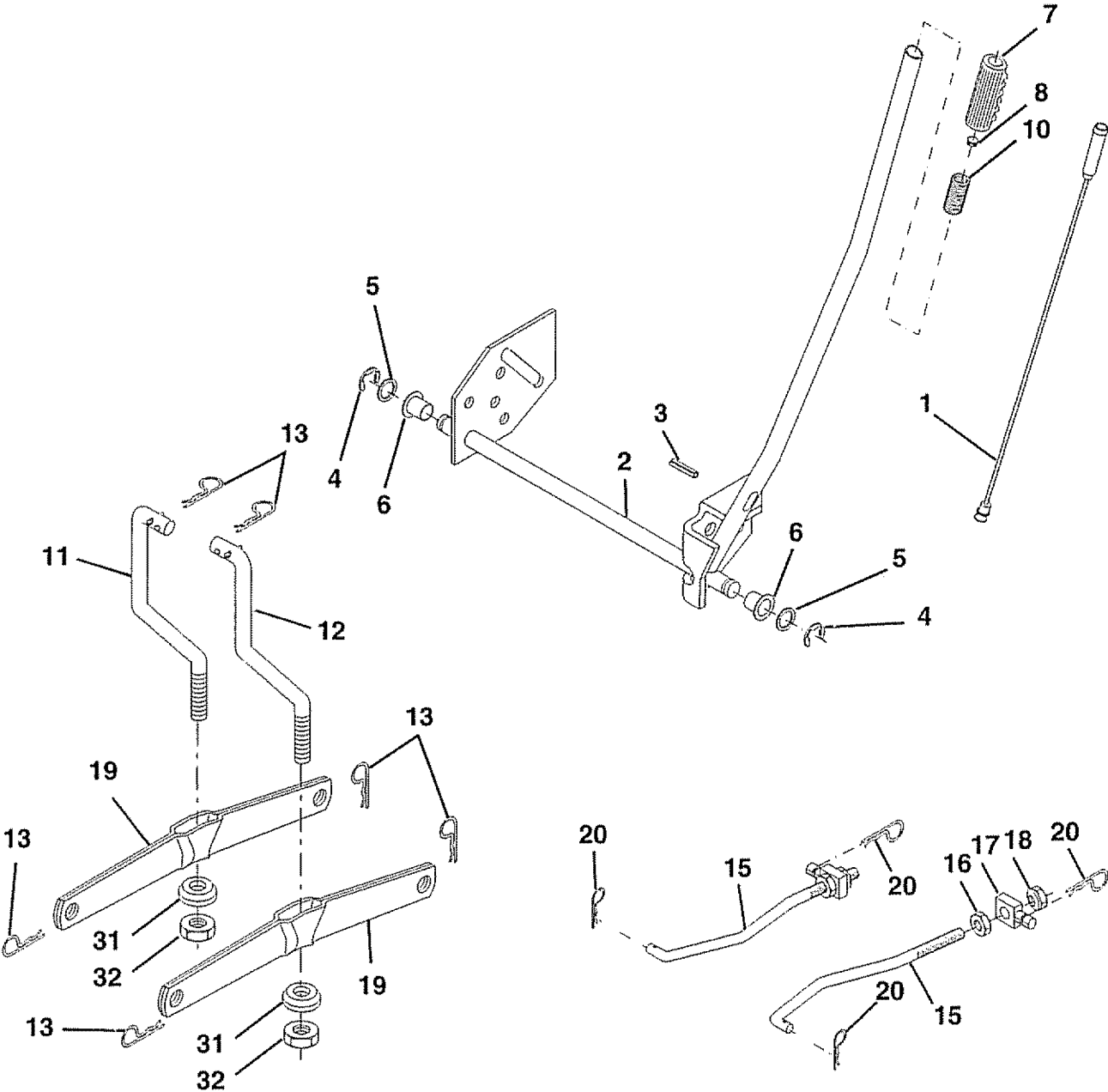

REPAIR PARTS

TRACTOR - - MODEL NUMBER 917.256501

LIFT

KEY NO.	PART NO.	DESCRIPTION
1	136973	Wire Asm Inner W/plunger 17 32
2	122507X	Shaft Asm Lift 9 680
3	105767X	Pin Groove 1 500 Zinc
4	12000002	E Ring #5133-62
5	19211621	Washer Pltd 21/32 X 1 X 21ga
6	120183X	Bearing Nylon Blk 629 Id
7	125631X	Grip Handle Fluted Blk
8	122365X	Button Plunger Red
10	122512X	Spring Cprsn 3 750 Oiled
11	139865	Link Lift LH
12	139866	Link Lift RH
13	STD624008	Retainer Spring
15	127218	Link Front
16	73350800	Nut Jam Hex 1/2-13 Unc
17	130171	Trunnion Blk Zinc
18	73800800	Nut Lock W/wsh 1/2-13unc
19	139868	Arm Suspension Rear
20	STD624008	Retainer Spring Zinc
31	140302	Bearing Pvt Lift Spherical
32	73540600	Nut Crownlock 3/8-24

NOTE: All component dimensions given in U.S. inches
1 inch = 25.4 mm

REPAIR PARTS

TRACTOR -- MODEL NUMBER 917.256501

MOWER

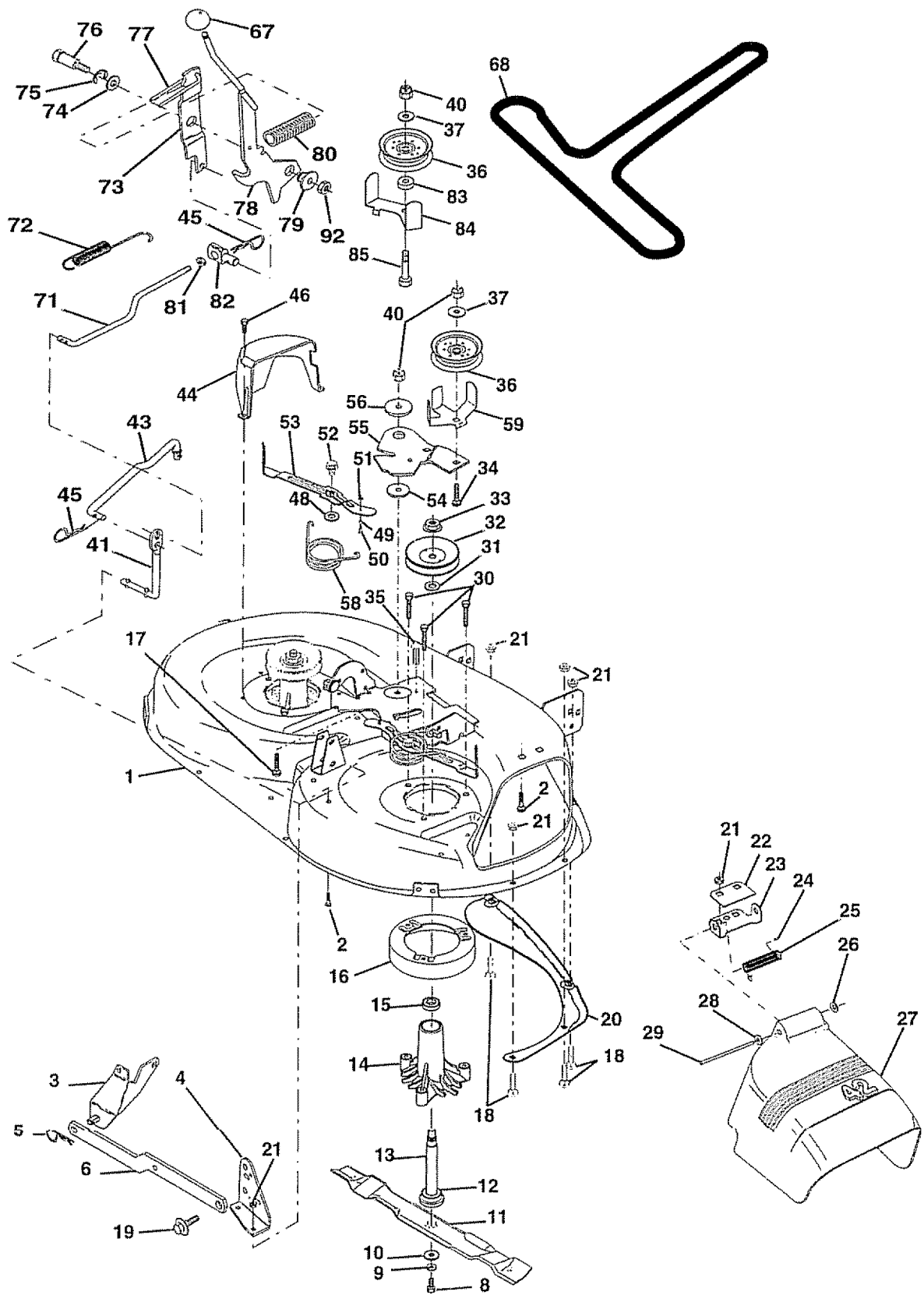

REPAIR PARTS

TRACTOR - - MODEL NUMBER 917.256501

42" MOWER

KEY NO.	PART NO.	DESCRIPTION	KEY NO.	PART NO.	DESCRIPTION
1	144393	Mower Housing	44	140088	Guard, Mandrel, L.H.
2	STD533107	Bolt	45	STD624003	Retainer
3	138017	Bracket Assembly, Sway Bar, Front	46	137729	Screw, Thd. Roll 1/4-20 x 5/8
4	138440	Bracket Assembly, Sway Bar	48	133944	Washer, Hardened
5	STD624008	Retainer Spring	49	133940	Roller Assembly, Cam Follower
6	130832	Arm, Suspension, Rear	50	131340	Bolt, Shoulder #10-24 Grade 5
8	850857	Bolt, Hex 3/8-24 x 1.25 Grade 8	51	STD541410	Locknut
9	STD551137	Washer, Lock	52	139888	Bolt, Shoulder 5/16-18 UNC
10	140296	Washer, Hardened	53	131845	Arm Assembly, Pad, Brake
11	134149	Blade, Mulching	54	133943	Washer, Hardened
12	129895	Bearing, Ball	55	140084	Arm, Idler
13	137645	Shaft Assembly, Mandrel, Vented (Includes Key Number 6)	56	122052X	Spacer, Retainer
14	128774	Housing, Mandrel, Vented	58	140086	Spring, Torsion Brakes 42"
15	110485X	Bearing, Ball, Mandrel	59	141043	Guard, Tuv Idler (94)
16	140329	Stripper, Vented Mower Deck	67	149846	Knob, Custom Oval
17	72110610	Bolt, Carriage 3/8-16 x 2-1/4	68	144200	V-Belt
18	72140505	Bolt, Carriage 5/16-18 x 5/8	71	142427	Rod, Clutch, Primary, with Nibs
19	132827	Bolt, Shoulder	72	131870	Spring, Return
20	136888	Baffle, Vortex	73	127847	Arm, Clutch, Secondary
21	STD541437	Nut, Crownlock 5/16-18 UNC	74	121748X	Washer 25/32 x 1-5/8 x 16 Gauge
22	134753	Stiffener Bracket	75	12000029	Ring, Klip
23	131267	Bracket, Deflector	76	128903	Bolt, Shoulder 3/8-16 UNC x 1.44
24	105304X	Cap, Sleeve	77	127845	Keeper, Spring
25	123713X	Spring, Torsion, Deflector	78	140334	Arm, Clutch, Primary
26	110452X	Nut, Push	79	127498	Bushing, Large, Brass
27	130968	Shield, Deflector	80	128759	Spring, Mower Clutch
28	19111016	Washer 11/32 x 5/8 x 16 Gauge	81	73350600	Nut, Hex Jam 3/8-16 UNC
29	131491	Rod, Hinge	82	142028	Trunnion Adj. 94
30	138776	Screw Thdrol Hex Head Zinc Mwr	83	120958X	Washer Sintered
31	129963	Washer, Spacer	84	144394	Keeper Belt Idler Fixed
32	153535	Pulley, Mandrel	85	72140618	Bolt Carriage 3/8-16 x 2-1/4
33	137266	Nut, Toplock, Flanged	92	STD541437	Locknut, Hex W/Wsh 3/8-16 UNC
34	STD533717	Bolt	--	130794	Mandrel Assembly (Includes Key Numbers 8-10, 12-15, 31 and 32)
35	133835	Fastner, Christmas Tree	--	145411	Mower Deck, Complete
36	131494	Pulley, Idler, Flat	Available Mulcher Plate Kit not included with tractor:		
37	STD551037	Washer 13/32 x 13/16 x 16 Ga.	--	141112	Mulcher Close-out Plate Kit
40	STD541437	Nut, Crownlock 3/8-16 UNC			
41	133551	Rod, Pivot, with Nibs			
43	140083	Rod, Clutch, Secondary, with Nibs			

NOTE: All component dimensions given in U.S. inches
1 inch = 25.4 mm.

REPAIR PARTS

TRACTOR - - MODEL NUMBER 917.256501

DANA TRANSAXLE - MODEL NUMBER 4360-79

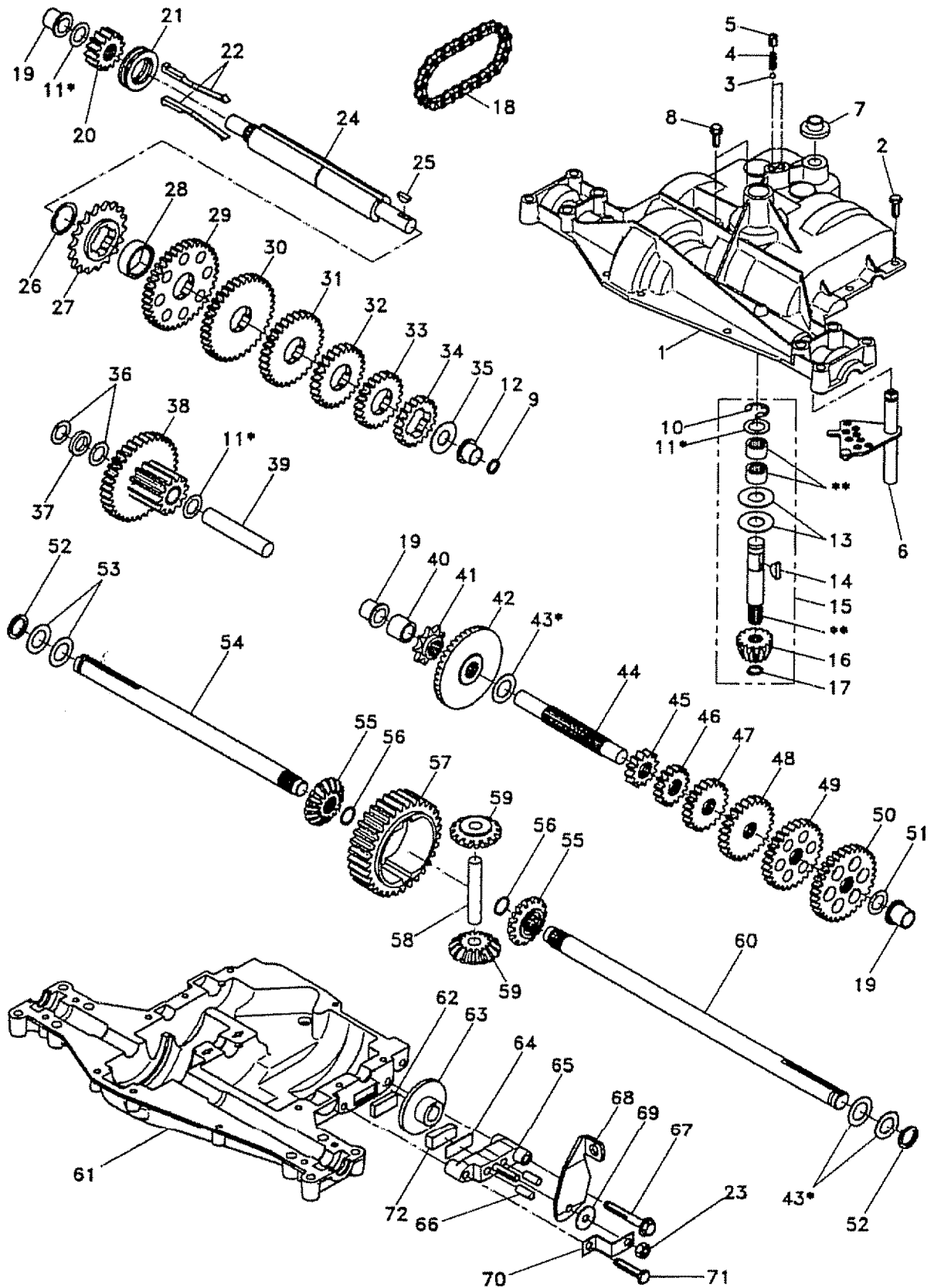

REPAIR PARTS

TRACTOR - - MODEL NUMBER 917.256501

DANA TRANSAXLE - MODEL NUMBER 4360-79

KEY PART NO.	NO.	DESCRIPTION	KEY PART NO.	NO.	DESCRIPTION
1	142671	Housing, Upper	41	105928X	Sprocket, 9 Teeth (Reverse)
2	2274J	Screw, Self-Tapping, Large 1/4-20 x .734	42	110084X	Gear, Bevel, 42 Teeth
3	134400	Ball, Detent	43	134394	* Assembly, Kit, Shim .750 Shaft
4	105904X	Spring, Detent	44	120473X	Shaft, Drive
5	105905X	Screw, Set	45	142678	Gear, Spur, 12 Teeth (1 ^a)
6	138235	Kit, Shifter Assembly	46	142679	Gear, Spur, 15 Teeth (2 ^a)
7	134399	Boot, Shifter	47	120407X	Gear, Spur, 20 Teeth (3 ^a)
8	134791	Screw, Tapping w/Sealer	48	106589X	Gear, Spur, 25 Teeth (4 ^a)
9	138241	Square Ring	49	120408X	Gear, Spur, 28 Teeth (5 ^a)
10	142672	Ring, Retaining	50	105937X	Gear, Spur, 31 Teeth (6 ^a)
11	134793	* Assembly, Kit, Shim .625 Shaft	51	2226J	Washer, Plain .632 x 1.00 x .060
12	142673	Bearing, Flange	52	134401	Washer, Neoprene
13	120415X	Washer, Plain .632 x 1.38 x .046	53	2264J	Washer, Plain .758 x 1.25 x .031
14	142674	Key, Woodruff, #9	54	120474X	Axle, L.H.
15	138234	Assembly, Kit, Input Shaft	55	110081X	Gear, Miter, 15 Teeth
16	110078X	Pinion, Bevel, 14 Teeth	56	105941X	Ring, Retaining
17	105909X	Ring, Retaining	57	110071X	Gear, Spur, 32 Teeth
18	105910X	Chain, 24 Pitches	58	120952X	Shaft, Cross
19	105911X	Bearing, Flange	59	110082X	Gear, Miter, 15 Teeth
20	142675	Gear, Spur, 14 Teeth	60	120475X	Axle, R.H.
21	138246	Collar, Clutch	61	142680	Housing, Lower
22	138236	Assembly, Kit, Clutch Keys	62	120961X	Puck, Friction
23	73810500	Locknut 5/16-24	63	7294J	Disc, Brake
24	142676	Shaft, Intermediate	64	108989X	Spacer
25	2244J	Key, Woodruff, #61	65	120953X	Jaw, Brake
26	105916X	Ring, Retaining	66	120954X	Pin, Dowel
27	120470X	Sprocket, 18 Teeth (Reverse)	67	134799	Screw, Self-Tapping, Large 5/16-18 x 2.25
28	110070X	Spacer	68	138244	Lever, Actuating
29	142677	Gear, Spur, 37 Teeth (1 ^a)	69	108996X	Washer, Plain .321 x 1.00 x .055
30	142681	Gear, Spur, 35 Teeth (2 ^a)	70	120956X	Bracket, Anti-Rotation
31	120405X	Gear, Spur, 30 Teeth (3 ^a)	71	106596X	Screw, Self-Tapping, Large 5/16-18 x 1.44
32	108980X	Gear, Spur, 25 Teeth (4 ^a)	72	120951X	Puck, Friction
33	120406X	Gear, Spur, 22 Teeth (5 ^a)	73	120416X	Grease
34	134796	Gear, Spur, 19 Teeth (6 ^a)			
35	105925X	Washer, Plain .640 x 1.37 x .061			
36	2232J	Washer, Plain .632 x 1.00 x .026			
37	108978X	Spacer .630 x 1.00 x .169			
38	110079X	Assembly, Gear, Combination of 12 Teeth and 35 Teeth			
39	124639X	Shaft, Idler			
40	120472X	Spacer .635 x .875 x .755			

* Use in combinations to maintain proper clearances

** Order Key No. 15

NOTE: All component dimensions given in U.S. inches
1 inch = 25.4 mm

REPAIR PARTS

TRACTOR - - MODEL NUMBER 917.256501

BRIGGS & STRATTON ENGINE - MODEL NUMBER 28R707, TYPE NUMBER 0140-01

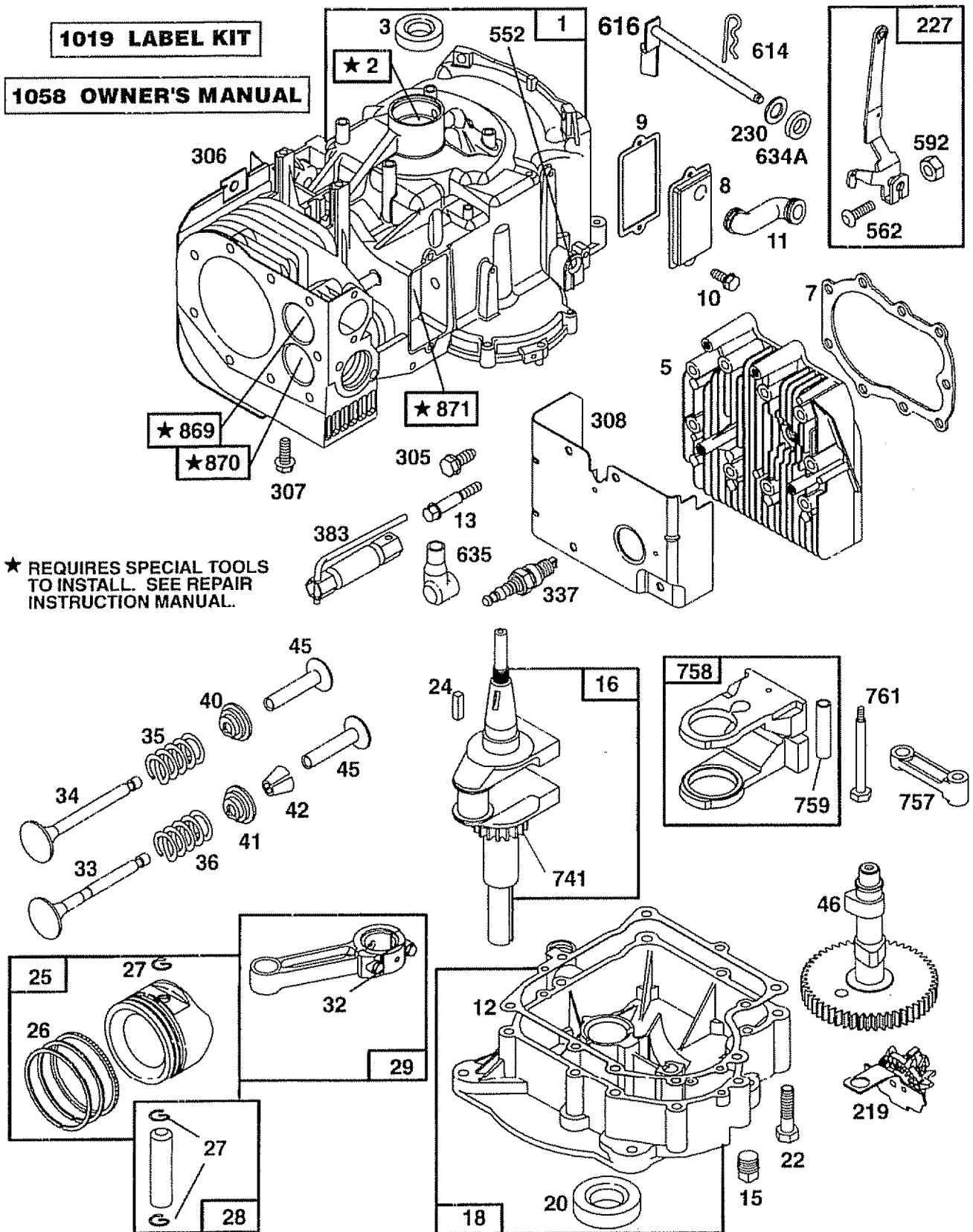

REPAIR PARTS

TRACTOR - - MODEL NUMBER 917.256501

BRIGGS & STRATTON ENGINE - MODEL NUMBER 28R707, TYPE NUMBER 0140-01

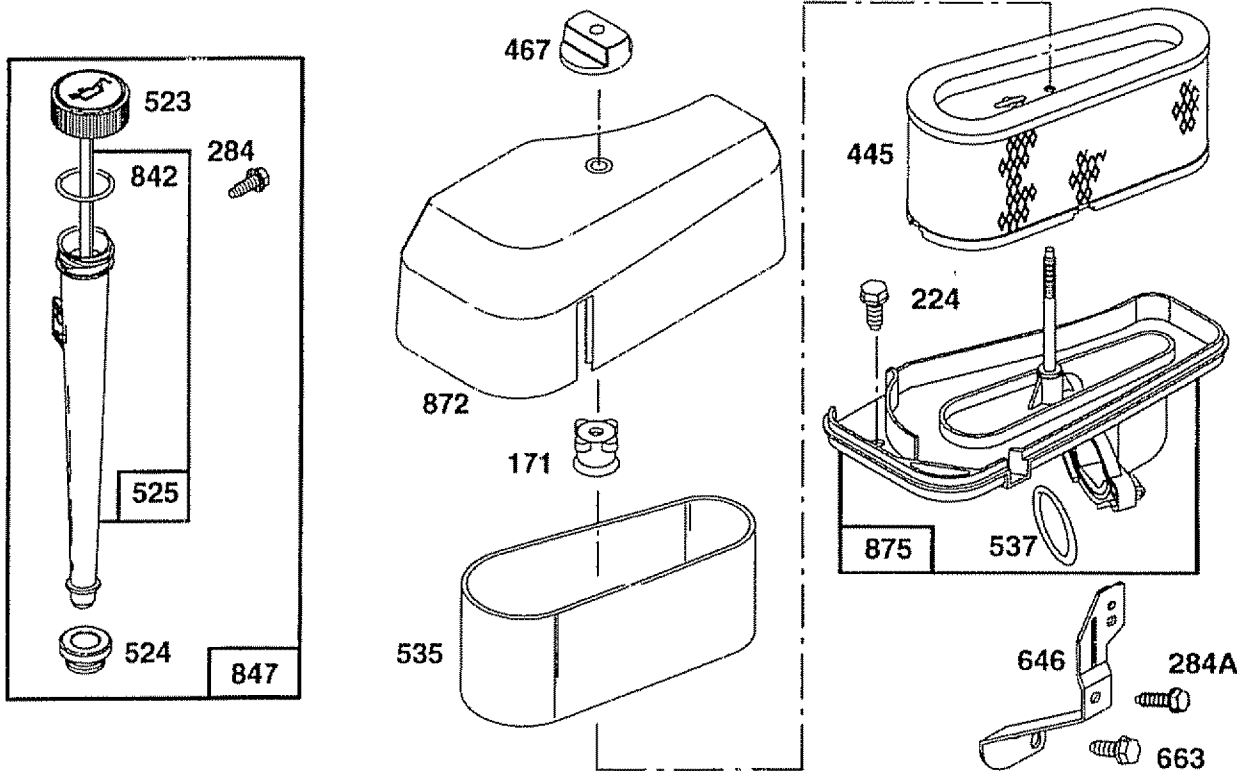
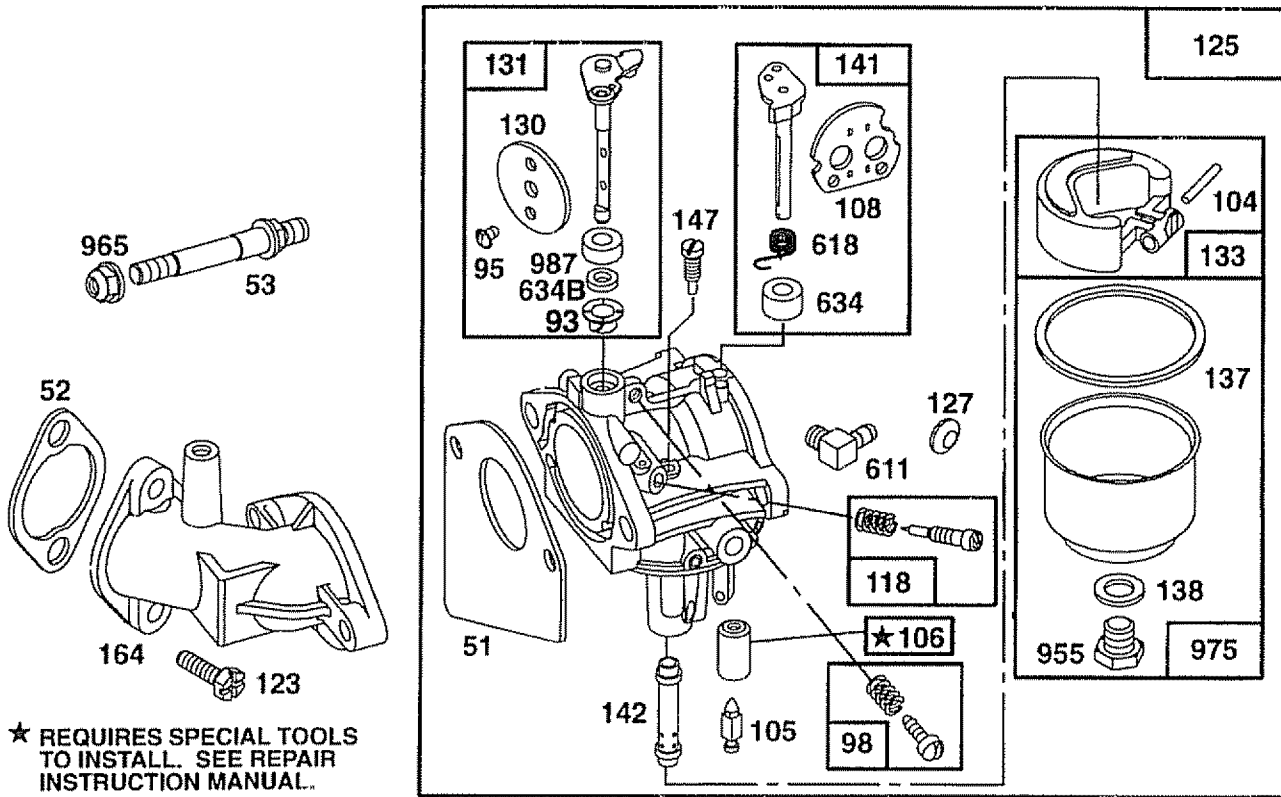

REPAIR PARTS

TRACTOR - - MODEL NUMBER 917.256501

BRIGGS & STRATTON ENGINE - MODEL NUMBER 28R707, TYPE NUMBER 0140-01

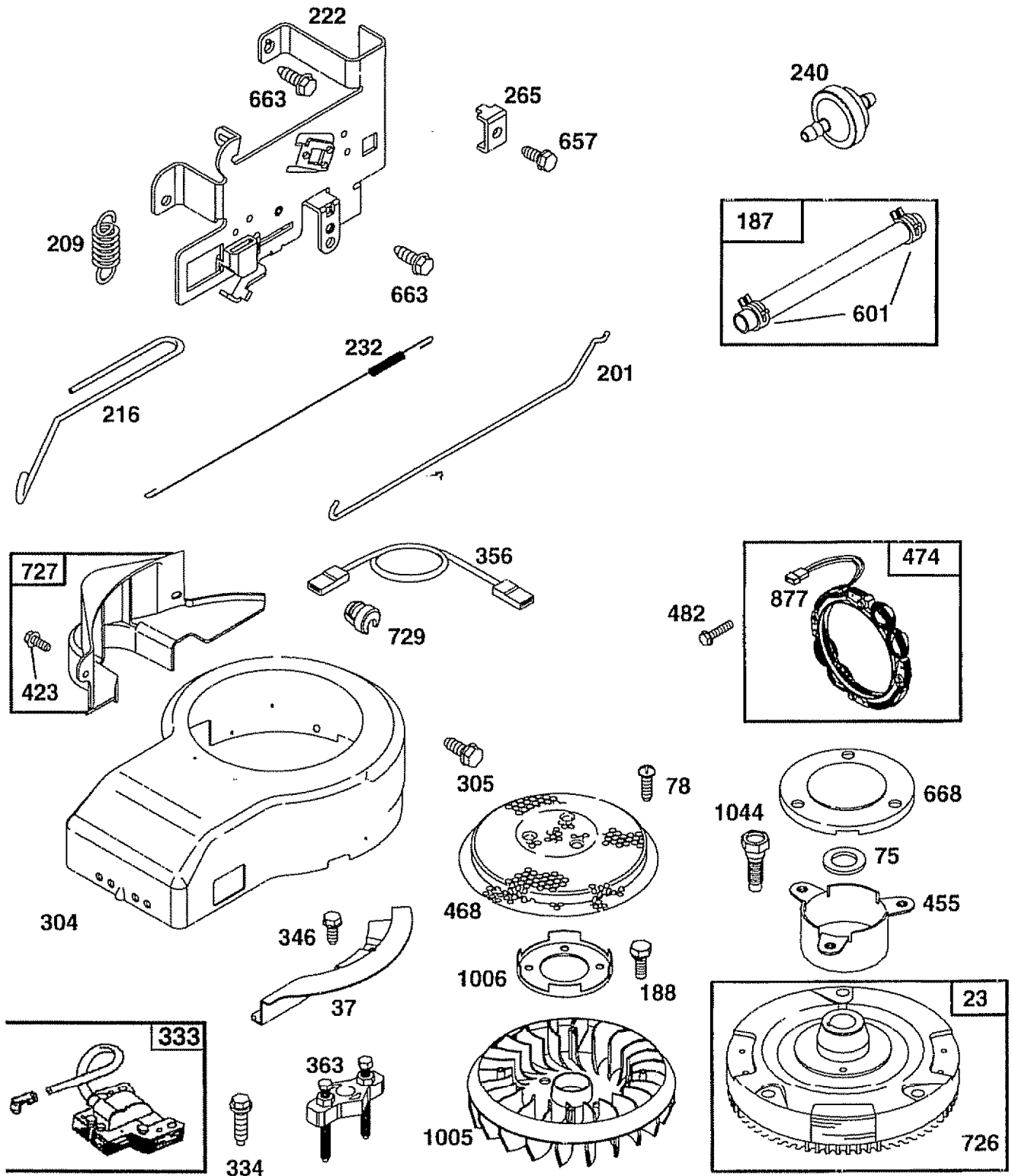

REPAIR PARTS

TRACTOR - - MODEL NUMBER 917.256501

BRIGGS & STRATTON ENGINE - MODEL NUMBER 28R707, TYPE NUMBER 0140-01

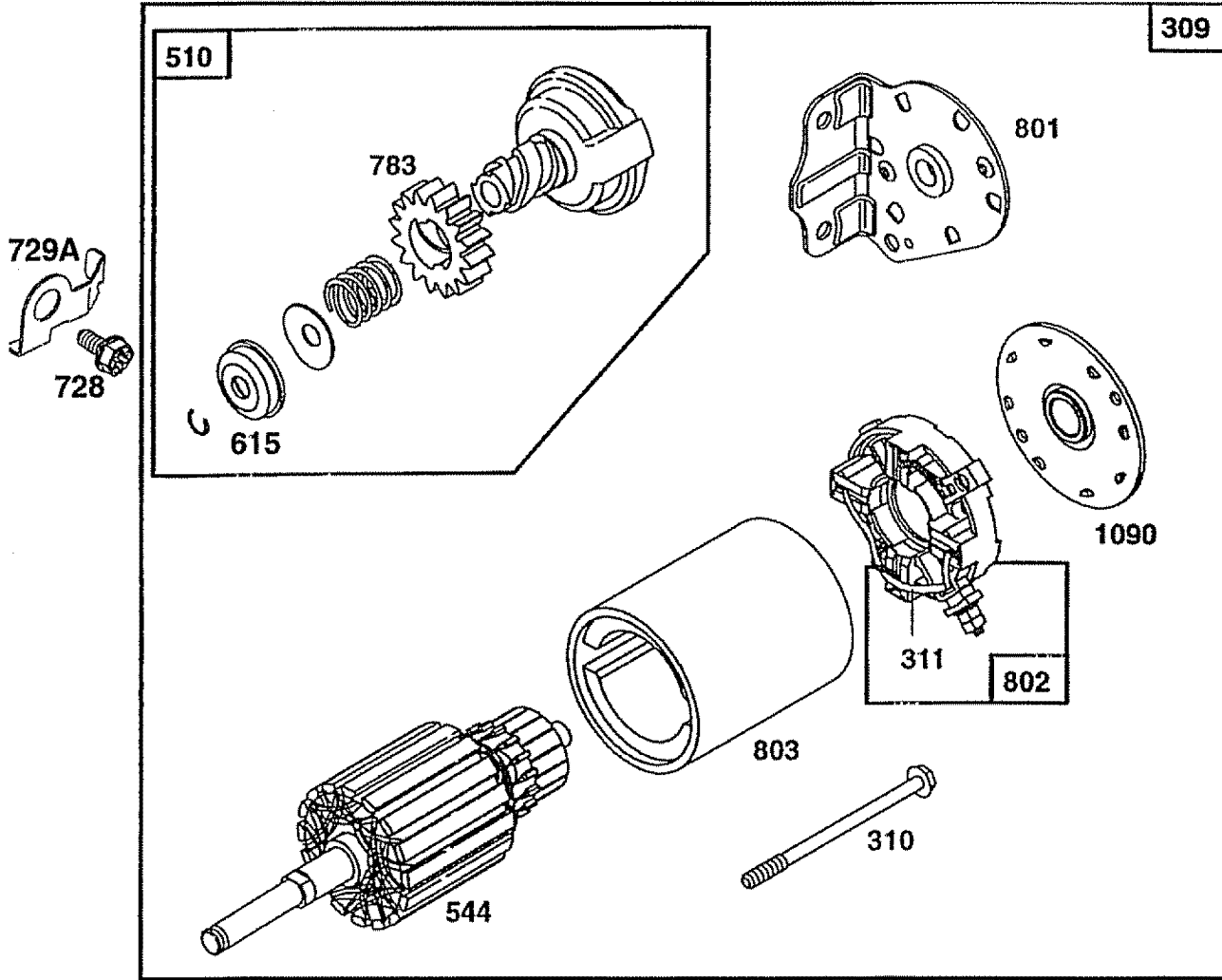

REPAIR PARTS

TRACTOR - - MODEL NUMBER 917.256501

BRIGGS & STRATTON ENGINE - MODEL NUMBER 28R707, TYPE NUMBER 0140-01

KEY PART NO. NO.	DESCRIPTION	KEY PART NO. NO.	DESCRIPTION	
1	496413	52	272554	* Gasket, Carburetor
2	399265	53	94637	Stud, Carburetor Mounting
3	391086	75	224061	Washer, Spring
5	494240	78	94626	Screw, Sems
6	22963	95	94098	** Screw, Throttle
7	271866	98	495800	Screw, Idle Adjust
8	495735	104	231789	** Pin, Float Hinge
		105	231855	** Valve, Inlet Needle
9	27803	106	231854	** Seat, Inlet
10	94621	108	224540	Valve, Choke
11	280100	118	494383	Valve, Needle
12	271916	121	497535	Carburetor Kit
	271997	123	94616	Screw, Elbow Mounting
	271996	125	495706	Carburetor
13	94622	127	- - -	** Plug, Welch (Sold in Kit Only)
15	94239	130	224539	Valve, Throttle
16	495162	131	494379	Shaft, Throttle
	94196	133	494381	Float, Carburetor
18	494238	137	281165	*** Gasket, Float Bowl
20	291675	138	281164	*** Washer, Float Bowl
22	94624	141	495931	Shaft, Choke
23	492326	142	494537	** Nozzle, Carburetor
24	222698	147	497492	** Pilot, Jet
25	394661	164	213819	Carburetor, Elbow
	394662	171	281051	Nut, Air Cleaner
	394663	187	393815	Line, Fuel (11" Long, Cut to Suit)
	394664	188	94627	Screw, Sems
26	391780	201	262767	Link, Governor
	392331	209	260871	Spring, Governor
	391781	216	262766	Link, Choke
	391782	219	490815	Gear, Governor
	391783	222	495611	Plate, Governor Control
27	260924	224	94729	Screw, Hex Head
28	299691	225	231058	Crank, Governor
	391286	227	493935	Lever Assembly, Governor
29	490348	230	94742	Washer, Governor Crank
	490469	232	262785	Spring, Governor Link
32	94671	240	394358	Filter, Fuel
33	262246	265	221535	Clamp, Casing
34	262247			
35	65906			* Included in Gasket Set (494241)
36	26828			** Included in Carburetor Kit (497535)
37	224502			*** Included in both Carburetor Kit (497535), and Carburetor Gasket Set (494385)
40	221596			
41	292260			
42	93630			
45	262248			
46	212897			
51	272465			

NOTE: All component dimensions given in U.S. inches
1 inch = 25.4 mm

REPAIR PARTS

TRACTOR - - MODEL NUMBER 917.256501

BRIGGS & STRATTON ENGINE - MODEL NUMBER 28R707, TYPE NUMBER 0140-01

KEY PART NO.	NO.	DESCRIPTION	KEY PART NO.	NO.	DESCRIPTION
284	94073	Screw, Hex Head	668	280848	Spacer
284A	94704	Screw, Hex Head	726	392134	Gear, Ring
304	496280	Housing, Blower	727	490324	Cover, Starter
305	94786	Screw, Hex Head	729	281159	Clip, Lead Wire
306	224545	Shield, Cylinder	729A	225170	Retainer, Wire
307	94623	Screw, Sems	741	262962	Gear, Timing
308	491490	Cover, Cylinder Head	757	213998	Link, Counterweight
309	497595	Motor, Starter	758	399891	Counterweight Assembly
310	497602	Thru Bolt Assembly	759	298909	Pin, Counterweight
311	497608	Brush Assembly	761	94593	Screw, Counterweight
332A	94314	Nut, Hex	783	280104	Gear
333	492341	Armature, Magneto	801	394856	Cap, Drive
334	93381	Screw, Sems	802	497605	Cap, End
337	802592	Plug, Spark	803	497604	Housing, Starter
346	93705	Screw, Hex Head	842	270920	* Seal, Cap
356	494328	Wire Assembly	847	496415	Tube Assembly, Oil
358	494241	Gasket Set	851	221798	Terminal, Ignition Cable
363	19203	Puller, Flywheel	869	261463	Seat, Intake Valve
383	89838	Wrench, Spark Plug	870	213316	Seat, Exhaust Valve
423	94073	Screw, Sems	871	261961	Guide, Exhaust Valve
445	493909	Cartridge, Air Cleaner		231218	Guide, Intake Valve, Brass
455	222561	Cup, Screen Mounting	872	281361	Cover, Air Cleaner
467	493903	Knob, Air Cleaner	875	494237	Body, Air Cleaner
468	224948	Screen, Rotating	877	393456	Diode Assembly
474	393474	Stator, Alternator	955	94642	Screw, Fuel Bowl
482	93621	Screw, Sems	965	94010	Nut, Hex
510	497606	Starter Drive Group	975	494378	Bowl, Float
523	495230	Dipstick, Oil	977	494385	Carburetor Gasket Set
524	68838	* Seal, Oil	987	281166	** Seal, Throttle Shaft
525	496113	Tube, Oil Filler	1005	281355	Fan, Flywheel
535	272403	Element, Filter	1006	224413	Retainer, Fan
537	281106	* O-Ring, Air Cleaner	1019	491252	Label Kit
544	497603	Armature, Starter	1044	94673	Screw, Hex Head
552	231597	Bushing, Governor Crank	1058	272697	Manual, Owner's
562	92613	Bolt, Governor Lever	1090	497607	Retainer, Brush
592	231082	Nut, Hex			
601	93053	Clamp, Fuel Pipe			RPM Settings: Low Speed: 1900-2100
611	494451	Elbow, Fuel Pipe			High Speed: 3000-3200
614	93306	Pin, Cotter			
615	93307	Retainer, E-Ring			* Included in Gasket Set (494241)
618	262803	Spring, Choke Return			** Included in Carburetor Kit (497535)
634	281168	** Seal, Choke Shaft			
634A	491323	* Seal, Governor			*** Included in both Carburetor Kit (497535),
634B	398970	** Washer, Throttle Shaft			and Carburetor Gasket Set (494385)
635	66538	Elbow, Spark Plug			
646	224546	Brace, Air Cleaner			
657	93496	Screw, Sems			
663	94620	Screw, Hex Head			

NOTE: All component dimensions given in U.S. inches
1 inch = 25.4 mm

SERVICE NOTES

SUGGESTED GUIDE FOR SIGHTING SLOPES FOR SAFE OPERATION

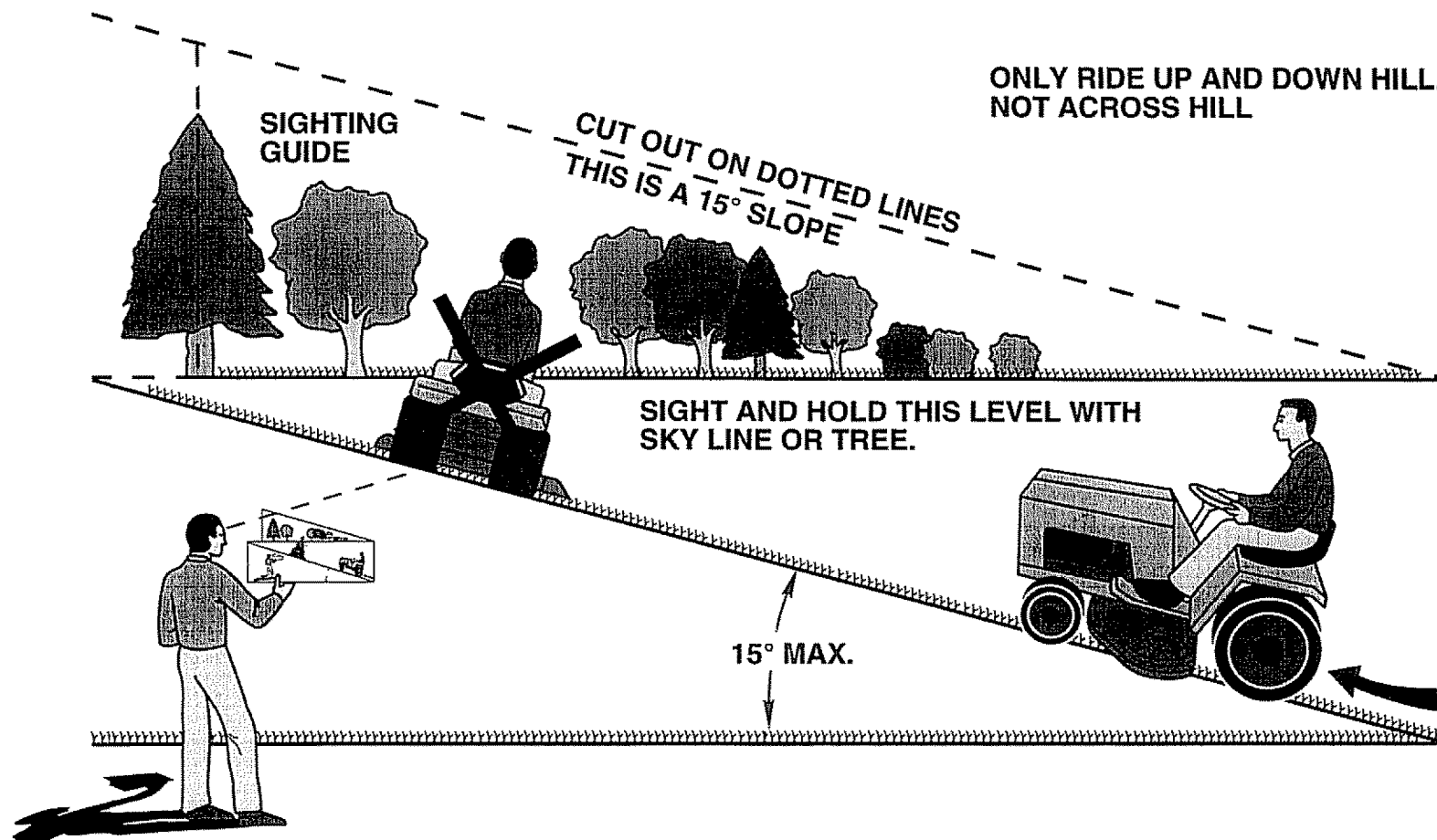

Operate your Tractor up and down the face of slopes (not greater than 15°), never across the face. Make turns gradually to prevent tipping or loss of control. Exercise extreme caution when changing direction on slopes.

SEARS

OWNER'S MANUAL

**MODEL NO.
917.256501**

IF YOU NEED REPAIR SERVICE OR PARTS:

FOR REPAIR SERVICE, CALL
THIS TOLL FREE NUMBER:

1-800-4-REPAIR
(1-800-473-7247)

FOR REPLACEMENT PARTS
INFORMATION AND
ORDERING, CALL THIS
TOLL FREE NUMBER:

1-800-FON-PART
(1-800-366-7278)

FOR CONSUMER ASSISTANCE
HOT LINE, CALL THIS
TOLL FREE NUMBER:

1-800-659-5917

CRAFTSMAN®

13.5 HP IC ELECTRIC START 42" MOWER 6 SPEED TRANSAXLE LAWN TRACTOR

Each tractor has its own model number. Each engine has its own model number.

The model number for your tractor will be found on the model plate located under the seat.

The model number for your engine will be found on the blower housing of the engine.

All parts listed herein may be ordered from any Sears, Roebuck and Co. Service Center/Department and most Retail Stores.

WHEN ORDERING REPAIR PARTS, ALWAYS GIVE THE FOLLOWING INFORMATION:

- **PRODUCT - TRACTOR**
- **MODEL NUMBER - 917.256501**
- **ENGINE MODEL NO. - 28R707, TYPE NO. 0140-01**
- **PART NUMBER**
- **PART DESCRIPTION**

Your Sears merchandise has added value when you consider Sears has service units nationwide staffed with Sears trained technicians... professional technicians specifically trained to insure that we meet our pledge to you, we service what we sell.