

Sears

*owners
manual*

**MODEL NO.
113.225801**

**BELT AND DISC
SANDER ONLY**

**MODEL NO.
113.225831**

**BELT AND DISC
SANDER/WITH
LEGS AND MOTOR**

Serial
Number _____

Model and serial
number may be found
at the right-hand side
of the base.

You should record both
model and serial number
in a safe place for
future use.

CAUTION:

**Read GENERAL and
ADDITIONAL SAFETY
INSTRUCTIONS
carefully**

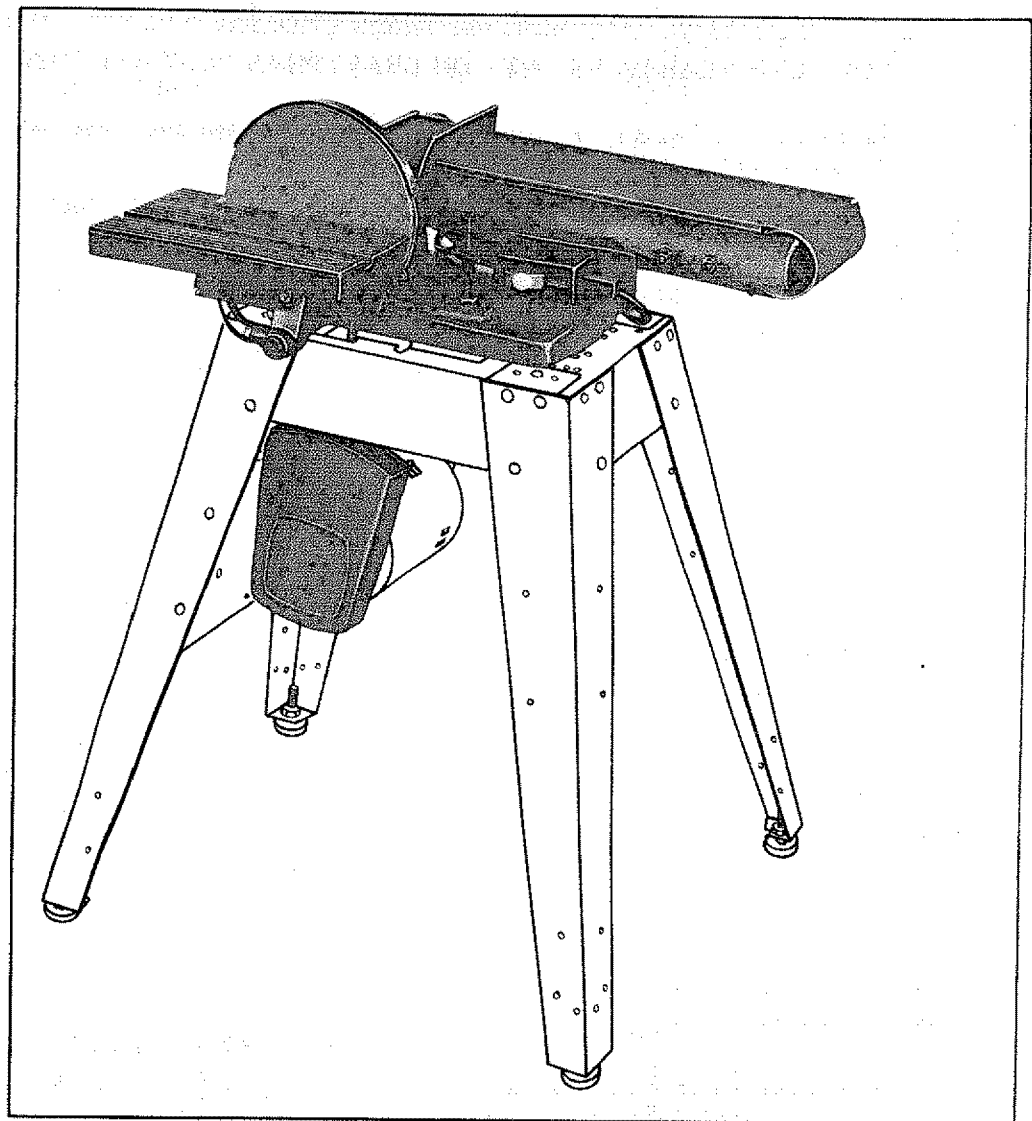

Sears

CRAFTSMAN.

BELT AND DISC SANDER

- *assembly*
- *operating*
- *repair parts*

Sold by SEARS, ROEBUCK AND CO., Chicago, IL. 60684 U.S.A.

FULL ONE YEAR WARRANTY ON CRAFTSMAN BELT AND DISC SANDER

If within one year from the date of purchase, this Craftsman Belt and Disc Sander fails due to a defect in material or workmanship, Sears will repair it, free of charge.

WARRANTY SERVICE IS AVAILABLE BY SIMPLY CONTACTING THE NEAREST SEARS STORE OR SERVICE CENTER THROUGHOUT THE UNITED STATES.

This warranty gives you specific legal rights, and you may also have other rights which vary from state to state.

SEARS, ROEBUCK AND CO., Sears Tower, BSC 41-3, Chicago, IL 60684

general safety instructions for power tools

1. KNOW YOUR POWER TOOL

Read and understand the owner's manual and labels affixed to the tool. Learn its application and limitations as well as the specific potential hazards peculiar to this tool.

2. GROUND ALL TOOLS

This tool is equipped with an approved 3-conductor cord and a 3-prong grounding type plug to fit the proper grounding type receptacle. The green conductor in the cord is the grounding wire. Never connect the green wire to a live terminal.

3. KEEP GUARDS IN PLACE

— in working order, and in proper adjustment and alignment.

4. REMOVE ADJUSTING KEYS AND WRENCHES

Form habit of checking to see that keys and adjusting wrenches are removed from tool before turning it on.

5. KEEP WORK AREA CLEAN

Cluttered areas and benches invite accidents. Floor must not be slippery due to wax or sawdust.

6. AVOID DANGEROUS ENVIRONMENT

Don't use power tools in damp or wet locations or expose them to rain. Keep work area well lighted. Provide adequate surrounding work space.

7. KEEP CHILDREN AWAY

All visitors should be kept a safe distance from work area.

8. MAKE WORKSHOP KID-PROOF

— with padlocks, master switches, or by removing starter keys.

9. DON'T FORCE TOOL

It will do the job better and safer at the rate for which it was designed.

10. USE RIGHT TOOL

Don't force tool or attachment to do a job it was not designed for.

11. WEAR PROPER APPAREL

Do not wear loose clothing, gloves, neckties or jewelry (rings, wristwatches) to get caught in moving parts. NONSLIP footwear is recommended. Wear protective hair covering to contain long hair. Roll long sleeves above the elbow.

12. USE SAFETY GOGGLES (Head Protection)

Wear safety goggles (must comply with ANSI Z87.1) at all times. Everyday eyeglasses only have impact resistant lenses, they are NOT safety glasses. Also, use face or dust

mask if cutting operation is dusty, and ear protectors (plugs or muffs) during extended periods of operation.

13. SECURE WORK

Use clamps or a vise to hold work when practical. It's safer than using your hand, frees both hands to operate tool.

14. DON'T OVERREACH

Keep proper footing and balance at all times.

15. MAINTAIN TOOLS WITH CARE

Keep tools sharp and clean for best and safest performance. Follow instructions for lubricating and changing accessories.

16. DISCONNECT TOOLS

before servicing; when changing accessories such as blades, bits, cutters, etc.

17. AVOID ACCIDENTAL STARTING

Make sure switch is in "OFF" position before plugging in.

18. USE RECOMMENDED ACCESSORIES

Consult the owner's manual for recommended accessories. Follow the instructions that accompany the accessories. The use of improper accessories may cause hazards.

19. NEVER STAND ON TOOL

Serious injury could occur if the tool is tipped or if the cutting tool is accidentally contacted.

Do not store materials above or near the tool such that it is necessary to stand on the tool to reach them.

20. CHECK DAMAGED PARTS

Before further use of the tool, a guard or other part that is damaged should be carefully checked to ensure that it will operate properly and perform its intended function. Check for alignment of moving parts, binding of moving parts, breakage of parts, mounting, and any other conditions that may affect its operation. A guard or other part that is damaged should be properly repaired or replaced.

21. DIRECTION OF FEED

Feed work into a blade or cutter against the direction of rotation of the blade or cutter only.

22. NEVER LEAVE TOOL RUNNING UNATTENDED

Turn power off. Don't leave tool until it comes to a complete stop.

additional safety instructions for belt and disc sander

Safety is a combination of operator common sense and alertness at all times when the finishing machine is being used.

WARNING: FOR YOUR OWN SAFETY, DO NOT ATTEMPT TO OPERATE YOUR FINISHING MACHINE UNTIL IT IS COMPLETELY ASSEMBLED AND INSTALLED ACCORDING TO THE INSTRUCTIONS . . . AND UNTIL YOU HAVE READ AND UNDERSTOOD THE FOLLOWING.

	PAGE
1. General Safety Instructions For Power Tools	2
2. Getting To Know Your Sander	18
3. Basic Machine Operation	21
4. Maintenance	23
5. Stability Of Machine	

If there is any tendency for the machine to tip over or move during certain operations such as when finishing long heavy boards, the sander should be bolted down.

6. Location

The machine should be positioned so neither the operator nor a casual observer is forced to stand in line with the abrasive belt or disc. This machine is intended for indoor use only.

7. Kickback

When finishing on the Disc, always apply the workpiece to the "Down Side" of the disc. Applying the workpiece to the "Up Side" could cause it to fly up (kickback) which could be hazardous.

8. Protection: Eyes, Hands, Face, Ears, Body

- Wear safety goggles that comply with ANSI Z87.1-1968, and a face shield if operation is dusty. Wear ear plugs or muffs during extended periods of operation.
- Do not finish pieces of material too small to hold by hand.
- Avoid awkward hand positions, where a sudden slip could cause a hand to move into the abrasive disc or belt.
- Never climb on the machine.
- Never turn your Sander "ON" before clearing the table(s) or work surface(s) of all objects (tools, scraps of wood, etc.) except for the workpiece and related feed or support devices for the operation planned.

- Make sure the abrasive belt runs in the right direction. Always have the tracking adjusted correctly so that the belt does not run off the pulleys.
 - Hold the work firmly when finishing on the abrasive belt and against the worktable when finishing on the disc.
 - Always adjust the worktable to within 1/16 in of the abrasive disc or belt.
 - When finishing a large piece of material, make sure it is supported at table height.
 - Never leave the machine work area with the power on, before the machine has come to a complete stop, or without removing and storing the switch key.
 - Never operate the machine with protective cover on the unused shaft end of the motor removed.
9. If any part of this belt disc sander should break, bend, or fail in any way or any electrical component fail to perform properly, or if any is missing, shut off power switch, remove power supply cord from power supply and replace damaged missing and/or failed parts before resuming operation.

10. Read and follow the instructions appearing on label on the rear of the Disc Dust Trap (Disc Housing):

<p style="text-align: center;">DANGER</p> <p style="text-align: center;">FOR YOUR OWN SAFETY</p> <ol style="list-style-type: none">READ AND UNDERSTAND OWNERS MANUAL BEFORE OPERATING MACHINE.WEAR SAFETY GOGGLES AND DUST MASK.MAINTAIN 1/16 INCH MAXIMUM CLEARANCE BETWEEN TABLE AND SANDING BELT OR DISC.AVOID "KICKBACKS" (WORKPIECE THROWN AT YOU): - DO NOT USE RIGHT HALF OF DISC.ALWAYS SUPPORT WORKPIECE WITH "BACKSTOP" OR "WORKTABLE".DO NOT ATTACH A HOME-N-SHOP VAC TO DISC HOUSING WHEN SANDING IRON OR STEEL.
--

11. Think Safety.

CAUTION: This machine is not designed for heavy deburring operations. When finishing ferrous metals, sparks will be generated and could cause a fire. Disconnect any type of dust collecting hose from the machine. Also remove all traces of wood dust that may have accumulated inside the dust traps in the machine.

additional safety instructions for belt and disc sander

WARNING: THE 2-1/2" MACHINE PULLEY AND THE 2" MOTOR PULLEY FURNISHED, WILL RUN THE DISC AT APPROXIMATELY 2700 RPM AND THE BELT AT APPROXIMATELY 2100 (FEET PER MINUTE) WHEN USED WITH A 3450 RPM MOTOR. NEVER SUBSTITUTE OR INTERCHANGE THESE PULLEYS TO INCREASE THIS SPEED BECAUSE IT COULD BE DANGEROUS.

WARNING: DO NOT ALLOW FAMILIARITY (GAINED FROM FREQUENT USE OF YOUR MACHINE) TO BECOME COMMONPLACE. ALWAYS REMEMBER THAT A CARELESS FRACTION OF A SECOND IS SUFFICIENT TO INFLICT SEVERE INJURY.



The operation of any power tool can result in foreign objects being thrown into the eyes, which can result in severe eye damage. Always wear safety goggles complying with ANSI Z87.1 (shown on Package) before commencing power tool operation. Safety Goggles are available at Sears retail or catalog stores.

motor specifications and electrical requirements

This machine is designed to use a 3450 RPM motor only. Do not use any motor that runs faster than 3450 RPM. It is wired for operation on 110-120 volts, 60 Hz., alternating current. **IT MUST NOT BE CONVERTED TO OPERATE ON 230 VOLTS. EVEN THOUGH SOME OF THE RECOMMENDED MOTORS ARE DUAL VOLTAGE.**

THESE CRAFTSMAN MOTORS HAVE BEEN FOUND TO BE ACCEPTABLE FOR USE ON THIS TOOL.

HP	RPM	VOLTS	CATALOG NO.
1/2	3450	110-120	1216
1/2	3450	110-120	1218
3/4	3450	110-120	1219
3/4	3450	110-120	1226

CAUTION: Do not use blower or washing machine motors or any motor with an automatic reset overload protector as their use may be hazardous.

CONNECTING TO POWER SOURCE OUTLET

This machine must be grounded while in use to protect the operator from electric shock.

Plug power cord into a 110-120V properly grounded type outlet protected by a 15-amp. time delay or Circuit-Saver fuse or circuit breaker.

If you are not sure that your outlet is properly grounded, have it checked by a qualified electrician.

WARNING: DO NOT PERMIT FINGERS TO TOUCH THE TERMINALS OF PLUGS WHEN INSTALLING OR REMOVING THE PLUG TO OR FROM THE OUTLET.

WARNING: IF NOT PROPERLY GROUNDED THIS POWER TOOL CAN INCUR THE POTENTIAL HAZARD OF ELECTRICAL SHOCK. PARTICULARLY WHEN USED IN DAMP LOCATIONS IN PROXIMITY TO PLUMBING. IF AN ELECTRICAL SHOCK OCCURS THERE IS THE POTENTIAL OF A SECONDARY HAZARD SUCH AS YOUR HANDS CONTACTING THE ABRASIVE BELT OR DISC.

If power cord is worn or cut, or damaged in any way, have it replaced immediately.

If your unit is for use on less than 150 volts it has a plug that looks like below.

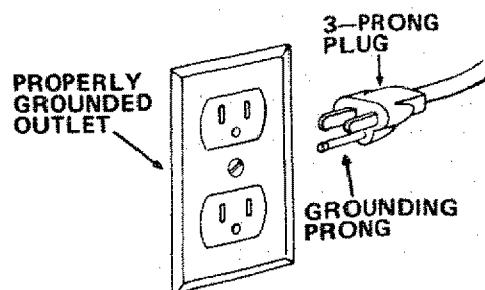

This power tool is equipped with a 3-conductor cord and grounding type plug which has a grounding prong, approved by Underwriters' Laboratories and the Canadian Standards Association. The ground conductor has a green jacket and is attached to the tool housing at one end and to the ground prong in the attachment plug at the other end.

This plug requires a mating 3-conductor grounded type outlet as shown.

If the outlet you are planning to use for this power tool is of the two prong type **DO NOT REMOVE OR ALTER THE GROUNDING PRONG IN ANY MANNER.** Use an adapter as shown and always connect the grounding lug to known ground.

It is recommended that you have a qualified electrician replace the **TWO** prong outlet with a properly grounded **THREE** prong outlet.

An adapter as shown below is available for connecting plugs to 2-prong receptacles. The green grounding lug extending from the adapter must be connected to a permanent ground such as to a properly grounded outlet box.

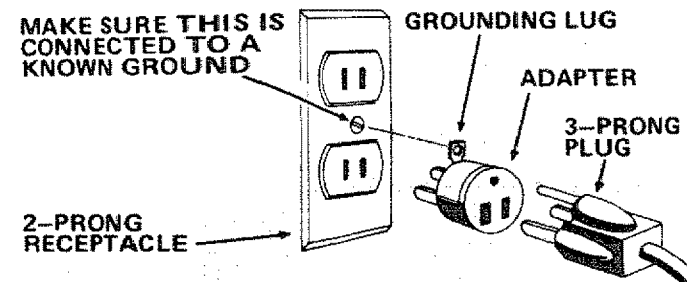

NOTE: The adapter illustrated is for use only if you already have a properly grounded 2-prong receptacle. Adapter is not allowed in Canada by the Canadian Electrical Code.

The use of any extension cord will cause some loss of power. To keep this to a minimum and to prevent overheating and motor burn-out, use the table below to determine the minimum wire size (A.W.G.) extension cord. Use only 3 wire extension cords which have 3-prong grounding type plugs and 3-pole receptacles which accept the tools plug.

Extension Cord Length	Wire Size A.W.G.
Up to 100 Ft.	16
100 - 200 Ft.	14
200 - 400 Ft.	10

CHECK MOTOR ROTATION

WARNING: FOR YOUR OWN SAFETY, MAKE SURE PLUG IS NOT CONNECTED TO POWER SOURCE OUTLET. WHEN CHANGING MOTOR ROTATION.

The motor must rotate **COUNTERCLOCKWISE** when viewed from the shaft end to which you will mount the pulley. (See page 11) If it does not, change the direction according to the instructions furnished with the motor.

CONTENTS

<p>UNPACKING AND CHECKING CONTENTS 6</p> <p>ASSEMBLY 7</p> <p style="padding-left: 20px;">Assembling Steel Legs 7</p> <p style="padding-left: 20px;">Mounting Belt and Disc Sander On Recommended Craftsman Floor Base 8</p> <p style="padding-left: 20px;">Check Motor Rotation 11</p> <p style="padding-left: 20px;">On-Off Switch 12</p> <p style="padding-left: 20px;">Installing Work Table 14</p> <p style="padding-left: 20px;">Installing Abrasive Belt-Tensioning and Tracking 15</p> <p style="padding-left: 20px;">Installing Belt Dust Trap 16</p> <p style="padding-left: 20px;">Installing Backstop 17</p> <p>GETTING TO KNOW YOUR SANDER 17</p> <p style="padding-left: 20px;">Belt Adjusting Screws 18</p> <p style="padding-left: 20px;">Belt Locking Screws 18</p> <p style="padding-left: 20px;">Work Table Tile Lock Screw 18</p> <p style="padding-left: 20px;">Backstop Lock Screw 19</p>	<p style="padding-left: 20px;">Belt Table Locking Bolts 19</p> <p style="padding-left: 20px;">Belt Table Stop 19</p> <p>BASIC OPERATION 20</p> <p style="padding-left: 20px;">Surface Finishing on the Abrasive Belt 20</p> <p style="padding-left: 20px;">End Finishing on the Abrasive Belt 20</p> <p style="padding-left: 20px;">Finishing Curved Edges on the Abrasive Belt 21</p> <p style="padding-left: 20px;">Finishing Small End Surfaces and Curved Edges on the Disc 21</p> <p>MAINTENANCE 22</p> <p style="padding-left: 20px;">Wiring Diagram 22</p> <p>LUBRICATION 22</p> <p>TROUBLE SHOOTING 23</p> <p style="padding-left: 20px;">Recommended Accessories 23</p> <p>REPAIR PARTS 24</p> <p>PARTS LIST 25</p>
--	--

unpacking and checking contents

Model 113.225801 Belt and Disc Sander is shipped complete in one carton but **DOES NOT INCLUDE** Steel Legs or Motor.

Model 113.225831 Belt and Disc Sander is shipped complete in one carton and **INCLUDES** Steel Legs and Motor.

Separate all parts from packing materials and check each item with illustration and "Table of Loose Parts." Make certain all items are accounted for, before discarding any packing material.

If any parts are missing, do not attempt to assemble the Belt and Disc Sander, plug in the power cord, or turn the switch on until the missing parts are obtained and installed correctly.

Using a 1/2" wrench, remove the plywood attached to the machine. Save the nuts and bolts and washers. You will need them for attaching the machine to the base.

TOOLS NEEDED

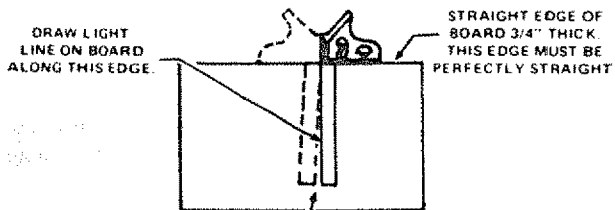
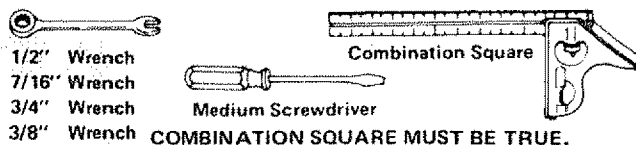

SHOULD BE NO GAP OR OVERLAP HERE WHEN SQUARE IS FLIPPED OVER IN DOTTED POSITION.

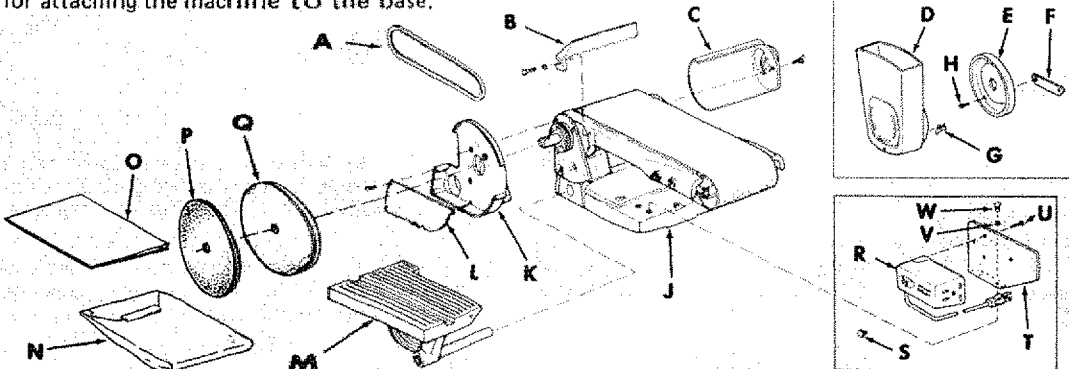

Item	Table of Loose Parts	Qty.
A	V-Belt, 1/2 x 41"	1
B	Backstop	1
C	Belt, Dust Trap	1
D	Motor Pulley Belt Guard	1
E	Belt Guard Support	1
F	Belt Guard Support Bracket	1
G	"S" Clip	3
H	Pan Head Screw, Type 23, 10-32 x 1/2	3
J	Base and Belt, Table (w/Sanding Belt)	1
K	Disc Dust Trap	1
L	Dust Trap Cover	1
M	Work Table	1
N	Bag (containing the following loose parts) (Part No. 68035)	1
	Motor Pulley, 2 In. Dia.	2
	Wrench, 1/2"	1
	5/32 Setscrew Wrench	1
	Flat Head Machine Screw 10-32 x 1-3/4	4

Item	Table of Loose Parts	Qty.
	Pan Head Screw, Type 23 8-32 x 3/8	5
	Flat Washer, 21/64 x 7/8 x 1/8	1
	Hex, Head Machine Screw 5/16-18 x 1	1
	Screw, M Pan Hd. 10-32 x 9/16	1
	Lockwasher No. 10 Int. Tooth	1
	Hanger, Cable	1
O	Owner's Manual	1
P	9" Abrasive Disc	1
Q	Sanding Disc (w/Set Screw)	1
-	Bag Assembly, Outlet (Part No. 68064) (Containing the following loose parts):	
R	Outlet, on/off Power	1
S	Switch Key	1
T	Bracket, Switch Mounting	1
U	Screw, Pan Hd. 8 x 3/8	3
V	Lockwasher, 1/4"	2
W	Screw; Pan Hd. Machine 1/4-20 x 1/2	2

assembly

The following parts are included with Model 113.225831 ONLY.

Item No.		Qty.
* Loose Parts Bag Part #68062 Containing Following Items:		
* A	Nut, Hex Head 1/2-13	8
* A	Nut Hex 1/4-20	32
* B	Screw Truss Hd. 1/4-20 x 5/8	32
* C	Lockwasher, 1/4 External	32
* D	Foot, Leveling	4
E	Motor	1
F	Leg	4
G	Channel, Support	2
H	Stiffener, Side	2
J	Stiffener, End	2
K	Support, Motor	1

HARDWARE FOR MOUNTING TOOL & MOTOR

* L	Screw, Hex Hd. 5/16-18 x 2 1/2	2
* C	Lockwasher Ext. 5/16	6
* A	Nut, Hex 5/16-18	6
* M	Washer 11/32 ID	6
* N	Bolt, Carriage 5/16-18 x 3/4	4

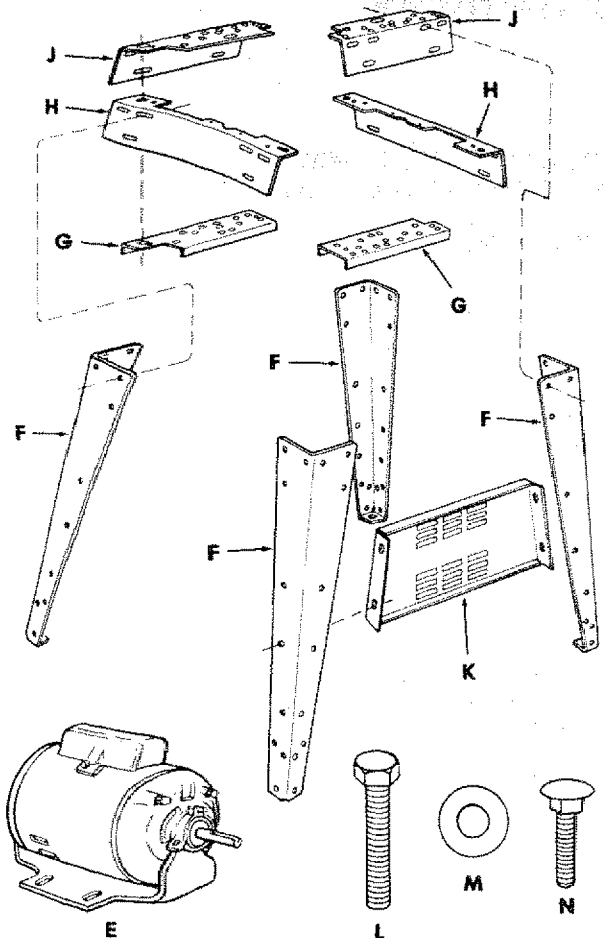
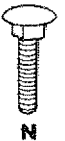
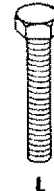
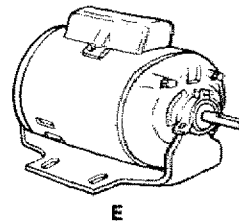
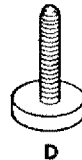

ASSEMBLING STEEL LEGS

(MODEL 113.225831 ONLY)

1. Assemble the two (2) End Stiffeners and the two (2) Side Stiffeners using four (4) 1/4-20 Truss head screws. The End Stiffeners are placed on top of each Side Stiffener as shown. Insert screws through the 9/32 inch diameter holes and finger tighten 1/4-20 nuts.
2. Attach the four (4) legs to the side and End Stiffener using 1/4-20 screws, lockwashers and nuts as shown.
3. Remove the four (4) Truss head screws which were assembled in Paragraph No. One. Place the two (2) Support Channels as shown, in position, align holes in supports with holes in the Stiffeners, replace lockwashers and nuts. Tighten all nuts using 7/16" wrench.
4. Assemble the motor support to steel legs with 1/4-20 screws and nuts. Motor support can be mounted to either end of stand. Tighten nuts.
5. Install leveling feet as shown. To level Leg Set, loosen nut on inside of leg and turn nut on outside to raise or lower feet. Adjust all four levelers, if necessary, and then tighten nuts on inside of leg.

NOTE: These levelers are not intended for height adjustment.

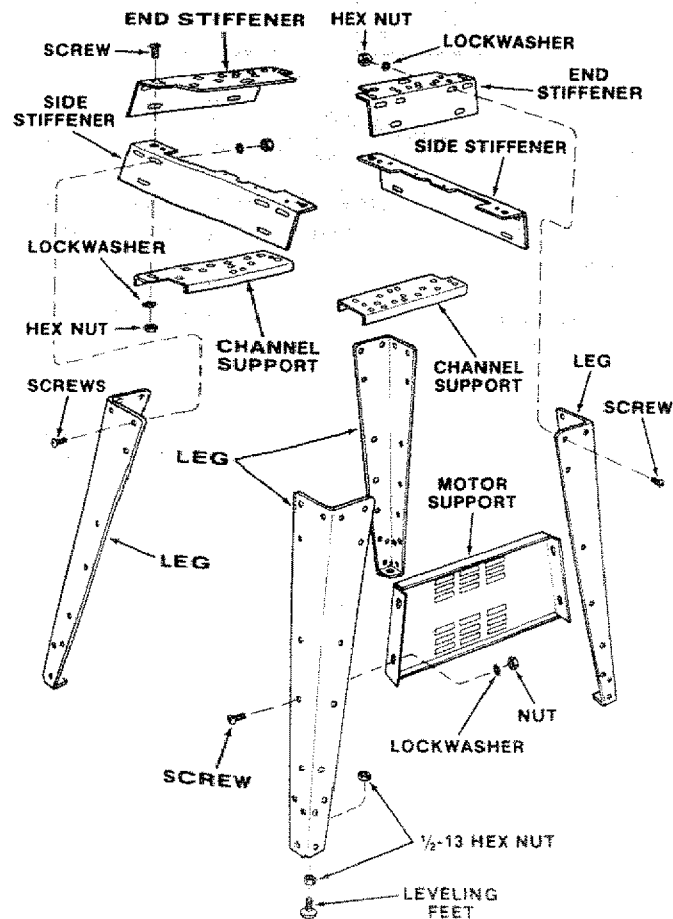

assembly

MOUNTING BELT AND DISC SANDER ON CRAFTSMAN STEEL LEG SET.

CATALOG NO. 9-22236

NOTE: For illustrative purposes, the Belt and Disc Sander is shown mounted on the Craftsman Catalog No. 9-22236 Steel Leg Set. This Leg Set is included with Model No. 113.225831.

1. Place the Belt and Disc Sander on the Steel Legs, position as shown, and align the mounting holes in the feet of the Belt and Disc Sander with those in the **END STIFFENERS** (marked with an X in the illustration).

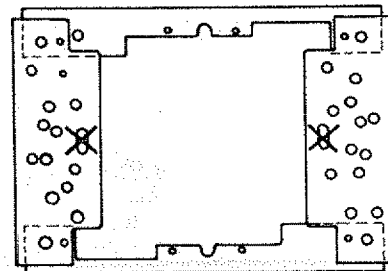
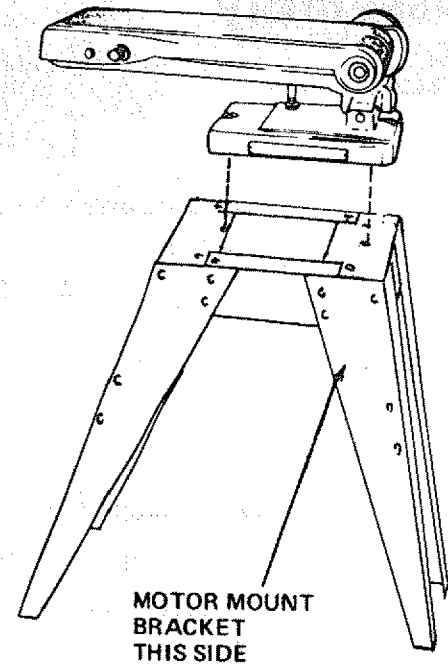

NOTE: The abrasive belt is installed on the machine at the factory so that it does not become damaged during shipment.

1. Loosen both belt **LOCKING** screws, using the 1/2" wrench furnished with the machine.
2. Turn both of the abrasive belt **ADJUSTING** screws as shown until they stop. Retighten the two belt **LOCKING** screws so that the idler pulley does not come out.
3. Slip the abrasive belt off and remove the piece of paper.
4. Remove the protective coating, that is applied at the factory, from the belt table. Use any ordinary household type grease and spot remover.

CAUTION: Never use gasoline, naphtha, or similar highly volatile solvents.

NOTE: Do not apply wax to the belt table.

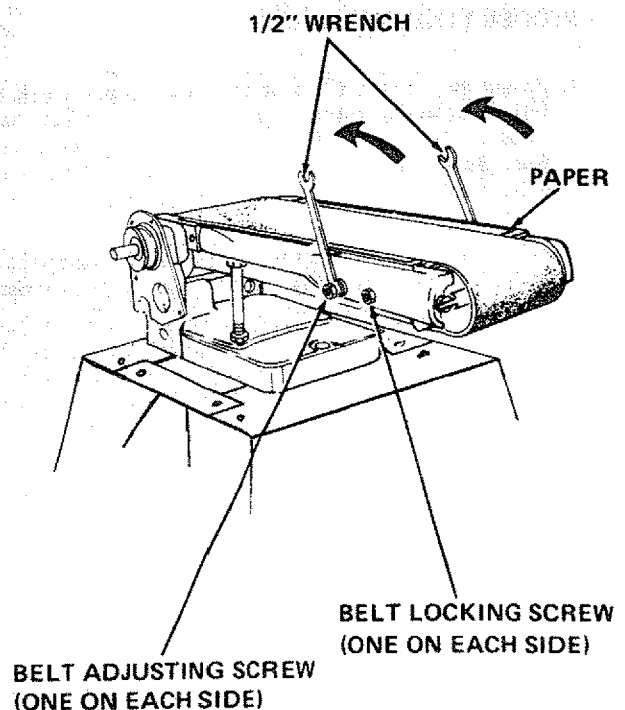

assembly

1. Loosen the belt table locking bolts behind the mounting bracket using one of the 1/2" wrenches supplied with your machine.
2. Position belt table vertically and tighten only one of the bolts.
3. Place the V-Belt over the pulley.
4. Attach the switch assembly to the base using the two screws and washers packed with the switch.
5. Loosen the bolt that you tightened in step 2. Position the belt table horizontally, and tighten both bolts.

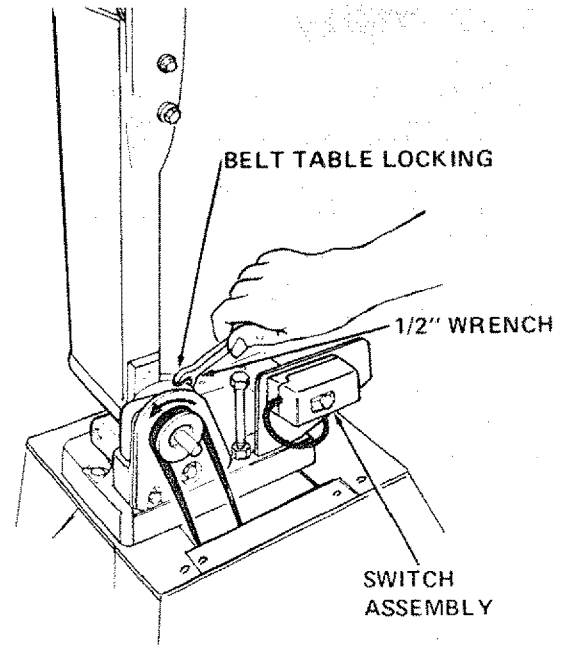

6. Find five 3/8" Pan Head Self-Treading screws from among the loose parts.

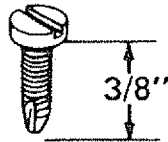

7. Place Disc Dust Trap on your workbench and screw in five Pan Head "Thread Cutting Screws," 3/8" long. Screw them in all the way.

NOTE: The holes in the Trap are not threaded but the screws are "Thread Cutting Screws" and will cut a thread as they are tightened.

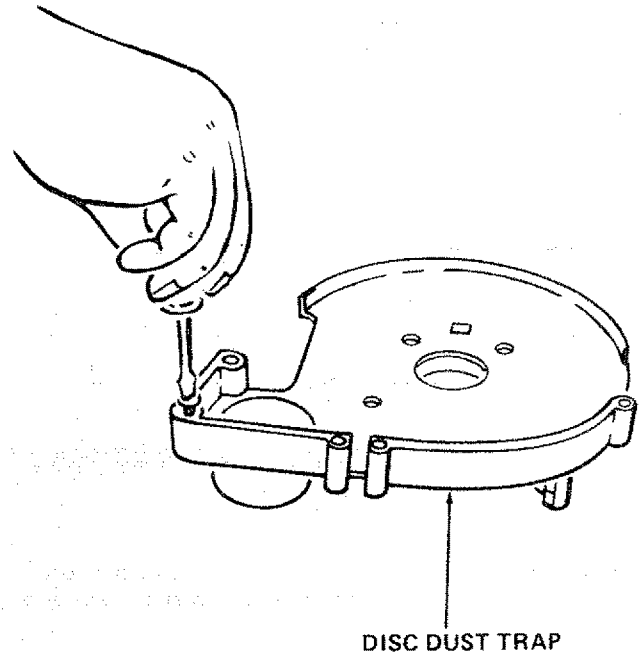

8. Find four Flat Head Machine Screws 1-3/4" long from among the loose parts

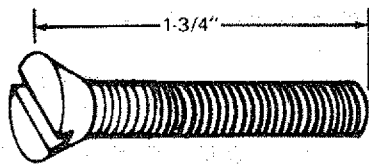

9. Attach the Disc Dust Trap with four flat head screws 1-3/4" long.
10. There is a flat spot on the shaft near the end. Rotate the shaft so that the flat spot is facing up.

FLAT HEAD SCREWS
1 3/4" LONG

FLAT SPOT
ON SHAFT

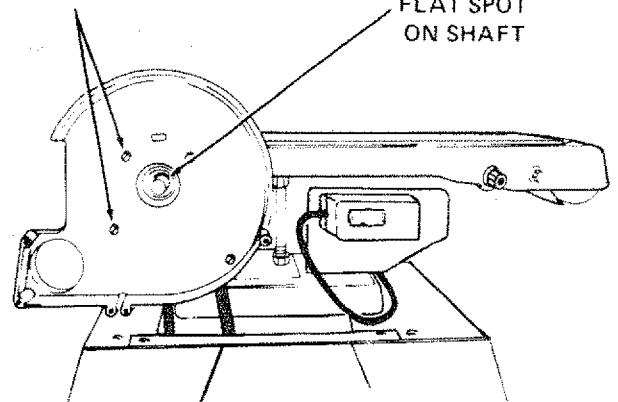

assembly

11. Place the disc on the shaft so that the set screw is facing up. Position the disc so that it is approx. 1/16 inch outward from the edge of the dust trap.
12. Insert the long end of the 5/32" setscrew wrench through the hole in the disc housing and into the setscrew in the disc. Make sure setscrew is aligned with "Flat" on shaft.

NOTE: After several hours of operation, check for looseness of setscrew and retighten.

13. Make certain that the metal disc is free of oil and grease then peel the backing from the 9" abrasive disc and affix to the sanding disc.

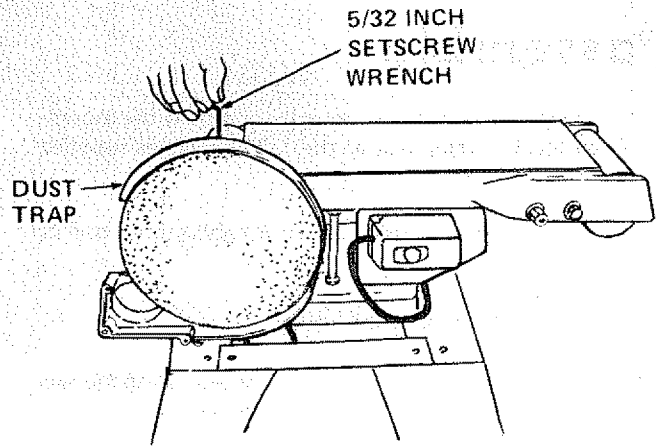

14. Remove the two lower screws which you installed in step 6 and loosen the other three screws.
15. Install the Dust Trap cover and replace the two screws. Tighten all five screws.

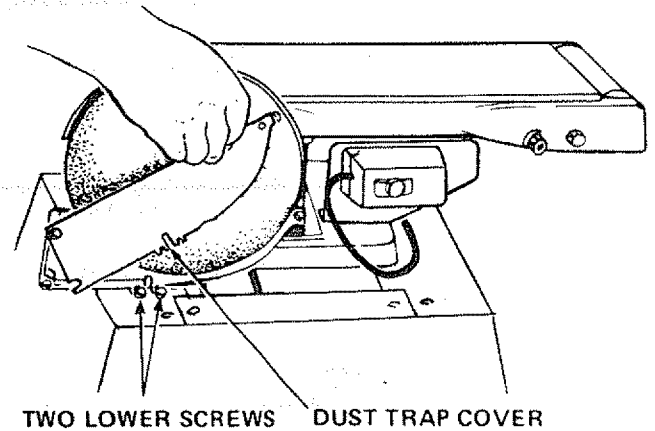

MOTOR BASE CLAMP SCREWS

1. Place the motor on your workbench with the 5/8 Dia. shaft (with key way) facing you.
2. Loosen the two motor base clamp screws and rotate the motor so that the ventilation holes are facing to the side . . . tighten the screws.

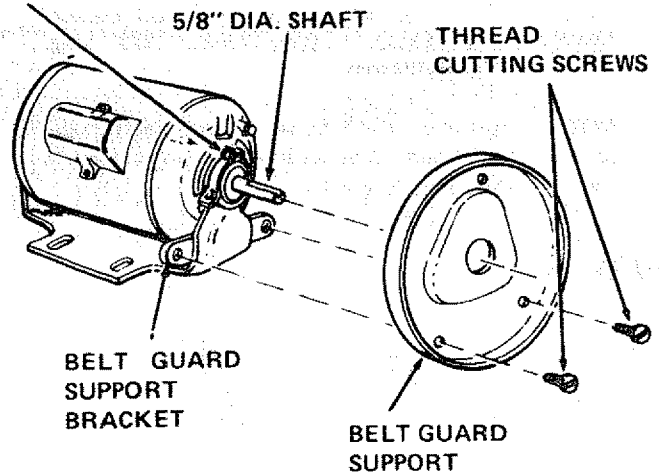

3. Attach guard support to the bracket with the two screws furnished with the belt guard.

NOTE: The holes in the bracket are not threaded, but the screws are "thread cutting screws" and will cut a thread as they are tightened.

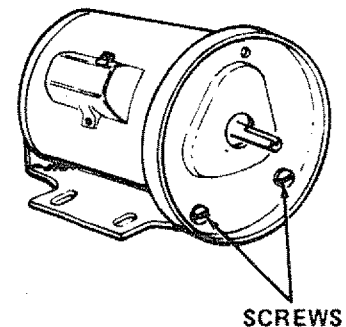

assembly

- Loosen setscrew in motor pulley and place the pulley on the shaft with the hub flush with the end of the shaft, insert the motor shaft key and tighten setscrew with 5/32" setscrew wrench.

CHECK MOTOR ROTATION

The motor must rotate **COUNTERCLOCKWISE** when viewed from the **PULLEY** end.

- Place the motor on your workbench or on the floor.
- Stand clear of the motor and plug the cord into a properly grounded outlet (See page 5). Notice the rotation of the pulley. If it is not turning **COUNTERCLOCKWISE**, **REMOVE** the plug from the outlet, and change the rotation of the motor according to the instructions furnished with the motor.

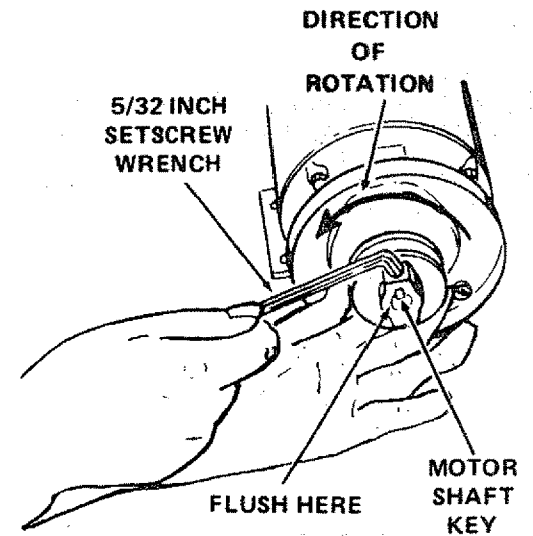

WARNING: FOR YOUR OWN SAFETY, MAKE SURE PLUG IS NOT CONNECTED TO POWER SOURCE OUTLET.

- Find four 5/16" - 18 x 1" carriage bolts, flat washers, lock washers and nuts supplied with base.

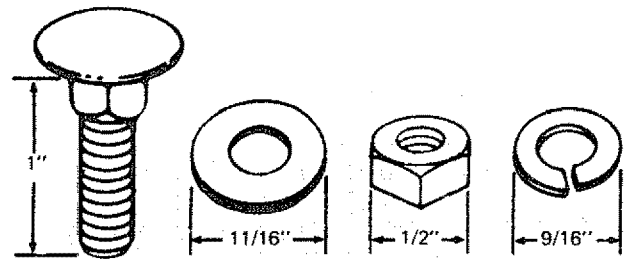

- Attach motor by inserting carriage bolts through slots in motor base and then through slots marked "X" in motor mount bracket, then place flat washers and lockwashers on each bolt ... screw on nuts but **DON'T TIGHTEN** them.

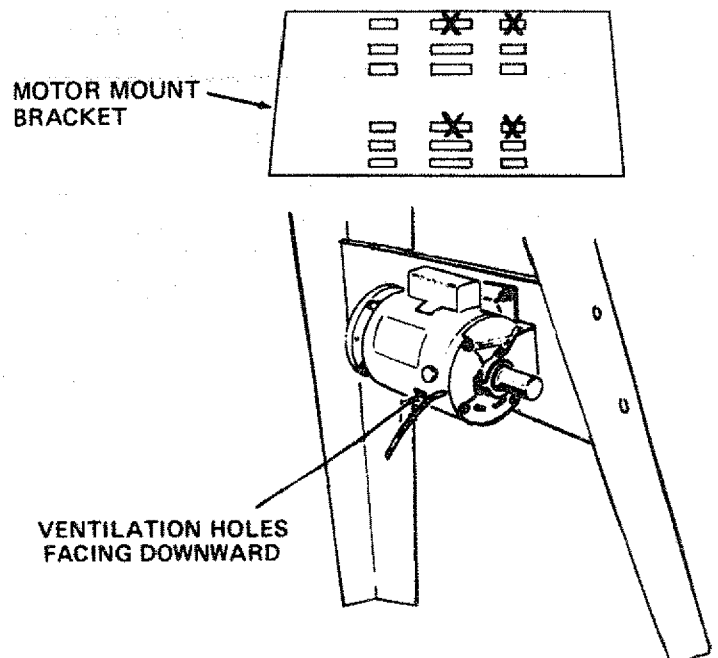

assembly

3. Install three clips on the belt guard 90° apart with the long tabs pointing AWAY from the round opening.
4. Insert the belt into the open end of the guard and out the round opening.

MAKE SURE BELT HAS NOT SLIPPED OFF OF MACHINE PULLEY.

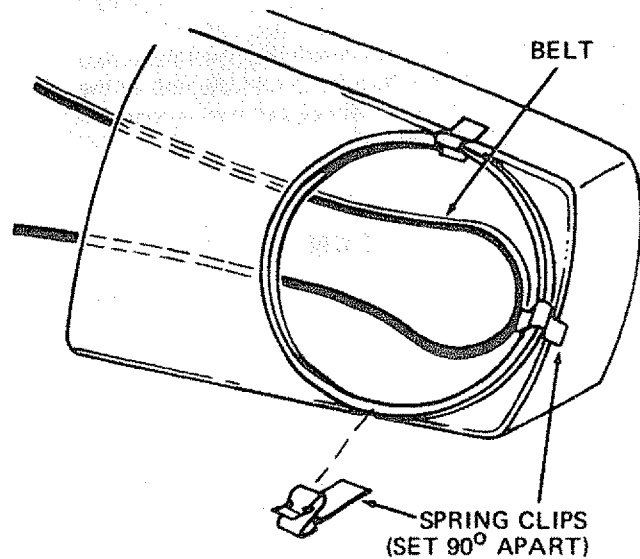

6. Place the belt onto the motor pulley by rotating the pulley.
7. Snap the belt guard into position.
8. Move the motor sideways so that the belt is in the center of the opening in the top of the base.
9. PUSH downward on motor to apply tension to belt and tighten motor bolt nuts.

NOTE: It is only necessary to tension the belt so that it does not slip while running.

10. If you cannot obtain sufficient tension with the motor pushed all the way down, remove the four motor bolts and insert them in the next LOWER set of holes.

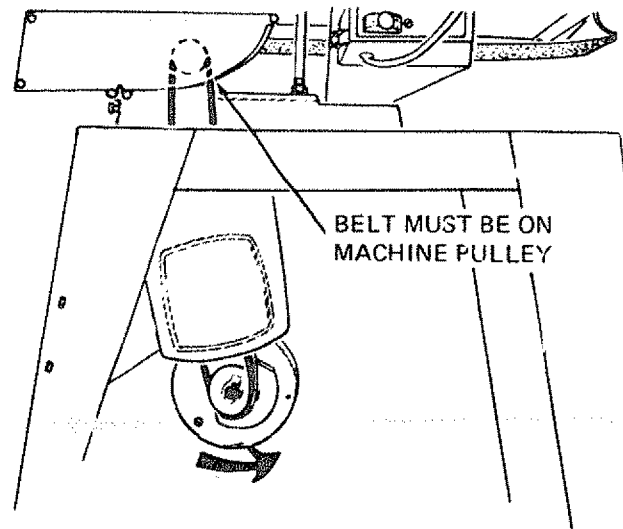

ON-OFF SWITCH

WARNING: DON'T CONNECT POWER CORD TO ELECTRICAL OUTLET IN YOUR SHOP UNTIL YOU ARE READY TO CHECK MOTOR ROTATION.

The On-Off Switch has a locking feature. THIS FEATURE IS INTENDED TO PREVENT UNAUTHORIZED AND POSSIBLE HAZARDOUS USE BY CHILDREN AND OTHERS.

1. Insert key into switch.

NOTE: Key is made of yellow plastic

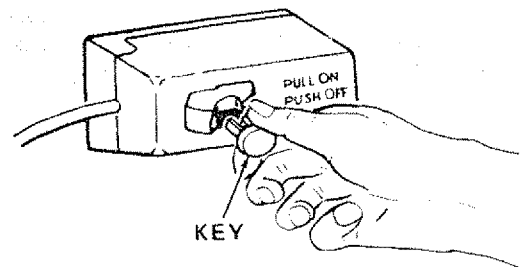

assembly

2. To turn machine on, insert finger under switch lever and pull end of switch out.

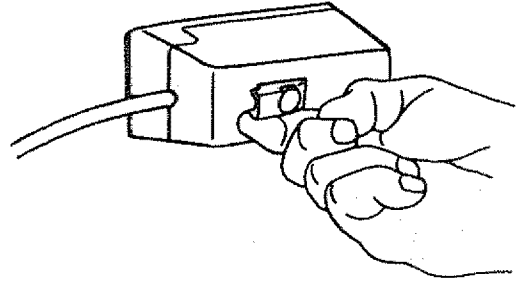

3. To turn machine OFF . . . PUSH lever in.

Never leave the machine unattended until it has come to a complete stop.

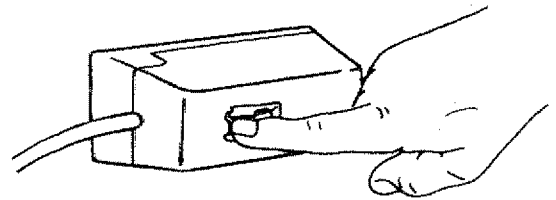

4. To lock switch in OFF position . . . hold switch IN with one hand . . . REMOVE key with other hand.

WARNING: FOR YOUR OWN SAFETY, ALWAYS LOCK THE SWITCH "OFF" WHEN MACHINE IS NOT IN USE . . . REMOVE KEY AND KEEP IT IN A SAFE PLACE . . . ALSO . . . IN THE EVENT OF A POWER FAILURE (ALL OF YOUR LIGHTS GO OUT) TURN SWITCH OFF . . . LOCK IT AND REMOVE THE KEY. THIS WILL PREVENT THE MACHINE FROM STARTING UP AGAIN WHEN THE POWER COMES BACK ON.

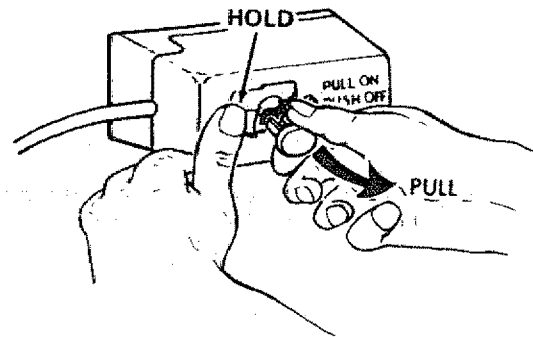

5. Find plastic cable hanger from among the loose parts.



assembly

WILSON JORDAN

6. Route the motor cord behind the motor mount, across the top of the base and plug it into the receptacle in the side of the switch box.
7. Bring the power cord alongside the motor cord . . . wrap the plastic cable hanger around the cords and attach the hanger to the top of the base by pushing it into a $\frac{1}{4}$ " diameter hole.

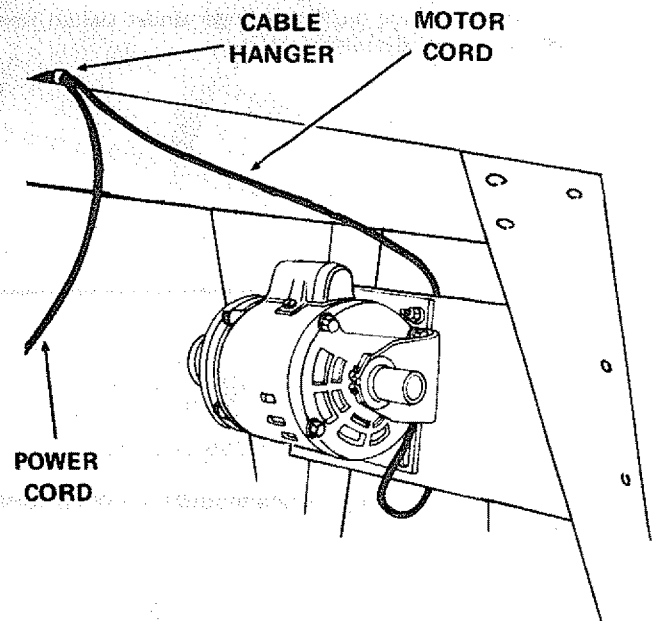

INSTALLING WORK TABLE

NOTE: Apply coat of paste wax to the work table. This will make it a little easier to feed the work.

1. Loosen the table positioning screw.
2. Insert the table support rod in the hole in the base until the edge of the table is approximately $\frac{1}{16}$ " from the abrasive disc. Tighten the screw.

NOTE: There is a second mounting hole in the base. This is for mounting the table when the belt is used in a vertical position.

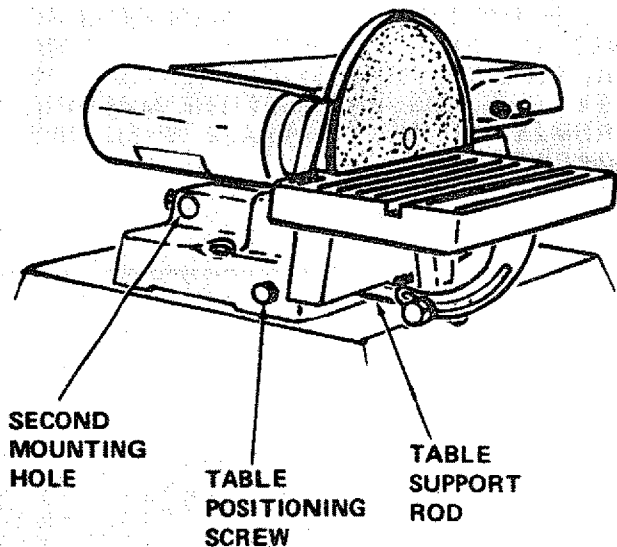

assembly

INSTALLING ABRASIVE BELT—TENSIONING AND TRACKING

WARNING: FOR YOUR OWN SAFETY, TURN SWITCH "OFF" AND REMOVE PLUG FROM POWER SOURCE OUTLET BEFORE REMOVING OR INSTALLING ABRASIVE BELT.

On the smooth side of the abrasive belt you will find a "directional arrow." The abrasive belt must run in the direction of this arrow so that the splice does not come apart.

1. Loosen the two abrasive belt LOCKING screws.
2. Place the abrasive belt over the pulleys with the directional arrow pointing as shown. Make sure the abrasive belt is centered on both pulleys.

Turning the abrasive belt ADJUSTING screws will cause the idler pulley to move in or out. When the idler pulley is moved outward, it puts TENSION on the belt.

3. Place both of the ½" wrenches on the ADJUSTING screws and pull the wrenches toward you. This will stretch the abrasive belt. Move the wrenches back and forth a few times so that you "get the feel" of the abrasive belt while it is stretching (TENSIONING).

Apply a small amount of TENSION to the abrasive belt by pulling the wrenches toward you, so that the TENSION feels the same on both wrenches.

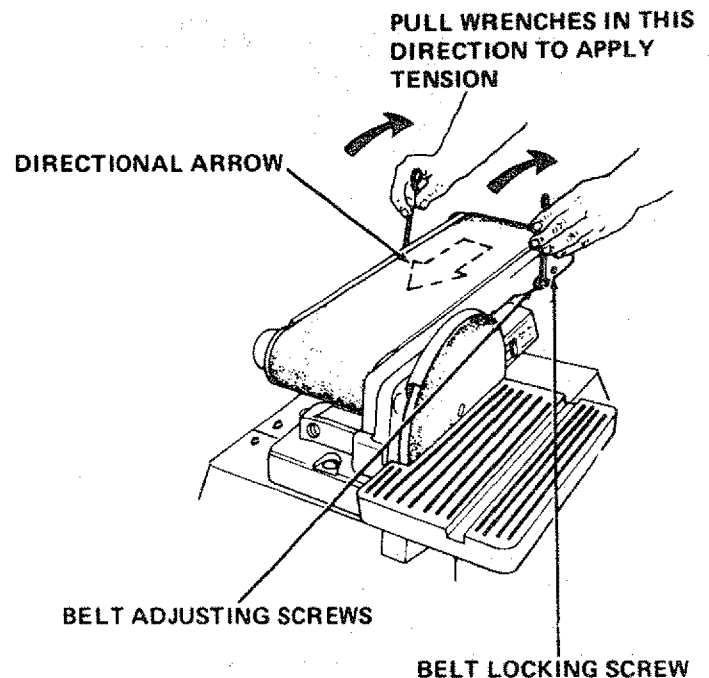

4. Hold the abrasive disc with your left hand to keep it from turning while pushing the belt in the direction of the arrow if the abrasive belt slips over the pulleys, turn both ADJUSTING screws simultaneously a small amount to apply a little more tension to the abrasive belt.
5. Adjust the tension so that the abrasive belt does not slip very easily when pushing it, while you are holding the disc.
6. Tighten the locking screws.
7. Plug in the power cord. Turn the switch "on", let the machine run for about three to five seconds and then turn it "off". Notice if the belt while running, moved to the right or to the left. If it did not move to the right or left, it is TRACKING properly.

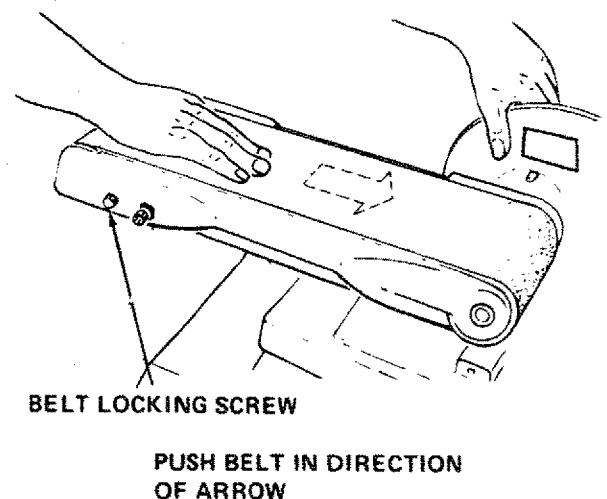

assembly

8. IF THE ABRASIVE BELT RUNS OFF TO THE RIGHT:

- Loosen the LOCKING SCREW on the RIGHT.
- Place wrench on the ADJUSTING SCREW on the right.
- Turn switch on and pull the wrench toward you. This will move the abrasive belt to the left. PUSHING the wrench will move the belt to the right.
- The abrasive belt is tracking properly when it is centered on the DRIVE pulley.

IMPORTANT: If you have difficulty tracking the belt, apply more tension.

9. IF THE ABRASIVE BELT RUNS OFF TO THE LEFT:

- Loosen the LOCKING SCREW on the LEFT.
- Place wrench on the ADJUSTING SCREW on the left.
- Turn switch on and pull the wrench toward you. This will move the abrasive belt to the right. PUSHING the wrench will move the abrasive belt to the left.
- The abrasive belt is tracking properly when it is centered on the DRIVE pulley.

IMPORTANT: If you have difficulty tracking the abrasive belt, apply more tension.

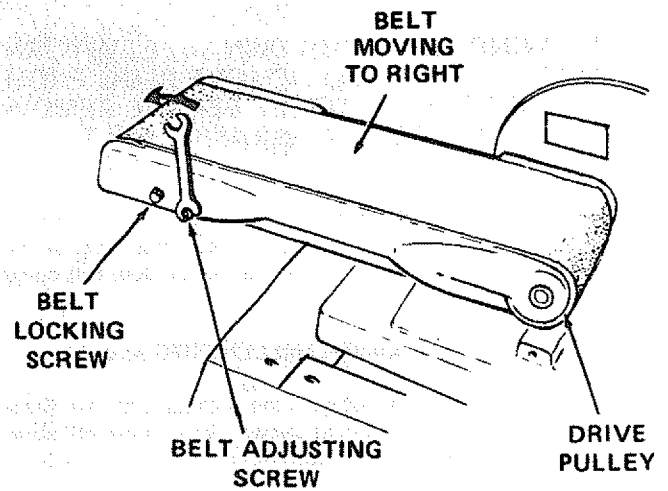

INSTALLING BELT DUST TRAP

- Find one 10 - 32 x 9/16" Pan Head screw and a lockwasher among the loose parts.

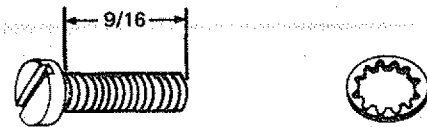

- Attach the dust trap . . . make sure the top edge is below the surface of the abrasive belt.

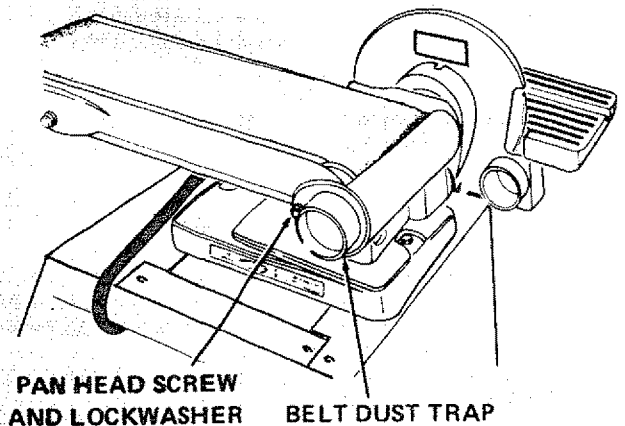

assembly

INSTALLING BACKSTOP

1. Find one 5/16" x 1" Hex. Head bolt and one flat washer among the loose parts.
2. Place the washer on the bolt, and screw it halfway into the mounting hole. Place the backstop into position and tighten the bolt. When removing the backstop, loosen the bolt but do not remove it.

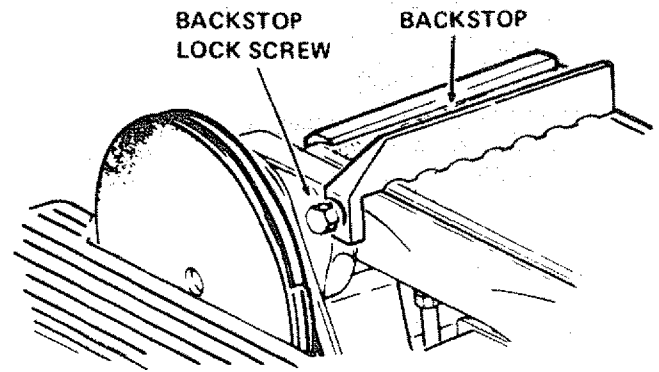

getting to know your belt and disc sander

WARNING: FOR YOUR OWN SAFETY TURN SWITCH "OFF" AND REMOVE PLUG FROM POWER SOURCE OUTLET BEFORE MAKING ANY ADJUSTMENTS.

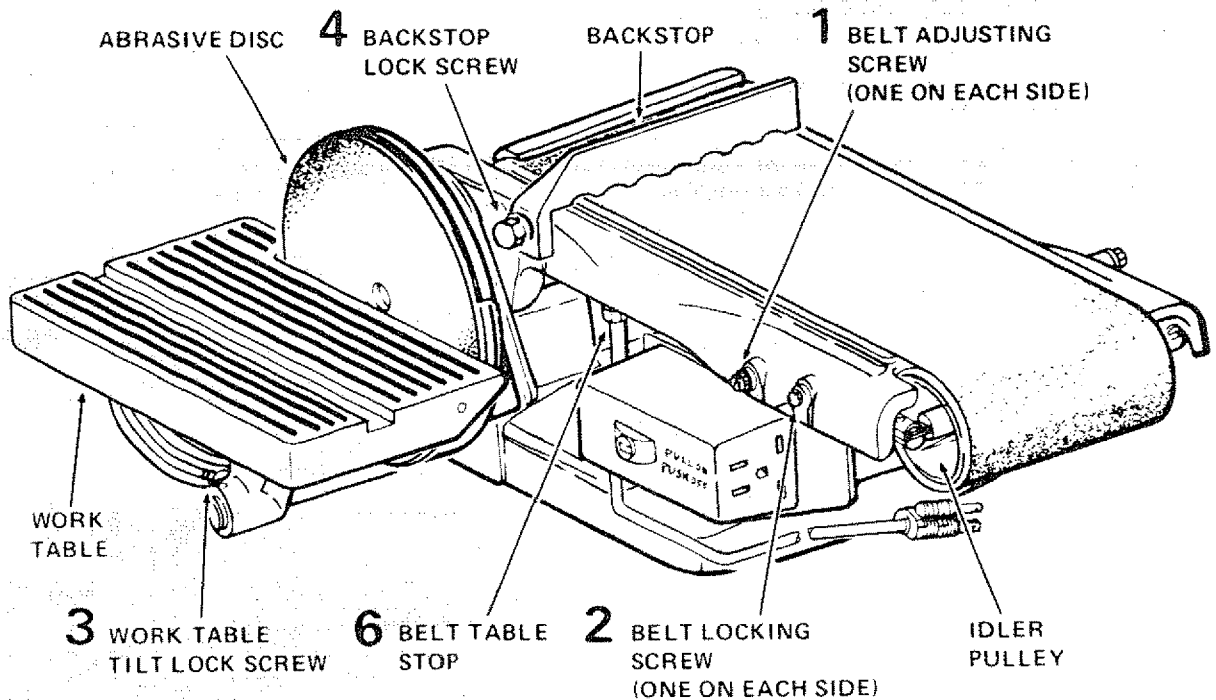

assembly

- 1. ABRASIVE BELT ADJUSTING SCREWS** cause the idler pulley to move in or out for applying tension to the abrasive belt or for tracking it. They are adjusted using the 1/2" wrenches.

See "Assembly" section . . . "Installing Abrasive Belt".

- 2. ABRASIVE BELT LOCKING SCREWS** lock the adjustment mechanism after the abrasive belt is tensioned and tracking properly. They are locked using the 1/2" wrench.

See "assembly" section . . . "Installing Abrasive Belt".

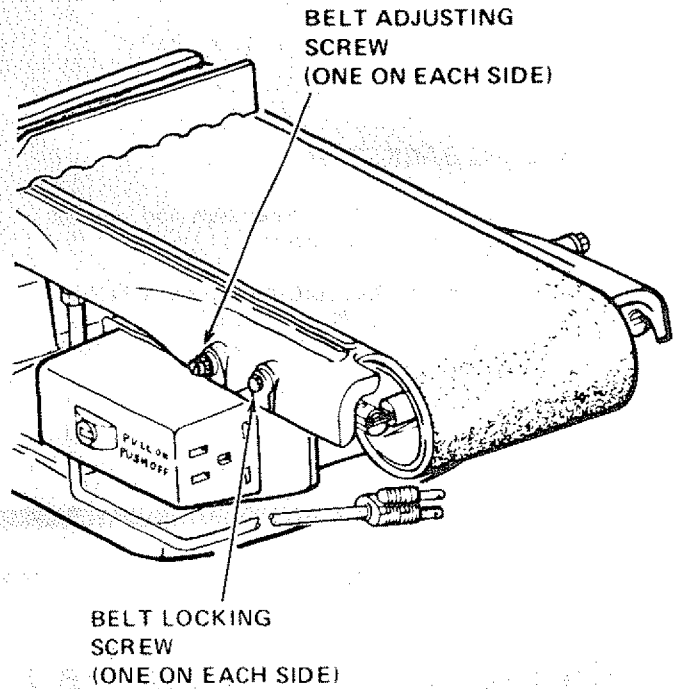

- 3. WORK TABLE TILT LOCK SCREW** locks the table. It is locked using the 1/2" wrench.

- Using a combination square, check the angle of the table with the disc.

NOTE: The combination square must be "true"—See start of assembly section on Pg. 6 for checking method.

- If the table is not 90° with the disc . . . loosen tilt lock screw and tilt table.
- Loosen the lock nut using a 7/16" wrench.
- Screw the stop screw in or out, using a 3/8" wrench so that when the table touches the stop screw, the table is 90° to the disc.
- Tighten the lock nut.

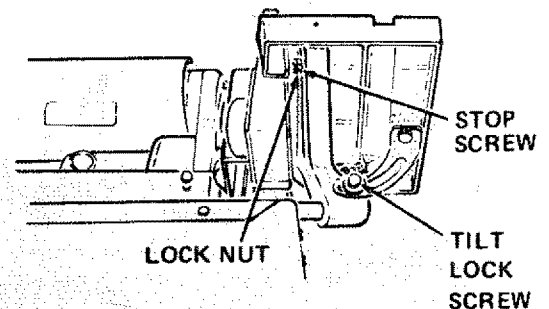
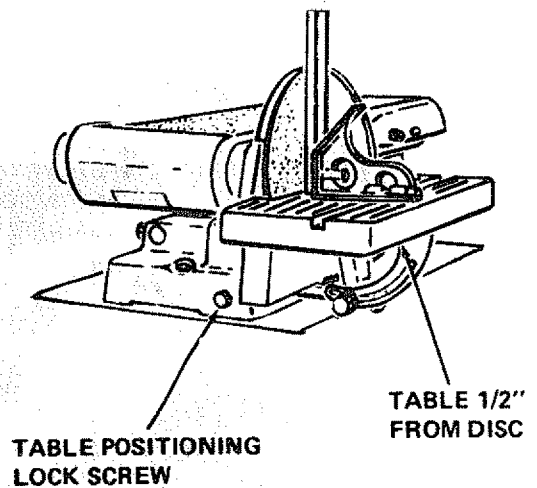

getting to know your belt and disc sander

- f. Loosen the table positioning lock screw . . . position the table approximately 1/16" away from the abrasive disc.
- g. Tilt the table downward but don't tighten the lock screw, and position it as close to the disc as possible. Using the head of a combination square, check the angle of the table with the disc.
- h. If the table is not 45° with the disc:
- i. Raise the table and loosen the lock nut using a 7/16" wrench.
- j. Screw the stop screw in or out, using a 3/8" wrench so that when the table touches it, it is 45° with the disc.
- k. Tighten the lock nut.

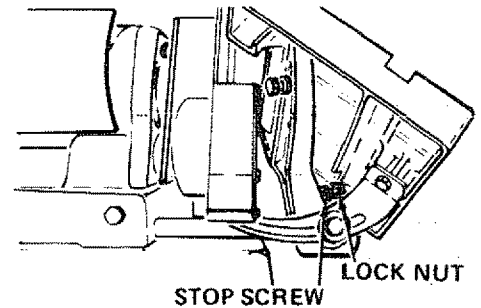
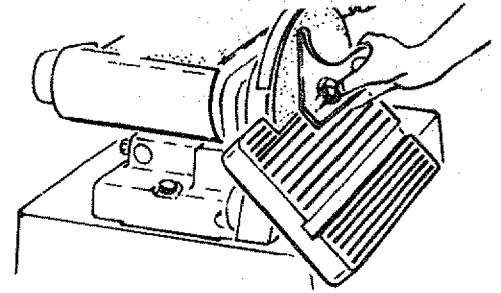

-
4. **BACKSTOP LOCK SCREW** locks the backstop in place. It is locked using the 1/2" wrench.

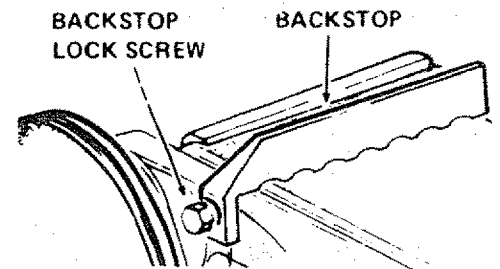

-
5. **BELT TABLE LOCKING BOLTS** . . . lock the belt table in position.

To adjust to vertical position:

- a. Remove the backstop.
 - b. Loosen the two belt table locking bolts using the 1/2" wrench supplied with your machine.
 - c. Position belt table vertically and tighten the two bolts.
6. **ABRASIVE BELT TABLE STOP** can be adjusted so that the abrasive belt table is level with the floor when in a horizontal position.

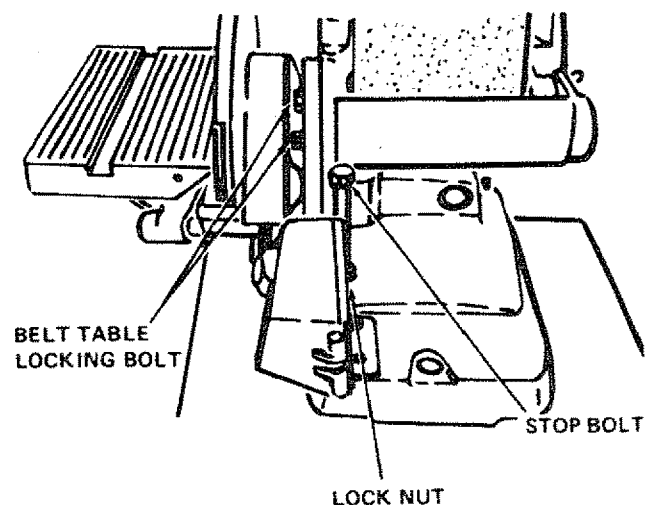

- a. Loosen the lock nut using a 3/4" wrench.
- b. Place a level on the abrasive belt table and using a 3/4" wrench, screw the stop bolt in or out until the table is level.

basic operation

SURFACE FINISHING ON THE ABRASIVE BELT.

FLAT SURFACES

Hold the work piece firmly with both hands, keeping fingers away from the abrasive belt.

Keep the end butted against the backstop and move the work evenly across the abrasive belt. Use extra caution when finishing very thin pieces.

For finishing long pieces, remove the backstop.

Apply only enough pressure to allow the abrasive belt to remove material. If the abrasive belt stalls and the belt pulleys slip while applying moderate pressure to the workpiece, the abrasive belt requires more tension.

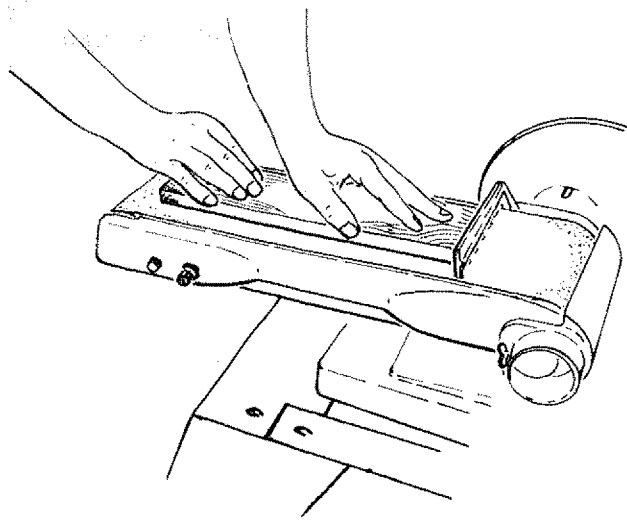

END FINISHING ON THE ABRASIVE BELT.

It is more convenient to finish the ends of long workpieces with the abrasive belt in a vertical position.

Move the work evenly across the abrasive belt. For accuracy, use a miter gauge.

The table may be tilted for beveled work.

See Getting To Know Your Finishing Machine section for adjusting the abrasive belt table and the work table.

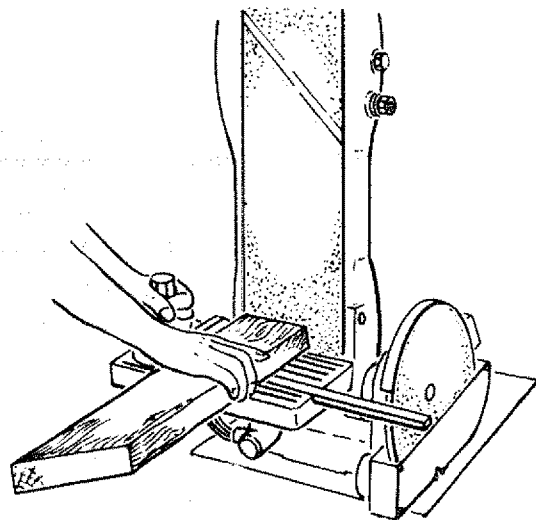

basic operation

FINISHING CURVED EDGES ON THE ABRASIVE BELT CURVED EDGES

Finish outside curves on the abrasive belt and inside curves on the idler pulley.

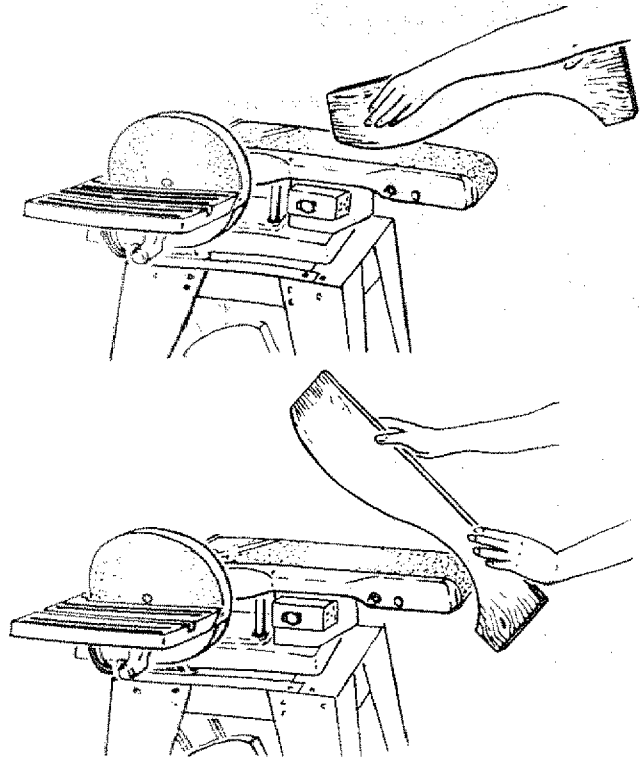

FINISHING SMALL END SURFACES AND CURVED EDGES ON THE ABRASIVE DISC

Move the work across the "Down Side" of the face of the abrasive disc. For accuracy, use a miter gauge.

NOTE: Use a combination square to square the miter gauge to the face of the disc. If it is not square, pull out the index pin, loosen the miter gauge knob and move the miter gauge slightly until it is square. Without moving the miter gauge, tighten the knob securely.

Applying the workpiece to the "Up Side" could cause it to fly up (kickback) which could be hazardous.

The table may be tilted for beveled work.

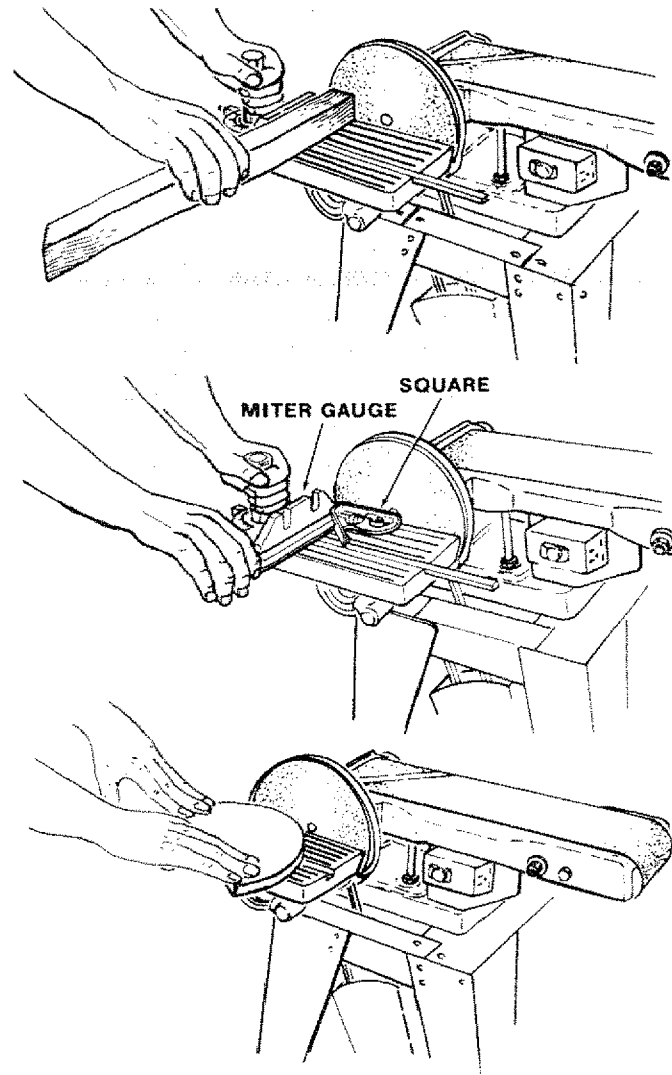

maintenance

WARNING: FOR YOUR OWN SAFETY, TURN SWITCH "OFF" AND REMOVE PLUG FROM POWER SOURCE OUTLET BEFORE ADJUSTING, MAINTAINING, OR LUBRICATING YOUR FINISHING MACHINE.

Keep your machine and your workshop clean. The dust traps around the abrasive disc and the abrasive belt are designed to deflect most of the fine dust. They should be connected to a Home-N-Shop Vac for most efficient dust removal.

WARNING: DO NOT ATTACH A HOME-N-SHOP VAC WHEN FINISHING IRON OR STEEL. THE SPARKS COULD IGNITE THE DEBRIS AND CAUSE A FIRE.

If power cord is worn or cut, or damaged in any way, have it replaced immediately.

Frequently blow out any dust that may accumulate inside the motor.

For motor maintenance, follow instructions furnished with motor.

A coat of automobile-type wax applied to the worktable will make it a little easier to feed the work while finishing.

Do not apply wax to the abrasive belt table because the belt could pick up the wax and deposit it on the pulleys, causing the belt to slip.

lubrication

The **BALL BEARINGS** in this machine are packed with grease at the factory. They require no further lubrication.

Periodically lubricate the cams and shafts in the idler pulley mechanism with Silicon Spray.

For motor lubrication, follow instructions furnished with motor.

trouble shooting

WARNING: FOR YOUR OWN SAFETY, TURN SWITCH "OFF" AND REMOVE PLUG FROM POWER SOURCE OUTLET BEFORE TROUBLE SHOOTING YOUR SANDER.

TROUBLE SHOOTING CHART

TROUBLE	PROBABLE CAUSE	REMEDY
Motor will not run.	<ol style="list-style-type: none"> 1. Defective On-Off switch. Defective switch cord. Defective switch box receptacle. 2. Motor protector open, (only if your motor is equipped with an overload protector). Other cause. 	<ol style="list-style-type: none"> 1. Replace defective parts before using belt disc sander again. 2. Consult Sears Service. Any attempt to repair this motor may create a HAZARD unless repair is done by a qualified service technician. Repair service is available at your nearest Sears Store.
Machine slows down when finishing.	<ol style="list-style-type: none"> 1. V-Belt too loose. 2. Applying too much pressure to workpiece. 3. Too much tension on abrasive belt. 	<ol style="list-style-type: none"> 1. Increase belt tension, see Assembly Section, "Motor Pulley Belt Guard and Motor Installation." 2. Ease up on pressure. 3. Adjust tension, see Assembly Section, "Installing and Adjusting Abrasive Belt."
Abrasive Belt Slips	<ol style="list-style-type: none"> 1. Not enough tension. 	<ol style="list-style-type: none"> 1. Adjust tension, see Assembly Section, "Installing and Adjusting Abrasive Belt."
Abrasive Belt runs off pulleys.	<ol style="list-style-type: none"> 1. Not tracking properly. 2. Not enough tension. 	<ol style="list-style-type: none"> 1. Adjust tracking, see Assembly Section, "Installing and Adjusting Abrasive Belt." 2. Adjust tension, see Assembly Section, "Installing and Adjusting Abrasive Belt."
Wood burns while finishing.	<ol style="list-style-type: none"> 1. Abrasive disc or belt is glazed with sap. 	<ol style="list-style-type: none"> 1. Replace disc or belt.

RECOMMENDED ACCESSORIES

ITEM	CAT. NO.
Steel Stand	9-22213
Miter Gauge	9-29929
Pressure-Sensitive cement	9-2220
Abrasive Belts and Disc	SEE CATALOG
Steel Legs	9-22236
Stop Rods	9-29924
Power Tool Know How Handbooks	
Radial Saw	9-2917
Table Saw	9-2918

The above recommended accessories are current and were available at the time this manual was printed.

CRAFTSMAN BELT AND DISC SANDER MODEL NO. 113.225801 & 113.225831

repair parts

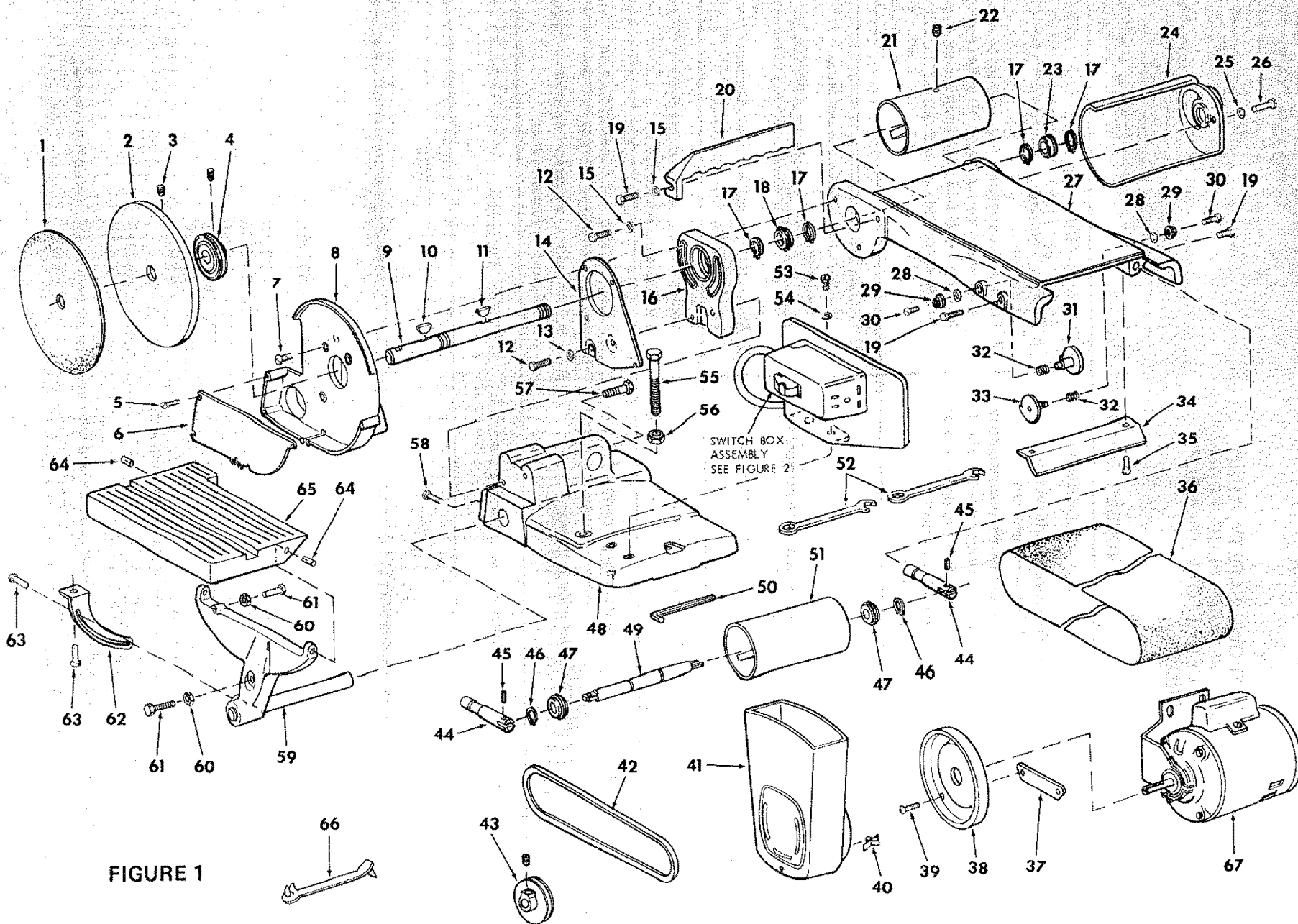

PARTS LIST

CRAFTSMAN BELT AND DISC SANDER MODEL NO. 113.225801 & 113.225831

FIGURE 1 PARTS LIST

Key No.	Part No.	Description	Key No.	Part No.	Description
1	38834	†Disc, 9 Inch Abrasive	36	47813	†Belt, Sanding
2	68033	Disc, Sanding (w/Set Screw)	37	60254	Bracket, Support
3	STD503103	*Screw, Socket Head Set, 5/16-18 x 5/16	38	60253	Support, Belt Guard
4	30646	†Pulley (w/Set Screw) 2-1/2 dia. x 1/2, "V" Groove 5/8 bore, Keyed	39	STD601105	*Screw, Type 23 Pan Head No. 10-32 x 1/2
5	STD600803	*Screw, Type 23, Pan No. 8-32 x 3/8	40	60255	"S" Clip
6	68003	Cover, Housing	41	60252	Guard, Belt
7	133656	*Screw, Machine Flat Head No. 10-32 x 1-3/4	42	STD304410	†V-Belt, 1/2 x 41"
8	68004	Housing, Disc	43	62023	†Pulley, (w/Set Screw) 2" Dia. x 1/2 "V" Groove 5/8 Bore
9	68013	Shaft, Drive	44	47622	Shaft, Control
10	STD580025	Key, Woodruff, No. 9	45	STD571807	Pin, Roll 3/16 x 5/8
11	38812	Key, Woodruff	46	38538	Ring, Retaining 5/8
12	STD523115	*Screw, Hex Head 5/16-18 x 1-1/2	47	38536	Bearing, Ball
13	STD551131	*Lockwasher, 5/16	48	68015	Base
14	68005	Bracket, Mounting	49	47621	Shaft, Idler
15	STD551031	*Washer, 21/64 x 7/8 x 1/8	50	60096	*Wrench Hex., 5/32
16	47218	Bracket, Table Support	51	47414	Pulley, Idler
17	37158	Ring, Retaining 5/8	52	68017	Wrench
18	STD315228	Bearing, Ball	53	STD512505	*Screw, Machine Pan Head 1/4-20 x 1/2
19	STD523112	*Screw, Machine Hex Head 5/16-18 x 1-1/8	54	STD551125	*Lockwasher, 1/4
20	47222	Backstop	55	100167	*Bolt, Hex. Head, 1/2-13 x 4-1/2
21	47190	Pulley, Drive (w/Set Screw)	56	STD541250	*Nut, Hex., 1/2-13
22	STD502502	*Screw, Socket Head Set, 1/4-20 x 5/16	57	STD523107	Bolt, High Strength, 5/16-18 x 3/4
23	STD315228	††Bearing Ball	58	STD523122	Bolt, High Strength, 5/16-18 x 2-1/4
24	68006	Trap, Dust	59	68016	Support Assembly, Base
25	STD551210	*Lockwasher No. 10 Int. Tooth	60	STD541025	*Nut, Hex., 1/4-20
26	STD511105	*Screw Mach. Pan Hd. 10-32 x 9/16	61	STD522512	*Screw, Machine Hex. Head, 1/4-20 x 1-1/4
27	68014	Table, Belt	62	38738	Bracket, Table Lock
28	STD551037	*Washer, 3/8 x 3/4 x 1/16	63	9416187	*Screw, Ty "T" 5/16-18 x 3/4 Hex. Head
29	68007	Nut, Cam	64	STD571812	*Pin, Roll 3/16 x 1-1/4
30	STD510605	*Screw, Machine Pan Slotted No. 6-32 x 7/16	65	68055	Table, Work
31	68008	Cam, Left Hand	66	68036	Hanger, Cable
32	47815	Spring	67	68063	†Motor (Model 113.225831)
33	68009	Cam, Right Hand		68065	Owner's Manual (Not Illustrated)
34	68010	Guard, Idler		68035	Bag of Loose Parts (Not Illustrated)
35	STD510803	*Screw, Machine Pan Head No. 8-32 x 3/8		68064	Bag of Loose Parts (Not Illustrated)

* Standard Hardware Item - May Be Purchased Locally.

† Stock Item - May be secured through the Hardware Department of most Sears or Simpsons-Sears Retail Stores or Catalog Order Houses.

†† Ball Bearing has outer ring which must be removed in order to install.

repair parts

CRAFTSMAN BELT AND DISC SANDER MODEL NO. 113.225801 & 113.225831

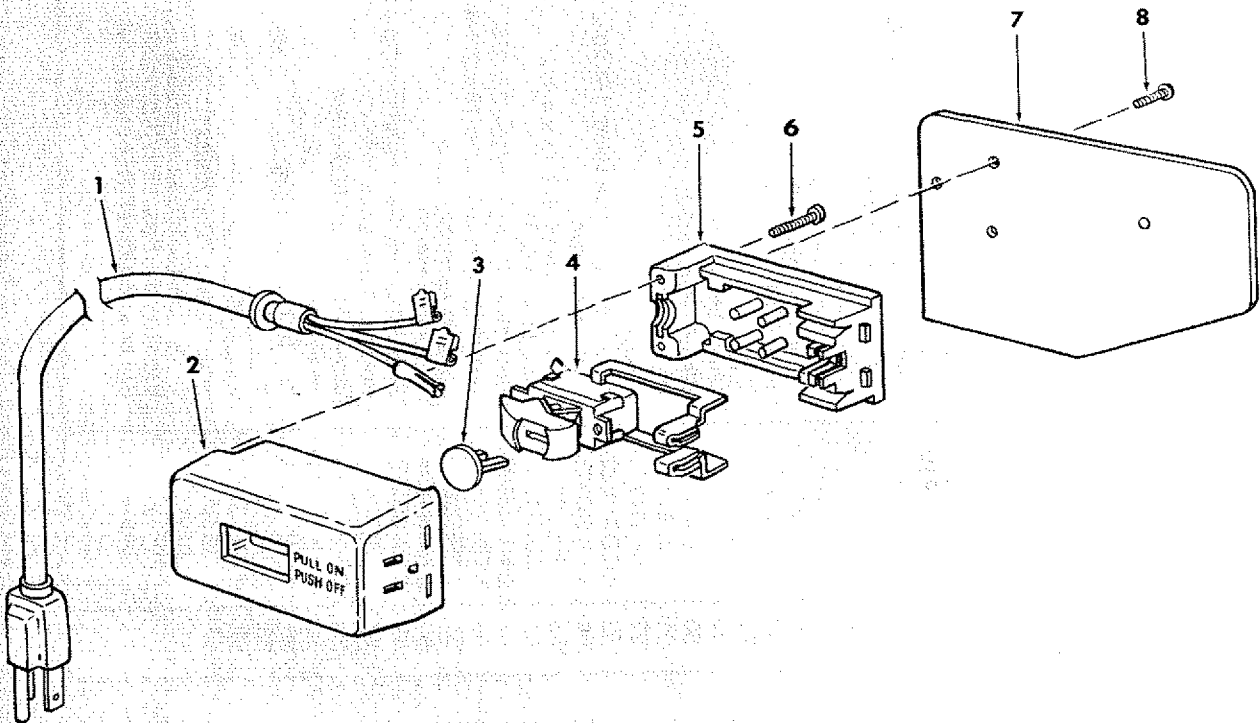

**FIGURE 2 PARTS LIST
ON/OFF POWER OUTLET 60382 AND MOUNTING BRACKET**

Key No.	Part No.	Description
—	60382	* On/Off Power Outlet Complete
1	60375	Cord, Molded
2	60378	Housing, Switch
3	60256	Key, Switch
4	60374	Switch, Locking
5	60376	Cover, Switch
6	448007	Screw, Pan Hd. No. 6 x 3/4
7	68011	Bracket, Switch Mounting
8	STD600803	*Screw, Pan Hd. Plastite No. 8 x 3/8

*Standard Hardware Item — May be Purchased Locally.

* Does Not Include Key No. 3.
Order Separately If Required.

NOTE: Shipping and handling charges for standard hardware items (identified by *) such as nuts, screws, washers, etc., make buying these items by mail uneconomical. To avoid shipping and handling charges, you may obtain most of these locally.

CRAFTSMAN BELT AND DISC SANDER MODEL NO. 113.225801 & 113.225831

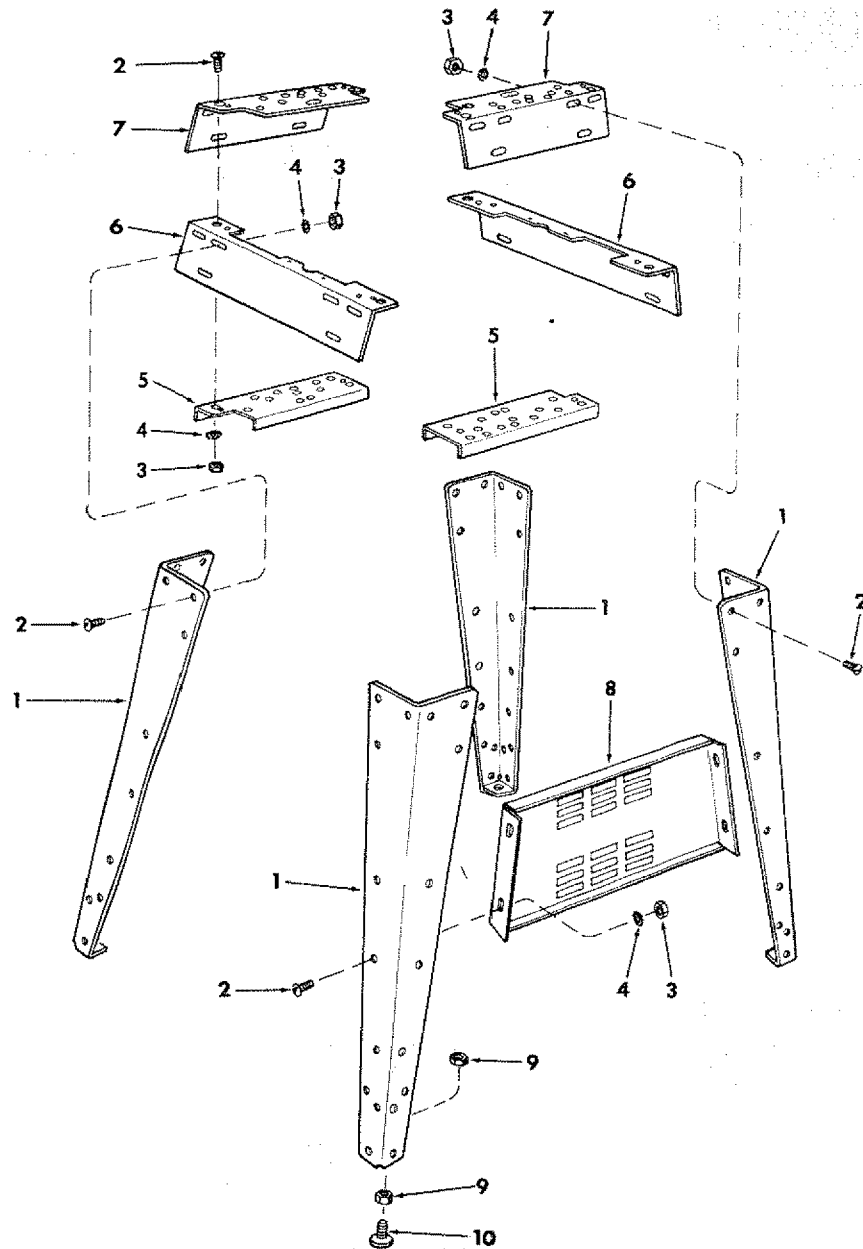

FIGURE 3 PARTS LIST
SUPPLIED WITH MODEL 113.225831 ONLY

Key No.	Part No.	Description
1	62614	Leg
2	60314	† Screw, Truss Hd. 1/4-20 x 5/8
3	STD541025	†* Nut, Hex 1/4-20
4	STD551225	†* Lockwasher, 1/4 External
5	68060	Channel, Support
6	68059	Stiffener, Side
7	62615	Stiffener, End
8	68061	Support, Motor
9	STD541050	†* Nut, Hex 1/2-13
10	803835	† Foot, Leveling
-	68062	† Bag of Loose Parts (Not illustrated)

Key No.	Part No.	Description
HARDWARE FOR MOUNTING TOOL & MOTOR		
-	STD523125	†*Screw, Hex Hd. 5/16-18 x 2-1/2
-	STD551131	†*Lockwasher, External 5/16
-	STD541231	†*Nut, Hex Jam 5/16 x 18
-	STD551031	†*Washer, 11/32 x 11/16 x 1/16
-	STD532507	†*Bolt, Carriage 5/16-18 x 3/4

†These items all contained in Loose Parts Bag, Part No. 68062.

*Standard Hardware Item - May be Purchased Locally.

Sears

*owners
manual*

SERVICE

**MODEL NO.
113.225801**

BELT AND DISC
SANDER ONLY

**MODEL NO.
113.225831**

BELT AND DISC
SANDER/WITH
LEGS AND MOTOR

**HOW TO ORDER
REPAIR PARTS**

BELT AND DISC SANDER

Now that you have purchased your Belt & Disc Sander should a need ever exist for repair parts or service, simply contact any Sears Service Center and most Sears, Roebuck and Co. stores. Be sure to provide all pertinent facts when you call or visit.

The model number of your Belt and Disc Sander will be found on a plate attached to your saw, at the right-hand side of the base.

WHEN ORDERING REPAIR PARTS, ALWAYS GIVE THE FOLLOWING INFORMATION:

PART NUMBER

PART DESCRIPTION

MODEL NUMBER
113.225801 OR
113.225831

NAME OF ITEM
Belt And Disc Sander

All parts listed may be ordered from any Sears Service Center and most Sears stores. If the parts you need are not stocked locally, your order will be electronically transmitted to a Sears Repair Parts Distribution Center for handling.

Sold by SEARS, ROEBUCK AND CO., Chicago, IL. 60684 U.S.A.