

**SEARS**

**OWNER'S  
MANUAL**

**MODEL NO.  
917.255560**

**Caution:**  
Read and follow  
all Safety Rules  
and Instructions  
Before Operating  
This Equipment



**CRAFTSMAN<sup>®</sup>**

**12.0 HP IC  
ELECTRIC START  
38" MOWER DECK  
5 SPEED TRANSAXLE  
LAWN TRACTOR**

- Assembly
- Operation
- Customer Responsibilities
- Service and Adjustment
- Repair Parts

---

Sears, Roebuck and Co., Chicago, IL 60684 U.S.A.

---



# SAFETY RULES

## Safe Operation Practices for Ride-On Mowers



**IMPORTANT: THIS CUTTING MACHINE IS CAPABLE OF AMPUTATING HANDS AND FEET AND THROWING OBJECTS FAILURE TO OBSERVE THE FOLLOWING SAFETY INSTRUCTIONS COULD RESULT IN SERIOUS INJURY OR DEATH**

### I. GENERAL OPERATION

- Read, understand, and follow all instructions in the manual and on the machine before starting.
- Only allow responsible adults, who are familiar with the instructions, to operate the machine.
- Clear the area of objects such as rocks, toys, wire, etc., which could be picked up and thrown by the blade.
- Be sure the area is clear of other people before mowing. Stop machine if anyone enters the area.
- Never carry passengers.
- Do not mow in reverse unless absolutely necessary. Always look down and behind before and while backing.
- Be aware of the mower discharge direction and do not point it at anyone. Do not operate the mower without either the entire grass catcher or the guard in place.
- Slow down before turning.
- Never leave a running machine unattended. Always turn off blades, set parking brake, stop engine, and remove keys before dismounting.
- Turn off blades when not mowing.
- Stop engine before removing grass catcher or unclogging chute.
- Mow only in daylight or good artificial light.
- Do not operate the machine while under the influence of alcohol or drugs.
- Watch for traffic when operating near or crossing roadways.
- Use extra care when loading or unloading the machine into a trailer or truck.

### II. SLOPE OPERATION

Slopes are a major factor related to loss-of-control and tipover accidents, which can result in severe injury or death. All slopes require extra caution. If you cannot back up the slope or if you feel uneasy on it, do not mow it.

#### DO:

- Mow up and down slopes, not across.
- Remove obstacles such as rocks, tree limbs, etc.
- Watch for holes, ruts, or bumps. Uneven terrain could overturn the machine. *Tall grass can hide obstacles.*
- Use slow speed. Choose a low gear so that you will not have to stop or shift while on the slope.
- Follow the manufacturer's recommendations for wheel weights or counterweights to improve stability.
- Use extra care with grass catchers or other attachments. These can change the stability of the machine.
- Keep all movement on the slopes *slow* and *gradual*. Do not make sudden changes in speed or direction.
- Avoid starting or stopping on a slope. If tires lose traction, disengage the blades and proceed slowly *straight* down the slope.

#### DO NOT:

- *Do not* turn on slopes unless necessary, and then, turn slowly and gradually downhill, if possible.
- *Do not* mow near drop-offs, ditches, or embankments. The mower could suddenly turn over if a wheel is over the edge of a cliff or ditch, or if an edge caves in.
- *Do not* mow on wet grass. Reduced traction could cause sliding.
- *Do not* try to stabilize the machine by putting your foot on the ground.
- *Do not* use grass catcher on steep slopes.

### III. CHILDREN

Tragic accidents can occur if the operator is not alert to the presence of children. Children are often attracted to the machine and the mowing activity. *Never* assume that children will remain where you last saw them.

- Keep children out of the mowing area and under the watchful care of another responsible adult.
- Be alert and turn machine off if children enter the area.
- Before and when backing, look behind and *down* for small children.
- Never carry children. They may fall off and be seriously injured or interfere with the safe machine operation.
- Never allow children to operate the machine.
- Use extra care when approaching blind corners, shrubs, trees, or other objects that may obscure vision.

### IV. SERVICE

- Use extra care in handling gasoline and other fuels. They are flammable and vapors are explosive.
  - Use only an approved container.
  - Never remove gas cap or add fuel with the engine running. Allow engine to cool before refueling. Do not smoke.
  - Never refuel the machine indoors.
  - Never store the machine or fuel container inside where there is an open flame, such as a water heater.
- Never run a machine inside a closed area.
- Keep nuts and bolts, especially blade attachment bolts, tight and keep equipment in good condition.
- Never tamper with safety devices. Check their proper operation regularly.
- Keep machine free of grass, leaves, or other debris build-up. Clean oil or fuel spillage. Allow machine to cool before storing.
- Stop and inspect the equipment if you strike an object. Repair, if necessary, before restarting.
- Never make adjustments or repairs with the engine running.
- Grass catcher components are subject to wear, damage, and deterioration, which could expose moving parts or allow objects to be thrown. Frequently check components and replace with manufacturer's recommended parts, when necessary.
- Mower blades are sharp and can cut. Wrap the blade(s) or wear gloves, and use extra caution when servicing them.
- Check brake operation frequently. Adjust and service as required.



Look for this symbol to point out important safety precautions. It means **CAUTION!!! BECOME ALERT!!! YOUR SAFETY IS INVOLVED.**



**CAUTION:** Always disconnect spark plug wire and place wire where it cannot contact spark plug in order to prevent accidental starting when setting up, transporting, adjusting or making repairs.

**CONGRATULATIONS** on your purchase of a Sears Tractor. It has been designed, engineered and manufactured to give you the best possible dependability and performance.

Should you experience any problem you cannot easily remedy, please contact your nearest Sears Service Center/Department. We have competent, well-trained technicians and the proper tools to service or repair this unit.

Please read and retain this manual. The instructions will enable you to assemble and maintain your unit properly. Always observe the "SAFETY RULES".

MODEL NUMBER	917.255560
SERIAL NUMBER	_____
DATE OF PURCHASE	_____
THE MODEL AND SERIAL NUMBERS WILL BE FOUND ON A PLATE UNDER THE SEAT.	
YOU SHOULD RECORD BOTH SERIAL NUMBER AND DATE OF PURCHASE AND KEEP IN A SAFE PLACE FOR FUTURE REFERENCE.	

## MAINTENANCE AGREEMENT

A Sears Maintenance Agreement is available on this product. Contact your nearest Sears store for details.

## CUSTOMER RESPONSIBILITIES

- Read and observe the safety rules.
- Follow a regular schedule in maintaining, caring for and using your unit.
- Follow the instructions under "Maintenance" and "Storage" sections of this owner's manual.

## PRODUCT SPECIFICATIONS

HORSEPOWER:	12.0
GASOLINE CAPACITY:	5 QUARTS UNLEADED REGULAR
OIL (3.0 PINTS):	SAE 30 (or 10W-30) WINTER: SAE 5W-30
SPARK PLUG (GAP .030 IN.):	CHAMPION RJ-19LM STD361458
VALVE CLEARANCE:	INTAKE .005 - .007 IN. EXHAUST .009 - .011 IN.
GROUND SPEED:	FORWARD 1st 1.10 MPH 2nd 2.00 MPH 3rd 3.00 MPH 4th 4.20 MPH 5th 5.00 MPH REVERSE: 1.50 MPH
TIRE PRESSURE:	FRONT: 14 PSI REAR: 10 PSI
CHARGING SYSTEM:	3 AMPS BATTERY 5 AMPS HEADLIGHTS
BLADE BOLT TORQUE:	30-35 FT. LBS.

**WARNING:** This unit is equipped with an internal combustion engine and should not be used on or near any unimproved forest-covered, brush-covered or grass-covered land unless the engine's exhaust system is equipped with a spark arrester meeting applicable local or state laws (if any). If a spark arrester is used, it should be maintained in effective working order by the operator.

In the state of California the above is required by law (Section 4442 of the California Public Resources Code). Other states may have similar laws. Federal laws apply on federal lands. A spark arrester for the muffler is available through your nearest Sears Authorized Service Center (See REPAIR PARTS section of this manual).

## LIMITED TWO YEAR WARRANTY ON ELECTRIC START RIDING EQUIPMENT

For two (2) years from the date of purchase, if this riding equipment is maintained, lubricated and tuned up according to the instructions in the owner's manual, Sears will repair or replace, free of charge, any parts found to be defective in material or workmanship.

This Warranty does not cover:

- Expendable items which become worn during normal use, such as blades, spark plugs, air cleaners and belts.
- Tire replacement or repair caused by punctures from outside objects, such as nails, thorns, stumps, or glass.
- Repairs necessary because of operator abuse, negligence, improper storage or accident or the failure to maintain the equipment according to the instructions contained in the owner's manual.
- Riding equipment used for commercial or rental purposes.

## LIMITED 90 DAY WARRANTY ON BATTERY

For 90 days from date of purchase, if any battery included with this riding equipment proves defective in material or workmanship and our testing determines the battery will not hold a charge, Sears will replace the battery at no charge.

WARRANTY SERVICE IS AVAILABLE BY RETURNING THE RIDING EQUIPMENT TO THE NEAREST SEARS SERVICE CENTER/DEPARTMENT IN THE UNITED STATES.

This Warranty gives you specific legal rights, and you may also have other rights which may vary from state to state.

SEARS, ROEBUCK AND CO., D/731CR-W, SEARS TOWER, CHICAGO, ILLINOIS 60684

# TABLE OF CONTENTS

SAFETY RULES .....	2	OPERATION .....	10-13
PRODUCT SPECIFICATIONS .....	3	MAINTENANCE SCHEDULE .....	14
CUSTOMER RESPONSIBILITIES .....	3, 14-17	SERVICE AND ADJUSTMENTS .....	18-23
WARRANTY .....	3	STORAGE .....	24
TABLE OF CONTENTS .....	4	TROUBLESHOOTING .....	25-26
INDEX .....	4	REPAIR PARTS - TRACTOR .....	28-43
TRACTOR ACCESSORIES .....	5	REPAIR PARTS - ENGINE .....	44-48
ASSEMBLY .....	7-9	PARTS ORDERING/SERVICE .....	BACK PAGE





## INDEX

<b>A</b>		<b>E</b>			
Accessories .....	5	Electrical:		Operation .....	10-13
Adjustments:		Interlocks and Relays .....	22	Operating Mower .....	12
Brake .....	20	Schematic .....	27	Options:	
Carburetor .....	23	Wiring Diagram .....	28	Accessories .....	5
Mower		Engine:		Spark Arrester .....	3,38
Front-To-Back .....	19	Air Filter .....	17	<b>P</b>	
Side-To-Side .....	19	Air Filter Foam Pre-Cleaner .....	17	Parking Brake .....	10-11
Throttle Control Cable .....	23	Air Screen .....	17	Parts Bag .....	6
Air Filter, Engine .....	17	Cooling Fins, Engine .....	17	Parts, Replacement/Repair .....	28-43
Air Screen, Engine .....	17	Oil Change .....	16	Product Specifications .....	3
Assembly .....	7-9	Oil Level .....	12,16	<b>R</b>	
		Oil Type .....	16	Repair Parts .....	28-43
<b>B</b>		Preparation .....	12	<b>S</b>	
Battery:		Repair Parts .....	44-48	Safety Rules .....	2
Charging .....	8	Starting .....	13	Seat .....	8
Cleaning .....	16	Storage .....	24	Service and Adjustments .....	18-23
Installation .....	9	<b>F</b>		Carburetor .....	23
Levels .....	8,16	Filter:		Fuse .....	22
Preparation .....	8	Air Filter .....	17	Hood Removal/Installation .....	22
Starting with Weak Battery .....	21	Air Filter Foam Pre-Cleaner .....	17	Motion Drive Belt	
Storage .....	24	Fuel .....	17	Removal/Replacement .....	20
Terminals .....	16	Fuel:		Mower Blade Drive Belt	
Belt:		Type .....	12	Removal/Replacement .....	20
Motion Drive		Storage .....	24	Mower Adjustment	
Removal/Replacement .....	20	Fuse .....	22	Front-to-Back .....	19
Mower Blade Drive		<b>H</b>		Side-to-Side .....	19
Removal/Replacement .....	20	Hood Removal/Installation .....	22	Mower Removal .....	18
Blade:		<b>L</b>		Tire Care .....	8,15,21
Sharpening .....	15	Leveling Mower Deck .....	19	Slope Guide Sheet .....	51
Replacement .....	15	Lubrication:		Spark Plugs .....	17
Brake Adjustment .....	20	Chart .....	14	Specifications .....	3
<b>C</b>		<b>M</b>		Starting the Engine .....	12-13
Carburetor Adjustment .....	24	Maintenance Schedule .....	14	Steering Wheel .....	7,21
Controls, Tractor .....	10	Mower:		Stopping the Tractor .....	11
Customer Responsibilities .....	14-17	Adjustment, Front-to-Back .....	19	Storage .....	24
Engine:		Adjustment, Side-to-Side .....	19	<b>T</b>	
Air Filter .....	17	Blade Sharpening .....	15	Throttle Control Cable	
Air Filter Foam Pre-Cleaner .....	17	Blade Replacement .....	15	Adjustment .....	23
Air Screen, Engine .....	17	Cutting Height .....	11	Tires .....	8,15,21
Battery .....	16	Installation .....	18	Trouble Shooting Chart .....	25-26
Cooling Fins, Engine .....	17	Operation .....	12	Transaxle:	
Engine Oil .....	16	Removal .....	18	Repair Parts .....	42-43
Fuel Filter .....	17	Mowing Tips .....	13	<b>W</b>	
Spark Plugs .....	17	Muffler .....	17	Warranty .....	3
Tractor:		Spark Arrester .....	3,38	Wiring Diagram .....	28
Blade .....	15	<b>O</b>		Wiring Schematic .....	28
Lubrication Chart .....	14	Oil:			
Maintenance Schedule .....	14	Cold Weather Conditions .....	12,16		
Tire Care .....	8,15,21	Engine .....	16		
Cutting Height, Mower .....	11	Storage .....	24		

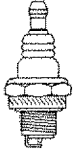
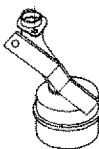

# ACCESSORIES AND ATTACHMENTS

These accessories and attachments were available when the unit was purchased. They are also available at most Sears retail outlets, catalog and service centers. Most Sears stores can order these items for you when you provide the model number of your tractor.

## ENGINE

SPARK PLUG	MUFFLER	AIR FILTER	GAS CAN	ENGINE OIL	STABILIZER
					

## MAINTENANCE

BLADES	BELTS
	

## PERFORMANCE

Sears offers a wide variety of attachments that fit your vehicle. Many of these are listed below with brief explanations of how they can help you. This list was current at the time of publication; however, it may change in future years - more attachments may be added, changes may be made in these attachments, or some may no longer be available or fit your model. Contact your nearest Sears store for the accessories and attachments that are available for your unit.

Most of these attachments do not require additional hitches or conversion kits (those that do are indicated) and are designed for easy attaching and detaching.

**PERMANEX BAGGER** lets you collect grass clippings and leaves for a healthier, neater looking lawn. Two Permanex containers hold 30-gallon plastic bags.

**LAWN SWEEPERS** let you collect grass clippings and leaves.

**LAWN VACS** for powerful collection of heavy grass clippings and leaves. Wand attachment to pick up debris in hard-to-reach places.

**CARTS** make hauling easy. Variety of sizes available.

**ROLLER** for smoother lawn surface. 36-inch wide, 18-inch diameter water-tight drum holds up to 390 lbs. of weight. Rounded edges prevent harm to turf. Adjustable scraper automatically cleans drum.

**SPREADER/SEEDERS** make seeding, fertilizing, and weed killing easy. Broadcast spreaders are also useful for granular de-icers and sand.

**CORING AERATOR** takes small plugs out of soil to allow moisture and nutrients to reach grass roots. 36-inch swath. 24 hardened steel coring tips. 150 lb. capacity weight tray.

**AERATOR** promotes deep root growth for a healthy lawn. Tapered 2.5-inch steel spikes mounted on 10-inch diameter discs puncture holes in soil at close intervals to let moisture soak in. Steel weight tray for increased penetration.

**MULCH RAKE/DETHATCHER** loosens soil and flips thatch and matted leaves to lawn surface for easy pickup. Twenty spring tine teeth. Useful to prepare bare areas for seeding. Available for front or rear mounting.

**SPRAYERS** use 12-volt DC electric motor that connects to the tractor battery or other 12-volt source. Includes booms for automatic spraying when pulling, and hand held wand for spot spraying. Wand has adjustable spray pattern. For applying herbicides, insecticides, fungicides, and liquid fertilizers.

**SNOW BLADE** for snow removal only. 14-inch high, 42-inch wide blade clears 38-inch path when angled left or right. Raises, lowers with side lever. Adjustable skids; replaceable, reversible scraper bar. (Use with tire chains, wheel weights, or rear drawbar weight.)

**SNOWTHROWER** has 40-inch swath. Drum-type auger handles powdery and wet/heavy snow. Mounts easily with simple pin arrangement. Discharge chute adjusts from tractor seat. 6-inch diameter spout discharges snow 10 to 50 feet. Lift controlled at tractor seat. (Use with chains, wheel weights, or rear drawbar weight.)

**TIRE CHAINS** are heavy duty; closely spaced extra-large cross links give smooth ride, outstanding traction.

**WHEEL WEIGHTS** for rear wheels provide needed traction for snow removal or dozing heavy materials. In pairs. (30 lbs. each.)

**TRACTOR CAB** has heavy duty vinyl fabric over tubular steel frame, ABS plastic top; clear plastic windshield offers 360 degree visibility. Hinged metal doors with catch. Keeps operator warm and dry. Remove vinyl and windshields for use as sun protector in summer. (Catalog only.)

**Optional accessories for tractor cab:** tinted/tempered solid safety glass windshield with hand operated wiper; 12-volt amber caution light for mounting on cab top. (Catalog only.)

**TRACTOR COVER** protects tractor from weather. Made of Evolution 3 fabric (water-repellent, extremely breathable, light weight, soft, non-abrasive, pliable in all temperatures, durable, stain/tear/puncture resistant, will not shrink or stretch.) (Catalog only.)

# CONTENTS OF HARDWARE PACK

## Parts Bag contents shown full size

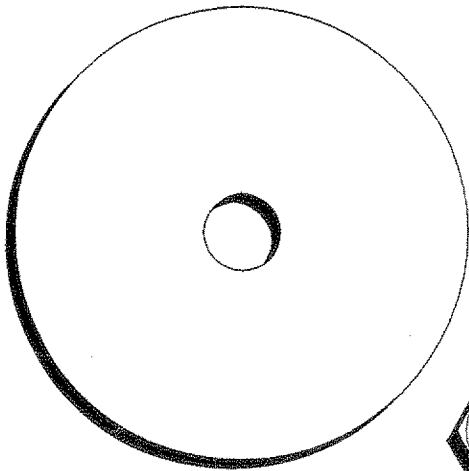

(1) 2-3/8" Dia. Washer

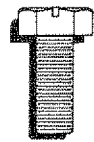

(2) Sheet Metal Screws #10-16 x 1/2

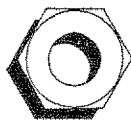

(1) Locknut 3/8-24

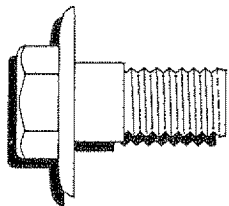

(1) Shoulder Bolt 5/16-18

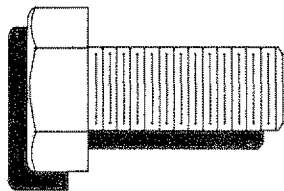

(1) Hex Bolt 1/2-13 x 1

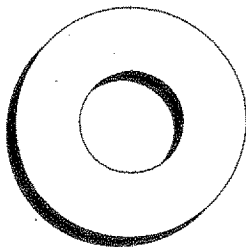

(1) Washer 17/32 x 1-3/16 x 12 Ga.

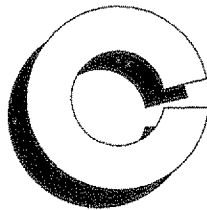

(1) Lock Washer 1/2



(2) Hex Bolts 1/4 - 20 x 3/4



(2) Hex Nuts 1/4 - 20



(2) Washers 9/32 x 5/8 x 16 Ga.



(2) Lock Washers 1/4

## Parts packed separately in carton

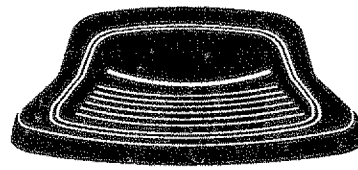

Seat

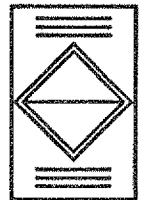

Battery acid

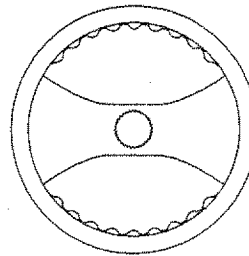

Steering Wheel

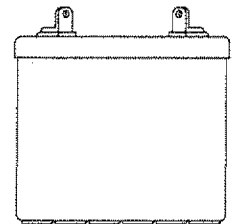

Battery



Steering Boot



Owner's Manual

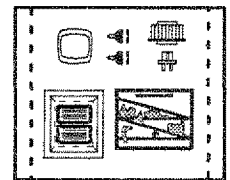

Parts Bag

## Parts bag contents not shown full size

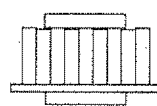

Steering Wheel Adapter

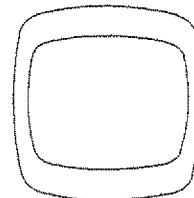

Steering Wheel Insert



Steering Bushing



(2) Keys

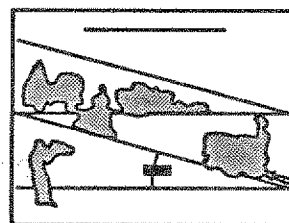

15° Slope Sheet

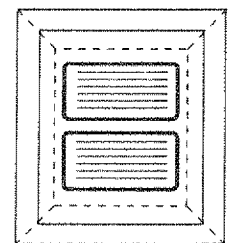

Battery Caps and Instructions

# ASSEMBLY

## TOOLS REQUIRED FOR ASSEMBLY

A socket wrench set will make assembly easier. Standard wrench sizes are listed.

- |                    |                     |
|--------------------|---------------------|
| (1) 5/16" wrench   | Tire pressure gauge |
| (2) 7/16" wrenches | Screwdriver         |
| (1) 1/2" wrench    | Utility knife       |
| (1) 9/16" wrench   |                     |

When right and left hand is mentioned in this manual, it means when you are in the operating position (seated behind the steering wheel).

## TO REMOVE UNIT FROM CARTON

### UNPACK CARTON

- Remove all accessible loose parts and parts cartons from carton (See page 6).
- Cut along dotted lines on carton, from top to bottom, all four corners of carton and lay panels flat.
- Check for any additional loose parts or cartons and remove.

## BEFORE ROLLING UNIT OFF SKID

### ATTACH STEERING WHEEL (See Fig. 1)

- Slide the steering bushing over the steering shaft.
- Raise steering shaft forward until screw holes in dash line up with steering bushing. Install two (2) sheet metal screws and tighten securely.
- Position steering boot over steering shaft.
- Place tabs of steering boot over slots in dash and push down to secure.
- Slide steering wheel adapter onto upper steering shaft.
- Position front wheels of the tractor so they are pointing straight forward.
- Position steering wheel so cross bars are horizontal (left to right) and slide onto adapter.
- Assemble large flat washer and 3/8-24 hex locknut and tighten securely.
- Snap insert into center of steering wheel.
- Remove protective plastic from tractor hood and grill.

**IMPORTANT: CHECK FOR AND REMOVE ANY STAPLES IN SKID THAT MAY PUNCTURE TIRES WHERE UNIT IS TO ROLL OFF SKID.**

### (See Fig. 6)

- Raise attachment lift lever to its highest position.
- Release parking brake by depressing clutch/brake pedal.
- Place gearshift lever in "NEUTRAL" position.
- Roll unit backwards off skid.
- Remove banding holding discharge guard up against tractor.

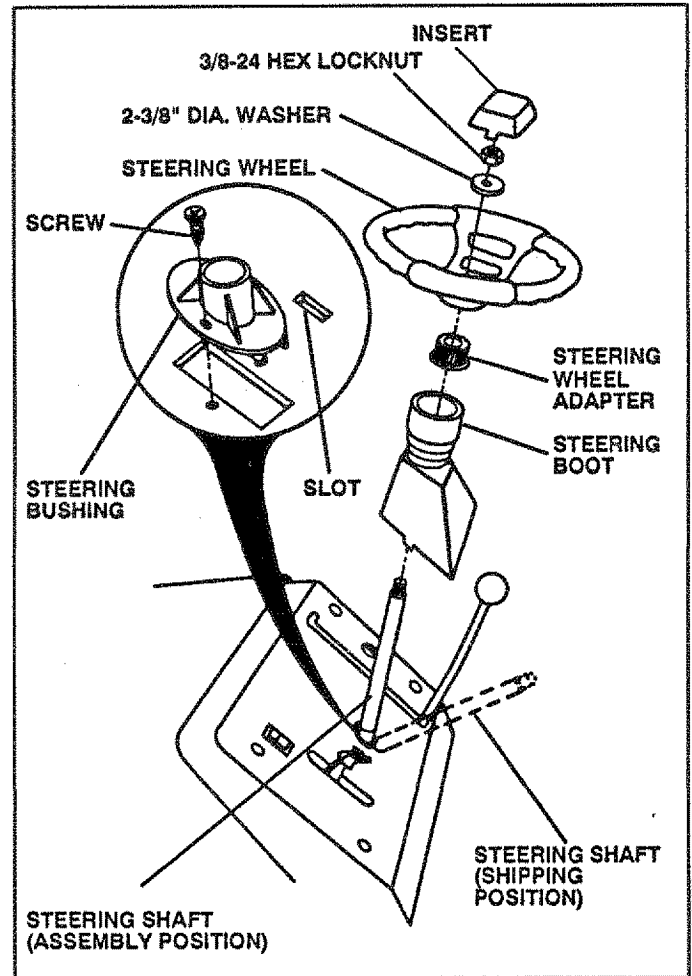

FIG. 1

# ASSEMBLY

## HOW TO SET UP YOUR TRACTOR PREPARE BATTERY (See Fig. 2)

**CAUTION: Wear eye and face shield.**

Wash hands or clothing immediately if accidentally in contact with battery acid.

Do not smoke. Fumes from charged battery acid are explosive.

Read the instructions included with the battery vent caps. Always wear gloves, clothing and goggles to protect your hands, skin and eyes.



Your unit has a battery charging system which is sufficient for normal use. However, periodic charging of the battery with an automotive charger will extend its life.

- See instructions packed with vent caps in parts bag.
- Fill battery with acid. Fill each cell until it reaches the bottom of the vent wells. Do not overfill.
- Allow battery to stand and settle for at least thirty minutes. After standing, check the level of acid. If below the vent wells, add more acid until the correct level is reached.

While battery is standing (after adding acid) and later, while battery is being charged, continue with assembly of unit.

**IMPORTANT: TO MAXIMIZE THE LIFE OF YOUR BATTERY, IT IS NECESSARY THAT THE BATTERY BE CHARGED BEFORE USE. FAILURE TO CHARGE BATTERY CAN RESULT IN A SHORTENED BATTERY LIFE.**

- Charge battery at a rate of 6 amperes for 1 hour. Use a 12 volt battery charger. Observe all safety precautions required for battery charging.
- Check the acid level after the battery is charged. If the acid has fallen below the correct level, add distilled or iron free water.
- Install the vent caps to cover the vent wells. Wash the top of the battery with water to remove any acid, then wipe dry.
- Check battery case for leakage to make sure that no damage has occurred in handling.
- Dispose of excess battery acid. Neutralize acid for disposal by adding it to four inches of water in a five gallon plastic container. Stir with a wooden or plastic paddle while adding baking soda until the addition of more soda causes no more foaming.
- Follow instructions on how to install battery.

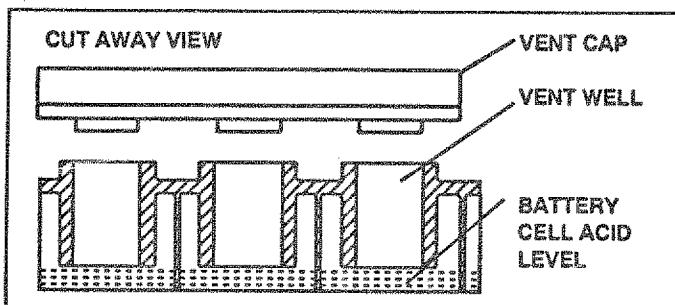

FIG. 2

## INSTALL SEAT (See Fig. 3)

Adjust seat before tightening adjustment bolt.

- Remove cardboard packing on seat pan.
- Place seat on pan and assemble shoulder bolt.
- Assemble adjustment bolt, lock washer and flat washer loosely. Do not tighten.
- Tighten shoulder bolt securely.
- Lower seat into operating position and sit on seat.
- Slide seat until a comfortable position is reached which allows you to press clutch/brake pedal all the way down (See Fig. 6).
- Get off seat without moving its adjusted position.
- Raise seat and tighten adjustment bolt securely.

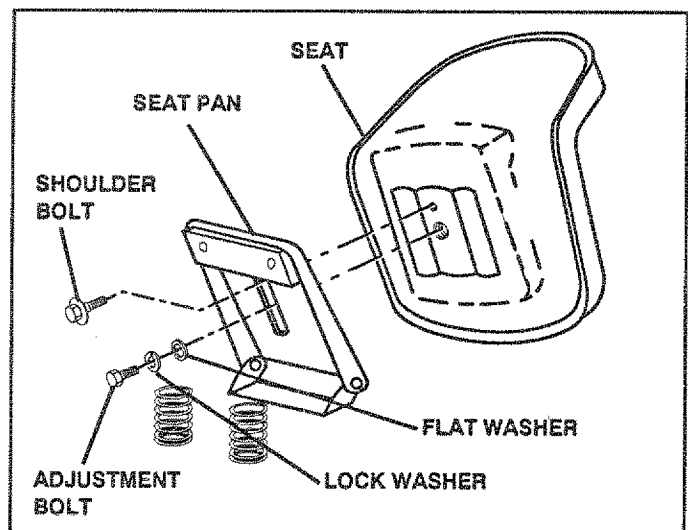

FIG. 3

## CHECK TIRE PRESSURE

The tires on your unit were overinflated at the factory for shipping purposes. Correct tire pressure is important for best cutting performance.

- Reduce tire pressure to PSI shown in "PRODUCT SPECIFICATIONS" on page 3 of this manual.

## CHECK DECK LEVELNESS

For best cutting results, mower housing should be properly leveled. See "TO LEVEL MOWER HOUSING" in the Service and Adjustments section of this manual.

## CHECK FOR PROPER POSITION OF ALL BELTS

See the figures that are shown for replacing motion and mower blade drive belts in the Service and Adjustments section of this manual. Verify that the belts are routed correctly.

## CHECK BRAKE SYSTEM

After you learn how to operate your tractor, check to see that the brake is properly adjusted. See "TO ADJUST BRAKE" in the Service and Adjustments section of this manual.



# ASSEMBLY

## INSTALL BATTERY (See Figs. 4 & 5)



**CAUTION:** Do not short battery terminals. Before installing battery, remove metal bracelets, wristwatch bands, rings, etc.

Positive terminal must be connected first to prevent sparking from accidental grounding.

- Lift seat to raised position.
- Open battery box door.
- Lower battery into battery box with battery terminals toward front of unit.
- Be sure battery drain tube is attached to battery box.
- First connect RED battery cable to positive (+) battery terminal with hex bolt, flat washer, lock washer and hex nut as shown. Tighten securely.
- Connect BLACK grounding cable to negative (-) battery terminal with remaining hex bolt, flat washer, lock washer and hex nut. Tighten securely.
- Close battery box door.

Open battery box door for:

- Inspection for secure connections (to tighten hardware).
- Inspection for corrosion.
- Testing battery.
- Jumping (if required).
- Periodic charging .

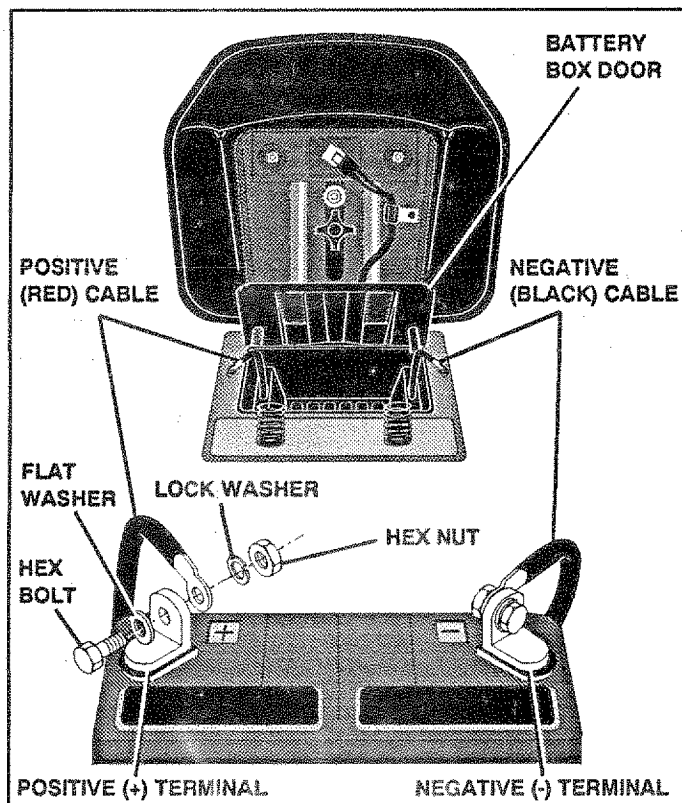

FIG. 4

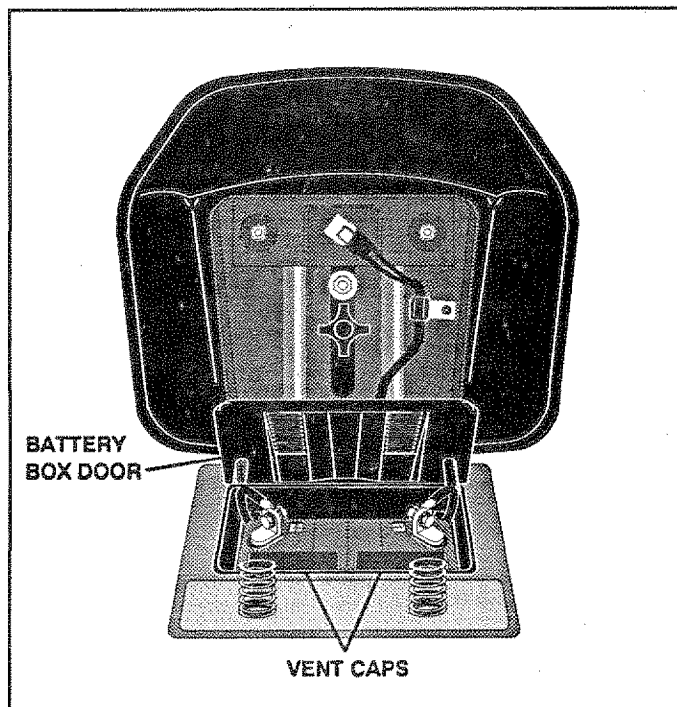

FIG. 5

## ✓ CHECKLIST

*BEFORE YOU OPERATE AND ENJOY YOUR NEW TRACTOR, WE WISH TO ASSURE THAT YOU RECEIVE THE BEST PERFORMANCE AND SATISFACTION FROM THIS QUALITY PRODUCT.*

*PLEASE REVIEW THE FOLLOWING CHECKLIST:*

- ✓ All assembly instructions have been completed.
- ✓ No remaining loose parts in carton.
- ✓ Battery is properly prepared and charged. (Minimum 1 hour at 6 amps).
- ✓ Seat is adjusted comfortably and tightened securely.
- ✓ All tires are properly inflated. (For shipping purposes, the tires were over-inflated at the factory).
- ✓ Be sure mower deck is properly leveled side-to-side/front-to-rear for best cutting results. (Tires must be properly inflated for leveling).
- ✓ Check mower and drive belts. Be sure they are routed properly around pulleys and inside all belt keepers.
- ✓ Check wiring. See that all connections are still secure and wires are properly clamped.

*WHILE LEARNING HOW TO USE YOUR TRACTOR, PAY EXTRA ATTENTION TO THE FOLLOWING IMPORTANT ITEMS:*

- ✓ Engine oil is at proper level.
- ✓ Fuel tank is filled with fresh, clean, regular unleaded gasoline.
- ✓ Become familiar with all controls - their location and function. Operate them before you start the engine.
- ✓ Be sure brake system is in safe operating condition.

# OPERATION

## KNOW YOUR TRACTOR

### READ THIS OWNER'S MANUAL AND SAFETY RULES BEFORE OPERATING YOUR TRACTOR

Compare the illustrations with your tractor to familiarize yourself with the locations of various controls and adjustments. Save this manual for future reference.

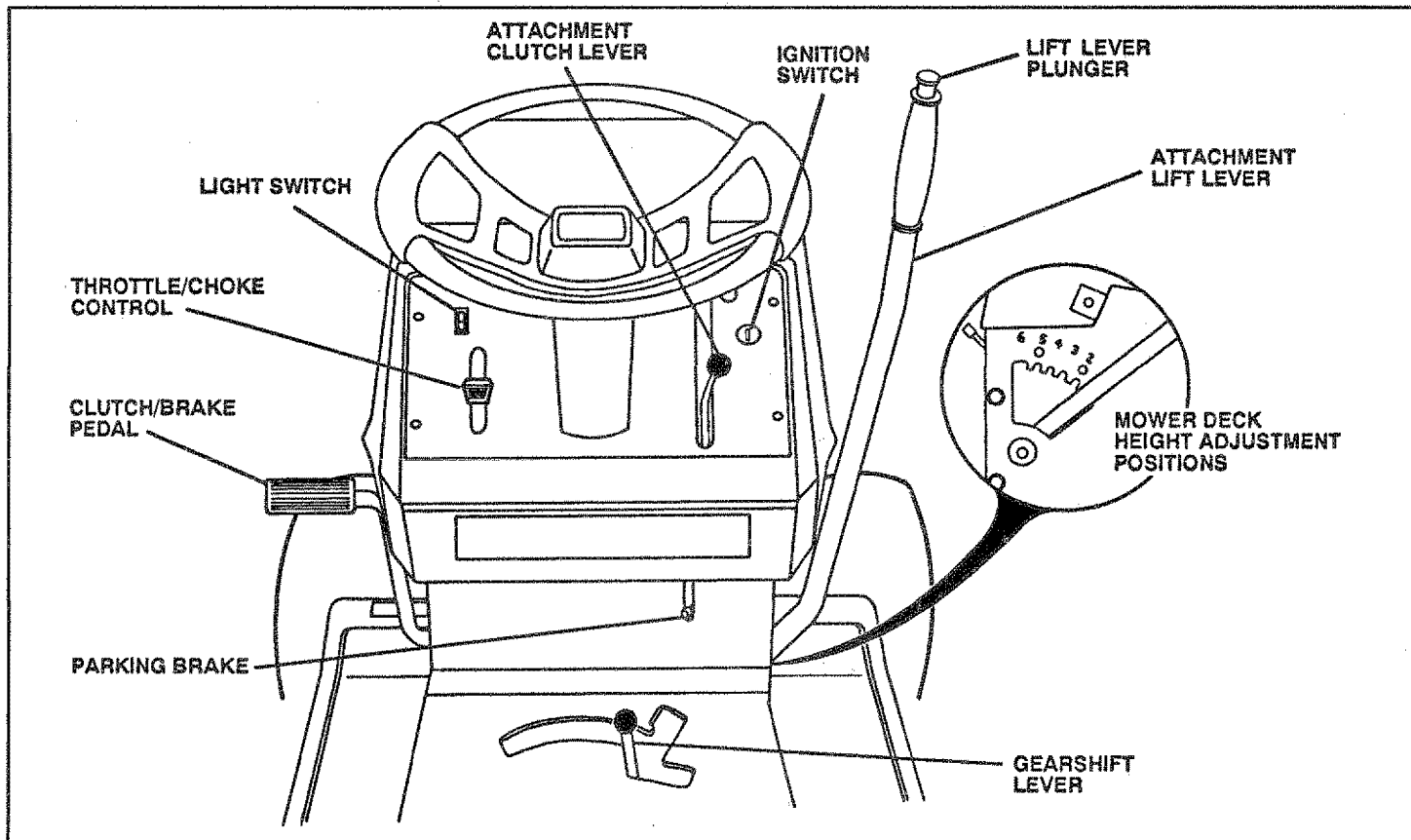

FIG. 6

Sears tractors conform to the safety standards of the American National Standards Institute.

**ATTACHMENT CLUTCH LEVER:** Used to engage the mower blades, or other attachments mounted to your tractor.

**LIGHT SWITCH:** Turns the headlights on and off.

**THROTTLE/CHOKE CONTROL:** Used for starting and controlling engine speed.

**CLUTCH/BRAKE PEDAL:** Used for declutching and braking the tractor and starting the engine.

**PARKING BRAKE:** Locks clutch/brake pedal into the brake position.

**GEARSHIFT LEVER:** Selects the speed and direction of tractor.

**ATTACHMENT LIFT LEVER:** Used to raise, lower, and adjust the mower deck or other attachments mounted to your tractor.

**LIFT LEVER PLUNGER:** Used to release attachment lift lever when changing its position.

**IGNITION SWITCH:** Used for starting and stopping the engine.

# OPERATION



The operation of any tractor can result in foreign objects thrown into the eyes, which can result in severe eye damage. Always wear safety glasses or eye shields while operating your tractor or performing any adjustments or repairs. We recommend wide vision safety mask for over the spectacles or standard safety glasses, available at Sears Retail or Catalog stores.

## HOW TO USE YOUR TRACTOR TO SET PARKING BRAKE (See Fig. 7)

- Depress clutch/brake pedal into full "BRAKE" position and hold.
- Place parking brake lever in "ENGAGED" position and release pressure from clutch/brake pedal. Pedal should remain in "BRAKE" position. Make sure parking brake will hold vehicle secure.

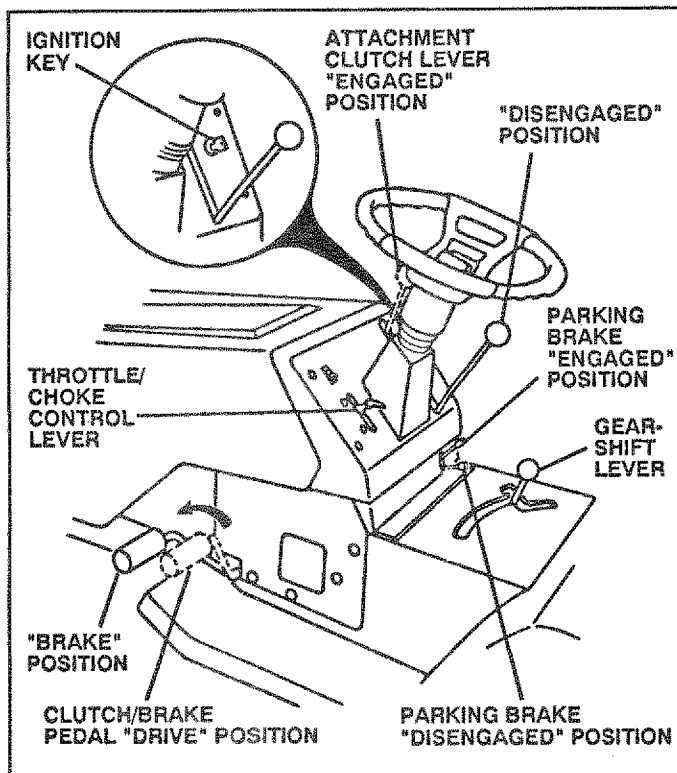

FIG. 7

## STOPPING (See Fig. 7)

### MOWER BLADES -

- Move attachment clutch lever to "DISENGAGED" position.

### GROUND DRIVE -

- Depress clutch/brake pedal into full "BRAKE" position.
- Move gearshift lever to "NEUTRAL" position.

### ENGINE -

- Move throttle control to "SLOW" position.
- Turn ignition key to "OFF" position and remove key. Always remove key when leaving vehicle to prevent unauthorized use.
- Never use choke to stop engine.

**NOTE:** Under certain conditions when unit is standing idle with the engine running, hot engine exhaust gases may cause "browning" of grass. To eliminate this possibility, always stop engine when stopping unit on grass areas.



**CAUTION:** Always stop unit completely, as described above, before leaving the operator's position; to empty grass catcher, etc.

## TO USE THROTTLE CONTROL (See Fig. 7)

Always operate engine at full throttle.

- Operating engine at less than full throttle reduces the battery charging rate and the engine cooling air flow.
- Full throttle offers the best bagging and mower performance.

## TO MOVE FORWARD AND BACKWARD (See Fig. 6)

The direction and speed of movement is controlled by the gearshift lever.

- Start tractor with clutch/brake pedal depressed and gearshift lever in "NEUTRAL" position.
- Move gearshift lever to desired position.
- Slowly release clutch/brake pedal to start movement.

**IMPORTANT:** BRING TRACTOR TO A COMPLETE STOP BEFORE SHIFTING OR CHANGING GEARS. FAILURE TO DO SO WILL SHORTEN THE USEFUL LIFE OF YOUR TRANSAXLE.

## TO ADJUST MOWER CUTTING HEIGHT (See Fig. 6)

The position of the attachment lift lever determines the cutting height.

- Grasp lift lever.
- Press plunger with thumb and move lever to desired position.

The cutting height range is approximately 1-1/2 to 4". The heights are measured from the ground to the blade tip with the engine not running. These heights are approximate and may vary depending upon soil conditions, height of grass and types of grass being mowed.

- The average lawn should be cut approximately 2-1/2 inches during the cool season and over 3 inches during hot months. For healthier and better looking lawns, mow often and after moderate growth.
- For best cutting performance, grass over 6 inches in height should be mowed twice. Make the first cut relatively high; the second to desired height.

# OPERATION

## TO OPERATE MOWER (See Fig. 8)

Your unit is equipped with an operator presence sensing switch. Any attempt by the operator to leave the seat with the engine running and the attachment clutch engaged will shut off the engine.

- Select desired height of cut.
- Engage mower by slowly moving attachment clutch lever to "ENGAGED" position.
- **TO STOP MOWER** - Move attachment clutch lever to "DISENGAGED" position.



**CAUTION:** Do not operate the mower without either the entire grass catcher, on mowers so equipped, or the discharge guard in place.

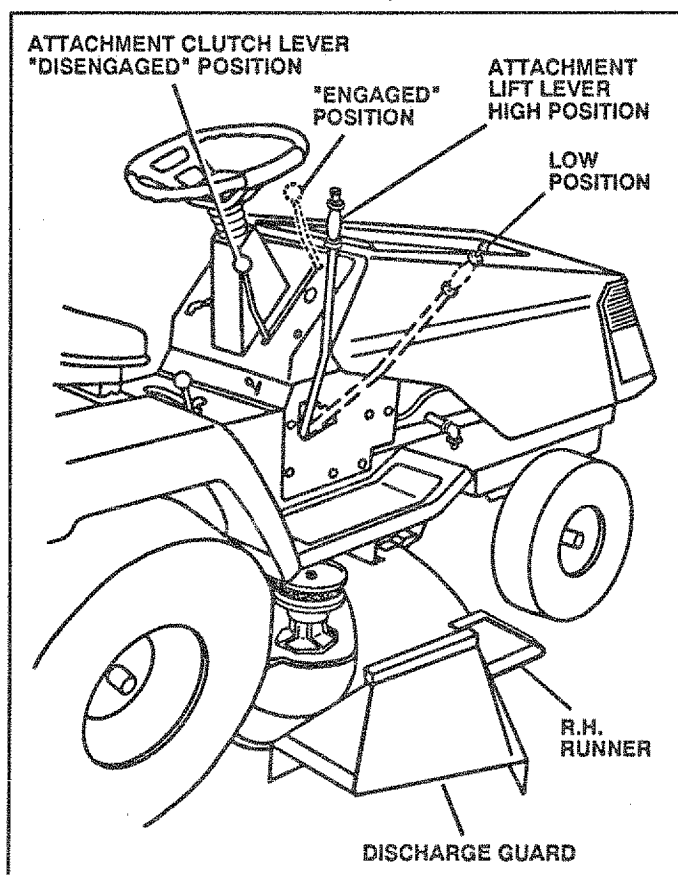

FIG. 8

## TO OPERATE ON HILLS



**CAUTION:** Do not drive up or down hills with slopes greater than 15° and do not drive across any slope.

- Choose the slowest speed before starting up or down hills.
- Avoid stopping or changing speed on hills.
- If slowing is necessary, move throttle control lever to slower position.

- If stopping is absolutely necessary, push clutch/brake pedal quickly to brake position and engage parking brake.
- Move gearshift lever to 1st gear and be sure you have allowed room for tractor to roll slightly as you restart movement.
- To restart movement, slowly release parking brake and clutch/brake pedal.
- Make all turns slowly.

## TO TRANSPORT

- Raise attachment lift control to highest position.
- When pushing or towing your unit, be sure gearshift lever is in "NEUTRAL" position.
- Do not push or tow unit at more than five (5) MPH.

## BEFORE STARTING THE ENGINE

### CHECK ENGINE OIL LEVEL (See Fig. 13)

- The engine in your unit has been shipped, from the factory, already filled with summer weight oil.
- Check engine oil with unit on level ground.
- Remove oil fill dipstick and wipe clean, replace and screw cap tight, wait for a few seconds, remove and read oil level. If necessary, add oil until "FULL" mark on dipstick is reached. Do not overfill.
- For cold weather operation you should change oil for easier starting (see "OIL VISCOSITY CHART" in the Customer Responsibilities section of this manual).
- To change engine oil, see the Customer Responsibilities section in this manual.

### ADD GASOLINE

- Fill fuel tank. Use fresh, clean, regular unleaded gasoline. (Use of leaded gasoline will increase carbon and lead oxide deposits and reduce valve life).

**IMPORTANT:** WHEN OPERATING IN TEMPERATURES BELOW 32°F (0°C), USE FRESH, CLEAN WINTER GRADE GASOLINE TO HELP INSURE GOOD COLD WEATHER STARTING.

**WARNING:** Experience indicates that alcohol blended fuels (called gasohol or using ethanol or methanol) can attract moisture which leads to separation and formation of acids during storage. Acidic gas can damage the fuel system of an engine while in storage. To avoid engine problems, the fuel system should be emptied before storage of 30 days or longer. Drain the gas tank, start the engine and let it run until the fuel lines and carburetor are empty. Use fresh fuel next season. See Storage Instructions for additional information. Never use engine or carburetor cleaner products in the fuel tank or permanent damage may occur.



**CAUTION:** Fill to bottom of gas tank filler neck. Do not overfill. Wipe off any spilled oil or fuel. Do not store, spill or use gasoline near an open flame.

# OPERATION

## TO START ENGINE (See Fig. 7)

When starting engine for the first time or if engine has run out of fuel, it will take extra cranking time to move fuel from the tank to the engine.

- Depress the clutch/brake pedal and set the parking brake.
- Place gearshift lever in "NEUTRAL" position.
- Move attachment clutch to "DISENGAGED" position.
- Move throttle control lever to "CHOKE" position for cold engine start. For warm engine start, move throttle control to "FAST" position.
- Turn ignition key clockwise to "START" position and release key as soon as engine starts. Do not run starter continuously for more than fifteen seconds per minute. If engine does not start after several attempts, move throttle control to "FAST" position, wait a few minutes and try again.
- When engine starts, move throttle control to desired position.
- Allow engine to warm up for a few minutes before engaging drive or attachment clutch.

**NOTE:** If at a high altitude (above 3000 feet) or in cold temperatures (below 32° F), the carburetor fuel mixture may need to be adjusted for best engine performance. See "TO ADJUST CARBURETOR" in the Service and Adjustments section of this manual.

## MOWING TIPS

- Tire chains cannot be used when the mower housing is attached to unit.
- Mower should be properly leveled for best mowing performance. See "TO LEVEL MOWER HOUSING" in the Service and Adjustments section of this manual.
- Use the runner on the right hand side of mower as a guide. The blade cuts approximately an inch outside the runner (See Fig. 8).
- The left hand side of mower should be used for trimming.

- Drive so that clippings are discharged onto the area that has been cut. Have the cut area to the right of the machine. This will result in a more even distribution of clippings and more uniform cutting.
- When mowing large areas, start by turning to the right so that clippings will discharge away from shrubs, fences, driveways, etc. After one or two rounds, mow in the opposite direction making left hand turns until finished (See Fig. 9).

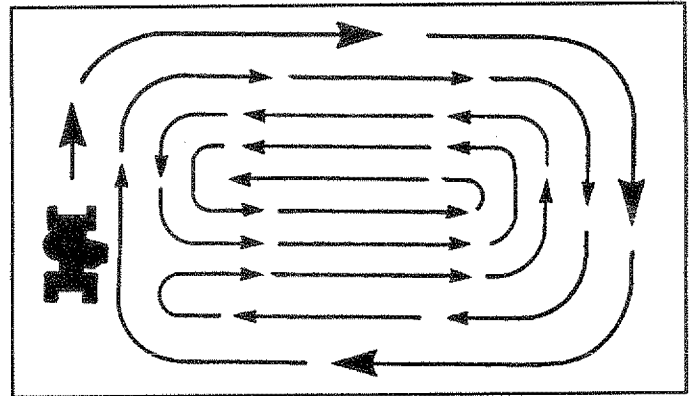

FIG. 9

- If grass is extremely tall, it should be mowed twice to reduce load and possible fire hazard from dried clippings. Make first cut relatively high; the second to the desired height.
- Do not mow grass when it is wet. Wet grass will plug mower and leave undesirable clumps. Allow grass to dry before mowing.
- Always operate engine at full throttle when mowing to assure better mowing performance and proper discharge of material. Regulate ground speed by selecting a low enough gear to give the mower cutting performance as well as the quality of cut desired.
- When operating attachments, select a ground speed that will suit the terrain and give best performance of the attachment being used.

# CUSTOMER RESPONSIBILITIES

MAINTENANCE SCHEDULE FILL IN DATES AS YOU COMPLETE REGULAR SERVICE		SERVICE INTERVALS							SERVICE DATES		
		BEFORE EACH USE	FIRST 2 HOURS	EVERY 8 HOURS	EVERY 25 HOURS	EVERY 50 HOURS	EVERY 100 HOURS	BEFORE SEASON			BEFORE STORAGE
TRACTOR	Check Brake Operation	✓		✓							
	Check Tire Pressure	✓		✓							
	Check for Loose Fasteners	✓							✓		
	Sharpen/Replace Mower Blades				✓ <sub>4</sub>						
	Lubrication Chart				✓				✓		
	Check Battery Level/Recharge				✓						
	Clean Battery and Terminals				✓				✓		
	Check Transmission Cooling				✓						
	Adjust Blade Belt(s) Tension						✓				
	Adjust Motion Drive Belt(s) Tension						✓				
ENGINE	Check Engine Oil Level	✓		✓							
	Change Engine Oil		✓		✓ <sub>1,2,3</sub>				✓		
	Clean Air Filter				✓ <sub>2</sub>						
	Clean Air Screen				✓ <sub>2</sub>						
	Inspect Muffler/Spark Arrester					✓					
	Replace Oil Filter (If equipped)						✓ <sub>1,2</sub>				
	Clean Engine Cooling Fins						✓ <sub>2</sub>				
	Replace Spark Plug						✓		✓		
	Replace Air Filter Paper Cartridge						✓ <sub>2</sub>				
Replace Fuel Filter								✓			

1 - Change more often when operating under a heavy load or in high ambient temperatures.  
2 - Service more often when operating in dirty or dusty conditions.

3 - If equipped with oil filter, change oil every 50 hours.  
4 - Replace blades more often when mowing in sandy soil.

## GENERAL RECOMMENDATIONS

The warranty on this vehicle does not cover items that have been subjected to operator abuse or negligence. To receive full value from the warranty, operator must maintain unit as instructed in this manual.

Some adjustments will need to be made periodically to properly maintain your unit.

All adjustments in the Service and Adjustments section of this manual should be checked at least once each season.

- Once a year you should replace the spark plug, clean or replace air filter, and check blades and belts for wear. A new spark plug and clean air filter assure proper air-fuel mixture and help your engine run better and last longer.

## BEFORE EACH USE

- Check engine oil level.
- Check brake operation.
- Check tire pressure.
- Check for loose fasteners.

## LUBRICATION CHART

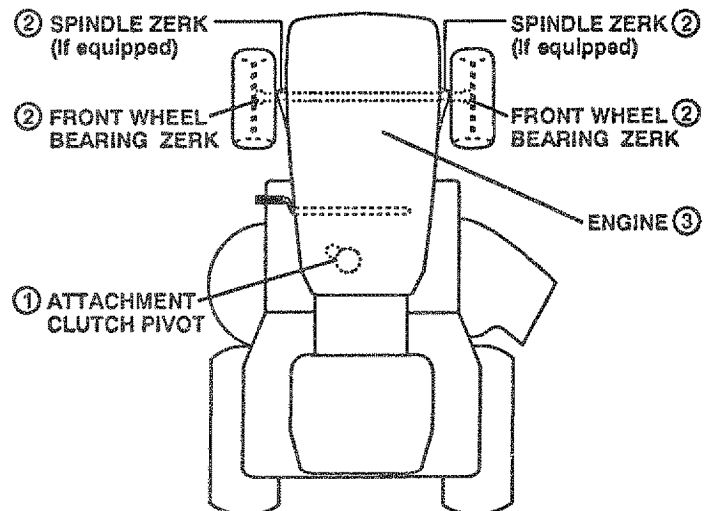

① SAE 30 OR 10W30 MOTOR OIL API - SG

② GENERAL PURPOSE GREASE

③ REFER TO CUSTOMER RESPONSIBILITIES "ENGINE" SECTION

**IMPORTANT:** DO NOT OIL OR GREASE THE PIVOT POINTS WHICH HAVE SPECIAL NYLON BEARINGS. VISCOUS LUBRICANTS WILL ATTRACT DUST AND DIRT THAT WILL SHORTEN THE LIFE OF THE SELF-LUBRICATING BEARINGS. IF YOU FEEL THEY MUST BE LUBRICATED, USE ONLY A DRY, POWDERED GRAPHITE TYPE LUBRICANT SPARINGLY.

# CUSTOMER RESPONSIBILITIES

## TRACTOR

Always observe safety rules when performing any maintenance.

## BRAKE OPERATION

If unit requires more than six (6) feet stopping distance at high speed in highest gear, than brake must be adjusted. (See "TO ADJUST BRAKE" in Service and Adjustments section of this manual).

## TIRES

- Maintain proper air pressure in all tires (See "PRODUCT SPECIFICATIONS" on page 3 of this manual).
- Keep tires free of gasoline, oil, or insect control chemicals which can harm rubber.
- Avoid stumps, stones, deep ruts, sharp objects and other hazards that may cause tire damage.

## BLADE CARE

For best results mower blades must be kept sharp. The blades can be sharpened with a file or on a grinding wheel. We suggest they be sharpened or replaced after every 25 hours of mowing. Check blades more often if mowing in sandy conditions.

- Do not attempt to sharpen blades while they are on the mower.
- Replace bent or damaged blades.

## BLADE REMOVAL (See Fig. 10)

- Raise mower to highest position to allow access to blades.
- Remove hex bolt, lock washer and flat washer securing blade.
- Install new or resharpened blade with trailing edge up towards deck as shown.
- Reassemble hex bolt, lock washer and flat washer in exact order as shown.
- Tighten bolt securely (30-35 Ft. Lbs. torque).

**IMPORTANT: BLADE BOLT IS GRADE 8 HEAT TREATED.**

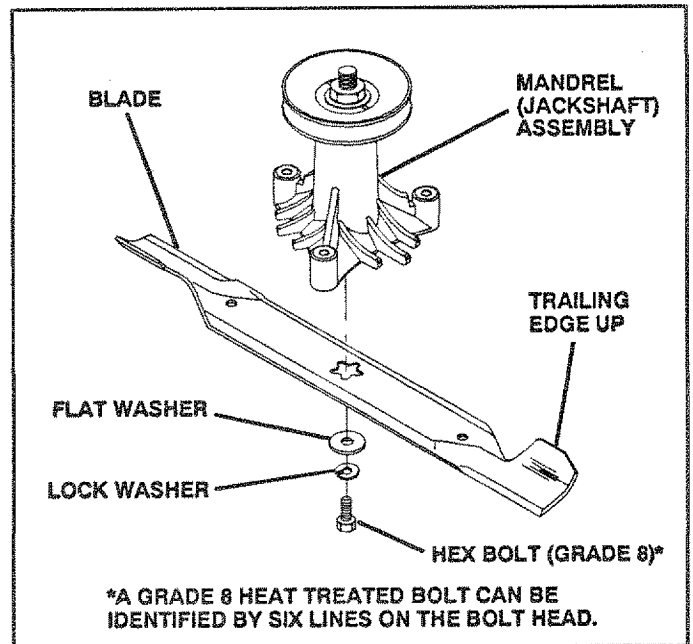

FIG. 10

## TO SHARPEN BLADE (See Fig. 11)

Care should be taken to keep the blade balanced. An unbalanced blade will cause excessive vibration and eventual damage to mower and engine.

- The blade can be sharpened with a file or on a grinding wheel. Do not attempt to sharpen while on the mower.
- To check blade balance, you will need a 5/8" diameter steel bolt, pin, or a cone balancer. (When using a cone balancer, follow the instructions supplied with balancer).
- Slide blade on to an unthreaded portion of the steel bolt or pin and hold the bolt or pin parallel with the ground. If blade is balanced, it should remain in a horizontal position. If either end of the blade moves downward, sharpen the heavy end until the blade is balanced.

**NOTE:** Do not use a nail for balancing blade. The lobes of the center hole may appear to be centered, but are not.

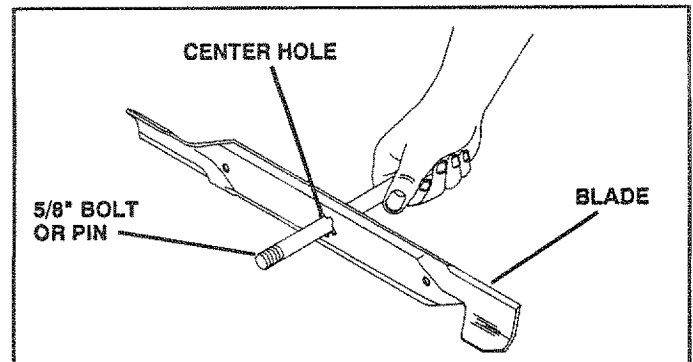

FIG. 11

# CUSTOMER RESPONSIBILITIES

## BATTERY (See Fig. 12)

Your unit has a battery charging system which is sufficient for normal use. However, periodic charging of the battery with an automotive charger will extend its life.

- Acid solution level in each battery cell should be even with bottoms of vent wells. Add only distilled or iron free water if necessary. Do not overfill.

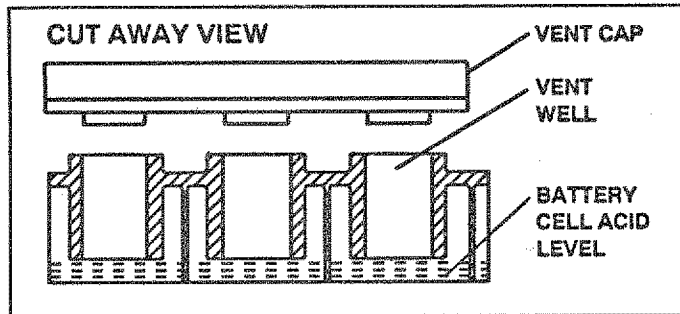

FIG. 12

- Keep battery and terminals clean.
- Keep battery bolts tight.
- Keep vent caps tight and small vent holes in caps open.
- Recharge at 6 amperes for 1 hour.

### TO CLEAN BATTERY AND TERMINALS -

Corrosion and dirt on the battery and terminals can cause the battery to "leak" power.

- Remove terminal guard.
- Disconnect BLACK battery cable first then RED battery cable and remove battery from tractor.
- Wash battery with solution of four tablespoons of baking soda to one gallon of water. Be careful not to get the soda solution into the cells.
- Rinse the battery with plain water and dry.
- Clean terminals and battery cable ends with wire brush until bright.
- Coat terminals with grease or petroleum jelly.
- Reinstall battery (See "INSTALL BATTERY" in the Assembly section of this manual).

## V-BELTS

Check V-belts for deterioration and wear after 100 hours and replace if necessary. The belts are not adjustable. Replace belts if they begin to slip from wear.

## TRANSAXLE COOLING

Keep transaxle free from build-up of dirt and chaff which can restrict cooling.

## ENGINE

### LUBRICATION

Change the oil after the first two hours of operation and every 25 hours thereafter or at least once a year if the tractor is not used for 25 hours in one year.

Check the crankcase oil level before starting the engine and after each eight (8) hours of continuous use. Add SAE 30W motor oil or equivalent. Tighten oil fill cap/dipstick securely each time you check the oil level. SAE 5W-30 motor oil may be used to make starting easier in areas where temperature is consistently 32° F or lower.

### TO CHANGE ENGINE OIL (See Fig. 13)

Determine temperature range expected before oil change. All oil must meet API service classification SG.

- Be sure vehicle is on level surface.
- Oil will drain more freely when warm.
- Catch oil in a suitable container.
- Remove oil fill dipstick. Be careful not to allow dirt to enter the engine when changing oil.
- Remove drain plug.
- After oil has drained completely, replace oil drain plug and tighten securely.
- Refill engine with oil through oil fill dipstick tube. Pour slowly. Do not overfill. For approximate capacity see Product Specifications on page 3 of this manual.
- Use gauge on oil fill dipstick for checking level. Be sure dipstick cap is tightened securely for accurate reading. Keep oil at "FULL" line on dipstick.

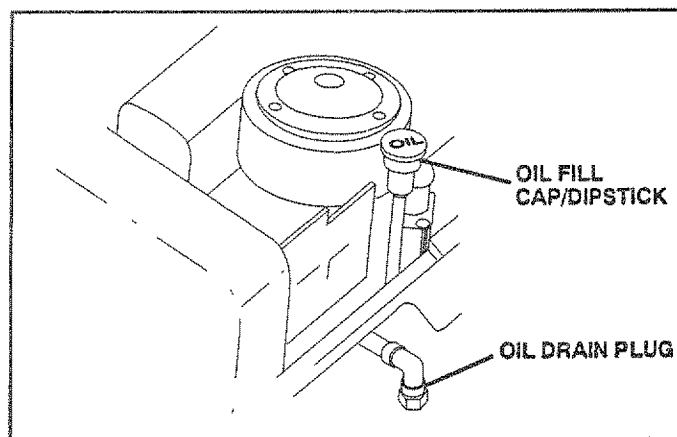
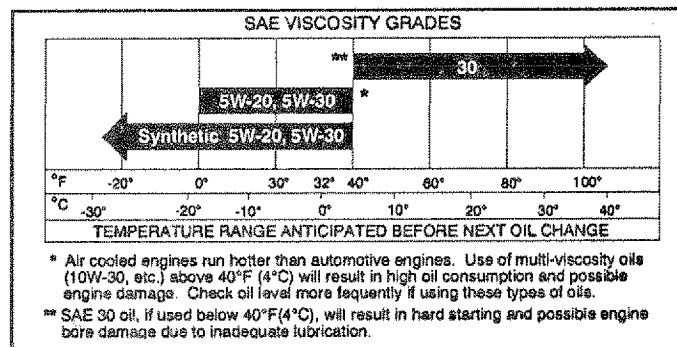

FIG. 13



# CUSTOMER RESPONSIBILITIES

## AIR FILTER FOAM PRE-CLEANER (See Fig. 14)

Your engine will not run properly and may be damaged by using a dirty air filter. Clean the foam pre-cleaner element after every 25 hours of operation, more often if used in very dusty, dirty conditions.

- Remove knob and cover.
- Remove cartridge nut and replace cartridge.
- Reassemble and tighten securely.

**NOTE:** Do not attempt to clean or oil the paper cartridge. Replace paper cartridge once a year or after every 100 hours of operation, more often if used in very dusty, dirty conditions.

- Wash foam pre-cleaner in liquid detergent and water.
- Wrap foam pre-cleaner in cloth and squeeze dry.
- Lightly coat foam pre-cleaner with clean engine oil. Squeeze in towel to remove excess oil. Do not saturate.
- Install foam pre-cleaner over paper cartridge.
- Reassemble cover and secure with knobs.

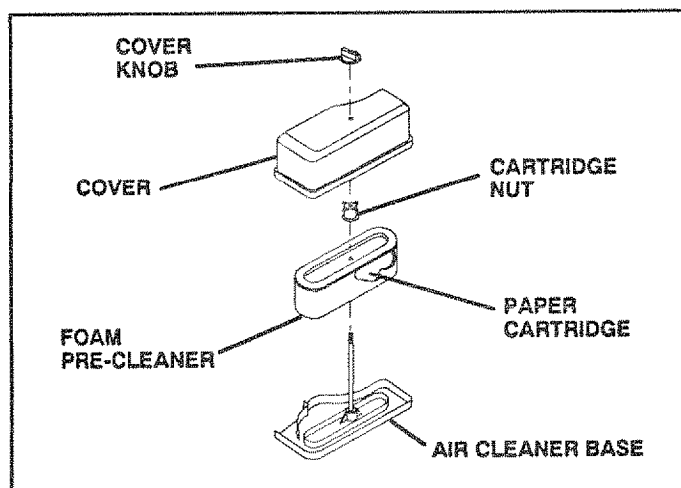

FIG. 14

## AIR SCREEN (See Fig. 15)

The engine air screen must be kept free of dirt and chaff to prevent engine damage from overheating. Clean with a wire brush or compressed air to remove dirt and stubborn dried gum fibers.

## ENGINE COOLING FINS (See Fig. 15)

Remove any dust, dirt or oil from engine cooling fins to prevent engine damage from overheating.

- Remove oil fill dipstick and cover opening to prevent entry of dirt.
- Remove screws from blower housing and lift housing off engine.
- Remove the screws securing the starter housing and lift housing off engine.
- Use compressed air or stiff bristle brush to thoroughly clean engine cooling fins.
- To reassemble, reverse above procedure.

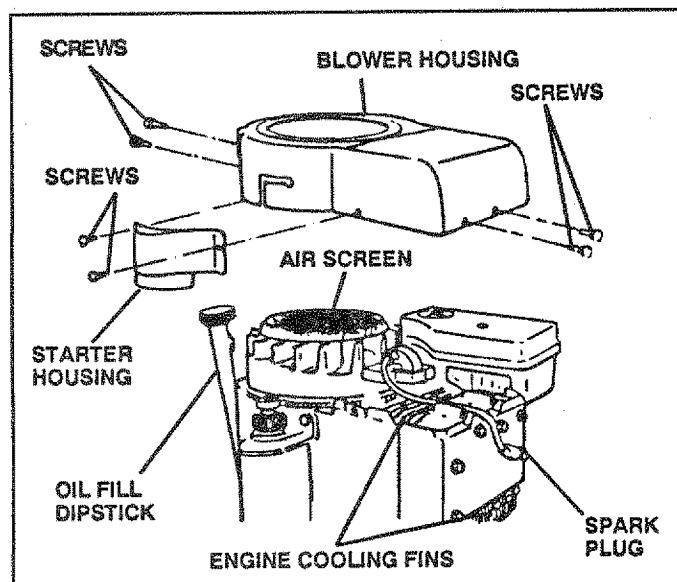

FIG. 15

## MUFFLER

Inspect and replace corroded muffler and spark arrester (if equipped) as it could create a fire hazard and/or damage.

## SPARK PLUGS

Replace spark plugs at the beginning of each mowing season or after every 100 hours of use, whichever comes first. Spark plug type and gap setting is shown in "PRODUCT SPECIFICATIONS" on page 3 of this manual.

## IN-LINE FUEL FILTER (See Fig. 16)

Fuel filter should be replaced once each season. If fuel filter becomes clogged, obstructing fuel flow to carburetor, replacement is required.

- With engine cool, remove filter and plug fuel line sections.
- Place new fuel filter in position in fuel line.
- Be sure there are no fuel line leaks and clamps are properly positioned.
- Immediately wipe up any spilled gasoline.

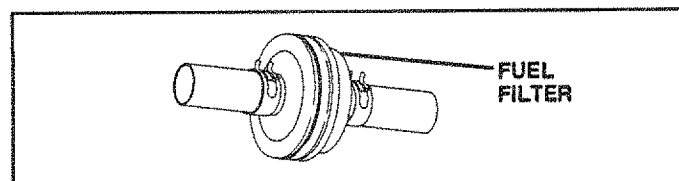

FIG. 16

## CLEANING

- Clean engine, battery, seat, finish, etc. of all foreign matter.
- Keep finished surfaces and wheels free of all gasoline, oil, etc.
- Protect painted surfaces with automotive type wax.

We do not recommend using a garden hose to clean your unit unless the electrical system, muffler, air filter and carburetor are covered to keep water out. Water in engine can result in a shortened engine life.

# SERVICE AND ADJUSTMENTS



## CAUTION: BEFORE PERFORMING ANY SERVICE OR ADJUSTMENTS:

- Depress clutch/brake pedal fully and set parking brake.
- Place gearshift lever in "NEUTRAL" position.
- Place attachment clutch in "DISENGAGED" position.
- Turn ignition key "OFF" and remove key.
- Make sure the blades and all moving parts have completely stopped.
- Disconnect spark plug wire from spark plug and place wire where it cannot come in contact with plug.

## TRACTOR

### TO REMOVE MOWER (See Fig. 17)

Mower will be easier to remove from the right side of unit.

- Place attachment clutch in "DISENGAGED" position.
- Move attachment lift lever forward to lower mower to its lowest position.
- Roll belt off engine pulley.
- Disconnect clutch rod from clutch lever by removing retainer spring.
- Disconnect suspension arms from rear deck brackets by removing retainer springs.
- Disconnect front links from deck by removing retainer springs.
- Raise lift lever to raise suspension arms. Slide mower out from under tractor.

**IMPORTANT:** IF AN ATTACHMENT OTHER THAN THE MOWER IS TO BE MOUNTED TO THE TRACTOR, THE R.H. AND L.H. SUSPENSION ARMS MUST BE REMOVED FROM TRACTOR.

### TO INSTALL MOWER (See Fig. 17)

- Raise attachment lift lever to its highest position.
- Slide mower under tractor with discharge guard to right side of tractor.
- Lower lift lever to its lowest position.
- Install mower in reverse order of removal instructions.

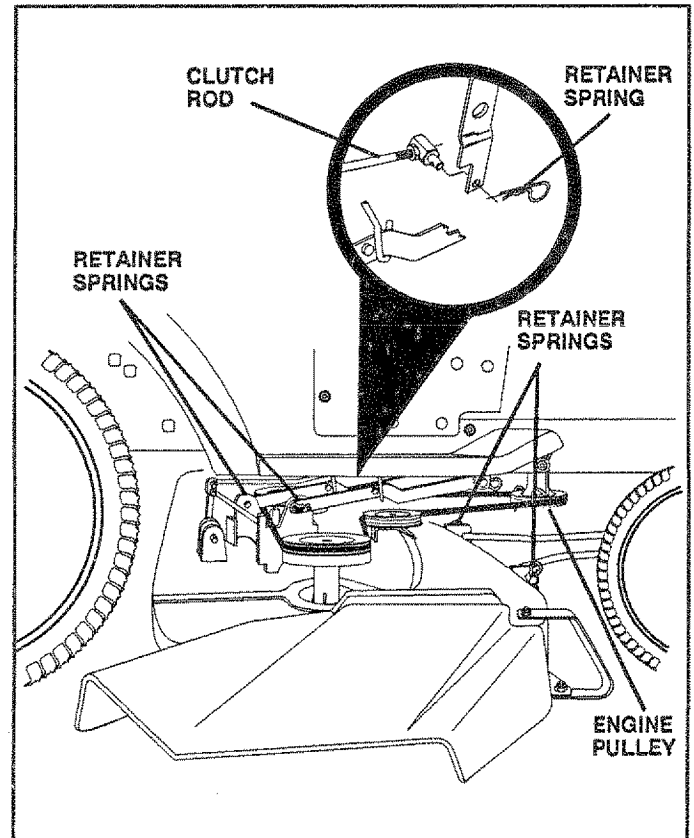

FIG. 17

# SERVICE AND ADJUSTMENTS

## TO LEVEL MOWER HOUSING

Adjust the mower while tractor is parked on level ground or driveway. Make sure tires are properly inflated (See "PRODUCT SPECIFICATIONS" on page 3). If tires are over or under inflated, you will not properly adjust your mower.

### SIDE-TO-SIDE ADJUSTMENT (See Figs.18 and19) -

- Raise attachment lift lever to its highest position.
- Measure height from bottom of deck curl to ground level at front corners of mower. Distance "A" should be the same.
- If distance "A" needs to be changed, snap out access hole cover on left side of tractor above footrest.
- To raise left side of mower, loosen nut "B" and tighten nut "C".
- To lower left side of mower, loosen nut "C" and tighten nut "B".
- When distance "A" is equal, securely tighten nuts "B" and "C".
- Replace access hole cover.

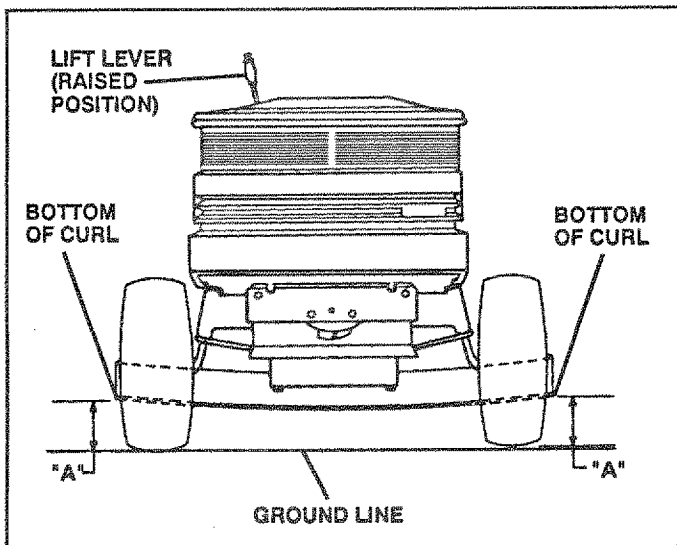

FIG. 18

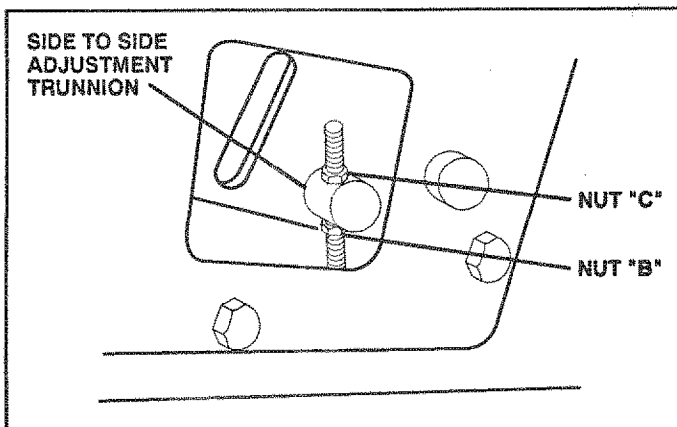

FIG. 19

**FRONT-TO-BACK ADJUSTMENT (See Figs. 20 and 21) -**  
To obtain the best cutting results, the mower housing should be adjusted so that the front is approximately 3/8" to 1/2" lower than the rear when the mower is in its highest position.

Check adjustment on right side of tractor. Measure distance "D" at front and rear flanges of mower housing as shown.

- To lower front of mower turn nut "E" counterclockwise on both front links an equal number of turns.
- When distance "D" is 3/8" to 1/2" lower at front than rear, tighten nuts "F" against trunnion on both front links.
- To raise front of mower, loosen nut "F" from trunnion on both front links. Turn nut "E" clockwise on both front links an equal number of turns.
- When distance "D" is 3/8" to 1/2" lower at front than rear, retighten nut "F" against trunnion on both front links.

**IMPORTANT: WHEN ADJUSTING FRONT LINK TRUNNIONS, ALWAYS ADJUST BOTH EQUALLY SO MOWER WILL STAY LEVEL SIDE-TO-SIDE.**

- Recheck side-to-side adjustment.

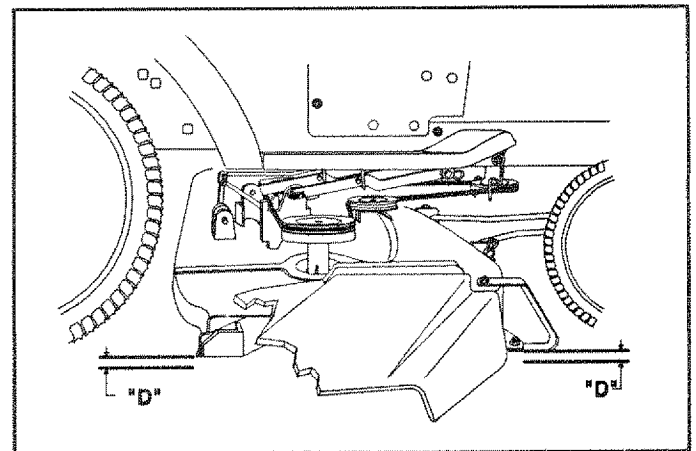

FIG. 20

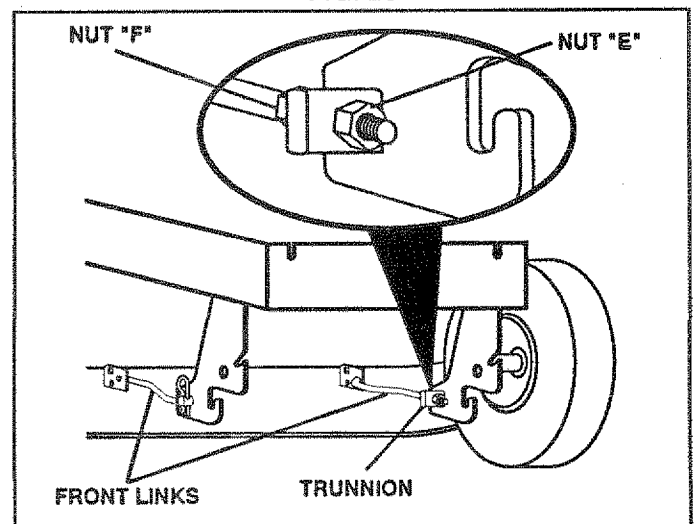

FIG. 21

# SERVICE AND ADJUSTMENTS

## TO REPLACE MOWER BLADE DRIVE BELT (See Fig. 22)

The mower blade drive belt may be replaced without tools. Park the tractor on level surface. Engage parking brake. For assistance, there is a belt installation guide decal on the mower housing.

### BELT REMOVAL -

- Place attachment clutch in "DISENGAGED" position.
- Move attachment lift lever forward to lower mower to its lowest position.
- Roll belt off engine pulley.
- Disconnect R.H. suspension arm from rear deck bracket by removing retainer spring.
- Work belt off both mandrel pulleys and idler pulleys.
- Pull belt away from mower.

### BELT INSTALLATION -

- Install new belt in reverse order of removal.
- Make sure belt is in all pulley grooves and inside all belt guides.

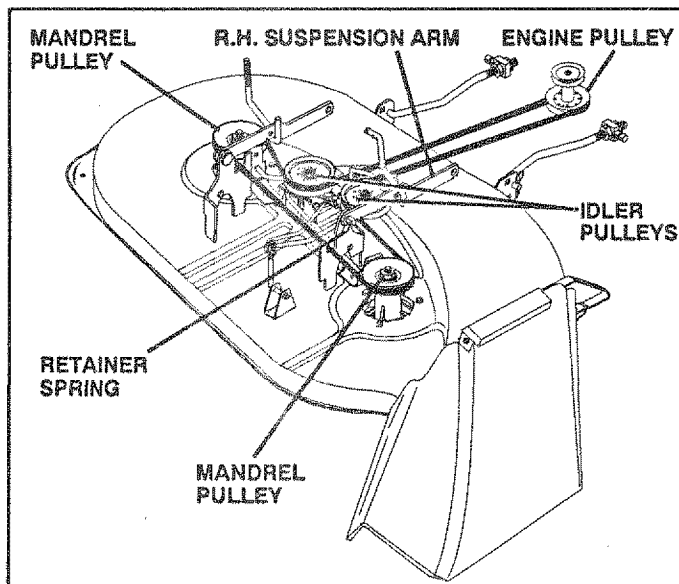

FIG. 22

## TO ADJUST BRAKE (See Fig. 23)

Your unit is equipped with an adjustable brake system which is mounted on the right side of the transaxle.

If unit requires more than six (6) feet stopping distance at high speed in highest gear, then brake must be adjusted.

- Depress clutch/brake pedal and engage parking brake.
- Measure distance between brake operating arm and nut "A" on brake rod.
- If distance is other than 1-1/2", disengage parking brake, loosen jam nut and turn nut "A" until distance becomes 1-1/2". Retighten jam nut against nut "A".
- Engage parking brake and recheck distance.
- Road test unit for proper stopping distance as stated above. Readjust if necessary. If stopping distance is still greater than six (6) feet in highest gear, further maintenance is necessary. Contact your nearest authorized service center.

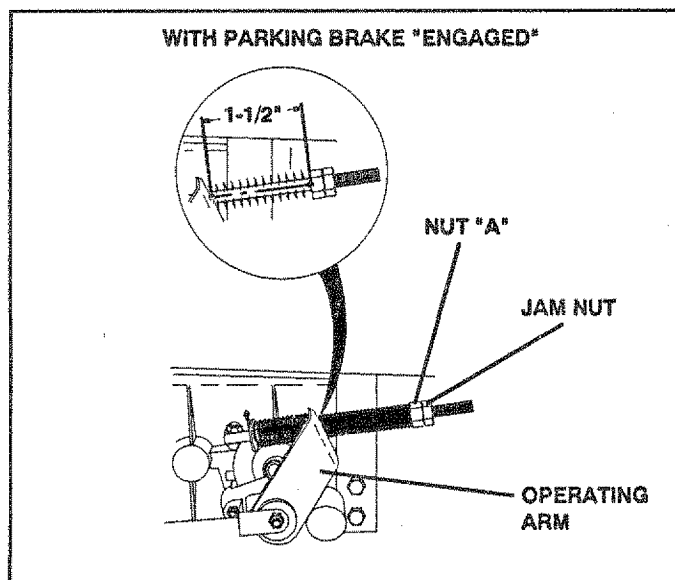

FIG. 23

## TO REPLACE MOTION DRIVE BELT (See Fig. 24)

Park the tractor on level area. Engage parking brake. For assistance, there is a belt installation guide decal on bottom side of left footrest.

- Remove mower (See "TO REMOVE MOWER" in this section of this manual).
- Remove belt from stationary idler and clutching idler.
- Remove belt from engine pulley.
- Roll belt over top of transaxle pulley.
- Install new belt by reversing above procedure.

**IMPORTANT: REPLACE ONLY WITH BELT LISTED IN THIS MANUAL.**

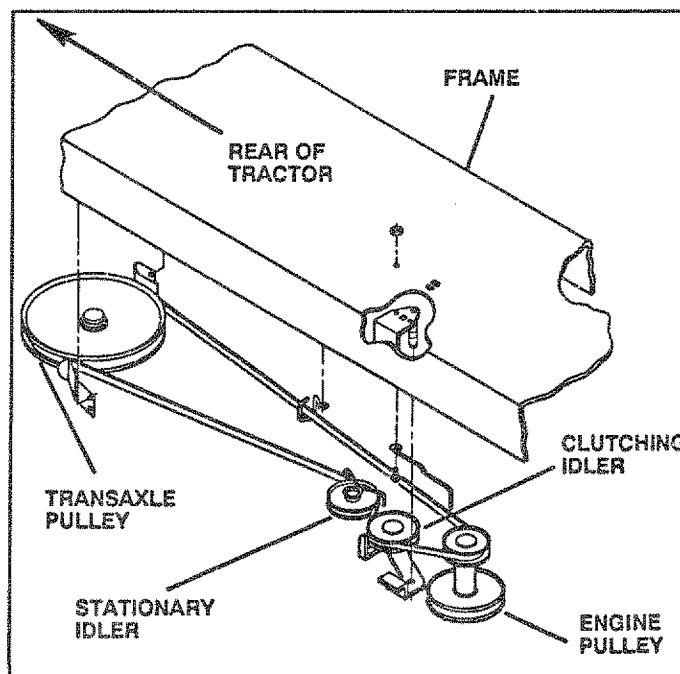

FIG. 24

# SERVICE AND ADJUSTMENTS

## TO ADJUST STEERING WHEEL ALIGNMENT

If steering wheel crossbars are not horizontal (left to right) when wheels are positioned straight forward, remove steering wheel and reassemble per instructions in the Assembly section of this manual.

## FRONT WHEEL TOE-IN/CAMBER

The front wheel toe-in and camber are not adjustable on your tractor. If damage has occurred to affect the front wheel toe-in or camber, contact your nearest authorized service center.

## TO REMOVE WHEEL FOR REPAIRS (See Fig. 25)

- Block up axle securely.
- Remove axle cover, retaining ring and washers to allow wheel removal (rear wheel contains a square key - Do not lose).
- Repair tire and reassemble.
- On rear wheels only: align grooves in rear wheel hub and axle. Insert square key.
- Replace washers and snap retaining ring securely in axle groove.
- Replace axle cover.

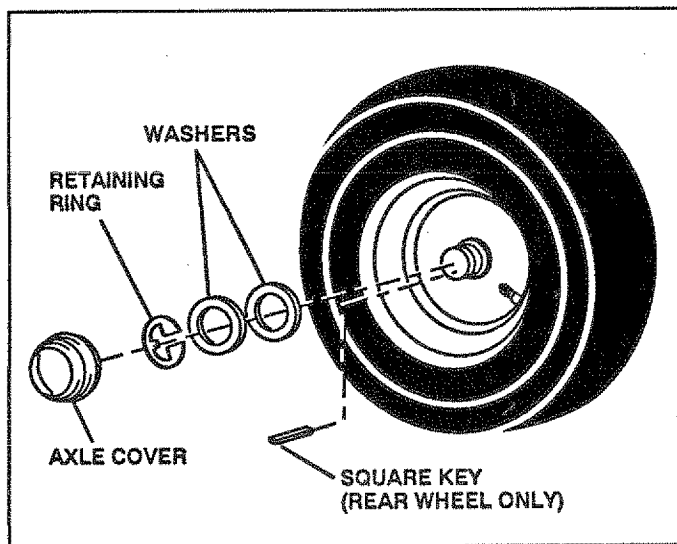

FIG. 25

## TO START ENGINE WITH A WEAK BATTERY (See Fig. 26)



**CAUTION:** Lead-acid batteries generate explosive gases. Keep sparks, flame and smoking materials away from batteries. Always wear eye protection when around batteries.

If your battery is too weak to start the engine, it should be recharged. If "jumper cables" are used for emergency starting, follow this procedure:

**IMPORTANT:** YOUR UNIT IS EQUIPPED WITH A 12 VOLT NEGATIVE GROUNDED SYSTEM. THE OTHER VEHICLE MUST ALSO BE A 12 VOLT NEGATIVE GROUNDED SYSTEM. DO NOT USE YOUR TRACTOR BATTERY TO START OTHER VEHICLES.

### TO ATTACH JUMPER CABLES -

- Connect each end of the RED cable to the POSITIVE (+) terminal of each battery, taking care not to short against chassis.
- Connect one end of the BLACK cable to the NEGATIVE (-) terminal of fully charged battery.
- Connect the other end of the BLACK cable to a good CHASSIS GROUND, away from fuel tank and battery.

### TO REMOVE CABLES, REVERSE ORDER -

- BLACK cable first from left side of chassis and fully charged battery.
- RED cable last from both batteries.

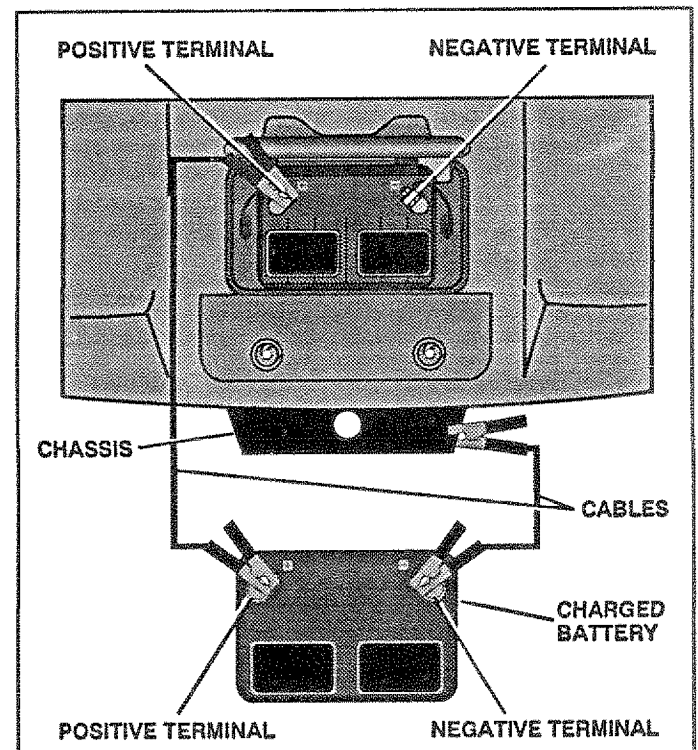

FIG. 26

# SERVICE AND ADJUSTMENTS

## TO REPLACE FUSE (See Fig. 27)

Replace with 30 amp automotive-type plug-in fuse. The fuse holder is located in the engine compartment, directly in front of the dash.

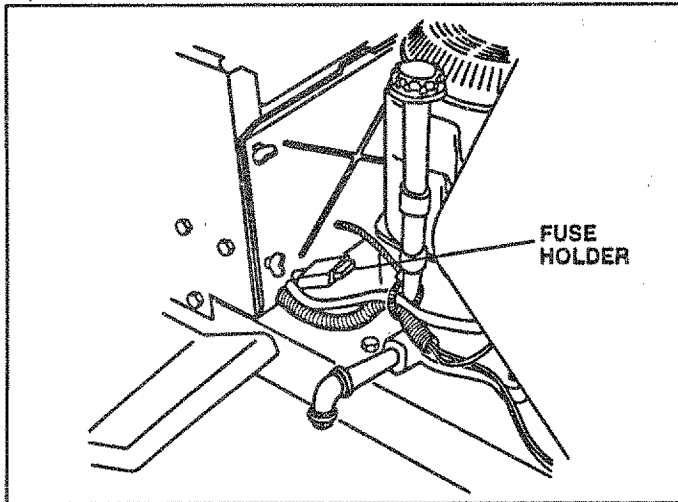

FIG. 27

## TO REPLACE HEADLIGHT BULB

- Raise hood.
- Pull bulb holder out of the hole in the backside of the grill.
- Replace bulb in holder and push bulb holder securely back into the hole in the backside of the grill.
- Close hood.

## INTERLOCKS AND RELAYS

Loose or damaged wiring may cause your tractor to run poorly, stop running or prevent it from starting.

- Check wiring. See electrical wiring diagram in Repair Parts section of this manual.

## TO REMOVE HOOD AND GRILL (See Fig. 28)



**CAUTION:** Muffler is hot. Be careful when removing retainer springs from hood pivot brackets.

- Raise hood.
- Unsnap headlight wire connector.
- Remove retainer springs from hood pivot brackets.
- Stand in front of tractor. Grasp hood at sides, tilt forward and lift off of tractor.
- To reinstall, slide hood pivot brackets into slots in frame. Replace retainer springs.
- Reconnect headlight wire connector and close hood.

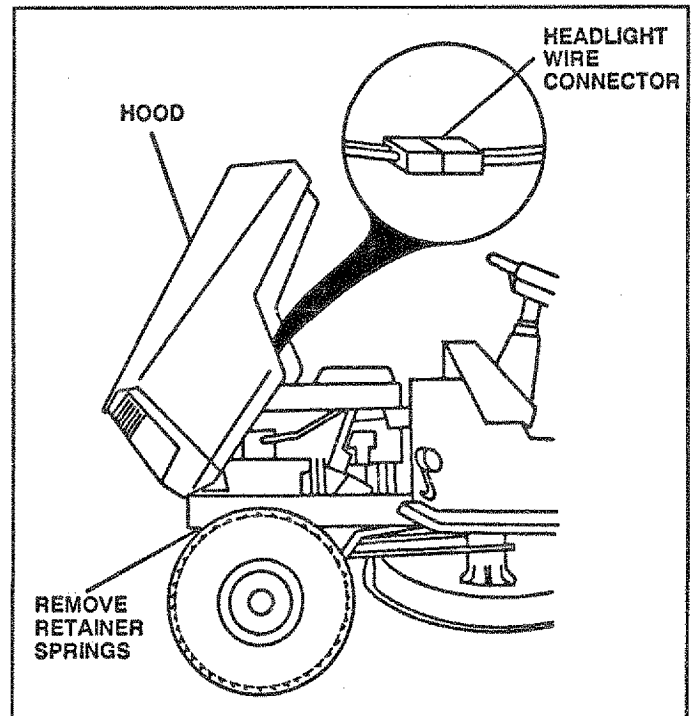

FIG. 28

# SERVICE AND ADJUSTMENTS

## ENGINE

### TO ADJUST THROTTLE CONTROL CABLE (See Fig. 29)

The throttle control has been preset at the factory and adjustment should not be necessary. Check adjustment as described below before loosening cable. If adjustment is necessary, proceed as follows:

- With engine not running, move throttle control lever from "SLOW" to "CHOKE" position. Slowly move lever from "CHOKE" to "FAST" position.
- Check that holes "A" in governor control lever and hole in governor plate line-up. If holes "A" are not aligned, loosen clamp screw and move throttle cable until holes are aligned. Tighten clamp screw securely.

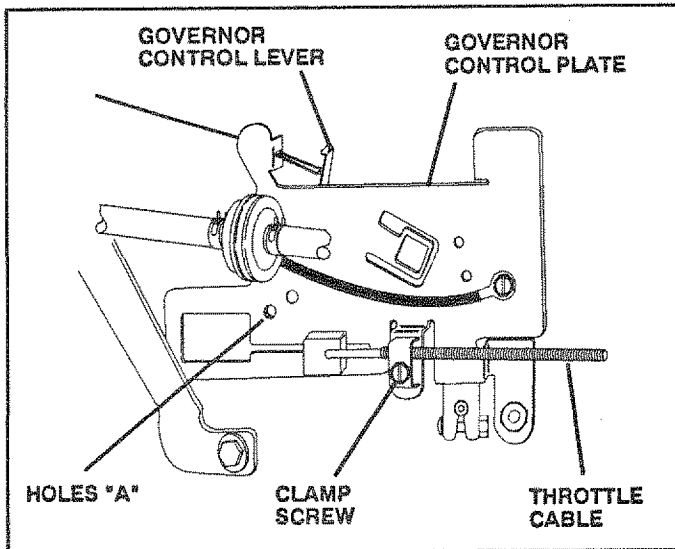

FIG. 29

### TO ADJUST CARBURETOR (See Fig. 30)

The carburetor has been preset at the factory and adjustment should not be necessary. However, minor adjustment may be required to compensate for differences in fuel, temperature, altitude or load. If the carburetor does need adjustment, proceed as follows:

In general, turning idle mixture valve in (clockwise) decreases the supply of fuel to the engine giving a leaner fuel/air mixture. Turning the idle mixture valve out (counterclockwise) increases the supply of fuel to the engine giving a richer fuel/air mixture.

**IMPORTANT: DAMAGE TO THE NEEDLE VALVE AND THE SEAT IN CARBURETOR MAY RESULT IF SCREW IS TURNED IN TOO TIGHT.**

#### PRELIMINARY SETTING -

- Air cleaner assembly must be assembled to the carburetor when making carburetor adjustments.
- Be sure the throttle control cable is adjusted properly (see above).
- With engine off turn idle mixture valve in (clockwise) closing it finger tight and then turn out (counterclockwise) 1 full turn.

#### FINAL SETTING -

- Start engine and allow to warm for five minutes. Make final adjustments with engine running and shift/motion control lever in "NEUTRAL" position.
- Move throttle control lever to "SLOW" position. With finger, rotate and hold throttle lever against idle speed screw. Turn idle speed screw to attain 1750 RPM.
- While still holding throttle lever against idle speed screw, turn idle mixture valve in (clockwise) until engine begins to die and then turn out (counterclockwise) until engine runs rough. Turn valve to a point midway between those two positions. Release throttle lever.

#### ACCELERATION TEST -

- Move throttle control lever from "SLOW" to "FAST" position. If engine hesitates or dies, turn idle mixture valve out (counterclockwise) 1/8 turn. Repeat test and continue to adjust, if necessary, until engine accelerates smoothly.

High speed stop is factory adjusted. Do not adjust - damage may result.

**IMPORTANT: NEVER TAMPER WITH THE ENGINE GOVERNOR, WHICH IS FACTORY SET FOR PROPER ENGINE SPEED. OVERSPEEDING THE ENGINE ABOVE THE FACTORY HIGH SPEED SETTING CAN BE DANGEROUS. IF YOU THINK THE ENGINE-GOVERNED HIGH SPEED NEEDS ADJUSTING, CONTACT YOUR NEAREST AUTHORIZED SERVICE CENTER, WHICH HAS PROPER EQUIPMENT AND EXPERIENCE TO MAKE ANY NECESSARY ADJUSTMENTS.**

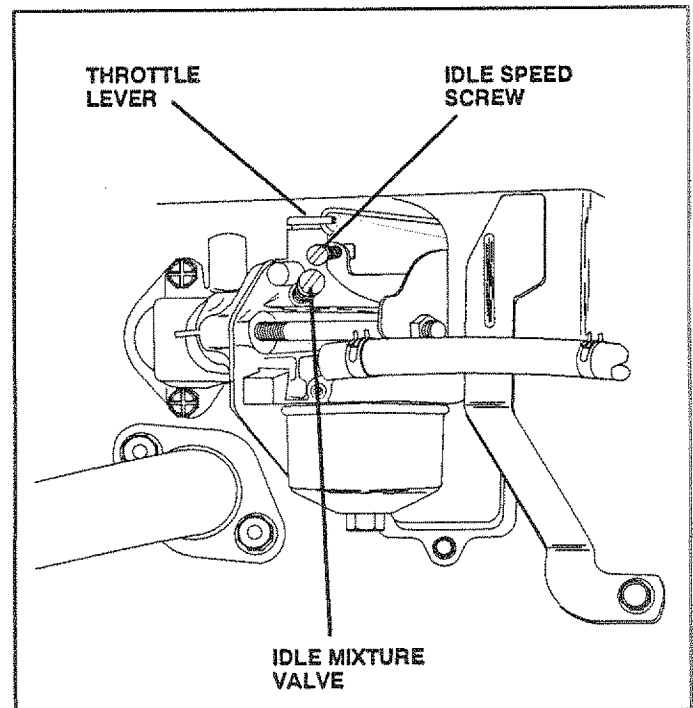

FIG. 30

# STORAGE

Immediately prepare your tractor for storage at the end of the season or if the unit will not be used for 30 days or more.



**CAUTION:** Never store the tractor with gasoline in the tank inside a building where fumes may reach an open flame or spark. Allow the engine to cool before storing in any enclosure.

## TRACTOR

Remove mower from tractor for winter storage. When mower is to be stored for a period of time, clean it thoroughly, remove all dirt, grease, leaves, etc. Store in a clean, dry area.

- Clean entire tractor (See "CLEANING" in the Customer Responsibilities section of this manual).
- Inspect and replace belts, if necessary (See belt replacement instructions in the Service and Adjustments section of this manual).
- Lubricate as shown in the Customer Responsibilities section of this manual.
- Be sure that all nuts, bolts and screws are securely fastened. Inspect moving parts for damage, breakage and wear. Replace if necessary.
- Touch up all rusted or chipped paint surfaces; sand lightly before painting.

## BATTERY

- Fully charge the battery for storage.
- After a period of time in storage, battery may require recharging.
- To help prevent corrosion and power leakage during long periods of storage, battery cables should be disconnected and battery cleaned thoroughly (see "TO CLEAN BATTERY AND TERMINALS" in the Customer Responsibilities section of this manual).
- After cleaning, leave cables disconnected and place cables where they cannot come in contact with battery terminals.
- Be sure battery drain tube is securely attached.

## ENGINE

### FUEL SYSTEM

**IMPORTANT:** IT IS IMPORTANT TO PREVENT GUM DEPOSITS FROM FORMING IN ESSENTIAL FUEL SYSTEM PARTS SUCH AS CARBURETOR, FUEL FILTER, FUEL HOSE, OR TANK DURING STORAGE. ALSO, EXPERIENCE INDICATES THAT ALCOHOL BLENDED FUELS (CALLED GASOHOL OR USING ETHANOL OR METHANOL) CAN ATTRACT MOISTURE WHICH LEADS TO SEPARATION AND FORMATION OF ACIDS DURING STORAGE. ACIDIC GAS CAN DAMAGE THE FUEL SYSTEM OF AN ENGINE WHILE IN STORAGE.

- Drain the fuel tank.
- Start the engine and let it run until the fuel lines and carburetor are empty.
- Never use engine or carburetor cleaner products in the fuel tank or permanent damage may occur.
- Use fresh fuel next season.

**NOTE:** Fuel stabilizer is an acceptable alternative in minimizing the formation of fuel gum deposits during storage. Add stabilizer to gasoline in fuel tank or storage container. Always follow the mix ratio found on stabilizer container. Run engine at least 10 minutes after adding stabilizer to allow the stabilizer to reach the carburetor. Do not drain the gas tank and carburetor if using fuel stabilizer.

### ENGINE OIL

Drain oil (with engine warm) and replace with clean engine oil. (See "ENGINE" in the Customer Responsibilities section of this manual).

### CYLINDERS

- Remove spark plug(s).
- Pour one ounce of oil through spark plug hole(s) into cylinder(s).
- Turn ignition key to "START" position for a few seconds to distribute oil.
- Replace with new spark plug(s).

### OTHER

- Do not store gasoline from one season to another.
- Replace your gasoline can if your can starts to rust. Rust and/or dirt in your gasoline will cause problems.
- If possible, store your unit indoors and cover it to give protection from dust and dirt.
- Cover your unit with a suitable protective cover that does not retain moisture. Do not use plastic. Plastic cannot breathe which allows condensation to form and will cause your unit to rust.

**IMPORTANT:** NEVER COVER TRACTOR WHILE ENGINE AND EXHAUST AREAS ARE STILL WARM.



# TROUBLESHOOTING POINTS

PROBLEM	CAUSE	CORRECTION
<b>Will not start</b>	<ol style="list-style-type: none"> <li>1. Out of fuel.</li> <li>2. Engine not "CHOKED" properly.</li> <li>3. Engine flooded.</li> <li>4. Bad spark plug.</li> <li>5. Dirty air filter.</li> <li>6. Dirty fuel filter.</li> <li>7. Water in fuel.</li>   <li>8. Loose or damaged wiring.</li> <li>9. Carburetor out of adjustment.</li> <li>10. Engine valves out of adjustment.</li> </ol>	<ol style="list-style-type: none"> <li>1. Fill fuel tank.</li> <li>2. See TO START ENGINE in Operation section.</li> <li>3. Wait several minutes before attempting to start.</li> <li>4. Replace spark plug.</li> <li>5. Clean/replace air filter.</li> <li>6. Replace fuel filter.</li> <li>7. Drain fuel tank and carburetor, refill tank with fresh gasoline and replace fuel filter.</li> <li>8. Check all wiring.</li> <li>9. Contact Sears Service Department.</li> <li>10. Contact Sears Service Department.</li> </ol>
<b>Hard to start</b>	<ol style="list-style-type: none"> <li>1. Dirty air filter.</li> <li>2. Bad spark plug.</li> <li>3. Weak or dead battery.</li> <li>4. Dirty fuel filter.</li> <li>5. Stale or dirty fuel.</li> <li>6. Loose or damaged wiring.</li> <li>7. Carburetor out of adjustment.</li> <li>8. Engine valves out of adjustment.</li> </ol>	<ol style="list-style-type: none"> <li>1. Clean/replace air filter.</li> <li>2. Replace spark plug.</li> <li>3. Recharge or replace battery.</li> <li>4. Replace fuel filter.</li> <li>5. Drain fuel tank and refill with fresh gasoline.</li> <li>6. Check all wiring.</li> <li>7. Contact Sears Service Department.</li> <li>8. Contact Sears Service Department.</li> </ol>
<b>Engine will not turn over</b>	<ol style="list-style-type: none"> <li>1. Clutch/brake pedal not depressed.</li> <li>2. Attachment clutch is engaged.</li> <li>3. Spark plug wire is disconnected.</li> <li>4. Weak or dead battery.</li> <li>5. Blown fuse.</li> <li>6. Corroded battery terminals.</li> <li>7. Loose or damaged wiring.</li> <li>8. Faulty ignition switch.</li> <li>9. Faulty solenoid or starter.</li> <li>10. Faulty operator presence switch(es).</li> </ol>	<ol style="list-style-type: none"> <li>1. Depress clutch/brake pedal.</li> <li>2. Disengage attachment clutch.</li> <li>3. Connect wire to spark plug.</li> <li>4. Recharge or replace battery.</li> <li>5. Replace fuse.</li> <li>6. Clean battery terminals.</li> <li>7. Check all wiring.</li> <li>8. Check/replace ignition switch.</li> <li>9. Check/replace solenoid or starter.</li> <li>10. Contact Sears Service Department.</li> </ol>
<b>Engine clicks but will not start</b>	<ol style="list-style-type: none"> <li>1. Weak or dead battery.</li> <li>2. Corroded battery terminals.</li> <li>3. Loose or damaged wiring.</li> <li>4. Faulty solenoid or starter.</li> </ol>	<ol style="list-style-type: none"> <li>1. Recharge or replace battery.</li> <li>2. Clean battery terminals.</li> <li>3. Check all wiring.</li> <li>4. Check/replace solenoid or starter.</li> </ol>
<b>Loss of power</b>	<ol style="list-style-type: none"> <li>1. Cutting too much grass/too fast.</li> <li>2. Throttle in "CHOKE" position.</li> <li>3. Build-up of grass, leaves and trash under mower.</li> <li>4. Dirty air filter.</li> <li>5. Low oil level/dirty oil.</li> <li>6. Faulty spark plug.</li> <li>7. Dirty fuel filter.</li> <li>8. Stale or dirty fuel.</li> <li>9. Water in fuel.</li>   <li>10. Spark plug wire loose.</li> <li>11. Dirty engine air screen/fins.</li> <li>12. Dirty/clogged muffler.</li> <li>13. Loose or damaged wiring.</li> <li>14. Carburetor out of adjustment.</li> <li>15. Engine valves out of adjustment.</li> </ol>	<ol style="list-style-type: none"> <li>1. Set in "Higher Cut" position/reduce speed.</li> <li>2. Adjust throttle control.</li> <li>3. Clean underside of mower housing.</li> <li>4. Clean/replace air filter.</li> <li>5. Check oil level/change oil.</li> <li>6. Clean and regap or change spark plug.</li> <li>7. Replace fuel filter.</li> <li>8. Drain fuel tank and refill with fresh gasoline.</li> <li>9. Drain fuel tank and carburetor, refill tank with fresh gasoline and replace fuel filter.</li> <li>10. Connect and tighten spark plug wire.</li> <li>11. Clean engine air screen/fins.</li> <li>12. Clean/replace muffler.</li> <li>13. Check all wiring.</li> <li>14. Contact Sears Service Department.</li> <li>15. Contact Sears Service Department.</li> </ol>
<b>Excessive vibration</b>	<ol style="list-style-type: none"> <li>1. Worn, bent or loose blade.</li> <li>2. Bent blade mandrel.</li> <li>3. Loose/damaged part(s).</li> </ol>	<ol style="list-style-type: none"> <li>1. Replace blade. Tighten blade bolt.</li> <li>2. Replace blade mandrel.</li> <li>3. Tighten loose part(s). Replace damaged parts.</li> </ol>

# TROUBLESHOOTING POINTS

PROBLEM	CAUSE	CORRECTION
Engine continues to run when operator leaves seat with attachment clutch engaged	<ol style="list-style-type: none"> <li>1. Faulty operator-safety presence control system.</li> </ol>	<ol style="list-style-type: none"> <li>1. Check wiring, switches and connections. If not corrected, contact Sears Service Department.</li> </ol>
Poor cut - uneven	<ol style="list-style-type: none"> <li>1. Worn, bent or loose blade.</li> <li>2. Mower deck not level.</li> <li>3. Buildup of grass, leaves, and trash under mower.</li> <li>4. Bent blade mandrel.</li> </ol>	<ol style="list-style-type: none"> <li>1. Replace blade. Tighten blade bolt.</li> <li>2. Level mower deck.</li> <li>3. Clean underside of mower housing.</li> <li>4. Replace blade mandrel.</li> </ol>
Mower blades will not rotate	<ol style="list-style-type: none"> <li>1. Obstruction in clutch mechanism.</li> <li>2. Worn/damaged mower drive belt.</li> <li>3. Frozen idler pulley.</li> <li>4. Frozen blade mandrel.</li> </ol>	<ol style="list-style-type: none"> <li>1. Remove obstruction.</li> <li>2. Replace mower drive belt.</li> <li>3. Replace idler pulley.</li> <li>4. Replace blade mandrel.</li> </ol>
Poor grass discharge	<ol style="list-style-type: none"> <li>1. Engine speed too slow.</li> <li>2. Travel speed too fast.</li> <li>3. Wet grass.</li> <li>4. Mower deck not level.</li> <li>5. Low/uneven tire air pressure.</li> <li>6. Worn, bent or loose blade.</li> <li>7. Buildup of grass, leaves and trash under mower.</li> <li>8. Mower drive belt worn.</li> <li>9. Blades improperly installed.</li> <li>10. Improper blades used.</li> </ol>	<ol style="list-style-type: none"> <li>1. Place throttle control in "FAST" position.</li> <li>2. Shift to slower speed.</li> <li>3. Allow grass to dry before mowing.</li> <li>4. Level mower deck.</li> <li>5. Check tires for proper air pressure.</li> <li>6. Replace/sharpen blade. Tighten blade bolt.</li> <li>7. Clean underside of mower housing.</li> <li>8. Replace mower drive belt.</li> <li>9. Reinstall blades sharp edge down.</li> <li>10. Replace with blades listed in this manual.</li> </ol>
Headlight(s) not working (if so equipped)	<ol style="list-style-type: none"> <li>1. Switch is "OFF".</li> <li>2. Bulb(s) burned out.</li> <li>3. Faulty light switch.</li> <li>4. Loose or damaged wiring.</li> <li>5. Blown fuse.</li> </ol>	<ol style="list-style-type: none"> <li>1. Turn switch "ON".</li> <li>2. Replace bulb(s).</li> <li>3. Check/replace light switch.</li> <li>4. Check wiring and connections.</li> <li>5. Replace fuse.</li> </ol>
Battery will not charge	<ol style="list-style-type: none"> <li>1. Bad battery cell(s).</li> <li>2. Poor cable connections.</li> <li>3. Faulty regulator (if so equipped).</li> <li>4. Faulty alternator.</li> </ol>	<ol style="list-style-type: none"> <li>1. Replace battery.</li> <li>2. Check/clean all connections.</li> <li>3. Replace regulator.</li> <li>4. Replace alternator.</li> </ol>

# 12 HP 38" RIDING LAWN TRACTOR -- MODEL NUMBER 917.255560 SCHEMATIC

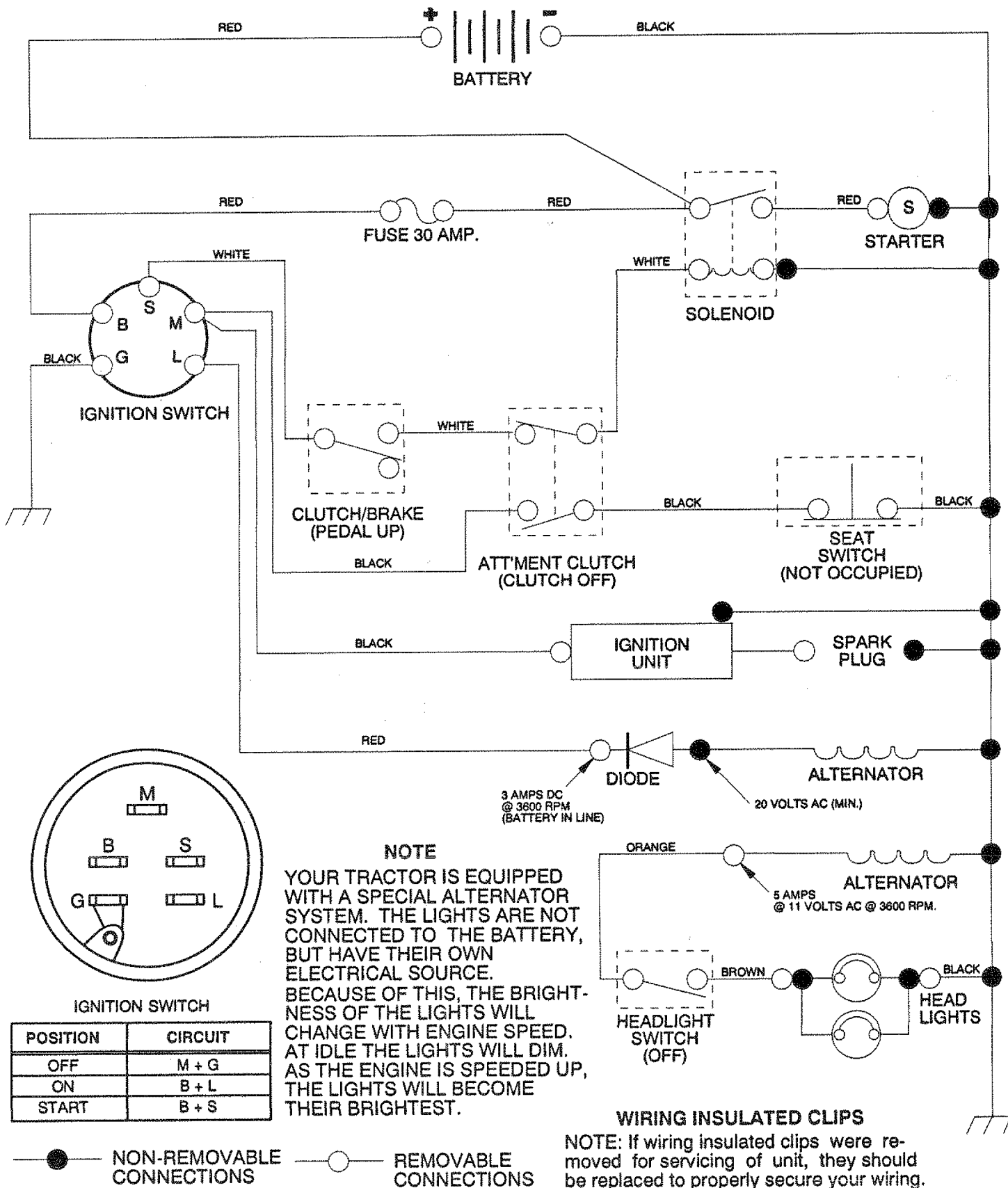

# REPAIR PARTS

12 HP 38" RIDING LAWN TRACTOR - - MODEL NUMBER 917.255560

## ELECTRICAL

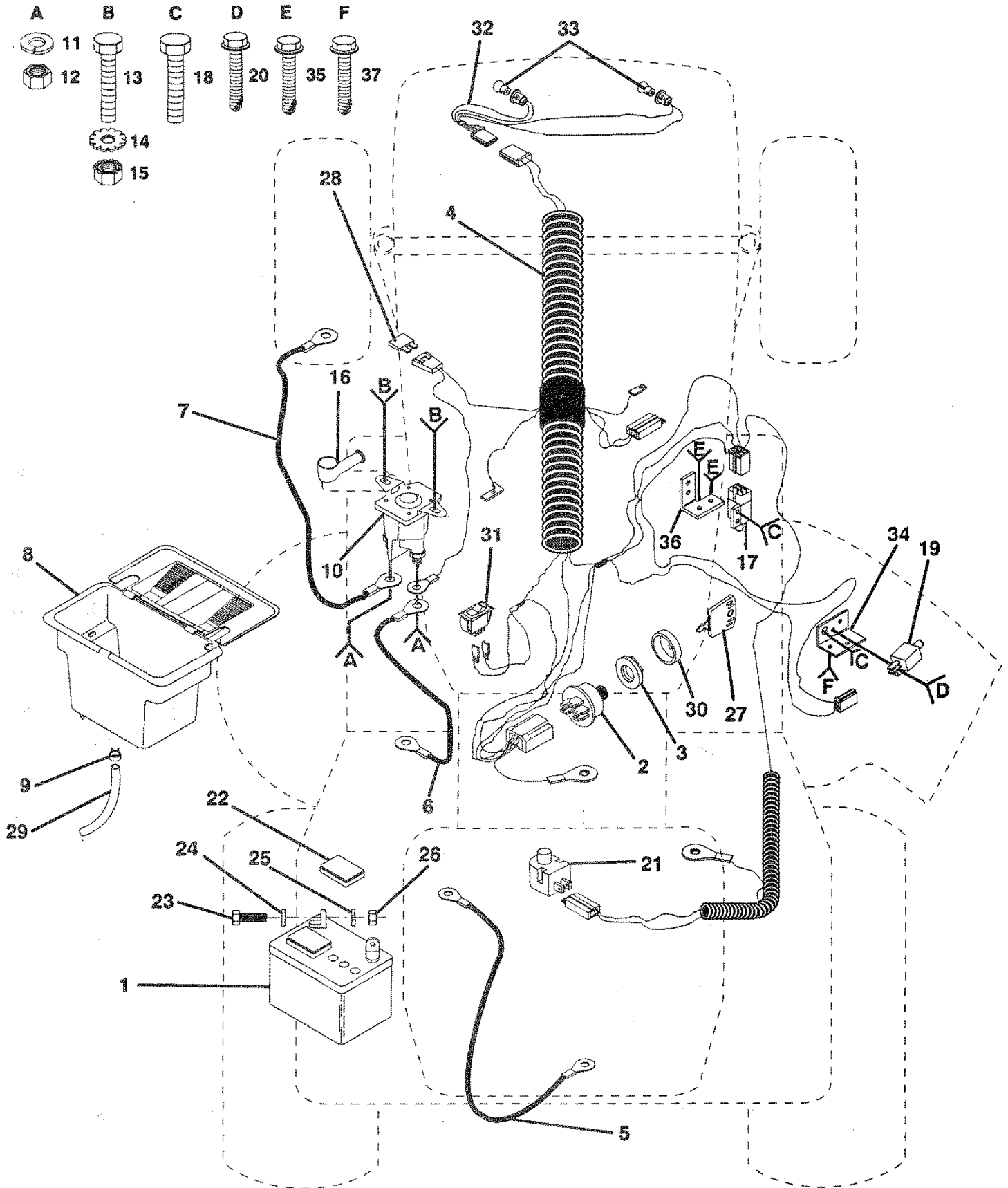

# REPAIR PARTS

12 HP 38" RIDING LAWN TRACTOR - - MODEL NUMBER 917.255560

## ELECTRICAL

KEY PART NO. NO.	DESCRIPTION
1 121265X	Battery 12 Volt 25 Amp
2 STD365402	* Switch Ign 5 Term Wo/wash/nut
3 124211X	Nut Ignition
4 132017	Harness Ign Bs Dash Headlights
5 4207J	Cable Ground 6ga 12"black
6 132202	Cable Battery 6 Ga 42"red
7 4799J	Cable Battery 6ga 11"red
8 129965	Case Battery Hinge Mechanical
9 109596X	Clamp Hose Olive
10 109081X	Solenoid
11 STD551125	* Washer Lock 1/4
12 73350400	Nut Jam Hex 1/4-20 Unc
13 74780408	Bolt Fin Hex 1/4-20uncx1/2 Gr5
14 STD551225	* Washer Lock Ext Tooth 1/4
15 STD541425	* Nut Keps Hex 1/4-20 Unc
16 131563	Cover Terminal Red
17 109553X	Switch Intlk Clutch Red 4 Term
18 STD601005	* Screw Tap Hex #10-24unc X 1/2
19 104445X	Switch Intlk Clutch Red 2 Term
20 STD601005	* Screw Tap Hex #10-24unc X 1/2
21 121305X	Switch Plunger Nc Gray
22 121264X	Caps Battery 25/30 Amp
23 74760412	Bolt Hex Hd 1/4-20unc X 3/4
24 STD551025	* Washer 9/32 X 5/8 X 16 Ga
25 STD551125	* Washer Lock Hvy Helical 1/4
26 STD541025	* Nut Fin Hex 1/4-20 Unc
27 109310X	Key Ign Molded Craftsman
28 108824X	Fuse 30 Amp Auto Green
29 105687X	Tube Plastic 9"
30 123620X	Cover Sw Key Blk 1 25 Text Sit
31 110712X	Switch Light Blk Blk Red
32 127441X	Harness Socket Light
33 7662J	Bulb Light #1141
34 108236X	Bracket Switch Clutch
35 STD601005	* Screw Tap Hex #10-24unc X 1/2
36 130890	Bracket Switch Interlock
37 STD601005	* Screw Tap Hex #10-24unc X 1/2

\* STANDARD HARDWARE - - PURCHASE LOCALLY  
NOTE: All component dimensions given in U.S. inches  
1 inch = 25.4 mm

# REPAIR PARTS

12 HP 38" RIDING LAWN TRACTOR - - MODEL NUMBER 917.255560  
CHASSIS AND ENCLOSURES

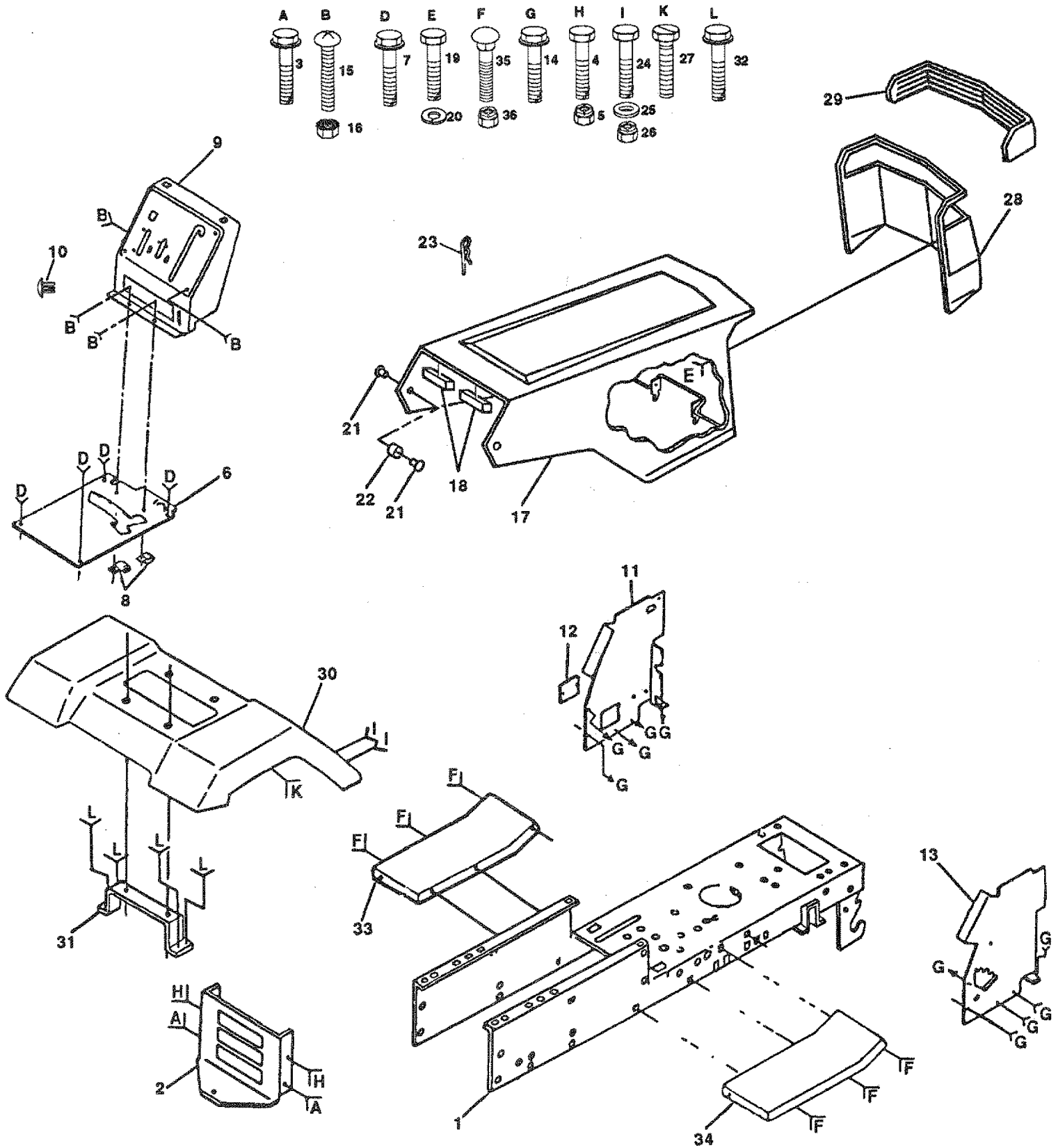

# REPAIR PARTS

12 HP 38" RIDING LAWN TRACTOR - - MODEL NUMBER 917.255560

## CHASSIS AND ENCLOSURES

KEY PART NO.	NO.	DESCRIPTION
1	131052	Chassis Weldment 12ga 38/42
2	127866	Drawbar Lt/yt 11 Ga
3	17490612	Screw Thdrol 3/8-16x3/4 Ty-tt
4	STD523707	* Bolt Fin Hex 3/8-16unc X 3/4
5	STD541437	* Nut Crownlock 3/8-16 Unc
6	124465x014	Saddle Silkscreen 5sp English
7	17490608	Screw Thdrol 3/8-16x1/2 Ty-tt
8	2751R	Clip Line Fuel 13/32 Mtg Hole
9	123042X	Dash Silkscreened Sears Eng
10	5479J	Plug Button Blk 359 Dia
11	122795X	Panel Pnt Dash Lh
12	121794X	Cover Access Black Square
13	124031X	Panel Silkscr Dash Rh Weldment
14	17490608	Screw Thdrol 3/8-16x1/2 Ty-tt
15	74180512	Screw Mach Trhd 5/16-18uncx3/4
16	STD541431	* Nut Keps 5/16-18 Unc
17	131445x417	Hood Asm Pnt Weld Silver Powde
18	126938X	Bumper Hood
19	STD512505	* Bolt Fin Hex 1/4-20unc X 1/2
20	STD551125	* Washer Lock Hvy Helical 1/4
21	122933X	Rivet Ratchet Nylon
22	124479X	Washer Nylon Blk 28x 75x 19
23	4921H	Retainer Spring
24	STD523707	* Bolt Fin Hex 3/8-16unc X 3/4
25	19131312	Washer 13/32 X 13/16 X 12 Ga
26	STD541437	* Nut Crownlock 3/8-16 Unc
27	17490608	Screw Thdrol 3/8-16x1/2 Ty-tt
28	123915X	Grille Grey
29	124029X	Lens Headlight Bar Clear
30	109872x417	Fender Pnt
31	109873X	Bracket Pnt Fender
32	17490612	Screw Thdrol 3/8-16x3/4 Ty-tt
33	105476x417	Footrest Pnt Lh Perf (silver)
34	105475x417	Footrest Pnt Rh Perf (silver)
35	STD533707	* Bolt Rdhd Sht Sqnk 3/8-16 X3/4
36	STD541437	* Nut Crownlock 3/8-16 Unc

\* STANDARD HARDWARE - - PURCHASE LOCALLY  
NOTE: All component dimensions given in U.S. inches  
1 inch = 25.4 mm

# REPAIR PARTS

12 HP 38" RIDING LAWN TRACTOR -- MODEL NUMBER 917.255560

DRIVE

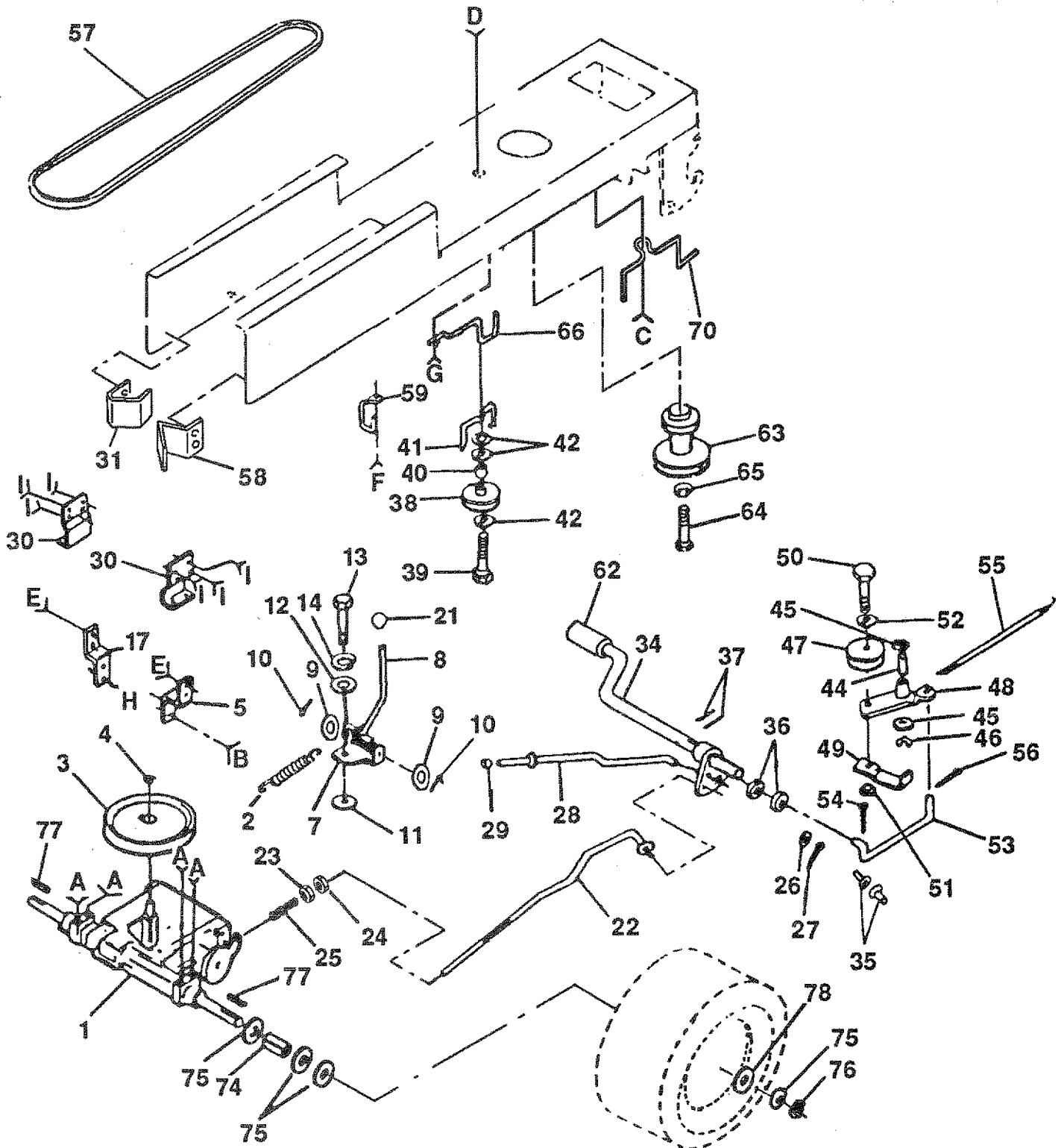

- |          |          |          |          |          |          |          |          |          |
|----------|----------|----------|----------|----------|----------|----------|----------|----------|
| <b>A</b> | <b>B</b> | <b>C</b> | <b>D</b> | <b>E</b> | <b>F</b> | <b>G</b> | <b>H</b> | <b>I</b> |
|          |          |          |          |          |          |          |          |          |
| 15       | 6        | 71       | 43       | 18       | 61       | 67       | 20       | 32       |
|          |          |          |          |          |          |          |          |          |
| 16       |          | 72       |          | 19       | 60       | 68       |          | 33       |
|          |          |          |          |          |          |          |          |          |
|          |          | 73       |          |          |          | 69       |          |          |



# REPAIR PARTS

12 HP 38" RIDING LAWN TRACTOR - - MODEL NUMBER 917.255560

## DRIVE

KEY PART NO. NO.	DESCRIPTION	KEY PART NO. NO.	DESCRIPTION
1	120897X Transaxle 5sp Std Dana	42	19131312 Washer 13/32 X 13/16 X 12 Ga
2	110422X Spring Return Brake T/a Zinc	43	STD541437 *Nut Crownlock 3/8-16 Unc
3	123666X Pulley Transaxle Alum	44	105706X Bearing Nyl 503 X 628 X 1 25
4	12000028 Ring Retainer # 5100-62	45	110812X Washer Hardened
5	121520X Strap Pnt Torque 30 Deg Blk	46	12000039 Ring Klip #15304-50
6	17490512 Screw Thdrol 5/16-18 X 3/4 Tyt	47	127783 Pulley Idler V Groove Plastic
7	106919X Plate Pnt Rod Shift T/a (blk )	48	123789X Bellcrank Asm
8	124461X Rod Shifter Blk (dana)	49	123205X Retainer Belt Style Spring
9	19151216 Washer 15/32 X 3/4 X 16ga	50	STD523715 *Bolt Hex Hd 3/8-16unc X 1-1/2
10	STD561210 *Pin Cotter 1/8 X 1 Cad	51	STD541437 *Nut Crownlock 3/8-16 Unc
11	105701X Washer Plate Shf 388 Sq Hole	52	STD551037 *Washer 13/32 X 13/16 X 16 Ga
12	19091210 Washer 9/32 X 3/4 X 10 Ga	53	105710X Link Clutch 7 66
13	71040412 Bolt Fin Hex 1/4-28unfx3/4 Gr8	54	STD561210 *Pin Cotter 1/8 X 3/4 Cad
14	STD551125 *Washer Lock Hvy Helical 1/4	55	105709X Spring Return Clutch 6 75
15	STD523727 *Bolt Fin Hex 3/8-16unc X 2-3/4	56	STD561210 *Pin Cotter 1/8 X 3/4 Cad
16	STD541437 *Nut Crownlock 3/8-16 Unc	57	125907X V-belt Ground Drive 90 00
17	121520X Strap Pnt Torque 30 Deg Blk	58	127274X Keeper Belt Rh Lt Pnt/zinc 16g
18	STD523707 *Bolt Fin Hex 3/8-16unc X 3/4	59	104777X Retainer Belt Chassis Lh Zinc
19	STD541437 *Nut Crownlock 3/8-16 Unc	60	19131312 Washer 13/32 X 13/16 X 12 Ga
20	17490512 Screw Thdrol 5/16-18 X 3/4 Tyt	61	17490612 Screw Thdrol 3/8-16x3/4 Ty-tt
21	106933X Knob Rd 1/2-13 Pstc Thds Blk	62	8883R Cover Pedal Blk Std
22	131867 Rod Brake Lt	63	131002 Pulley Engine
23	STD541437 *Nut Lock Hex W/wsh 3/8-16unc	64	71130720 Bolt Finhex 7/16-20unfx1-1/4g8
24	STD541237 *Nut Hex Jam 3/8-16 Unc	65	STD551143 *Washer Lock Hvy Hlcl Spr 7/16
25	106888X Spring Rod Brake 2 00 Zinc	66	129921 Keeper Belt Engine Lh Lt
26	STD551037 *Washer 13/32 X 13/16 X 16 Ga	67	STD523710 *Bolt Fin Hex 3/8-16unc X 1
27	STD561210 *Pin Cotter 1/8 X 3/4 Cad	68	19131312 Washer 13/32 X 13/16 X 12 Ga
28	128904 Rod Brake Parking Lt	69	STD541437 *Nut Crownlock 3/8-16 Unc
29	124236X Cap Parking Brake Red	70	131402 Guide Belt Dr Mower Rh
30	109167X Bracket Transmission	71	STD523710 *Bolt Fin Hex 3/8-16unc X 1
31	127275X Keeper Belt Lh Lt 14 Ga	72	19132012 Washer 13/32 X 1-1/4 X 12 Ga
32	STD523707 *Bolt Fin Hex 3/8-16unc X 3/4	73	STD541437 *Nut Crownlock 3/8-16 Unc
33	STD541437 *Nut Crownlock 3/8-16 Unc	74	109502X Spacer Split 80x1 94 Cad/zinc
34	122424X Shaft Asm Pedal Foot 1 930	75	121749X Washer 25/32 X 1 1/4 X 16 Ga
35	120183X Bearing Nylon Blk 629 Id	76	STD581075 *Ring E #5133-75
36	STD551062 *Washer 21/32 X 1 X 16 Ga	77	123583X Key Square 2 0 X 1845/ 1865
37	STD571810 *Pin Roll 3/16 X 1"	78	121748X Washer 25/32 X 1 5/8 X 16ga
38	123674X Pulley Idler Flat		
39	STD523727 *Bolt Fin Hex 3/8-16unc X 2-3/4		
40	4470J Spacer Split 395 X 59 Bzp		
41	109070X Keeper Belt Retainer		

\* STANDARD HARDWARE - - PURCHASE LOCALLY  
 NOTE: All component dimensions given in U.S. inches  
 1 inch = 25.4 mm

# REPAIR PARTS

12 HP 38" RIDING LAWN TRACTOR - - MODEL NUMBER 917.255560  
STEERING ASSEMBLY

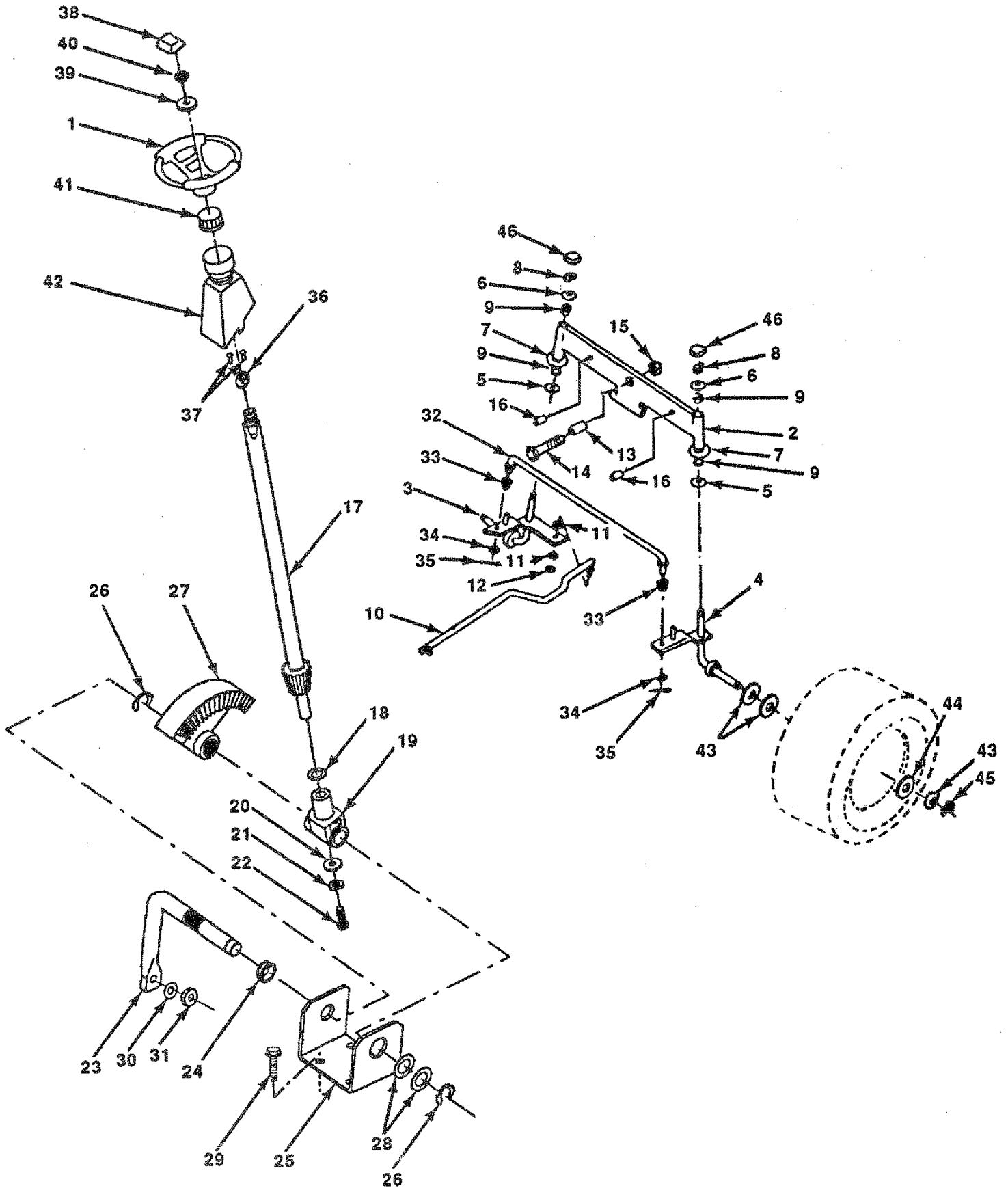

# REPAIR PARTS

12 HP 38" RIDING LAWN TRACTOR - - MODEL NUMBER 917.255560

## STEERING ASSEMBLY

KEY PART NO.	PART NO.	DESCRIPTION
	1	100713N Wheel Steering Std Black
	2	105669X Axle Asm Front
	3	130460 Spindle Asm Lh
	4	130459 Spindle Asm Rh
	5	6266H Bearing Race Thrust Harden
	6	121748X Washer 25/32 X 1 5/8 X 16ga
	7	19272016 Washer 27/32 X 1 1/4 X 16 Ga
	8	12000029 Ring Klip #t5304-75
	9	3366R Bearing Col Strg Blk
	10	130468 Link Drag Sol Ball Jt 20 064
	11	STD551137 *Washer Lock Hvy Hlcl Spr 3/8
	12	73610600 Nut Fin Hex 3/8-24 Unf
	13	110438X Spacer Bearing Axle Front
	14	74011056 Bolt Hex 5/8-11 Unc X 3-1/2
	15	73601000 Nut Hex Jam Lk W/wh 5/8-11 Unc
	16	132624 Pin Axle 5/8 X 1 55/1 54 Lg
	17	132614 Shaft Asm Strg 5/8 X 15 19 Lt
	18	57079 Washer Thrust 515x 750x 033
	19	124035X Support Shaft
	20	126684X Washer Shim 1/4 X 5/8 X 062
	21	STD551125 *Washer Lock Hvy Helical 1/4
	22	71070410 Screw Hex Socket 1/4-20 X 5/8
	23	127501 Shaft Asm Pittman
	24	109816X Nyliner Snap In
	25	124036X Bracket Steering
	26	12000029 Ring Klip #t5304-75
	27	124034X Gear Sector
	28	6266H Bearing Race Thrust Harden
	29	17490612 Screw Thdrol 3/8-16x3/4 Ty-tt
	30	STD551137 *Washer Lock Hvy Hlcl Spr 3/8
	31	73610600 Nut Fin Hex 3/8-24 Unf
	32	130465 Rod Tie Wire Form 19 75 Mech
	33	120754X Bushing Rod Tie Blk Lt
	34	19131416 Washer 13/32 X 7/8 X 16ga
	35	STD561210 *Pin Cotter 1/8 X 3/4 Cad
	36	132196 Bushing Strg 5/8 Id Dash
	37	STD611005 *Screw Slftp #10-16 X 1/2 Ty-b
	38	100710L Insert Cap Strg Wheel Std Blk
	39	19133808 Washer 13/32 X 2-3/8 X 8 Ga
	40	STD541537 *Nut Lock Center 3/8-24unf
	41	104820X Adaptor Wheel Strg 640/ 635id
	42	124417X Boot Shaft Steering
	43	121749X Washer 25/32 X 1 1/4 X 16 Ga
	44	121748X Washer 25/32 X 1 5/8 X 16ga
	45	12000029 Ring Klip #t5304-75
	46	121232X Cap Spindle Fr Top Blk

\* STANDARD HARDWARE - - PURCHASE LOCALLY  
NOTE: All component dimensions given in U.S. inches  
1 inch = 25.4 mm

# REPAIR PARTS

## 12 HP 38" RIDING LAWN TRACTOR -- MODEL NUMBER 917.255560 SEAT ASSEMBLY

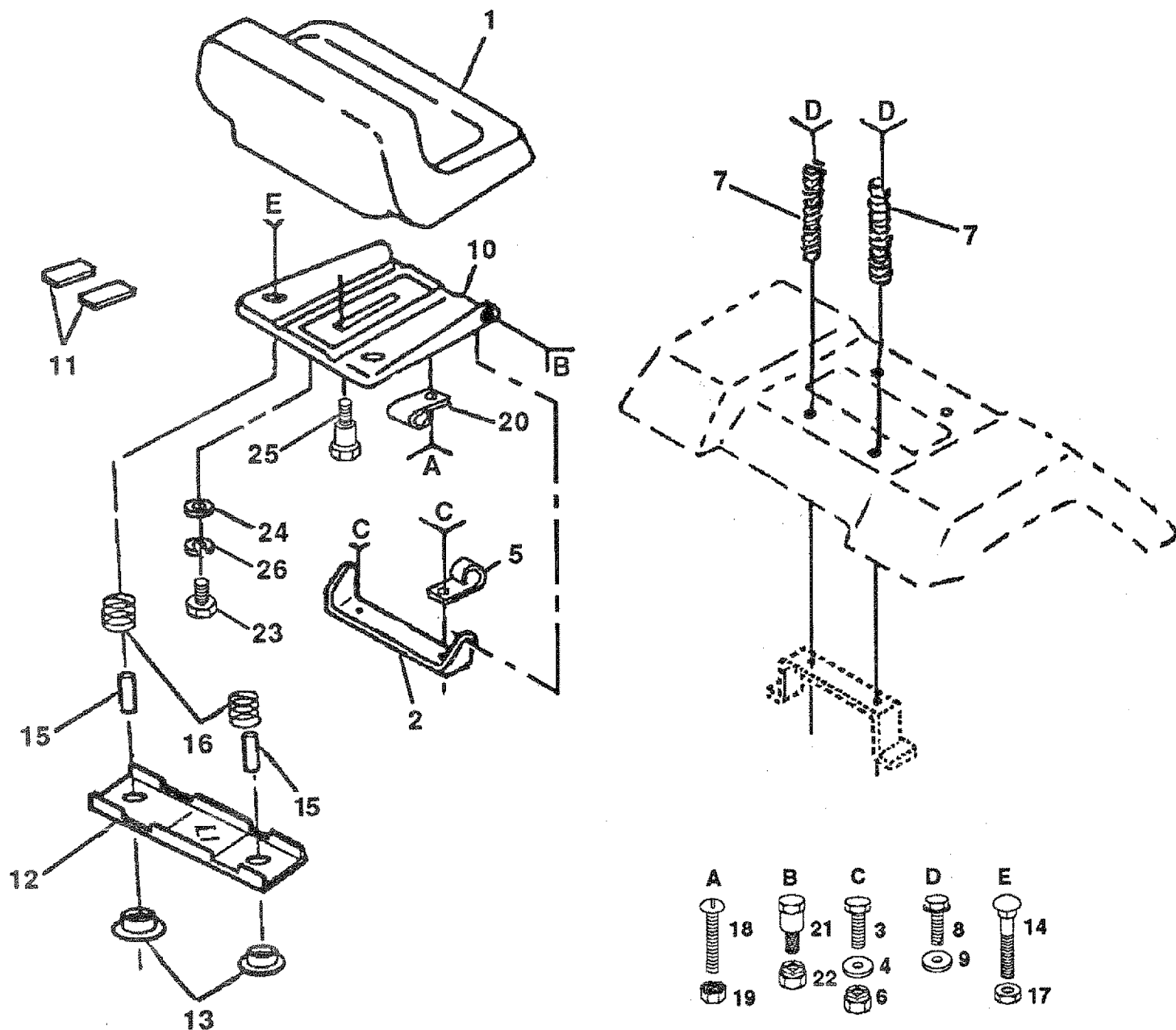

KEY PART NO. NO.	DESCRIPTION
1	127436 Seat V250 Blk/red Craftsman
2	126656X Bracket Pnt Pivot Seat (blk)
3	STD523707 * Bolt Fin Hex 3/8-16unc X 3/4
4	19131210 Washer 13/32 X 3/4 X 10 Ga
5	2751R Clip Line Fuel 13/32 Mtg Hole
6	STD541437 * Nut Crownlock 3/8-16 Unc
7	124181X Spring Seat Cprsn 2 250 Blk Zi
8	17490616 Screw Thdrol 3/8-16 X 1 Ty-tt
9	19131614 Washer 13/32 X 1 X 14 Ga
10	124294X Pan Pnt Seat (blk)
11	121251X Strip Foam Gray Or Black
12	121246X Bracket Pnt Mounting Switch
13	121248X Bushing Snap Blk Nyi 50 Id
14	72050411 Bolt Rdhd Sht Nk 1/4-20x1-3/8
15	121249X Spacer Split 28 X 88 Zinc

KEY PART NO. NO.	DESCRIPTION
16	121250X Spring Cprsn 1 27 Blk Pnt
17	123976X Nut Lock 1/4 Lge Flg Gr 5 Zinc
18	STD511005 * Screw Sltd Pan Hd #10-32 X 1/2
19	73951000 Nut Keps #10-32 Unf
20	4171R Clip Insulated 11/32 Mtg Hole
21	105529X Bolt Shoulder 5/16-18 Unc Blkz
22	STD541431 * Nut Crown Lock 5/16-18
23	74780814 Bolt Fin Hex 1/2-13 X 7/8 Gr 5
24	19171912 Washer 17/32 X 1-3/16 X 12 Ga
25	127018X Bolt Shoulder 5/16-18 X 62
26	STD551150 * Washer Lock Hvy Hlcl Spr 1/2

\* STANDARD HARDWARE -- PURCHASE LOCALLY  
NOTE: All component dimensions given in U.S. inches  
1 inch = 25.4 mm

# REPAIR PARTS

12 HP 38" RIDING LAWN TRACTOR - - MODEL NUMBER 917.255560

## DECALS

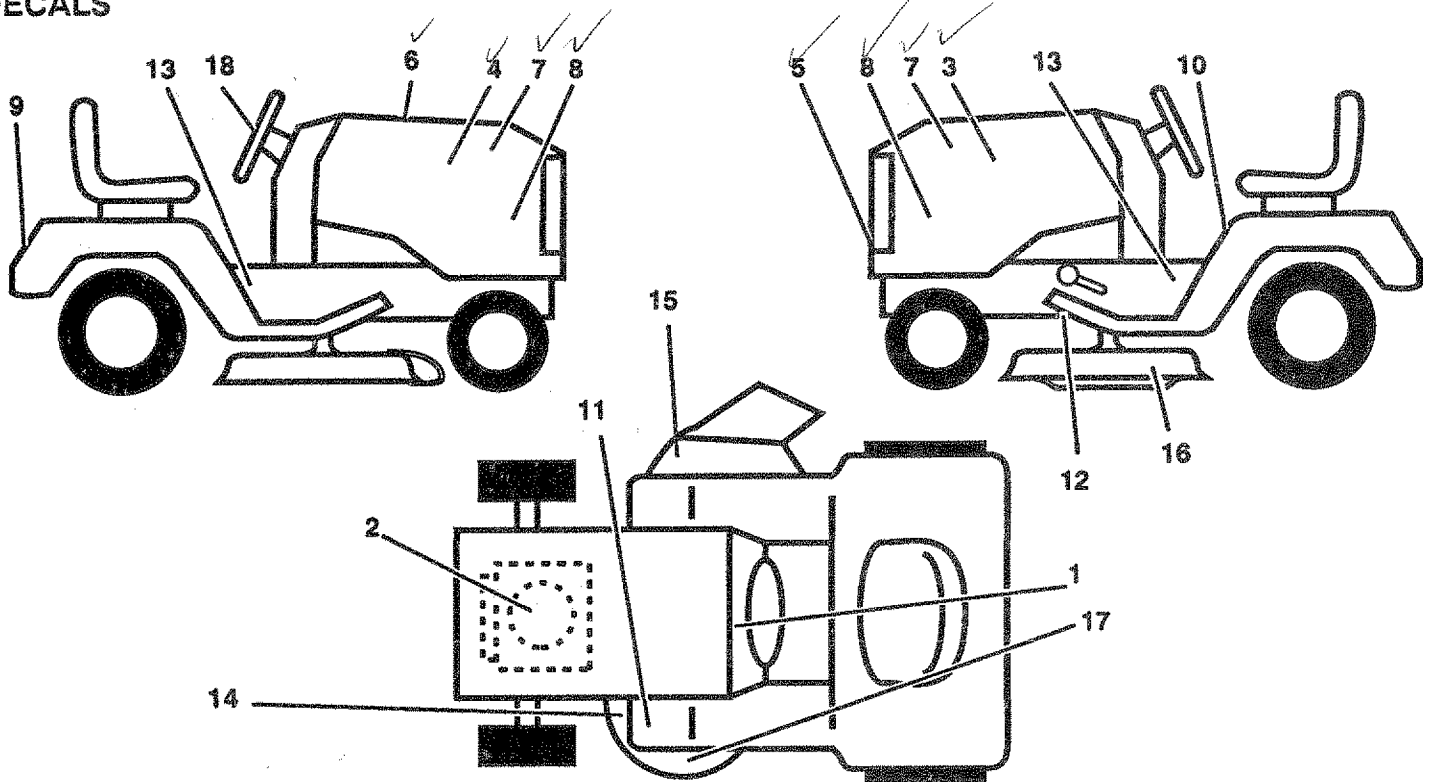

### KEY PART NO. NO.

### DESCRIPTION

1	108456X	Decal Instruction Operat Eng
2	126685X	Decal Eng 12hp lc B&s Craft
3	124489X	Decal Hood Slope Rh Craftsman
4	124490X	Decal Hood Slope Lh Craftsman
5	132674	Decal Grille Lt4000 Craft Usa
6	133644	Decal Maint Customer Sears Dom
7	126770X	Decal Panel Side12 Hp lc
8	108631X	Decal li(die Cut)
9	125880X	Decal Fender Craftsman Red
10	106974X	Decal Caution English

### KEY PART NO. NO.

### DESCRIPTION

11	4900J	Decal Clutch/brake English
12	109199X	Decal V-belt Dr Sch Tractor E
13	105809X	Decal Chassis 5 Sp 38"
14	130929	Decal Mower Drive Schematic 38
15	121343X	Decal Danger English
16	3713J	Decal Rota Blades English
17	133179	Decal Mower Qc System
18	132267	Decal Insr Wh Strg Crafts Usa
--	133089	Manual Owners 255560

## WHEELS & TIRES

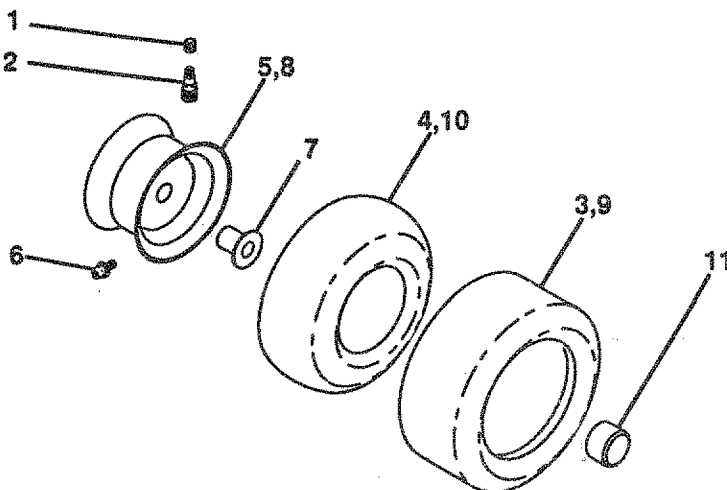

### KEY PART NO. NO.

### DESCRIPTION

1	59192	Cap Value Tire
2	65139	Stem Value
3	124157X	Tire Front Turf 11(Optional, Service Item Only)
4	59904	Tube Inner Front #35060
5	106732x361	Rim Asm 6"front Silver Service
6	278H	Fitting Grease
7	9040H	Bearing Flange
8	106108x361	Rim Asm 8"rear Silver Service
9	123969X	Tire R Tsii 18x8 5-8 C Service
10	7152J	Tube Rear 9 5 X 8 Service (Optional, Service Item Only)
11	104757X	Cap Axle Blk 1 50 X 1 00

NOTE: All component dimensions given in U.S. inches  
1 inch = 25.4 mm

# REPAIR PARTS

12 HP 38" RIDING LAWN TRACTOR -- MODEL NUMBER 917.255560

## ENGINE

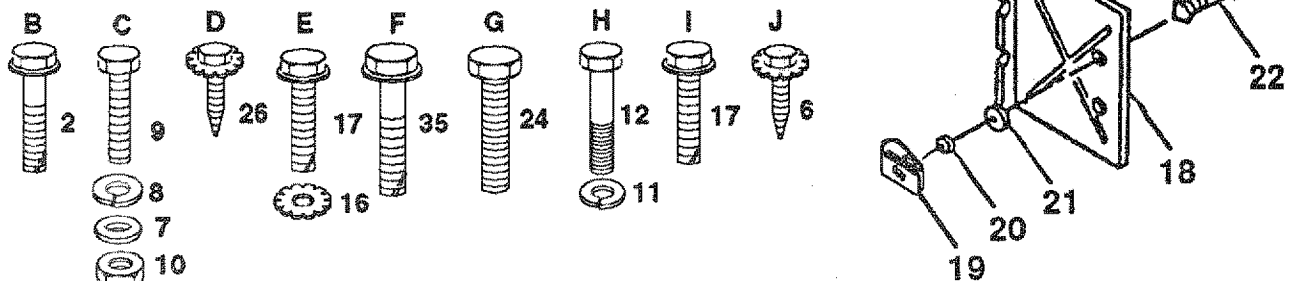
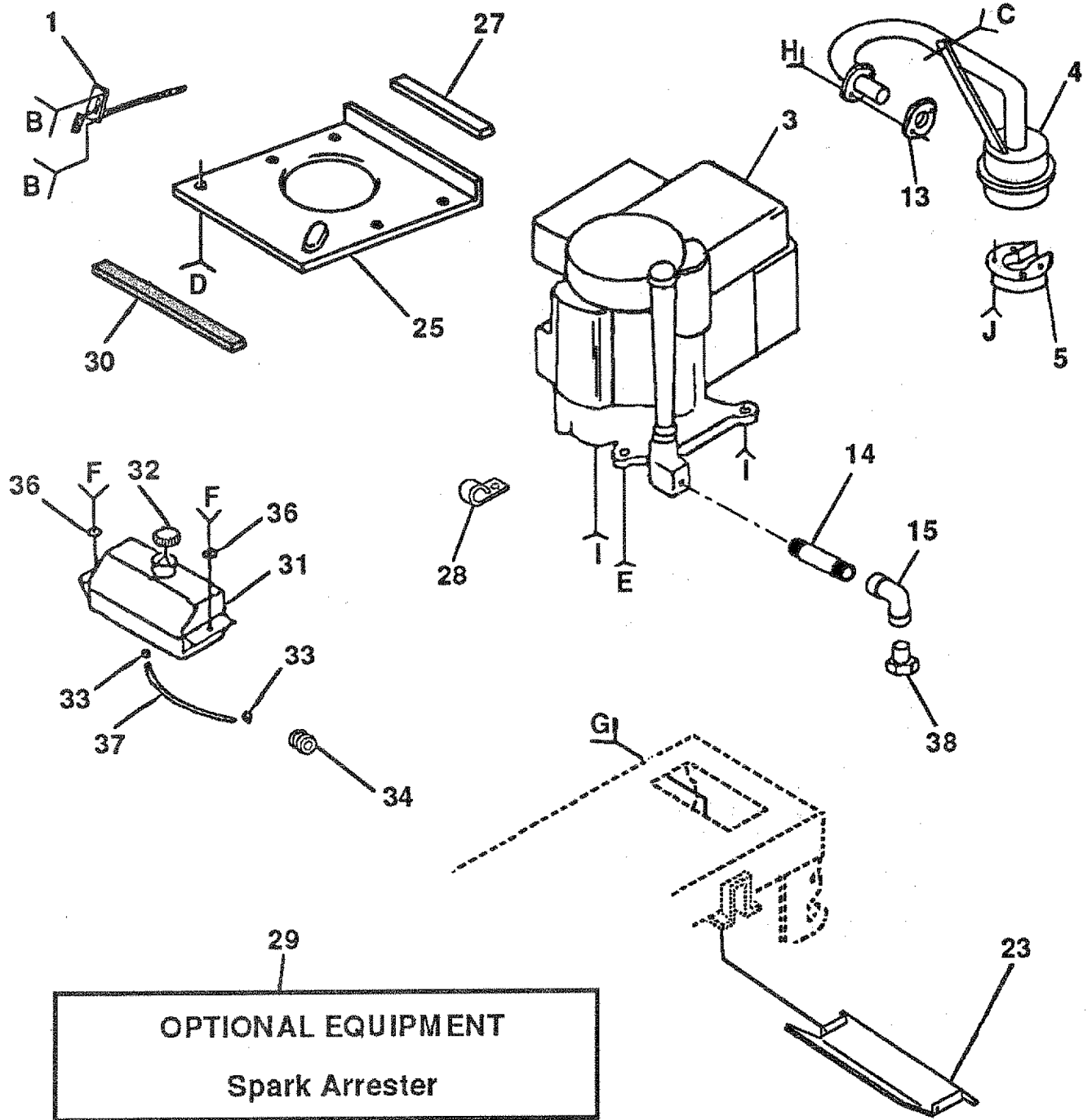

# REPAIR PARTS

12 HP 38" RIDING LAWN TRACTOR - - MODEL NUMBER 917.255560

## ENGINE

KEY PART NO. NO.	DESCRIPTION
1 132759	Control Throt Rh Blk Pdl 15 10
2 17720410	Screw Hex Thd Cut 1/4-20x5/8 T
3 131951	Engine B&s 12hp 1/c Dual 1 Vt
4 125610X	Muffler Exhaust B&s Lt Std
5 101326L	Deflector Muffler # 222573
6 17030808	Screw Spiderloc Hexhd#8x1/2 Ab
7 STD551025	*Washer 9/32 X 5/8 X 16 Ga
8 STD551125	*Washer Lock Hvy Helical 1/4
9 STD522510	*Bolt Fin Hex 1/4-20 Unc X 1
10 73220500	Nut Fin Hex 5/16-18 Unc
11 STD551131	*Washer Lock Hvy Hlcl Spr 5/16
12 71070510	Screw Hexhd Cap 5/16-18x5/8
13 125593X	Gasket 1 313 Id Tin Plated
14 13280324	Nipple Pipe 3/8 Npt X 3"
15 13200300	Elbow Std 90 Degree 3/8-18 Npt
16 STD551237	*Washer Lock Ext Tooth 3/8
17 17490620	Screw Thdrol 3/8-16x1-1/4 Tytt
18 105736X	Shield Pnt Heat
19 105839X	Receptacle 1/4 Turn Dacrotized
20 105838X	Retainer 1/4 Turn 365odx 222ld
21 STD551025	*Washer 9/32 X 5/8 X 16 Ga
22 123650X	Stud 1/4 Turn (replaces 105751
23 128953	Shield Pnt Heat Browning Grass
24 STD601005	*Screw Tap Hex #10-24unc X 1/2
25 124027X	Shield Pnt Heat Hood Lt
26 17030808	Screw Spiderloc Hexhd#8x1/2 Ab
27 105037X	Strip Foam 18"
28 2751R	Clip Line Fuel 13/32 Mtg Hole
29 121851X	Arrestor Spark
30 127057X	Strap Hood
31 109202X	Tank Fuel 1 25 Fr
32 123549X	Cap Asm Fuel W/sym Vented
33 123487X	Clamp Hose Blk
34 124028X	Bushing Snap Nyl Blk Fuel Line
35 17490412	Screw Hexwsh Thdrol 1/4-20x3/4
36 19091416	Washer 9/32 X 7/8 X 16ga
37 101335K	Line Fuel 9 50"
38 - - -	Plug Oil Drain (Order From Engine Manufacturer)

\* STANDARD HARDWARE - - PURCHASE LOCALLY  
NOTE: All component dimensions given in U.S. inches  
1 Inch = 25.4 mm





# REPAIR PARTS

12 HP 38" RIDING LAWN TRACTOR - - MODEL NUMBER 917.255560

38" MOWER

KEY PART NO. NO.	DESCRIPTION	KEY PART NO. NO.	DESCRIPTION
1	129365 Mower Asm 38"welded	45	STD541437 * Nut, Crownlock 3/8-16
2	STD541431 * Nut, Crownlock 5/16-18	46	131290 Belt
3	STD533107 * Bolt, Carriage 5/16-18 x 3/4	47	133502 Spacer, Retainer
4	7631J Runner, L. H.	48	133503 Stiffener, Arm Idler
5	110485X Bearing, Ball, Mandrel	49	120183X Bearing, Nylon
6	128774 Housing Asm., Mandrel Vented (machd)	50	122507X Shaft Asm., Lift
7	129895 Bearing, Ball	51	105767X Pin, Groove
8	133172 Shaft and Bearing Asm.	52	125631X Grip, Handle
9	127842 Blade, Mower, High Performance	53	122365X Button, Plunger
10	129962 Washer, Hard, Mower, Vented	54	122364X Plunger, Lever
11	STD551137 * Washer, Lock Hvy 3/8	55	122512X Spring
12	850857 Bolt, Blade 3/8-24 x 1-1/4 Gr. 8	56	122514X Rod, Lever
13	128961 Stripper, Mower, Vented	57	STD581062 * Ring, E
14	106736X Shield, Deflector	58	19211416 Washer 21/32 x 7/8 x 16 Ga.
15	106735X Rod, Hinge	59	131288 Rod, Brake, R. H.
16	105896X Bracket, Deflector, Mower	60	131289 Rod, Brake, L. H.
17	110452X Nut, Push	61	STD560907 * Pin, Cotter 3/32 x 3/4
18	106734X Spring, Deflector	62	133551 Rod, Pivot
19	19111016 Washer 11/32 x 3/4 x 16 Ga.	63	133504 Rod, Clutch, Secondary
20	105304X Cap, Sleeve	64	STD533717 * Bolt, Carriage 3/8-16 x 1-3/4
21	128772 Runner, R. H.	65	133550 Rod, Clutch, Primary →
22	19111216 Washer 11/32 x 3/4 x 16 Ga.	66	73350600 Nut, Hex Jam 3/8-16
23	78158 Bolt, Mandrel	67	133205 Trunnion 3/8-16
24	STD624008 * Retainer, Spring	68	STD624003 * Retainer, Spring
25	74600636 Bolt, Hex Hd. 3/8-16 x 2.25	69	127498 Bushing
26	851074 Washer, Wear 7 Ga.	70	128759 Spring
27	127218 Link, Front	71	133573 Arm, Clutch Primary Asm.
28	73350800 Nut, Jam Hex 1/2-13	72	106932X Knob
29	130171 Trunnion	73	121748X Washer 25/32 x 1-5/8 x 16 Ga.
30	73680800 Nut, Crownlock 1/2-13	74	12000029 Ring, Klip
31	127224 Lift, Link, R. H.	75	128903 Bolt, Shoulder
32	128763 Pin, Spring 5/16-3/4	76	127845 Keeper, Spring
33	133710 Arm, Suspension, Rear Asm.	77	127847 Arm, Clutch, Secondary
34	127223 Link, Lift, R. H.	78	131870 Spring, Return
35	STD541343 * Nut, Hex Jam ASF 7/16-20 UNF	79	130840 Brake Ass., Mower, Vented
36	110447X Trunnion, Lift	80	17490512 Screw, Hex, Thd. Rol. 5/16-18 x 3/4
37	73710700 Nut, Crownlock Jam 7/16-20 UNF	--	131529 Deck, Complete Mower
38	133736 Idler Arm Asm.	--	130794 Mandrel Assembly (Includes Key Numbers 5-8, 10-12, 39 and 41)
39	129963 Washer, Spacer Mower, Vented		
40	129206 Pulley, Mandrel, Single		
41	73050900 Nut, Flangelock 9/16		
42	131494 Pulley, Idler, Flat		
43	122052X Spacer, Retainer 1-3/4		
44	19131612 Washer 13/32 x 1 x 12 Ga.		

\* STANDARD HARDWARE - - PURCHASE LOCALLY

NOTE: All component dimensions given in U.S. inches  
1 inch = 25.4 mm

# REPAIR PARTS

12 HP 38" RIDING LAWN TRACTOR - - MODEL NUMBER 917.255560  
FOOTE/DANA TRANSAXLE - MODEL NUMBER ~~140.4360-06~~

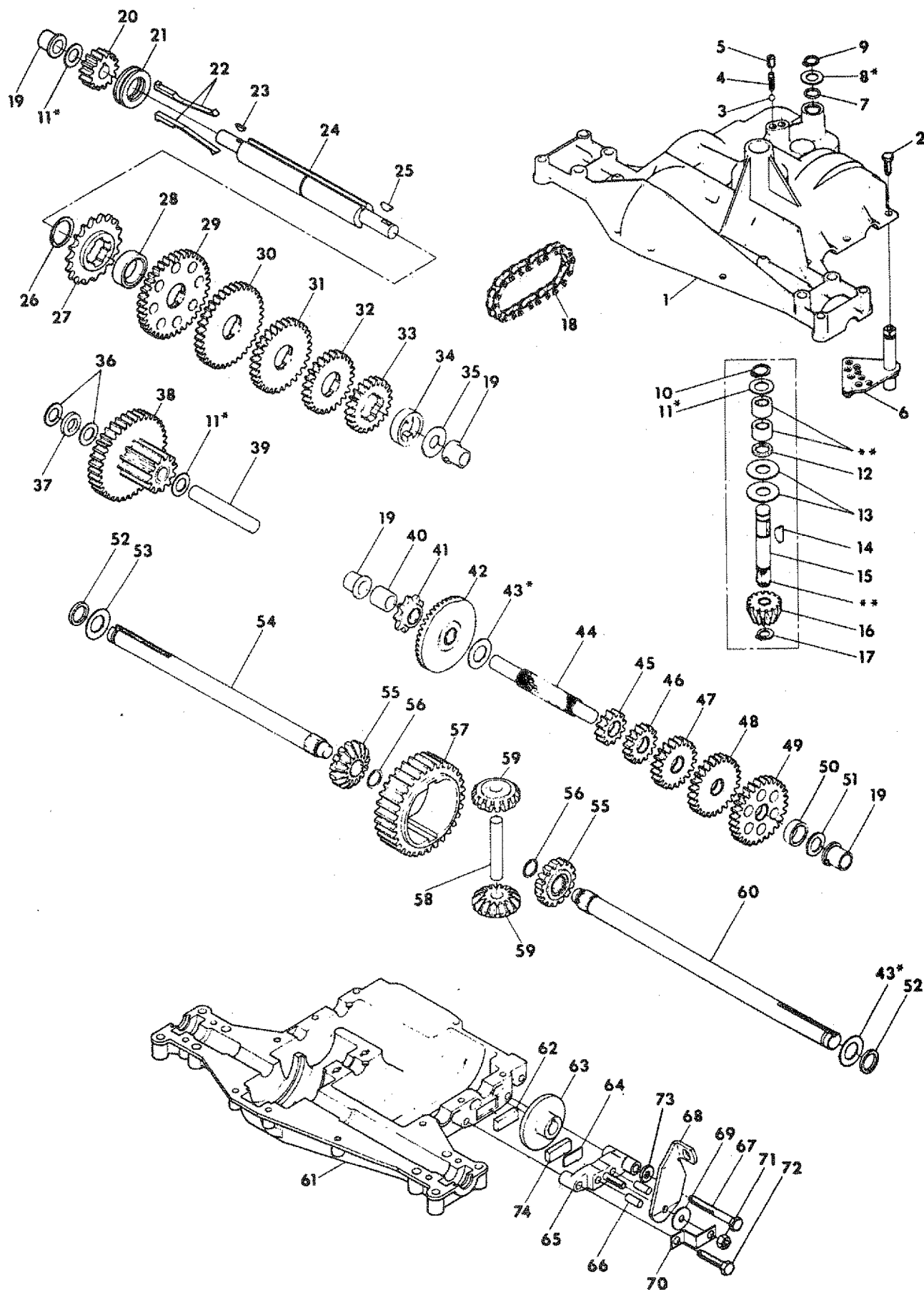

# REPAIR PARTS

12 HP 38" RIDING LAWN TRACTOR - - MODEL NUMBER 917.255560  
FOOTE/DANA TRANSAXLE - MODEL NUMBER 143-4380-06

KEY PART NO. NO.	DESCRIPTION	KEY PART NO. NO.	DESCRIPTION
1	120458X Housing, Upper	41	105928X Sprocket, 9 Teeth
2	2274J Screw, Tapping, Large 1/4-20 x .734	42	110084X Gear, Bevel, 42 Teeth
3	68003 Ball, Detent	43	108983X * Washer, Plain .758 x 1.12 x .010
4	105904X Spring, Detent		105930X * Washer, Plain .758 x 1.12 x .015
5	105905X Screw, Set		105931X * Washer, Plain .758 x 1.12 x .020
6	120460X Shifter Assembly		105932X * Washer, Plain .758 x 1.12 x .025
7	120461X O-Ring		3417J * Washer, Plain .758 x 1.25 x .020
8	120462X * Washer, Plain .505 x .942 x .006		106097X * Washer, Plain .758 x 1.25 x .025
	120463X * Washer, Plain .505 x .942 x .010		2264J * Washer, Plain .758 x 1.25 x .031
	120464X * Washer, Plain .505 x .942 x .015		106098X * Washer, Plain .758 x 1.25 x .035
	120465X * Washer, Plain .505 x .942 x .020		2265J * Washer, Plain .758 x 1.25 x .040
	120466X * Washer, Plain .505 x .942 x .026		106586X * Washer, Plain .758 x 1.25 x .045
	83818 * Washer, Plain .505 x .942 x .030		106587X * Washer, Plain .758 x 1.25 x .050
	120467X * Washer, Plain .505 x .942 x .040		106588X * Washer, Plain .758 x 1.25 x .055
9	2286J Ring, Retaining		2263J * Washer, Plain .758 x 1.25 x .062
10	2267J Ring, Retaining	44	120473X Shaft, Drive
11	3413J * Washer, Plain .632 x 1.00 x .010	45	105933X Gear, Spur, 12 Teeth
	2233J * Washer, Plain .632 x 1.00 x .020	46	120407X Gear, Spur, 20 Teeth
	2232J * Washer, Plain .632 x 1.00 x .026	47	106589X Gear, Spur, 25 Teeth
	2231J * Washer, Plain .632 x 1.00 x .031	48	120408X Gear, Spur, 28 Teeth
	2230J * Washer, Plain .632 x 1.00 x .036	49	105937X Gear, Spur, 31 Teeth
	2229J * Washer, Plain .632 x 1.00 x .041	50	105936X Spacer .781 x 1.00 x .375
	2228J * Washer, Plain .632 x 1.00 x .046	51	2226J Washer, Plain .632 x 1.00 x .060
	2227J * Washer, Plain .632 x 1.00 x .050	52	2227J Seal, Felt
	2226J * Washer, Plain .632 x 1.00 x .060	53	2263J Washer, Plain .758 x 1.25 x .062
	105906X * Washer, Plain .632 x 1.00 x .082	54	120474X Axle, Left Hand
12	6725J O-Ring	55	110081X Gear, Miter, 15 Teeth
13	120415X Washer, Plain .632 x 1.38 x .046	56	105941X Ring, Retaining
14	2257J Key, Woodruff, #9	57	110071X Gear, Spur, 32 Teeth
15	110077X Kit, Input Shaft Assembly	58	120952X Shaft, Cross
16	110078X Pinion, Bevel, 14 Teeth	59	110082X Gear, Miter, 15 Teeth
17	105909X Ring, Retaining	60	120475X Axle, Right Hand
18	105910X Chain, 24 Pitches	61	120476X Housing, Lower
19	105911X Bearing, Flange	62	120961X Puck, Friction
20	108976X Gear, Spur, 14 Teeth	63	7294J Disc, Brake
21	105913X Collar, Clutch	64	108989 Spacer
22	120468X Key, Clutch	65	120953X Jaw, Brake
23	2242J Key, Woodruff, #3	66	120954X Pin, Dowel
24	120469X Shaft, Intermediate	67	120955X Screw, Tapping, Large 5/16-18 x 2.25
25	2244J Key, Woodruff, #61	68	108992X Lever, Actuating
26	105916X Ring, Retaining	69	108996X Washer, Plain .321 x 1.00 x .055
27	120470X Sprocket, 18 Teeth	70	120956X Bracket, Anti-Rotation
28	110070X Spacer	71	73810500 Locknut 5/16-24
29	108977X Gear, Spur, 37 Teeth	72	106596X Screw, Tapping, Large 5/16-18 x 1.44
30	120405X Gear, Spur, 30 Teeth	73	120993X Washer, Plain .343 x .81 x .059
31	108980X Gear, Spur, 25 Teeth	74	120951X Puck, Friction
32	120406X Gear, Spur, 22 Teeth	75	120416X Grease
33	108455X Gear, Spur, 19 Teeth		
34	105923X Spacer 1.133 x 1.50 x .375		
35	105825X Washer, Plain .640 x 1.37 x .061		
36	2232J Washer, Plain .632 x 1.00 x .026		
37	108978X Spacer .630 x 1.00 x .169		
38	110079X Assembly, Gear, Combination of 12 Teeth and 35 Teeth		
39	120471X Shaft, Idler		
40	120472X Spacer .635 x .875 x .755		

\* Use In Various Combinations To Maintain Proper Clearances

\*\* Order Key Number 15

NOTE: All component dimensions given in U.S. inches  
1 inch = 25.4 mm



# REPAIR PARTS

12 HP 38" RIDING LAWN TRACTOR - - MODEL NUMBER 917.255560  
BRIGGS & STRATTON ENGINE - MODEL NUMBER 283707, TYPE NUMBER 0217-01

## 121 CARBURETOR OVERHAUL KIT

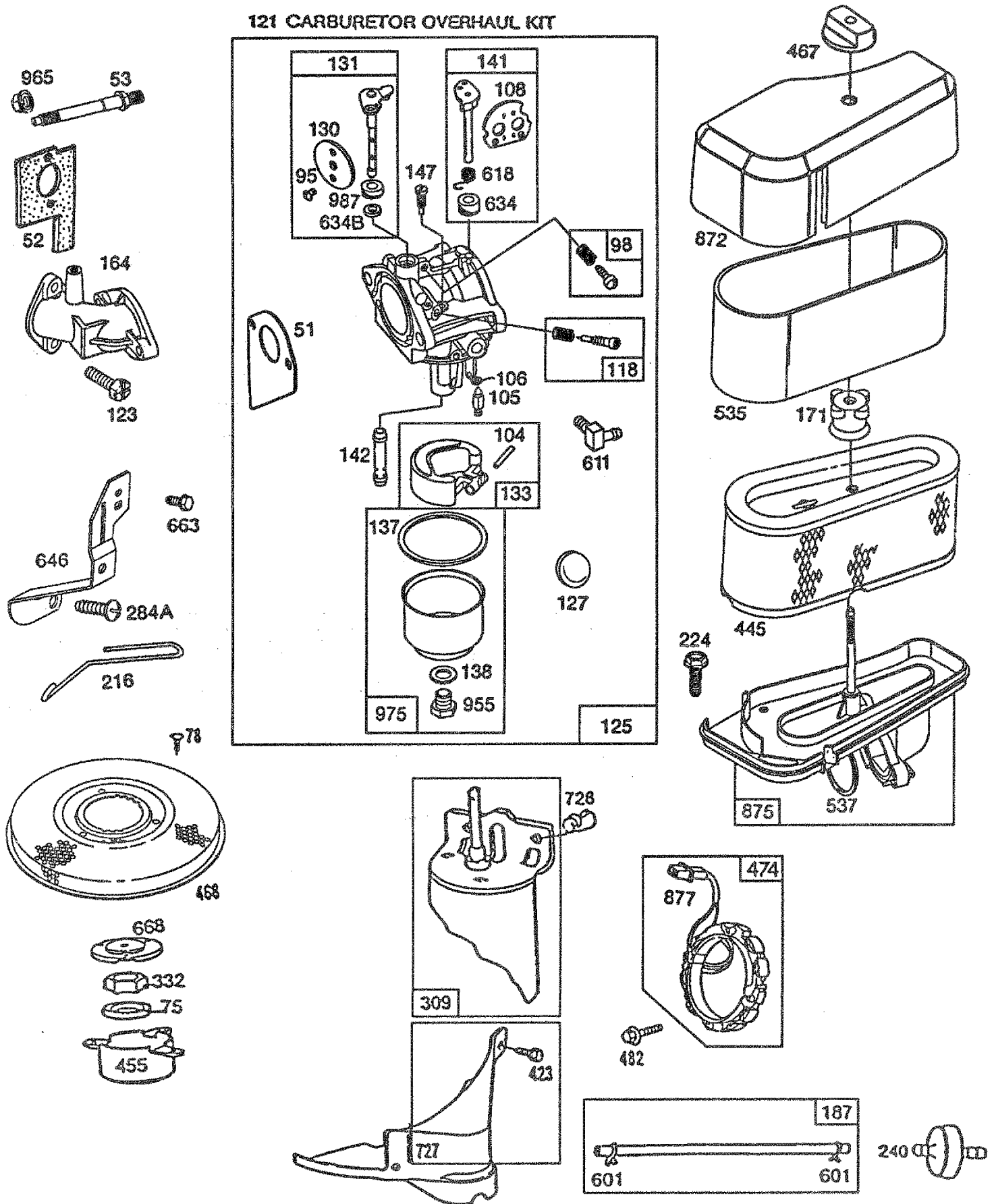

# REPAIR PARTS

12 HP 38" RIDING LAWN TRACTOR - - MODEL NUMBER 917.255560  
 BRIGGS & STRATTON ENGINE - MODEL NUMBER 283707, TYPE NUMBER 0217-01

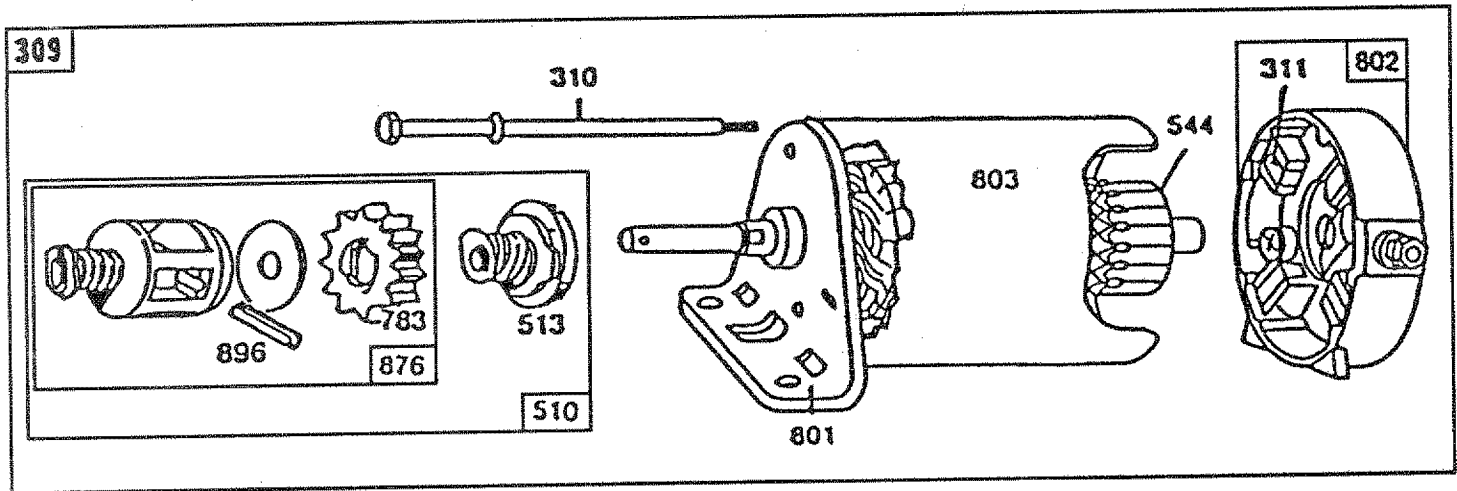

Reference Number		309	310	311	510	544	801	802	803
Manufacturer		Motor and Drive Ass'y.	Thru Bolt Assembly	Brush Assembly	Drive Assembly	Armature Assembly	Drive End Cap Assembly	End Cap Ass'y. Commutator	Housing Assembly
Briggs & Stratton	Housing Length								
12V	3-21/32"	394805	94003	395538	490421**	390837	394856	395537*	393825

\*Includes Brush Set  
 \*\*Includes #398003 Clutch Assembly (Ref. No. 513)  
 #280104 Gear (Ref. No. 783)  
 #490467 Retainer and Pin (Ref. No. 876)  
 # 94288 Roll Pin (Ref. No. 896)

# REPAIR PARTS

12 HP 38" RIDING LAWN TRACTOR - - MODEL NUMBER 917.255560

BRIGGS & STRATTON ENGINE - MODEL NUMBER 283707, TYPE NUMBER 0217-01

KEY PART NO.	NO.	DESCRIPTION	KEY PART NO.	NO.	DESCRIPTION
1	490450	Cylinder Assembly	53	94637	Stud, Carburetor Mounting
2	399265	Bearing, Cylinder (Requires Special Tools For Installation)	75	224061	Washer, Spring
3	391086	* Seal, Oil	78	93805	Screw, Sems
5	494240	Head, Cylinder	95	94098	** Screw, Throttle
7	271866	* Gasket, Cylinder Head	98	494382	Screw, Idle Speed
8	391406	Breather Assembly	104	231789	** Pin, Float Hinge
9	27803	* Gasket, Valve Cover	105	231790	** Valve Assembly, Inlet Needle
10	93394	Screw, Sems	106	281169	Inlet, Valve Seat
11	280100	Tube, Breather	108	224540	Valve, Choke
12	271916	* Gasket, Crankcase Cover 1/64"	118	494383	** Valve, Needle
	271997	* Gasket, Crankcase Cover .005"	121	494384	Carburetor Overhaul Kit
	271996	* Gasket, Crankcase Cover .009"	123	94616	Screw, Elbow Mounting
13	93723	Screw, Cylinder Head	125	494502	Carburetor Assembly
15	94239	Plug, Oil Drain	127	- - -	** Plug, Welch (Sold in Kit Only)
16	490466	Crankshaft	130	224539	Valve, Throttle
	94196	Key, Timing Gear	131	494379	Shaft and Lever, Throttle
18	494238	Base, Engine	133	494381	Float, Carburetor
20	291675	* Seal, Oil	137	281165	*** Gasket, Float Bowl
22	94305	Screw, Sems, Base Mounting	138	281164	*** Washer, Float Bowl Screw
23	492326	Flywheel and Ring Gear Assembly, Magneto	141	494380	** Shaft and Lever, Choke
24	222698	Key, Flywheel	142	494537	** Nozzle / Jet, Carburetor
25	394661	Piston Assembly, Standard		494499	High Altitude Kit:
	394662	Piston Assembly .010" Oversize	147	231794	231796 Pilot, Jet, High Altitude
	394663	Piston Assembly .020" Oversize	164	213819	281164 Seal, Bowl Screw
	394664	Piston Assembly .030" Oversize	171	281051	** Pilot, Jet
26	391780	Ring Set, Piston, Standard Size	187	393815	Carburetor, Elbow
	392331	Ring Set, Piston, Chrome, Standard	188	93535	Nut, Air Cleaner Mounting
	391781	Ring Set, Piston .010" Oversize	201	262767	Line, Fuel
	391782	Ring Set, Piston .020" Oversize	209	260871	Screw, Sems
	391783	Ring Set, Piston .030" Oversize	216	262766	Link, Governor
27	260924	Lock, Piston Pin	219	490815	Spring, Governor
28	299691	Pin Assembly, Piston, Standard			Link, Choke
	391286	Pin Assy., Piston .005" Oversize	222	494887	Oil Slinger, Governor Gear and Bracket Assembly
29	490348	Rod Assembly, Connecting			Plate, Governor Control (Choke-A-Matic)
	490469	Rod Assembly, Connecting, .020" Undersize Crankpin Bore	224	94513	Screw, Sems, Air Cleaner
31	222299	Lock, Connecting Rod Screw	225	231058	Crank, Governor
32	92909	Screw, Connecting Rod	227	493935	Lever Assembly, Governor
33	262246	Valve, Exhaust	230	222450	Washer, Governor Crank
34	262247	Valve, Intake	232	262785	Spring, Governor Link
35	65906	Spring, Intake Valve	240	394358	Filter, Fuel
36	26828	Spring, Exhaust Valve			
37	223752	Guard, Flywheel			
40	221596	Retainer, Intake Valve			
41	292260	Rotocoil, Exhaust Valve			
42	93630	Retainer, Exhaust Valve Rotocoil			
45	262248	Tappet, Valve			
46	212897	Gear, Cam			
51	272465	*** Gasket, Carburetor (Carburetor to Elbow)			
52	270872	* Gasket, Carburetor (Elbow to Cylinder)			

\* Included in Gasket Set (494241)  
 \*\* Included in Carburetor Overhaul Kit (494384)  
 \*\*\* Included in both Carburetor Overhaul Kit (494384) and Carburetor Gasket Set (494385)

NOTE: All component dimensions given in U.S. inches  
 1 inch = 25.4 mm

# REPAIR PARTS

12 HP 38" RIDING LAWN TRACTOR - - MODEL NUMBER 917.255560  
 BRIGGS & STRATTON ENGINE - MODEL NUMBER 283707, TYPE NUMBER 0217-01

KEY PART NO. NO.	DESCRIPTION	KEY PART NO. NO.	DESCRIPTION
265 221535	Clamp, Casing	635 66538	Elbow, Spark Plug
284 94419	Screw, Clamp Mounting	646 224546	Brace, Air Cleaner
284A 94326	Screw, Air Cleaner	657 93496	Screw, Sems
304 494269	Housing, Blower	663 94620	Screw, Hex Head
305 94608	Screw, Sems, Blower Housing Mounting	668 280848	Spacer
306 224545	Shield, Cylinder	726 392134	Gear, Ring (Includes Mounting Parts)
307 93949	Screw, Sems, Cylinder Shield Mounting	727 490324	Cover, Starter (Includes Mounting Screws)
308 491490	Cover, Cylinder Head	728 94627	Screw, Sems
309 - - -	Motor, Starting (See Chart on Illustrated Pages for Replacement Parts for Starting Motors)	729 281159	Clip, Lead Wire
332 92284	Nut, Hex	741 262135	Gear, Timing
333 492341	Armature, Magneto	757 212359	Link, Counterweight
334 93381	Screw, Sems, Armature Mounting	758 399891	Counterweight Assembly
337 802592	Plug, Spark	759 298909	Pin, Counterweight
346 93705	Screw, Hex Head	761 93875	Screw, Counterweight
356 494328	Wire, Ground	842 270920	Seal, Oil Filler Cap
358 494241	Gasket Set	847 490474	Fill Group, Oil
363 19203	Puller, Flywheel	851 221798	Terminal, Ignition Cable
383 89838	Wrench, Spark Plug	869 261463	Seat, Intake Valve, Standard
422 223721	Clamp, Oil Filler Tube	870 213316	Seat, Exhaust Valve, Standard
423 94073	Screw, Sems	871 261961	Guide, Exhaust Valve
445 493909	Cartridge, Air Cleaner	872 281104	Cover, Air Cleaner
455 222561	Cup, Screen Mounting	875 494237	Body, Air Cleaner
467 493903	Knob, Air Cleaner	877 393456	Diode and Connector Assembly, Dual Circuit
468 222562	Screen, Flush Rotating	955 94642	** Screw, Fuel Bowl
474 393474	Stator, Alternator	965 94108	Locknut, Air Cleaner Mounting
482 93621	Screw, Sems	975 494378	Bowl Assembly, Carburetor
523 490327	Cap and Dipstick, Oil Filler	977 494385	Carburetor Gasket Kit
524 68838	Seal, Filler Tube	987 281166	** Seal, Throttle Shaft
525 280741	Tube, Oil Filler	1005 280687	Fan, Flywheel
535 272403	Element, Air Cleaner	1006 224413	Retainer, Fan
537 281106	* O-Ring, Air Cleaner	1020 262243	Eccentric
552 231597	Bushing, Governor Crank	1021 94160	Pin, Eccentric
562 92613	Bolt, Governor Lever		
592 231082	Nut, Hex #10-24		
601 93053	Clamp, Fuel Pipe		
611 494451	Fuel Inlet Tube		
614 93306	Cotter, Hair Pin		
615 93307	Retainer, E-Ring		
618 262803	Spring, Choke Return		
634 281168	** Seal, Choke Shaft		
634A 491323	* Seal, Governor		
634B 281167	Washer, Throttle Shaft		

\* Included in Gasket Set (494241)  
 \*\* Included in Carburetor Overhaul Kit (494384)  
 \*\*\* Included in both Carburetor Overhaul Kit (494384) and Carburetor Gasket Set (494385)

NOTE: All component dimensions given in U.S. inches  
 1 inch = 25.4 mm



---

# SERVICE NOTES

---

---

# SERVICE NOTES

---

# SUGGESTED GUIDE FOR SIGHTING SLOPES FOR SAFE OPERATION

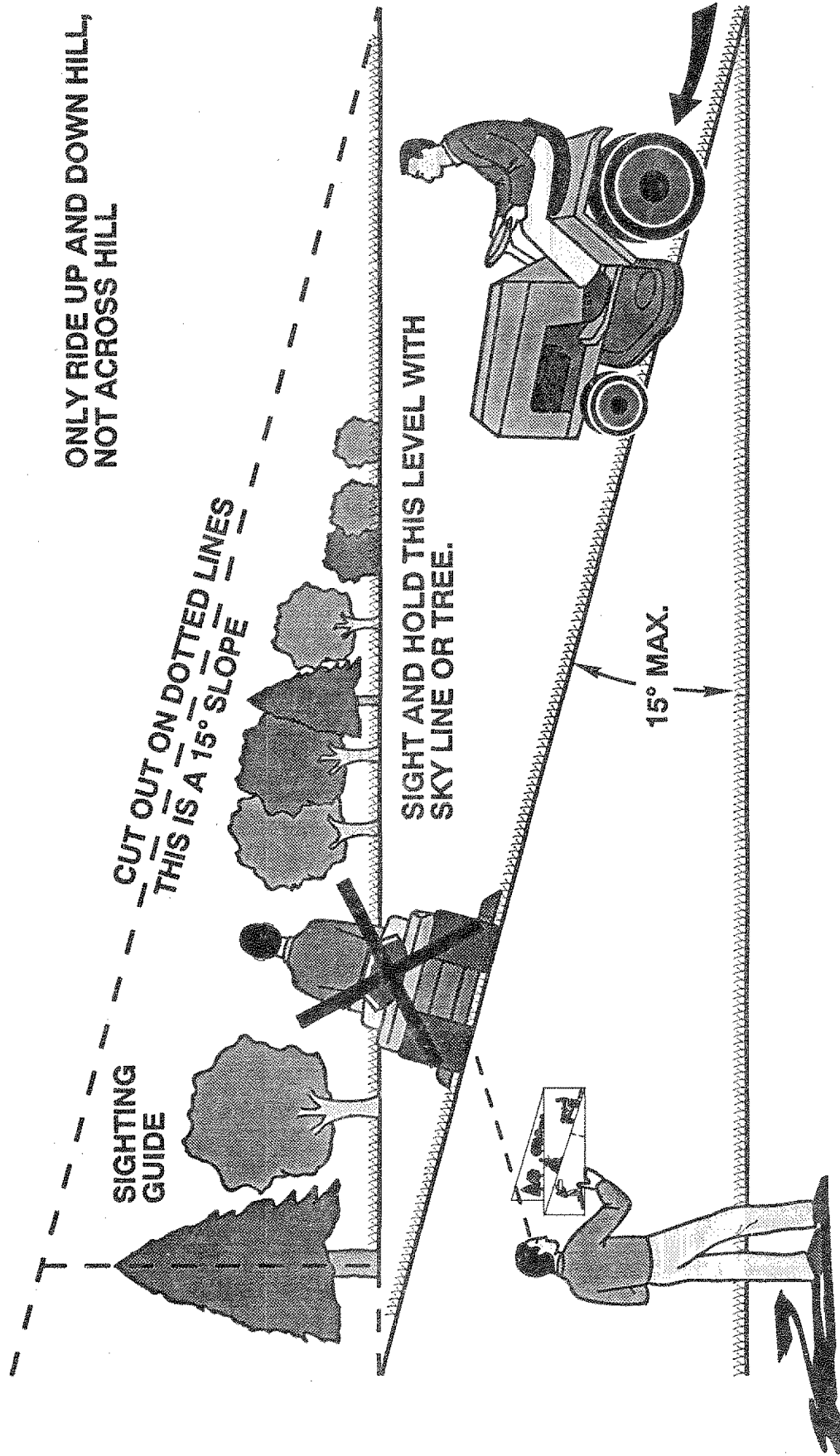

Operate your Tractor up and down the face of slopes (not greater than 15°), never across the face. Make turns gradually to prevent tipping or loss of control. Exercise extreme caution when changing direction on slopes.



# **SEARS**

## **OWNER'S MANUAL**

### **MODEL NO. 917.255560**

### **HOW TO ORDER REPAIR PARTS**

# **CRAFTSMAN<sup>®</sup>**

## **12.0 HP IC ELECTRIC START 38" MOWER DECK 5 SPEED TRANSAXLE LAWN TRACTOR**

Each tractor has its own model number. Each engine has its own model number.

The model number for your tractor will be found on the model plate located under the seat.

The model number for your engine will be found on the blower housing.

All parts listed herein may be ordered from any Sears, Roebuck and Co. Service Centers and most Retail Stores.

**WHEN ORDERING REPAIR PARTS, ALWAYS GIVE THE FOLLOWING INFORMATION:**

- **PRODUCT - LAWN TRACTOR**
- **MODEL NUMBER - 917.255560**
- **ENGINE MODEL NUMBER - 283707, TYPE NUMBER 0217-01**
- **PART NUMBER**
- **PART DESCRIPTION**

Your Sears merchandise has added value when you consider Sears has service units nationwide staffed with Sears trained technicians... professional technicians specifically trained to insure that we meet our pledge to you, we service what we sell.

**Sears, Roebuck and Co., Chicago, IL 60684 U.S.A.**