

PORTABLE AIR CONDITIONER

USER' S GUIDE & INSTALLATION INSTRUCTIONS

Please retain this owner's manual for future
reference.
Read and follow all safety rules and instructions
before using this product.

CLIMATISEUR MOBILE

GUIDE DE L' UTILISATEUR ET INSTRUCTIONS D' INSTALLATION

Veuillez conserver ce manuel de l'utilisateur
pour référence future.
Lisez et suivez toutes les règles et les
instructions relatives à la sécurité avant
d'utiliser ce produit.

ACONDICIONADOR DE AIRE PORTÁTIL

GUÍA DE USUARIO E INSTRUCCIONES DE INSTALACIÓN

Guarde este manual de usuario para referencia
futura. Lea y siga todas
las reglas e instrucciones de seguridad antes
de utilizar este producto.

Model/Modèle/Modelo
LP1200DXR

P/No. MFL36812504

To contact LG Electronics, 24 hours a day,
7 days a week:

1-800-243-0000 (US)

1-888-542-2623 (Canada)

Or visit us on the Web at: us.lge.com

Pour contacter LG Electronics, 24 heures
par jour, 7 jours par semaine, appelez le :

1-800-243-0000 (US)

1-888-542-2623 (Canada)

Ou visitez-nous sur le Web à l'adresse :
us.lge.com

Para comunicarse con LG Electronics,
24 horas al día, 7 días a la semana:

1-800-243-0000

O visítenos en la Web en: us.lge.com

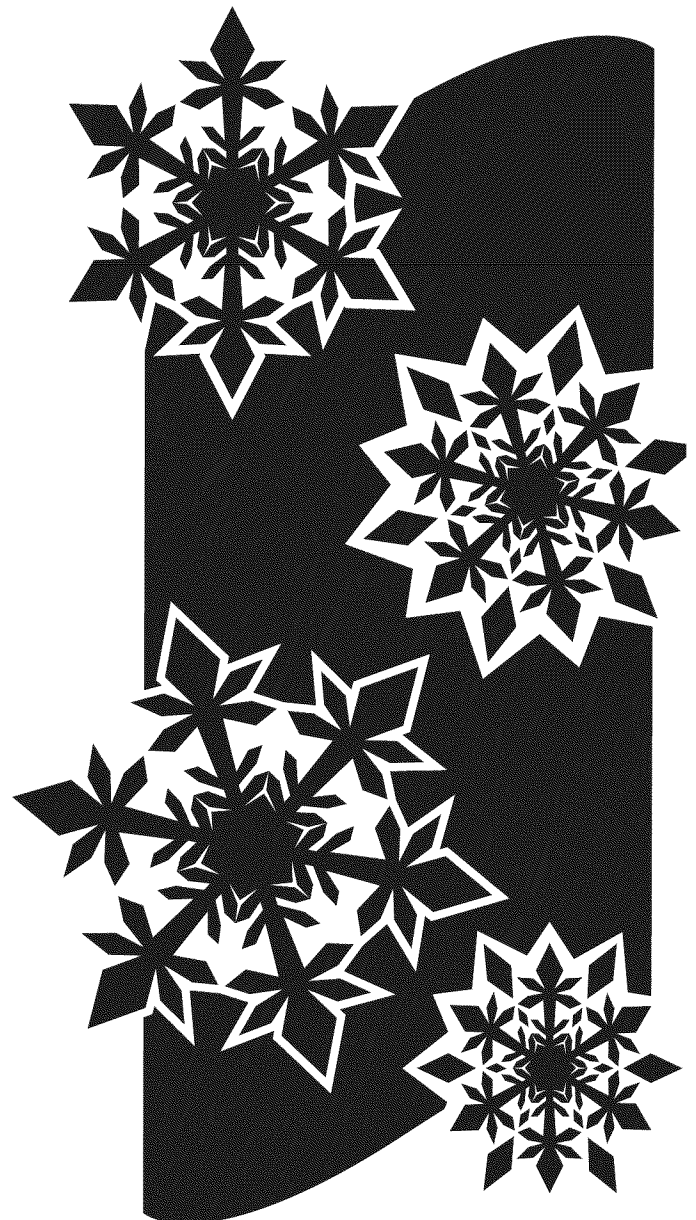

English

Français

Español

INTRODUCTION

IMPORTANT SAFETY INSTRUCTIONS

Basic Safety Precautions	3, 4
Electrical Safety	4, 5

PARTS AND FEATURES

Key Parts and Components	6
Control Panel and Remote	7

HOW TO USE

Before Using Your Air Conditioner	8, 9
Using the Controls	10–12

INSTALLATION INSTRUCTIONS

Preparing for Installation	13
Attaching the Hose and Diffuser	14
Attaching the Rain Shield	14
Window Vent Panel and Extensions	15
Installation in Vertical Sliding Windows	16, 17
Installation in Casement Windows	18, 19

CARE AND CLEANING

Cleaning the Case	20
Cleaning the Air Filter	20
Emptying the Water Collection Tank	21
Using the Optional Drain Hose	21, 22
Storing the Air Conditioner	22

TROUBLESHOOTING

Before Calling for Service	23, 24
--------------------------------------	--------

WARRANTY

Product Registration Information	25
--	----

THANK YOU!

Congratulations on your purchase and welcome to the LG family.

Your new LG Air Conditioner combines high-efficiency operation with portable convenience.

By following the operating and care instructions in this manual, your air conditioner will provide you with many years of reliable service.

IMPORTANT SAFETY INSTRUCTIONS

READ ALL INSTRUCTIONS BEFORE USE

Your safety and the safety of others is very important.

We have provided many important safety messages in this manual and on your appliance. Always read and obey all safety messages.



This is the safety alert symbol.

This symbol alerts you to potential hazards that can kill or hurt you and others.

All safety messages will follow the safety alert symbol and either the word “WARNING” or “CAUTION”. These words mean:

▲ WARNING This symbol indicates the possibility of death or serious injury.

▲ CAUTION This symbol indicates the possibility of injury or damage to property.

BASIC SAFETY PRECAUTIONS



WARNING To reduce the risk of fire, electric shock, or injury

to persons when using this appliance, follow basic precautions, including the following:

- Do not attempt to repair or replace any part of your air conditioner unless it is specifically recommended in this manual. All other services should be referred to a qualified technician.
- If the power cord becomes worn or damaged, the cord should only be replaced by a qualified service technician using genuine replacement parts.
- The air conditioner should be plugged into its own grounded 15A, 60 Hz., 120 VAC circuit.
- Do not plug other appliances into the same outlet; it can overload the circuit and cause a fire or electric shock.
- Do not remove the round grounding prong from the plug. It can result in the risk of electric shock.
- This air conditioner is not designed for use by young children. Young children should be supervised to ensure that they do not play with or climb on the air conditioner.
- Be sure all packaging materials are removed from the air conditioner before use. It can result in personal injury.
- Do not disassemble or modify the air conditioner or the power cord. It can result in the risk of electric shock or fire.
- Do not place the power cord or air conditioner near a heater, radiator, or other heat source. It can result in the risk of electric shock or fire.
- Do not use this or any appliance near flammable gases or liquids or other combustibles, such as gasoline, benzene, thinner, etc. It can result in the risk of electric shock or fire.
- Make sure the power cord is plugged firmly and completely into the outlet. It can result in the risk of electric shock or fire.
- Do not start or stop operation by plugging in or unplugging the power cord. It can result in the risk of electric shock.
- If the air conditioner is making unusual sounds or is emitting smoke or an unusual odor, unplug it immediately. It can result in the risk of electric shock or fire.
- Do not use if the electrical socket is loose or damaged. It can result in the risk of electric shock or fire.
- Do not operate with wet hands or in a damp environment. It can result in the risk of electric shock.
- Do not use this or any electrical appliance if you smell gas. It can result in the risk of fire or explosion.
- Turn off and unplug the air conditioner before cleaning to avoid the risk of electric shock.
- Do not clean the unit with water. Water can enter the unit and damage the insulation, creating a shock hazard. If water enters the unit, unplug it immediately and contact Customer Service. It can result in the risk of electric shock.
- Use two or more people to lift and install the unit. Failure to do so can cause back injury or other injuries.



IMPORTANT SAFETY INSTRUCTIONS

READ ALL INSTRUCTIONS BEFORE USE

BASIC SAFETY PRECAUTIONS

⚠ CAUTION To reduce the risk of fire, electric shock, or injury to persons when using this appliance, follow basic precautions, including the following:

- To avoid possible cuts, avoid contacting the metal parts of the air conditioner when removing or reinstalling the filter. It can result in the risk of personal injury.
- Do not block the air inlet or outlet of the air conditioner. Reduced air flow will result in poor performance and could damage the unit.
- Always grasp the plug when plugging in or unplugging the air conditioner. Never unplug by pulling on the cord. It can result in the risk of electrical shock and damage.
- Always turn off and unplug the air conditioner when it will not be used for extended period of time. This conserves energy and reduces the chance of accidents.
- Secure the wheels with blocks to prevent the air conditioner from rolling on smooth floors.
- Install the air conditioner on a sturdy, level floor capable of supporting up to 110 lbs (50 kg). Installation on a weak or unlevel floor can result in the risk of property damage and personal injury.
- Make sure the air conditioner is the correct size for the area you wish to cool. Using an air conditioner that is the wrong size can waste energy and damage the air conditioner.
- Close all doors and windows to the room for most efficient operation.
- To prevent damage to the surface finish, use only a soft cloth to clean the air conditioner. Do not use wax, thinner, or a strong detergent.
- To prevent spills and property damage, be sure to drain the air conditioner properly.
- To prevent the coils from freezing, do not operate the air conditioner if the room temperature is below 65°F (18°C).
- Do not position the air conditioner so that pets or house plants are exposed to the direct air flow. It can result in the risk of injury to pets or house plants.
- This air conditioner is designed for normal household use. Do not use for cooling pets, foods, precision machinery, or art objects.
- Do not drink the water from the drain pan. Dispose of it properly outdoors or down the drain.
- Do not operate air conditioner without the filter securely in place. Operation without the filter could damage the unit.
- Clean the filter every two weeks, or more often if needed.
- If you eat the liquid from the batteries, brush your teeth and see doctor. Do not use the remote if the batteries have leaked. The chemicals in batteries could cause burns or other health hazard.
- If the liquid from the batteries gets onto your skin or clothes, wash it well with clean water. Do not use the remote if the batteries have leaked. The chemicals in batteries could cause burns or other health hazard.

ELECTRICAL SAFETY

⚠ WARNING

Electrical Shock Hazard

Failure to follow these instructions can result in death, fire, or electrical shock.

- This unit must be properly grounded.
- Do not, under any circumstances, cut or remove the ground prong.
- If you do not have a properly grounded outlet, or if there is any doubt that the outlet is not properly grounded, a qualified electrician should check the outlet and circuit, and, if necessary, install a properly grounded outlet.
- This air conditioner must be plugged into a grounded 60 Hz, 120 VAC outlet protected by a 15 amp time delay fuse or circuit breaker.
- This air conditioner must be installed in accordance with national wiring codes.
- Do not alter or modify the plug or cord of this air conditioner. If the power cord becomes worn or damaged, the cord should only be replaced by a qualified service technician using genuine replacement parts.
- Do not use an extension cord.

IMPORTANT SAFETY INSTRUCTIONS

READ ALL INSTRUCTIONS BEFORE USE

ELECTRICAL SAFETY

INTEGRATED CIRCUIT BREAKER

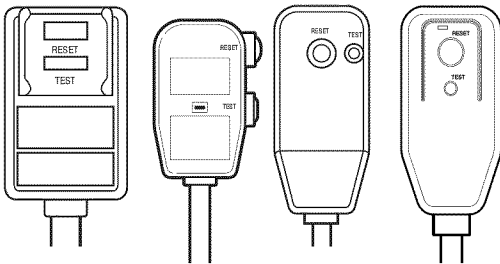

For additional safety, the power cord features an integrated circuit breaker. Test and reset buttons are provided on the plug case.

The circuit breaker should be tested periodically by pressing the TEST button then the RESET button. If the TEST button does not cause the circuit breaker to trip, or if the RESET button will not stay engaged, unplug the air conditioner immediately and contact your LG service technician.

Due to potential safety hazards, the use of an adapter plug is strongly discouraged. For temporary connections, use only a UL-listed adapter. Ensure that the large slot in the adapter is aligned with the large slot in the outlet.

To prevent damage to the adapter's ground terminal, hold the adapter in place while plugging in or unplugging the air conditioner.

- **Attaching the adapter ground terminal to the wall receptacle cover screw does not ground the appliance unless the cover screw is metal and not insulated, and the wall receptacle is grounded through the house wiring.**

PREFERRED GROUNDING METHOD

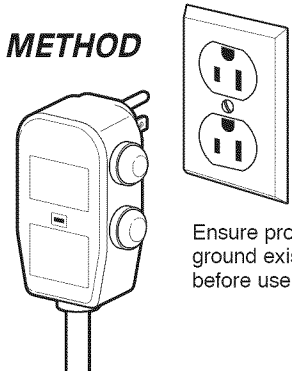

Ensure proper ground exists before use.

TEMPORARY GROUNDING METHOD

(Use of adapter plugs not permitted in Canada)

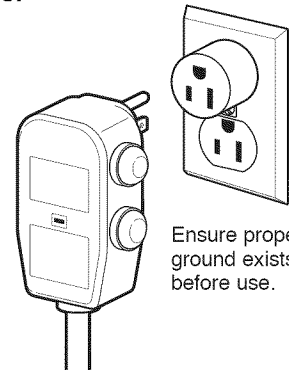

Ensure proper ground exists before use.

- **Frequent connection and disconnection can damage the ground terminal on the adapter. Never use a broken or damaged adapter.**

SAVE THESE INSTRUCTIONS

PARTS AND FEATURES

KEY PARTS AND COMPONENTS

1 CONTROL PANEL AND DISPLAY

Easy-to-read digital display shows the set temperature and indicator lights show the operating mode. Simple push buttons make changing settings quick and easy.

2 MOTORIZED AIR DISCHARGE

The adjustable louvered air discharge opens automatically when the air conditioner is turned on, and closes when it is turned off. It can also be set to oscillate to distribute air more evenly through the room.

3 INFRARED REMOTE CONTROL

The remote control allows you to adjust the temperature and operate most functions of the air conditioner from across the room. A clip is included for convenient storage.

4 HOSE AND DIFFUSER

Use the diffuser and hose to connect the air conditioner to the window installation kit to vent exhaust air outside.

5 FILTER COVER AND FILTER

Filter cover clips in place for easy access to the air filter.

6 INTEGRATED HANDLES

Integrated handles provide a convenient grip when lifting the air conditioner.

7 SWIVELING CASTERS

Swiveling casters allow you to move the air conditioner easily on most floor surfaces.

8 BOTTOM DRAIN PORT

Before moving the unit, drain the internal water collection tank completely by using bottom drain port.

9 MULTI-SPEED FANS

The air conditioner features two multi-speed fans: a circulation fan for moving air inside the room, and an exhaust fan to vent hot air outdoors through the hose and diffuser.

10 POWER SUPPLY CORD HOLDER

Wrap power supply cord around the holders for your convenience.

11 UPPER DRAIN PORT

When FL appears on the display, press AUTO CLEAN button, it will drain out the water collected in internal tank through upper drain port.

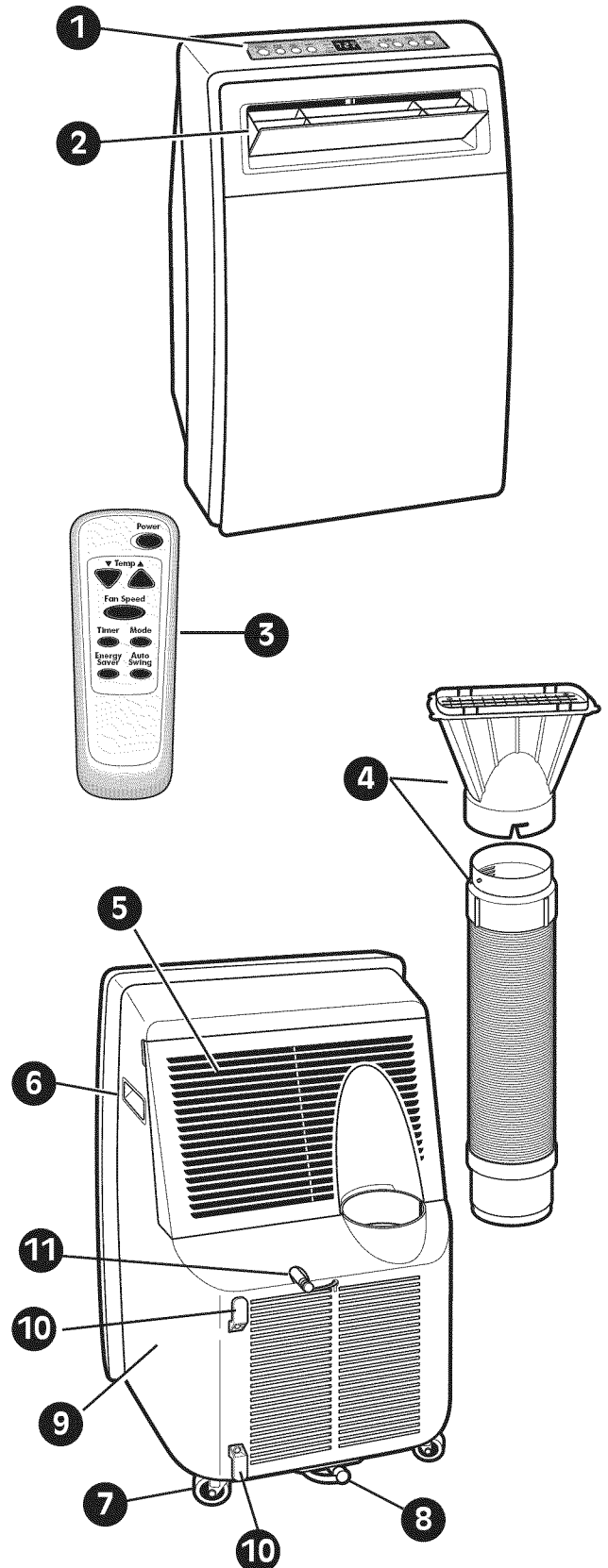

CONTROL PANEL AND REMOTE

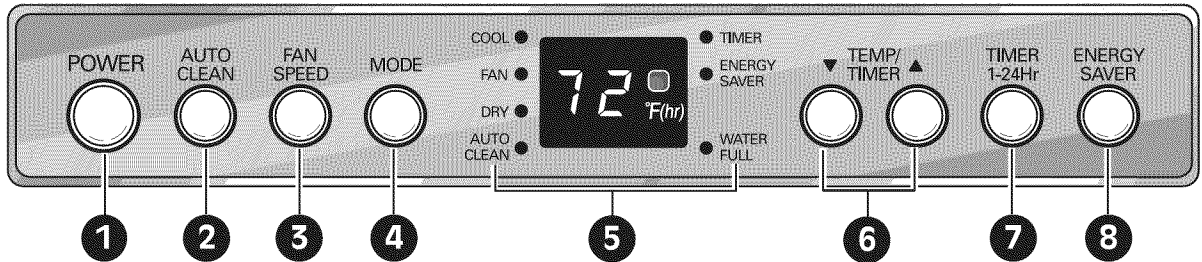

Operation of functions is the same when using the remote or the control panel, unless otherwise stated.

For detailed instructions on each function, see the following pages.

1 POWER ON/OFF

Turns the air conditioner on and off. When turning on, a rising tone will sound to confirm. When turning off, a descending tone will sound.

2 AUTO CLEAN

- The AUTO CLEAN function is used to remove moisture from the heat exchangers and helps prevent odor from forming. This function can be activated from the control panel only.
- When FL appears on the display, press AUTO CLEAN button, it will drain out the water collected in internal tank through upper drain port.

3 FAN SPEED

Adjusts the circulation fan speed between low (F1), medium (F2), and high (F3).

4 MODE

Switches the air conditioner between COOL, FAN, and DRY modes. The respective indicator in the display will light to show the active mode.

5 DIGITAL DISPLAY AND INDICATORS

Digital display shows the set temperature in degrees Fahrenheit, fan speed, or the selected TIMER delay. Indicators will light to show active mode and additional settings. The WATER FULL indicator will light to indicate when the internal water drain tank needs to be emptied.

6 TEMP/TIMER ▲ / ▼

Use these buttons to adjust the set temperature up or down, or to adjust the timer delay time.

7 TIMER 1-24 Hr

Allows you to set a delay from 1 to 24 hours that will turn the air conditioner on or off automatically.

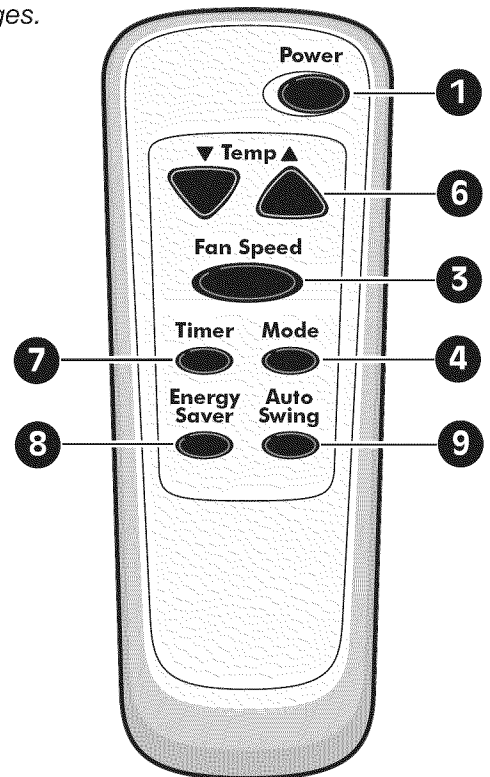

8 ENERGY SAVER

Activates the ENERGY SAVER mode. In this mode, the fans will only run when the compressor is running.

9 AUTO SWING

Sets the motorized air discharge to oscillate, improving air circulation in the room. This function can only be activated from the remote control.

HOW TO USE

BEFORE USING YOUR AIR CONDITIONER

PREPARING FOR OPERATION

Refer to the Installation Instructions included in this manual before using the air conditioner.

Once the air conditioner has been properly assembled and installed:

- 1** Plug the power cord into its own dedicated properly grounded outlet. You will hear a tone to confirm that the conditioner is plugged in. Do not plug other appliances into the same outlet; it could overload the outlet and create a fire hazard.
- 2** Make sure the air conditioner and cord is positioned where it does not create a tripping hazard and will receive adequate ventilation. Do not place it directly next to furniture or objects that could block the vent openings.
- 3** Make sure that any items that could be blown over or damaged by the airflow from the fan are out of the airflow path.

UNPACKING THE AIR CONDITIONER

Remove and store packing materials for reuse.

Remove any shipping tape before using the air conditioner. If the tape leaves behind any adhesive, rub a small amount of liquid dish soap onto it and wipe with a damp cloth. Do NOT use sharp instruments, alcohol, thinners, or abrasive cleaners to remove adhesive. They could damage the finish.

IMPORTANT:

- Do not remain in the direct airflow from the air conditioner for extended periods of time.
- To prevent damage or injury to pets and plants, make sure they are not exposed to direct airflow from the air conditioner.
- When used at the same time as stoves, fireplaces, and other combustion devices, make sure there is a sufficient flow of fresh air into the room. Do **not** use in tightly enclosed spaces with these types of devices.
- This air conditioner is intended for household use as a consumer comfort appliance. Do **not** use it as a precision climate control system, or for purposes such as cooling precision equipment, food, pets, plants, artwork, etc. Such items could be damaged.
- Do not bend the hose downward when window installation kit is not applied. It may cause failure of air conditioner or performance deterioration.

BEFORE USING YOUR AIR CONDITIONER

INSERTING BATTERIES IN THE REMOTE

Before using your remote, install the provided AAA batteries:

- 1 Press in the locking tab on the battery cover on the back of the remote and remove the cover.
- 2 Insert two new alkaline AAA batteries into the battery compartment, being sure to note the proper polarity.
- 3 Reattach the battery cover, making sure the locking tab clicks into place.

NOTES:

- Use only alkaline batteries. Do not use rechargeable batteries.
- When replacing batteries, always replace both batteries with new batteries. Do not mix old and new batteries.
- If the air conditioner will not be used for an extended period of time, remove the batteries from the remote.

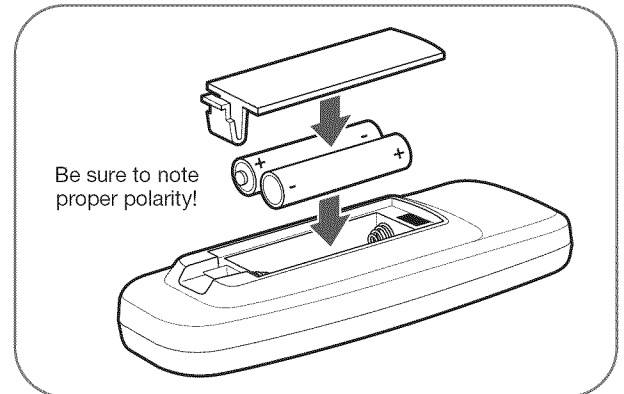

ATTACHING THE REMOTE CLIP

Your air conditioner includes a storage clip for convenient storage of the remote control. Attach it to a wall or to the side of the air conditioner to keep the remote readily at hand.

- 1 Peel off the backing paper from the adhesive tab. Press the holder firmly into place.
- 2 Slide the remote into place for storage.

NOTE:

- If attaching the clip to the air conditioner, attach it only to the side. Do not block the inlets or vents.

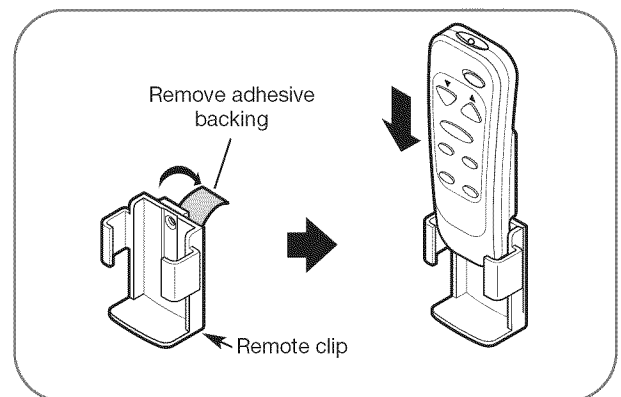

⚠ CAUTION

- If the liquid from the batteries gets onto your skin or clothes, wash it well with clean water. Do not use the remote if the batteries have leaked.
- If you eat the liquid from the batteries, brush your teeth and see doctor. The chemicals in batteries could cause burns or other health hazards.

HOW TO USE

USING THE CONTROLS

Control panel buttons shown. Operation using the remote control is the same, unless specifically noted. **NOTE:** The remote sensor is located next to the display on the control panel.

POWER

Press the **POWER** button to turn the air conditioner ON or OFF. When you turn the air conditioner on, an ascending tone will play and the display will show the set temperature and any special mode setting indicators. The air discharge on the front of the air conditioner will automatically open.

When turning the air conditioner off, you will hear a descending tone and the air discharge on the front of the air conditioner will close.

Any control settings such as Mode, Set Temperature, Auto Swing, etc. will be retained in memory when the power is off.

NOTE: When turned on after being unplugged, the air conditioner will automatically reset to COOL mode, with a temperature setting of 72°F. Any settings will need to be re-entered.

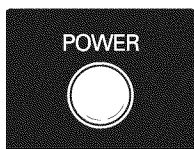

Always point the remote at the sensor. The remote may not work if the sensor is in bright light or if there is not a clear path between the remote and the sensor.

MODE

Press the **MODE** button to select the operating mode (COOL, FAN, or DRY) for the air conditioner. The indicator lamp next to the selected mode will light.

The default setting is COOL. Press the **MODE** button to change to FAN, press again to change to DRY, and again to return to COOL.

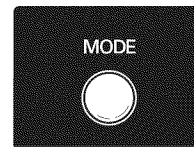

Mode	Features
COOL	Compressor runs and cools the room. Use the TEMP/TIMER ▲ / ▼ and FAN buttons to set the desired temperature and circulation fan speed.
FAN	Fan circulates air but compressor does not run. Use the FAN button to set the desired fan speed.
DRY	Dry mode is used to remove humidity from the room without additional cooling. Once the set temperature is reached, the compressor and circulation fan turns off and only the exhaust fan will run. Fan speed is pre-set and cannot be adjusted.

USING THE CONTROLS

FAN SPEED

Pressing the **FAN SPEED** button cycles the circulation fan speed from low (F1) to medium (F2) to high (F3). The selected fan speed will be shown in the display. The function can be used in either COOL or FAN modes. When changing fan speeds, there is a brief delay before the fan motor changes speed.

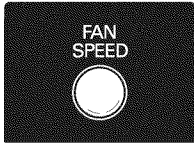

TEMP/TIMER ▲ / ▼

In COOL and DRY modes, the **TEMP/TIMER ▲ / ▼** buttons adjust the set temperature up to 86°F or down to 60°F, in one degree increments. The temperature is in degrees Fahrenheit. It can NOT be switched to degrees Celsius.

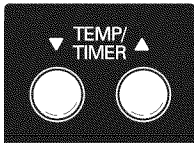

When the **TIMER** function is selected, use the **TEMP/TIMER ▲ / ▼** buttons to adjust the delay time from 1 to 24 hours, in one hour increments.

If you press and hold the **TEMP/TIMER ▲ / ▼** buttons, the set temperature or time will change automatically after a few seconds.

NOTE: The displayed temperature is the SET temperature, **not** the room temperature. In COOL or DRY mode, the thermostat in the air conditioner will run the compressor until the set temperature is reached, then cycle the compressor on and off to maintain the set temperature.

TIMER 1-24 Hr

When the **TIMER** function is selected, you can set the air conditioner to either automatically turn OFF or turn ON after a delay of up to 24 hours. The display will show **0**. Use the **TEMP/TIMER ▲ / ▼** buttons to adjust the delay time from 1 to 24 hours, in one hour increments.

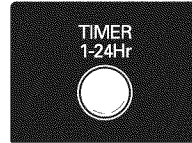

To set an automatic off delay, press the **TIMER** button while the air conditioner is running and use the **TEMP/TIMER ▲ / ▼** buttons to adjust the delay time. The timer indicator will light. The air conditioner will automatically turn OFF after the set delay.

To set an automatic on delay, press the **TIMER** button while the air conditioner is off and use the **TEMP/TIMER ▲ / ▼** buttons to adjust the delay time. The timer indicator will light and the display will show the number of hours remaining until the unit is set to come on. The air conditioner will automatically turn ON after the set delay.

To cancel the Timer function, set the display to "0". If you press and hold the **TEMP/TIMER ▲ / ▼** buttons.

NOTE: Do not unplug the air conditioner when using the timer function.

HOW TO USE

USING THE CONTROLS

ENERGY SAVER

Under normal operation, the exhaust fan cycles on and off with the compressor, and the circulation fan runs at the set speed.



The **ENERGY SAVER** mode helps reduce power consumption by automatically turning off the circulation fan as well as the exhaust fan when the compressor is off. The air conditioner will automatically cycle both fans on and off with the compressor as needed for cooling.

AUTO CLEAN

- To turn the **AUTO CLEAN** function on, press the **AUTO CLEAN** button while the air conditioner is running in COOL or DRY mode. This function can only be selected from the control panel; it is not available from the remote. It must be set each time you wish to run the **AUTO CLEAN** function.



AUTO CLEAN is used to remove moisture from the heat exchange coils. This helps prevent the formation of mildew and odors.

- 1 To use **AUTO CLEAN**:
With the air conditioner running in COOL or DRY mode, press the **AUTO CLEAN** button.
- 2 The indicator will light.
Press the POWER button to turn the air conditioner off. **AUTO CLEAN** will run the circulation and exhaust fans with the compressor off for a few minutes after the power is turned off.

To cancel **AUTO CLEAN**, or to stop an **AUTO CLEAN** cycle in process, simply press the **AUTO CLEAN** button again. The **AUTO CLEAN** function will not operate if the air conditioner is already off.

- When FL appears on the display, press AUTO CLEAN button, it will drain out the water collected in internal tank through upper drain port. See the Care and Cleaning section.

AUTO SWING

AUTO SWING function can only be activated with the remote. When this function is on, the air discharge will oscillate to circulate air more evenly through the room. To turn this function off, simply press the **AUTO SWING** button with the remote again. This setting will stay in memory, even if the power is turned off.

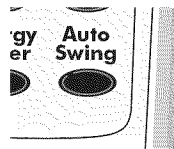

With **AUTO SWING** off, you may also manually adjust the air discharge to the desired position. It will maintain this position until the air conditioner is turned off or **AUTO SWING** is activated.

INSTALLATION INSTRUCTIONS

PREPARING FOR INSTALLATION

⚠️ WARNING The air conditioner is heavy! Use two or more people to lift and install the unit! Failure to do so could result in back injury or other injuries.

EXHAUST COMPONENTS

The following components are used for window venting.
Not all components are used for every installation.

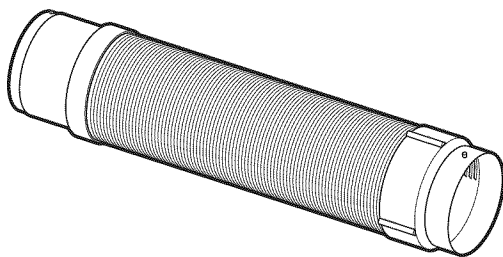

Flexible Venting Hose

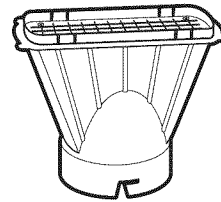

Diffuser

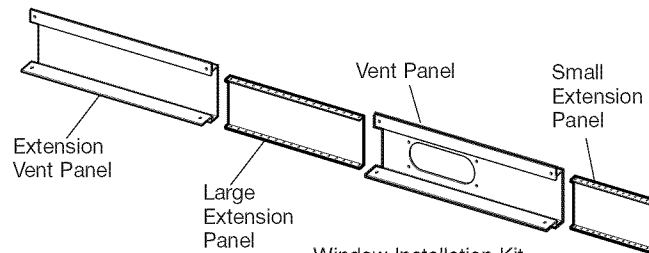

Extension Vent Panel

Large Extension Panel

Vent Panel

Small Extension Panel

Window Installation Kit
(includes 2 Window Vent Panel and 2 Extension Panels)

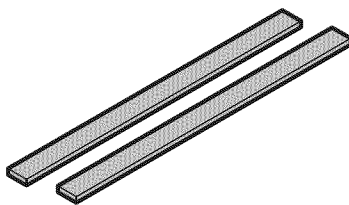

2 Type A Foam Seals
(adhesive)

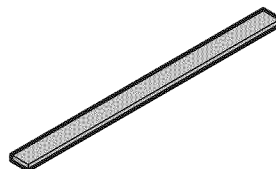

1 Type B Foam Seal
(non-adhesive)

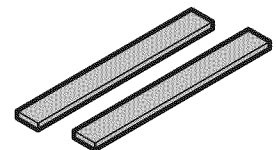

2 Type C Foam Seals
(Adhesive type-Shorter)

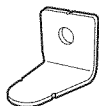

Security Bracket



4 Type A Screws

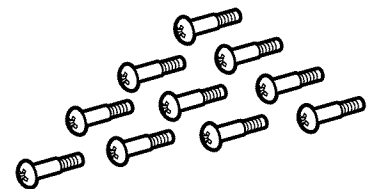

10 Type B Screws



INSTALLATION INSTRUCTIONS

ATTACHING THE HOSE AND DIFFUSER

NOTE: The air conditioner is shipped with the hose installed. The hose may be removed for cleaning and storage, if necessary. Simply reverse the steps below to remove.

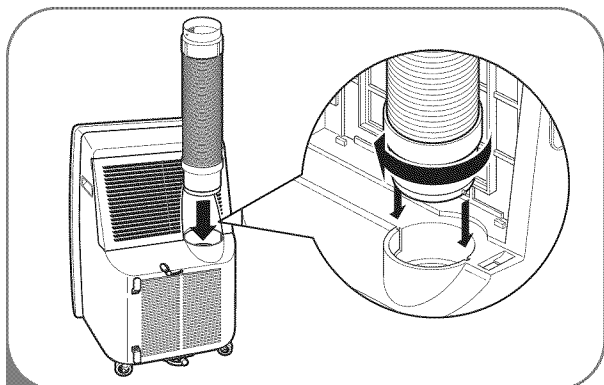

- 1 Insert the large adapter end of the hose into the hole on the back of the air conditioner. Align the pins on the connector with the slots in the hole. Twist slightly clockwise until it locks into place.

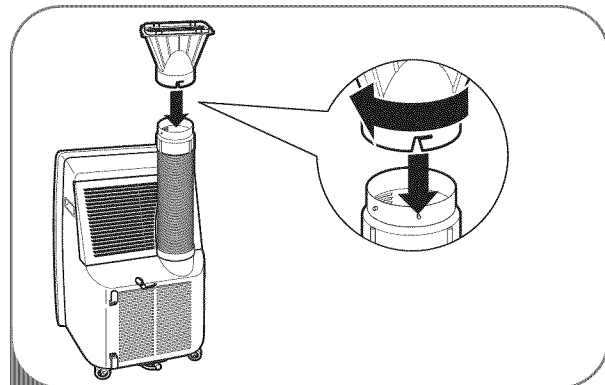

- 2 Fit the round end of the diffuser over the small adapter end of the hose. Align the slots on the diffuser with the pins on the hose. Twist slightly clockwise to lock into place.

INSTALLATION INSTRUCTIONS

WINDOW VENT PANEL AND EXTENSIONS

The window installation kit allows you to install the air conditioner in most vertical-sliding windows 18" to 48" wide, or casement-style windows from 18" to 48" high.

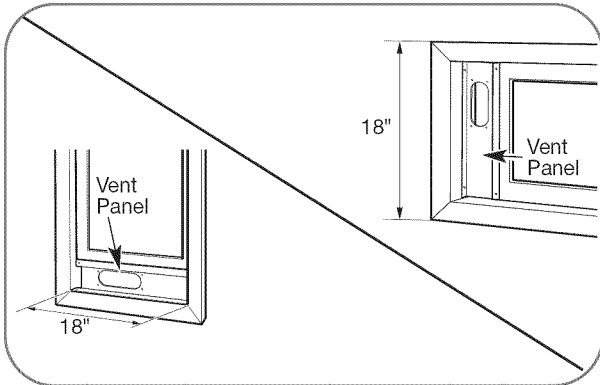

For an 18" window opening, use the window vent panel by itself.

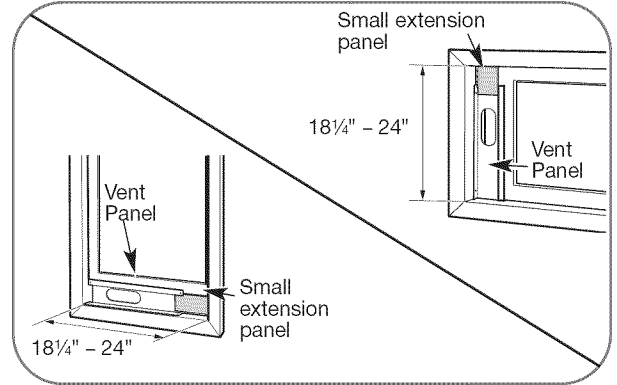

For window openings from 18 $\frac{1}{4}$ " to 24", use the window vent panel and the small extension panel.

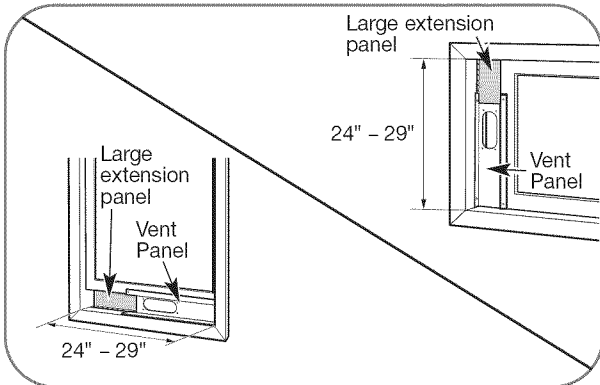

For window openings from 24" to 29", use the window vent panel and the large extension panel.

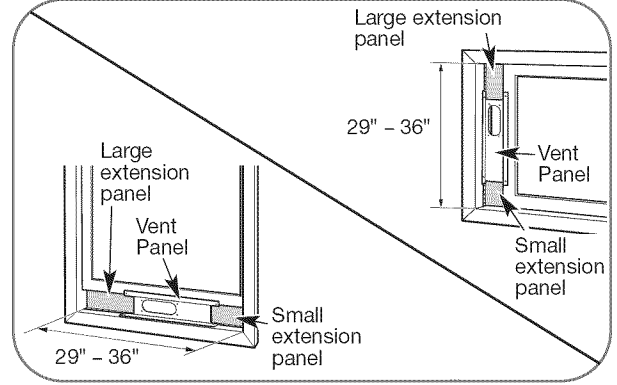

For window openings from 29" to 36", use the window vent panel and both extension panels.

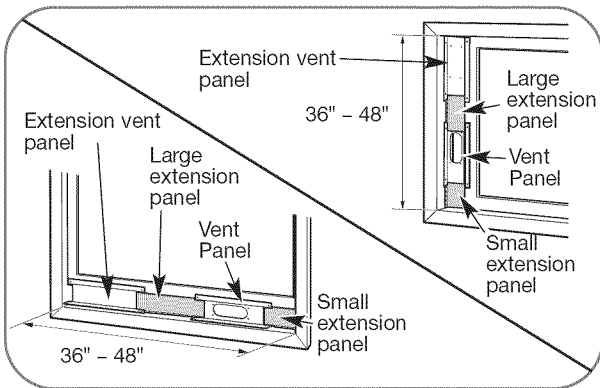

For window openings from 36" to 48", use both vent panels and both extension panels.



INSTALLATION INSTRUCTIONS

INSTALLATION IN VERTICAL SLIDING WINDOWS

NOTE: The window installation kit can be used with vertical sliding windows between 18" and 48" wide.

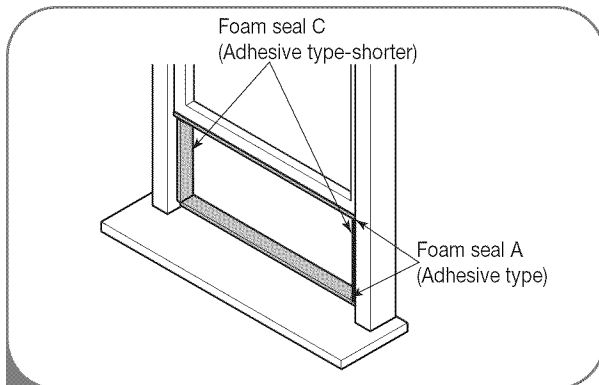

- 1** Cut the foam seal A(adhesive type) & C(adhesive type-shorter) to the proper length, and attach it to the window sash and frame.

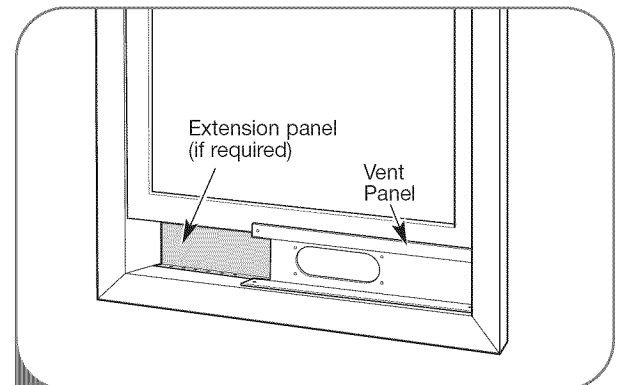

- 2** Insert the vent panel assembly, including extension panels, if needed, into the window opening. Extend the extension panels, if used.

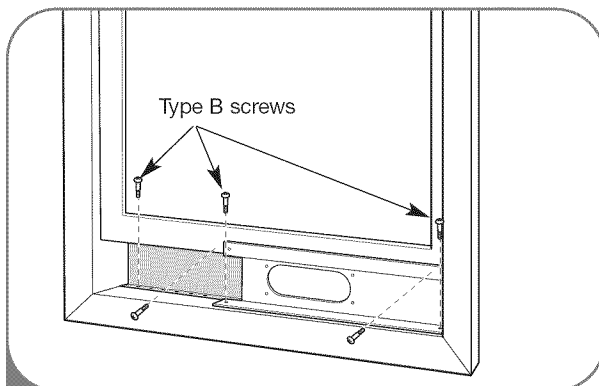

- 3** Carefully lower the window. Secure the vent panel in place with 4 type B screws, plus one screw for each extension:

Vent panel only: 4 type B screws

Vent panel and one extension: 5 type B screws

Vent panel and two extensions: 6 type B screws

Two vent panels and two extensions: 9 type B screws

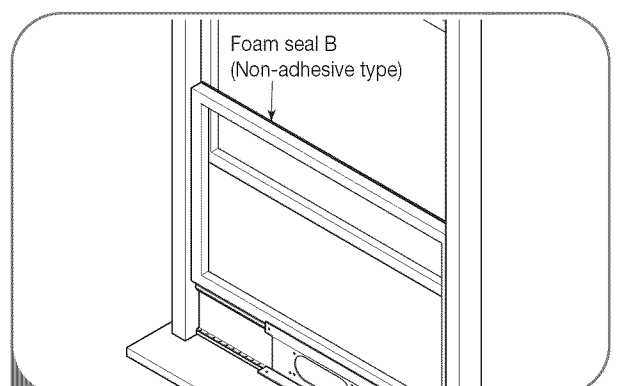

- 4** Cut the foam seal B(Non-adhesive type) to the window width. Stuff the foam seal B between the glass and the window to prevent air and insects from getting into the room.

INSTALLATION INSTRUCTIONS

INSTALLATION IN VERTICAL SLIDING WINDOWS

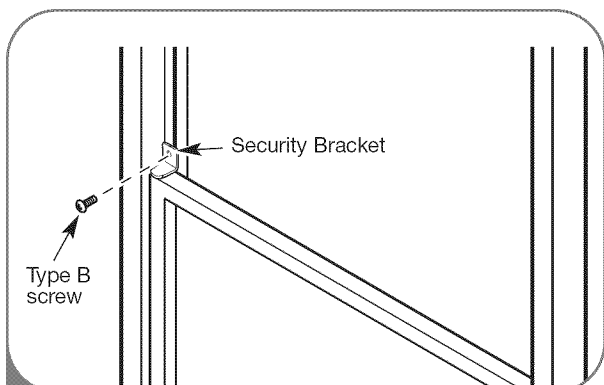

- 5** Install the security bracket with a type B screw, as shown.

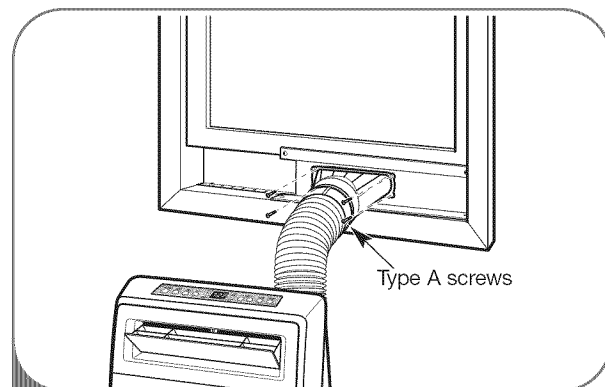

- 6** Insert the oval end of the diffuser into the window installation kit until the locking tabs engage. Secure in place with four Type A screws.



INSTALLATION INSTRUCTIONS

INSTALLATION IN CASEMENT STYLE WINDOWS

NOTE: The window installation kit can be used with casement windows between 18" and 48" tall.

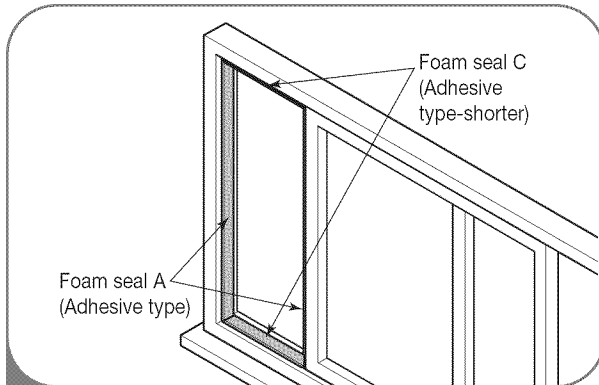

1 Cut the foam seal A(adhesive type) & C(adhesive type-shorter) to the proper length, and attach it to the window sash and frame.

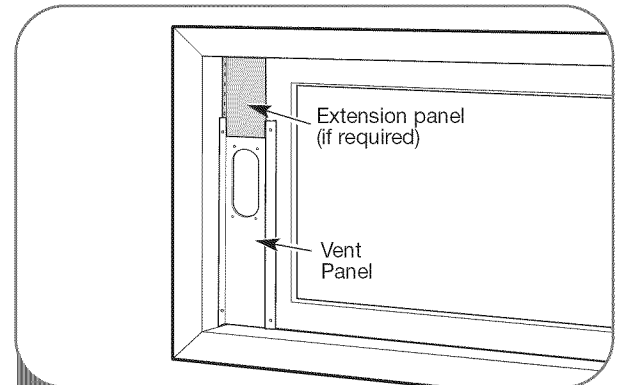

2 Insert the vent panel assembly, including extension panels, if needed, into the window opening. Extend the extension panels, if used.

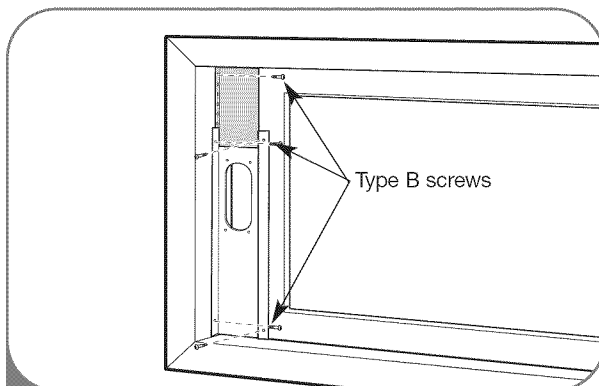

3 Carefully close the window. Secure the vent panel in place with 4 type B screws, plus one screw for each extension:

Vent panel only: 4 type B screws

Vent panel and one extension: 5 type B screws

Vent panel and two extensions: 6 type B screws

Two vent panels and two extensions: 9 type B screws

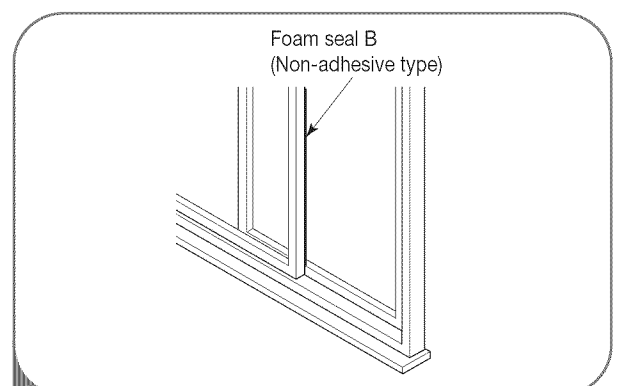

4 Cut the foam seal B(Non-adhesive type) to the window height. Stuff the foam seal B between the glass and the window to prevent air and insects from getting into the room.

INSTALLATION INSTRUCTIONS

INSTALLATION IN CASEMENT STYLE WINDOWS

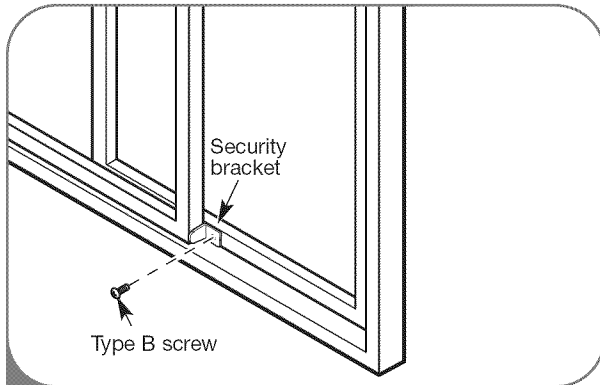

- 5** Install the window security bracket with a type B screw, as shown.

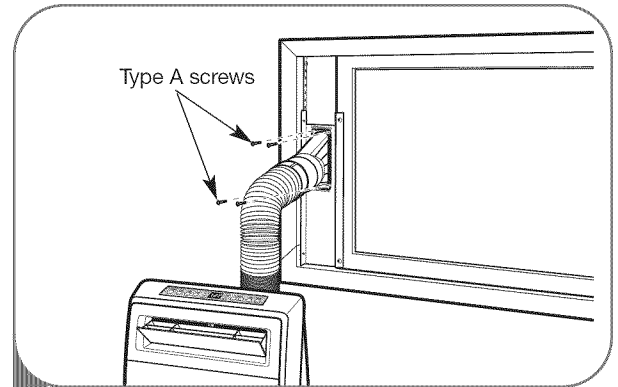

- 6** Insert the oval end of the diffuser into the window installation kit until the locking tabs engage. Secure in place with four of the included screws.

CARE AND CLEANING

Your air conditioner is designed for year-round operation with only minimal cleaning and maintenance.

For maximum efficiency, it is recommended that you have the cooling coils inspected and cleaned annually. Your local LG Authorized Service Center can provide this inspection and cleaning service for a nominal fee.

WARNING

- Unplug the air conditioner before cleaning or performing any maintenance or servicing.
- Be careful when cleaning coils or removing or reinstalling the filter—the cooling fins are sharp!

Failure to follow the above precautions could result in electrical shock or personal injury.

CLEANING THE CASE

Wipe the case with a slightly damp cloth, then wipe dry with a dry cloth or towel.

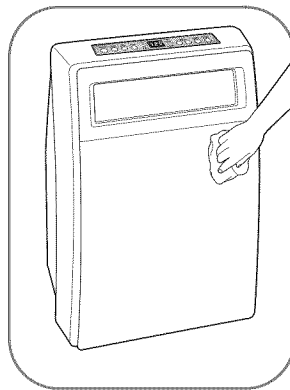

- To prevent damage to the finish, do not use gasoline, benzene, thinner, etc., or any abrasive cleansers to clean the air conditioner; they may damage the finish.
- Never pour water onto or into the unit; it could damage internal components and create a shock and fire hazard.

CLEANING THE AIR FILTER

The air filter should be cleaned every two weeks; depending on indoor air quality, more frequent cleaning may be needed. A dirty air filter will decrease airflow and reduce efficiency.

Do not operate the air conditioner without the air filter in place.

- 1 Grasp the two grips on the filter cover panel and pull back to open the cover.
- 2 Lift out the air filter by the handle.

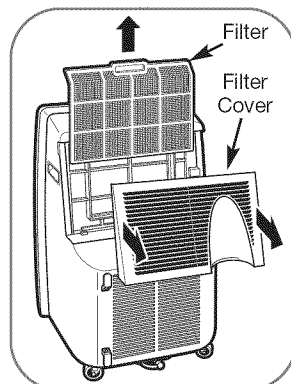

- 3 Use a vacuum cleaner to clean the filter. If the filter is heavily soiled, it can be washed in warm water using a mild detergent. **Do not use harsh cleaners or very hot water. Do not wash in a dishwasher.**
- 4 Allow the filter to dry completely before reinstalling.
- 5 Reinsert the filter, making sure that the bottom of the filter is between the tabs and the coil guard. Reinstall the filter cover, making sure it clips into place.

EMPTYING THE WATER COLLECTION TANK

Using the bottom drain port

When the internal water collection tank is full, **FL** will appear in the display and the air conditioner will turn off until the tank is emptied.

- 1 Unplug the air conditioner, disconnect the exhaust hose from the back, and move the air conditioner to a suitable drain location or outdoors. You may also place a pan under the drain that will hold up to 1 quart of water.
- 2 Remove the drain cap from the drain outlet.
- 3 Once the water collection tank is drained, reinstall the drain cap, making sure it is on securely.
- 4 Place the air conditioner in the desired location, reconnect the exhaust hose, and plug in the air conditioner.

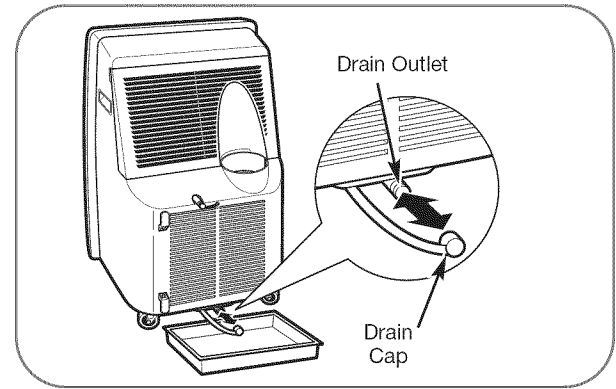

Using the upper drain port

When the internal water collection tank is full, **FL** will appear in the display and the air conditioner will turn off until the tank is emptied.

- 1 Place a suitable bucket under the upper drain port.
- 2 Remove the drain cap.
- 3 Press the Auto Clean button.
- 4 Wait till water is drained out completely.
- 5 Replace the cap, make sure it is on securely.
- 6 Reset your settings.

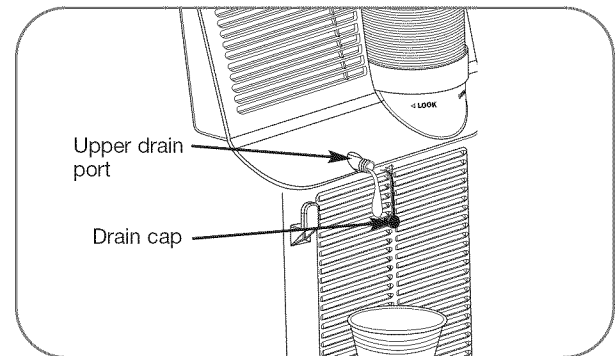

NOTES:

- When turned on after being unplugged, the air conditioner will automatically reset to COOL mode, with a temperature setting of 72°F.
- The air conditioner features a drain pump for increased operating efficiency.
- Make sure to use a bucket with a minimum capacity of 0.5 gallon.

CARE AND CLEANING

STORING THE AIR CONDITIONER

If the air conditioner will not be used for an extended period of time:

- 1 Drain the water collection tank completely and leave the bottom drain cap off long enough to allow any residual water to drain out. Once the tank is completely drained and no more water flows out, reinstall the cap.
- 2 Remove and clean the filter, allow it to dry completely, then reinstall it.
- 3 Remove the batteries from the remote.
- 4 Store the air conditioner in a cool, dry location, away from direct sunlight, extreme temperatures, and excessive dust.

Before using the air conditioner again:

- 1 Make sure the filter and drain cap are in place.
- 2 Check the cord to make sure it is in good condition, with no cracks or damage.
- 3 Place new batteries in the remote.
- 4 Install the air conditioner as described in the Installation Instructions.

TROUBLESHOOTING

BEFORE CALLING FOR SERVICE

Before you call for service, review this list. It may save you time and expense. This list includes common occurrences that are not the result of a defect in workmanship or materials.

Problem	Possible Causes	Solutions
Air conditioner will not start	<ul style="list-style-type: none"> • The air conditioner plug is not completely inserted in the electrical outlet. • The house fuse is blown or the circuit breaker has tripped. • Power failure. • The integrated circuit breaker in the plug has tripped. • FL appears in the display. • Room temperature is less than the set temperature. 	<ul style="list-style-type: none"> • Make sure electrical plug is plugged completely into a live, properly grounded outlet. • Replace the fuse or reset the circuit breaker. Make sure that there are no other appliances on the same circuit. • If a power failure occurs, turn the power OFF. When power is restored, wait 3 minutes before restarting the air conditioner. • Press the RESET button on the air conditioner plug. If the reset button will not stay engaged, unplug the air conditioner and contact a qualified service technician. • The water collection tank is full. Drain the tank and reset your settings. See the Care and Cleaning section. • This is normal. The air conditioner automatically shuts off when the room equals or is less than the set temperature. Adjust the temperature setting, if needed.
Air conditioner does not cool properly	<ul style="list-style-type: none"> • Airflow is restricted. • The air filter is dirty. • The room is very hot, or not enough time allowed for cooling. • Cold air is escaping. • Cooling coils have iced up. 	<ul style="list-style-type: none"> • Make sure there is sufficient clearance around the air conditioner and that the air inlet and outlet are not blocked by furniture, curtains, etc. • Clean the air filter at least every two weeks. See the <i>Care and Cleaning</i> section. • When first turned on, allow the air conditioner sufficient time to cool the room. • Check for open furnace floor registers or cold air returns, or open windows or doors. • In especially hot, humid weather and when the air conditioner is running frequently or for extended periods, ice can form on the cooling coils, blocking air flow. Set the controls to High Fan (F3) or High Cool (F3), and set to a warmer temperature.
Air conditioner runs too often or too long	<ul style="list-style-type: none"> • Area to be cooled is too large for the air conditioner. • Doors or windows are open. 	<ul style="list-style-type: none"> • Consult your dealer for the air conditioner capacity necessary to cool the desired area. • Make sure doors and windows are closed.



TROUBLESHOOTING

BEFORE CALLING FOR SERVICE

Problem	Possible Causes	Solutions
Code appears in the display: <i>F1, F2, or F3</i>	<ul style="list-style-type: none">• Air conditioner is in FAN mode and the number shown is the set fan speed.	<ul style="list-style-type: none">• This is normal. The air conditioner is working properly.
<i>FL</i>	<ul style="list-style-type: none">• The water collection tank is full.	<ul style="list-style-type: none">• Empty the water collection tank. See the <i>Care and Cleaning</i> section.
<i>CH01</i>	<ul style="list-style-type: none">• Short or open circuit in the indoor air thermostat.	<ul style="list-style-type: none">• Unplug the air conditioner and contact your authorized LG service center.

LG ELECTRONICS, INC.

PORTABLE AIR CONDITIONER LIMITED WARRANTY — USA



Should your LG Portable Air Conditioner prove to be defective in material or workmanship under normal use during the warranty period listed below, effective from the date of original consumer purchase of the product, LG Electronics will replace the defective part(s). Replacement parts will meet intended fit and function of the original part. Replacement parts are warranted for the unexpired portion of the original warranty period. This limited warranty is good only to the original purchaser of the product and effective only when used in the United States of America.

WARRANTY PERIOD:	
For the Period of: One year from date of original purchase	LG Will Replace: Any part of the LGE Portable Air Conditioner which fails due to a defect in materials or workmanship. During this full one-year warranty , LGE will also provide, free of charge , all labor and on-site service to replace the defective part.
Five years from date of original purchase	Any part of the sealed refrigerating system (the compressor, condenser, evaporator, and all connecting tubing) which fails due to a defect in materials or workmanship. During this full five-year sealed refrigerating system warranty , LGE will also provide, free of charge , all labor and on-site service to replace the defective part.
Five years from date of original purchase	For the second through the fifth year from the date of original purchase, LGE will replace certain parts that fail due to a defect in materials or workmanship. Parts covered are fan motors, switches, thermostats, heater, heater protectors, compressor overload, solenoids, circuit boards, auxiliary controls, thermistors, frost controls, ICR pump, capacitors, varistors, and indoor blower bearing. During this limited four-year parts warranty , you will be responsible for any labor or on-site service costs.

No other warranty is applicable to this product. THIS WARRANTY IS IN LIEU OF ANY OTHER WARRANTY, EXPRESS OR IMPLIED, INCLUDING WITHOUT LIMITATION, ANY WARRANTY OF MERCHANTABILITY OR FITNESS FOR A PARTICULAR PURPOSE. TO THE EXTENT ANY IMPLIED WARRANTY IS REQUIRED BY LAW, IT IS LIMITED IN DURATION TO THE EXPRESS WARRANTY PERIOD ABOVE. NEITHER THE MANUFACTURER NOR ITS U.S. DISTRIBUTOR SHALL BE LIABLE FOR ANY INCIDENTAL, CONSEQUENTIAL, INDIRECT, SPECIAL, OR PUNITIVE DAMAGES OF ANY NATURE, INCLUDING WITHOUT LIMITATION, LOST REVENUES OR PROFITS, OR ANY OTHER DAMAGE WHETHER BASED IN CONTRACT, TORT, OR OTHERWISE. Some states and/or territories do not allow the exclusion or limitation of incidental or consequential damages or limitations on how long an implied warranty lasts, so the above exclusion or limitation may not apply to you. This warranty gives you, the original purchaser, specific legal rights and you may also have other rights that vary from state to state or territory to territory.

THIS LIMITED WARRANTY DOES NOT APPLY TO:

1. Service calls to your home for delivery or pick-up, installation, instruction, replacement of house fuses, connection of house wiring or plumbing, or to correct unauthorized repairs.
 2. Failure of product to perform during power failures and interruptions or inadequate electrical service.
 3. Damage caused by transportation or handling.
 4. Damage caused to the product by accident, vermin, lightning, winds, fire, floods, or acts of God.
 5. Damages caused by leaky or broken water pipes, frozen water pipes, restricted drain lines, or inadequate or interrupted water supply.
 6. Damages caused by inadequate supply of air.
 7. Damages caused by operating the product in a corrosive atmosphere.
 8. Repairs when your LG product is used in other than normal, single-family household use or contrary to the instructions described in the product User's Guide.
 9. Damage resulting from accident, alteration, misuse, abuse, or improper installation, repair, or maintenance. Improper repair includes the use of parts not approved or specified by LG.
 10. Normal maintenance as described in the User's Guide, such as cleaning or replacing filters, cleaning coils, etc.
 11. Use of accessories or components that are not compatible with this product.
 12. Products with altered or removed serial numbers.
 13. Changes in the appearance of the product that do not affect product performance.
 14. Increases in utility costs and additional utility expenses.
- The cost of repair or replacement under these excluded circumstances shall be borne by the consumer.**

TO CONTACT LG ELECTRONICS BY MAIL:

LG Customer Interactive Center
 P. O. Box 240007
 201 James Record Road
 Huntsville, Alabama 35824
 ATTN: CIC

Product Registration Information

Model Number: _____

Serial Number: _____

You can find these numbers on a label on the side of the air conditioner.

Date of Purchase: _____

Dealer's Name: _____

