

# OPERATOR'S MANUAL

# CRAFTSMAN<sup>®</sup>

## 3 in. x 21 in. BELT SANDER VARIABLE SPEED DOUBLE INSULATED

Model No.  
315.117271

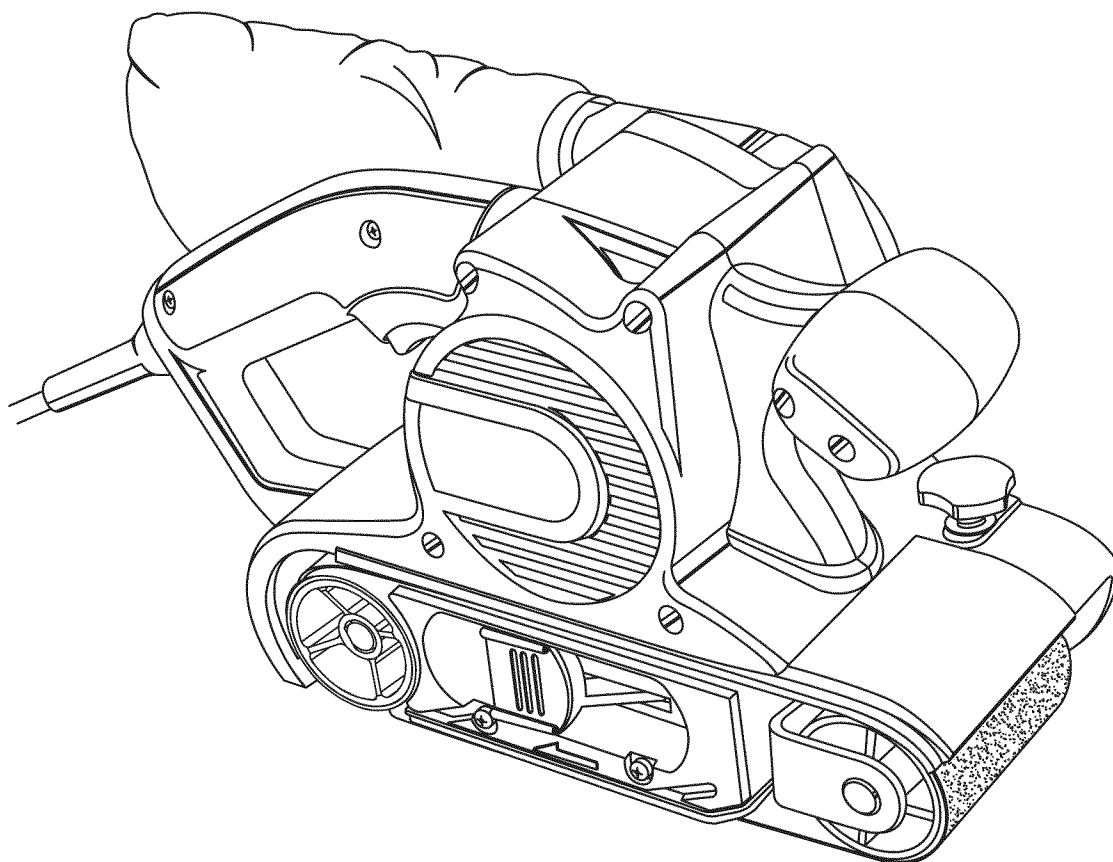

**⚠ WARNING:** To reduce the risk of injury, the user must read and understand the operator's manual before using this product.

Customer Help Line: 1-800-932-3188

Sears, Roebuck and Co., 3333 Beverly Rd., Hoffman Estates, IL 60179 USA  
Visit the Craftsman web page: [www.sears.com/craftsman](http://www.sears.com/craftsman)

983000-752  
5-05

**Save this manual for future reference**



# TABLE OF CONTENTS

■ Warranty .....	2
■ Introduction .....	2
■ General Safety Rules .....	3-4
■ Specific Safety Rules.....	4
■ Symbols.....	5-6
■ Electrical .....	7
■ Features.....	8-9
■ Assembly .....	9
■ Operation.....	10-14
■ Maintenance.....	14
■ Exploded View and Parts List.....	15-16
■ Parts Ordering/Service .....	Back Page

## WARRANTY

### ONE YEAR FULL WARRANTY ON CRAFTSMAN TOOL

If this Craftsman tool fails to give complete satisfaction within one year from date of purchase, **RETURN IT TO THE NEAREST SEARS STORE OR SEARS PARTS & REPAIR CENTER IN THE UNITED STATES**, and Sears will repair it, free of charge.

If this Craftsman tool is used for commercial or rental purposes, this warranty applies for only 90 days from the date of purchase.

This warranty gives you specific legal rights, and you may also have other rights which vary from state to state.

**Sears, Roebuck and Co., Dept. 817WA, Hoffman Estates, IL 60179**

## INTRODUCTION

This tool has many features for making its use more pleasant and enjoyable. Safety, performance, and dependability have been given top priority in the design of this product making it easy to maintain and operate.

# GENERAL SAFETY RULES

**⚠ WARNING:** Read and understand all instructions. Failure to follow all instructions listed below, may result in electric shock, fire and/or serious personal injury.

## SAVE THESE INSTRUCTIONS

### WORK AREA

- **Keep your work area clean and well lit.** Cluttered benches and dark areas invite accidents.
- **Do not operate power tools in explosive atmospheres, such as in the presence of flammable liquids, gases, or dust.** Power tools create sparks which may ignite the dust or fumes.
- **Keep bystanders, children, and visitors away while operating a power tool.** Distractions can cause you to lose control.

### ELECTRICAL SAFETY

- **Double insulated tools are equipped with a polarized plug (one blade is wider than the other). This plug will fit in a polarized outlet only one way. If the plug does not fit fully in the outlet, reverse the plug. If it still does not fit, contact a qualified electrician to install a polarized outlet. Do not change the plug in any way.** Double insulation  eliminates the need for the three-wire grounded power cord and grounded power supply system.
- **Avoid body contact with grounded surfaces such as pipes, radiators, ranges, and refrigerators.** There is an increased risk of electric shock if your body is grounded.
- **Don't expose power tools to rain or wet conditions.** Water entering a power tool will increase the risk of electric shock.
- **Do not abuse the cord. Never use the cord to carry the tools or pull the plug from an outlet. Keep cord away from heat, oil, sharp edges, or moving parts. Replace damaged cords immediately.** Damaged cords increase the risk of electric shock.
- **When operating a power tool outside, use an outdoor extension cord marked "W-A" or "W".** These cords are rated for outdoor use and reduce the risk of electric shock.

### PERSONAL SAFETY

- **Stay alert, watch what you are doing and use common sense when operating a power tool. Do not use tool while tired or under the influence of drugs, alcohol, or medication.** A moment of inattention while operating power tools may result in serious personal injury.
- **Dress properly. Do not wear loose clothing or jewelry. Contain long hair. Keep your hair, clothing, and gloves away from moving parts.** Loose clothes, jewelry, or long hair can be caught in moving parts.

- **Avoid accidental starting. Be sure switch is off before plugging in.** Carrying tools with your finger on the switch or plugging in tools that have the switch on invites accidents.
- **Remove adjusting keys or wrenches before turning the tool on.** A wrench or a key that is left attached to a rotating part of the tool may result in personal injury.
- **Do not overreach. Keep proper footing and balance at all times.** Proper footing and balance enables better control of the tool in unexpected situations.
- **Use safety equipment. Always wear eye protection.** Dust mask, nonskid safety shoes, hard hat, or hearing protection must be used for appropriate conditions.
- **Do not wear loose clothing or jewelry. Contain long hair.** Loose clothes, jewelry, or long hair can be drawn into air vents.
- **Do not use on a ladder or unstable support.** Stable footing on a solid surface enables better control of the tool in unexpected situations.

### TOOL USE AND CARE

- **Use clamps or other practical way to secure and support the workpiece to a stable platform.** Holding the work by hand or against your body is unstable and may lead to loss of control.
- **Do not force tool. Use the correct tool for your application.** The correct tool will do the job better and safer at the rate for which it is designed.
- **Do not use tool if switch does not turn it on or off.** Any tool that cannot be controlled with the switch is dangerous and must be repaired.
- **Disconnect the plug from power source before making any adjustments, changing accessories, or storing the tool.** Such preventive safety measures reduce the risk of starting the tool accidentally.
- **Store idle tools out of the reach of children and other untrained persons.** Tools are dangerous in the hands of untrained users.
- **Maintain tools with care. Keep cutting tools sharp and clean.** Properly maintained tools with sharp cutting edges are less likely to bind and are easier to control.
- **Check for misalignment or binding of moving parts, breakage of parts, and any other condition that may affect the tool's operation. If damaged, have the tool serviced before using.** Many accidents are caused by poorly maintained tools.
- **Use only accessories that are recommended by the manufacturer for your model.** Accessories that may be suitable for one tool, may become hazardous when used on another tool.
- **Keep the tool and its handle dry, clean and free from oil and grease.** Always use a clean cloth when cleaning. Never use brake fluids, gasoline, petroleum-based products, or any strong solvents to clean your tool. Following this rule will reduce the risk of loss of control and deterioration of the enclosure plastic.

# GENERAL SAFETY RULES

## SERVICE

- **Tool service must be performed only by qualified repair personnel.** Service or maintenance performed by unqualified personnel may result in a risk of injury.
- **When servicing a tool, use only identical replacement parts.** Follow instructions in the Maintenance section of this manual. Use of unauthorized parts or failure to follow Maintenance Instructions may create a risk of shock or injury.

# SPECIFIC SAFETY RULES

- **Hold tool by insulated gripping surfaces when performing an operation where the cutting tool may contact hidden wiring or its own cord.** Contact with a “live” wire will make exposed metal parts of the cutting tool “live” and shock the operator.
- **Know your power tool. Read operator’s manual carefully. Learn its applications and limitations, as well as the specific potential hazards related to this tool.** Following this rule will reduce the risk of electric shock, fire, or serious injury.
- **Always wear safety glasses. Everyday eyeglasses have only impact-resistant lenses; they are NOT safety glasses.** Following this rule will reduce the risk of serious personal injury.
- **Protect your lungs. Wear a face or dust mask if the operation is dusty.** Following this rule will reduce the risk of serious personal injury.
- **Protect your hearing. Wear hearing protection during extended periods of operation.** Following this rule will reduce the risk of serious personal injury.
- **Inspect tool cords periodically and, if damaged, have repaired at your nearest Authorized Service Center. Constantly stay aware of cord location.** Following this rule will reduce the risk of electric shock or fire.
- **Check damaged parts. Before further use of the tool, a guard or other part that is damaged should be carefully checked to determine that it will operate properly and perform its intended function. Check for alignment of moving parts, binding of moving parts, breakage of parts, mounting, and any other conditions that may affect its operation. A guard or other part that is damaged should be properly repaired or replaced by an authorized service center.** Following this rule will reduce the risk of shock, fire, or serious injury.
- **Make sure your extension cord is in good condition. When using an extension cord, be sure to use one heavy enough to carry the current your product will draw. A wire gauge size (A.W.G.) of at least 14 is recommended for an extension cord 50 feet or less in length. A cord exceeding 100 feet is not recommended. If in doubt, use the next heavier gauge. The smaller the gauge number, the heavier the cord.** An undersized cord will cause a drop in line voltage resulting in loss of power and overheating.
- **Inspect for and remove all nails from lumber before using this tool.** Following this rule will reduce the risk of serious personal injury.
- **Save these instructions.** Refer to them frequently and use them to instruct others who may use this tool. If you loan someone this tool, loan them these instructions also.











 **WARNING:** Some dust created by power sanding, sawing, grinding, drilling, and other construction activities contains chemicals known to cause cancer, birth defects or other reproductive harm. Some examples of these chemicals are:

- lead from lead-based paints,
- crystalline silica from bricks and cement and other masonry products, and
- arsenic and chromium from chemically-treated lumber.

Your risk from these exposures varies, depending on how often you do this type of work. To reduce your exposure to these chemicals: work in a well ventilated area, and work with approved safety equipment, such as those dust masks that are specially designed to filter out microscopic particles.



# SYMBOLS

Some of the following symbols may be used on this tool. Please study them and learn their meaning. Proper interpretation of these symbols will allow you to operate the tool better and safer.

SYMBOL	NAME	DESIGNATION/EXPLANATION
V	Volts	Voltage
A	Amperes	Current
Hz	Hertz	Frequency (cycles per second)
W	Watt	Power
min	Minutes	Time
~	Alternating Current	Type of current
==	Direct Current	Type or a characteristic of current
$n_0$	No Load Speed	Rotational speed, at no load
	Class II Construction	Double-insulated construction
.../min	Per Minute	Revolutions, strokes, surface speed, orbits etc., per minute
	Wet Conditions Alert	Do not expose to rain or use in damp locations.
	Read The Operator's Manual	To reduce the risk of injury, user must read and understand operator's manual before using this product.
	Eye Protection	Always wear safety goggles, safety glasses with side shields, or a full face shield when operating this product.
	Safety Alert	Precautions that involve your safety.
	No Hands Symbol	Failure to keep your hands away from the blade will result in serious personal injury.
	No Hands Symbol	Failure to keep your hands away from the blade will result in serious personal injury.
	No Hands Symbol	Failure to keep your hands away from the blade will result in serious personal injury.
	No Hands Symbol	Failure to keep your hands away from the blade will result in serious personal injury.
	Hot Surface	To reduce the risk of injury or damage, avoid contact with any hot surface.

# SYMBOLS

The following signal words and meanings are intended to explain the levels of risk associated with this product.

SYMBOL	SIGNAL	MEANING
	<b>DANGER:</b>	Indicates an imminently hazardous situation, which, if not avoided, will result in death or serious injury.
	<b>WARNING:</b>	Indicates a potentially hazardous situation, which, if not avoided, could result in death or serious injury.
	<b>CAUTION:</b>	Indicates a potentially hazardous situation, which, if not avoided, may result in minor or moderate injury.
	<b>CAUTION:</b>	(Without Safety Alert Symbol) Indicates a situation that may result in property damage.

## SERVICE

Servicing requires extreme care and knowledge and should be performed only by a qualified service technician. For service we suggest you return the product to your nearest **AUTHORIZED SERVICE CENTER** for repair. When servicing, use only identical replacement parts.



**WARNING:** To avoid serious personal injury, do not attempt to use this product until you read thoroughly and understand completely the operator's manual. Save this operator's manual and review frequently for continuing safe operation and instructing others who may use this product.



## WARNING:



The operation of any power tool can result in foreign objects being thrown into your eyes, which can result in severe eye damage. Before beginning power tool operation, always wear safety goggles, safety glasses with side shields, or a full face shield when needed. We recommend Wide Vision Safety Mask for use over eyeglasses or standard safety glasses with side shields. Always use eye protection which is marked to comply with ANSI Z87.1.

## SAVE THESE INSTRUCTIONS

# ELECTRICAL

## DOUBLE INSULATION

Double insulation is a concept in safety in electric power tools, which eliminates the need for the usual three-wire grounded power cord. All exposed metal parts are isolated from the internal metal motor components with protecting insulation. Double insulated tools do not need to be grounded.

 **WARNING:** The double insulated system is intended to protect the user from shock resulting from a break in the tool's internal insulation. Observe all normal safety precautions to avoid electrical shock.

**NOTE:** Servicing of a tool with double insulation requires extreme care and knowledge of the system and should be performed only by a qualified service technician. For service, we suggest you return the tool to your nearest authorized service center for repair. Always use original factory replacement parts when servicing.

## ELECTRICAL CONNECTION

This tool has a precision-built electric motor. It should be connected to a **power supply that is 120 volts, 60 Hz, AC only (normal household current)**. Do not operate this tool on direct current (DC). A substantial voltage drop will cause a loss of power and the motor will overheat. If your tool does not operate when plugged into an outlet, double-check the power supply.

## EXTENSION CORDS

When using a power tool at a considerable distance from a power source, be sure to use an extension cord that has the capacity to handle the current the tool will draw. An undersized cord will cause a drop in line voltage, resulting in overheating and loss of power. Use the chart to determine the minimum wire size required in an extension cord. Only round jacketed cords listed by Underwriter's Laboratories (UL) should be used.

When working outdoors with a tool, use an extension cord that is designed for outside use. This type of cord is designated with "WA" on the cord's jacket.

Before using any extension cord, inspect it for loose or exposed wires and cut or worn insulation.

\*\*Ampere rating (on tool faceplate)  
0-2.0 2.1-3.4 3.5-5.0 5.1-7.0 7.1-12.0 12.1-16.0

Cord Length	Wire Size (A.W.G.)					
25'	16	16	16	16	14	14
50'	16	16	16	14	14	12
100'	16	16	14	12	10	—

\*\*Used on 12 gauge - 20 amp circuit

**NOTE:** AWG = American Wire Gauge

 **WARNING:** Keep the extension cord clear of the working area. Position the cord so that it will not get caught on lumber, tools or other obstructions while you are working with a power tool. Failure to do so can result in serious personal injury.

 **WARNING:** Check extension cords before each use. If damaged replace immediately. Never use tool with a damaged cord since touching the damaged area could cause electrical shock resulting in serious injury.

# FEATURES

## PRODUCT SPECIFICATIONS

Belt Size .....3 in. x 21 in.  
Sanding Surface..... 16.5 sq. in.  
No Load Speed .....800-1,300/min.

Input .....120 V, 60 Hz, AC only, 8.5 Amps  
Net Weight.....11 lbs.

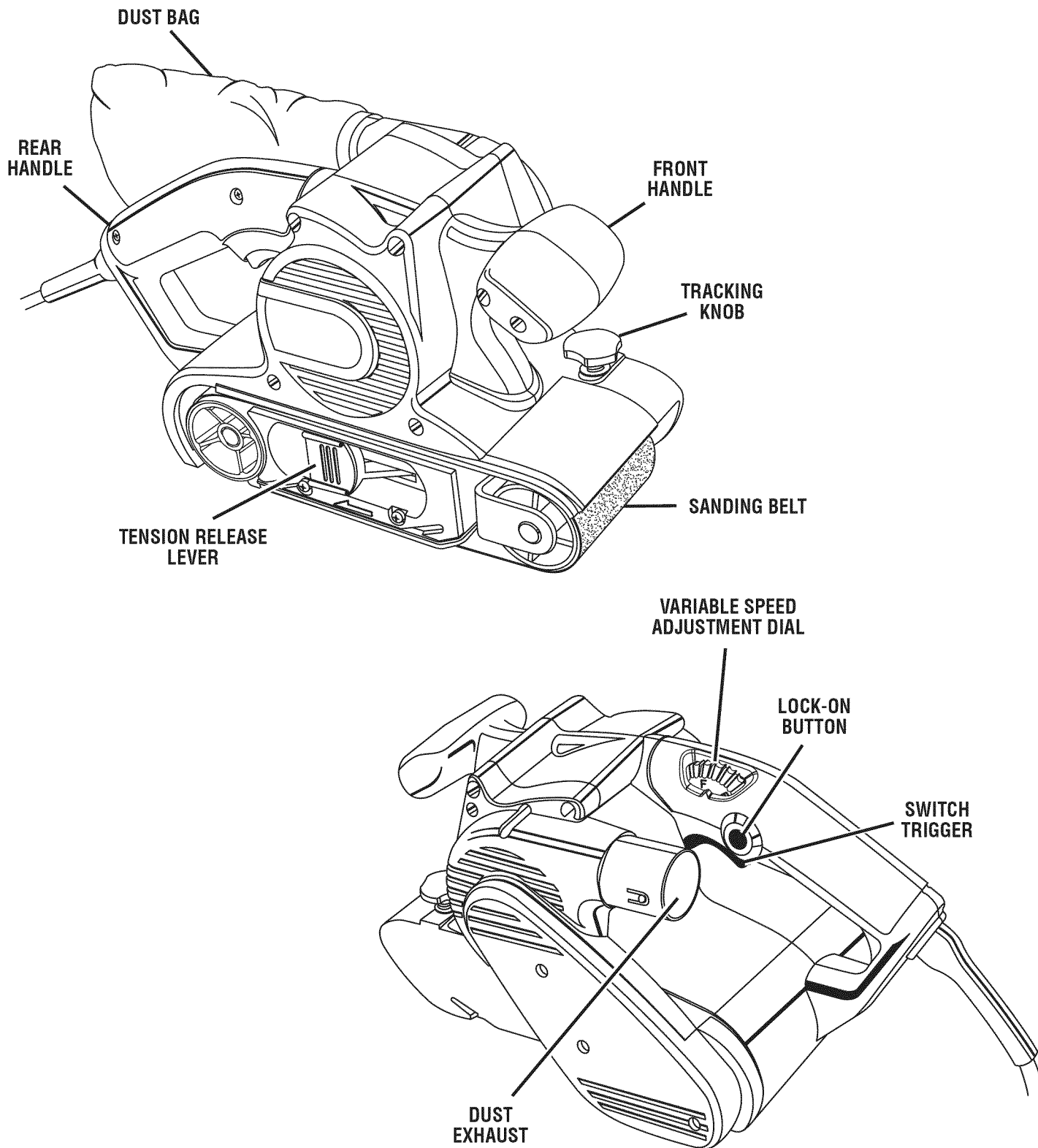

Fig. 1



# FEATURES

## KNOW YOUR BELT SANDER

See Figure 1.

Before attempting to use this product, familiarize yourself with all operating features and safety rules.

## DUST BAG

The dust bag attaches to the sander and keeps dust to a minimum.

## ERGONOMIC DESIGN

The design of the sander provides for easy handling. It is designed for comfort and ease of operation in different positions and at different angles.

## LOCK-ON BUTTON

The lock-on feature allows you to lock the switch trigger in the **ON** position. Locking the switch trigger on allows you to operate the sander for extended periods of time.

## TENSION RELEASE LEVER

The tension release lever aids in quick and easy belt changes.

## TRACKING KNOB

The tracking knob allows you to easily adjust the belt tracking.

## VARIABLE SPEED ADJUSTMENT DIAL

The variable speed adjustment dial allows you to adjust speeds from 800-1,300 surface feet per minute for different types of materials and applications.

# ASSEMBLY

## UNPACKING

This product has been shipped completely assembled.

- Carefully remove the tool and any accessories from the box. Make sure that all items listed in the packing list are included.
- Inspect the tool carefully to make sure no breakage or damage occurred during shipping.
- Do not discard the packing material until you have carefully inspected and satisfactorily operated the tool.
- If any parts are damaged or missing, please call 1-800-932-3188 for assistance.

## PACKING LIST

Belt Sander  
Sanding Belts (3)  
Dust Bag  
Case  
Operator's Manual

 **WARNING:** If any parts are missing do not operate this tool until the missing parts are replaced. Failure to do so could result in possible serious personal injury.

 **WARNING:** Do not attempt to modify this tool or create accessories not recommended for use with this tool. Any such alteration or modification is misuse and could result in a hazardous condition leading to possible serious personal injury.

 **WARNING:** Do not connect to power supply until assembly is complete. Failure to comply could result in accidental starting and possible serious injury.

# OPERATION

- ⚠ WARNING:** Do not allow familiarity with tools to make you careless. Remember that a careless fraction of a second is sufficient to inflict serious injury.
- ⚠ WARNING:** Always wear safety goggles or safety glasses with side shields when operating power tools. Failure to do so could result in objects being thrown into your eyes resulting in possible serious injury.
- ⚠ WARNING:** Do not use any attachments or accessories not recommended by the manufacturer of this tool. The use of attachments or accessories not recommended can result in serious personal injury.

## APPLICATIONS

You may use this tool for the purposes listed below:

- Sanding wood, metals, plastics, and other materials
- Smoothing rough boards, chamfering, rounding edges, etc.
- Removing rust, paint, varnishes, and stains

## SELECTING SANDING BELTS

Selecting the correct size and type of sanding belt is an important step in achieving a high quality sanded finish. Aluminum oxide, silicon carbide, and other synthetic abrasives are best for power sanding.

Coarse grit removes the most material and fine grit produces the best finish. The condition of the surface to be sanded determines which grit will do the best job. If the surface is rough, start with a coarse grit and sand until the surface is uniform. Then use medium grit to remove scratches left by the coarser grit. Finally, use finer grit for finishing the surface. Always continue sanding with each grit until the surface is uniform.

## INSTALLING/CHANGING SANDING BELTS

See Figures 2 - 4.

- Unplug the sander.
- Position the sander on its side with the cord on the left.

**⚠ WARNING:** Keep hands and fingers clear of the rollers and spring mechanism at all times. Failure to do so could result in fingers getting pinched, causing serious injury.

- Raise the tension release lever.

**NOTE:** If you are changing sanding belts, remove the old sanding belt at this time.

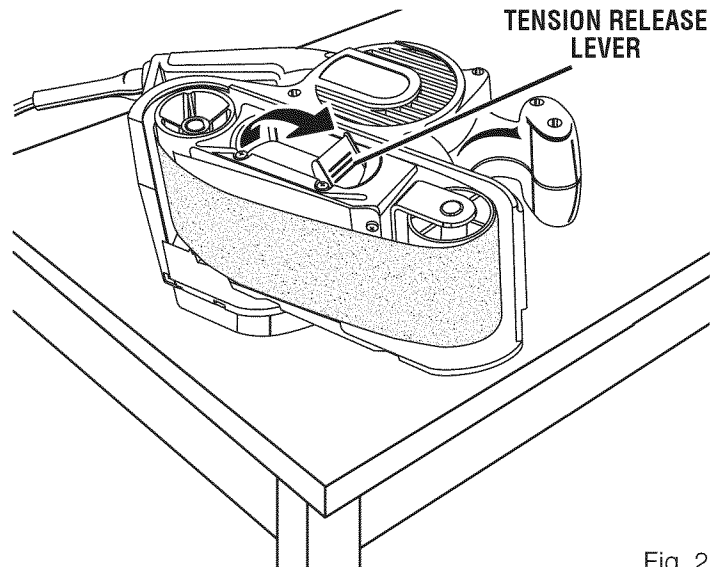

Fig. 2

- Install the sanding belt.

**⚠ CAUTION:** If the sanding belt is not a bidirectional belt, ensure that the arrow inside the belt is pointing in the direction of the rotation (clockwise when looking into the open side of the sander). Installing unidirectional sanding belts backwards can create a hazardous condition.

- Align the sanding belt to its correct position.
- Lower the tension release lever to secure the sanding belt.

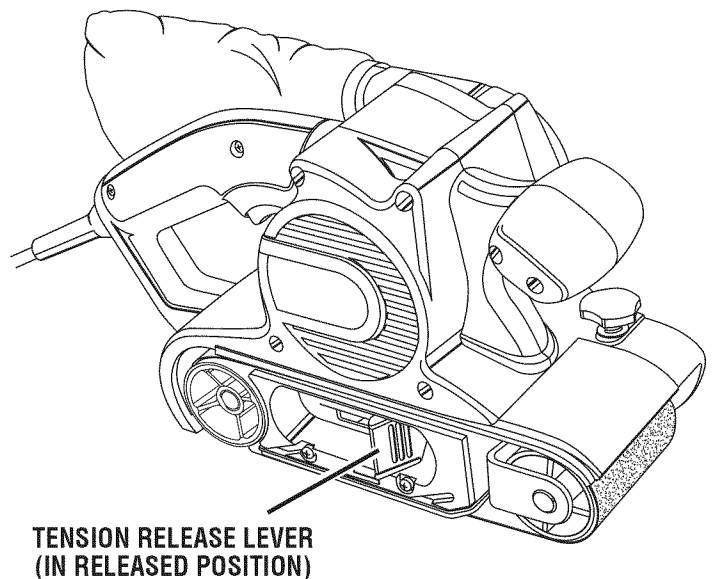
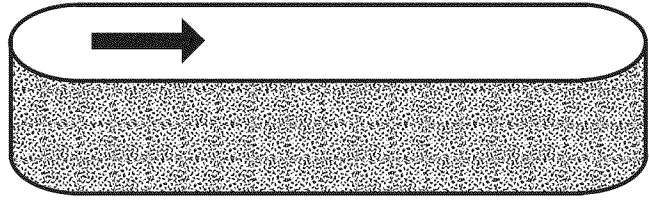
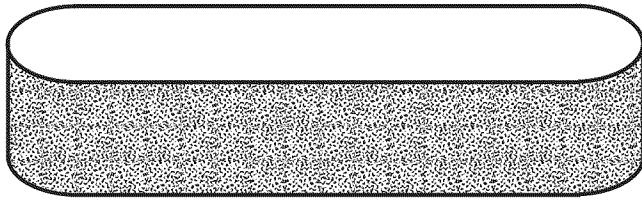

Fig. 3

# OPERATION



INSTALL UNIDIRECTIONAL BELTS IN THE DIRECTION OF THE ROTATION



INSTALL BIDIRECTIONAL BELTS IN EITHER DIRECTION

Fig. 4

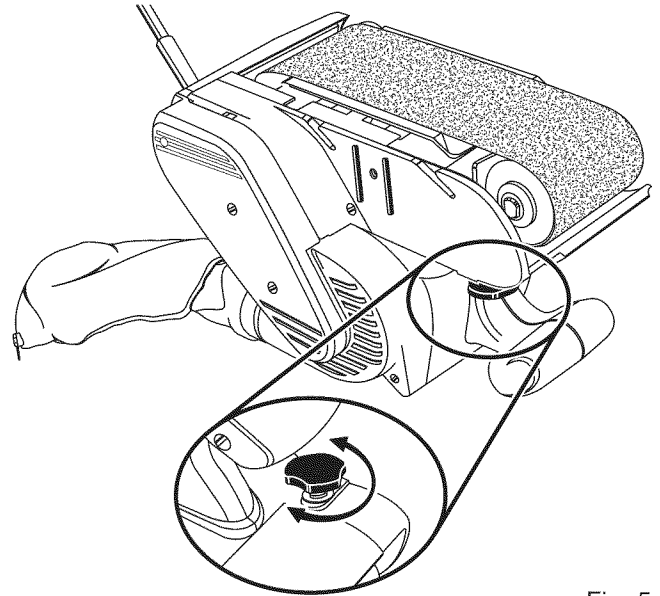

Fig. 5

**WARNING:** Before connecting the sander to a power supply, always make sure it is not in the “locked-on” position. Failure to do so could result in accidental starting of the sander resulting in possible serious injury.

**CAUTION:** If the sanding belt wears excessively on the inner edge, it is probably adjusted too far inward and is rubbing against internal parts. If this is the case, readjust the tracking knob.

## ADJUSTING SANDING BELT TRACKING

See Figures 5 - 6.

Belt life is greatly increased if you regularly adjust the sanding belt tracking. When correctly adjusted, the outer edge of the sanding belt should be even with the outer edge of the base of the sander.

When you install a new sanding belt, you may need to adjust the sanding belt tracking several times until the belt becomes pliable.

- Connect the sander to a power supply.
- Position the sander upside down with the cord on the left.

**NOTE:** This position is for adjustments only. The sanding belt should not contact a workpiece or any foreign object when you are making belt tracking adjustments.

- Depress the switch trigger and release immediately.
- Choose one of these options:
  - *Sanding belt runs inward:* Turn the tracking knob slowly clockwise.
  - *Sanding belt runs outward:* Turn the tracking knob slowly counterclockwise.

**NOTE:** Turn the tracking knob until you are sure the sanding belt is secure, i.e., it will not come off the sander or contact internal parts.

- Start the sander and fine adjust the tracking knob until the belt stabilizes.

**WARNING:** Keep hands and fingers away from a moving sanding belt. Any part of the body coming in contact with a moving sanding belt could result in serious injury. Do not wear loose clothing or jewelry when operating the sander. They could get caught in moving parts, and foreign objects could get thrown away from the sander, causing injury.

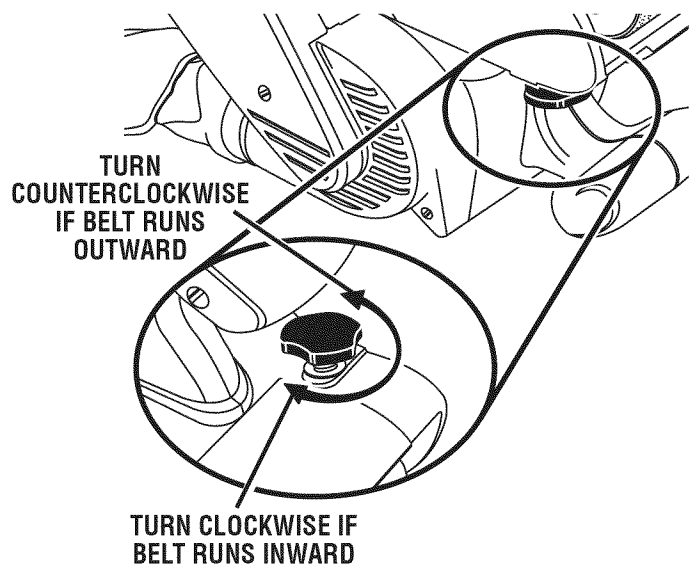

Fig. 6

# OPERATION

## USING THE DUST BAG

The dust bag provides a dust collection system for the sander.

**⚠ WARNING:** Do not use the dust bag when sanding metal. Using the dust bag when sanding metal creates a fire hazard, which could damage the tool and lead to serious personal injury.

## ATTACHING THE DUST BAG

See Figure 7.

- Unplug the sander.
- Slide the dust bag retainer over the dust exhaust on the sander.

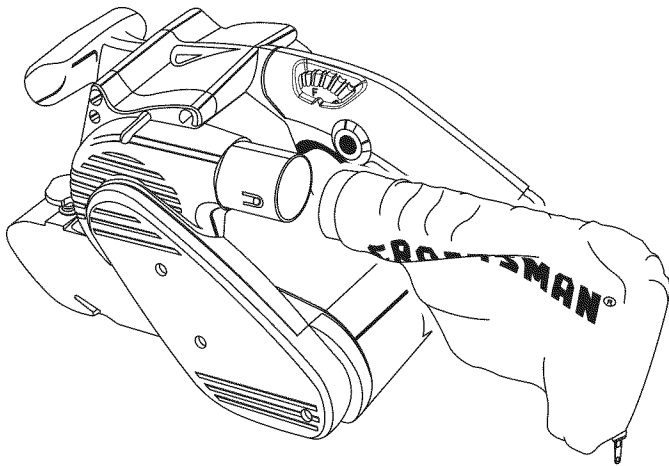

Fig. 7

## EMPTYING THE DUST BAG

For more efficient operation, empty the dust bag when it is no more than half full. This action permits the air to flow through the bag better. Always empty and clean the dust bag thoroughly upon completion of a sanding operation and before placing the sander in storage.

**⚠ WARNING:** Collected sanding dust from sanding surface coatings such as polyurethanes, linseed oil, etc., can self-ignite in the sander dust bag or elsewhere and cause fire. To reduce the risk of fire always empty the dust bag frequently (10-15 minutes) while sanding and never store or leave a sander without totally emptying its dust bag. Also follow the recommendations of the coatings manufacturers.

- Unplug the sander.
- Remove the dust bag from the sander.
- Unzip the dust bag.
- Shake out the dust.
- Zip up the dust bag.
- Replace the dust bag.

**NOTE:** Periodically, you should turn the dust bag inside-out and thoroughly clean it.

## SWITCH TRIGGER

See Figure 8.

- To turn on the sander: Depress the switch trigger.
- To turn off the sander: Release the switch trigger.

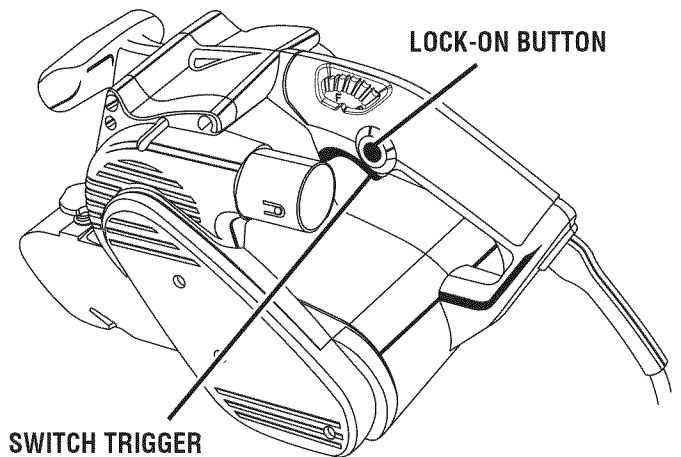

Fig. 8

## LOCK-ON BUTTON

See Figure 8.

The lock-on feature allows you to lock the switch trigger in the **ON** position. Locking the switch trigger on allows you to operate the sander for extended periods of time.

If you have the lock-on button engaged during use and the sander is accidentally disconnected from the power supply, disengage the lock-on feature immediately. Also, do not lock the switch trigger if you might need to suddenly stop the sander.

- Depress the switch trigger.
- Push in the lock-on button.
- Release the switch trigger.
- Release the lock-on button.

**NOTE:** To release the lock, depress the switch trigger.

# OPERATION

## PROPER HAND PLACEMENT

See Figure 9.

For ease of operation and maintaining proper control, the sander has a front handle and a rear handle. These handles allow two-handed operation, which aids in maintaining control, keeping the sanding area level with the workpiece, and keeping hands clear of the sanding belt. When operating the sander, always hold the front handle with your left hand and the rear handle with your right hand.

**⚠ WARNING:** Keep hands and fingers clear of moving sanding belt, front idler roller, and drive roller assembly. Failure to do so will result in serious personal injury.

**⚠ WARNING:** Do not let your fingers rest over the front or right edge of the sander. If the sanding belt were to run off, or if it were not properly adjusted, your fingers could come in contact with the moving sanding belt resulting in possible serious injury.

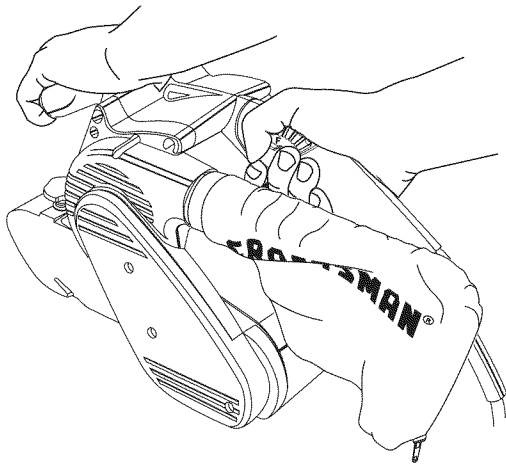

Fig. 9

## OPERATING THE SANDER

See Figure 10.

■ Secure the work to prevent it from moving under the sander.

**⚠ WARNING:** Unsecured work could be thrown towards the operator causing injury.

■ Turn the sander on and let the motor reach its maximum speed before placing the sander on the work surface.

■ Lower the sander to the work surface with a slight forward motion.

**⚠ WARNING:** Keep a firm grip on the sander with both hands at all times. Failure to do so could result in loss of control leading to possible serious injury.

■ Move the sander slowly over the work surface, using the rear handle to control the sander and the front handle to guide the sander.

**NOTE:** Allowing the sander to remain in one place will result in an uneven surface.

The sander is designed to provide the proper weight on the sanding belt.

If the sanding belt slips or does not track while sanding, you may be applying too much pressure.

Excessive pressure will result in uneven work, clogged sanding belts, premature sanding belt wear, possible motor burnout, and irregular sanding belt tracking.

When this occurs, remove the sander from the workpiece. If you properly adjust the belt tracking, the sanding belt will return to its normal and correct position on the drive roller and front roller.

Use a coarser sanding belt for heavy sanding, not heavy pressure. The weight of the tool is sufficient to provide adequate pressure at the correct location.

The front roller of the sander is not designed for contour sanding. Sanding on the front roller could cause irregularity in the sanding belt tracking.

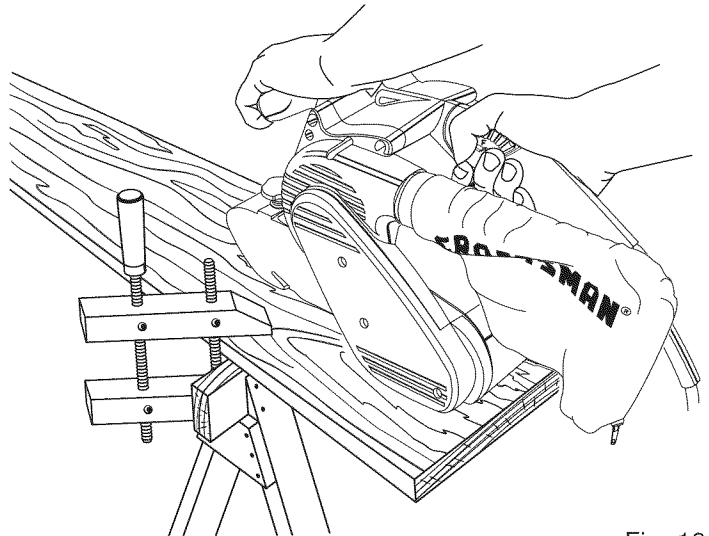

Fig. 10

# OPERATION

## SETTING THE BELT SANDER SPEED

The sander has a variable speed control dial, A to F, designed to allow operator control of belt speed. To increase belt speed, turn the variable speed control dial to a higher setting. Turn to a lower setting to decrease belt speed. Refer to the chart below for proper speed selections.

MATERIAL	SPEED						BELT GRIT					
	A	B	C	D	E	F	40	60	80	100	150	240
UNDRESSED TIMBER					★	★	●	●				
SOFTWOOD		★								●	●	
CHIPBOARD				★	★			●	●			
VENEER TIMBER	★	★										●
RUST REMOVAL			★	★			●	●				
PAINTED SURFACE					★	★	●	●				
NON FERROUS METAL			★						●	●		

# MAINTENANCE

**WARNING:** When servicing, use only identical Craftsman replacement parts. Use of any other parts may create a hazard or cause product damage.

**WARNING:** Always wear safety goggles or safety glasses with side shields during power tool operation or when blowing dust. If operation is dusty, also wear a dust mask.

## GENERAL MAINTENANCE

Avoid using solvents when cleaning plastic parts. Most plastics are susceptible to damage from various types of commercial solvents and may be damaged by their use. Use clean cloths to remove dirt, dust, oil, grease, etc.

**WARNING:** Do not at any time let brake fluids, gasoline, petroleum-based products, penetrating oils, etc., come in contact with plastic parts. Chemicals can damage, weaken or destroy plastic which may result in serious personal injury.

Electric tools used on fiberglass material, wallboard, spackling compounds, or plaster are subject to accelerated wear and possible premature failure because the fiberglass chips and grindings are highly abrasive to bearings, brushes, commutators, etc. Consequently, we do not recommend using this tool for extended work on these types of materials. However, if you do work with any of these materials, it is extremely important to clean the tool using compressed air.

## LUBRICATION

All of the bearings in this tool are lubricated with a sufficient amount of high grade lubricant for the life of the unit under normal operating conditions. Therefore, no further lubrication is required.

Only the parts shown on the parts list are intended to be repaired or replaced by the customer. All other parts should be replaced at a Sears Service Center.

# CRAFTSMAN BELT SANDER – MODEL NUMBER 315.117271

**SEE NOTE**

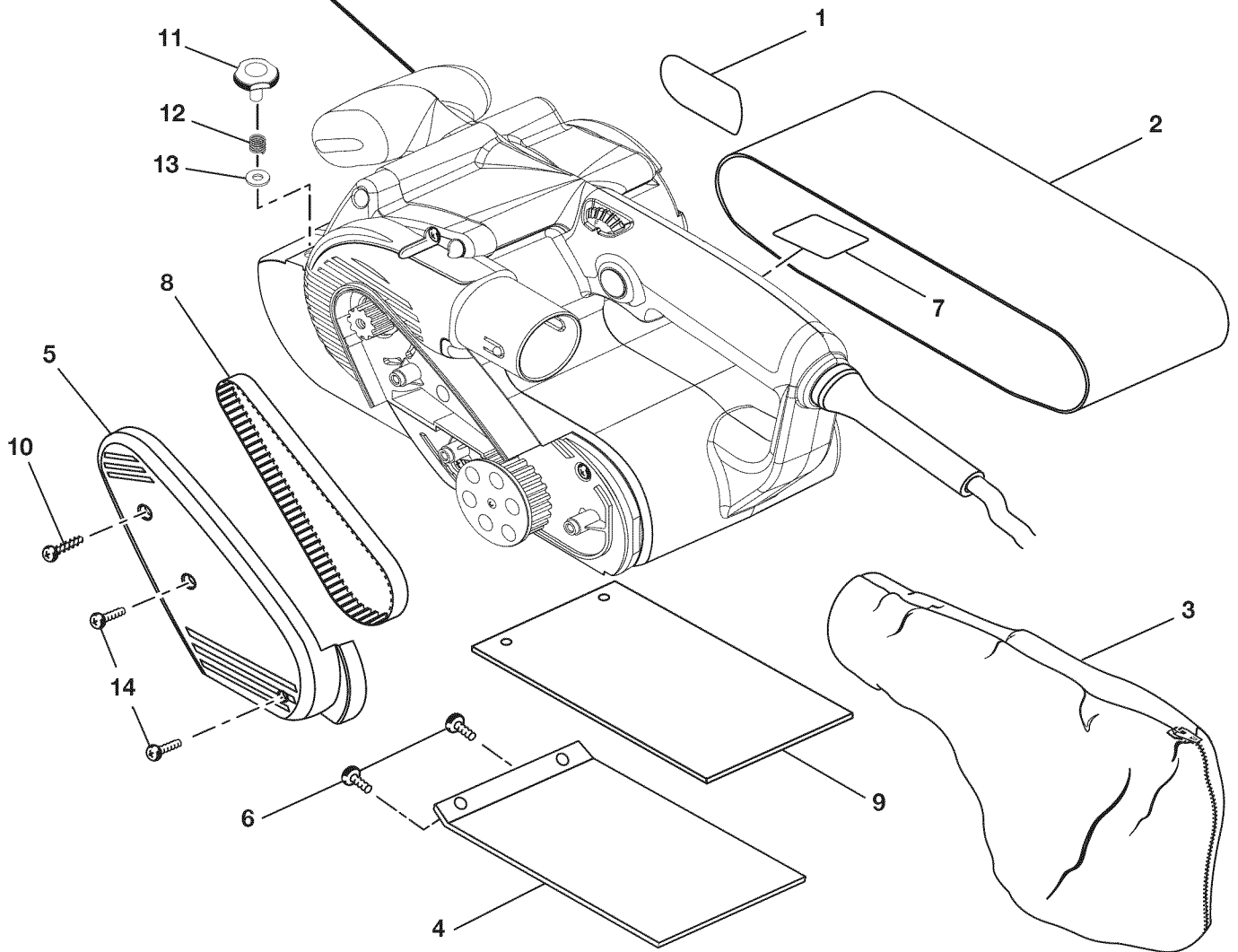

**NOTE:** The assembly shown represents an important part of the double insulated system. To avoid the possibility of alteration or damage to the system, service should be performed by your nearest Sears repair center. Contact your nearest Sears retail store for service center information.

## CRAFTSMAN BELT SANDER – MODEL NUMBER 315.117271

The model number will be found on a plate attached to the motor housing. Always mention the model number in all correspondence regarding your **BELT SANDER** or when ordering repair parts.

### SEE BACK PAGE FOR PARTS ORDERING INSTRUCTIONS

#### PARTS LIST

Key No.	Part No.	Description	Qty.
1	940211009	Logo Plate .....	1
2	***	Sanding Belt .....	1
3	300027035	Dust Bag.....	1
4	690711001	Wear Plate .....	1
5	590477001	Belt Cover.....	1
6	660312001	* Screw (8-32 x 3/8 in.) **STD510803 .....	2
7	940115105	Data Plate .....	1
8	590560001	Belt .....	1
9	900720001	Backing Pad .....	1
10	660272001	* Screw (M4 x 14 mm).....	1
11	590481001	Tracking Knob.....	1
12	690725001	Spring .....	1
13	680771001	Washer.....	1
14	660212013	* Screw (M4 x 14.5 mm).....	2
	983000752	Operator's Manual	

\* Standard Hardware Item – May Be Purchased Locally

\*\* Available From Div. 98 – Source 980.0

\*\*\* Complete assortment available at your Nearest Sears Retail Store