

# **SEARS** **OWNER'S** **MANUAL**

**MODEL NOS.**  
**247.799891**  
**247.799892**

**Caution:**  
**Read and Follow**  
**All Safety Rules**  
**and Instructions**  
**Before Operating**  
**This Equipment**

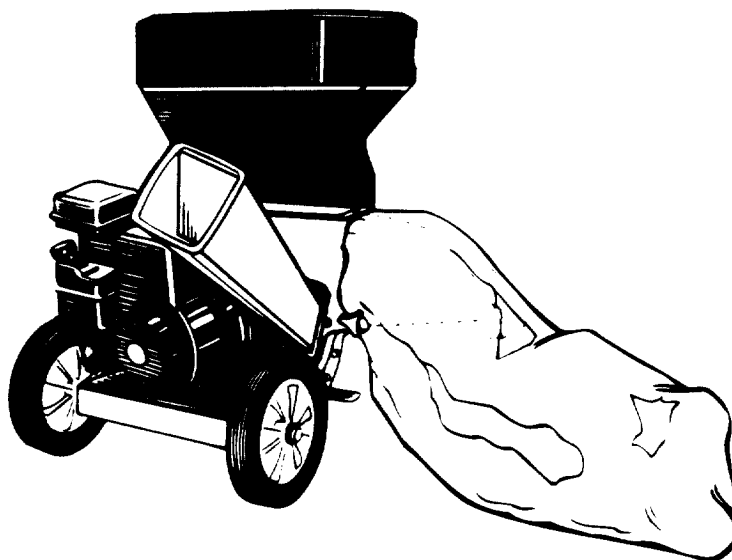

## **CRAFTSMAN®**

**5 HORSEPOWER**  
**3 CUTTING STAGE**  
**MULCHING AND BAGGING**  
**CHIPPER-SHREDDER**

**Assembly**  
**Operation**  
**Customer Responsibilities**  
**Service and Adjustment**  
**Repair Parts**

---

**SEARS, ROEBUCK AND CO., Hoffman Estates, IL 60195 U.S.A.**

# SAFETY RULES



**WARNING: TO REDUCE THE POTENTIAL FOR ANY INJURY, COMPLY WITH THE FOLLOWING SAFETY INSTRUCTIONS. FAILURE TO COMPLY WITH THE INSTRUCTIONS MAY RESULT IN PERSONAL INJURY.**

## TRAINING

- Read this owner's manual carefully in its entirety before attempting to assemble or operate this machine. Be completely familiar with the controls and the proper use of this machine before operating it. Keep this manual in a safe place for future and regular reference and for ordering replacement parts.
- Children must never be allowed to operate this equipment.
- No one should operate this unit while intoxicated or while taking medication that impairs the senses or reactions.
- This equipment should never be operated in the vicinity of children, pets or other persons.
- Never run your machine in an enclosed area as the exhaust from the engine contains carbon monoxide, which is an odorless, tasteless and deadly poisonous gas.
- Never place your hands or any part of your body or clothing inside the feeding chamber, discharge chute, or near any moving part while the machine or engine is running.
- If it is necessary for any reason to inspect or repair the feeding chamber or any part of the machine where a moving part can come in contact with your body or clothing, stop the machine, allow it to cool, disconnect the spark plug wire from the spark plug and move it away from the spark plug before attempting such inspection or repair.

## PREPARATION

- Wear safety glasses provided with your unit while operating the chipper-shredder to prevent injury from any material which may be ejected out of the openings.
- Wear proper apparel. Avoid wearing loose fitting clothing. Wear gloves when handling material.
- **HANDLE GASOLINE WITH CARE** as it is an extremely flammable fuel.
- Check the fuel before starting the engine. Do not fill the fuel tank indoors, while the engine is running, or while the engine is still hot. Turn the unit off and let the engine cool before refueling.
- Fuel your chipper-shredder in a clean area. Do not smoke while refueling.
- Fuel tank cap must be secure at all times except during refueling.
- Avoid spilling gasoline or oil. Wipe the unit clean of any spilled fuel or oil.
- Store fuel and oil in approved containers, away from heat or open flame, and out of reach of children.
- This machine should be operated only upon a level surface.
- Assure that all screws, nuts and bolts and other fasteners are properly secured.

## OPERATION

- When feeding shreddable material into this equipment, be extremely careful that pieces of metal, rocks, bottles, cans or other foreign objects are not included. Personal injury or damage to the machine could result.

- If the cutting mechanism strikes any foreign object or if your machine should start making an unusual noise or vibration, immediately stop the engine, disconnect the spark plug wire from the spark plug and move it away from the spark plug. Allow the machine to stop and take the following steps:
  - Inspect for damage.
  - Replace or repair any damaged parts.
  - Check for any loose parts and tighten to assure continued safe operation.
- The engine must be kept clean of debris and other accumulations.
- Do not allow an accumulation of processed material to build up in the discharge area as this will prevent proper discharge and can result in kick-back from feed opening.
- Never place your hands or any other part of your body or clothing inside the feeding chamber, discharge chute or near any moving part while the engine is running.
- Keep all guards and deflectors in place and in good working condition to assure continued safe operation.
- Always stand clear of the discharge area when operating this machine.
- Keep your face and body back from the feed opening to avoid accidental bounce back of any material.
- Do not over-reach. Keep proper balance and footing at all times.
- The engine governor settings on your machine must not be altered, changed, or tampered with. The governor controls the maximum safe operating speeds and protects the engine and all moving parts from damage caused by overspeed.
- Do not transport machine while engine is running.
- Do not operate engine if air cleaner or cover directly over carburetor air intake is removed, except for adjustment. Removal of such parts could create a fire hazard.

## MAINTENANCE AND STORAGE

- When this equipment is stopped for servicing, inspection, storage or to change an accessory, make sure the spark plug wire is disconnected from the spark plug and moved away from the spark plug. The machine should be allowed to cool down before making such inspection, adjustments, service, etc. Maintain your machine with care and keep it clean for the best and continued safe operation.
- Do not use flammable solutions to clean the air filter.
- When not in use, your machine should be stored out of the reach of children. Keep where gasoline fumes will not reach an open flame or spark. For long periods of storage, refer to the "Storage" section of this manual.



**LOOK FOR THIS SYMBOL TO POINT OUT IMPORTANT SAFETY PRECAUTIONS. IT MEANS—ATTENTION!!! BECOME ALERT!!! YOUR SAFETY IS INVOLVED.**

**CONGRATULATIONS** on your purchase of a Sears Craftsman Chipper-Shredder. It has been designed, engineered and manufactured to give you the best possible dependability and performance.

Should you experience any problem you cannot easily remedy, please contact your nearest Sears Service Center/ Department in the United States. We have competent, well-trained technicians and the proper tools to service or repair this unit.

Please read and retain this manual. The instructions will enable you to assemble and maintain your chipper-shredder properly. Always observe the "SAFETY RULES."

MODEL NUMBER _____
SERIAL NUMBER _____
DATE OF PURCHASE _____
THE MODEL AND SERIAL NUMBERS WILL BE FOUND ON A LABEL ATTACHED TO THE FRAME OF THE CHIPPER-SHREDDER.
YOU SHOULD RECORD BOTH SERIAL NUMBER AND DATE OF PURCHASE AND KEEP IN A SAFE PLACE FOR FUTURE REFERENCE.

**CUSTOMER RESPONSIBILITIES**

- Read and observe the safety rules.
- Follow a regular schedule in maintaining, caring for and using your chipper-shredder.
- Follow the instructions under "Customer Responsibilities" and "Storage" sections of this Owner's Manual.

**PRODUCT SPECIFICATIONS**

Horsepower:	5.0
Displacement:	12.57 cu. in.
Fuel Capacity:	3 Quarts (Unleaded)
Spark Plug (Gap .030 in.):	Champion J19LM (or Equivalent)
Magnetron® Ignition Air Gap:	.0125 in.

**MAINTENANCE AGREEMENT**

A Sears Maintenance Agreement is available on this product. Contact your nearest Sears store for details.

**WARNING:** This unit is equipped with an internal combustion engine and should not be used on or near any unimproved forest-covered, brush-covered or grass-covered land unless the engine's exhaust system is equipped with a spark arrester meeting applicable local or state laws (if any). If a spark arrester is used, it should be maintained in effective working order by the operator.

In the State of California the above is required by law (Section 4442 of the California Public Resources Code). Other states may have similar laws. Federal laws apply on federal lands. A spark arrester for the muffler is available through your nearest Sears Authorized Service Center (See the REPAIR PARTS section of this manual.)

**WARRANTY**

**ONE YEAR LIMITED WARRANTY ON CRAFTSMAN GAS CHIPPER-SHREDDER**

For one year from the date of purchase, when this Craftsman Chipper-Shredder is maintained, lubricated and tuned up according to the instructions in the owner's manual, Sears will repair, free of charge, any defect in material and workmanship.

If this Craftsman Chipper-Shredder is used for commercial or rental purposes, this warranty applies for only 30 days from the date of purchase.

This warranty does not cover:

- Expendable items which become worn during normal use, such as blades, chipper blades, flails, air cleaners, spark plugs and catcher bags.
- Repairs necessary because of operator abuse or negligence, including bent crankshafts and the failure to maintain the equipment according to the instructions contained in the owner's manual.

WARRANTY SERVICE IS AVAILABLE BY RETURNING THE CRAFTSMAN CHIPPER-SHREDDER TO THE NEAREST SEARS SERVICE CENTER/DEPARTMENT IN THE UNITED STATES. THIS WARRANTY APPLIES ONLY WHILE THIS PRODUCT IS IN USE IN THE UNITED STATES.

This warranty gives you specific legal rights, and you may also have other rights which may vary from state to state.

SEARS, ROEBUCK AND CO., D/817WA, Hoffman Estates, IL 60195

# TABLE OF CONTENTS

SAFETY RULES.....2	CUSTOMER RESPONSIBILITIES .....9-11
PRODUCT SPECIFICATIONS .....3	STORAGE .....11, 12
MAINTENANCE AGREEMENT .....3	SERVICE AND ADJUSTMENT .....12-14
CUSTOMER RESPONSIBILITIES .....3	TROUBLE SHOOTING.....15
WARRANTY .....3	PARTS ORDERING/SERVICE.....15
INDEX .....4	REPAIR PARTS—CHIPPER-SHREDDER .....16, 17
ASSEMBLY .....5	REPAIR PARTS—ENGINE .....18-21
OPERATION .....6-9	

## INDEX

<p style="text-align: center;"><b>A</b></p> <p>Adjustments:</p> <p style="padding-left: 20px;">Carburetor.....13, 14</p> <p style="padding-left: 20px;">Engine Speed .....14</p> <p>Assembly Instructions:</p> <p style="padding-left: 20px;">Catcher Bag.....5</p> <p style="padding-left: 20px;">Chute Deflector.....5</p> <p style="text-align: center;"><b>C</b></p> <p>Catcher Bag.....5</p> <p>Controls .....6</p> <p>Customer Responsibilities .....3, 9-11</p> <p style="text-align: center;"><b>E</b></p> <p>Engine:</p> <p style="padding-left: 20px;">Lubrication .....10</p> <p style="padding-left: 20px;">Maintenance .....10, 11</p> <p style="padding-left: 20px;">Starting .....8, 9</p> <p style="padding-left: 20px;">Stopping.....7</p> <p style="padding-left: 20px;">Storage .....11, 12</p> <p style="text-align: center;"><b>F</b></p> <p>Fuel.....8</p> <p style="text-align: center;"><b>L</b></p> <p>Lubrication .....10</p> <p style="text-align: center;"><b>M</b></p> <p>Maintenance:</p> <p style="padding-left: 20px;">Agreement .....3</p> <p style="padding-left: 20px;">Schedule.....9</p> <p style="padding-left: 20px;">Engine.....10, 11</p> <p style="padding-left: 20px;">Chipper-Shredder .....10</p>	<p style="text-align: center;"><b>O</b></p> <p>Oil .....8</p> <p>Operating Tips .....7</p> <p style="text-align: center;"><b>R</b></p> <p>Repair/Replacement Parts .....16-21</p> <p>Responsibilities, Customer .....3, 9-11</p> <p style="text-align: center;"><b>S</b></p> <p>Safety Rules .....2</p> <p>Sharpening .....12, 13</p> <p>Spark Plug .....11</p> <p>Specifications.....3</p> <p>Storage .....11, 12</p> <p style="text-align: center;"><b>T</b></p> <p>Table of Contents .....4</p> <p>Trouble Shooting .....15</p> <p style="text-align: center;"><b>U</b></p> <p>Unclogging.....12</p> <p>Unpacking.....5</p> <p style="text-align: center;"><b>W</b></p> <p>Warranty .....3</p>
--	---

# ASSEMBLY INSTRUCTIONS

**IMPORTANT:** This unit is shipped WITHOUT GASOLINE or OIL. After assembly, see operation section of this manual for proper fuel and engine oil recommendations.

**NOTE:** To determine right and left hand sides of your chipper-shredder, stand behind and face the hopper (engine is at the front of the unit).

Your chipper-shredder has been completely assembled at the factory, except for the chute deflector and the catcher bag. A pair of safety glasses are also included in the carton.

## TO REMOVE CHIPPER-SHREDDER FROM CARTON

Cut the corners of the carton. Remove all packing inserts. Roll chipper-shredder out of the carton. Make certain all parts, literature and the safety glasses have been removed before the carton is discarded.

## TOOLS REQUIRED FOR ASSEMBLY

(2) 7/16" or Adjustable Wrenches

## HOW TO SET-UP YOUR CHIPPER-SHREDDER



**MAKE CERTAIN THE SPARK PLUG WIRE IS DISCONNECTED AND MOVED AWAY FROM THE SPARK PLUG BEFORE ASSEMBLING THE CHIPPER-SHREDDER.**

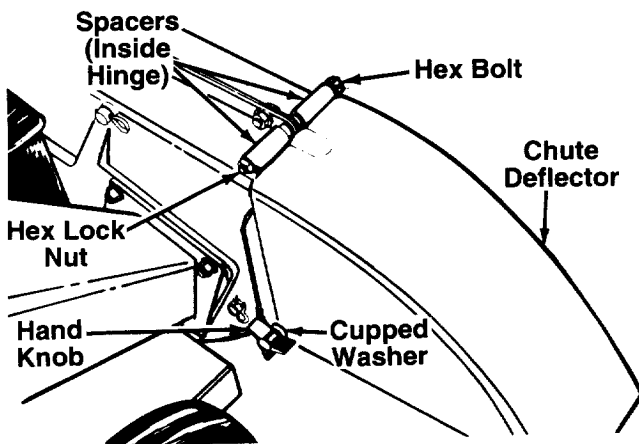

FIGURE 1.

### ← ATTACHING THE CHUTE DEFLECTOR

- Remove the hand knobs and cupped washers from each side of the discharge opening on the left side of the shredder.
- Remove the hex lock nut, two spacers and hex bolt from inside the hinge on top of the discharge opening. Do not remove one spacer from the hex bolt.
- Place the chute deflector in position on the discharge opening. Insert bolt through hinge on chute deflector and housing (spacer fits inside hinge).
- Place second spacer over the hex bolt, inside the other part of hinge. Secure with hex lock nut. Tighten securely.
- Secure both sides of the chute deflector to the housing using hand knobs and cupped washers (cupped side of washers go against chute deflector).

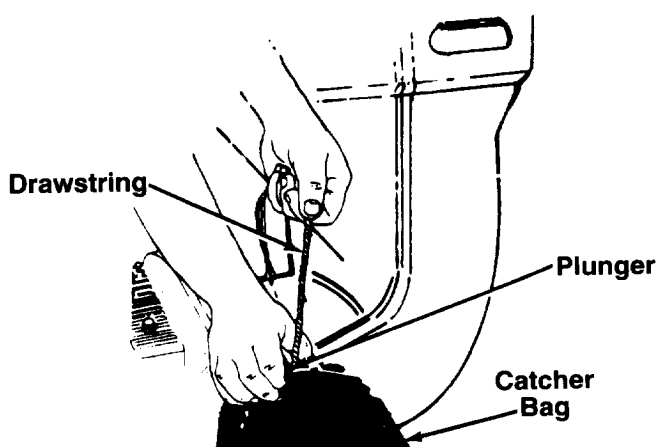

FIGURE 2.

### ATTACHING THE CATCHER BAG

Your chipper-shredder is equipped with a catcher bag to catch the shredded material.

- To attach bag, place bag opening over the chute deflector so it completely covers chute opening. Depress plunger on drawstring, pull on drawstring until bag is tight around chute opening. Release plunger to lock it into position. See figure 2.

---

# OPERATION

---

## KNOW YOUR CHIPPER-SHREDDER

READ THIS OWNER'S MANUAL AND SAFETY RULES BEFORE OPERATING YOUR CHIPPER-SHREDDER. Compare the illustrations with your chipper-shredder to familiarize yourself with the location of various controls and adjustments. Save this manual for future reference.

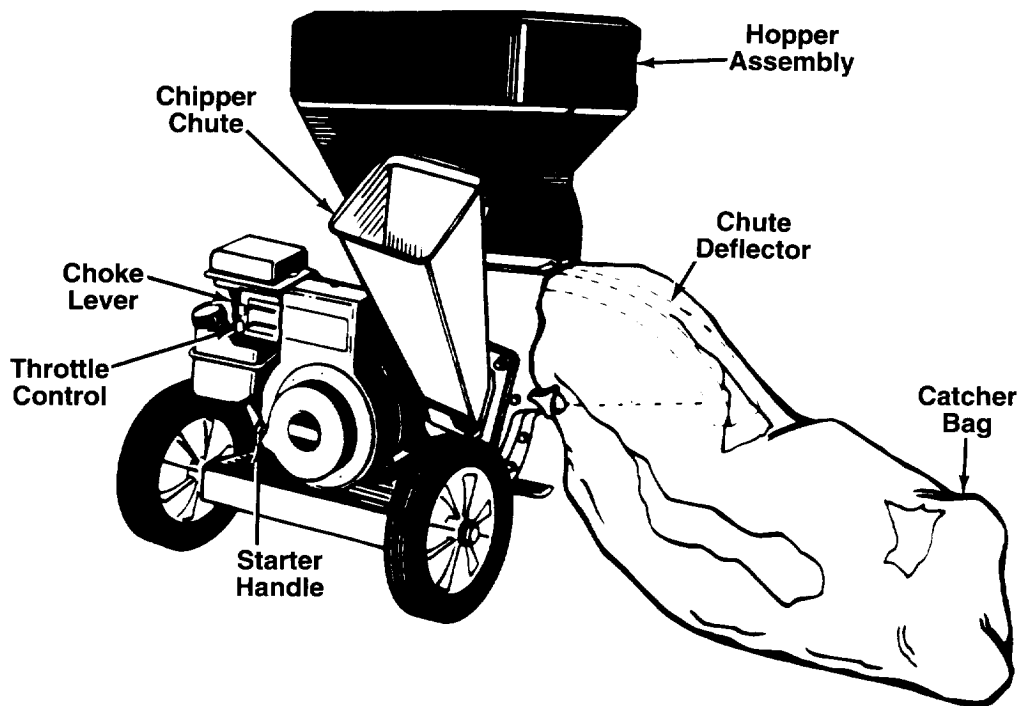

FIGURE 3.

---

## MEETS ANSI SAFETY STANDARDS

Sears chipper-shredders conform to the safety standards of the American National Standards Institute.

---

### OPERATING CONTROLS (See figure 3)

**CHOKE LEVER**—Used to enrich the fuel mixture in the carburetor when starting a cold engine.

**STARTER HANDLE**—Used to manually start the engine.

**THROTTLE CONTROL**—Controls engine speed and stops the engine.

---

BEFORE USING YOUR CHIPPER-SHREDDER, AGAIN REFER TO THE "SAFETY RULES" AS SHOWN ON PAGE 2 OF THIS MANUAL. ALWAYS BE CAREFUL.



The operation of any chipper-shredder can result in foreign objects being thrown into the eyes, which can result in severe eye damage. Always wear the safety glasses provided with the chipper-shredder or eye shields before chipping or shredding, or while performing any adjustments or repairs. We recommend Wide Vision Safety Mask for over spectacles or standard glasses available at Sears Retail or Catalog Stores.

## TO STOP ENGINE

- Move throttle control lever to OFF position. See figure 4.
- Disconnect spark plug wire and move away from spark plug to prevent accidental starting while equipment is unattended.

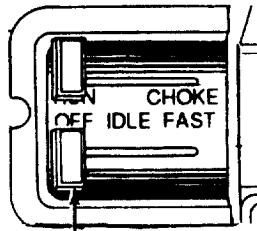

Throttle Control

FIGURE 4.

## HOW TO USE YOUR CHIPPER-SHREDDER

Do not attempt to shred or chip any material other than vegetation found in a normal yard (i.e., branches, leaves, twigs, etc.).



**WARNING: THE CHIPPER-SHREDDER DISCHARGES MATERIALS WITH CONSIDERABLE VELOCITY. KEEP AWAY FROM THE AREA AROUND THE CHUTE DEFLECTOR. ALWAYS STOP THE ENGINE AND DISCONNECT THE SPARK PLUG WIRE WHEN REMOVING OR ATTACHING THE BAG, WHEN CHANGING CONTAINERS OR WHEN REMOVING THE SHREDDED MATERIAL. WEAR SAFETY GLASSES AND GLOVES WHENEVER USING YOUR CHIPPER-SHREDDER.**

The chipper-shredder is designed for two different methods of operation.

- Leaves and small branches up to 1/2" diameter (recommended) or 1" diameter (maximum) can be fed into the hopper assembly. See figure 5. If it becomes necessary to push material into the chipper-shredder, use a small diameter stick—NOT YOUR HANDS. The stick should be small enough that it will be ground up if gets into the impeller assembly.



**WARNING: DO NOT PUT MATERIAL LARGER THAN 1/2" IN DIAMETER (RECOMMENDED) or 1" DIAMETER (MAXIMUM) INTO THE HOPPER ASSEMBLY. MATERIAL UP TO A MAXIMUM OF 3" IN DIAMETER MATERIAL MAY BE FED INTO THE CHIPPER CHUTE. DO NOT ATTEMPT TO SHRED OR CHIP ANY MATERIAL LARGER THAN 3" IN DIAMETER. PERSONAL INJURY OR DAMAGE TO THE MACHINE COULD RESULT.**

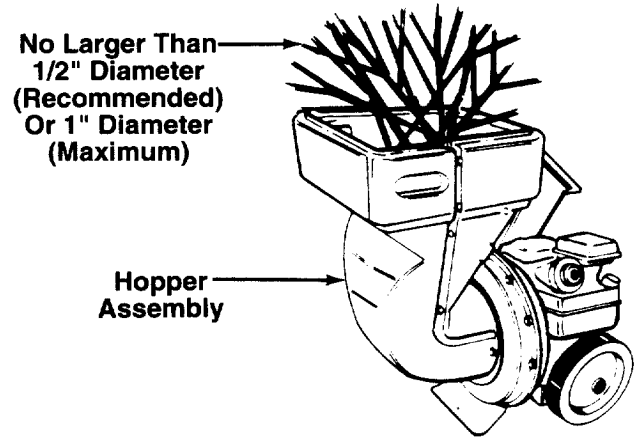

FIGURE 5.

- Bulky material, such as stalks or heavy branches, up to 3" in diameter, should be fed into the chipper chute. See figure 6.



**WARNING: MAKE CERTAIN THE CHIPPER CHUTE DOOR IS CLOSED WHEN NOT IN USE.**

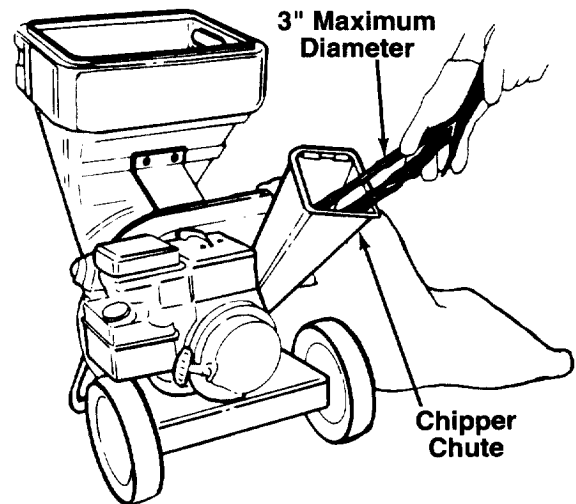

FIGURE 6.

**IMPORTANT:** There is a flail screen located inside the housing in the discharge area. If the flail screen becomes clogged, remove and clean as instructed in the Service and Adjustments section. For best performance, it is important to keep the shredding blade and the chipper blades sharp. If the composition of the material being discharged changes (becomes stringy, etc.) or if the rate at which the material is discharged slows down considerably, it is likely that the shredding blade and/or chipper blades are dull and need to be sharpened or replaced. Refer to Service and Adjustments section.

## GAS AND OIL FILL-UP

### OIL

Only use high quality detergent oil rated with API service classification SG. Select the oil's viscosity grade according to your expected operating temperature.

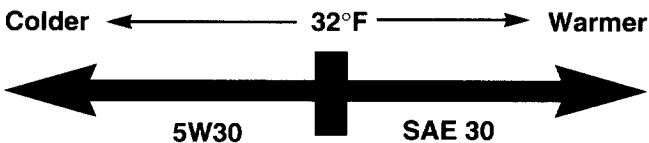

**NOTE:** Although multi-viscosity oils (5W30, 10W30, etc.) improve starting in cold weather, these multi-viscosity oils will result in increased oil consumption when used above 32°F. Check your oil level more frequently to avoid possible engine damage from running low on oil.

- Fill engine with oil as follows. Remove oil fill dipstick. See figure 7. With chipper-shredder level, use a funnel to fill engine with oil to FULL mark on dipstick. Capacity is approximately 1-1/4 pints. Be careful not to overfill. Tilt chipper-shredder toward the left (from behind the hopper), then re-level. Check oil level. Refill to FULL mark on dipstick if necessary. Replace dipstick and tighten.

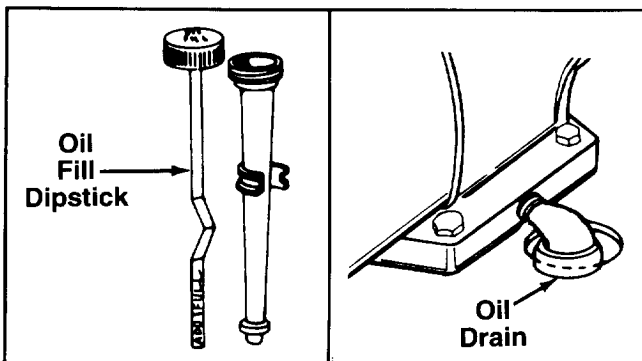

FIGURE 7.

### GAS

- Remove fuel cap and fill fuel tank with about 3 quarts of clean, fresh, lead-free grade automotive gasoline. DO NOT use Ethyl or high octane gasoline. Be certain container is clean and free from rust or foreign particles. Never use gasoline that may be stale from long periods of storage in the container. Replace fuel cap.



**WARNING: DO NOT FILL CLOSER THAN 1/2 INCH OF TOP OF FUEL TANK TO PREVENT SPILLS AND TO ALLOW FOR FUEL EXPANSION. IF GASOLINE IS ACCIDENTLY SPILLED, MOVE CHIPPER-SHREDDER AWAY FROM AREA OF SPILL. AVOID CREATING ANY SOURCE OF IGNITION UNTIL GASOLINE VAPORS HAVE DISAPPEARED.**

Check the fuel level periodically to avoid running out of gasoline while operating the chipper-shredder. If the unit runs out of gas as it is shredding or chipping, it may be necessary to unclog the unit before it can be restarted. Refer to "Removing the Flail Screen" in Service and Adjustment section.

**WARNING: EXPERIENCE INDICATES THAT ALCOHOL BLENDED FUELS (CALLED GASOHOL OR USING ETHANOL OR METHANOL) CAN ATTRACT MOISTURE WHICH LEADS TO SEPARATION AND FORMATION OF ACIDS DURING STORAGE. ACIDIC GAS CAN DAMAGE THE FUEL SYSTEM OF AN ENGINE WHILE IN STORAGE. TO AVOID ENGINE PROBLEMS, THE FUEL SYSTEM SHOULD BE EMPTIED OR TREATED WITH FUEL STABILIZER BEFORE STORAGE FOR 30 DAYS OR LONGER. USE FRESH FUEL NEXT SEASON. SEE "STORAGE" SECTION FOR ADDITIONAL INFORMATION.**

**NEVER USE ENGINE OR CARBURETOR CLEANER PRODUCTS IN THE FUEL TANK OR PERMANENT DAMAGE MAY OCCUR.**

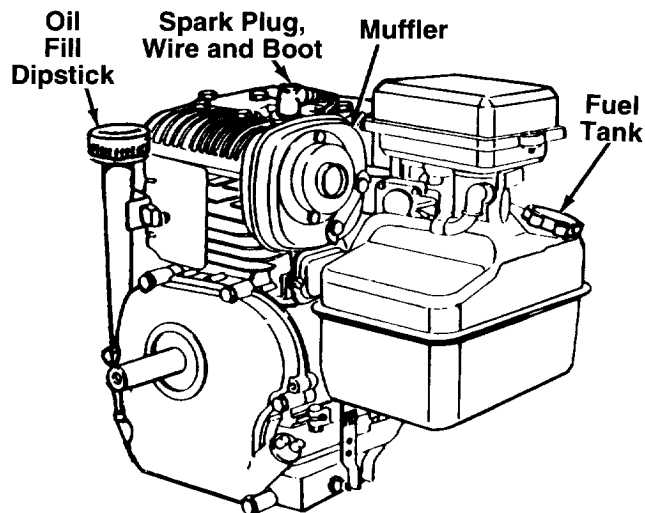

FIGURE 8.

### TO START ENGINE



**WARNING: BE SURE NO ONE OTHER THAN THE OPERATOR IS STANDING NEAR THE CHIPPER-SHREDDER WHILE STARTING OR OPERATING. DO NOT OPERATE THIS CHIPPER-SHREDDER UNLESS THE CHUTE DEFLECTOR HAS BEEN PROPERLY INSTALLED AND IS SECURED WITH THE HAND KNOBS.**



- Attach spark plug wire and rubber boot to spark plug if necessary. See figure 8.
- Place the throttle control lever in FAST position. See figure 9.
- Move choke lever to CHOKE position.
- Grasp starter handle (see figure 9) and pull rope out slowly until engine reaches start of compression cycle (rope will pull slightly harder at this point). Let the rope rewind slowly.

**NOTE:** A noise will be heard when finding the start of the compression cycle. This noise is caused by the flails and fingers which are part of the shredding mechanism falling into place, and should be expected. In addition, the flails and fingers will be noisy after the engine is started, until the impeller reaches full speed.

- Pull rope with a rapid, continuous, full arm stroke. Keep a firm grip on start handle. Let rope rewind slowly. Do not let starter handle snap back against starter.
- Repeat preceding two instructions until engine fires. When engine starts, move choke lever on engine halfway between CHOKE and RUN.

**NOTE:** If engine does not fire after three attempts, move choke lever halfway between CHOKE and RUN position and try again. See figure 9.

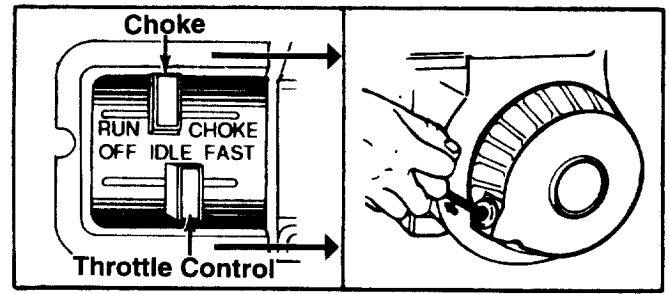

**FIGURE 9.**

- Move throttle control to IDLE position for a few minutes warm-up. Move choke lever to RUN position as engine warms up.

**NOTE:** In order to idle smoothly, a new engine may require 3 to 5 minutes running above slow idle speed. Idle speed has been adjusted to be correct after this break-in period.

### TO STOP ENGINE

- Move throttle control lever to OFF position. See figure 4.
- Disconnect spark plug wire and move away from spark plug to prevent accidental starting while equipment is unattended.

## CUSTOMER RESPONSIBILITIES

MAINTENANCE SCHEDULE FILL IN DATES AS YOU COMPLETE REGULAR SERVICE								SERVICE DATES						
		BEFORE EACH USE	AFTER EACH USE	FIRST FIVE HOURS	EVERY 25 HOURS	EVERY 50 HOURS	BEFORE STORAGE							
PRODUCT	Oil Pivot Points						✓							
	Clean Shredder		✓				✓							
ENGINE	Check Engine Oil	✓												
	Change Engine Oil			✓	✓									
	Service Air Cleaner				✓									
	Clean Engine Cylinder				✓		✓							
	Spark Plug				✓		✓							
	Muffler					✓								

✓ CHECK

## GENERAL RECOMMENDATIONS



**WARNING: ALWAYS STOP THE ENGINE AND DISCONNECT THE SPARK PLUG WIRE BEFORE PERFORMING ANY MAINTENANCE OR ADJUSTMENTS.**

- Periodically check all fasteners and be sure they are tight.
- Follow the Maintenance Schedule on previous page.

## CHIPPER-SHREDDER LUBRICATION

Lubricate the pivot points on the chute deflector and chipper chute once a season using a light oil.

## ENGINE ENGINE OIL

Only use high quality detergent oil rated with API service classification SG. Select the oil's viscosity grade according to your expected operating temperature.

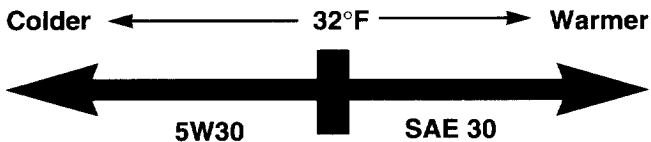

**NOTE:** Although multi-viscosity oils (SE30, 10W30, etc.) improve starting in cold weather, these multi-viscosity oils will result in increased oil consumption when used above 32°F. Check your oil level more frequently to avoid possible engine damage from running low on oil.

Your four-cycle engine will normally consume some oil—therefore, check engine oil level regularly approximately every five hours of operation and before each usage. Stop engine and wait several minutes before checking oil level. With engine level, the oil must be to FULL mark on dipstick (refer to figure 7). Change engine oil after the first five hours of operation, and every twenty-five hours thereafter.

### To Drain Oil:

- Drain oil while engine is warm.
  - a. Remove oil drain plug. Refer to figure 7. Catch oil in a suitable container.
  - b. When engine is drained of all oil, replace drain plug securely.
- Refill with fresh oil. Refer to GAS AND OIL FILL-UP section.
- Replace dipstick.

## AIR CLEANER

The air cleaner prevents damaging dirt, dust, etc., from entering the carburetor and being forced into the engine and is important to engine life and performance.

**Never run your engine without air cleaner completely assembled.**

### To Service Air Cleaner:

Service pre-cleaner after every 25 hours of use, or at least once a season. Service cartridge every 100 hours of use, or at least once a season. Service pre-cleaner and cartridge more often under dusty conditions.

- Loosen screw and remove cover.
- To service pre-cleaner, wash in liquid detergent and water. Squeeze dry in a clean cloth. Saturate in engine oil. Squeeze in a clean, absorbent cloth to remove all excess oil. If pre-cleaner is very dirty, replace it.
- To service cartridge, clean by tapping gently on a flat surface. If very dirty, replace. Do not oil cartridge.

**NOTE:** Do not use petroleum solvents (e.g. kerosene) or pressurized air to clean cartridge. They will cause cartridge to deteriorate.

- Reinstall cartridge and pre-cleaner.
- Replace cover, and tighten screws securely.

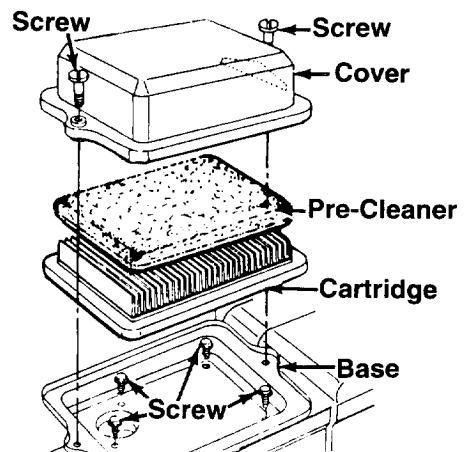

**FIGURE 10.**

## CLEAN ENGINE

Clean engine periodically. Remove dirt and debris with a cloth or brush. Cleaning with a forceful spray of water is not recommended as water could contaminate the fuel system.

Yearly or every 25 hours, whichever occurs first, remove the blower housing and clean the areas shown in figure 11 to avoid overspeeding, overheating and engine damage. Clean more often if necessary.



**WARNING: PERIODICALLY CLEAN MUFFLER AREA TO REMOVE ALL GRASS, DIRT AND COMBUSTIBLE DEBRIS.**

#### CLEANING

- The chipper-shredder may be cleaned by running water from a hose through the hopper assembly and chipper chute with the engine running. Allow the chipper-shredder to dry thoroughly.
- Wash the bag periodically with water. Allow to dry thoroughly in the shade. Do not use heat.

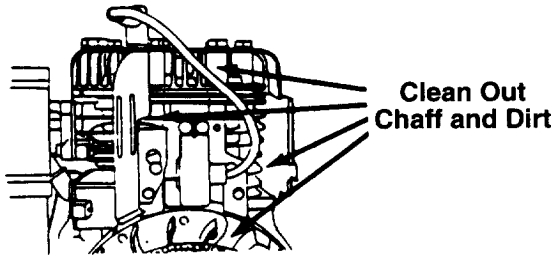

FIGURE 11.

#### SPARK PLUG

The spark plug should be cleaned and the gap reset to .030" at least once a season or every 50 hours of operation. See figure 12. Spark plug replacement is recommended at the start of each season. Refer to engine parts list for correct spark plug type.

**NOTE:** Do not sandblast spark plug. Spark plug should be cleaned by scraping or wire brushing and washing with a commercial solvent.

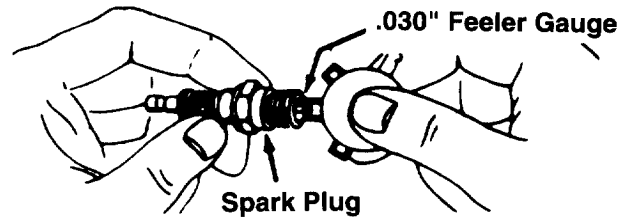

FIGURE 12.

#### MUFFLER

Do not operate the chipper-shredder without a muffler or tamper with the exhaust system. Damaged mufflers or spark arresters could create a fire hazard. Inspect periodically, and replace if necessary. If your engine is equipped with a spark arrester screen assembly, remove every 50 hours for cleaning and inspection. Replace if damaged.

---

## STORAGE

---

Prepare your chipper-shredder for storage at the end of the season or if the unit will not be used for 30 days or more.



**WARNING: NEVER STORE MACHINE WITH FUEL IN THE FUEL TANK INSIDE OF BUILDING WHERE FUMES MAY REACH AN OPEN FLAME OR SPARK, OR WHERE IGNITION SOURCES ARE PRESENT SUCH AS HOT WATER AND SPACE HEATERS, FURNACES, CLOTHES DRYERS, STOVES, ELECTRIC MOTORS, ETC.**

**NOTE:** A yearly check-up by your local Sears Service Center is a good way to make certain your chipper-shredder will provide maximum performance for the next season.

#### CHIPPER-SHREDDER

- Clean the chipper-shredder thoroughly.

- Wipe unit with an oiled rag to prevent rust (use a light oil or silicone).

#### ENGINE

**IMPORTANT:** IT IS IMPORTANT TO PREVENT GUM DEPOSITS FROM FORMING IN ESSENTIAL FUEL SYSTEM PARTS SUCH AS CARBURETOR, FUEL FILTER, FUEL HOSE, OR TANK DURING STORAGE. ALSO, EXPERIENCE INDICATES THAT ALCOHOL BLENDED FUELS (CALLED GASOHOL OR USING ETHANOL OR METHANOL) CAN ATTRACT MOISTURE WHICH LEADS TO SEPARATION AND FORMATION OF ACIDS DURING STORAGE. ACIDIC GAS CAN DAMAGE THE FUEL SYSTEM OF AN ENGINE WHILE IN STORAGE.

- Drain the fuel tank.
- Start the engine and let it run until the fuel lines and carburetor are empty.
- Never use engine or carburetor cleaner products in the fuel tank or permanent damage may occur.
- Use fresh fuel next season.

**NOTE:** Fuel stabilizer is an acceptable alternative in minimizing the formation of fuel gum deposits during storage. Add stabilizer to gasoline in fuel tank or storage container. Always follow the mix ratio found on stabilizer container. Run engine at least 10 minutes after adding stabilizer to allow the stabilizer to reach the carburetor. Do not drain the gas tank and carburetor if using fuel stabilizer.

- Drain all the oil from the crankcase (this should be done after the engine has been operated and is still warm) and refill the crankcase with fresh oil.
- If you have drained the fuel tank, protect the inside of the engine as follows. Remove spark plug, pour

approximately 1/2 ounce (approximately one tablespoon) of engine oil into cylinder and crank slowly to distribute oil. Replace spark plug.

## OTHER

- Do not store gasoline from one season to another.
- Replace your gasoline can if your can starts to rust. Rust and/or dirt in your gasoline will cause problems.
- Store unit in a clean, dry area. Do not store next to corrosive materials, such as fertilizer.

**NOTE:** If storing in an unventilated or metal storage shed, be certain to rustproof the equipment by coating with a light oil or silicone.

## SERVICE & ADJUSTMENT



**WARNING: ALWAYS STOP ENGINE AND DISCONNECT SPARK PLUG WIRE AND MOVE IT AWAY FROM SPARK PLUG BEFORE PERFORMING ANY ADJUSTMENTS OR REPAIRS.**

### REMOVING THE FLAIL SCREEN

If the discharge area becomes clogged, remove the flail screen and clean area as follows.

- Stop the engine, make certain the chipper-shredder has come to a complete stop and disconnect spark plug wire from the spark plug before unclogging the chute.
- Loosen the two hand knobs on each side of the chute deflector. Lift the chute deflector up, and tie it out of the way.
- Remove two hairpin clips from the clevis pins which extend through the housing. Remove the clevis pins. Lift the flail screen from inside the housing. See figure 13.
- Clean the screen by scraping or washing with water. Reinstall the screen.

**NOTE:** Be certain to reassemble the flail screen with the curved side down as shown in figure 13.

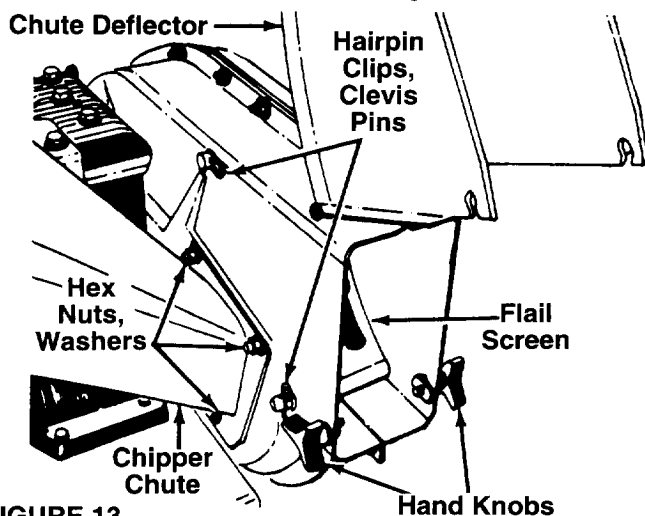

FIGURE 13.

### SHARPENING OR REPLACING THE BLADES

#### CHIPPER BLADES

- Disconnect spark plug wire and move it away from spark plug.
- Remove the flail screen as instructed in previous section.
- Remove the chipper chute by removing three hex nuts and washers. A 1/2" wrench is required. See figure 13.

**NOTE:** When reassembling, the cupped washer goes on the bottom of the chipper chute with the cupped side against the chute.

- Rotate the impeller assembly by hand until you locate one of the chipper blades in the chipper chute opening. Remove the blade, using a 3/16" allen wrench on the outside of the blade and 1/2" wrench on the impeller assembly (inside the housing). See figure 14.
- Remove the other blade in the same manner.

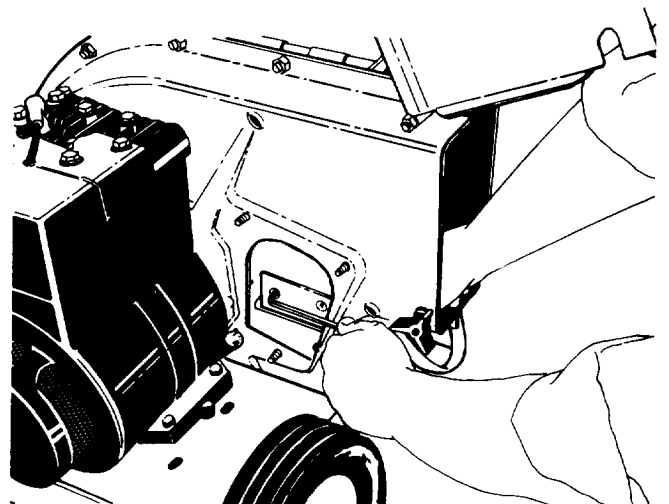

FIGURE 14.

Replace or sharpen blades. If sharpening, make certain to remove an equal amount from each blade. Reassemble in reverse order.

Make certain blades are reassembled with the sharp edge facing the direction shown in figure 19 (sharp edge is assembled toward the slotted opening in the impeller assembly).

### SHREDDING BLADE

The shredding blade may be removed for sharpening or replacement as follows.

- Disconnect spark plug wire and move it away from spark plug.
- Lower the hopper assembly. Block up the housing. See figure 15.
- Remove the six hex lock nuts and lock washers from the housing weld bolts using a 1/2" wrench. Separate the chipper-shredder into two halves.
- Remove the back-up plate.

**NOTE:** When reassembling, make certain the opening on the back-up plate is toward the bottom of the unit. The back-up plate may be reversed to provide a new cutting edge.

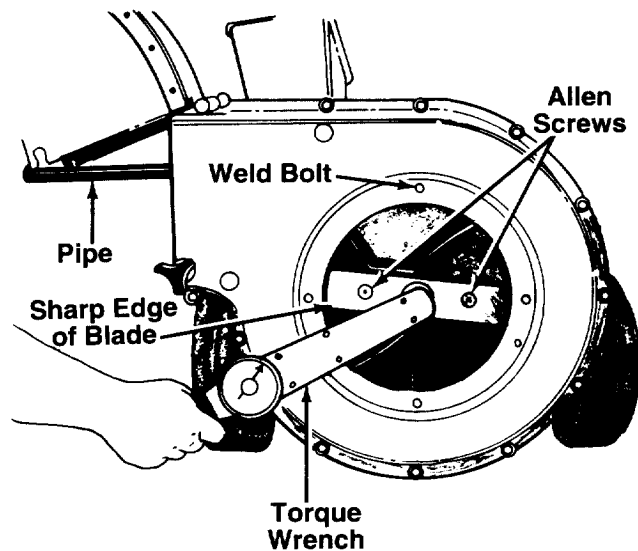
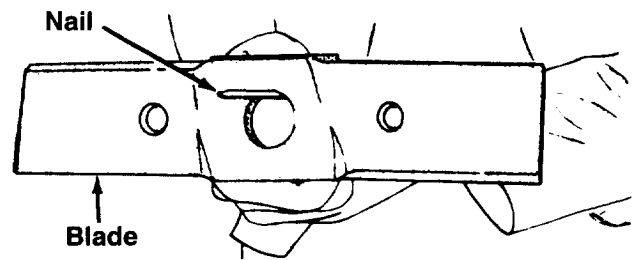

**FIGURE 15.**

- Loosen the two hand knobs and cupped washers which secure the chute deflector, and raise the chute deflector.
- Insert a 1/2" or 3/4" diameter pipe through the flail screen into the impeller to keep it from turning, or remove the flail screen and insert a piece of wood (2 x 4) into the chute opening.
- Remove the two outside screws on the blade, using a 3/16" allen wrench and a 1/2" wrench.
- Remove the blade by removing the center bolt, lock washer and flat washer.

**NOTE:** Use caution when removing the blade to avoid contacting the weld bolts on the housing.

- When sharpening the blade, follow the original angle of grind as a guide. It is extremely important that each cutting edge receives an equal amount of grinding to prevent an unbalanced blade. An unbalanced blade will cause excessive vibration when rotating at high speeds and may cause damage to the unit.
- The blade can be tested for balance by balancing it on a round shaft screwdriver or nail. Remove metal from the heavy side until it is balanced evenly. See figure 16.



**FIGURE 16.**

- When reassembling the blade, tighten to between 550 and 650 inch pounds, or lacking torque wrench, tighten securely.

### FLAILS

The flails, located inside the housing, may be reversed when they become dull. It is suggested that this procedure be performed by your nearest Sears Service Department.

### CARBURETOR ADJUSTMENT



**WARNING: IF ANY ADJUSTMENTS ARE MADE TO THE ENGINE WHILE THE ENGINE IS RUNNING (E.G. CARBURETOR), KEEP CLEAR OF ALL MOVING PARTS. BE CAREFUL OF HEATED SURFACES AND MUFFLER.**

Minor carburetor adjustment may be required to compensate for differences in fuel, temperature, altitude or load.

**NOTE:** A DIRTY AIR CLEANER WILL CAUSE ENGINE TO RUN ROUGH. BE CERTAIN AIR CLEANER IS CLEAN AND ATTACHED TO THE CARBURETOR BEFORE ADJUSTING CARBURETOR. DO NOT MAKE UNNECESSARY ADJUSTMENTS. FACTORY SETTINGS ARE SATISFACTORY FOR MOST APPLICATIONS AND CONDITIONS.

Never attempt to change maximum engine speed. It is pre-set at the factory and should be changed only by a qualified service technician who has the necessary equipment.

The carburetor may need re-adjusting if engine lacks power or does not idle properly. If adjustments are needed, proceed as follows.

- Close needle valve (see figure 17) clockwise (↻) finger tight only. Forcing may cause damage. Then open 1-1/2 turns counterclockwise (↺).
- Start engine and allow to warm for five minutes.
- With throttle in FAST position, close needle valve clockwise (↻) until engine starts to lose speed (lean mixture). Then slowly open needle valve counterclockwise (↺) until engine JUST BEGINS to run unevenly. This mixture should be rich enough for best performance under load.
- Place throttle control in IDLE position.  
If engine idles, no further adjustment is necessary.  
If engine idles too fast, turn idle speed adjusting screw counterclockwise (↺) until slower speed is obtained.  
If engine dies, turn idle speed adjusting screw 1/4 turn clockwise (↻). Place throttle control in FAST position and restart engine.  
Move throttle control to IDLE position. If engine does not idle, repeat third step.
- Test the engine by using the chipper-shredder. If engine tends to stall or die out, it usually indicates that the mixture is slightly lean and it may be necessary to open (↺) the needle valve slightly to provide a richer mixture. This richer mixture may cause a slight unevenness in idling.

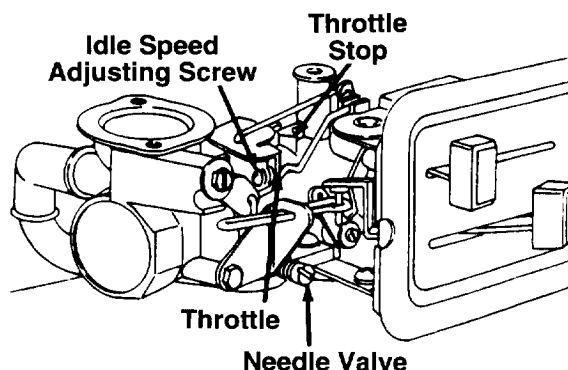

FIGURE 17.

## ENGINE SPEED

Your engine speed has been factory set. Do not attempt to increase engine speed or it may result in personal injury. If you believe the engine is running too fast or too slow, take your chipper-shredder to the nearest SEARS Service Center for repair and adjustment.

## TROUBLE SHOOTING

PROBLEM	POSSIBLE CAUSE(S)	CORRECTIVE ACTION
Engine fails to start	<ul style="list-style-type: none"> <li>● Fuel tank empty, or stale fuel.</li> <li>● Spark plug wire disconnected.</li> <li>● Faulty spark plug.</li> </ul>	<ul style="list-style-type: none"> <li>● Fill tank with clean, fresh fuel.</li> <li>● Connect wire to spark plug.</li> <li>● Clean, adjust gap or replace.</li> </ul>
Loss of power; operation erratic	<ul style="list-style-type: none"> <li>● Spark plug wire loose.</li> <li>● Unit running on CHOKE.</li> <li>● Blocked fuel line or stale fuel.</li> <li>● Water or dirt in fuel system.</li> <li>● Carburetor out of adjustment.</li> <li>● Dirty air cleaner.</li> </ul>	<ul style="list-style-type: none"> <li>● Connect and tighten spark plug wire.</li> <li>● Move choke lever to OFF position.</li> <li>● Clean fuel line; fill tank with clean fresh gasoline.</li> <li>● Disconnect fuel line at carburetor to drain fuel tank. Refill with fresh fuel.</li> <li>● Adjust carburetor or contact your SEARS Service Center.</li> <li>● Service air cleaner. See Customer Responsibilities section of this manual.</li> </ul>
Engine overheats	<ul style="list-style-type: none"> <li>● Carburetor not adjusted properly.</li> <li>● Engine oil level low.</li> </ul>	<ul style="list-style-type: none"> <li>● Contact your SEARS Service Center.</li> <li>● Fill crankcase with proper oil.</li> </ul>
Too much vibration	<ul style="list-style-type: none"> <li>● Loose parts or damaged impeller.</li> </ul>	<ul style="list-style-type: none"> <li>● Stop engine immediately and disconnect spark plug wire. Tighten all bolts and nuts. Make all necessary repairs. If vibration continues, have unit serviced by a SEARS Service Center.</li> </ul>
Unit does not discharge	<ul style="list-style-type: none"> <li>● Discharge chute clogged.</li> <li>● Foreign object lodged in impeller.</li> </ul>	<ul style="list-style-type: none"> <li>● Stop engine immediately and disconnect spark plug wire. Clean flail screen and inside of blower housing. See Service/Adjustments section of this manual.</li> <li>● Stop engine immediately and disconnect spark plug wire. Remove lodged object.</li> </ul>
Rate of discharge slows considerably or composition of discharged material changes	<ul style="list-style-type: none"> <li>● Shredding blade and/or chipper blades dull.</li> </ul>	<ul style="list-style-type: none"> <li>● Sharpen or replace shredding and chipper blades.</li> </ul>

NOTE: For repairs beyond the minor adjustments listed above, please contact your nearest SEARS Service Center.

## HOW TO ORDER REPLACEMENT PARTS

Each chipper-shredder has its own model number. Each engine has its own model number.

The model number for your chipper-shredder will be found on a label attached to the frame.

The model number for the engine will be found on the blower housing of the engine.

All parts listed herein may be ordered through Sears, Roebuck and Co. Service Centers and most Retail Stores.

**WHEN ORDERING REPAIR PARTS, ALWAYS GIVE THE FOLLOWING INFORMATION:**

**\*PRODUCT - "5 H.P. Chipper-Shredder"**

**\*MODEL NUMBER - 247.799891  
247.799892**

**\*ENGINE MODEL NO. - 135212-0272-01  
135212-0140-01**

**\*PART NUMBER**

**\*PART DESCRIPTION**

Your Sears merchandise has added value when you consider that Sears has service units nationwide staffed with Sears trained technicians...professional technicians specifically trained on Sears products, having the parts, tools and the equipment to insure that we meet our pledge to you..."we service what we sell."

SEARS CRAFTSMAN 5 H.P. CHIPPER-SHREDDER MODEL NOS. 247.799891  
Repair Parts

247.799892

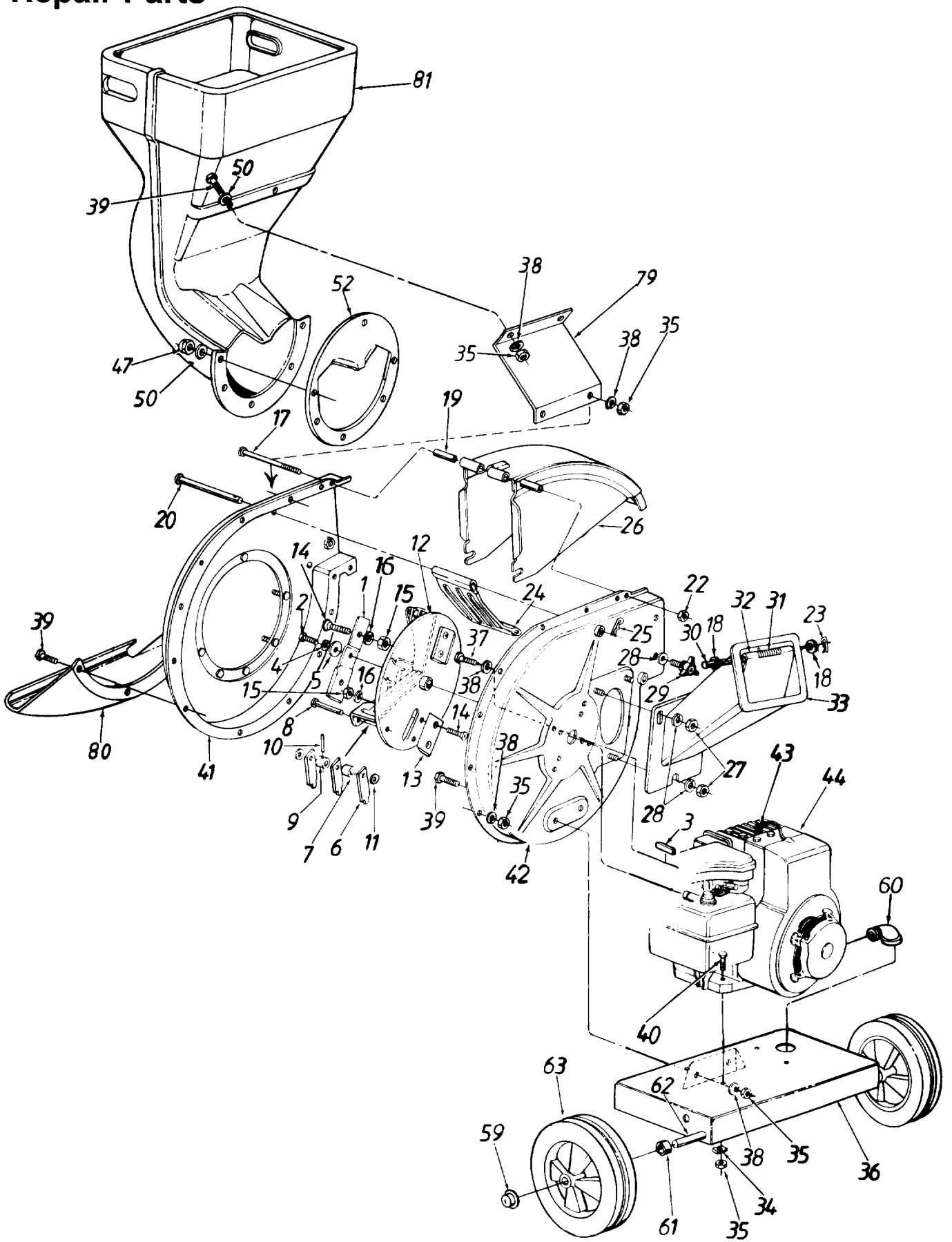



**SEARS CRAFTSMAN 5 H.P. CHIPPER-SHREDDER MODEL NOS. 247.799891  
247.799892**

## Repair Parts

KEY NO.	PART NO.	DESCRIPTION	KEY NO.	PART NO.	DESCRIPTION
1	742-0571	Blade	31	732-0542	Torsion Spring 1.14" Lg.
2	710-0818	Hex Patch Bolt 3/8-24 x 2" Lg. (Gr. 8) (247.799891)	32	781-0489	Chipper Door
	710-1254	Hex Patch Bolt 3/8-24 x 2.25" Lg. (247.799892)	33	781-0475	Chipper Chute Ass'y.
3	714-0114	Sq. Key 1/4 x 2.0" Lg. (247.799891)	34	736-0170	Spec. L-Wash. 5/16" I.D.
4	736-0217	L-Wash. 3/8" I.D. H.D.	35	712-3010	Hex Nut 5/16-18 Thd. (Gr. 5)
5	736-0247	FI-Wash. .406" I.D. x 1.25" O.D. Hdn.	36	781-0510A	Shredder Frame
6	11459B	Flail	37	710-0157	Hex Bolt 5/16-24 x .75" Lg.
7	711-0564	Flail Spacer	38	736-0119	L-Wash. 5/16" I.D.*
8	711-0833A	Clevis Pin .496" Dia.	39	710-3008	Hex Bolt 5/16-18 x .75" Lg. (Gr. 5)
9	711-0834	Flail Spacer w/.160" Dia. Hole	40	710-0442	Hex Bolt 5/16-18 x 1.15" Lg.*
10	715-0249	Spring Roll Pin 1.12" Lg.	41	681-0004	Flail Housing Ass'y.—L.H.
11	736-0192	FI-Wash. .531" I.D. x .94" O.D.	42	781-0474A	Flail Housing Ass'y.—R.H.
12	681-0002	Impeller Ass'y. (247.799891)†	43	735-0639	Spark Plug Boot
	681-0030	Impeller Ass'y. (247.799892)†	44	135212-0272-01	Engine—B&S 135212-0272-01 (247.799891)
13	781-0490	Chipper Blade		135212-0140-01	Engine—B&S 135212-0140-01 (247.799892)
14	710-1054	Flat Hd. Scr. 5/16-24 x .75" Lg.	45	747-0531A	Release Bar
15	712-0411	Hex Top L-Nut 5/16-24 (Gr. 5)	46	742-0546	Torsion Spring 1.06" Lg.
16	736-0119	L-Wash. 5/16" I.D.*	47	712-0429	Elastic Lock Nut 5/16-18 Thd.
17	710-0825	Hex Bolt 1/4-20 x 3.75" Lg.*	50	736-0264	FI-Wash. 5/16" I.D.
18	736-0142	FI-Wash. .281" I.D. x .50" O.D.	51	710-0542	Hex Bolt 5/16-18 x 8.38" Lg.
19	750-0793	Chute Hinge Spacer 1.66" Lg.	52	781-0521	Back-Up Plate
20	711-0835	Clevis Pin .5" Dia. x 4.62" Lg.	59	726-0214	Push Cap 5/8" Dia. Rod
22	712-0291	Hex Ctr. L-Nut 1/4-20 Thd.	60	737-0195	Drain Elbow
23	714-3010	Cotter Pin	61	750-0786	Spacer .64" I.D. x .38" Lg.
24	781-0457	Shredder Screen	62	738-0814	Shredder Axle
25	714-0149B	Internal Cotter Pin 3/8" Dia.	63	734-1600	Wheel Ass'y. Comp.
26	781-0480	Chute Deflector Ass'y.	79	781-0519	Hopper Support Brkt.
27	712-3010	Hex Nut 5/16-18 Thd. (Gr. 5)	80	781-0515	Front Support Brkt.
28	736-0242	Bell-Wash. .345" I.D. x .88"	81	731-1307	Leaf Hopper
29	720-0170	Hand Knob	—	764-0199A	Bag (Not Shown)
30	747-0744A	Chipper Door Rod	—	723-0400	Safety Glasses (Not Shown)
			—	770-7924H	Owner's Manual

†Incl. Ref. 1, 6, 7, 8, 9, 10, 11, 12, 13, 14

\*Common Hardware—May Be Purchased Locally.

**NOTE:** Specifications subject to change without notice or obligation.

**BRIGGS AND STRATTON 5 H.P. ENGINE MODEL NOS. 135212-0272-01  
135212-0140-01**

**Repair Parts**

REF. NO.	PART NO.	DESCRIPTION
55	494846	Housing-Rewind Starter
56	493824	Pulley-Rewind Starter
57	262594	Spring-Rewind Starter
58	280406	Rope-Rewind Starter Cut to Required Length.
59	396892	Insert-Starter Handle
60	393152	Handle-Rewind Starter
65	94686	Screw-Housing Mtg.
69	280973	Washer
69A	224322	Washer
373	92987	Nut-Hex.
456	224321	Retainer
459	492833	Pawl-Starter
461	262626	Pin-Spring
515	262625	Spring
608	495766	Starter Assy.-Rewind
1016	224278	Spacer

REF. NO.	PART NO.	DESCRIPTION
1	395990	Cylinder Assembly
22	97565	Bushing-Cylinder
3	*299819	Seal-Oil
23	297229	Flywheel-Magneto
24	222698	Key-Flywheel
37	222443	Guard-Flywheel
73	224632	Screen-Rotating
200	223886	Guide-Air
304	495759	Housing-Blower
305	94619	Screw-Blower Housing Mounting
307	94680	Screw-Sem
332	92284	Nut-Flywheel
333	397358	Armature Group
334	93414	Screw-Armature Mtg.
356	398808	Wire-Ground
363	19069	Flywheel Puller
455	224250	Cup-Starter
851	221798	Cable Term.-Ignition

\*Included in Gasket Set—Part No. 495603.

REF. NO.	PART NO.	DESCRIPTION
3	*299819	Seal-Oil
7	*272157	Gasket-Cylinder Head
9	*27549	Gasket-Valve Cover
12	*270080	Gasket-Crankcase (.015" Thick, Std.)
	*270125	Gasket-Crankcase (.005" Thick)
	*270126	Gasket-Crankcase (.009" Thick)
52	*271936	Gasket-Carburetor Mounting (2)
121	495606	Carburetor Overhaul Kit
163	*271935	Gasket-Air Cleaner Mounting
191	*272489	Gasket-Fuel Tank to Carb. Mtg.
358	495603	Gasket Set
394	*272538	Diaphragm

\* Included in Gasket Set—Part No. 495603.

• Included in Carburetor Overhaul Kit—Part No. 495606.

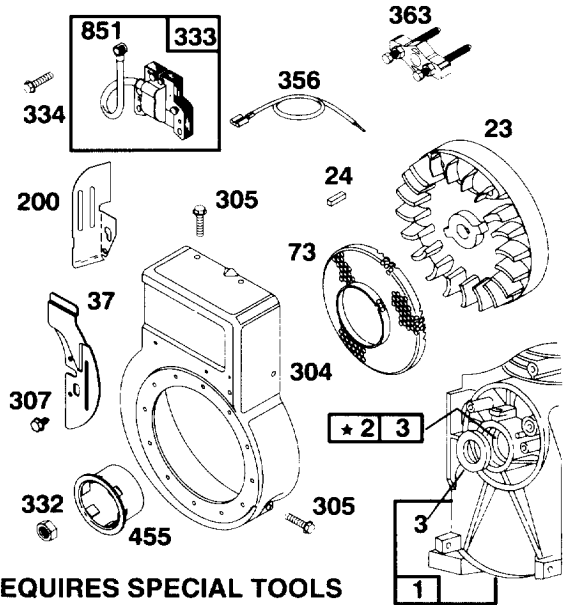
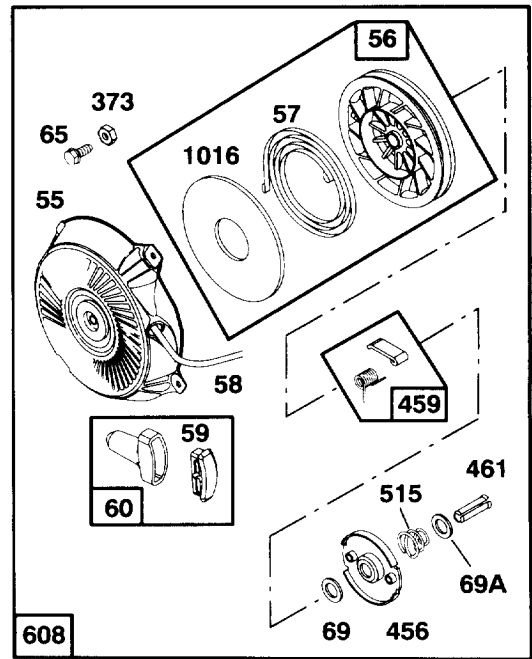

**\*REQUIRES SPECIAL TOOLS TO INSTALL. SEE REPAIR INSTRUCTION MANUAL.**

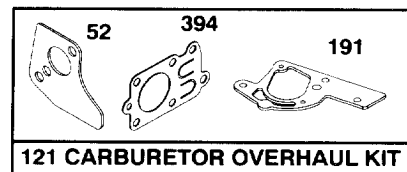
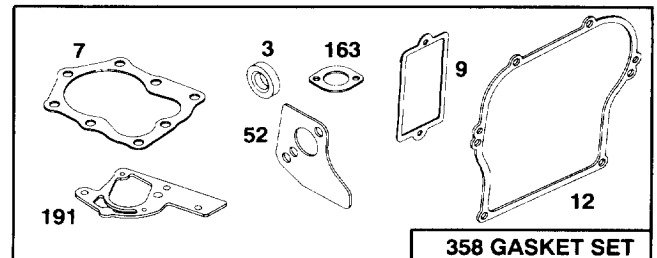

**BRIGGS AND STRATTON 5 H.P. ENGINE MODEL NOS. 135212-0272-01  
135212-0140-01**

# Repair Parts

REF. NO.	PART NO.	DESCRIPTION
52	*271936	Gasket-Carburetor Mounting (2)
90	495426	Carburetor Assembly
95	93499	Screw-Throttle Valve to Shaft
96	223793	Throttle-Carburetor
97	490048	Shaft and Lever-Throttle
108	491177	Valve & Shaft Group-Choke
118	231533	Valve-Needle
124	94616	Screw-Hex. Head
127	220352	Plug-Welch
127A	223789	Plug-Welch
149	26336	Spring-Needle Valve
152	260575	Spring-Throttle Adjustment
154	93527	Screw-Machine, Rd. Hd.
202	262270	Link-Throttle
203	280720	Bell Crank
205	231520	Screw-Shoulder
392	262328	Spring-Fuel Pump Diaphragm
394	•272538	Diaphragm
432	221377	Cap-Spring
433	93265	Pin-Diaphragm Cover
434	214021	Cover-Diaphragm
435	93141	Screw-Diaphragm Cover
611	391813	Fuel Pipe and Clip Assembly
634	271853	Washer-Throttle Shaft (Foam)
679	270382	Washer-Foam
680	221839	Washer-Brass
987	398970	Seal-Throttle Shaft

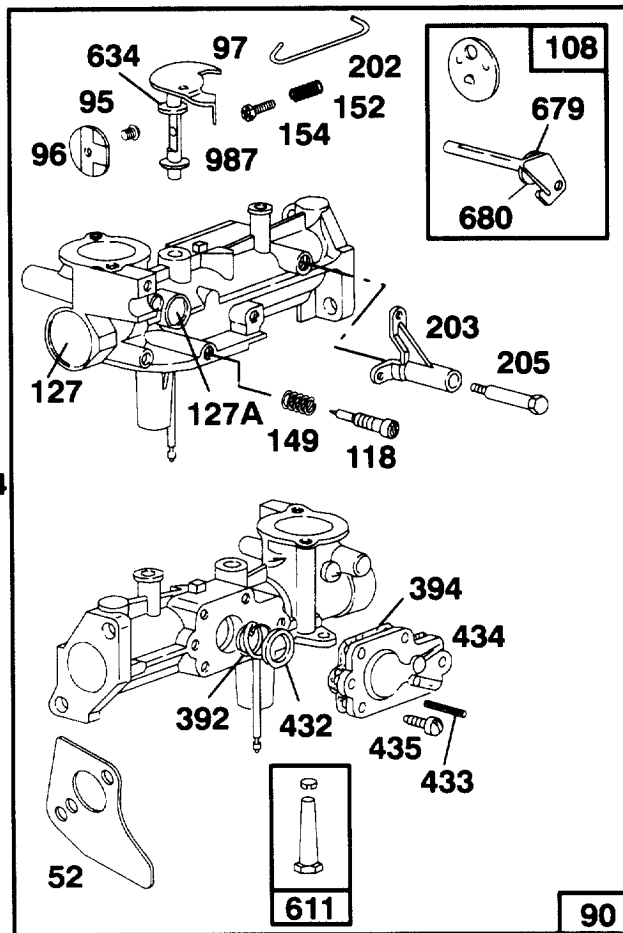

REF. NO.	PART NO.	DESCRIPTION
180	495405	Tank Assembly-Fuel
181	494559	Cap-Fuel Tank
190	94712	Screw-Fuel Tank
190A	94677	Screw-Fuel Tank Mounting (1-3/4" Long)
191	*272489	Gasket-Fuel Tank to Carb. Mtg.
204	222962	Bushing-Governor Lever (Flat)
209	262282	Spring-Governor
223	223455	Lever-Gov. Control
224	93491	Rivet-Gov. Control Lever Mounting
526	94659	Screw-Tank Bracket Mounting Sem
916	280321	Rack-Gear Control

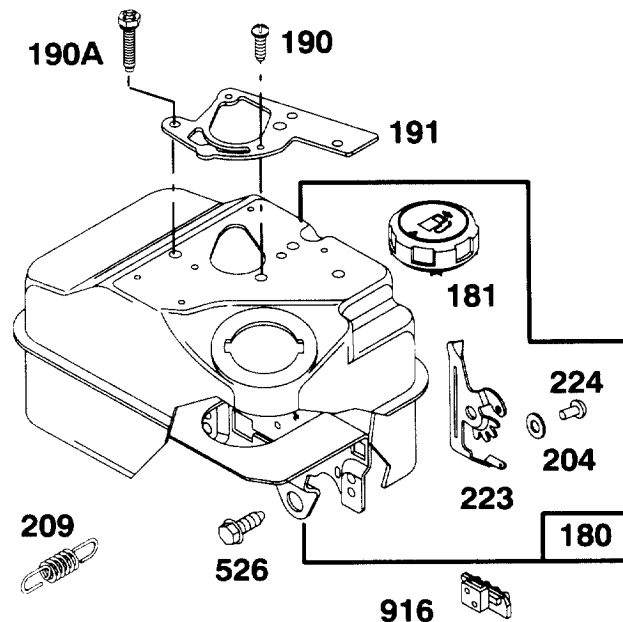

\* Included in Gasket Set—Part No. 495603.  
• Included in Carburetor Overhaul Kit—Part No. 495606.

**BRIGGS AND STRATTON 5 H.P. ENGINE MODEL NOS. 135212-0272-01  
135212-0140-01**

# Repair Parts

REF. NO.	PART NO.	DESCRIPTION
12	*270080	Gasket-Crankcase (.015" Thick, Std.)
	*270125	Gasket-Crankcase (.005" Thick)
	*270126	Gasket-Crankcase (.009" Thick)
18	493916	Cover Assy.-Crkscse.
19	495660	Bushing-Crankcase Cover
20	*298504	Seal-Oil
21	66768	Plug-Oil Filler
22	94682	Screw-Cover Mtg.
25	298904	Piston Assy. (Std.)
	298905	Piston Assembly (.010" O.S.)
	298906	Piston Assembly (.020" O.S.)
	298907	Piston Assembly (.030" O.S.)
		<b>PISTON RING SETS</b>
		<b>Note:</b> For Chrome Ring Set (Standard Size) Order No. 299742.
26	298982	Ring Set-Piston Std.
	298983	Ring Set-Piston (.010" O.S.)
	298984	Ring Set-Piston (.020" O.S.)
	298985	Ring Set-Piston (.030" O.S.)
27	26026	Lock-Piston Pin
28	298909	Pin Assy.-Piston (Standard)
	298908	Pin Assy.-Piston (.005" O.S.)
29	299430	Rod Assy.-Connecting
		<b>Note:</b> For Conn. Rod With .020" Under size Crankpin Bore Order No. 390459.
30	221890	Dipper-Conn. Rod
32	94745	Screw-Conn. Rod
45	260642	Tappet-Valve
46	212733	Gear-Cam
219	494845	Gear-Governor
220	221551	Washer-Thrust
227	490374	Lever Assy.-Governor
230	222450	Washer-Gov. Lever
562	92613	Bolt-Governor Lever
592	231082	Nut-Hex.
614	93306	Pin-Cotter
615	93307	Retainer-E-Ring
616	231077	Crank-Governor

REF. NO.	PART NO.	DESCRIPTION
163	*271935	Gasket-Air Cleaner Mounting
298	261409	Locknut-Muffler
299	393368	Muffler-Exhaust
346	93705	Screw-Sem
535	491435	Element-Air Cleaner
536	494279	Cleaner-Air
676	393758	Deflector-Exhaust
725	223867	Shield-Heat
966	492797	Base-Air Cleaner
967	491588	Filter-Air Cleaner
968	495357	Cover-Air Cleaner
969	490073	Screw-Air Cleaner
971	94018	Screw-Hex. Hd.

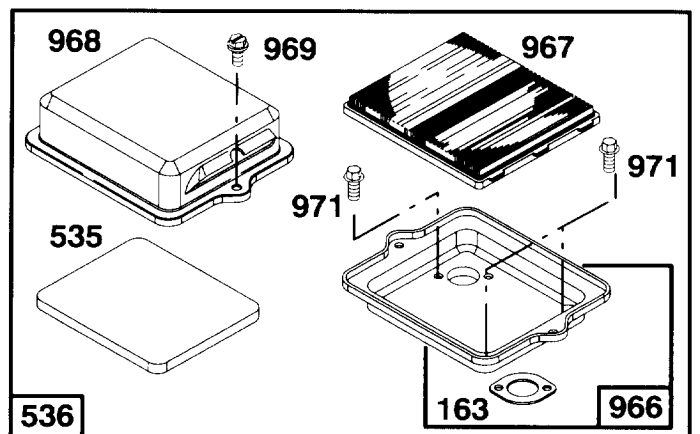
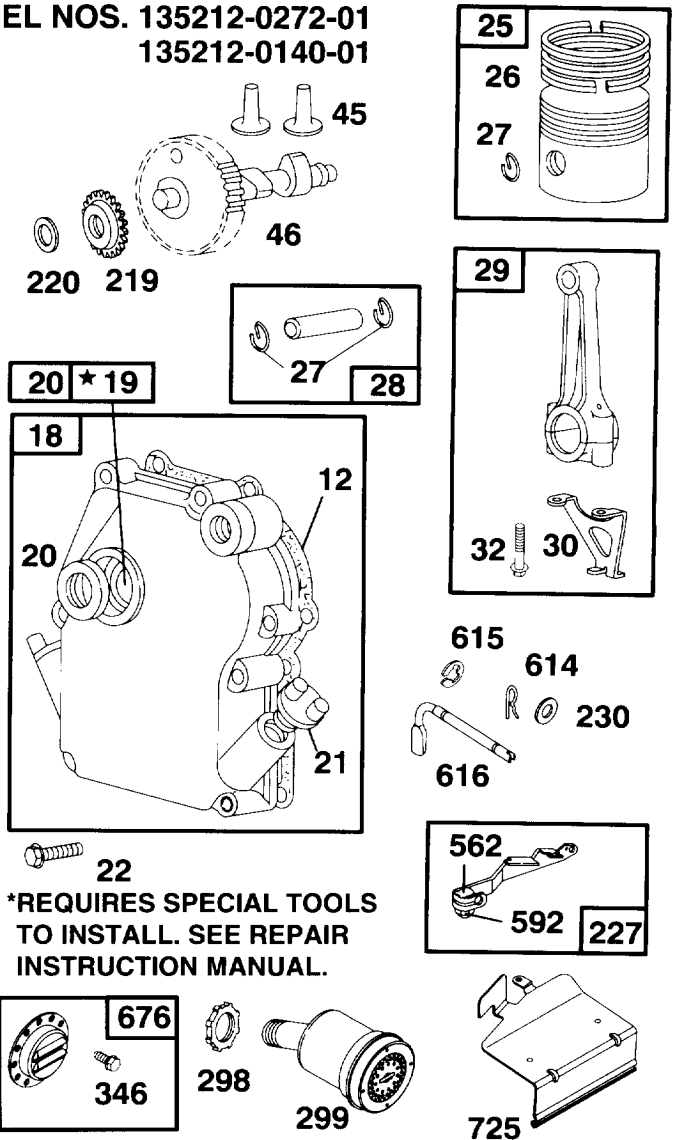

**SPARK ARRESTING MUFFLER ASSEMBLY 392390 (Optional Equipment)**

Consists of the following:

- 392154 Screen (1 required)
- 223372 Deflector (1 required)
- 93705 Screw (4 required)

\* Included in Gasket Set—Part No. 495603.

**BRIGGS AND STRATTON 5 H.P. ENGINE MODEL NOS. 135212-0272-01  
135212-0140-01**

# Repair Parts

REF. NO.	PART NO.	DESCRIPTION
1	395990	Cylinder Assembly
5	214040	Head-Cylinder
7	*272157	Gasket-Cylinder Head
8	495774	Breather Assy.
9	*27549	Gasket-Valve Cover
10	94621	Screw-Breather Mtg.
11	66578	Grommet-Breather
13	94221	Screw-Cylinder Head (2-3/32" Long)
14	94679	Screw-Cylinder Head (2-15/32" Long)
15	94387	Plug-Pipe
16	495649	Crankshaft (135212-0272-01)
	495845	Crankshaft (135212-0140-01)
		<b>Note:</b> To Replace Crankshaft Gear Pin Order Part No. 230978.
33	211119	Valve-Exhaust
34	261044	Valve-Intake
35	260552	Spring-Intake Valve
36	26478	Spring-Exhaust Valve
40	93312	Retainer-Intake Valve and Exhaust Spring
306	221511	Shield-Cylinder
307	94680	Screw-Cylinder Shield
308	224738	Cover-Cylinder Head
337	802592	Plug-Spark
383	89838	Wrench-Spark Plug
527	223786	Clamp-Breather Tube
528	231550	Tube-Breather
529	67838	Grommet-Breather Tube
552	231079	Bushing-Gov. Crank
635	66538	Elbow-Spark Plug
741	261696	Gear-Timing
869	211787	Seat-Int. Valve (Std.)
870	211172	Seat-Ex. Valve (Std.)
871	262001	Guide-Exhaust Valve
		<b>Note:</b> 63709 Guide-Intake Valve

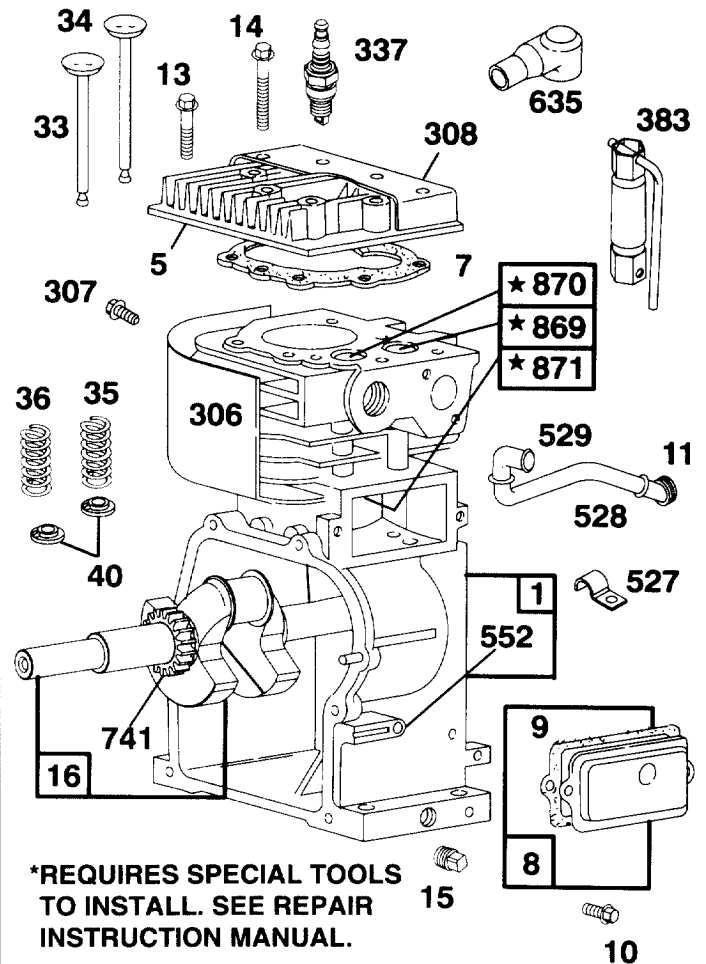

**\*REQUIRES SPECIAL TOOLS TO INSTALL. SEE REPAIR INSTRUCTION MANUAL.**

REF. NO.	PART NO.	DESCRIPTION
153	490589	Screw and Collar
201	262280	Link-Governor
208	262279	Rod-Speed Control
216	262359	Link-Choke
222	490649	Panel-Control
256	223813	Crank-Bell
284	94620	Screw-Hex. Head
414	220982	Washer
441	224240	Bracket-Oil Fill
467	280715	Knob-Control
523	494416	Dipstick and Cap Assy.
524	*271485	Seal-Oil Filler Tube
525	280578	Tube-Oil Filler
542	93572	Screw
621	396847	Switch-Stop
779	262570	Link-Speed Control
842	*270920	Seal-Oil Filler Tube
847	494417	Tube and Dipstick Assy.
995	223887	Lever-Bracket Assy.
1012	490507	Retainer-Link

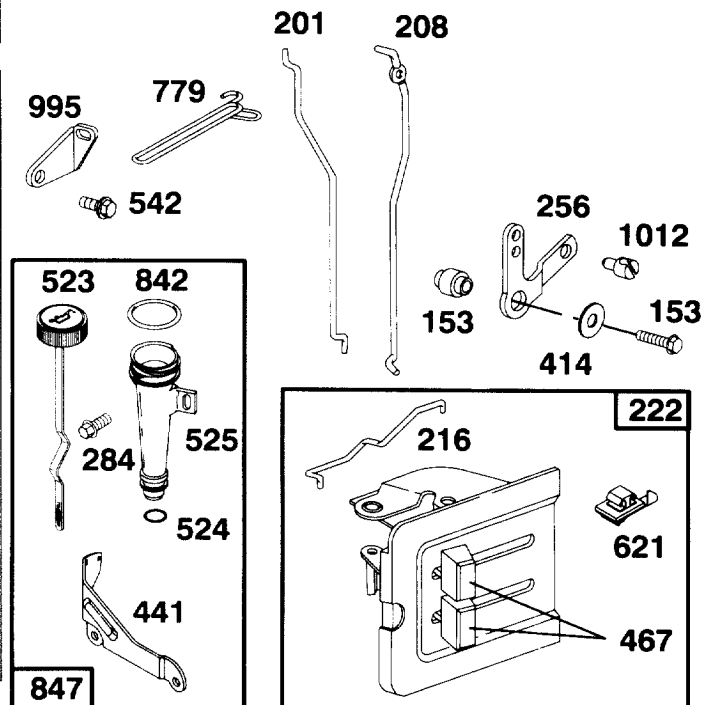

\* Included in Gasket Set—Part No. 495603.