

IMAGE[®] SE 7.8

Patent Pending

Model No. IMTL07800

Serial No. _____

Write the serial number in the space above for future reference.

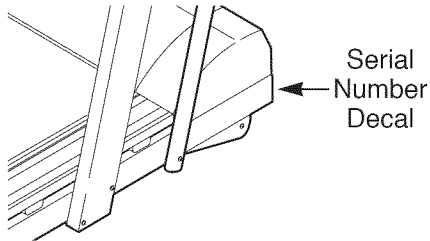

USER'S MANUAL

QUESTIONS?

As a manufacturer, we are committed to providing complete customer satisfaction. If you have questions, or if there are missing parts, we will guarantee complete satisfaction through direct assistance from our factory.

TO AVOID UNNECESSARY DELAYS, PLEASE CALL DIRECT TO OUR TOLL-FREE CUSTOMER HOT LINE. The trained technicians on our Customer Hot Line will provide immediate assistance, free of charge to you.

CUSTOMER HOT LINE:
1-800-999-3756
Mon.-Fri., 6 am-6 pm MST

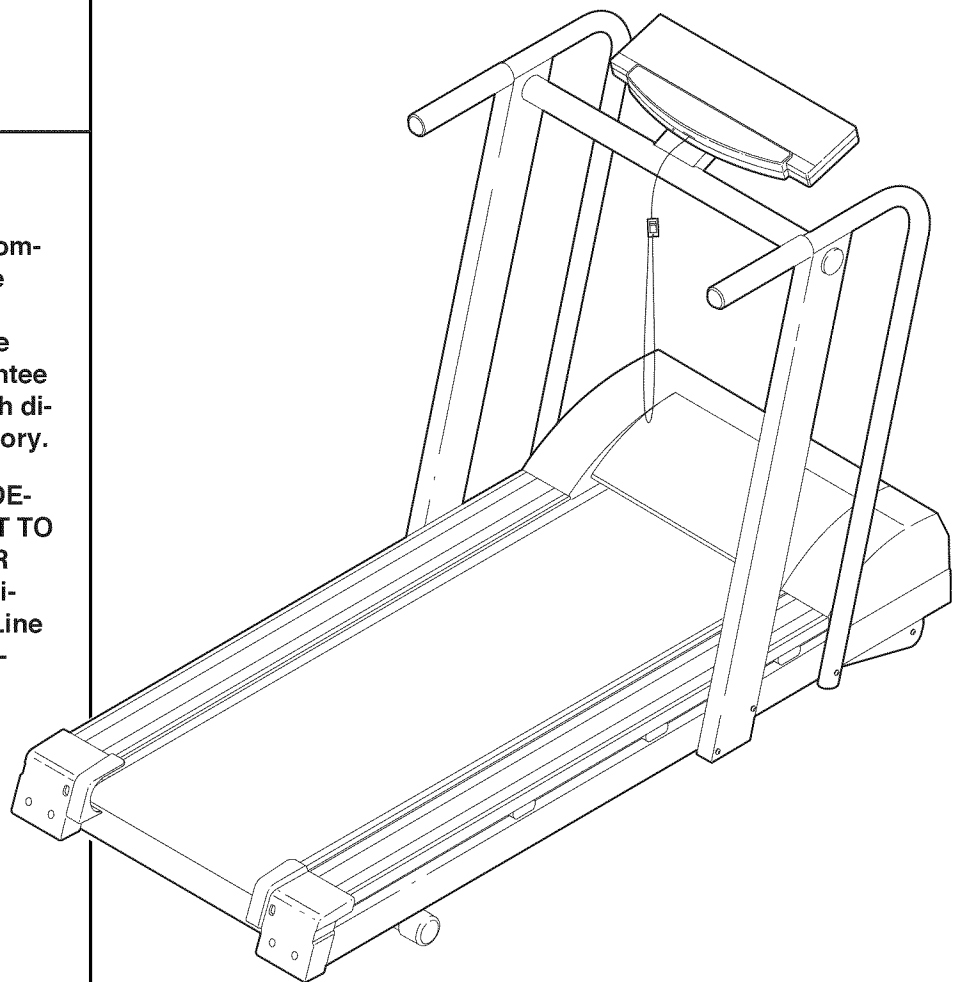

⚠ CAUTION

Read all precautions and instructions in this manual before using this equipment. Save this manual for future reference.



Visit our website at

www.imagefitness.com

new products, prizes,
fitness tips, and much more!

TABLE OF CONTENTS

IMPORTANT PRECAUTIONS	2
BEFORE YOU BEGIN	4
ASSEMBLY	5
HOW TO USE THE HEART RATE MONITOR	6
OPERATION AND ADJUSTMENT	7
TROUBLE-SHOOTING	12
CONDITIONING GUIDELINES	15
ORDERING REPLACEMENT PARTS	Back Cover
LIMITED WARRANTY	Back Cover

Note: An EXPLODED DRAWING and PART LIST are attached in the center of this manual.

IMPORTANT PRECAUTIONS

▲ WARNING: To reduce the risk of burns, fire, electric shock, or injury to persons, read the following important precautions and information before operating the treadmill.

1. It is the responsibility of the owner to ensure that all users of this treadmill are adequately informed of all warnings and precautions.
2. Use the treadmill only as described in this manual.
3. Place the treadmill on a level surface, with eight feet of clearance behind it. Do not place the treadmill on any surface that blocks air openings. To protect the floor or carpet from damage, place a mat under the treadmill.
4. Keep the treadmill indoors, away from moisture and dust. Do not put the treadmill in a garage or covered patio, or near water.
5. Do not operate the treadmill where aerosol products are used or where oxygen is being administered.
6. Keep children under the age of 12 and pets away from the treadmill at all times.
7. The treadmill should not be used by persons weighing more than 250 pounds.
8. Never allow more than one person on the treadmill at a time.
9. Wear appropriate exercise clothing when using the treadmill. Do not wear loose clothing that could become caught in the treadmill. Athletic support clothes are recommended for both men and women. Always wear athletic shoes. Never use the treadmill with bare feet, wearing only stockings, or in sandals.
10. When connecting the power cord (see page 7), plug the power cord into a surge protector (not included) and plug the surge protector into a grounded circuit capable of carrying 15 or more amps. No other appliance should be on the same circuit.
11. Use only a single-outlet surge suppressor that is UL 1449 listed as a transient voltage surge suppressor (TVSS). The surge suppressor must have a UL suppressed voltage rating of 400 volts or less and a minimum surge dissipation of 450 joules. The surge suppressor must be electrically rated for 120 volts AC and 15 amps. To purchase a surge suppressor, see your local IMAGE dealer or call 1-800-999-3756 and order part number 146148.
12. Keep the power cord and the surge suppressor away from heated surfaces.

13. Never move the walking belt while the power is turned off. Do not operate the treadmill if the power cord or plug is damaged, or if the treadmill is not working properly. (See BEFORE YOU BEGIN on page 4 if the treadmill is not working properly.)
14. Never start the treadmill while you are standing on the walking belt. Always hold the handrails while using the treadmill.
15. The treadmill is capable of high speeds. Adjust the speed in small increments to avoid sudden jumps in speed.
16. The heart rate monitor is not a medical device. Various factors, including the user's movement, may affect the accuracy of heart rate readings. The heart rate monitor is intended only as an exercise aid in determining heart rate trends in general.
17. Never leave the treadmill unattended while it is running. Always remove the key, unplug the power cord and move the on/off switch to

the off position when the treadmill is not in use. (See the drawing on page 4 for the location of the on/off switch.)

18. Inspect and tighten all parts of the treadmill every three months.
19. Never drop or insert any object into any opening.
20. **DANGER:** Always unplug the power cord immediately after use, before cleaning the treadmill, and before performing the maintenance and adjustment procedures described in this manual. Never remove the motor hood unless instructed to do so by an authorized service representative. Servicing other than the procedures in this manual should be performed by an authorized service representative only.
21. This treadmill is intended for in-home use only. Do not use this treadmill in any commercial, rental, or institutional setting.

⚠ WARNING: Before beginning this or any exercise program, consult your physician. This is especially important for persons over the age of 35 or persons with pre-existing health problems. Read all instructions before using. ICON assumes no responsibility for personal injury or property damage sustained by or through the use of this product.

SAVE THESE INSTRUCTIONS

BEFORE YOU BEGIN

Thank you for selecting the new IMAGE® SE 7.8 treadmill. The IMAGE SE 7.8 treadmill combines advanced technology with innovative design to let you enjoy an effective form of cardiovascular exercise in the convenience and privacy of your home.



For your benefit, read this manual carefully before using the treadmill. If you have additional questions, please call our Customer Service Department toll-free at 1-800-999-3756, Monday through Friday, 6 a.m.

until 6 p.m. Mountain Time (excluding holidays). To help us assist you, please note the product model number and serial number before calling. The model number of the treadmill is IMTL07800. The serial number can be found on a decal attached to the treadmill (see the front cover of this manual for the location).

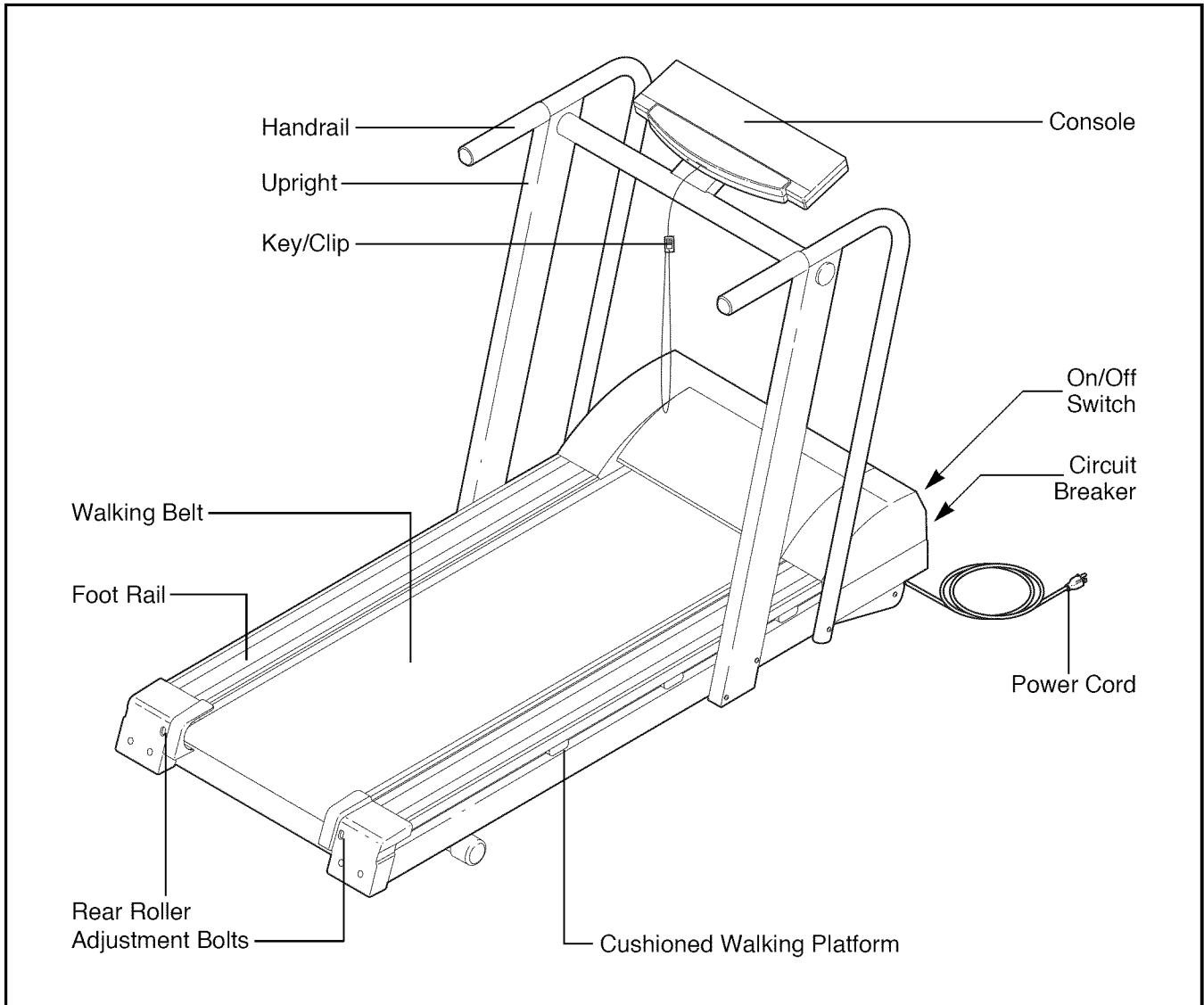
Before reading further, please familiarize yourself with the parts that are labeled in the drawing below.



ASSEMBLY

Assembly requires two people. Set the treadmill in a cleared area and remove all packing materials. Do not dispose of the packing materials until assembly is completed. **Assembly requires the included allen wrench** , **and your own adjustable wrench** .

Note: The underside of the treadmill walking belt is coated with high-performance lubricant. During shipping, a small amount of lubricant may be transferred to the top of the walking belt or the shipping carton. This is a normal condition and does not affect treadmill performance. If there is lubricant on top of the walking belt, simply wipe off the lubricant with a soft cloth and a mild, non-abrasive cleaner.

1. With the help of a second person, carefully raise the Uprights (80) until the treadmill is in the position shown. Note: Be careful not to damage the Hood (85) with the handrails as you raise the Uprights.

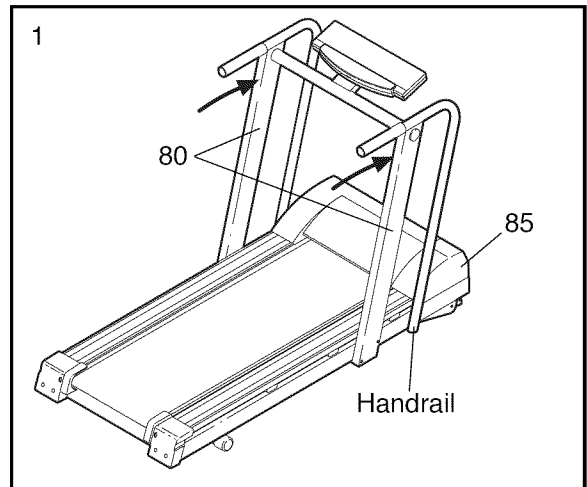

2. Finger tighten an Upright Bolt (7) into the lower end of the right handrail.

Next, hold an Upright Spacer (11) inside the lower end of the right Upright (80). Insert an Upright Bolt (7) through the Upright and the Upright Spacer. Reach under the treadmill and finger tighten a Nut (12) onto the Upright Bolt.

Repeat this step on the left side of the treadmill (not shown).

Tighten all three Upright Bolts (7) on each side of the treadmill.

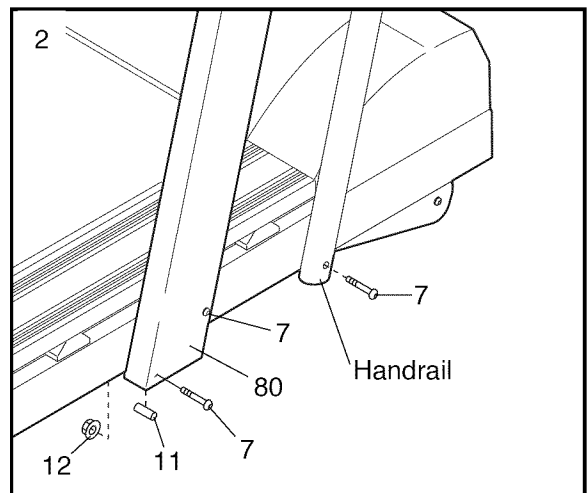

3. **Make sure that all parts are tightened before you use the treadmill.** Keep the included allen wrench in a secure place. The allen wrench is used to adjust the walking belt (see pages 12 and 13). To protect the floor or carpet from damage, place a mat under the treadmill.

HOW TO USE THE HEART RATE MONITOR

HOW TO PUT ON THE HEART RATE MONITOR

The heart rate monitor consists of two components: the chest strap and the sensor unit (see the drawing below). Insert the tab on one end of the chest strap through the hole in one end of the sensor unit. Press the end of the sensor unit under the buckle on the chest strap. The tab should be almost flush with the front of the sensor unit.

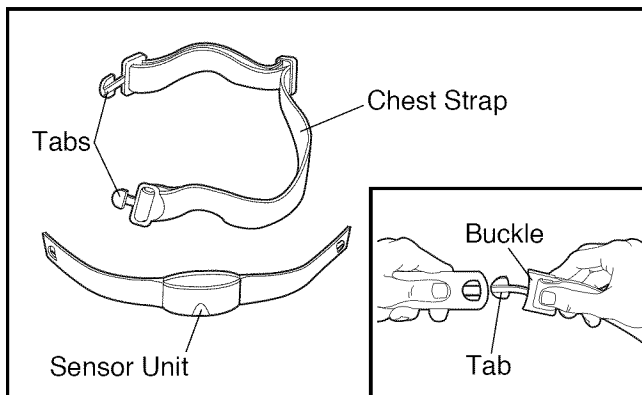

Next, wrap the heart rate monitor around your chest and attach the other end of the chest strap to the sensor unit. Adjust the length of the chest strap, if necessary. The heart rate monitor

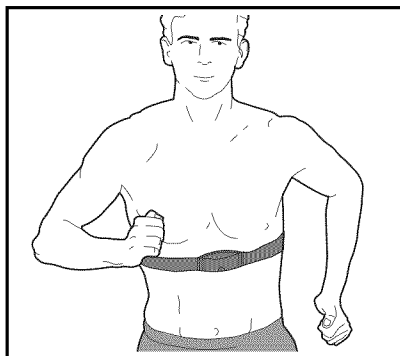

should be under your clothing, tight against your skin, and as high under the pectoral muscles or breasts as is comfortable. Make sure that the logo on the sensor unit is facing forward and is right-side-up.

Pull the sensor unit away from your body a few inches and locate the two electrode areas on the inner side. The electrode areas are the areas covered by shallow ridges. Using saline solution such as saliva or contact lens solution, wet both electrode areas. Return the sensor unit to a position against your chest.

HEART RATE MONITOR CARE AND MAINTENANCE

- Thoroughly dry the heart rate monitor after each use. The heart rate monitor is activated when the electrode areas are wetted and the heart rate monitor is put on; the heart rate monitor shuts off when it is removed and the electrode areas are dried. If the heart rate monitor is not dried after each use, it may remain activated longer than necessary, draining the battery prematurely.
- Store the heart rate monitor in a warm, dry place. Do not store the heart rate monitor in a plastic bag or other container that may trap moisture.
- Do not expose the heart rate monitor to direct sunlight for extended periods of time; do not expose it to temperatures above 122° Fahrenheit (50° Celsius) or below 14° Fahrenheit (-10° Celsius).
- Do not excessively bend or stretch the sensor unit when using or storing the heart rate monitor.
- Clean the sensor unit using a damp cloth—never use alcohol, abrasives, or chemicals. The chest strap may be hand washed and air dried.

HEART RATE MONITOR TROUBLE-SHOOTING

The instructions on the following pages explain how the heart rate monitor is used with the console. If the heart rate monitor does not function properly, try the steps below.

- Make sure that the heart rate monitor is under your clothing, tight against your skin, and as high under the pectoral muscles or breasts as is comfortable. The logo on the sensor unit must be facing forward and be right-side-up. Note: If the heart rate monitor does not function when positioned as described, try moving it slightly lower or higher on your chest.
- Use saline solution such as saliva or contact lens solution to wet the two electrode areas on the sensor unit. If heart rate readings do not appear until you begin perspiring, re-wet the electrode areas.
- As you walk or run on the treadmill, position yourself near the center of the walking belt. **For the console to display heart rate readings, the user must be within arm's length of the console.**
- The heart rate monitor is designed to work with people who have normal heart rhythms. Heart rate reading problems may be caused by medical conditions such as premature ventricular contractions (pvc's), tachycardia bursts, and arrhythmia.
- The operation of the heart rate monitor can be affected by magnetic interference caused by high power lines or other sources. If it is suspected that this is a problem, try relocating the treadmill.
- The CR2032 battery may need to be replaced (see page 14).

OPERATION AND ADJUSTMENT

THE PERFORMANT LUBE™ WALKING BELT

Your treadmill features a walking belt coated with PERFORMANT LUBE™, a high-performance lubricant. **IMPORTANT: Never apply silicone spray or other substances to the walking belt or the walking platform. Such substances will deteriorate the walking belt and cause excessive wear.**

HOW TO PLUG IN THE POWER CORD

⚠ DANGER: Improper connection of the equipment-grounding conductor can result in an increased risk of electric shock. Check with a qualified electrician or serviceman if you are in doubt as to whether the product is properly grounded. Do not modify the plug provided with the product—if it will not fit the outlet, have a proper outlet installed by a qualified electrician.

Your treadmill, like any other type of sophisticated electronic equipment, can be seriously damaged by sudden voltage changes in your home's power. Voltage surges, spikes, and noise interference can result from weather conditions or from other appliances being turned on or off. **To decrease the possibility of your treadmill being damaged, always use a surge suppressor with your treadmill (see drawing 1 at the right).**

To purchase a surge suppressor, see your local IMAGE dealer or call 1-800-999-3756 and order part number 146148. Use only a single-outlet surge suppressor that is UL 1449 listed as a transient voltage surge suppressor (TVSS). The surge suppressor must have a UL suppressed voltage rating of 400 volts or less and a minimum surge dissipation of 450 joules. The surge suppressor must be electrically rated for 120 volts AC and 15 amps.

This product must be grounded. If it should malfunction or break down, grounding provides a path of least resistance for electric current to reduce the risk of electric shock. This product is equipped with a cord having an equipment-grounding conductor and a grounding plug. **Plug the power cord into a surge suppressor, and plug the surge suppressor into an appropriate outlet that is properly installed and grounded in accordance with all local codes and ordinances. Important: The treadmill is not compatible with GFCI-equipped outlets.**

This product is for use on a nominal 120-volt circuit, and has a grounding plug that looks like the plug illustrated in drawing 1 below. A temporary adapter that looks like the adapter illustrated in drawing 2 may be used to connect the surge suppressor to a 2-pole receptacle as shown in drawing 2 if a properly grounded outlet is not available.

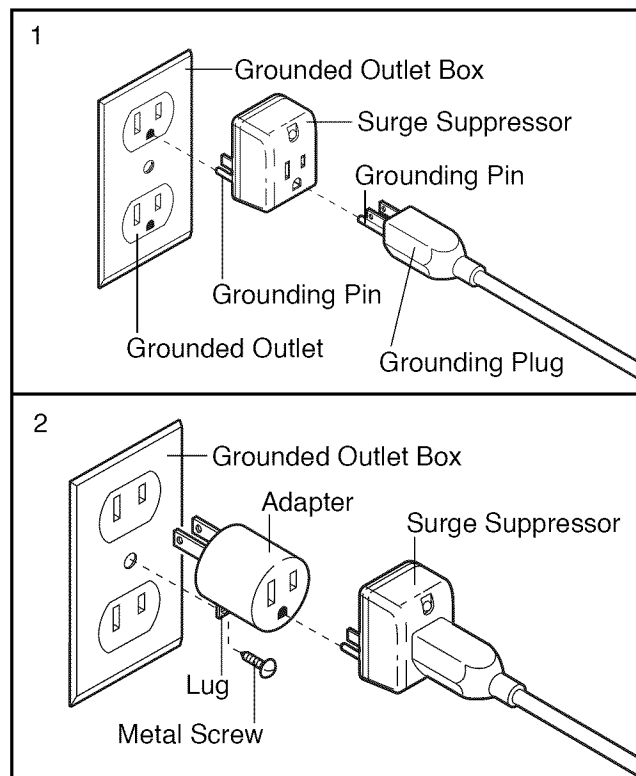

The temporary adapter should be used only until a properly grounded outlet (drawing 1) can be installed by a qualified electrician.

The green-colored rigid ear, lug, or the like extending from the adapter must be connected to a permanent ground such as a properly grounded outlet box cover. Whenever the adapter is used it must be held in place by a metal screw. **Some 2-pole receptacle outlet box covers are not grounded. Contact a qualified electrician to determine if the outlet box cover is grounded before using an adapter.**

CONSOLE DIAGRAM

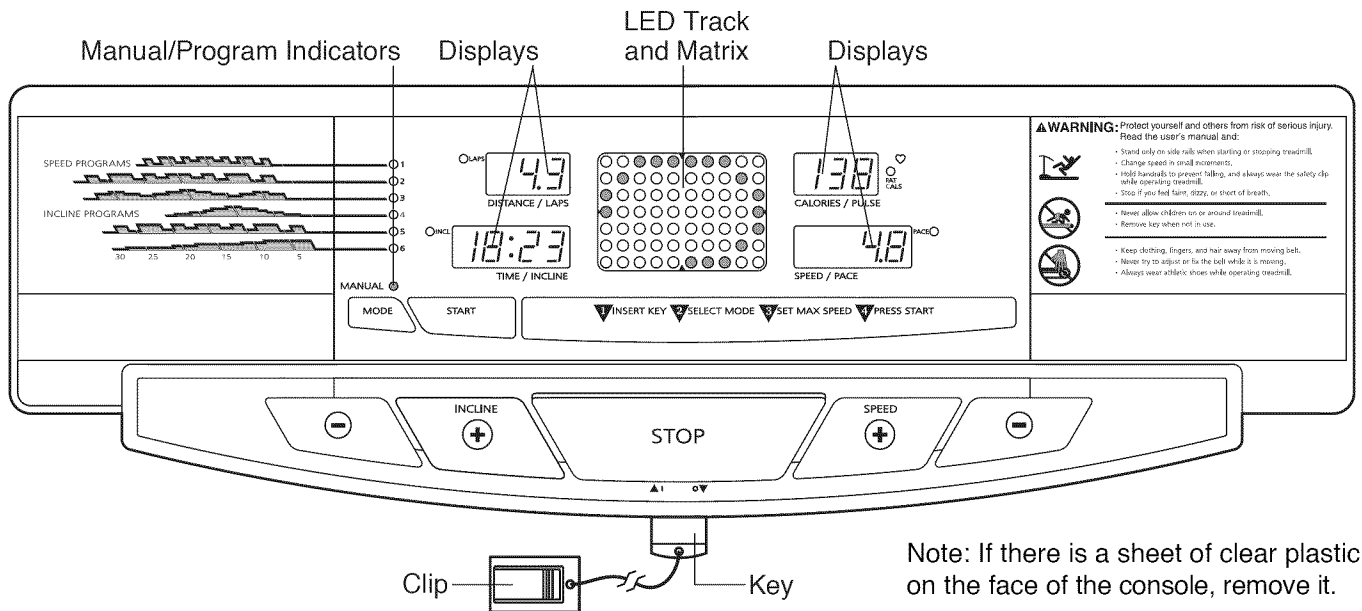

Note: If there is a sheet of clear plastic on the face of the console, remove it.

CAUTION: Before operating the console, read the following precautions.

- Do not stand on the walking belt when turning on the power.
- Always wear the clip (see the drawing above) while operating the treadmill. If the key is pulled from the console, the walking belt will automatically stop.
- Adjust the speed in small increments to avoid sudden jumps in speed.
- To reduce the possibility of electric shock, keep the console dry. Avoid spilling liquids on the console, and place only a sealed water bottle in the water bottle holder.

FEATURES OF THE CONSOLE

The treadmill console offers an impressive array of features to help you get the most from your workouts. When the manual mode is selected, the speed and incline of the treadmill can be changed with a touch of a button. As you exercise, the LED track and the four displays will provide continuous exercise feedback. In addition, the console offers six workout programs. Three programs automatically control the speed of the treadmill and three programs control the incline of the treadmill as they guide you through effective workouts.

GETTING STARTED

1 Attach the clip to the waistband of your clothes.

Stand on the foot rails of the treadmill. Find the clip attached to the key (see the drawing above), and slide the clip onto the waistband of your clothes. Next, insert the key fully into the console. **Test the clip by carefully taking a few steps backward until the key is pulled from the console. If the key is not pulled from the console, adjust the position of the clip as needed.** Then, remove the key from the console.

2 Plug in the power cord.

See page 7.

3 Move the on/off switch to the on position.

Locate the on/off switch on the treadmill near the power cord. Move the switch to the on position.

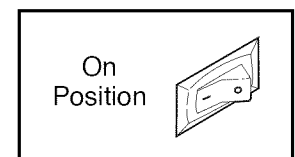

4 Insert the key fully into the console.

When the key is inserted, the four displays and various indicators on the console will light.

Note: The console can display speed and distance in either miles or kilometers (see SPEED/PACE display on page 9). For simplicity, all instructions in this manual refer to miles.

HOW TO USE THE MANUAL MODE

1 Insert the key into the console.

See GETTING STARTED on page 8.

2 Select the manual mode.

When the key is inserted, the manual mode will automatically be selected, as shown by the manual indicator. If you have selected a workout program, press the mode button repeatedly until the manual indicator lights.

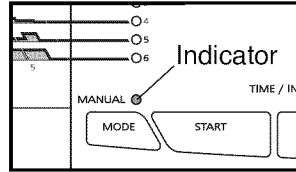

3 Put on the heart rate monitor if desired.

For the CALORIES/PULSE display to show your heart rate, the heart rate monitor must be worn. To put on the heart rate monitor, see HOW TO USE THE HEART RATE MONITOR on page 6.

4 Press the START button and adjust the speed of the walking belt.

A moment after the START button is pressed, the walking belt will begin to move. Hold the handrails and carefully begin walking.

As you exercise, change the speed of the walking belt as desired by pressing the SPEED buttons. Each time one of the buttons is pressed, the speed will change by 0.1 mph. The buttons can be held down to change the speed setting quickly. Note: It may take a few seconds for the walking belt to reach the selected speed setting.

To stop the walking belt, press the STOP button. The TIME/INCLINE display will begin to flash. To restart the walking belt, press the START button.

5 Adjust the incline of the treadmill as desired

To change the incline of the treadmill, press the INCLINE buttons. Each time one of the buttons is pressed, the incline will change by 0.5%. The buttons can be held down to change the incline quickly. Note: It may take a few seconds for the treadmill to reach the selected incline setting.

6 Follow your progress with the LED track and the four displays.

The LED Track—When the manual mode is selected, the LED matrix will display a track. The track represents a distance of 1/4 mile. As you exercise, the indicators around the track will light one at a time until you have completed 1/4 mile. A new lap will then begin.

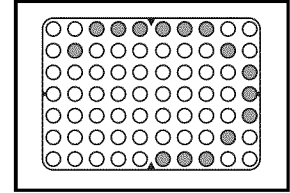

DISTANCE/LAPS

display—This display shows the distance that the walking belt has moved and the number of 1/4-mile laps you have completed. The display will alternate between one number and the other every seven seconds; the indicator will light when the number of laps is shown.

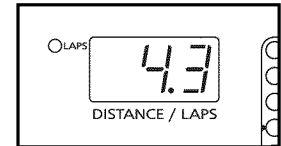

TIME/INCLINE

display—This display shows the elapsed time and the incline level of the treadmill. The display will alternate between one number and the other every seven seconds; the indicator will light when the incline is shown. Note: When a workout program is selected, the display will show the time remaining in the program.

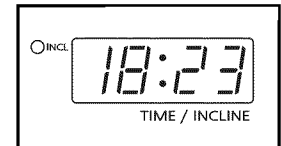

SPEED/PACE

display—This display shows the speed of the walking belt and your current pace (pace is measured in minutes per mile). Every seven seconds, the display will change from one number to the other; the indicator will light when your pace is shown.

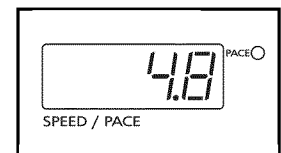

Note: The console can display distance, speed, and pace in either miles or kilometers. To see which unit of measurement is selected, hold down the STOP button while inserting the key into the console. An "E," for english miles, or an "M," for metric kilometers, will appear in the CALORIES/PULSE display. If you want to change the unit of measurement, press the SPEED Δ button. Then, remove and reinsert the key.

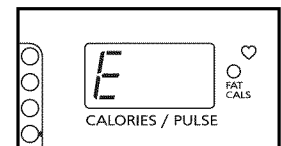

CALORIES/PULSE display—This display shows the approximate numbers of calories and fat calories you have burned (see FAT BURNING on page 15). Every seven seconds, the display will change from one number to the other; the indicator will light when the number of fat calories is shown. This display will also show your heart rate when the heart rate monitor is worn; the heart-shaped indicator will light when your heart rate is shown.

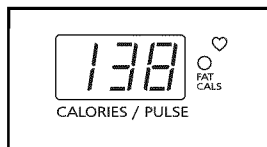

2 Press the MODE button to select the desired workout program.

When the key is inserted, the manual mode will be selected, as shown by the manual indicator. To select one of the workout programs, press the mode button repeatedly until one of the three speed program indicators or one of the three incline program indicators lights.

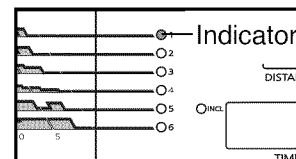

7 When you are finished exercising, press the STOP button and remove the key.

Step onto the foot rails, press the STOP button, and remove the key from the console. Keep the key in a secure place.

In addition, move the on/off switch to the off position and unplug the power cord.

Note: The graphs on the left side of the console show how the speed or incline of the treadmill will change during the programs. During program 4, for example, the graph shows that the incline will gradually increase during the first half of the program and then gradually decrease during the last half.

3 Set a maximum speed or incline setting.

If you selected a speed program, a number will flash in the SPEED/PACE display. This number is the maximum speed that the walking belt will reach during the selected program. If you want to change the maximum speed setting, press the SPEED Δ button. The maximum speed setting can be from 4 mph to 10 mph. If the setting is increased, the difficulty level of the entire program will increase. If the setting is decreased, the difficulty level of the entire program will decrease.

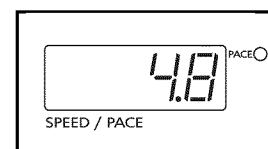

If you selected an incline program, a number will flash in the TIME/INCLINE display. This number is the maximum incline that the treadmill will reach during the selected program. If you want to change the maximum incline setting, press the INCLINE Δ button. The maximum incline setting can be from 4.5% to 10%. If the setting is increased, the difficulty level of the entire program will increase. If the setting is decreased, the difficulty level of the entire program will decrease.

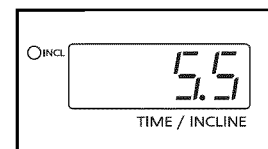

HOW TO USE WORKOUT PROGRAMS

The three speed programs automatically control the speed of the treadmill as they guide you through effective workouts; the three incline programs automatically control the incline of the treadmill. Follow the steps below to use a workout program.

1 Insert the key into the console.

See GETTING STARTED on page 8.

4 Put on the heart rate monitor if desired.

For the CALORIES/PULSE display to show your heart rate, the heart rate monitor must be worn. To put on the heart rate monitor, see HOW TO USE THE HEART RATE MONITOR on page 6.

5 Press the START button to start the program

A moment after the START button is pressed, the walking belt will begin to move. (If an incline program is selected, the treadmill will also adjust to the first incline setting for the program, unless it is already at the first setting.) Hold the handrails and carefully begin walking.

Each program consists of twenty or thirty, one-minute periods. (The length of the program is shown in the TIME/INCLINE display.) If a speed program is selected, one speed setting is programmed for each period; if an incline program is selected, one incline setting is programmed for each period.

The speed or incline settings for the program you have selected will be shown in the LED matrix. The speed or incline setting for the first period will be shown in the flashing CURRENT PERIOD column. The settings for the next seven periods will be shown in the seven columns to the right.

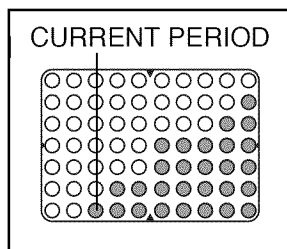

When only three seconds remain in the first period of the program, both the CURRENT PERIOD column and the column to the right will flash and three tones will sound. All speed or incline settings will then move one column to the left. The setting for the second period will then be shown in the CURRENT PERIOD column and the speed or incline of the treadmill will automatically adjust to the second setting.

If a speed program is selected, the incline of the treadmill can be changed during the program with the INCLINE buttons. If an incline program is selected, the speed of the treadmill can be changed with the SPEED buttons.

The program will continue until the speed or incline setting for the last period is shown in the CURRENT PERIOD column and the TIME/INCLINE display counts down to zero. The walking belt will then slow to a stop.

If the program is too easy or too difficult, the intensity of the program can be adjusted. If a speed program is selected, press the SPEED buttons to adjust the maximum speed setting; if an incline program is selected, press the INCLINE buttons to adjust the maximum incline setting (see step 3 on page 10).

To stop the program for a moment, press the STOP button. The displays will pause and the TIME/INCLINE display will begin to flash. To restart the program, press the START button. To end the program at any time, hold down the STOP button for two seconds. The MANUAL mode will then be selected.

6 Follow your progress with the four displays.

See step 6 on page 9.

7 When the program is completed, remove the key.

Step onto the foot rails and remove the key from the console. Keep the key in a secure place. In addition, move the on/off switch to the off position and unplug the power cord.

HOW TO USE THE INFORMATION MODE

To access the information mode, hold down the STOP button while inserting the key into the console.

The DISTANCE/LAPS display will show the total number of miles that the walking belt has moved.

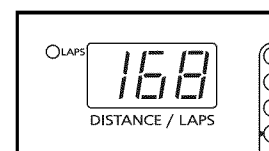

The TIME/INCLINE display will show the total number of hours that the treadmill has been used.

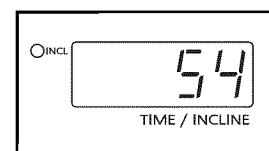

An "E," for english miles, or an "M," for metric kilometers, will appear in the CALORIES/PULSE display. If you want to change the unit of measurement, press the SPEED Δ button.

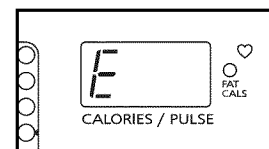

To exit the information mode, remove the key from the console.

TROUBLE-SHOOTING

Most treadmill problems can be solved by following the steps below. Find the symptom that applies, and follow the steps listed. If further assistance is needed, please call our Customer Service Department toll-free at 1-800-999-3756, Monday through Friday, 6 a.m. until 6 p.m. Mountain Time (excluding holidays).

PROBLEM: The power does not turn on

SOLUTION: a. Make sure that the power cord is plugged into a surge suppressor, and that the surge suppressor is plugged into a properly grounded outlet (see page 7). Use only a single-outlet surge suppressor that is UL 1449 listed as a transient voltage surge suppressor (TVSS). The surge suppressor must have a UL suppressed voltage rating of 400 volts or less and a minimum surge dissipation of 450 joules. The surge suppressor must be electrically rated for 120 volts AC and 15 amps. Important: The treadmill is not compatible with GFCI-equipped outlets.

b. After the power cord has been plugged in, make sure that the key is fully inserted into the console.

c. Check the circuit breaker located on the treadmill near the power cord. If the switch protrudes as shown, the circuit breaker has tripped. To reset the circuit breaker, wait for five minutes and then press the switch back in.

d. Check the on/off switch located on the treadmill near the power cord. The switch must be in the on position.

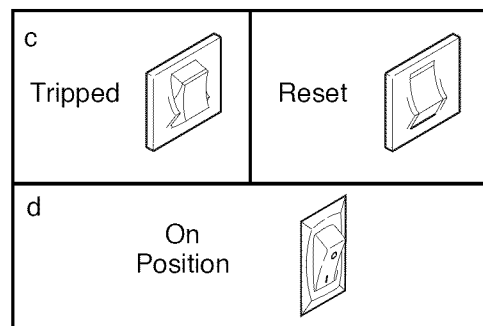

PROBLEM: The power turns off during use

SOLUTION: a. Check the circuit breaker located on the treadmill near the power cord. If the circuit breaker has tripped, wait for five minutes and then press the switch back in.

b. Make sure that the power cord is plugged in.

c. Remove the key from the console. Reinsert the key fully into the console.

d. Make sure that the on/off switch is in the on position.

e. If the treadmill still will not run, please call our Customer Service Department, toll-free.

PROBLEM: The walking belt slows when walked on

SOLUTION: a. Use only an appropriate surge suppressor (see a. near the top of this page).

b. If the walking belt is overtightened, treadmill performance may decrease and the walking belt may become damaged. Remove the key and **UNPLUG THE POWER CORD**. Using the allen wrench, turn both rear roller adjustment bolts counterclockwise 1/4 of a turn. When the walking belt is properly tightened, you should be able to lift each side of the walking belt 2 to 3 inches off the walking platform. Be careful to keep the walking belt centered. Plug in the power cord, insert the key, and run the treadmill for a few minutes. Repeat until the walking belt is properly tightened.

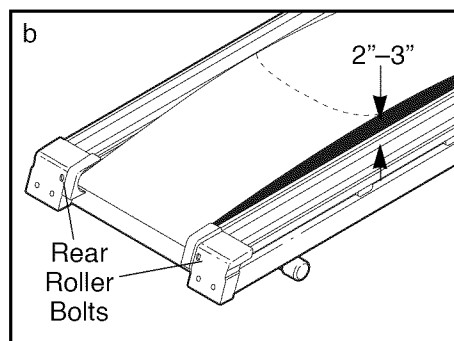

c. If the walking belt still slows when walked on, please call our Customer Service Department, toll-free.

PROBLEM: The walking belt is off-center

SOLUTION: a. **If the walking belt has shifted to the left**, first remove the key and **UNPLUG THE POWER CORD**. Using the allen wrench, turn the left rear roller adjustment bolt clockwise, and the right bolt counterclockwise, 1/4 of a turn each. Be careful not to overtighten the walking belt. Plug in the power cord, insert the key and run the treadmill for a few minutes. Repeat until the walking belt is centered.

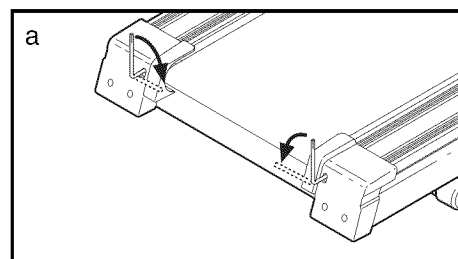

b. **If the walking belt has shifted to the right**, first remove the key and **UNPLUG THE POWER CORD**. Using the allen wrench, turn the left rear roller adjustment bolt counterclockwise, and the right bolt clockwise, 1/4 of a turn each. Be careful not to overtighten the walking belt. Plug in the power cord, insert the key and run the treadmill for a few minutes. Repeat until the walking belt is centered.

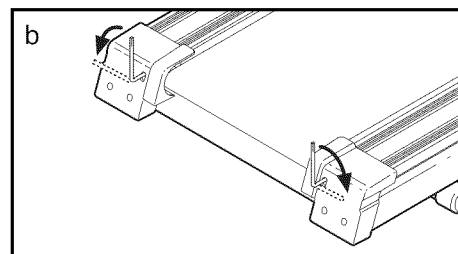

c. **If the walking belt slips when walked on**, first remove the key and **UNPLUG THE POWER CORD**. Using the allen wrench, turn both rear roller adjustment bolts clockwise 1/4 of a turn. When the walking belt is correctly tightened, you should be able to lift each side of the walking belt 2 to 3 inches off the walking platform. Be careful to keep the walking belt centered. Plug in the power cord, insert the key and carefully walk on the treadmill for a few minutes. Repeat until the walking belt is properly tightened.

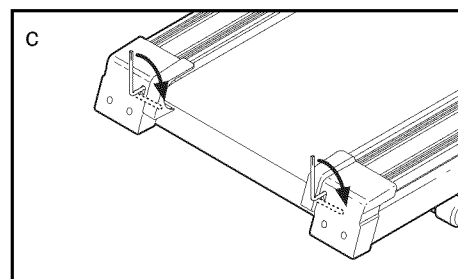

PROBLEM: The SPEED/PACE display on the console does not function properly

SOLUTION: a. Remove the key from the console and **unplug the power cord**. Remove the screws from the hood and carefully remove the hood. Locate the Reed Switch (17) and the Magnet (69) on the left side of the Pulley (72). Turn the Pulley until the Magnet is aligned with the Reed Switch. **Make sure that the gap between the Magnet and the Reed Switch is about 1/8"**. If necessary, loosen the Reed Switch Screw (19) and move the Reed Switch slightly. Retighten the Screw. Re-attach the hood and run the treadmill for a few minutes to check for a correct speed reading.

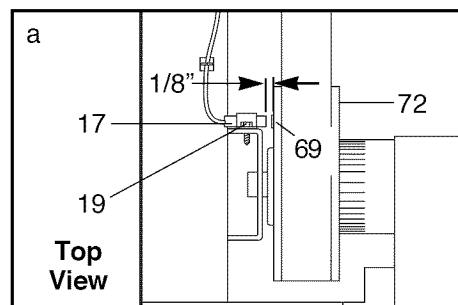

PROBLEM: The incline of the treadmill does not change correctly

SOLUTION: a. With the key in the console, press one of the incline buttons. **While the incline is changing, remove the key**. After a few seconds, re-insert the key. The treadmill will automatically rise to the maximum incline level and then return to the minimum level. This will recalibrate the incline system.

PROBLEM: The heart rate monitor does not function properly

SOLUTION: a. If the heart rate monitor does not function properly, see HEART RATE MONITOR TROUBLE-SHOOTING on page 6.

b. If the heart rate monitor still does not function properly, the battery should be changed. To replace the battery, locate the battery cover on the back of the sensor unit. Insert a coin into the slot in the cover and turn the cover counterclockwise to the “open” position. Remove the cover.

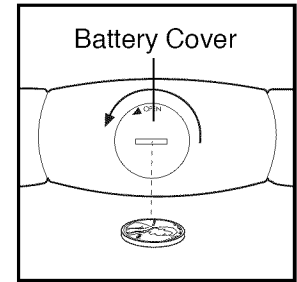

Remove the old battery from the sensor unit. Insert a new **CR 2032 battery**, making sure that the writing is on top. In addition, make sure that the rubber gasket is in place in the sensor unit. Replace the battery cover and turn it to the closed position.

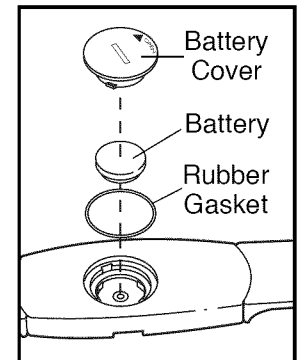

CONDITIONING GUIDELINES

⚠ WARNING: Before beginning any exercise program, consult your physician. This is especially important for individuals over the age of 35 or individuals with pre-existing health problems.

The heart rate monitor is not a medical device. Various factors may affect the accuracy of heart rate readings. The heart rate monitor is intended only as an exercise aid in determining heart rate trends in general.

The following guidelines will help you to plan your exercise program. For more detailed information about exercise, obtain a book or consult your physician.

EXERCISE INTENSITY

Whether your goal is to burn fat or strengthen your cardiovascular system, the key to achieving the desired results is to exercise with the proper intensity. The proper intensity level can be found by using your heart rate as a guide. For effective exercise, your heart rate should be maintained at a level between 65% and 85% of your maximum heart rate as you exercise. This is known as your training zone. You can find your training zone in the table below. Training zones are listed according to age and physical condition.

Age	Training Zone (Beats/Min.)	
	Unconditioned	Conditioned
20	138-167	133-162
25	136-166	132-160
30	135-164	130-158
35	134-162	129-156
40	132-161	127-155
45	131-159	125-153
50	129-156	124-150
55	127-155	122-149
60	126-153	121-147
65	125-151	119-145
70	123-150	118-144
75	122-147	117-142
80	120-146	115-140

Fat Burning

To burn fat, you must exercise at a low intensity level for a sustained period of time. During the first few minutes of exercise, your body uses easily accessible carbohydrate calories for energy. Only after the first few minutes of exercise does your body begin to use stored fat calories for energy. If your goal is to burn fat, adjust the intensity of your exercise until your heart rate is near the low end of your training zone as you exercise.

Aerobic Exercise

If your goal is to strengthen your cardiovascular system, your exercise must be “aerobic.” Aerobic exercise is activity that requires large amounts of oxygen for prolonged periods of time. This increases the demand on the heart to pump blood to the muscles, and on the lungs to oxygenate the blood. For aerobic exercise, adjust the intensity of your exercise until your heart rate is near the middle of your training zone.

WORKOUT GUIDELINES

Each workout should include the following three important parts:

A Warm-up—Warming up prepares the body for exercise by increasing circulation, delivering more oxygen to the muscles, and raising the body temperature. Begin each workout with 5 to 10 minutes of stretching and light exercise to warm up.

Training Zone Exercise—After warming up, increase the intensity of your exercise until your heart rate is in your training zone for 20 to 60 minutes. (During the first few weeks of your exercise program, do not keep your heart rate in your training zone for longer than 20 minutes.) Breathe regularly and deeply as you exercise—never hold your breath.

A cool-down—Finish each workout with 5 to 10 minutes of stretching to cool down. This will increase the flexibility of your muscles and will help to prevent post-exercise problems.

EXERCISE FREQUENCY

To maintain or improve your condition, complete three workouts each week, with at least one day of rest between workouts. After a few months, you may complete up to five workouts each week if desired.

The key to success is to make exercise a regular and enjoyable part of your everyday life.

PART LIST—Model No. IMTL07800

R0900A

Note: To identify the parts listed below, refer to the EXPLODED DRAWING attached in the center of this manual.

Key No.	Qty.	Description	Key No.	Qty.	Description
1	4	Console Base Screw	53	4	Upright Pivot Washer
2	12	Belly Pan Screw	54	2	Wheel Nut
3	2	Handrail Cap	55	2	Foot Endcap
4	2	Nylon Washer	56	2	Belt Guide
5	5	Incline Bolt/Motor Bolt	57	2	Incline Wheel
6	2	Push Nut	58	1	Motor Belt
7	6	Upright Bolt	59	1	Motor
8	2	Round Upright Cap	60	1	Pulley/Flywheel/Fan
9	2	Cage Nut	61	1	Motor/Pulley/Flywheel/Fan
10	2	Wheel Bolt	62	1	Wire Harness
11	2	Upright Spacer	63	2	Wire Harness Grommet
12	5	Nut	64	1	Key/Clip
13	1	Incline Motor Bolt	65	2	Foam Grip
14	4	Endcap Bolt	66	1	Chest Pulse Sensor
15	2	Roller Adjustment Bolt	67	2	Optic Switch Bolt
16	2	Rear Platform Screw	68	1	Console
17	1	Reed Switch	69	1	Magnet
18	1	Reed Switch Clip	70	6	Isolator
19	1	Reed Switch Screw	71	1	Incline Motor
20	5	Hood Anchor Screw	72	1	Front Roller
21	5	Hood Anchor	73	1	Rear Roller
22	3	Tie Holder	74	1	Left Rail
23	1	Motor Tension Washer	75	1	Incline Leg
24	1	Motor Tension Star Washer	76	1	Chest Pulse Strap
25	5	Upright Nut/Motor Tension Nut	77	1	Rear Roller Ground Wire
26	1	Motor Pivot Bolt	78	4	Plastic Standoff
27	19	Screw	79	1	Front Roller Adjustment Bolt
28	1	Small Nut	80	1	Upright
29	5	Hood Screw	81	1	Optic Switch
30	6	Platform Screw	82	2	Incline Spacer
31	4	8" Wire Tie	83	1	Walking Belt
32	1	Rear Endcap (Left)	84	1	Walking Platform
33	2	Small Star Washer	85	1	Hood
34	1	Allen Wrench	86	1	Belly Pan
35	1	Flywheel Guard	87	1	Frame
36	1	Power Supply with Clips	88	1	Right Rail
37	2	1" Plug	89	1	Rear Endcap (Right)
38	1	Switch Bracket	90	1	Staple Cover (Left)
39	1	Circuit Breaker	91	1	Staple Cover (Right)
40	1	On/Off Switch	92	1	40" Pulse Wire
41	1	Controller	#	1	14" White Wire, 2 Female
42	1	Power Cord	#	1	8" White Wire, 2 Female
43	1	Grommet	#	1	4" White Wire, Male/Female
44	1	Electronics Bracket	#	1	4" Black Wire, 2 Female
45	1	Incline Disk	#	1	8" Blue Wire, 2 Female
46	1	Optic Sensor Wire	#	1	4" Blue Wire, 2 Female
47	3	Releasable Wire Tie	#	1	8" Green Wire, F/Ring
48	1	Front Roller Ground Wire	#	1	User's Manual
49	1	Motor-Controller Wire			
50	2	Frame Endcaps			
51	2	Adjustment Washer			
52	1	Pulse Receiver			

* Includes all parts shown in the box

These parts are not illustrated

EXPLODED DRAWING—Model No. IMTL07800

R0900A

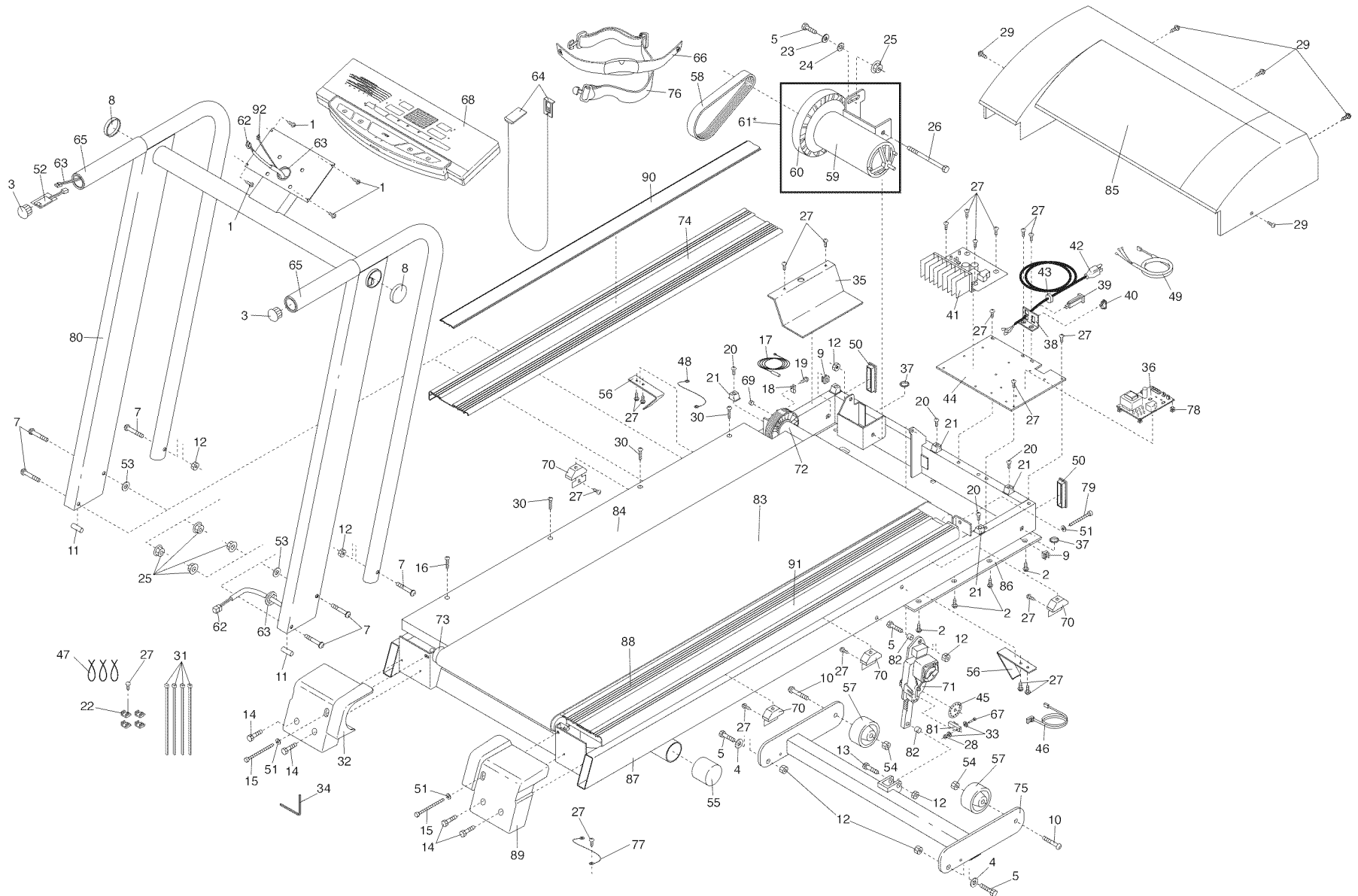

ORDERING REPLACEMENT PARTS

To order replacement parts, call our Customer Service Department toll-free at 1-800-999-3756, Monday through Friday, 6 a.m. until 6 p.m. Mountain Time (excluding holidays). When ordering parts, please be prepared to give the following information:

When requesting help or service, or ordering parts, please be prepared to provide the following information:

- The MODEL NUMBER of the product (IMTL07800)
- The NAME of the product (IMAGE® SE 7.8 treadmill)
- The SERIAL NUMBER of the product (see the front cover of this manual)
- The KEY NUMBER AND DESCRIPTION OF THE PART (see the PART LIST and the EXPLODED DRAWING in the center of this manual)

If possible, place the treadmill near your telephone for easy reference when calling.

IMAGE is a registered trademark of ICON Health & Fitness, Inc.

LIMITED WARRANTY

ICON Health & Fitness, Inc. (ICON), warrants this product to be free from defects in workmanship and material, under normal use and service conditions, for a period of ninety (90) days from the date of purchase. This warranty extends only to the original purchaser. ICON's obligation under this warranty is limited to replacing or repairing, at ICON's option, the product at one of its authorized service centers. All products for which warranty claim is made must be received by ICON at one of its authorized service centers with all freight and other transportation charges prepaid, accompanied by sufficient proof of purchase. All returns must be pre-authorized by ICON. This warranty does not extend to any product or damage to a product caused by or attributable to freight damage, abuse, misuse, improper or abnormal usage or repairs not provided by an ICON authorized service center, to products used for commercial or rental purposes, or to products used as store display models. No other warranty beyond that specifically set forth above is authorized by ICON.

ICON is not responsible or liable for indirect, special or consequential damages arising out of or in connection with the use or performance of the product or damages with respect to any economic loss, loss of property, loss of revenues or profits, loss of enjoyment or use, costs of removal, installation or other consequential damages of whatsoever nature. Some states do not allow the exclusion or limitation of incidental or consequential damages. Accordingly, the above limitation may not apply to you.

The warranty extended hereunder is in lieu of any and all other warranties and any implied warranties of merchantability or fitness for a particular purpose is limited in its scope and duration to the terms set forth herein. Some states do not allow limitations on how long an implied warranty lasts. Accordingly, the above limitation may not apply to you.

This warranty gives you specific legal rights. You may also have other rights which vary from state to state.

ICON HEALTH & FITNESS, INC., 1500 S. 1000 W., LOGAN, UT 84321-9813