

SEARS®

Model No. 831.157032
Serial No. _____

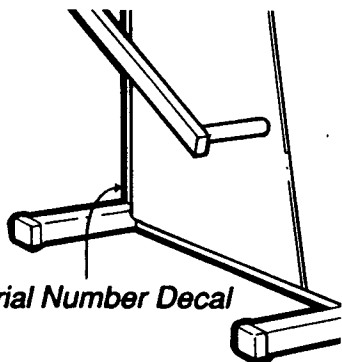

QUESTIONS?

As a manufacturer, we are committed to providing you complete customer satisfaction. If you have questions, or find there are missing or damaged parts, we will guarantee you complete satisfaction through direct assistance from our factory. TO AVOID UNNECESSARY DELAYS, PLEASE CALL DIRECT TO OUR TOLL-FREE CUSTOMER HOT LINE. The trained technicians on our Customer Hot Line will provide immediate assistance, free of charge to you.

CUSTOMER HOT LINE:
1-800-999-3756
Mon.-Fri., 6 a.m.-6 p.m. MST.

CAUTION:

Read all safety precautions and instructions in this manual carefully before using this equipment. Save this manual for future reference.

PRO-FORM®

EDGE 4001™

**MULTI-DIMENSIONAL TRAINING SYSTEM •
250 LBS ELECTRONIC RESISTANCE CONTROL**

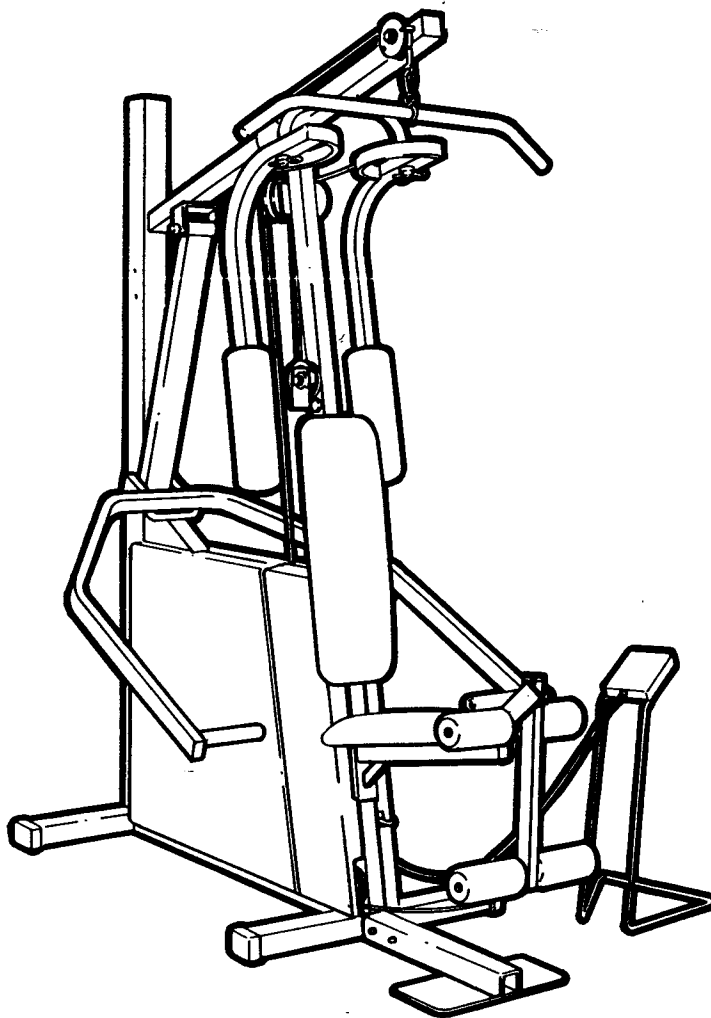

OWNER'S MANUAL

SOLD BY SEARS, ROEBUCK AND CO., CHICAGO, IL 60684

TABLE OF CONTENTS

Important Safety Precautions	2
Before You Begin	3
Assembly	4
Operation and Adjustment	5
Maintenance and Trouble-Shooting	7
Exercise Guidelines	8
Part List	10
Exploded Drawing	11
Ordering Replacement Parts	Back Cover
Warranty	Back Cover

IMPORTANT SAFETY PRECAUTIONS

WARNING: To reduce the risk of serious injury, read the following important safety precautions before using the system.

1. Read all instructions in this owner's manual before using the system. Use the system only as described in this owner's manual.
2. Inspect and tighten all parts each time the system is used. Replace any worn parts.
3. Always wear shoes for foot protection. Keep your hands away from moving parts other than the designated handles. Keep small children away from the system at all times.
4. To prevent damage to the system, do not put any pressure on the system while changing the weight. Never use more than one cable at a time.
5. Always remove the lat bar and chain when not in use (see OPERATION AND ADJUSTMENT in this manual).
6. Never release the press arm, butterfly arms, lat bar or leg lever while they are under tension.

WARNING: Before beginning this or any exercise program, consult with your physician. This is especially important for individuals over the age of 35 or persons with pre-existing health problems. Read all instructions before using. Sears assumes no responsibility for personal injury or property damage sustained by or through the use of this product.

BEFORE YOU BEGIN

Congratulations for selecting the Pro Form EDGE 4001 Multi-Dimensional Training System. The unique EDGE 4001 is a total body conditioning system, offering both weight training and aerobic exercises. Moving from station to station on the EDGE 4001 is quick and easy, and the digital hand control allows you to change weight with the touch of a button. Whether you want to build dramatic muscle size and strength, shape and tone your body, increase your endurance and flexibility or develop your heart and lungs, the EDGE 4001 will help you achieve your goals in the privacy and comfort of your home.

This manual is provided to help you understand the easy assembly, adjustment and operation of the system. **For your safety and benefit, read this manual carefully before using the system.** If you have additional questions, please call our Customer Service Department toll-free at **1-800-999-3756**, Monday through Friday, 6 a.m. until 6 p.m. Mountain Time (excluding holidays). To help us assist you, please note your product model number and serial number before calling. The model number is listed on the front cover of this manual. The serial number is recorded on a decal attached to the system (see the front cover for the location of the decal).

Before reading further, please review the drawing below and familiarize yourself with the parts labeled.

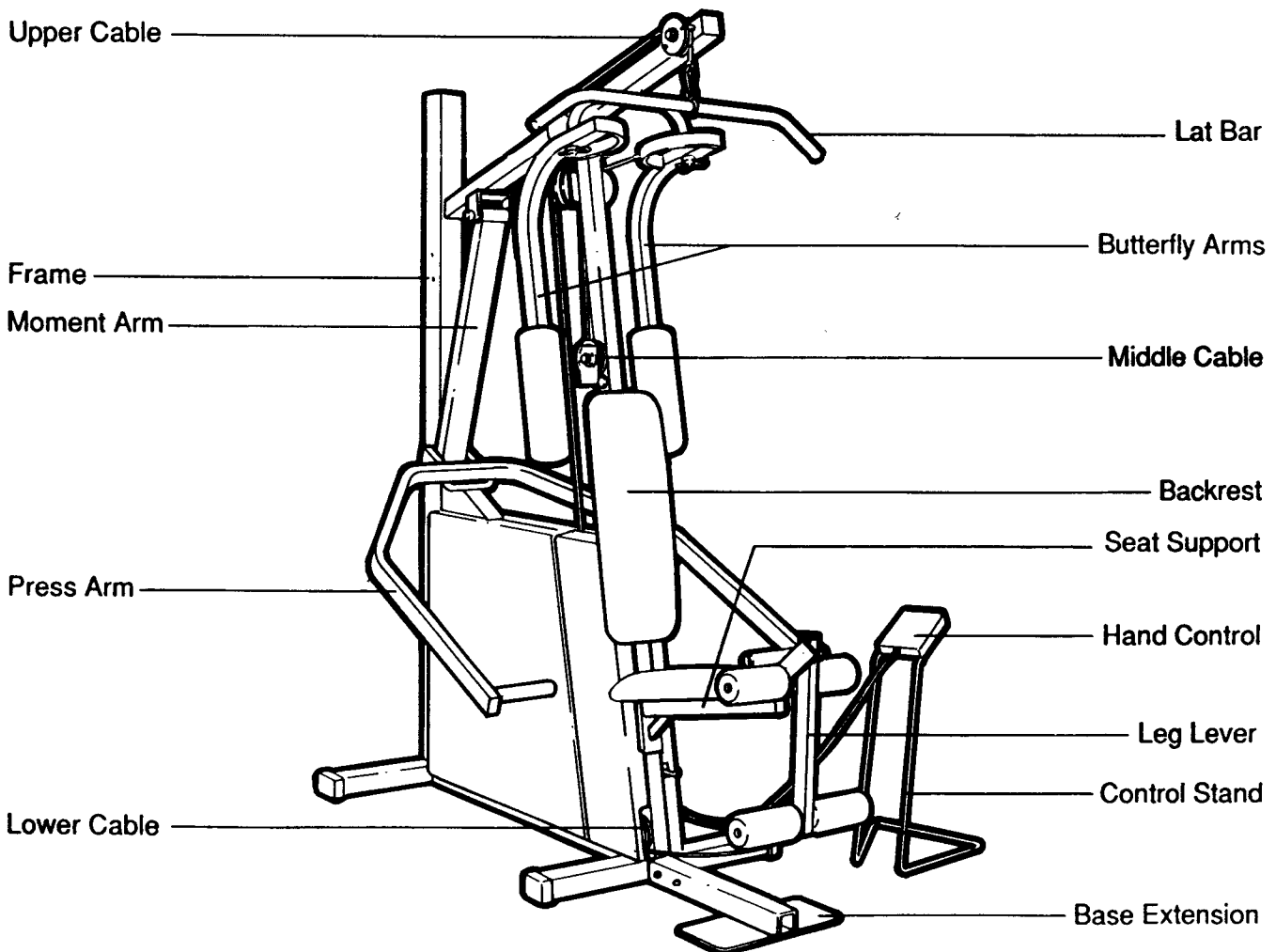

ASSEMBLY

Two persons are recommended in order to assemble the system. Set all parts in a cleared area. **Make sure that all parts are included before disposing of the packing materials.** Read each step carefully before beginning. Assembly can be completed using a standard screwdriver and two adjustable wrenches (not included).

1. Press a Front Stabilizer Endcap (70) onto each side of the front stabilizer of the Frame (1). Slide the Base Extension (47) onto the Frame, and align the holes. Attach the Base Extension with the two Extension Bolts (48) and Nylock Nuts (3).

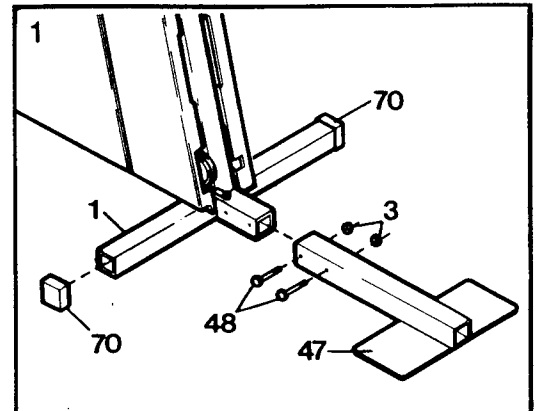

2. Rotate the Leg Lever (42) to the position shown. Insert the bracket on the Seat Support (40) into the slots in the Side Shields (55, 56). Slide the bracket onto one of the three sets of pins welded to the Frame (1). Use the pins which set the Seat Support in the most comfortable exercising position. **WARNING: Be sure the pins are inside of the slots in the bracket.**

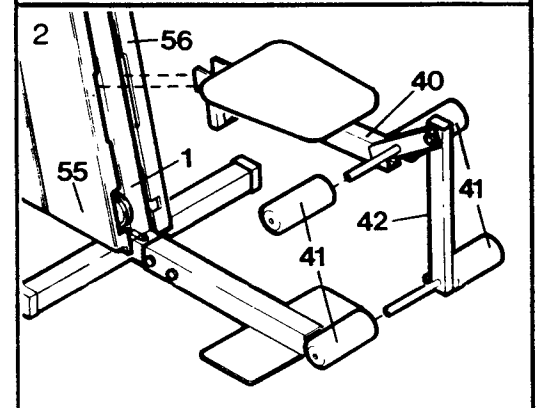

Slide the four Leg Lever Pads (41) onto the posts on the Seat Support (40) and Leg Lever (42).

3. Attach the Hand Control (51) to the Control Stand (50) with the two Control Stand Screws (69). Plug one end of the Control Cord (49) into the Hand Control. Plug the other end of the Control Cord into the Control Cord Socket (67) at the front of the system.

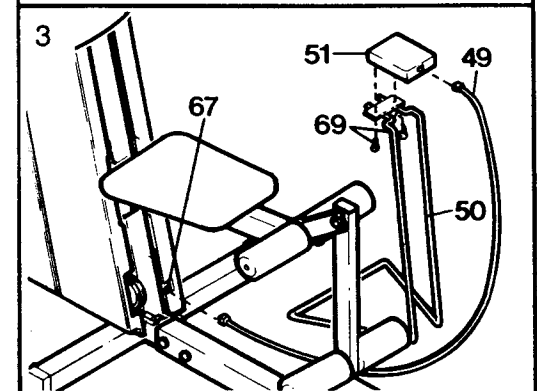

4. Press a Rear Stabilizer Endcap (2) onto each end of the rear stabilizer of the Frame (1). Plug the Power Cord (68) into the socket at the back of the system.

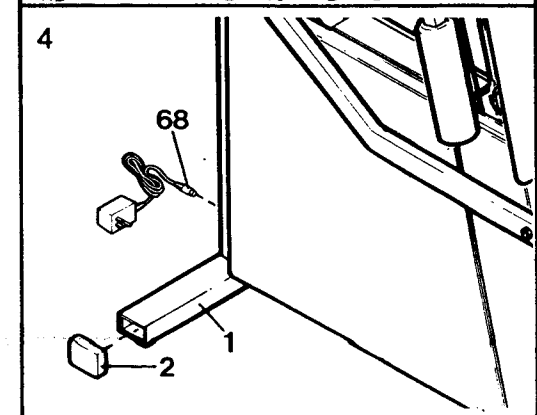

5. Liberally grease the Press Arm Axle (10). Align the holes in the Press Arm (12) with the holes in the Moment Arm (13). Insert the Press Arm Axle through the Press Arm and Moment Arm.

Using a standard screwdriver, turn the Press Arm Axle (10) until the hole in the Axle is aligned with the hole located at the front of the Moment Arm (13). Tighten the Press Arm Axle Bolt (11), Lockwasher (78) and Washer (66) into the Moment Arm and Press Arm Axle.

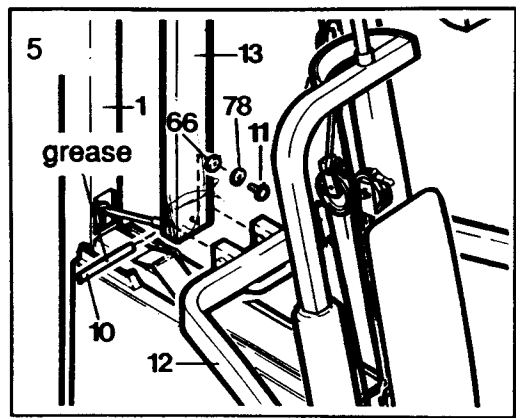

OPERATION AND ADJUSTMENT

Plug the transformer on the power cord into a 120-volt outlet. Keep the power cord away from walkways and heated surfaces. Turn on the power when using the system, or the system could be damaged. When you are finished using the system, always unplug the transformer.

DIAGRAM OF THE HAND CONTROL

1. Low/High Range Indicator- Shows when the system is set at minimum or maximum weight.
2. Weight Display- Displays the current weight setting.
3. On/Off Button- Turns the power on and off.
4. Weight Increase Button- Increases the weight.
5. Weight Decrease Button- Decreases the weight.

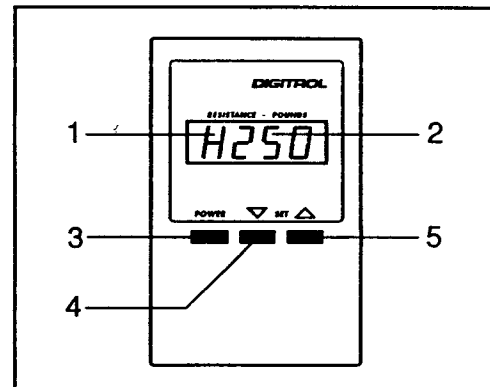

TURNING ON THE POWER AND RESETTING THE SYSTEM

Press the on/off button. **IMPORTANT: Each time the power is turned on, the system must be reset before the weight can be changed.** The weight display will read "E---." To reset the system, press the weight increase or decrease buttons until the display reads "H250" (maximum weight) or "L30" (minimum weight).

CHANGING THE WEIGHT SETTING OF THE SYSTEM

The weight can be changed from a minimum of 30 lbs, to a maximum of 250 lbs, in increments of 1 pound. To increase the weight, press the weight increase button. To decrease the weight, press the weight decrease button. The buttons can be held down to change the weight quickly. **IMPORTANT: To prevent damage to the system, do not put any pressure on the system while changing the weight. Do not push on the press arm or leg lever. If the lat bar is attached to the system, it may be helpful to support the weight of the lat bar with one hand. The system motor will emit a sound to alert you while the weight is being changed.**

ATTACHING AND REMOVING THE SEAT SUPPORT

The seat support should be attached to the system as described in the assembly instructions. For certain exercises, the seat support must be removed. First, remove the lower cable from the leg lever. Then, lift the seat support until the bracket on the seat support is free of the pins on the frame.

ATTACHING THE LEG LEVER TO THE WEIGHT SYSTEM

To attach the leg lever to the weight system, attach the cable extension between the leg lever and the lower cable with two connector links. (See fig. 1)

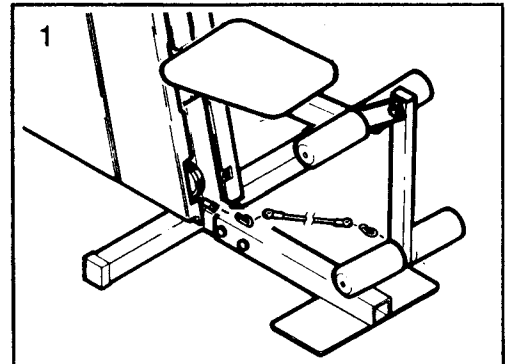

ATTACHING THE LAT BAR TO THE WEIGHT SYSTEM

To attach the lat bar directly to the lower cable, first disconnect the cable extension from the leg lift. Remove the seat support from the frame as described above. Attach the lat bar to the cable extension using a connector link. (See fig. 2)

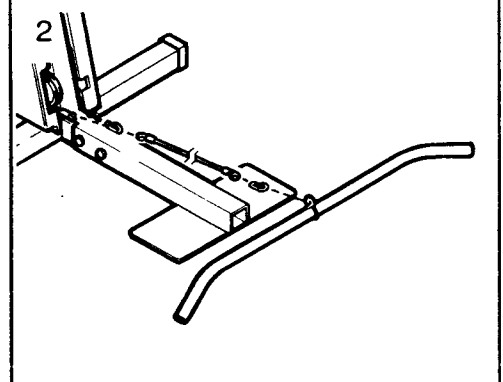

To use the lat bar with the middle or upper cable, the chain must be attached between the lat bar and the cable using the two connector links. The chain can be shortened by attaching the connector links closer together along the chain. **IMPORTANT:** The proper length of chain between the lat bar and the upper cable should be determined by the exercise to be performed. Adjust the length of chain until the lat bar is in a comfortable starting position. (See fig. 3, 4)

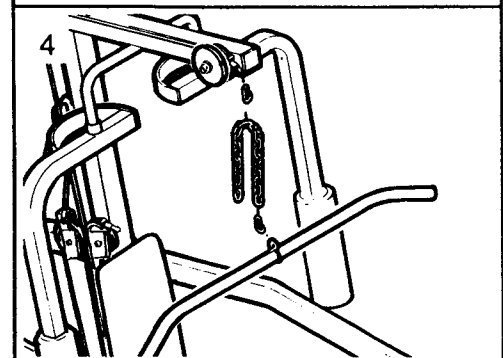
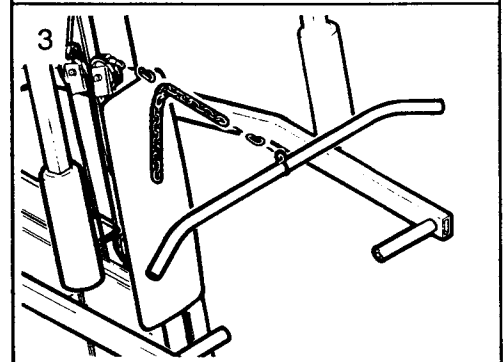

ATTACHING THE ROWER BAR TO THE WEIGHT SYSTEM

The rower bar should be attached to the weight system in the same manner as the lat bar. See ATTACHING THE LAT BAR TO THE WEIGHT SYSTEM above. (See fig. 2-4)

ATTACHING THE ABDOMINAL STRAP TO THE WEIGHT SYSTEM

The abdominal strap is designed to be used with the middle cable. Remove any attachments from the middle cable. Attach the abdominal strap to the middle cable with a connector link.

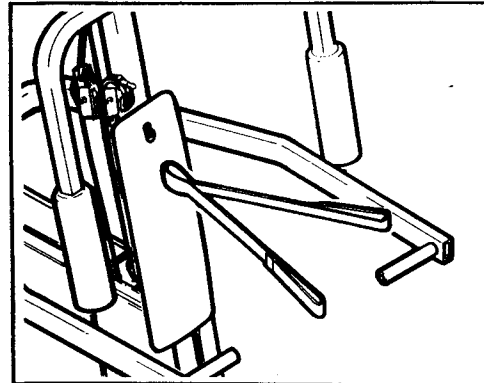

ATTACHING THE ANKLE STRAP

The ankle strap is designed to be used with the lower pulley. Remove any attachments from the lower pulley. The cable extension can be attached between the ankle strap and the lower cable with two connector links. The ankle strap can also be attached directly to the lower cable with a single connector link.

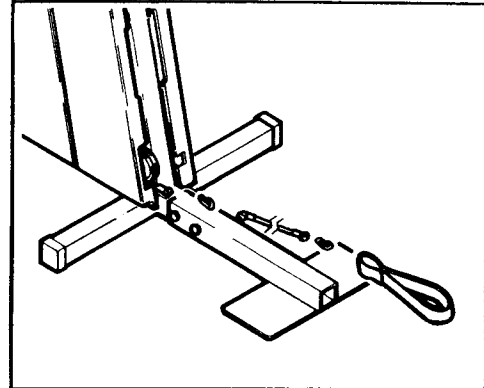

MAINTENANCE AND TROUBLE-SHOOTING

Inspect and tighten all parts each time the system is used. Replace any worn parts immediately. The outside of the system can be cleaned using a damp cloth and mild, non-abrasive detergent. Do not use solvents.

ADJUSTING THE WEIGHT SYSTEM

If there is slack in the weight system before the weight engages, the cables may need to be adjusted. To adjust the cables, a phillips screwdriver and two adjustable wrenches (not included) are required. Remove the screws from the right side shield, and carefully move the side shield out of the way. (See fig. 1.) Locate the two pulleys connected by two I-brackets. The I-brackets have a selection of ten holes which tighten the cables in small increments. Remove the upper pulley from the two I-brackets using two adjustable wrenches. Move the pulley to the next lower hole in the I-brackets. (Figure 2 shows the order the top pulley should move down to tighten the weight system.) Reattach the upper pulley to the I-brackets in the new position. Test the weight system before reattaching the side shield. If the motor stalls or hesitates, the cable is too tight. Move the pulley back to the previous hole. If there is still slack in the weight system, move the cable to the next lower hole as described above. If the cable is attached to the lowest hole in the I-brackets and there is still slack in the weight system, the cables should be replaced (refer to the back cover). Re-attach the side shield.

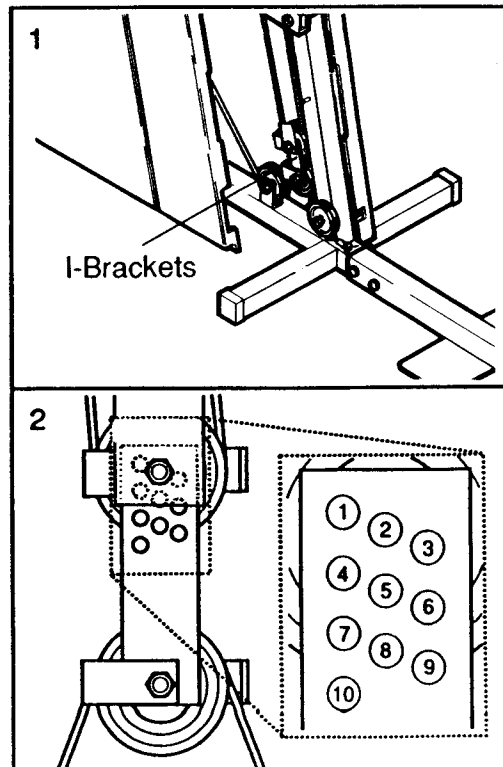

LUBRICATING THE BUTTERFLY ARMS AND PRESS ARM

The butterfly arms and press arm should be lubricated every six months with a petroleum-based grease. To lubricate the butterfly arms, remove the hairpin cotter pins and slide the butterfly arms off of the frame. Grease the bushings in the butterfly arms. Re-attach the butterfly arms with the hairpin cotter pins.

To lubricate the press arm, an adjustable wrench is required. Remove the bolt, lockwasher and washer from the lower end of the moment arm. While supporting the press arm, remove the press arm axle. Liberally grease the axle. Re-attach the press arm to the moment arm as described in assembly step 5. (See page 5)

EXERCISE GUIDELINES

WARNING: Before beginning any exercise program, consult with your physician. This is especially important for individuals over the age of 35 or persons with pre-existing health problems.

WEIGHT TRAINING

This system offers a full selection of weight training exercises. Follow the guidelines below to outline an exercise program to achieve the specific results you want. Your exercise program should include three, 30-minute workouts each week, with at least one day of rest between workouts. Each workout should include 6-10 different exercises. Select exercises for all major muscle groups, with emphasis on the areas you want to develop most. To give variety and balance to your workouts, vary the exercises from day to day.

To increase the size and strength of muscles, the muscles must be worked to capacity. Each exercise should be tailored to the proper intensity level by changing the amount of weight used, or the number of "repetitions" and "sets" performed. (A "repetition" is a single exercise movement, such as one sit-up. A "set" is a number of repetitions performed continuously.)

Be careful not to overexert yourself. Begin and end every workout with 5-10 minutes of stretching or light calisthenics. Rest for 30 seconds after each set, and 1 minute after each exercise. Concentrate on learning the exercises correctly. Exhale as you exert yourself, and inhale as you relax. Never hold your breath. Schedule your workouts for the time of day when your energy level is highest.

Wear clothing that is loose-fitting and allows unrestricted movement. Always wear shoes for foot protection. For added motivation, keep a record of your workouts. List the dates, exercises performed, weight used, and number of repetitions and sets completed. Record key body measurements every 4-6 weeks. For successful results, proper nutrition and adequate rest are also essential. For more information about exercise and diet, consult with your physician.

CARDIOVASCULAR CONDITIONING

The leg lever, lat bar and press bar can be used for an excellent cardiovascular workout. Set the weight at the lowest setting and do as many repetitions and sets as desired. For an effective cardiovascular workout, your heart rate should be kept at a level between 70% and 85% of your maximum heart rate. This is your "training zone." You can find your training zone by consulting the table below. Training zones are listed for both unconditioned and conditioned persons, ages 20 to 85 years.

AGE	UNCONDITIONED TRAINING ZONE (BEATS/MIN)	CONDITIONED TRAINING ZONE (BEATS/MIN)	AGE	UNCONDITIONED TRAINING ZONE (BEATS/MIN)	CONDITIONED TRAINING ZONE (BEATS/MIN)
20	138-167	133-162	55	127-155	122-149
25	136-166	132-160	60	126-153	121-147
30	135-164	130-158	65	125-151	119-145
35	134-162	129-156	70	123-150	118-144
40	132-161	127-155	75	122-147	117-142
45	131-159	125-153	80	120-146	115-140
50	129-156	124-150	85	118-144	114-139

During the first few weeks of exercise, keep your heart rate near the low end of your training zone. To measure your heart rate, stop exercising and place two fingers over your wrist as shown.

Carefully take a six-second heartbeat count. Multiply the result by 10 to find your heart rate. For example, if your six-second heartbeat count is 14, your heart rate is 140 beats per minute. (A six-second count is used because your heart rate will drop rapidly after you stop exercising.) Compare your heart rate to your training zone. If your heart rate is below your training zone, increase the intensity of your exercise. If your heart rate is too high, decrease the intensity.

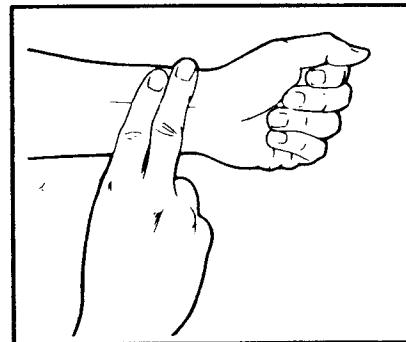

Begin and end every workout with 5-10 minutes of stretching or light calisthenics. Exercise with your heart rate in your training zone for about 30 minutes. It makes no difference whether this is done in one continuous 30-minute period, or in a few shorter periods, such as three 10-minute periods. To maintain or improve your condition, exercise three times per week, with at least one day of rest between workouts. After a few months, the number of workouts can be increased to 4-5 per week.

PART LIST- Model No. 831.157032

Rev. 11/91

Key No.	Part No.	Qty.	Description	Key No.	Part No.	Qty.	Description
1	NSP	1	Frame	42	107379	1	Leg Lever
2	105317	2	Rear Stabilizer Endcap	43	104794	1	Leg Lever Endcap
3	012108	17	Nylock Nut	44	107653	1	Leg Lever Pin
4	104049	2	3/8" x 3.50" Bolt	45	100150	1	Leg Lever Axle Cap
5	013564	1	3/8" x 1.75" Bolt	46	013456	2	Seat Bolt
6	013580	7	3/8" x 2.00" Bolt	47	105325	1	Base Extension
7	013341	3	1/4" x 2.5" Bolt	48	105329	2	Extension Bolt
8	101262	12	Pulley	49	106786	1	Control Cord
9	106659	2	Press Arm Bushing	50	107563	1	Control Stand
10	105356	1	Press Arm Axle	51	105922	1	Hand Control
11	013186	1	Press Arm Axle Bolt	52	105311	1	Lat Bar
12	107814	1	Press Arm	53	105315	1	Chain
13	107377	1	Moment Arm	54	103087	3	Connector Link
14	100048	2	Moment Arm Bushing	55	107382	1	Right Side Shield
15	103735	2	Moment Arm Axle Cap	56	107383	1	Left Side Shield
16	105300	1	Pulley U-Bracket	57	013574	1	3/8" x 2.25" Bolt
17	107640	2	Pulley Plate	58	105309	1	PVC Spacer
18	106641	1	Upper Cable	59	106643	1	Abdominal Strap
19	106640	1	Lower Cable	60	106642	1	Top Cover
20	105295	2	Butterfly Cable	61	013303	2	5/16" x 1.00" Bolt
21	013519	1	3/8" x 3.00" Bolt	62	105172	1	Frame Endcap
22	107807	1	Moment Arm Axle	63	014156	5	Guard Washer
23	107692	1	Weight Mechanism	64	103050	2	Butterfly Endcap
24	105316	12	Screw	65	106719	4	L-Bracket
25	107381	1	Wire Harness	66	014164	1	Press Arm Washer
26	107367	2	Gas Shock	67	106982	1	Control Cord Socket
27	105142	2	Ball Joint	68	101067	1	Power Cord
28	014041	2	Washer	69	103860	2	Control Stand Screw
29	105234	4	Gas Shock Clip	70	105723	2	Front Stabilizer Endcap
30	105332	1	Right Butterfly Arm	71	107479	1	Cable Extension
31	105340	1	Left Butterfly Arm	72	014063	2	Backrest Washer
32	105342	2	Butterfly Pad	73	107281	1	Rower Bar
33	105497	4	Butterfly Bushing	74	107048	1	Ankle Strap
34	105866	2	Hairpin Cotter Pin	75	106465	3	3/8" x 3.75" Bolt
35	012082	4	Small Nut	76	107483	4	Pulley Guard
36	106668	2	Small Pulley Spacer	77	107484	4	L-Pulley Guard
37	106480	1	Small Pulley	78	014062	1	Lock Washer
38	105318	1	Backrest	#	107808	1	Owner's Manual
39	105376	1	Seat	#	107576	1	Exercise Manual
40	107378	1	Seat Support	#	104838	1	Grease
41	103805	4	Leg Lever Pad				

Note: "#" indicates a non-illustrated part. Specifications are subject to change without notice. See the back cover about information about ordering replacement parts.

EXPLODED DRAWING- Model No. 831.157032

Rev. 11/91

Specifications are subject to change without notice.

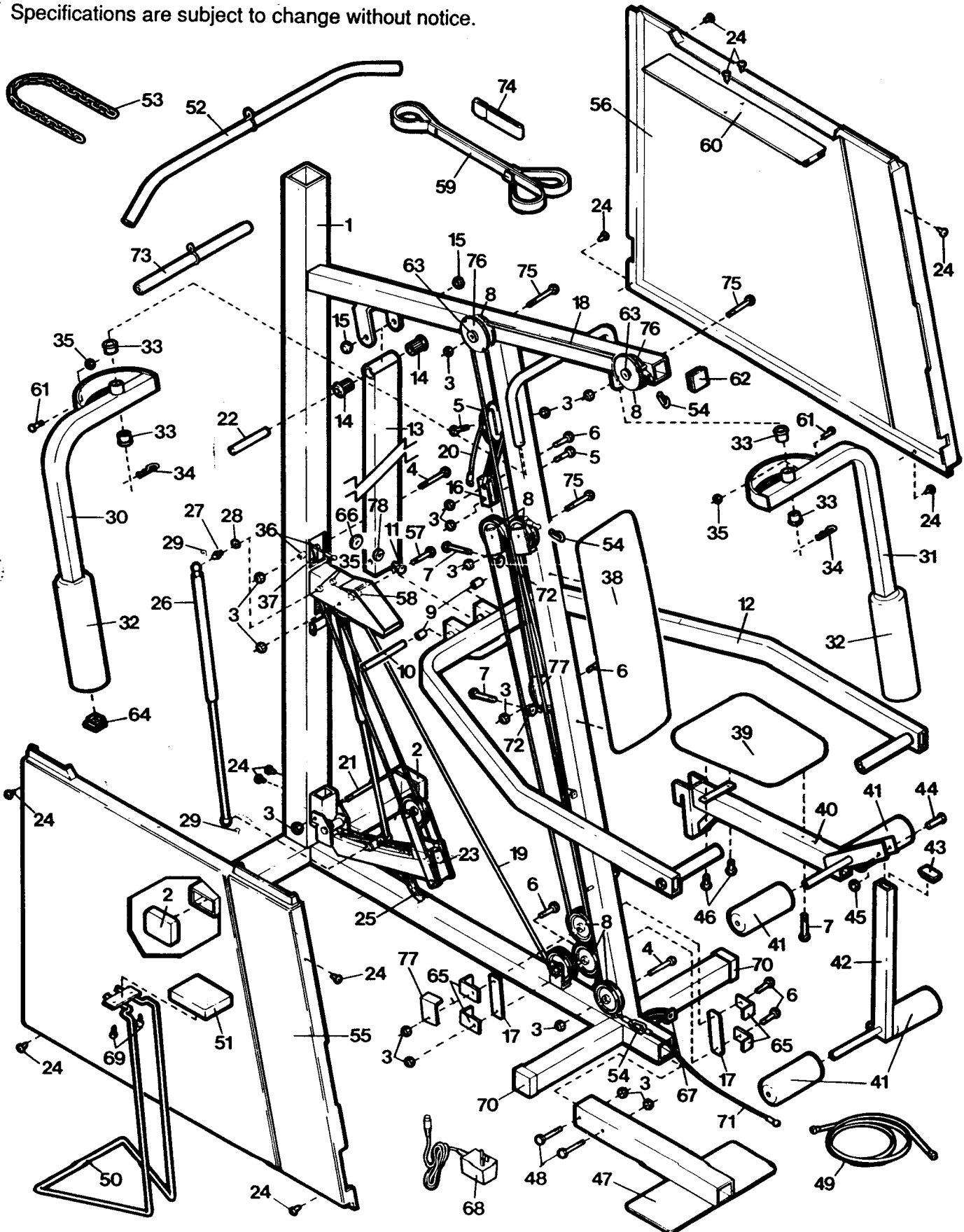

ORDERING REPLACEMENT PARTS

Each EDGE 4001 System has its own MODEL NUMBER. Always mention the MODEL NUMBER when requesting service or repair parts for your EDGE 4001.

All parts listed herein may be ordered through SEARS, ROEBUCK AND CO. SERVICE CENTERS and most SEARS RETAIL STORES.

If parts you need are not stocked locally, your order will be electronically transmitted to a SEARS PARTS DISTRIBUTION CENTER for expedited handling.

WHEN ORDERING REPAIR PARTS, ALWAYS GIVE THE FOLLOWING INFORMATION:

1. The MODEL NUMBER of the product (831.157032).
2. The NAME of the product (Pro Form Edge 4001 Multi-Dimensional Training System).
3. The REORDER NUMBER of the part(s), from page 10 of this manual.
4. The DESCRIPTION of the part(s), from page 10 of this manual.

Your Sears merchandise has added value when you consider that Sears has service units nationwide staffed with Sears trained technicians specifically trained on Sears products, having the parts, tools and equipment to ensure that we meet our pledge to you: "We service what we sell."

FULL 90 DAY WARRANTY ON PARTS

For 90 days from the date of purchase, when proper assembly and maintenance procedures detailed in the Owner's Manual are followed, Sears will, free of charge, repair or replace and install a replacement part for any defective part, when the EDGE 4001 System is used in a normal manner.

This warranty does not apply when the Edge 4001 System is used for commercial or rental purposes.

SERVICE IS AVAILABLE SIMPLY BY RETURNING THE EDGE 4001 SYSTEM TO YOUR NEAREST SEARS SERVICE CENTER/DEPARTMENT IN THE UNITED STATES.

This warranty gives you specific legal rights, and you may also have other rights which vary from state to state.

SEARS, ROEBUCK AND CO., DEPT. 731CR-W, CHICAGO, IL 60684