

BLUE EMBER GRILLS

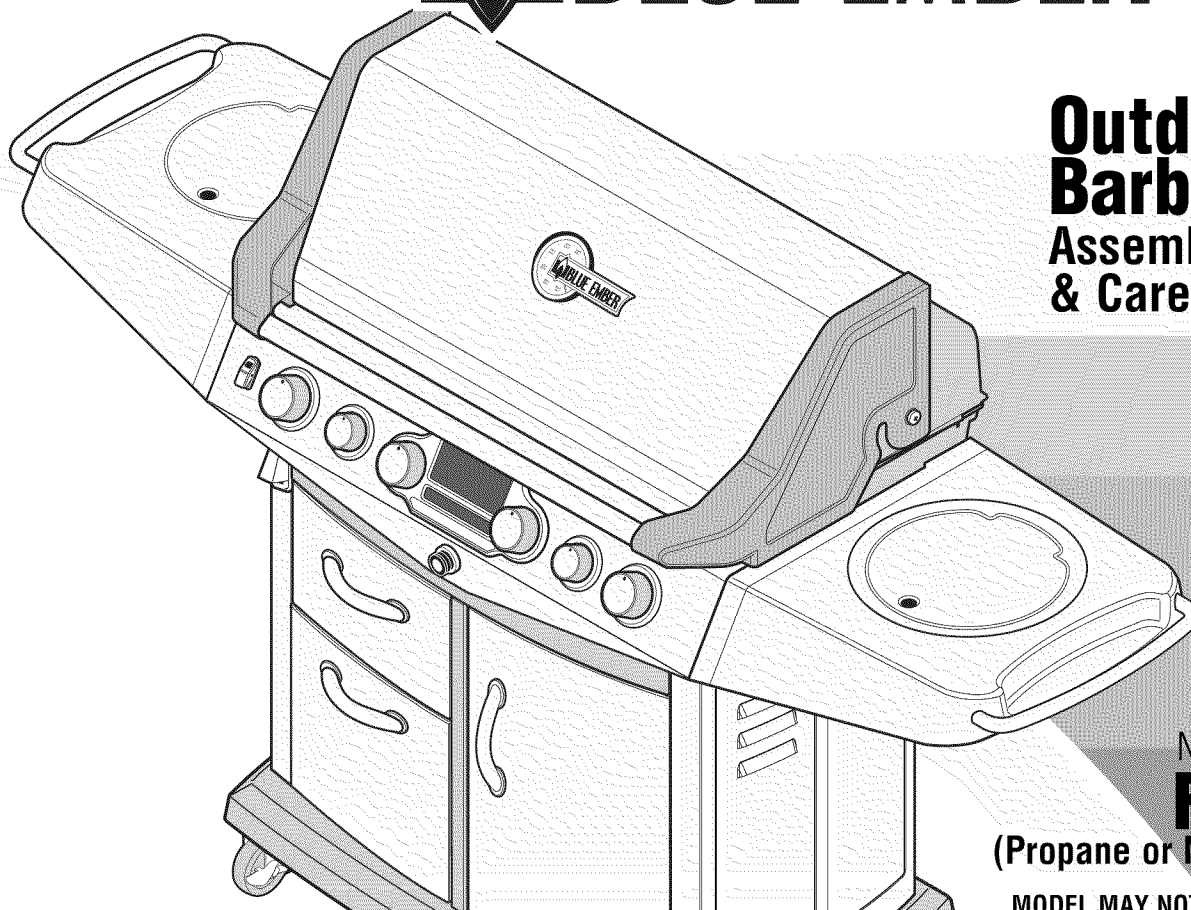

Outdoor Gas Barbeque/Grill Assembly manual / Use & Care



MODEL
FGQ65079
(Propane or Natural Gas Series)

MODEL MAY NOT BE EXACTLY AS SHOWN.

WARNING!

Hazardous Fire or Explosion may result if these instructions are ignored.

It is the user's responsibility to see that this barbecue is properly assembled, installed, maintained and cared for. Failure to follow instructions in this manual could result in serious bodily injury and/or property damage. **Any modification to the grill is dangerous and is not permitted.**

CAUTION

some parts may contain sharp edges -especially if noted in the manual. Wear protective gloves if necessary.

WARRANTY INFORMATION

Full Model No. from outer carton: _____

Date Purchased: _____

Serial Number
(from rating plate): _____

SAVE THIS MANUAL FOR FUTURE REFERENCE

Installer must leave instructions with the consumer for future reference.

KEEP YOUR RECEIPT AS PROOF OF PURCHASE TO VALIDATE THE WARRANTY. ATTACH YOUR RECEIPT TO THE INSIDE COVER OF THIS MANUAL FOR EASY REFERENCE.

THIS APPLIANCE IS FOR OUTDOOR USE ONLY

DANGER!

IF YOU SMELL GAS:

1. Shut off gas supply to appliance.
2. Extinguish any open flame.
3. Open lid.
4. If odour continues, keep away from the appliance and immediately call your gas supplier or your fire department.

WARNING!

- Do not store use gasoline or other flammable liquids or vapours in the vicinity of this or any other appliance.
- An LP cylinder not connected for use shall not be stored in the vicinity of this or any other appliance.

www.blueembergrills.com

Manufactured for

In CANADA: **1-888-267-2159**

Fiesta Barbeques A Division of Wolfedale Engineering Ltd
2 Walker Drive, Brampton, Ontario, L6T 5E1 Canada

In USA: **1-800-396-3838**

Fiesta Gas Grills, LLC.

One Fiesta Drive Dickson, TN. USA 37033

SP5487C-37

THANK YOU FOR PURCHASING THIS BARBEQUE

We are dedicated to creating the ultimate barbeque experience by providing you with all the right tools, starting with this manual. It is important to read through the entire booklet prior to using your barbeque to ensure you fully understand all of the features and how to operate your barbeque for optimum performance.

Please retain this manual for the lifetime of your barbeque after recording the serial and model number in the appropriate space allocated on the front cover.

In Canada

- **The serial number** can be found on the silver rating plate located on rear of the bottom pan resin. Serial numbers are 8 digits long e.g. 02123456
- **The full model number** can be found on the white label of your barbeque box or a partial model number is located above the serial number on the silver rating plate.

In USA

- **The serial number** can be found on the silver rating plate located on rear of the bottom pan resin. Serial numbers are 9 digits long e.g. 08U123456
- **The full model number** can be found on the white label of your barbeque box or above the serial number on the silver rating plate.

TABLE OF CONTENTS

Getting Familiar With Your Barbeque . . . 3

Caring For Your Equipment 3

- Installation
- Electrical Caution
- L.P. Gas Cylinder
- Hose & Regulator

Cleaning & Maintenance 7

- Perform A Leak Test
- Cleaning Venturi Tubes
- Cleaning Other Parts of Your Appliance
- Storage

Using Your Appliance Correctly 9

- Getting Familiar with the Controls
- Lighting
- Re-Lighting
- Shutting Down
- Breaking In Your Barbeque
- Cooking Techniques
- Providing Power to your Barbeque

Trouble Shooting Guide 15

Warranty Information 16



FOR RESIDENTIAL USE ONLY. DO NOT USE FOR COMMERCIAL COOKING.



Combustion by-products produced when using this product contain chemicals known to the state of California to cause cancer, birth defects, or other reproductive harm.

SAFETY SYMBOLS

The symbols and boxes shown below explain what each heading means. Read and follow all of the messages found throughout the manual.



DANGER: INDICATES A IMMINENTLY HAZARDOUS SITUATION WHICH, IF NOT AVOIDED, WILL RESULT IN DEATH OR SERIOUS INJURY.



WARNING: INDICATES AN POTENTIALLY HAZARDOUS SITUATION WHICH, IF NOT AVOIDED, COULD RESULT IN DEATH OR SERIOUS INJURY.



CAUTION: INDICATES AN POTENTIALLY HAZARDOUS SITUATION, OR UNSAFE PRACTICE WHICH, IF NOT AVOIDED, COULD RESULT IN MINOR OR MODERATE INJURY.

FOR YOUR OWN SAFETY:

- Only use your barbeque OUTDOORS in a well-ventilated area and shall not be used in a building garage or any other enclosed area – preferably 3m (10 feet) from your residence or any outbuildings.
- Always keep the area around your barbeque clear of any combustible materials, gasoline, or other flammable liquids.
- Keep the ventilation opening(s) of the cylinder enclosure free and clear from debris.
- **DO NOT** operate this barbeque under overhead or unprotected combustible construction.
- **DO NOT** obstruct the flow of combustion and ventilation air to the barbeque.
- **DO NOT** use in garages, sheds, breezeways, or other enclosed areas.
- **DO NOT** store a spare L.P. (propane) cylinder under or near your barbeque.
- **DO NOT** leave your barbeque unattended while in operation.
- **DO NOT** allow children to operate or play near your barbeque.
- **DO NOT** use while under the influence of alcohol or drugs.
- **DO NOT** install/use in or on recreational vehicles and/or boats



DO NOT USE CHARCOAL OR CERAMIC BRIQUETS IN THIS GAS GRILL, THEY ARE NOT REQUIRED.



IF THE ABOVE INSTRUCTIONS ARE NOT FOLLOWED EXACTLY, A FIRE CAUSING DEATH OR SERIOUS INJURY MAY OCCUR.

GETTING FAMILIAR WITH YOUR BARBEQUE



DO NOT USE YOUR BARBEQUE UNTIL YOU HAVE READ AND UNDERSTOOD ALL THE INFORMATION IN THIS MANUAL. IT IS EXTREMELY IMPORTANT TO BE SURE THAT:

BEFORE YOU USE THIS APPLIANCE

- Ensure your barbeque is properly assembled.
- Ensure there are no leaks in the gas supply system (see 'Leak Testing' section).
- Ensure the burner is properly assembled with the venturi tubes seated over the valve outlets (Figure 1) and there are no blockages present in the venturi tubes (see 'Cleaning Venturi Tubes' Section).
- Ensure all electrical supply cords and/or gas supply hoses are kept away from all or any heated surfaces.
- Ensure your barbeque is positioned in a safe location (see 'Installation' section). **Figure 2.**
- Ensure valve outlets (orifices) are assembled 1 cm (3/8") into the venturi tubes.
- Check to see that the valve outlets and venturi tubes are parallel to the bottom of the base casting of your appliance.

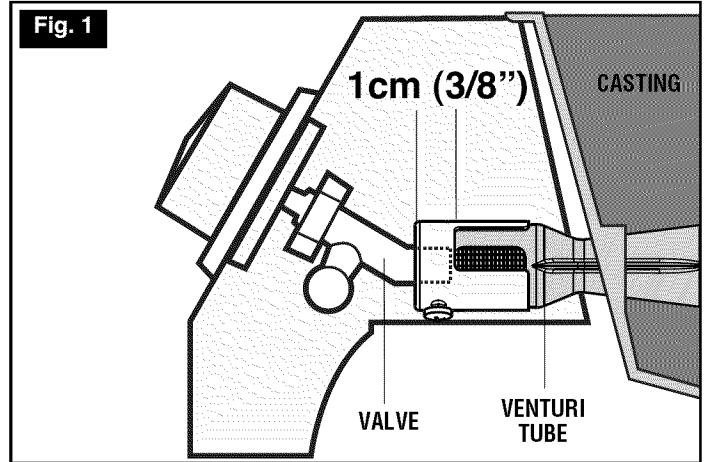

WARNING
FAILURE TO ENSURE THE ABOVE MAY RESULT IN A HAZARDOUS FIRE OR EXPLOSION CAUSING SERIOUS BODILY INJURY AND/OR PROPERTY DAMAGE.

CARING FOR YOUR EQUIPMENT

INSTALLATION

THE INSTALLATION OF THIS APPLIANCE MUST CONFORM WITH LOCAL CODES OR, IN THE ABSENCE OF LOCAL CODES:

- with either the National Fuel Gas Code ANSI Z223.1/NFPA 54, Natural Gas and Propane Installation Code, CSA B149.1, or Propane Storage and Handling Code, B149.2, or the Standard for Recreational Vehicles, ANSI A 119.2/NFPA 119.2, and CSA Z240 RV Series, Recreational Vehicle Code, as applicable.
- Handling and storage of LP cylinders must conform to LP Gas Code NFPA/ANSI 58. Grill is not for use in or on recreational vehicles and/or boats.
- All electrical accessories (such as rotisserie) must be electrically grounded in accordance with local codes CSA C22.1 or National Electrical Code, ANSI/NFPA 70. Keep any electrical cords and/or fuel supply hoses away from any hot surfaces.
- This grill is safety certified for use in the United States and Canada only. Do not modify for use in any other location. Modification will result in a safety hazard.

APARTMENT DWELLERS

Check with management to learn the requirements and fire codes for using an LP gas grill in your apartment complex. If allowed, use outside on the ground floor with clearances as stated in Figure 2 from walls or rails. Do not use on or under balconies.

WARNING
WHEN DECIDING WHERE TO PLACE YOUR APPLIANCE, FOLLOW THESE MINIMUM CLEARANCE DISTANCES TO ADJACENT COMBUSTIBLE MATERIALS:

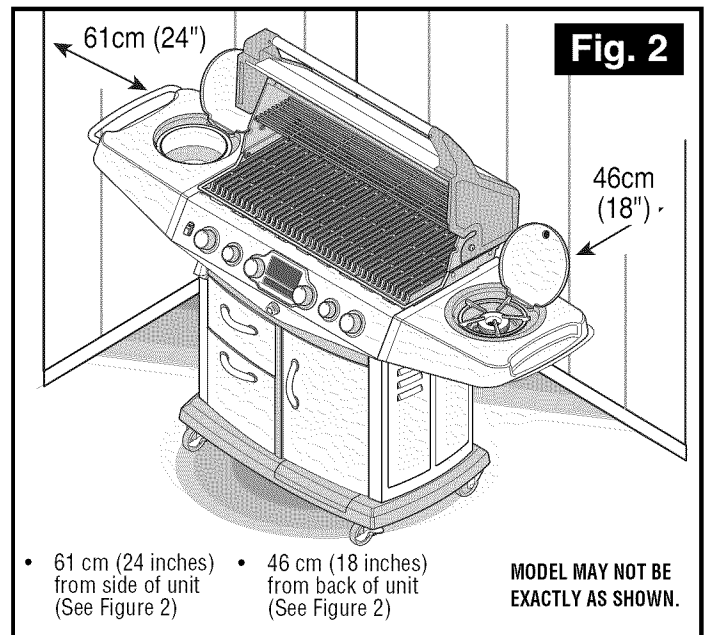

WARNING
DO NOT USE THIS GAS OUTDOOR APPLIANCE UNDER ANY OVERHEAD COMBUSTIBLE CONSTRUCTION.

CARING FOR YOUR EQUIPMENT

ELECTRICAL CAUTION

- If any accessory installed on this barbecue requires an external electrical power source, it must be electrically grounded in accordance with local laws or in the absence of local laws, with the Canadian Electrical Code CSA C22.1 or in the U.S., with the National Electrical Code ANSI-NFPA 70.
- The three-prong plug provides protection against shock hazard and should be plugged directly into a properly grounded three-prong receptacle. Do not cut or remove the grounding prong from this plug.
- To ensure continued protection against risk of electric shock, connect to properly earthed outlets only.
- Ensure all electrical supply cords and fuel supply hoses are kept well away from any heated surfaces.

PROVIDING POWER TO YOUR BARBEQUE

To provide power to the barbecue, plug grounded electrical cord into rear electrical box as shown. (page 34 Fig.17)

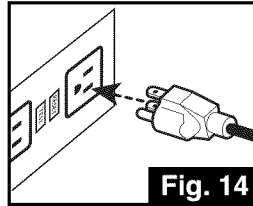

Plug electrical cord into properly grounded GFI (Ground Fault Interrupt) receptacle. If use of an extension cord is required, be sure that it is a minimum 16 AWG, 3 wire well insulated cord, marked for OUTDOOR USE ONLY and properly grounded. (Fig.14)

CAUTION: To ensure continued protection against risk of electric shock, connect to properly earthed outlets only.

L.P. GAS CYLINDER

Gas cylinders manufactured today have mechanisms to provide worry free barbequing year round:

Q.C.C.1 or Type 1-Quick Connect Coupling Valve, ensure fast tank hook-ups requiring only hand tightening. The redundant valve system inhibits the flow of gas to the burner if the connection is not 100% correct.

O.P.D. or Overfill Protection Device prevents accidental gas leaks caused by cylinder "over pressurization", the leading cause of cylinder gas leaks. The float in the tank will automatically stop filling at 80% capacity, leaving a 20% area for the expansion of liquid. Without this safety feature, the relief valve may open and discharge propane, creating a potential safety hazard. An O.P.D. cylinder is easily distinguished by its triangular hand wheel valve. Figure 3)



Look for the Gas Guardian symbol to easily identify propane cylinders with these safety features.

1. SPECIFICATIONS

Self-contained propane gas barbecue systems are designed to be used only with a 9.1 kg (20 lb) propane cylinder, equipped with a Type 1 cylinder valve and incorporating an overfill protection device (O.P.D.). This barbecue cannot be connected to an existing #510 P.O.L. type valve (ones with left-hand threads). The cylinder for your gas barbecue must be constructed and marked in accordance with the specifications of L.P. gas cylinders:

In Canada: The National Standards of Canada CAN/GSA-B339, Cylinders, Spheres and Tubes for Transportation of Dangerous Goods; and Commission.

In the U.S.: U.S. Department of Transportation (D.O.T.)

DO NOT CONNECT TO A PROPANE GAS CYLINDER EXCEEDING THIS CAPACITY, OR USE A CYLINDER WITH ANY OTHER TYPE OF VALVE

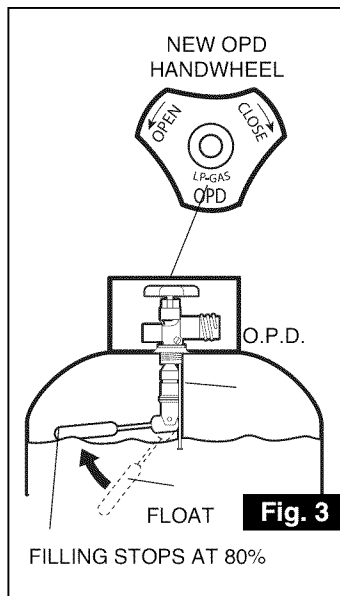

CONNECTION DEVICE.

The Type 1 valve is recognizable by the large external thread on the outlet part of the valve. Standard existing valves do not have these exterior threads. Any attempt to connect a regulator, with other than the:

- i) Mating Type 1 connector (recognized by the large black coupling nut) or
- ii) Standard #510 P.O.L. fitting,

by use of adapters or any other means, could result in damage, fire or injury and may negate the important safety features designed into the Type 1 system. The connection of a #510 P.O.L. fitting will not provide the flow control or temperature shut-off features built into the complete Type 1 system.

We strongly recommend use of a propane cylinder with Q.C.C.1 and O.P.D. safety features.

THE CYLINDER MUST ALSO BE EQUIPPED WITH:

- a. A shut-off valve terminating in a proper cylinder valve outlet specified in current standards:
 - Canada: CSA 1.6-2007 Outdoor Cooking Gas Appliances.
 - U.S.: ANSI Z21.58-2007 Outdoor Cooking Gas Appliances.
- b. A listed overfilling protection device (O.P.D.).
- c. A safety relief valve having direct communication with the vapor space of the cylinder.
- d. A collar to protect the tank shut off valve.
- e. An arrangement for vapor withdrawal.
- f. A bottom ring for securing to tank support assembly.

THE CYLINDER SHOULD NOT EXCEED 472 MM (18 1/2") IN HEIGHT AND 317 MM (12 1/2") IN DIAMETER.

SAFETY:

- Always turn off the cylinder valve tightly when your barbecue is not in use.
- Handle tank valves with care.
- Never connect an unregulated L.P. gas cylinder to your barbecue.
- Never store a spare cylinder under or near your barbecue when in use.
- Never subject any cylinder to excessive heat or direct sunlight.
- Always keep your in-use cylinder securely fastened in an upright position.
- Do not insert any foreign objects into the valve outlet. You may damage the back-check. A damaged back-check can be the source of a leak. Leaking propane may result in explosion, fire, severe personal injury or death.
- Never fill the cylinder beyond 80% full.



IF THE ABOVE INSTRUCTIONS ARE NOT FOLLOWED EXACTLY, A FIRE CAUSING DEATH OR SERIOUS INJURY MAY OCCUR.

TRANSPORTATION AND STORAGE:



WARNING
ALTHOUGH IT IS SAFE WHEN USED PROPERLY, CARELESS HANDLING OF THE PROPANE GAS CYLINDER COULD RESULT IN FIRE, EXPLOSION, AND/OR SERIOUS INJURY.

PROPANE GAS IS HEAVIER THAN AIR, AND WILL COLLECT IN LOW AREAS, INCREASING THE ABOVE RISKS. THEREFORE:

- **ALWAYS** use the cylinder cap provided with your cylinder whenever the cylinder is not connected to your barbeque. (Figure 4)
- **DO NOT** store in a building, garage or any other enclosed area. Store in a well-ventilated area.
- **DO NOT** store near any gas burning apparatus or in any high-heat areas such as a closed car or trunk.
- Transport and store the cylinder in an upright position – do not tip on its side.
- Store out of reach of children.
- **DO NOT** smoke while transporting a cylinder in your vehicle.

WARNING

- **Never fill a cylinder beyond 80% full.**
- **An over filled or improperly stored cylinder is a hazard due to possible gas release from the safety relief valve. This could cause an intense fire with risk of property damage, serious injury or death.**
- **If you see, smell or hear gas escaping, immediately get away from the LP cylinder/appliance and call your fire department.**

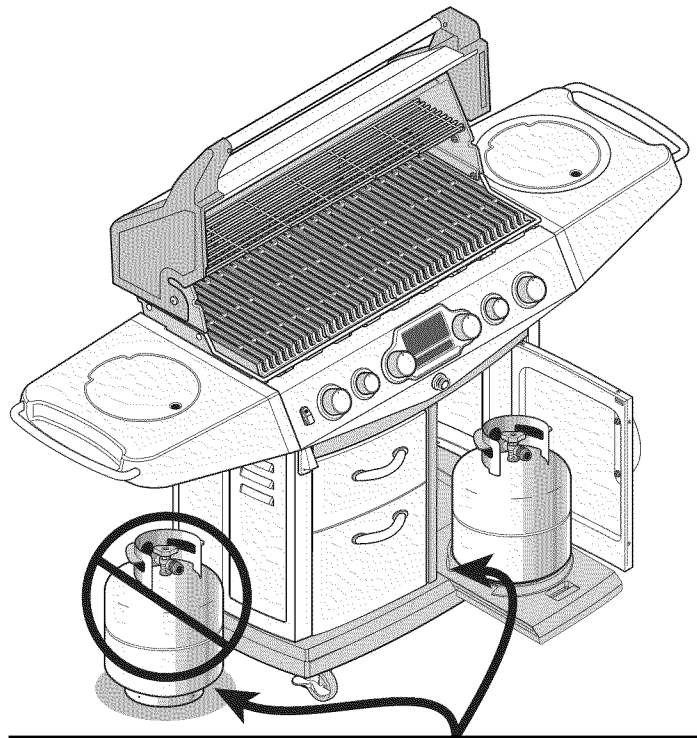

NEVER STORE A SPARE LP CYLINDER UNDER OR NEAR THE APPLIANCE OR IN AN ENCLOSED AREA.

FILLING:

FOR SAFETY REASONS, IF AN OPTIONAL L.P. GAS CYLINDER WAS SUPPLIED WITH YOUR BARBEQUE, IT HAS BEEN SHIPPED EMPTY. THE CYLINDER MUST BE PURGED OF AIR AND FILLED PRIOR TO USING ON YOUR BARBEQUE. WHEN GETTING YOUR CYLINDER FILLED:

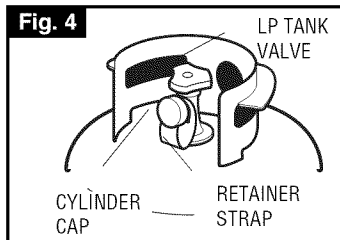

- Allow only a qualified L.P. gas dealer to fill or repair your cylinder.
- **DO NOT** allow the cylinder to be filled beyond 80% full.
- Make sure the L.P. gas dealer checks the cylinder for leaks after filling.



ALWAYS CLOSE LP CYLINDER VALVE AND REMOVE COUPLING NUT BEFORE MOVING LP CYLINDER FROM SPECIFIED OPERATION POSITION.

LP CYLINDER EXCHANGE

Many retailers that sell grills offer you the option of replacing your empty LP cylinder through an exchange service. Use only those reputable exchange companies that inspect, precision fill, test and certify their cylinders. Exchange your cylinder only for an OPD safety feature-equipped cylinder as described in the "LP Cylinder" section of this manual.

- Always keep new and exchanged LP cylinders in upright position during use, transit or storage.
- Leak test new and exchanged LP cylinders BEFORE connecting to grill.



NEVER OPERATE GRILL WITH LP CYLINDER OUT OF CORRECT POSITION SPECIFIED IN ASSEMBLY INSTRUCTIONS.



Do not insert any tool or foreign object into the valve outlet or safety relief valve. You may damage the valve and cause a leak. Leaking propane may result in explosion, fire, severe personal injury, or death.



- **Never attempt to attach this grill to the self-contained LP gas system of a camper trailer or motor home.**
- **Do not use grill until leak-tested.**
- **If a leak is detected at any time, STOP and call the fire department.**
- **If you cannot stop a gas leak, immediately close LP cylinder valve and call LP gas supplier or your fire department!**

HOSE & REGULATOR



WARNING: INDICATES AN POTENTIALLY HAZARDOUS SITUATION WHICH, IF NOT AVOIDED, COULD RESULT IN DEATH OR SERIOUS INJURY.

PROPANE GAS MODELS:

Your barbeque is designed to operate on L.P. (propane) gas at a pressure regulated at 2.74 kPa (11" water column). A regulator preset to this pressure is supplied with the barbeque and **MUST** be used.

This regulator is equipped with the Q.C.C. Type 1, quick connect coupling system, which incorporates the following safety features: (Figure 5)

- It will not allow gas to flow until a positive seal has been made (Figure 6)
- It has a thermal element that will shut off the flow of gas between 115 and 150°C (240 and 300°F)
- It also has a flow-limiting device which, when activated, will restrict the flow of gas to 0.28 cubic metres per hour (10 cubic feet per hour)

Prior to attaching the propane cylinder to the hose and regulator, be sure the cylinder valve and the appliance valves are OFF. The cylinder valve is turned off by rotating the handwheel (see Figure 3) clockwise (left to right) until it stops and all appliance valves should be in the twelve o'clock position. When attaching the regulator to the cylinder, make sure that the small probe in the nipple is centered in the mating Q.C.C. 1 cylinder valve (see Figure 5 & 6). Turn the right hand threaded Q.C.C.1 black nut onto the valve in a clockwise motion until there is a positive stop.

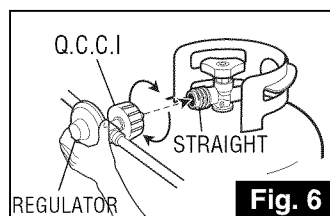
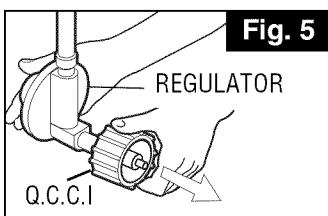

DO NOT USE A WRENCH, HAND TIGHTEN ONLY.

Should the large black thermally sensitive coupling nut be exposed to temperatures above 115 - 150°C, it will soften and allow the regulator probe to disengage from the cylinder valve – thereby shutting off the flow of gas. Should this occur, do not attempt to reconnect the nut. Remove the entire regulator assembly, and replace it with a new one.

The cause of the excessive heat should be determined and corrected before operating your barbeque again. The regulator probe also contains a flow-sensing element, which will limit the flow of gas to the regulator to a manageable amount (0.28 cubic metres/hour) in the event of a hose or regulator rupture. If it is evident that the flow control device has been activated, the cause of the excessive flow should be determined and corrected before using your barbeque again.

NOTE: IMPROPER LIGHTING PROCEDURES CAN CAUSE THE FLOW CONTROL TO ACTIVATE, RESULTING IN REDUCED HEAT OUTPUT. IF THIS IS SUSPECTED, RESET THE FLOW CONTROL BY SHUTTING OFF ALL BURNER CONTROLS AND THE CYLINDER VALVE. WAIT 30 SECONDS, THEN TURN THE CYLINDER VALVE ON EXTREMELY SLOWLY - WAIT 5 SECONDS AND TURN THE BURNER VALVE ON AND LIGHT AS NORMAL.

- Never connect a propane gas barbeque to an unregulated propane gas supply or **any other gas**. Do not attempt to alter the hose or regulator in any way.
- The connection fitting must be protected when disconnected from the propane tank. If the fitting is allowed to drag on the ground, nicks and scratches could occur resulting in a leak when connected to the propane tank.

PROPANE AND NATURAL GAS MODELS:

- Do not allow any grease (or other hot material) to fall onto the hose, or allow the hose to come in contact with any hot surfaces of the barbeque.
- Visually inspect the entire length of the hose assembly before each use of the barbeque. If it is evident there is excessive abrasion/wear, or the hose is cut, it must be replaced prior to using your barbeque. Only the hose assembly as specified in the Parts List should be used.
- Follow the '**LEAK TEST**' instructions before lighting your barbeque for the first time, every time a propane cylinder is refilled, if any gas component is changed, if the regulator flow-limiting device has been activated, after prolonged periods of storage or non-use or at least once per season.

NATURAL GAS MODELS:

- Never use with propane, or **any other gases**.
- The appliance and its individual shut-off valve must be disconnected from the gas supply piping during any pressure testing of the system at test pressure in excess of 3.5 kPa (1/2 p.s.i.).
- The appliance must be isolated from the gas supply piping system by closing its individual manual shut-off valve during any pressure testing of the gas supply piping system at pressures equal to or less than 3.5 kPa (1/2 p.s.i.).
- The gas supply hose must be a minimum of 3.1 m (10 ft) and a maximum of 3.6 m (12 ft). Always disconnect hose at quick connect coupling when storing your barbeque.
- Inspect and clean quick connect coupling, and keep it protected when it's not in use.

WARNING

FAILURE TO ENSURE THE ABOVE MAY RESULT IN A HAZARDOUS FIRE OR EXPLOSION CAUSING SERIOUS BODILY INJURY AND/OR PROPERTY DAMAGE.

WARNING

DO NOT ATTEMPT TO REPAIR OR ALTER THE HOSE/VALVE/REGULATOR FOR ANY "ASSUMED" DEFECT. ANY MODIFICATION TO THIS ASSEMBLY WILL VOID YOUR WARRANTY AND CREATE THE RISK OF A GAS LEAK AND FIRE. USE ONLY AUTHORIZED REPLACEMENT PARTS SUPPLIED BY MANUFACTURER.

CLEANING & MAINTENANCE

To keep your barbeque working at its peak efficiency as well as contribute to the safe operation of this unit, perform all of the operations below at least once a year - preferably at the start of each cooking season.

PERFORM A LEAK TEST

A leak test ensures that there are no gas leaks prior to lighting your barbeque.

WHEN A LEAK TEST MUST BE PERFORMED:

- Before lighting your barbeque for the first time
- Every time the propane cylinder is refilled
- If any gas component is changed
- At a minimum once per season
- After prolonged period of storage or non-use
- If the regulator flow-limiting device has been activated

The leak test should be performed in a well-ventilated area away from any open flame, heat or ignition sources.

DO NOT USE A MATCH, OPEN FLAME OR SMOKE DURING LEAK TESTING.

WHAT YOU'LL NEED FOR TESTING:

1. A mixture of 50% liquid dish soap and 50% water.
2. A brush or cloth to apply the mixture.

AREAS TO TEST ON A PROPANE BARBEQUE:

- All propane cylinder welds (see Figure 7A)
- Propane cylinder valve – including threads into cylinder (Figure 7B)
- Regulator fitting and propane cylinder connection (Figure 7B)
- All hose connections (Figure 7C) including side burner and Rotisserie tubing, if equipped (Figure 7D)
- All valve connections (Figure 7C & D)

AREAS TO TEST ON NATURAL GAS BARBEQUES:

- All hose connections (Figure 7C)
- All valve connections (Figure 7C & 7D)

HOW TO DO THE TESTING:

1. With the barbeque console control knobs in the 'OFF' position, twist the valve on your propane cylinder 1 turn, or the main natural gas valve on.

DO NOT IGNITE THE BURNERS WHILE PERFORMING THE LEAK CHECK.

2. Brush your soap and water solution on all connections and components as outlined above.
3. Observe each place for growing bubbles, which indicate that a leak is present.
4. Shut off the flow of gas while fixing the leak. Tighten any leaking connection and repeat test until no leaks are detected.
5. If the leak(s) cannot be stopped **DO NOT USE. Shut off the fuel source at the valve immediately (if appropriate, remove propane cylinder). Call a certified gas appliance service person, or a gas dealer for proper repairs.**

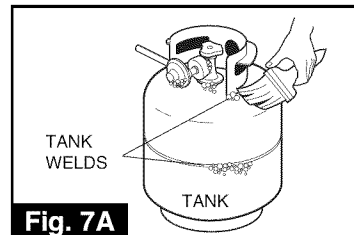

Fig. 7A

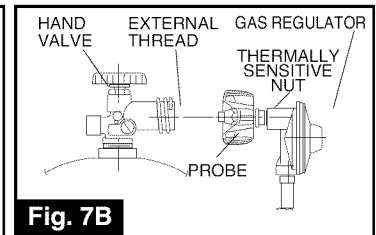

Fig. 7B

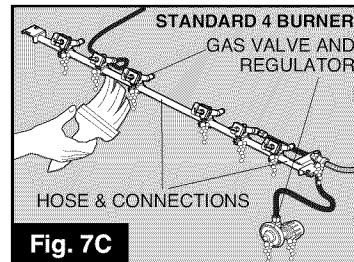

Fig. 7C

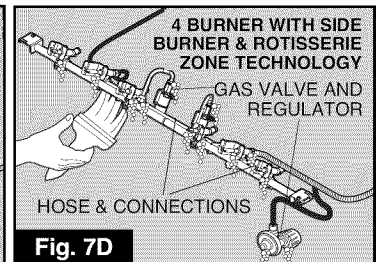

Fig. 7D



WARNING

IF THE ABOVE INSTRUCTIONS ARE NOT FOLLOWED EXACTLY, A FIRE CAUSING DEATH OR SERIOUS INJURY MAY OCCUR.

CLEANING VENTURI TUBES

Periodic cleaning of the venturi tubes is recommended for optimum burner performance, especially after prolonged storage or a period of non-use.

How to Clean:

- Remove the burner (refer to 'ASSEMBLY PROCEDURE').
- Use a venturi cleaning brush and insert the brush into the venturi tube 1 inch at a time, then remove to prevent moving the debris upwards (Figure 8).
- As you remove the brush head inspect and discard any debris
- Continue this procedure until the entire lengths of all venturi tubes are free of debris.
- Reinstall burner (as per assembly instructions), ensure the venturi tubes are seated over the valve orifices (Figure 1).
- Perform a Leak Test.

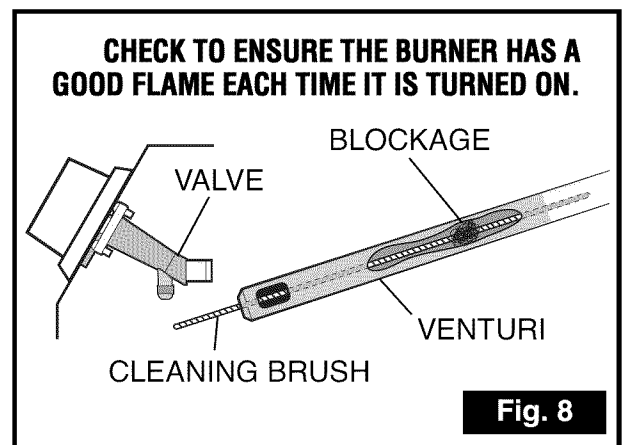
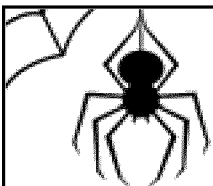

Fig. 8



WARNING

It is possible that very small insects could make webs or nest in the venturi tubes, as they are naturally attracted to the smell of gas. This will partially or completely block the flow of gas through the venturi and is indicated by a smoky yellow flame, and/or a burner that is difficult or impossible to light. Ultimately, it may cause the gas to burn outside the venturis, which can cause a fire resulting in damage to your barbeque and potential personal injury. **IF THIS HAPPENS IMMEDIATELY SHUT OFF THE PROPANE AT CYLINDER.** When the barbeque has cooled, follow the "How to Clean" steps above.

CLEANING OTHER PARTS OF YOUR APPLIANCE

General Grill Cleaning: Do not mistake brown or black accumulation of grease and smoke for paint. Interiors of gas grills are not painted at the factory (and should never be painted). Apply a strong solution of detergent and water or use a grill cleaner with scrub brush on insides of grill lid and bottom. Rinse and allow to completely air dry. Do not apply a caustic grill/oven cleaner to painted surfaces.

BURNER:

At least twice a year, clean your burner when cleaning the venturi tubes. The burner can be gently scraped clean with a brass bristle brush. Ensure that all burner ports (openings) are clear (**DO NOT ENLARGE BURNER PORTS**). If you find cracks, abnormal holes, or damage caused by corrosion during your inspection and cleaning, replace burner. (**SEE WARRANTY**).

IGNITOR:

Clean the ignitor clip lightly using a wire brush to remove rust and grease. **DO NOT USE WATER OR CLEAN THE ELECTRODE WITH THE WIRE BRUSH.** Visually inspect the ceramic of the electrode for cracks. The electrode can be wiped with a soft cloth if necessary. If a crack is found, a replacement ignitor system will be required.

CLEANING GRIDS:

After each use, scrub the cooking grids with a stiff long-handled brass brush. Do not use steel brushes, as they can scratch the nickel or porcelain coating. Grids can also be washed with mild detergent. Never use commercial oven cleaners. If rust appears on your cooking grids, remove the rust with a scrub pad and coat the grid with some cooking oil. If excessive wear is evident, you might want to replace or upgrade your cooking grid.

PORCELAIN SURFACES:

Because of glass-like composition, most residue can be wiped away with baking soda/water solution or specially formulated cleaner. Use nonabrasive scouring powder for stubborn stains.

PAINTED SURFACES:

Wash with mild detergent or nonabrasive cleaner and warm soapy water. Wipe dry with a soft nonabrasive cloth.

STAINLESS STEEL SURFACES:

To maintain your grill's high quality appearance, wash with mild detergent and warm soapy water and wipe dry with a soft cloth after each use. Baked-on grease deposits may require the use of an abrasive plastic cleaning pad. Use only in direction of brushed finish to avoid damage. Do not use abrasive pad on areas with graphics.

SIDE SHELVES:

Metal Shelves: Use any household cleaner, except those containing acid or mineral spirits. Be sure to rinse well after cleaning.

DO NOT USE AS A CUTTING BOARD.

Plastic Shelves: Wash with warm soapy water and wipe dry. Do not use citrisol, abrasive cleaners, degreasers or a concentrated grill cleaner on plastic parts. Damage to and failure of parts can result.

PLASTIC PARTS:

Wash with warm soapy water and wipe dry. Do not use citrisol, abrasive cleaners, degreasers or a concentrated grill cleaner on plastic parts. Damage to and failure of parts can result.

CASTING INTERIOR AND WARMING RACK:

At least once a year remove all components from inside your barbeque. Loosen any cooking residue with a scraping tool for large particles and a brass barbeque brush for smaller particles. Scrub with hot water and a strong detergent, then rinse thoroughly or spray barbeque degreaser liberally on all interior surfaces. Be sure to use gloves and eye protection. Let stand for 10 minutes, scrape off residue and repeat if required. Rinse thoroughly with water. Replace all components as outlined in the assembly instructions. **DO NOT USE DEGREASER ON PAINTED OR PLASTIC SURFACES. DO NOT ALLOW EXCESSIVE GREASE OR OTHER RESIDUE TO BUILD UP ON YOUR COOKING SYSTEM AS A FIRE MAY RESULT.**

GREASE PAN AND GREASE TRAY INSERT: The grease tray and insert are located on the bottom of the base casting, below the grease pan, and immediately below the hole through which any grease will drain. The grease pan tray insert should be checked and replaced and clean prior to each use to prevent grease from overflowing.

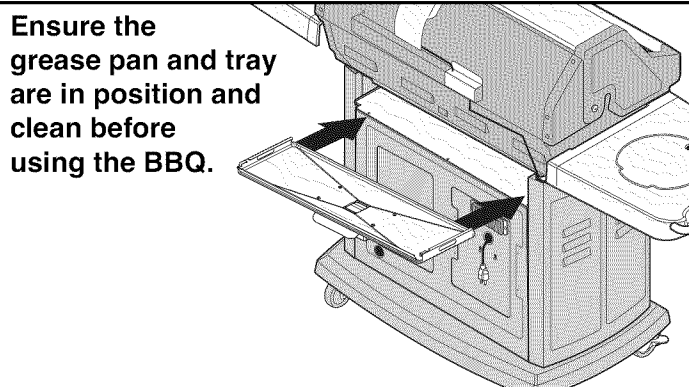

Ensure the grease pan and tray are in position and clean before using the BBQ.



Ensure that grease pan and tray are emptied after each use. If excess grease is allowed to accumulate, a possible fire causing property damage or serious injury may occur.

COVER YOUR BARBEQUE WHEN IT IS NOT IN USE TO PROTECT THE SHELVES FROM THE OUTDOOR ELEMENTS.

STORAGE

More people are discovering the pleasure of year round barbequing. However, if you choose to store your barbeque for the winter or any extended length of time, follow these steps:

- Clean the cooking grids, then oil lightly with cooking oil, wrap in paper and then store the cooking grids indoors.
 - Follow the same cleaning method above for the burners and any warming racks.
 - Cover the barbeque if it is left outdoors.
 - When the barbeque is not in use, the gas must be turned off at the L.P. cylinder valve or main shut off valve, and stored outdoors in a well-ventilated area.
1. With a **Propane** appliance you can store the barbeque inside, PROVIDED the cylinder is removed from the barbeque and stored outdoors in a well-ventilated area, out of the reach of children. When the cylinder is disconnected from the barbeque, ensure the cylinder valve safety cap is placed over valve opening (fig. 4).
 2. With a **Natural Gas** appliance, the gas must be turned off at the individual gas shut off valve and the hose must be disconnected from the gas supply piping system before storing the barbeque indoors. Install plastic covers to quick connect fittings.

After a period of storage or non-use a leak test should be performed and the burner venturis cleaned prior to use.



NEVER STORE A SPARE LP CYLINDER UNDER OR NEAR THE APPLIANCE OR IN AN ENCLOSED AREA.

USING YOUR APPLIANCE CORRECTLY

BEFORE USING YOUR APPLIANCE READ ALL INSTRUCTIONS IN THIS MANUAL AND IQUEINSTRUCTION MANUAL USER GUIDE.

Fig. 9A

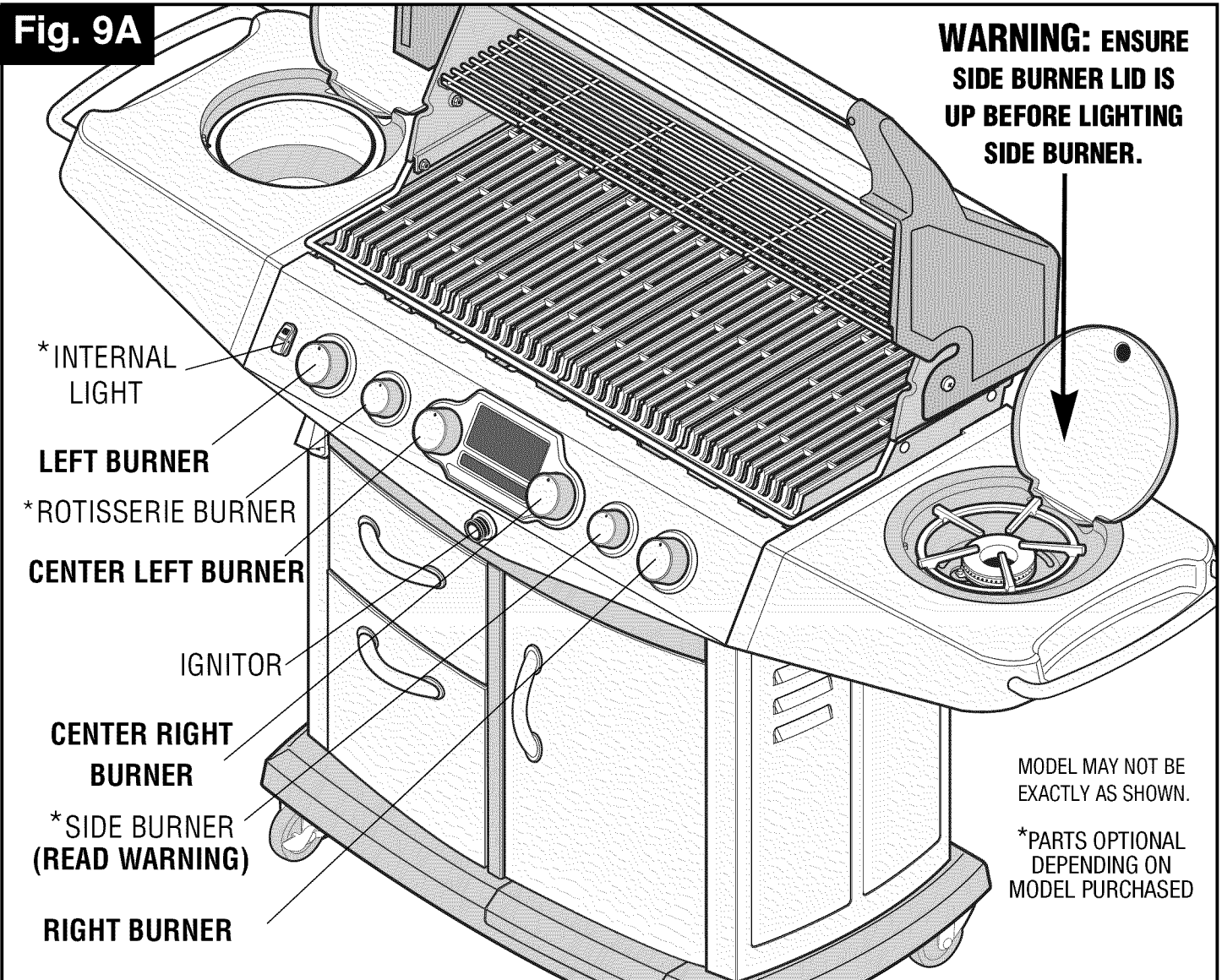

GETTING FAMILIAR WITH THE CONTROLS

Prior to lighting your barbecue, ensure you become Familiar with the controls (see above). On barbecues with quad main controls, the large right control knob operates the right most burner, the large center right control knob operates the right center burner the large left center control knob operates the left center burner, And the large left control knob operates the left most burner. (Figure 9A) If equipped with optional side and roisserie burners, the right small knob operates the side burner the small left knob operates the rear rotisserie burner. (Figure 9A)

IGNITOR BATTERY

Ensure AA BATTERY is installed correctly, put - (negative) side of battery in first. (Figure 9B)



WARNING

DO NOT LIGHT SIDE BURNER WITH LID DOWN. FAILURE TO DO SO MAY CAUSE SERIOUS BODILY INJURY AND/OR PROPERTY DAMAGE.

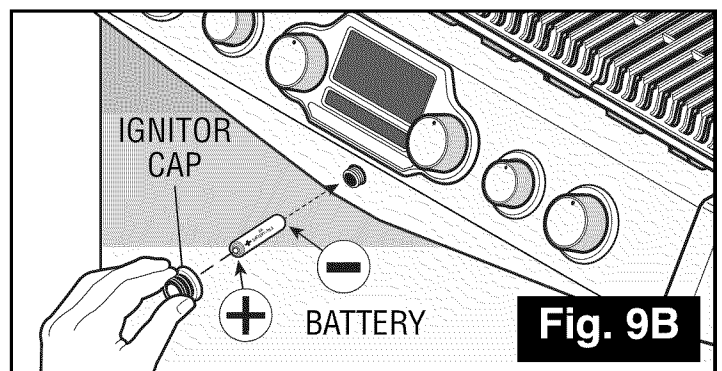

LIGHTING

Prior to lighting your barbecue, visually check all hoses before each use for nicks, cracking, abrasions or cuts. If the hose is found to be damaged in any way, **DO NOT USE YOUR BARBEQUE.**

A replacement hose and regulator is required (see 'PARTS LIST' in Assembly Brochure).

IMPORTANT

- Always raise the barbecue lid before lighting.
- Do not lean over the barbecue when lighting the burner.
- Visually check the flames every time you light your barbecue (Figure 10). If the flame is abnormally small or a smoky yellow - shut off the barbecue and check the venturi tubes for blockage (see Figure 8) or refer to the Troubleshooting Guide.

MAIN BURNERS USING THE IGNITOR (Figure 11A)

1. OPEN THE LID BEFORE LIGHTING.
2. Turn off all of the burner control knobs and close the gas supply valve.
3. Open the gas supply valve and wait 5 seconds.
4. Push in and turn a single main burner control knob to 'HIGH'. All other control knobs should be in the "OFF" position.
5. Depress the ignitor, repeat if necessary.
6. If the burner does not light immediately (within five seconds), turn burner control knob off and wait 5 minutes to clear the gas.
7. Repeat steps 1 to 6. If burner still fails to light, refer to **Troubleshooting Guide** to determine cause and solution, or try the Match Lighting procedure (Fig. 11B).

LIGHTING THE OTHER MAIN BURNERS

Once one burner has been lit, push in and turn the adjacent control knob to 'HIGH'. The unlit burner will light automatically.

MATCH LIGHTING PROCEDURE

1. Open the lid before lighting.
2. Place an ignited lighter or lit match through the lighting hole, approx. 1.25 cm (1/2") from burner. (See Figure 11B)
3. Push in and turn the left burner control knob to 'HIGH'. The burner should light immediately (within five seconds). If it does not, extinguish the lighter or match, turn the control knob to off, and wait 5 minutes to clear the gas.
4. Repeat steps 1 to 3. If burner fails to light, refer to the Troubleshooting Guide to determine cause and solution.
5. Once left hand burner is lit, light remaining burners in this sequence: left burner, left center burner, right center burner, then right burner.

LIGHTING THE OTHER MAIN BURNERS

Once one burner has been lit, push in and turn the adjacent control knob to 'HIGH'. The unlit burner will light automatically.

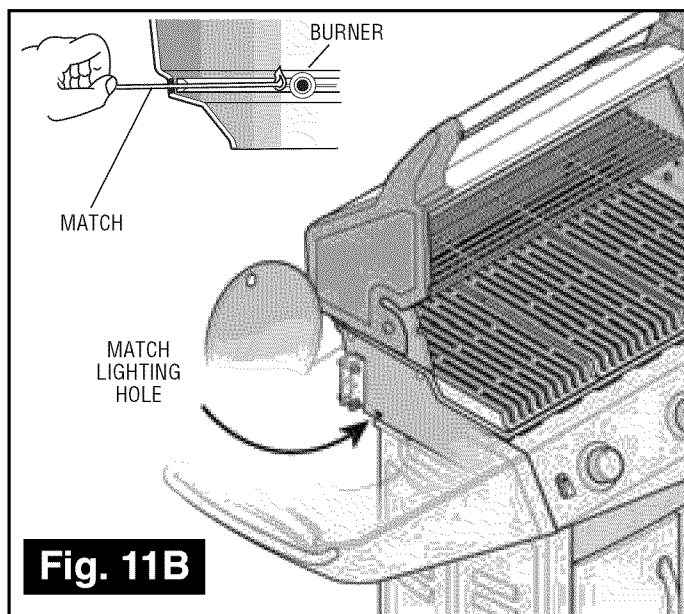
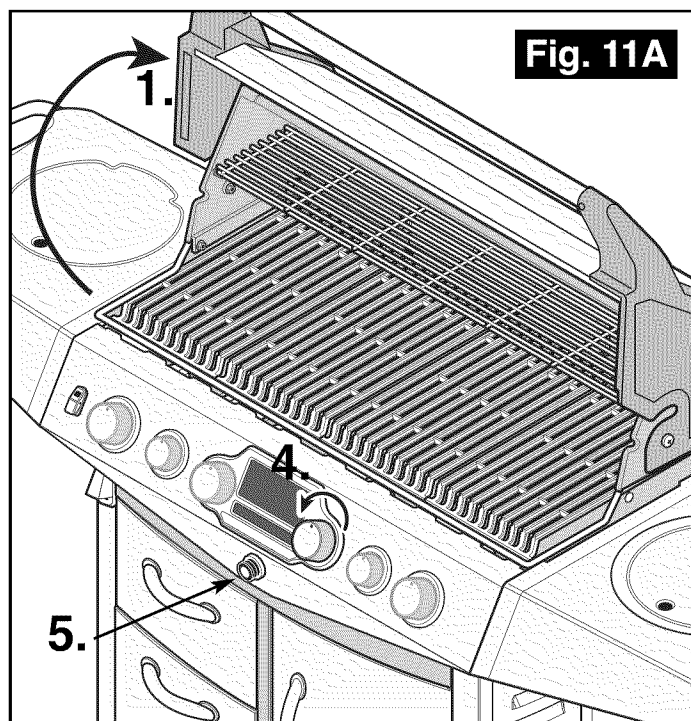
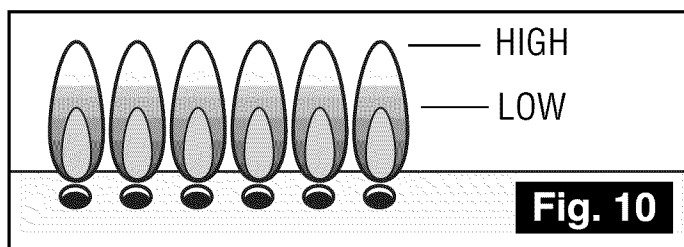

SIDE BURNER

(OPTIONAL)

USING THE IGNITOR

1. RAISE SIDE BURNER LID.
2. Push in and turn the side burner control knob to 'HIGH'.
3. Depress ignitor. Repeat if necessary (Figure 12A).
4. If burner does not light immediately (within five seconds), turn the burner control knob off, and wait 5 minutes to clear the gas.
5. Repeat steps 1 to 4. If burner still fails to light, refer to the Troubleshooting Guide to determine cause and solution, or try the match lighting procedure below.



WARNING

DO NOT LIGHT SIDE BURNER WITH LID DOWN. FAILURE TO DO SO MAY CAUSE SERIOUS BODILY INJURY AND/OR PROPERTY DAMAGE.

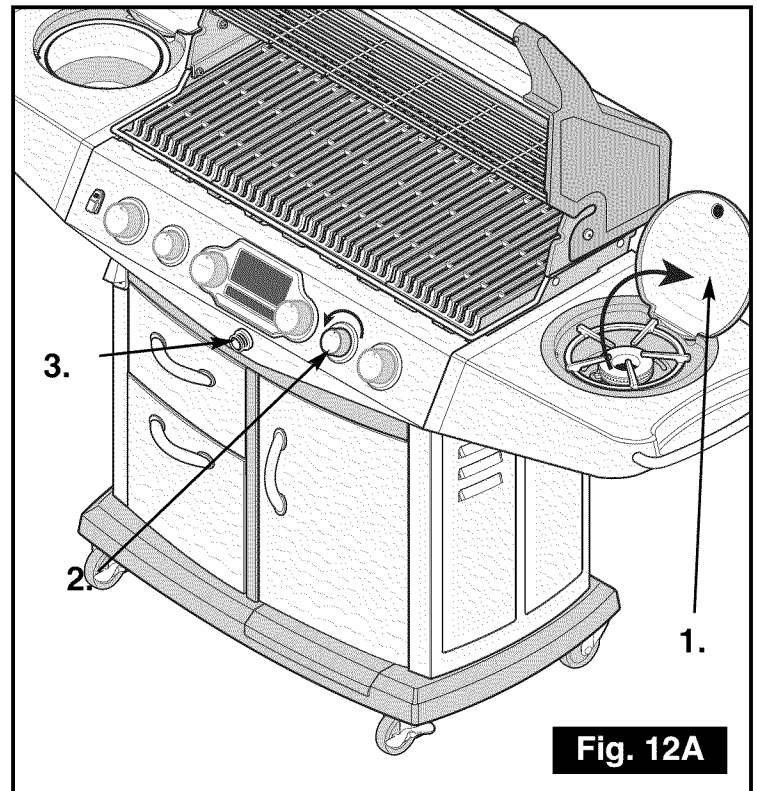

SIDE BURNER MATCH LIGHTING PROCEDURE

1. RAISE SIDE BURNER LID.
2. Place an ignited lighter or lit match near the ports, approximately 1/2" (1.25 cm) from burner (Figure 12B).
3. Push in and turn the side burner control knob to 'HIGH'. The burner should light immediately (within five seconds). If it does not, extinguish the lighter or match, turn the control knob off, and wait 5 minutes for the gas to clear.
4. Repeat steps 1 and 3. If burner still fails to light, refer to the Troubleshooting Guide to determine the cause and solution.

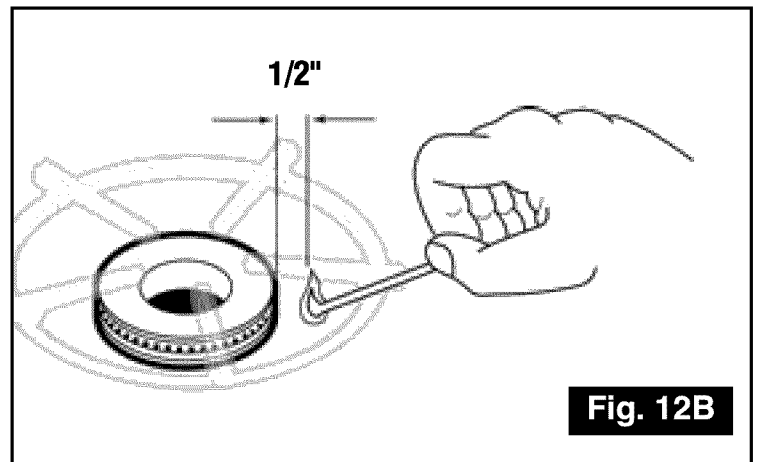

SIDE BURNER COOKING POTS

1. Ensure pot size is a maximum size of 9" wide only (Figure 12C).
2. Maximum weight to be used on side burner should not exceed 20 lbs (9 kg)

PROPANE MODELS ONLY

If the heat output from the burner(s) seem abnormally low, it may be caused by the regulator flow-limiting device being activated by a leak in the gas system, or improper lighting procedures. If this is suspected, shut off the cylinder valve and all burner valves. Perform a leak test to determine if a leak has caused the flow-limiting device to activate. If the leak test is negative, then carefully follow the lighting procedures step-by-step, ensuring all valves (including tank) are **off** before starting.

RELIGHTING SAFETY WARNING

If the burner flame goes out when your barbeque is in operation, immediately turn off the control valves. Wait five minutes for the gas to clear before attempting to relight the burner. If the problem persists, refer to the Troubleshooting Guide.

NOTE: WHEN USING THE SIDE BURNER, THE MAXIMUM POT SIZE IS 9" WIDE.

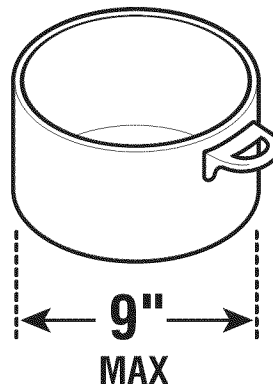

NOTE: MAXIMUM WEIGHT FOR SIDE BURNER 20 lbs (9 kg)

Fig. 12C

REAR ROTISSERIE BURNER (OPTIONAL)

USING THE IGNITOR

1. OPEN THE LID BEFORE LIGHTING.
2. Push in and turn the rotisserie control knob to 'HIGH'.
3. Depress ignitor. Repeat if necessary (see Figure 12D).
4. If burner does not light immediately (within five seconds), turn the burner control knob off, and wait 5 minutes to clear the gas.
5. Repeat steps 1 to 4. If burner still fails to light, refer to the Troubleshooting Guide to determine cause and solution, or try the match lighting procedure below.



CAUTION

THE WARMING RACK SHOULD ALWAYS BE REMOVED WHEN USING THE ROTISSERIE BURNER. FAILURE TO DO SO MAY RESULT IN A DAMAGED AND WARPED WARMING RACK.

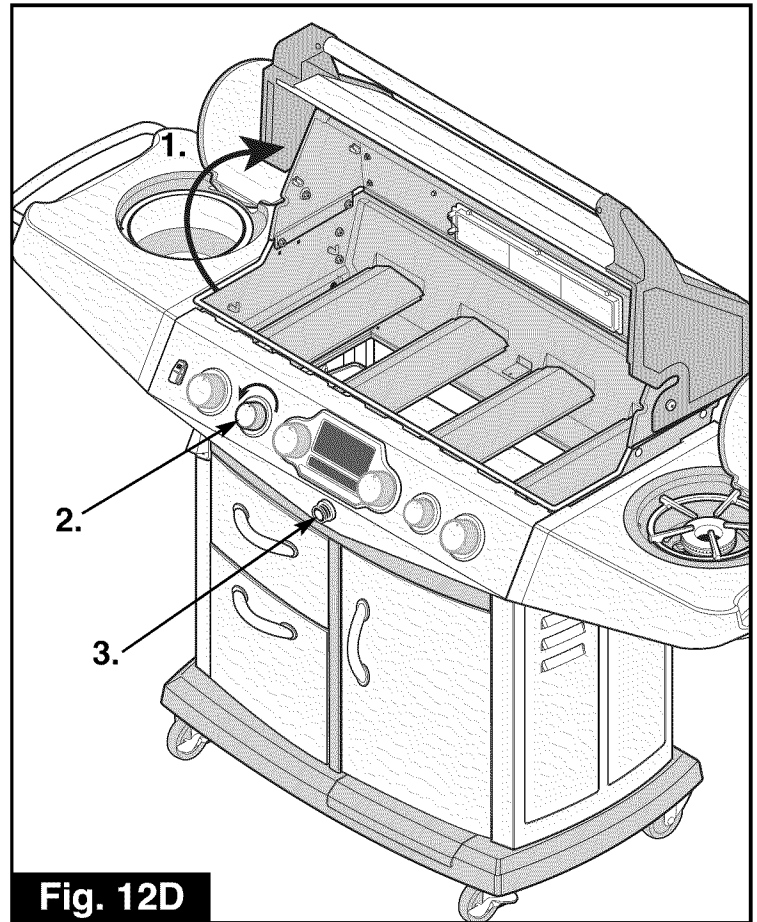

Fig. 12D

REAR ROTISSERIE BURNER MATCH LIGHTING PROCEDURE

1. OPEN LID PRIOR TO LIGHTING.
2. Place an ignited lighter or lit match near the ports, approximately 1/2" (1.25 cm) from burner (see Figure 12E).
3. Push in and turn the rotisserie burner control knob to 'HIGH'. The burner should light immediately (within five seconds). If it does not turn off the control knob, extinguish the lighter or match, and wait 5 minutes for gas to clear.
4. Repeat steps 1 to 4. If burner still fails to light, refer to the Troubleshooting Guide to determine the cause and solution.

NOTE: DO NOT USE THE MAIN BURNERS WHEN THE ROTISSERIE BURNER IS LIT.

Please also refer to additional rotisserie instructions that are supplied with your rotisserie kit.

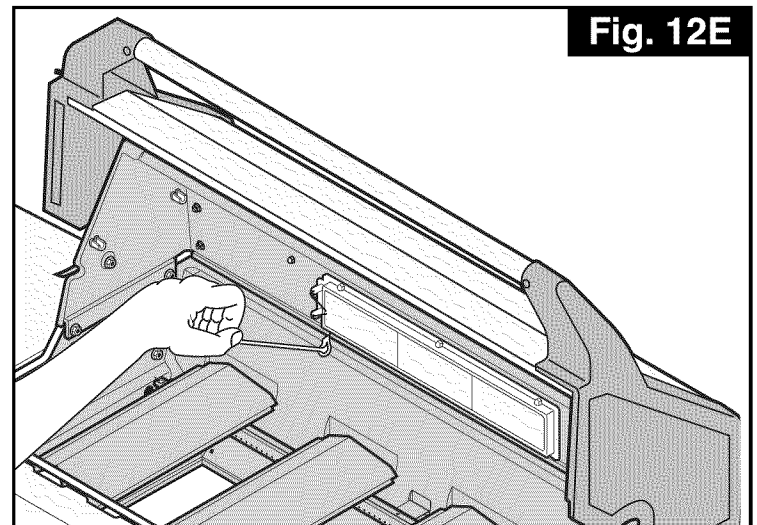

Fig. 12E

SHUTTING DOWN YOUR BARBEQUE

1. Shut off L.P. cylinder valve.
2. Shut off burner control valves.

This sequence prevents residual gas from being left in the system under pressure.

BREAKING IN YOUR BARBEQUE

Before cooking on your gas barbeque for the first time...

Before cooking on your gas barbeque for the first time, you should "break it in" by operating **THE MAIN BURNERS** for a short period of time without any food. To "break in" your barbeque light the barbeque following the lighting instructions as outlined on the console or in this manual. (see pages 10, 11 & 12)

BREAKING IN THE MAIN BURNERS:

Close the **MAIN CASTING LID ONLY** and keep the temperature on "HIGH" for 20 minutes. **DO NOT OPEN THE LID DURING THIS PROCESS.** Then raise the lid and continue to operate your barbeque on "HIGH" for an additional 5 minutes. Your barbeque is now ready for cooking.

NOTE:

"Break-in" procedure is not required for Side Burner or Rotisserie burner. For lighting instructions for the Side Burner follow the lighting instructions found on page 11 of this manual. For lighting instructions for the rotisserie follow the lighting instructions found on page 12 of this manual.

CAUTION: THE SIDE BURNER LID SHOULD ALWAYS BE OPEN WHILE SIDE BURNER IS LIT.

CAUTION: THE WARMING RACK SHOULD ALWAYS BE REMOVED WHEN USING THE ROTISSERIE BURNER. FAILURE TO DO SO MAY RESULT IN A DAMAGED AND WARPED WARMING RACK.

COOKING TECHNIQUES

PREHEATING THE BARBEQUE

The cooking system and grids require heating prior to adding food.

1. Light your barbeque as outlined in the 'LIGHTING' instruction section.
2. Once lit, preheat your barbeque on the HIGH setting with the lid down for 6 to 10 minutes.

NOTE: OPTIONAL SIDE BURNER DOES NOT REQUIRE TO BE PREHEATED. NEVER OPERATE SIDE BURNER WITH SIDE BURNER LID CLOSED.

3. Turn the burner control knobs to the appropriate heat setting prior to adding your food. Preheating your barbeque is not required when you are cooking food using indirect cooking techniques.

MAIN CASTING LID POSITION

Although keeping the main casting lid up or down when cooking on your barbeque is a personal preference, you will find that you will have fewer flare-ups, and your food will cook in less time (therefore using less fuel) if the main casting lid is down. Keep the main casting lid down when cooking food that requires a long cooking period over a low flame, such as indirect cooking.

COOKING TEMPERATURES

HIGH Setting: Use the HIGH setting to preheat the barbeque, sear meat such as steak, & to burn off any cooking residue from the grids after cooking your meal. HIGH is rarely used for extended cooking.

MEDIUM Setting: Most grilling or roasting of meat and vegetables, as well as any baking, is best done at a medium heat.

LOW Setting: A low temperature is used when cooking lean meat or delicate items such as fish. All smoke cooking is done at low heat. For the best results, invest in a Meat Thermometer

BARBEQUE COOKING METHODS

Your barbeque is more than just a place to grill your burgers and hotdogs - the possibilities are as endless as your imagination. But, before you start experimenting, here are some frequently used terms that will help:

Direct Cooking is also known as grilling. This is the most popular cooking method and involves cooking food directly over the flame, such as searing a steak. Other good candidates for this cooking method are thin cuts of meat, vegetables, kabobs and fillets.

Indirect Cooking means the food is cooked away from the direct flame by placing it on the opposite side of the lit burner & allowing the heat to tumble within the closed confines of the closed barbeque, very similar to a convection oven. Much like your oven, you can roast and even bake, provided your barbeque lid is closed.

WARMING RACKS

A warming rack may be included with your barbeque and provides you with additional cooking space away from direct heat. This is useful when cooking delicate items such as fish, boneless chicken breasts or vegetables. Warming racks are also a great place to keep food warm that is already done so you can serve your entire meal at the same time.

Tip: A light application of cooking oil prior to use will help to keep food from sticking to the warming rack.

CONTROLLING FLARE-UPS

Some flare-up during grilling is desirable to create the smoke, which gives barbequed food its unique flavor and appearance. However, excessive flare-up can not only ruin your food, it may lead to a dangerous condition as well. By excessively raising the temperature within your barbeque, particularly if a build up of grease in your barbeque ignites, these flare-ups may result in an uncontrolled grease fire.

TO MINIMIZE FLARE-UPS:

- Trim excess fat from meats before cooking
- Cook fatty meats on a low setting, or by using the indirect method as described above
- Ensure that your cooking system is free of excess grease from previous usage
- Check that the grease drain hole is not blocked
- Cook with lid down to cut down on the flow of air
- Reduce the heat settings

PROVIDING POWER TO YOUR BARBEQUE

To provide power to the barbecue, plug grounded electrical cord into rear electrical box as shown. (Fig.15)

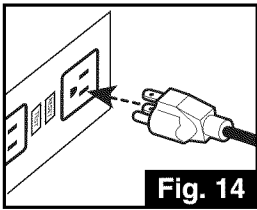

Fig. 14

Plug electrical cord into properly grounded GFI (Ground Fault Interrupt) receptacle. If use of an extension cord is required, be sure that it is a minimum 16 AWG, 3 wire well insulated cord, marked for OUTDOOR USE ONLY and properly grounded. (Figure14)

CAUTION: To ensure continued protection against risk of electric shock, connect to properly earthed outlets only.

INTERNAL LIGHT

The barbecue light allows you to cook even when it is dark. This light is pre-assembled and just requires to be plugged into the electrical box at the back. **Tip:** To ensure light remains clean, use a damp sponge to get rid of smoke residue before lighting grill.

ILLUMINATED SWITCH

The illuminated switch allows you to easily turn the light on and off. (Figure 16)

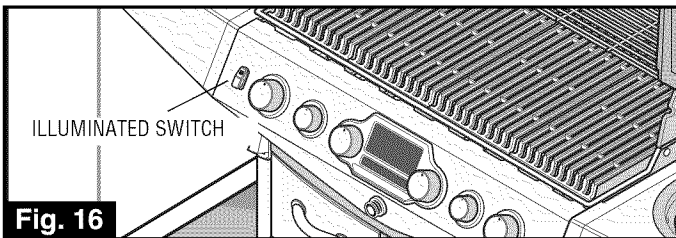

Fig. 16

ILLUMINATED SWITCH

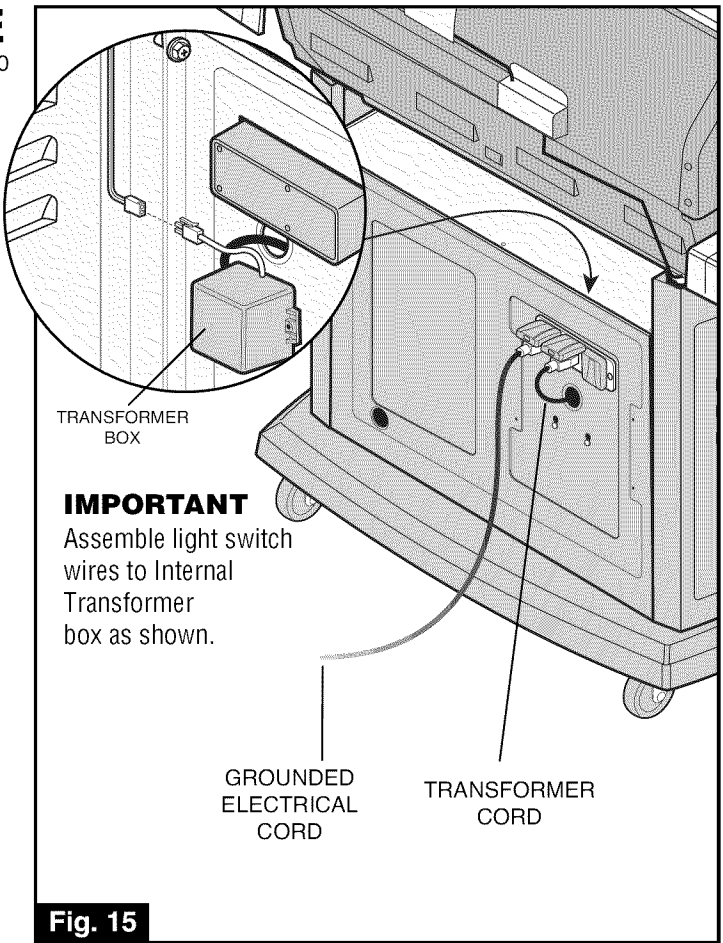

Fig. 15

TRANSFORMER BOX

IMPORTANT

Assemble light switch wires to Internal Transformer box as shown.

GROUNDING ELECTRICAL CORD

TRANSFORMER CORD

Important Safeguards

The following basic safety precautions apply when using electrical appliances:

- a) Read all instructions.
- b) Do not touch surfaces that may be hot. Use handles or knobs provided.
- c) To protect against electrical shock do not immerse cord, plugs, portable appliances (or other specific part or parts) in water or other liquid.
- d) Close supervision is necessary when any appliance is used by or near children.
- e) (i) Portable - Remove plug from outlet when the appliance is not in use, before putting on or taking off parts, and before cleaning. Allow to cool before handling.
(ii) Permanently installed - Make sure appliance is OFF when not in use, before putting on or taking off parts, and before cleaning.
- f) Portable - Do not operate any appliance with a damaged cord or plug or after the appliance malfunctions or is dropped or damaged in any manner. Return appliance to the nearest authorized service facility for examination, repair, or electrical or mechanical adjustment.
- g) The use of accessory attachments not recommended by the appliance manufacturer may cause injuries.
- h) Do not let cord hang over edge of table or counter or touch hot surfaces.
- i) Do not place on or near a hot gas or electric burner or in a heated oven.
- j) Extreme caution must be used when moving an appliance containing hot oil or other hot liquids.
- k) Where applicable, always attach plug to appliance and check that the control is OFF before plugging cord into wall outlet. To disconnect, turn the control to OFF, then remove plug from wall outlet.
- l) Do not use appliance for other than intended use.
- m) Avoid contacting moving parts.
- n) Save these instructions.
- o) Never remove the grounding plug or use with an adapter of 2 prongs; and
- p) Use only extension cords with a 3 prong grounding plug, rated for the power of the equipment, and approved for outdoor use with a W-A marking.
- q) When connecting, first connect plug to the outdoor cooking gas appliance then plug appliance into the outlet.
- r) Use only a Ground Fault Interrupter (GFI) protected circuit with this outdoor cooking gas appliance.

TROUBLE SHOOTING GUIDE

PROBLEM	POSSIBLE CAUSES	CORRECTION
Burner Will Not Light (match or ignitor) or Burners Not Hot Enough	<ul style="list-style-type: none"> Blocked venturi tubes Cylinder or gas supply valve turned off Venturi tubes not properly seated over valve orifices Burner ports blocked PROPANE BARBEQUES ONLY <ul style="list-style-type: none"> Low or out of propane Flow control device activated Regulator not fully tightened into cylinder 	<ul style="list-style-type: none"> Clean out blockage (Page 7) Open cylinder or gas supply valve Ensure proper venturi assembly (Page 3) Clean/replace burner (Page 8) Refill cylinder Follow correct lighting procedure (Page 10, 11, & 12) Perform leak test and correct leaks (Page 7) Tighten regulator fully (hand tight) into cylinder
ELECTRONIC IGNITION • No sparks appear at any electrodes when ignition button is pushed; no noise can be heard from spark module.	<ul style="list-style-type: none"> Battery not installed properly. Dead battery. Button assembly not installed properly. Faulty spark module. 	<ul style="list-style-type: none"> Check battery orientation. (Page 9) Has battery been used previously? Replace Battery. Check to insure threads are properly engaged. Button should travel up and down without binding. If no sparks are generated with new battery and good wire connections, module is faulty.
• No sparks appear at any electrodes when ignition switch is pushed; noise can be heard from spark module.	<ul style="list-style-type: none"> Output lead connections not connected. 	<ul style="list-style-type: none"> Are output connections on and tight? Remove and reconnect all output connections at module and electrodes.
• Sparks are present but not at all electrodes and/or not at full strength	<ul style="list-style-type: none"> Output lead connections not connected. Arcing to grill away from burner(s). Weak battery. Electrodes are wet. Electrodes cracked or broken "sparks at crack". 	<ul style="list-style-type: none"> Are output connections on and tight? Remove and reconnect all output connections at module and electrodes. If possible, observe grill in dark location. Operate ignition system and look for arcing between output wires and grill frame. If sparks are observed other than from burner(s), wire insulation may be damaged. Replace wires. All sparks present but weak or at slow rate. Replace battery with a new AA-size alkaline battery. Has moisture accumulated on electrode and/or in burner ports? Use paper towel to remove moisture. Inspect electrodes for cracks, if found, replace cracked or broken electrodes.
Flames Smokey Yellow	<ul style="list-style-type: none"> Partially blocked venturi tubes Excess cooking salts on burner Air shutter closed (side burner only) 	<ul style="list-style-type: none"> Clean out blockage (Page 7) Clean burner (Page 8) Open air shutter
Burner Lights With Match Not With Ignitor (no spark)	<ul style="list-style-type: none"> Loose wire connection Broken electrode ceramic Poor ground Faulty Ignitor 	<ul style="list-style-type: none"> Check all connections are tight Replace Ensure collector box, burner and ignitor are assembled properly.
Flame Blows Out/Down Through Base	<ul style="list-style-type: none"> High wind conditions PROPANE BARBEQUES ONLY <ul style="list-style-type: none"> Propane low 	<ul style="list-style-type: none"> Relocate barbeque back towards wind Refill cylinder
Too Much Heat/Excessive Flare-up Persistent Grease Fire	<ul style="list-style-type: none"> Excessive fat in meat Grease drain plugged Cooking system clogged with grease Cooking system not positioned correctly 	<ul style="list-style-type: none"> Trim meat/turn down burner controls and/or fuel supply Clean casting base and burner (Page 8) Clean smart bars, heat distribution plate (Page 8) Position cooking system correctly
Flames Under Heat Control Console	<ul style="list-style-type: none"> Blocked venturis 	<ul style="list-style-type: none"> Immediately shut off gas at source, allow grill to cool and clean out venturis (Page 7)
Regulator Humming	PROPANE BARBEQUES ONLY <ul style="list-style-type: none"> This is not a defect or a hazard. 	<ul style="list-style-type: none"> Temporary condition caused by high outside temperature and usually a full L.P. cylinder
Incomplete Flame	<ul style="list-style-type: none"> Plugged, rusted, or leaking burner 	<ul style="list-style-type: none"> Clean/replace burner (Page 8)
Flashback... (fire in burner tube(s)).	<ul style="list-style-type: none"> Burner and/or burner tubes are blocked. 	<ul style="list-style-type: none"> Turn knobs to OFF. Clean burner and/or burner tubes. See burner cleaning section of Use and Care.
Unable to fill LP cylinder.	<ul style="list-style-type: none"> Some dealers have older fill nozzles with worn threads. 	<ul style="list-style-type: none"> The worn nozzles don't have enough "bite" to engage the valve. Try a second LP dealer.
One burner does not light from other burner(s).	<ul style="list-style-type: none"> Grease buildup or food particles in end(s) of carryover tube(s). 	<ul style="list-style-type: none"> Clean carry-over tube(s) with wire brush.
Sudden drop in gas flow or low flame.	<ul style="list-style-type: none"> Out of gas. Excess flow valve tripped. Vapor lock at coupling nut/LP cylinder connection. 	<ul style="list-style-type: none"> Check for gas in LP cylinder. Turn off knobs, wait 30 seconds and light grill. If flames are still low, turn off knobs and LP cylinder valve. Disconnect regulator. Reconnect regulator and leak-test. Turn on LP cylinder valve, wait 30 seconds and then light grill. Turn off knobs and LP cylinder valve. Disconnect coupling nut from cylinder. Reconnect and retry.

LIMITED WARRANTY

1. LIMITED WARRANTY COVERAGE

5 YEAR LIMITED WARRANTY - STAINLESS STEEL BURNERS

1 YEAR LIMITED WARRANTY - ALL OTHER PARTS

Blue Ember gas barbeque owners have the benefit of a limited warranty from the date of purchase against any and all defects in materials and workmanship during the period of warranty coverage specified. This limited warranty is extended to the original customer/purchaser only and is not transferable.

Your Fiesta / Blue Ember barbeque (and related equipment) have been certified for use in by the applicable certifying authorities specified on the rating plate affixed to the barbeque and related equipment. **Your Fiesta / Blue Ember barbeque must be used only in accordance with the applicable certification and Fiesta / Blue Ember's Use and Care Instructions. It must be assembled in accordance with applicable Fiesta / Blue Ember assembly guide. Fiesta does not recommend the conversion of the gas supply specified on the rating plate to any other fuel or equipment.** Any conversion will result in the termination of the Fiesta Blue Ember warranty and the default of the applicable certification.

Date and proof of purchase is mandatory for all warranty claims. Always identify the product, model number and serial number when requesting warranty coverage.

This warranty covers replacement parts only. All other costs including labor, transportation postage and other incidental service costs are the responsibility of the applicant.

The use of non Fiesta / Blue Ember replacement parts automatically voids the Fiesta Barbeque Warranty

2. LIMITATIONS

This limited warranty applies only to Blue Ember barbeques that have been properly assembled, operated and maintained and reasonably used as defined in the Blue Ember care and use manual, and assembly instructions. Please refer to the care and use section of this manual for instructions on the proper care and use of your Blue Ember barbeque.

YOUR BLUE EMBER PRODUCT MUST BE USED ONLY IN ACCORDANCE WITH APPLICABLE CERTIFICATION AND FIESTA'S USE AND CARE INSTRUCTIONS

Fiesta shall not be responsible for any indirect or consequential damages arising as a result of any defect in the barbeque whether such defect is covered by warranty or not. This limited warranty does not apply to and IN CANADA - Fiesta Barbeques A Division of Wolfedale Engineering Ltd. or in USA - Fiesta Gas Grills , LLC. shall not be responsible or liable for any failures or operating difficulties caused by anything other than defective materials or workmanship.

There are no other warranties or conditions, express or implied, statutory or otherwise (including any implied warranty of merchantability or fitness for a particular purpose) except as expressly provided for herein. No person is authorized to create for Fiesta / Blue Ember any condition or liability in connection with the barbeque.

Exclusions to this warranty include: 1. Normal wear and tear 2. Accidental damage 3. Abuse 4. Tampering or misuse 5. Alteration 6. Misapplication 7. Vandalism 8. Careless handling 9. Improper Installation 10. Improper assembly 11. Improper use, maintenance or service 12. Deterioration or damage due to severe weather i.e. hail, hurricanes, earthquake, tornados 13. Surface rust, or discoloration of stainless steel 14. Discoloration or paint chipping surface rust or rust perforation due to paint chipping resulting from normal wear and tear or causes other than defective material or due to chemical exposure in the atmosphere 15. Commercial or rental use 16. Use of improper or uncertified fuel, fuel source or equipment 17. Failure to do normal & routine maintenance or service, including (not limited to) removal of insects within the venturi tubes. The provisions of this additional written warranty are in addition to and not a modification of , nor subtraction from any other statutory warranties or other rights and remedies provided by any provincial law. Warranty will NOT apply if this gas grill is used for commercial or rental purposes.

MANUFACTURE WILL NOT REIMBURSE FOR:

Service calls to your residence.
Any food loss due to product failures.
Replacement part or repair labor costs for units operated outside the United States, Canada or Mexico.
The removal and/or reinstallation of your product.

The provisions of this additional written warranty are in addition to and not a modification of, nor subtraction from any other statutory warranties or other rights and remedies provided by any provincial law. The purchaser may have different rights which may vary from province to province in Canada and state to state in the United States of America according to applicable legislation. This warranty does not exclude or limit those statutory rights except to the extent permissible in law.

3. CONDITIONS FOR APPLICATION OF THE LIMITED WARRANTY

Purchaser must notify IN CANADA - Fiesta Barbeques A Division of Wolfedale Engineering Ltd. or in USA - Fiesta Gas Grills , LLC. immediately upon discovery of any defects in the barbeque or any parts thereof for which h purchaser claims coverage under this limited warranty. All warranty service and/or replacement of Blue Ember parts must be performed by the customer service department of IN CANADA - Fiesta Barbeques A Division of Wolfedale Engineering Ltd. or in USA - Fiesta Gas Grills , LLC. Customers seeking warranty service and/or replacement should contact Fiesta customer service with their model number, serial number and the nature of their claim. A tracking number will be issued at that time. All defective parts must be returned to Fiesta's customer service department, accompanied by the tracking number. The purchaser shall be responsible for performance and cost of disassembly, packaging and shipping costs. Fiesta will repair or (at it option) replace the defective components if after inspection it is evident that the defect occurred under normal domestic use.

All warranty replacement shall be subject to the terms and conditions of this warranty for the remainder of the original period of coverage.

4. REPLACEMENT

Fiesta / Blue Ember's undertaking under this limited warranty is:

For the first five years for stainless burners, or one years for all other parts from the date of purchase to replace the defective part or parts.

When replacement parts are provided, purchaser will be charged manufacturer's approximate cost of shipping and handling replacement parts. Re-assembly will be purchaser's responsibility.

To obtain replacement parts contact:	In Canada Fiesta Barbeques A Division of Wolfedale Engineering Ltd. 2 Walker Drive, Brampton Ontario L6T 5E1 Canada	In USA Fiesta Gas Grills , LLC. One Fiesta Drive Dickson, TN. USA 37033
--------------------------------------	--	--

PRE-ASSEMBLED BARBEQUE ASSEMBLY 1 OF 2

If you purchased your barbeque pre-assembled, please refer to this page for caster & tank caddy assembly. The assembly instructions for the door and shelves are located on page 18. Otherwise please proceed to page 19 for full assembly procedures.

TOOLS REQUIRED:

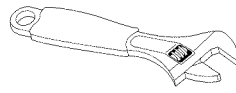

• Adjustable wrench

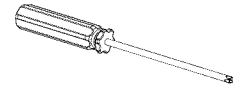

• #2 Phillips screwdriver

CASTER ASSEMBLY

STEP 1

Install the front casters using 2 people. One to tilt the barbeque back to allow the second person to place the ice/wine bucket supplied with your barbeque upside down under the front edge of the base pan for support. The front casters are then installed using a wrench as shown.

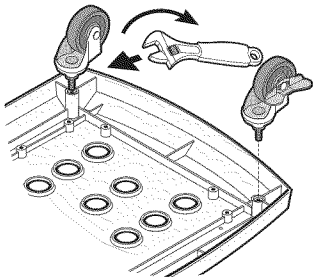

CAUTION:

DO NOT TILT BARBEQUE TOO FAR, AS PERSONAL INJURY MAY OCCUR.

STEP 2

Lock the front casters. Install the rear casters using 2 people. One to tilt the barbeque backward to allow the second person to place the ice/wine bucket supplied with your barbeque upside down under the rear edge of the base pan for support. The rear casters are then installed using a wrench as shown.

NOTE:

When tilting the barbeque forward place one foot in front of the base pan to help keep the bottom from moving.

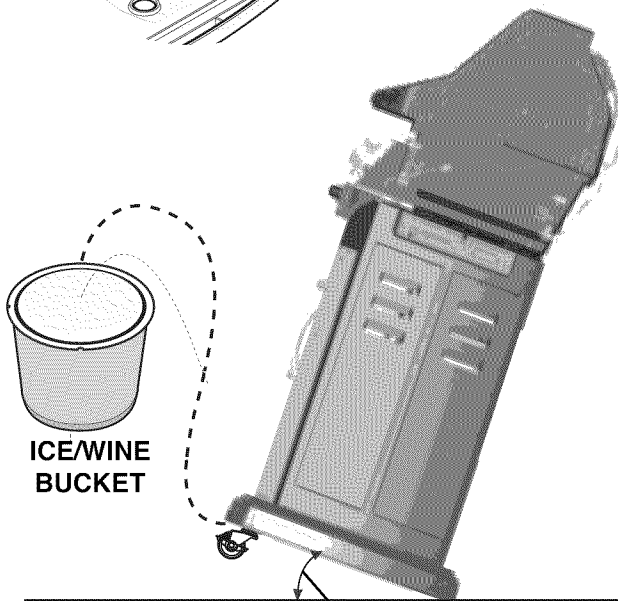

STEP 1

Lock front casters and place one foot in front of base to steady barbeque when tilting.

APPROXIMATELY 15 deg. angle

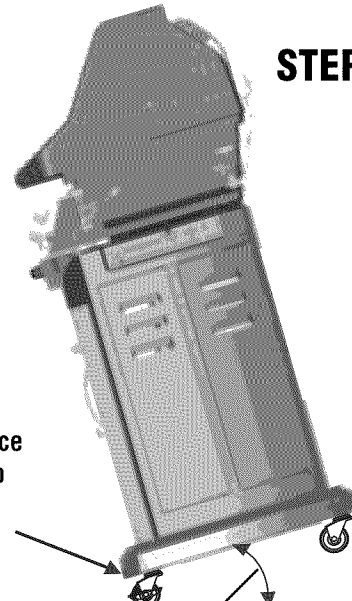

STEP 2

APPROXIMATELY 15 deg. angle

TANK CADDY ASSEMBLY

Please refer to FIG. 2 page 19 & FIG. 12 page 29 in this manual to assemble the Tank Caddy on this barbeque.

IMPORTANT:

Please read all assembly pages for important warnings, providing power, and tank assembly instructions.

PRE-ASSEMBLED BARBEQUE ASSEMBLY 2 OF 2

If you purchased your barbeque pre-assembled, please refer to page 17 for caster and tank caddy assembly. The assembly instructions for the door and self are located on this page. Other wise please proceed to page 19 for full assembly procedures.

DOOR ASSEMBLY

Please refer to FIG. 9 page 26 in this manual to assemble the Door on this barbeque.

SHELF & SIDE BURNER ASSEMBLY

- Attach towel bars to side self & side burner shelf as shown using #10 x .75" Hex Flange HD SELF TAP AB SCREWS.
- Please refer to FIG. 14 page 31 & FIG. 15 page 32 in this manual to assemble the side shelf & side burner assemblies.

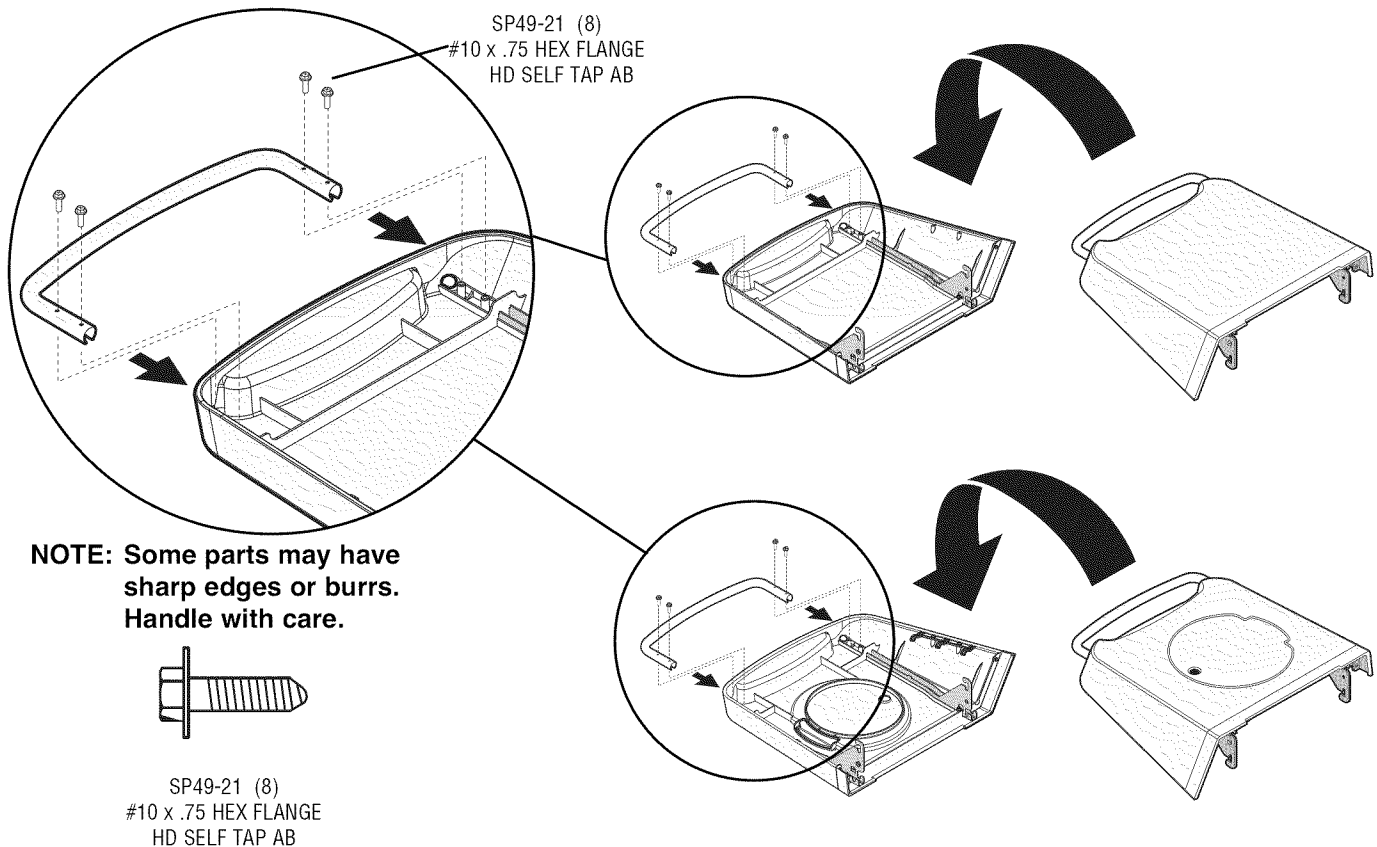

GREASE TRAP ASSEMBLY

Please refer to FIG. 16 page 33 in this manual to assemble the Grease Trap on this barbeque.

IMPORTANT:

PLEASE READ ALL ASSEMBLY PAGES FOR IMPORTANT WARNINGS, PROVIDING POWER, AND TANK ASSEMBLY INSTRUCTIONS.

CASTERS ASSEMBLY

FIG.1

NOTE:

Some grill parts shown in the assembly steps may differ slightly in appearance from those on your particular grill model. However, the method of assembly remains the same.

TOOLS REQUIRED:

- Extra Common Nuts & Bolts are supplied.
- Refer to diagrams to assemble your grill.



- Attach casters to bottom of base as shown.

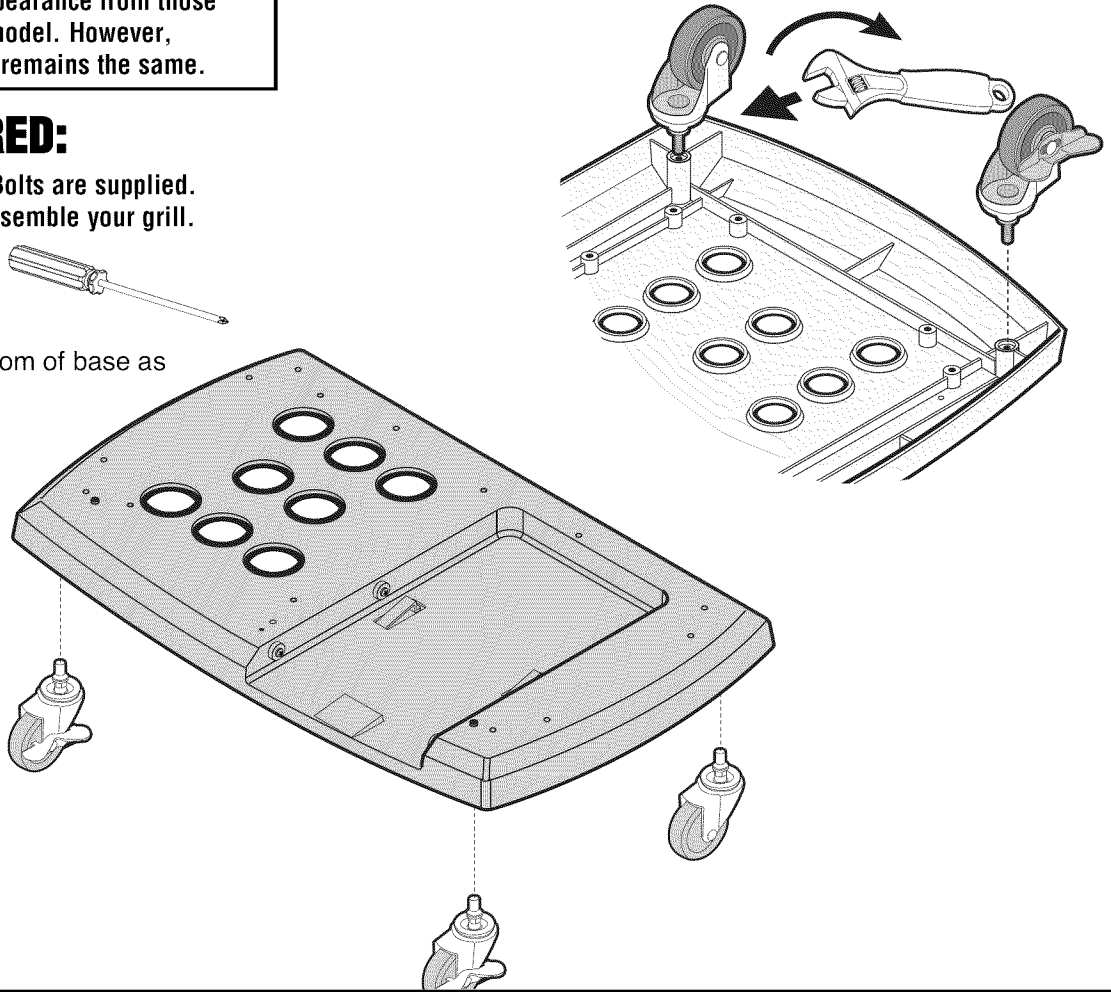

TANK CADDY ASSEMBLY

FIG.2

- Insert Tank Caddy as shown

CAUTION

PLEASE USE CAUTION WHEN ASSEMBLING THE TANK CADDY TO AVOID DAMAGE TO THE TANK SENSOR.

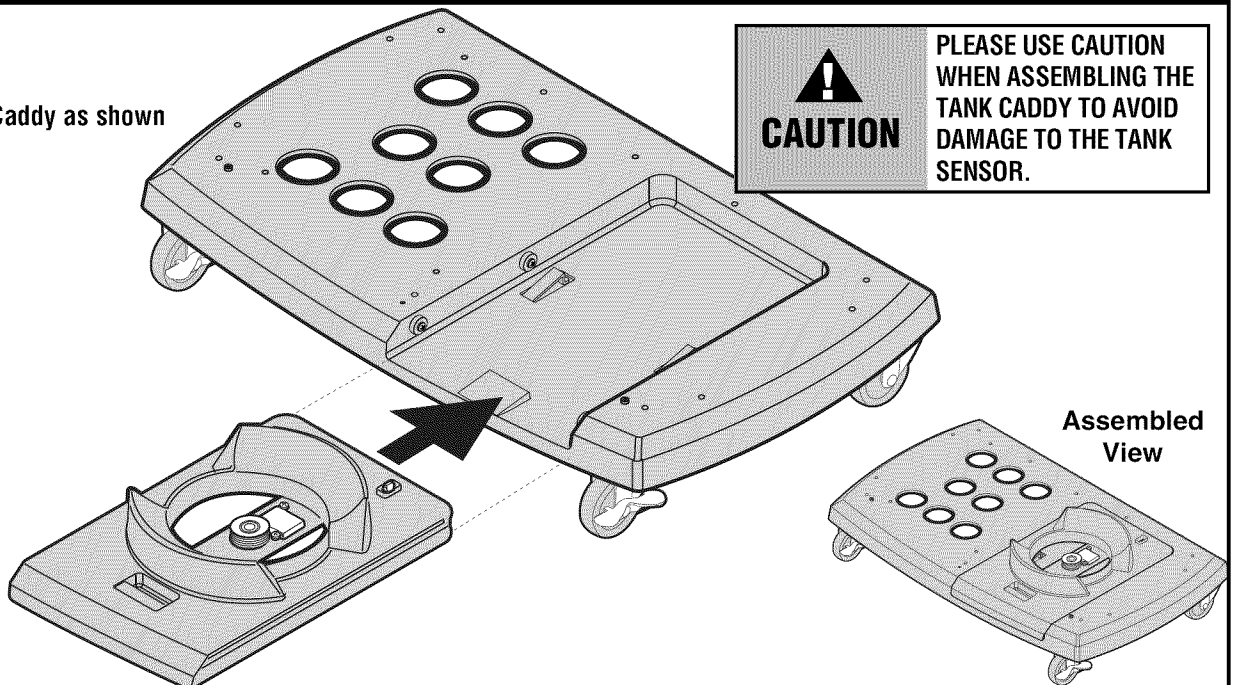

BASE CABINET ASSEMBLY

- Attach Cabinet side panels to base as shown.
- Attach bottle opener to left panel as shown.

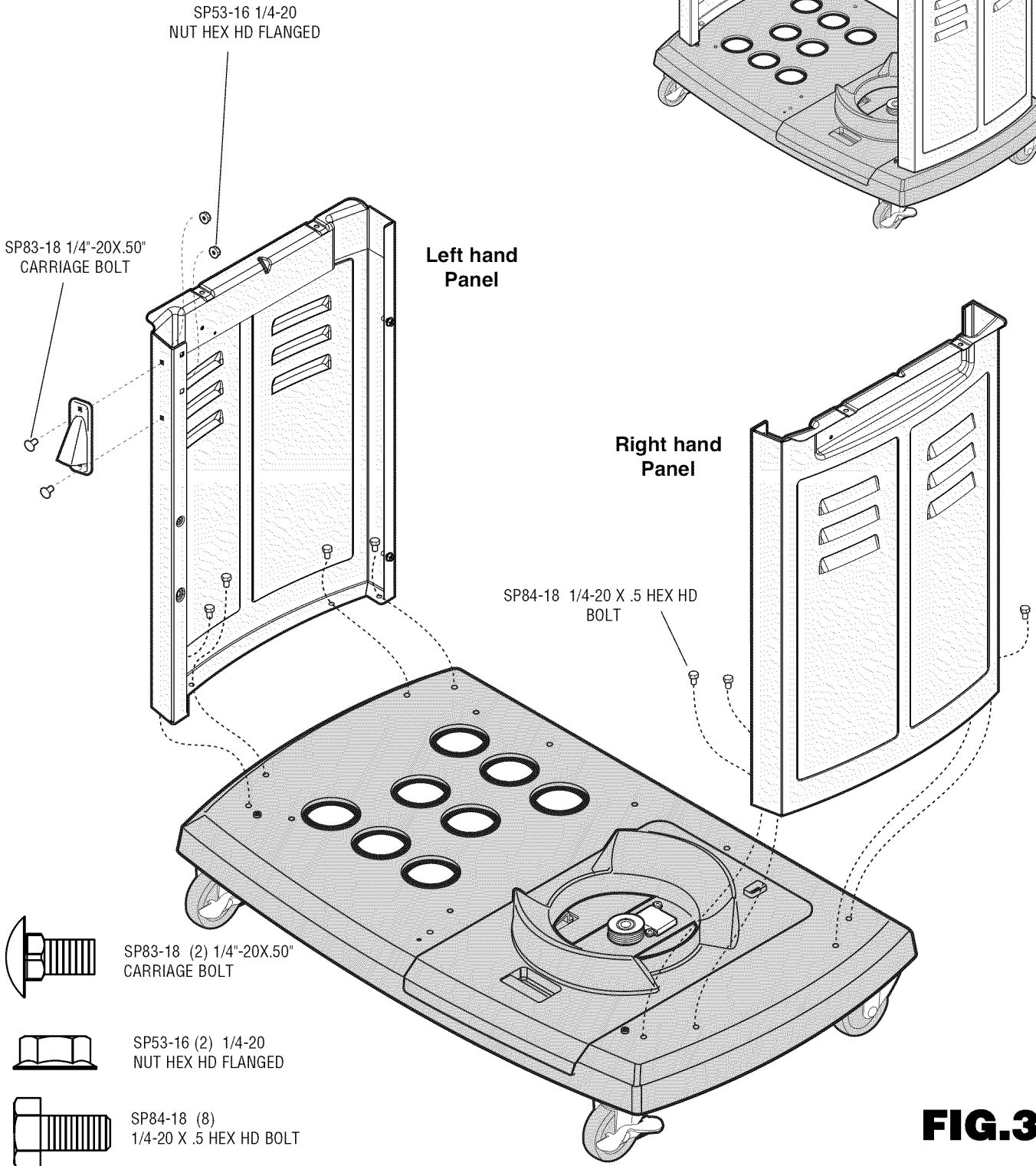
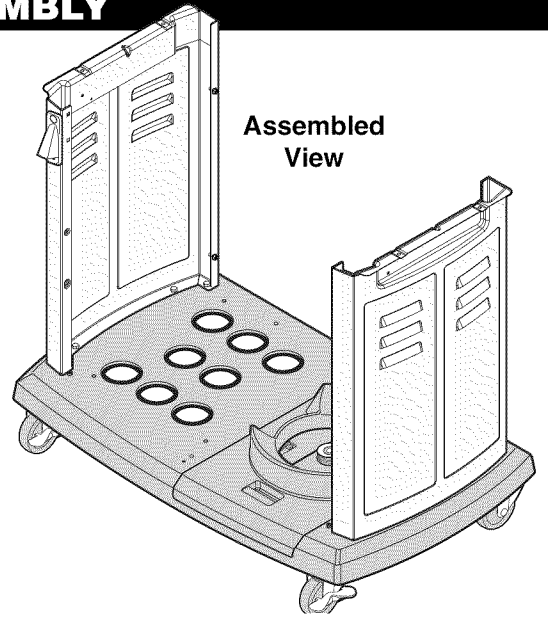
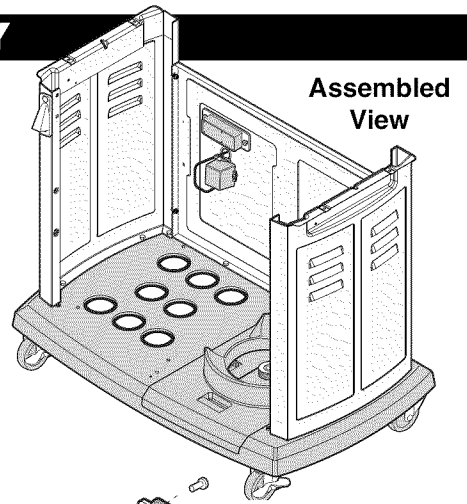

FIG.3

REAR PANEL ASSEMBLY

- Attach rear panel by sliding notches over screws on side panels as shown. Tighten screws.
- Install Electrical box with Screws and Nuts as shown. Ensure Electrical box is installed so outlet covers open upwards.
- Install Transformer box into rear panel holes as shown.



INSTALL SO OUTLET
COVERS OPEN
UPWARDS

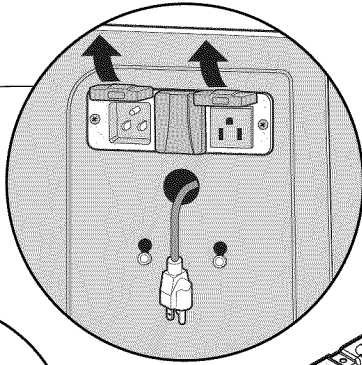

SP43-16 #10-24
NUT

SP83-21 #10-24
SCREW

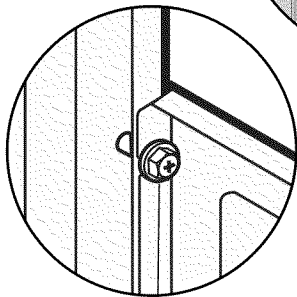

SP46-21 1/4" X 1/2"
SCREW HEX HD
SELF TAP B

SP84-18 1/4-20 X .5
HEX HD BOLT

TRANSFORMER
BOX

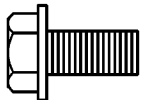
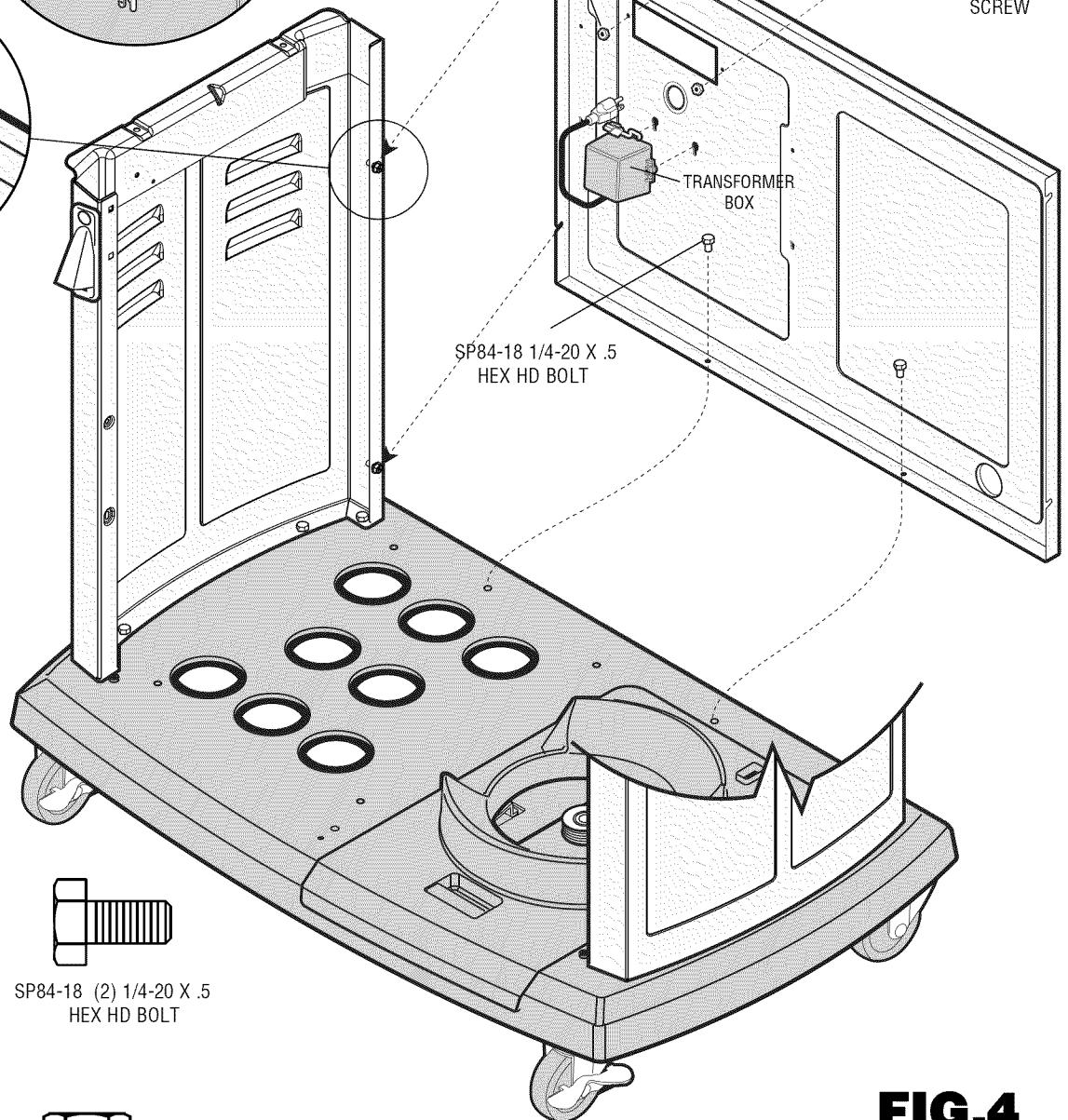

SP46-21 (4) 1/4" X 1/2"
SCREW HEX HD
SELF TAP B

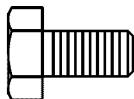

SP84-18 (2) 1/4-20 X .5
HEX HD BOLT

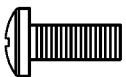

SP83-21 #10-24
SCREW (2)



SP43-16 #10-24 NUT (2)

FIG.4

TRIM PANEL AND CENTER SUPPORT ASSEMBLY

- Attach top trim panel as shown. Tighten screws.
- Attach center support as shown. Tighten screws.

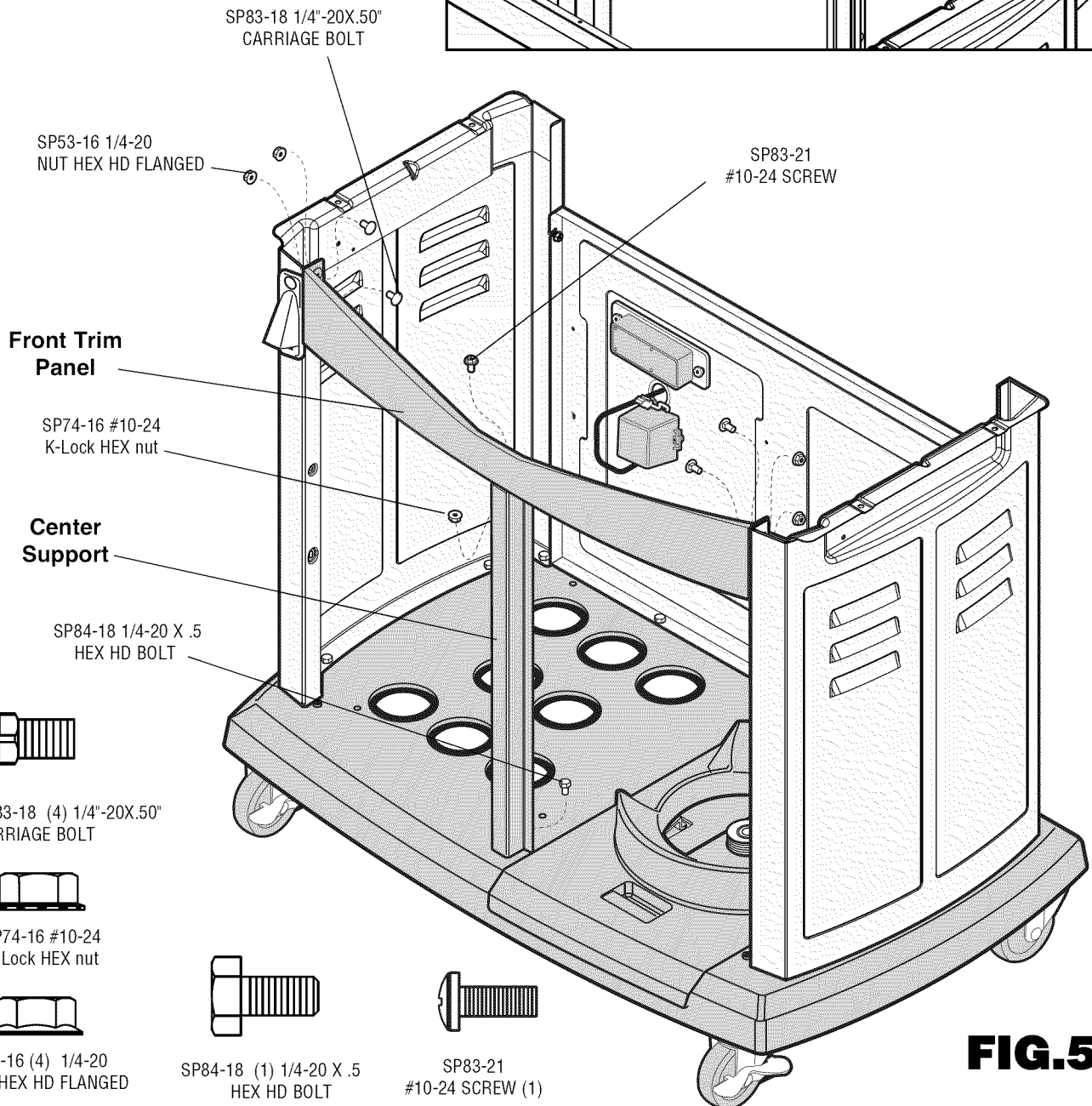
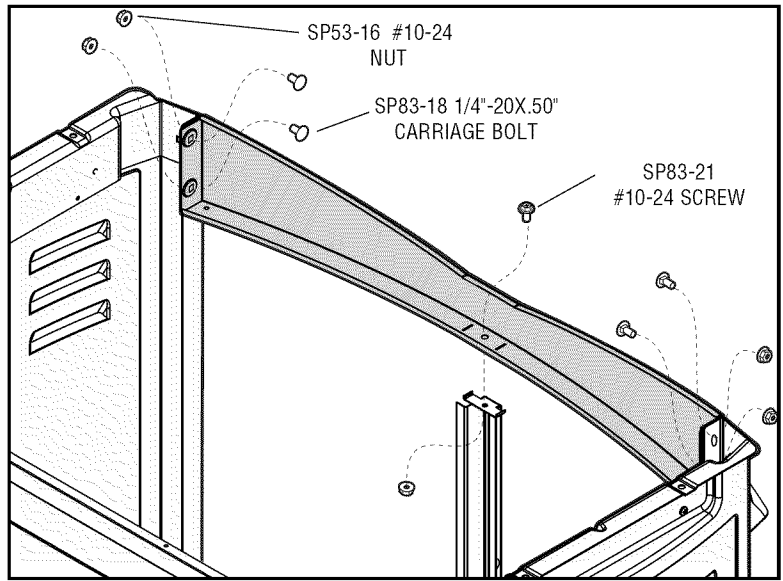
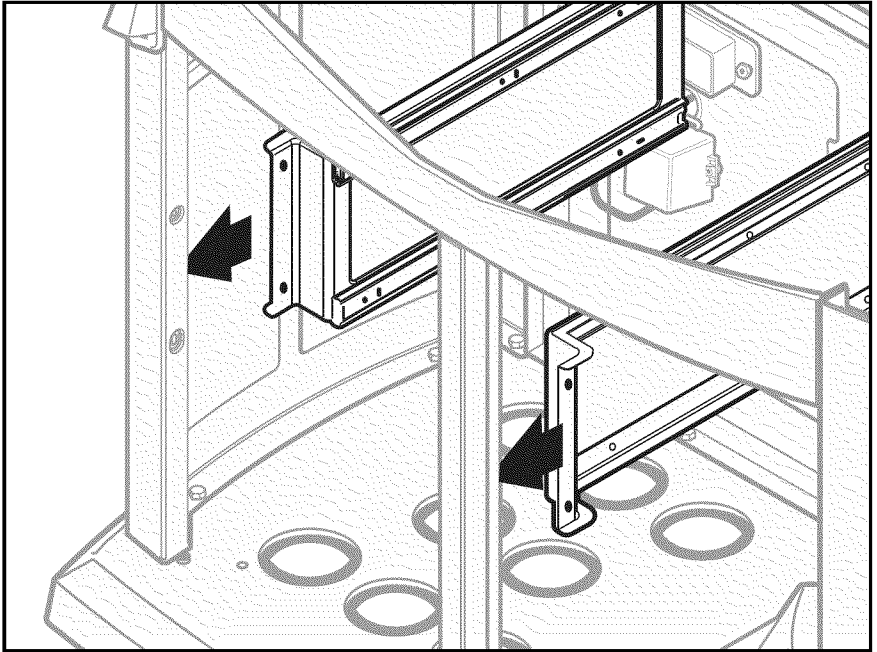

FIG.5

DRAWER RAIL BRACKETS ASSEMBLY

- Attach left and right drawer rail brackets as shown. Tighten screws.



Shelf Side Panels

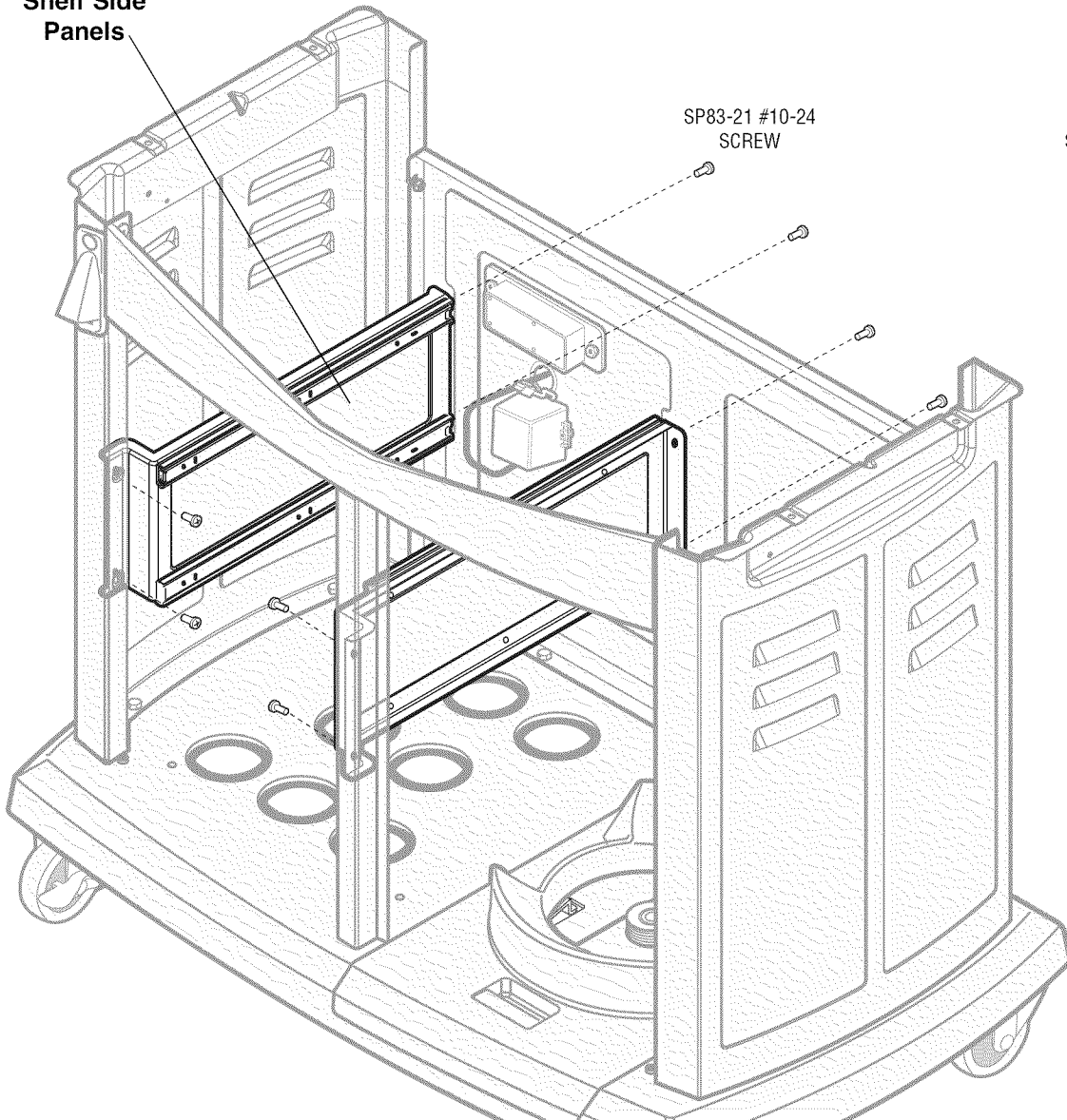

SP83-21 #10-24
SCREW

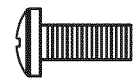

SP83-21 #10-24
SCREW (8)

FIG.6

DRAWER ASSEMBLY

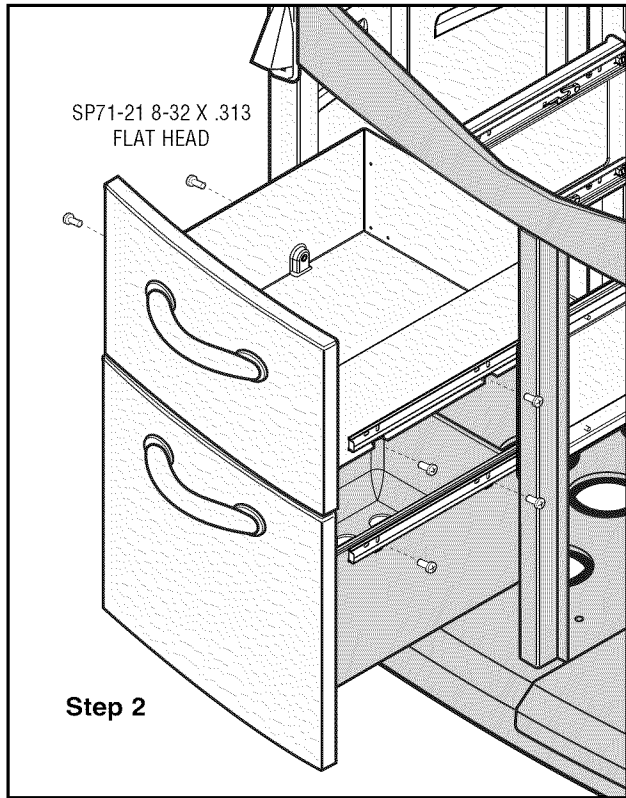

Step 1
Install drawer handles as shown

Step 2
Attach drawers to drawer slides as shown,
tighten screws.



SP41-16 #10-24
FLANGED HEX NUT (4)



SP71-21 8-32 X .313
FLAT HEAD (8)

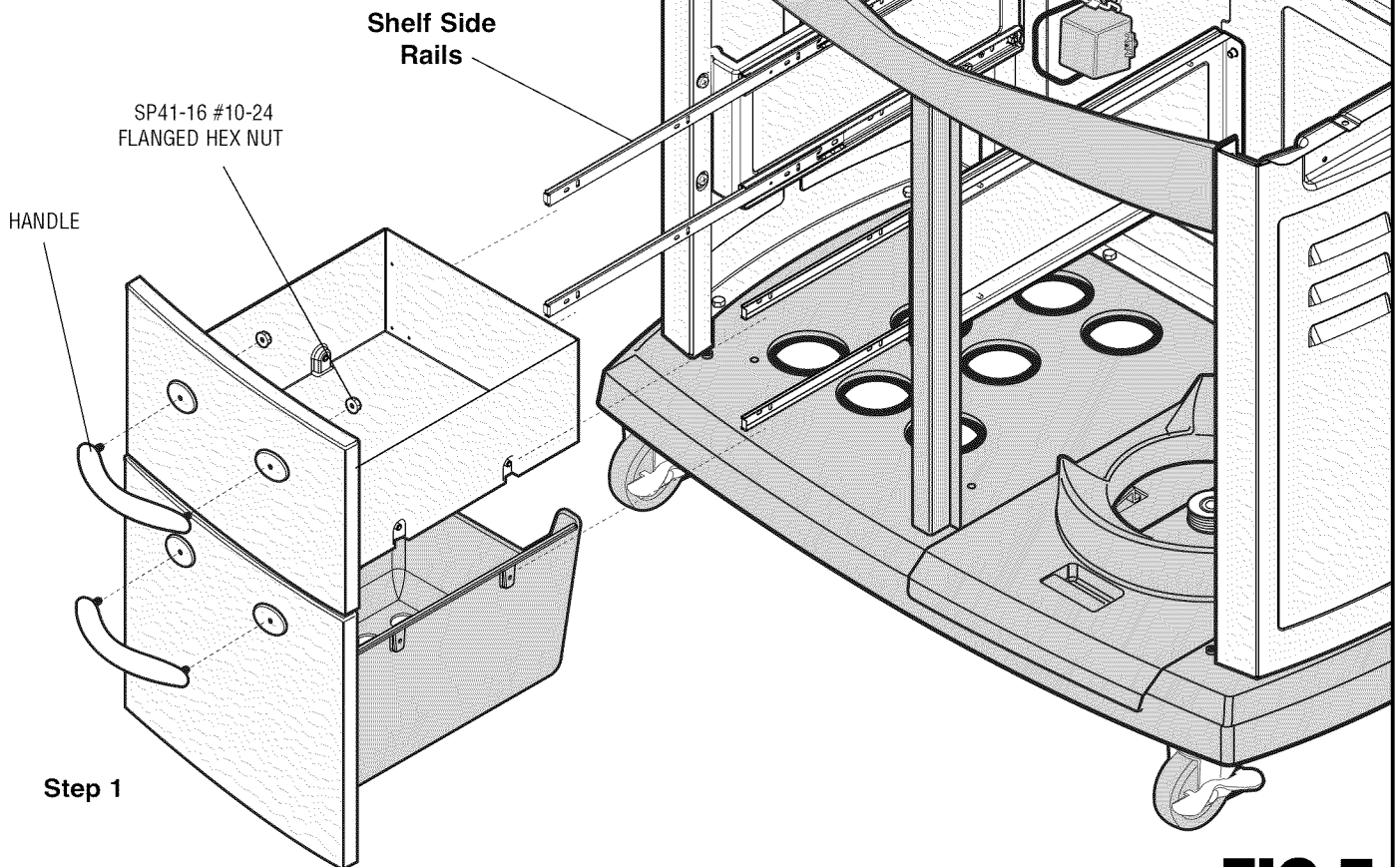
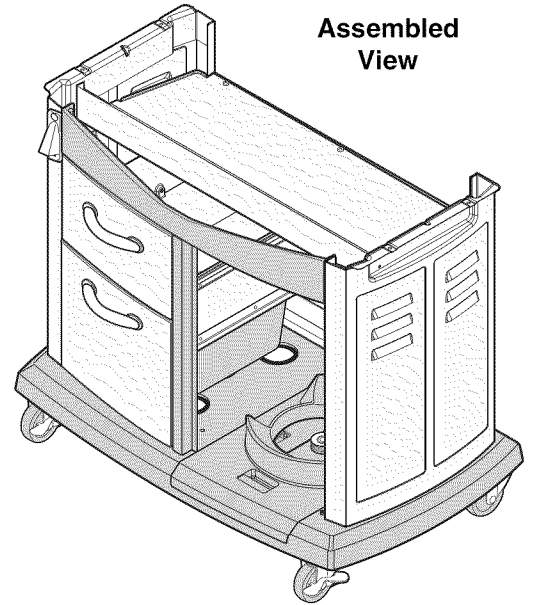

FIG.7

LOWER HEAT SHIELD ASSEMBLY

- Attach lower heat shield as shown. Tighten screws.

Assembled View



Heat Shield

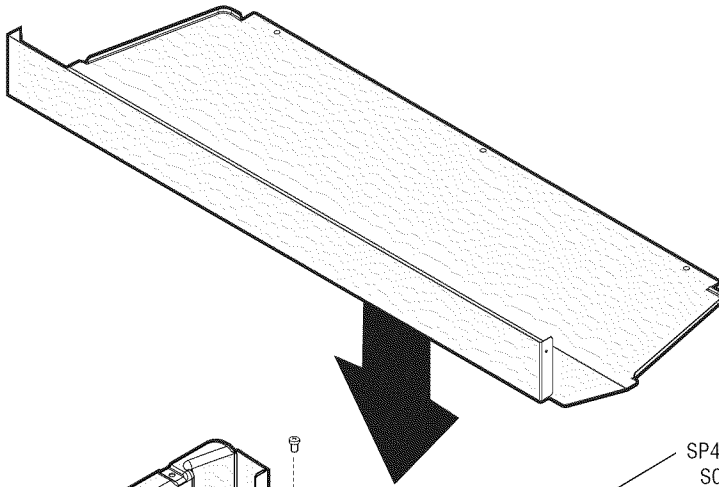

SP43-21 10-B X .375
SCREW SELF TAP

SP43-21 10-B X .375
SCREW SELF TAP (5)

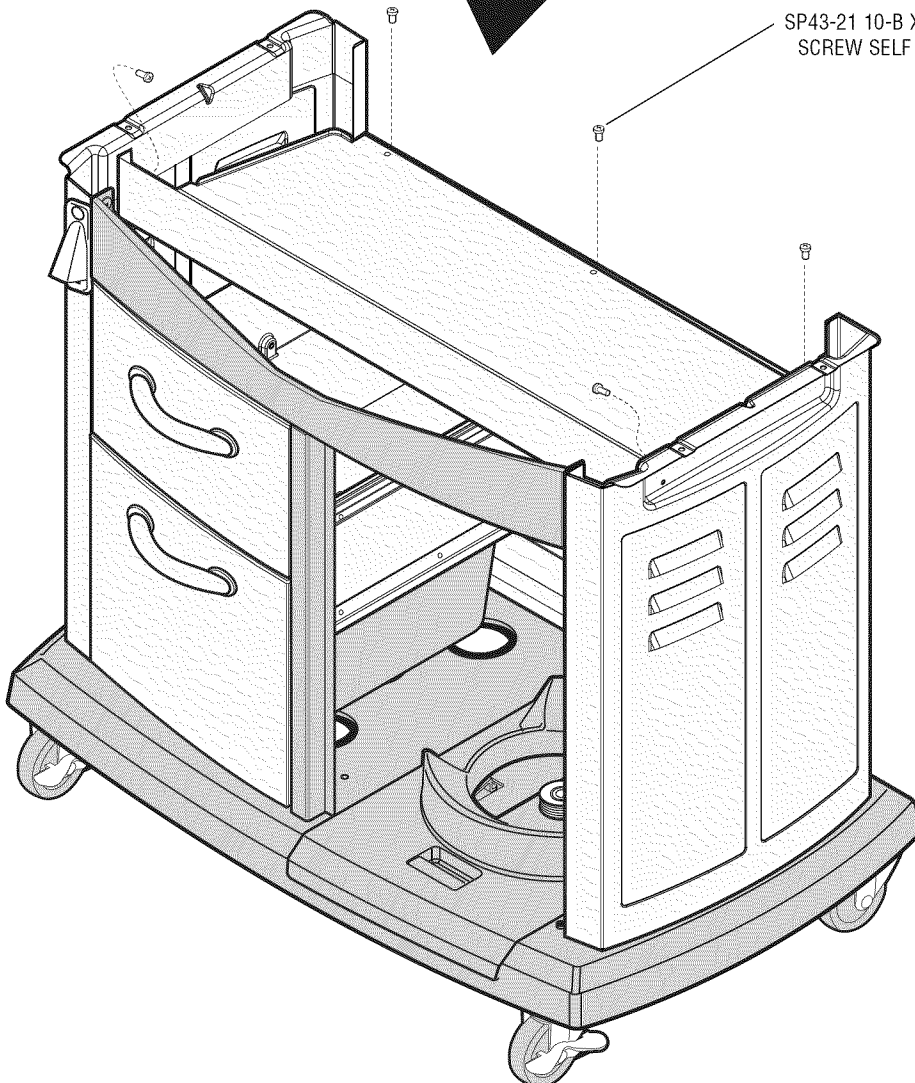
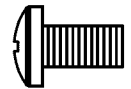

FIG.8

DOOR ASSEMBLY

- Install door handles as shown.
- Slide top pins on doors into upper holes as shown.
- A) Drop locking pins through lower holes in door into base assembly.
- B) Once in position rotate pins into locked position as shown.

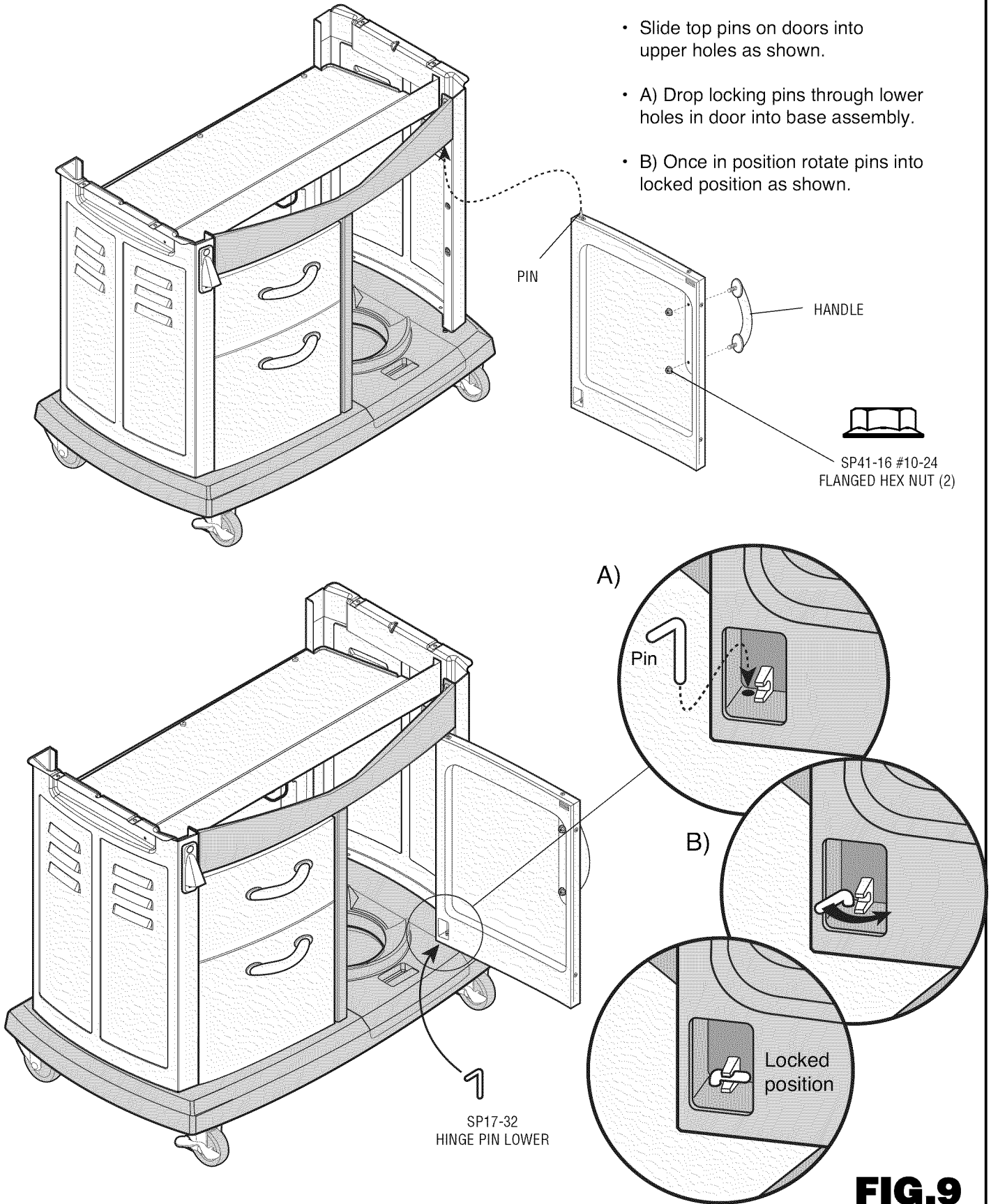

FIG.9

CASTING ASSEMBLY



WARNING

REGARDING IMPROPER ASSEMBLY OF HOSE ON PROPANE AND NATURAL GAS FG/FGQ650 MODELS

DURING THE ASSEMBLY PROCESS OF THE BASE ASSEMBLY STEP, THE CUSTOMER NEEDS TO ENSURE THAT THE HOSE IS UNTIED FROM BURNER BEFORE FINAL ASSEMBLY. CUSTOMER SHOULD RELEASE THE TIE AND PASS THE HOSE THROUGH THE GAP BETWEEN HEAT SHIELD AND FRONT PANEL BEFORE ASSEMBLING THE FIREBOX (BASE) TO THE CART (CABINET). NATURAL GAS (NG) HOSE MUST PASS THROUGH THE GAP AND THAT IS DIRECTED TO THE BOTTOM OF CABINET. PROPANE HOSE/REGULATOR SHOULD ALSO DIRECTED THROUGH THE GAP TO THE CYLINDER UNDERNEATH THE HEAT SHIELD.

FIG.10

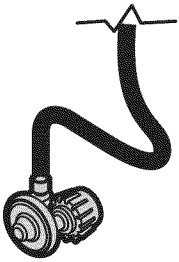

PROPANE
HOSE WITH
REGULATOR

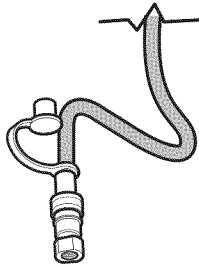

NATURAL GAS (NG)
HOSE WITH
ADAPTOR

Your barbeque will come equipped with one or the other, a propane hose with regulator, or NG hose with adaptor as shown. Hose type depends on model purchased.

**NOTE: THIS BARBEQUE IS NOT DUAL FUEL,
THE GAS TYPE AND HOSE ASSEMBLY
DEPENDS ON THE MODEL PURCHASED.**



IMPORTANT

**IF HOSE IS TIED TO BURNER OR
BASE, FIRST REMOVE THE
TIE AND PACKAGING AND THEN
ASSEMBLE THE GRILL TO BASE
AS SHOWN**

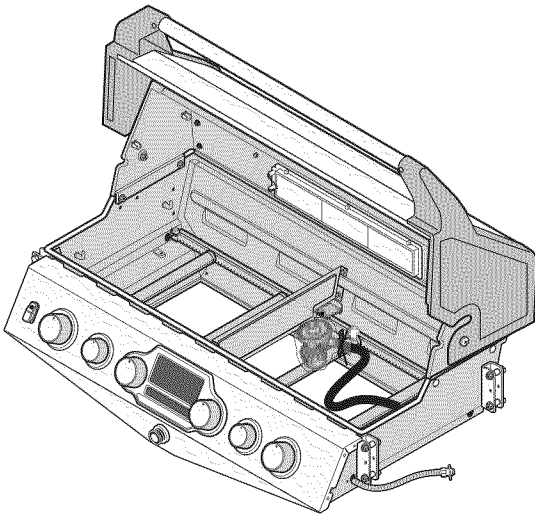

PROPANE MODEL

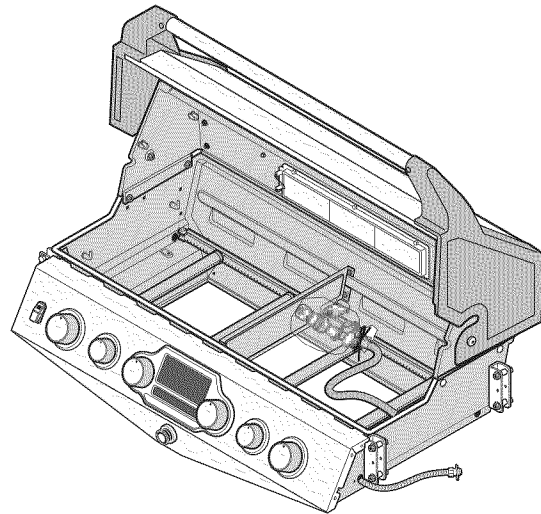

NG MODEL

CASTING ASSEMBLY

FIG.11



DANGER: DO NOT PASS HOSE ABOVE SHIELD HOSE MUST NOT TOUCH ANY PART OF THE BASE
WARNING:
ENSURE HOSE ASSEMBLY DOES NOT CONTACT THE CASTING, OR ANY OTHER PARTS WHICH WILL GET HOT.

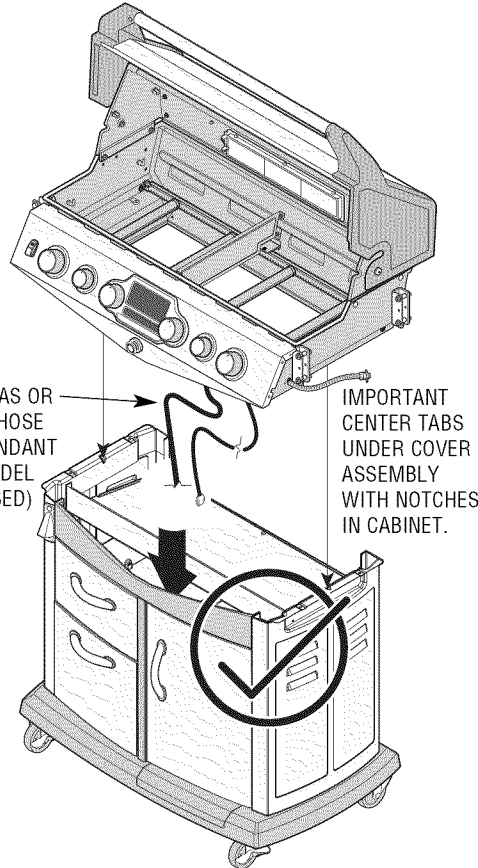
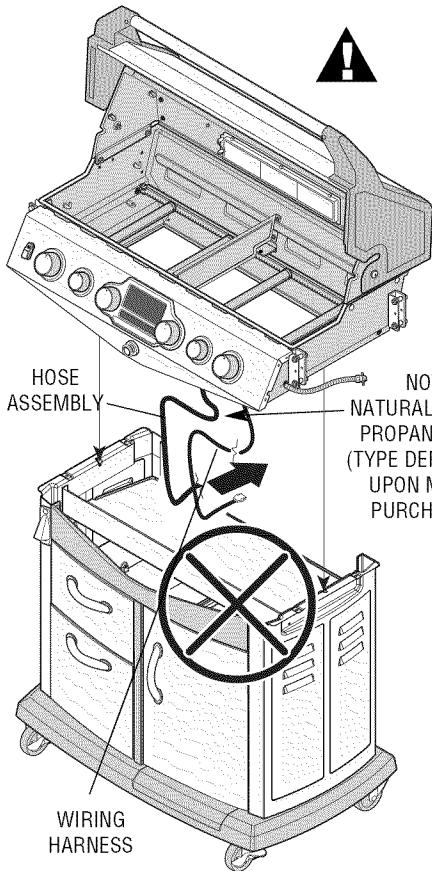

SP53-16 (4) 1/4-20
NUT HEX HD FLANGED

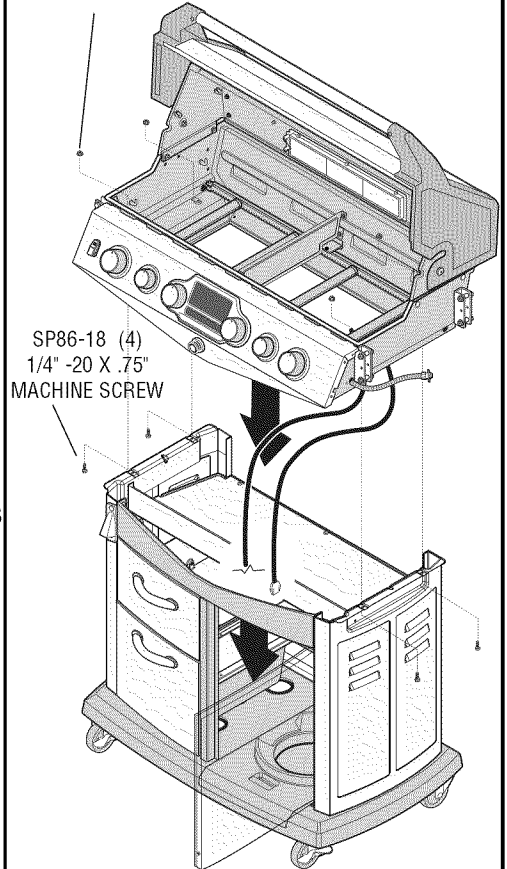

DO NOT PASS HOSE BEHIND THE HEAT SHIELD



DIRECT THE HOSE AND HARNESS TO THE FRONT OF THE HEAT SHIELD AS SHOWN



DIRECT THE HOSE AND HARNESS TO THE FRONT OF THE HEAT SHIELD AS SHOWN



FAILURE TO ENSURE THE ABOVE MAY RESULT IN HAZARDOUS FIRE OR EXPLOSION CAUSING SERIOUS BODILY INJURY AND/OR PROPERTY DAMAGE AND INVALIDATES WARRANTY

- Using two people, lower the top cover assembly carefully onto base and attach as shown.
- Push wiring harness and hose assembly through front of cart assembly ensuring it goes between heat shield and front panel opening.

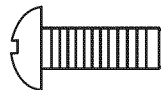

SP86-18 (4) 1/4" -20 X .75" MACHINE SCREW



SP53-16 (4) 1/4-20 NUT HEX HD FLANGED

FIG.12

- Secure base casting as shown.
- Plug wiring harness with jack into tank sensor connector found at back of tank caddy

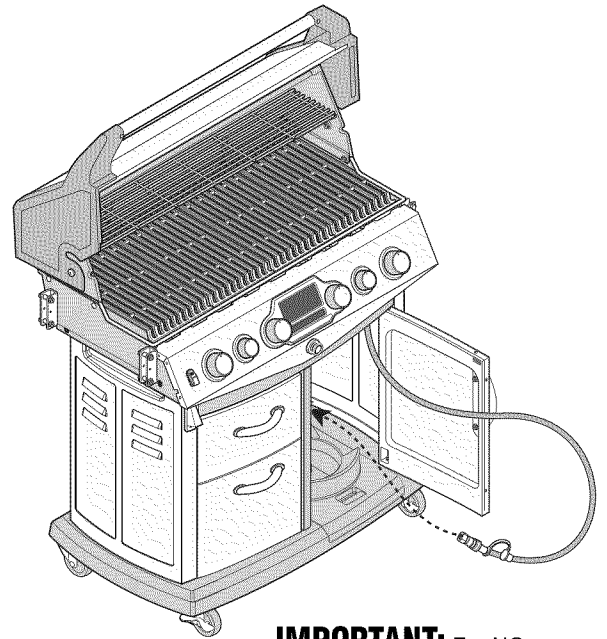
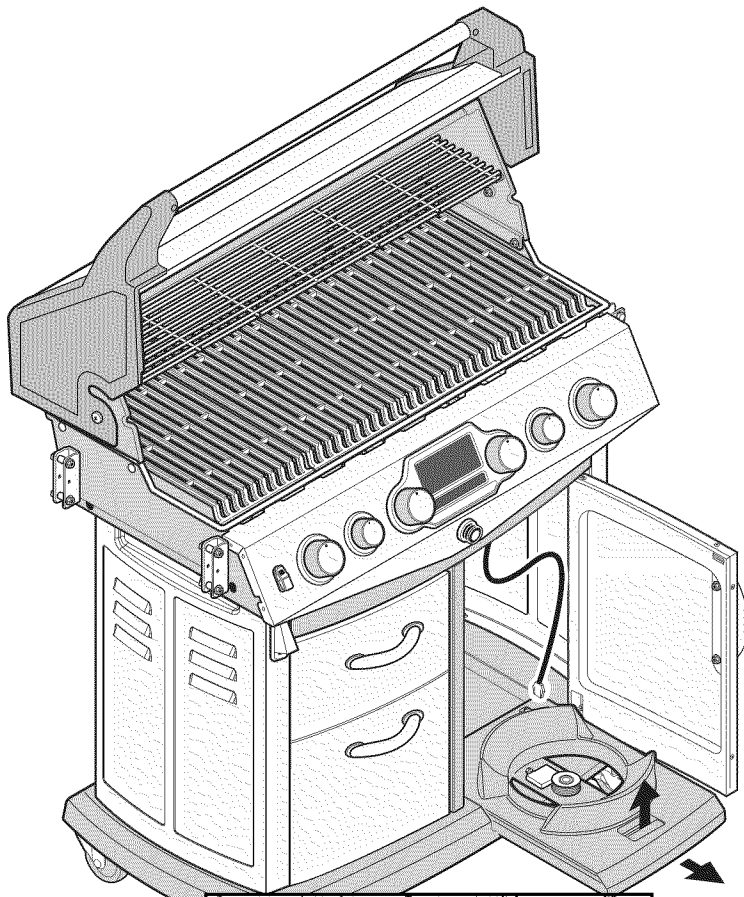

IMPORTANT: For NG models, direct the hose through the hole in the base as shown.

Assembled View

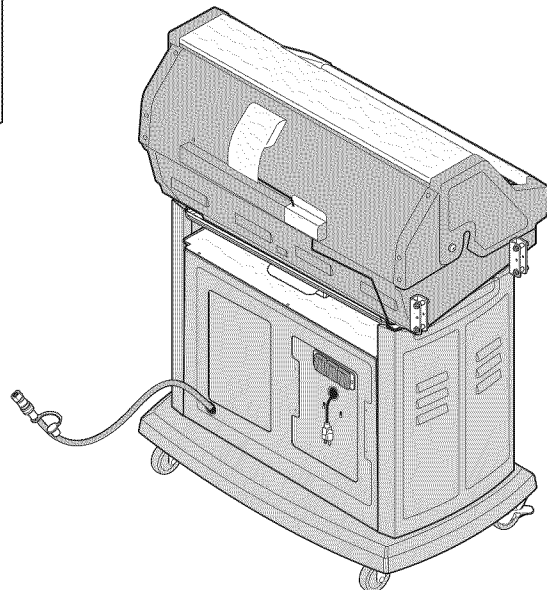
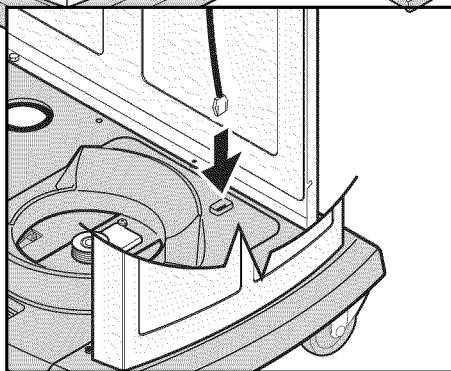

DANGER

DANGER: DO NOT PASS HOSE ABOVE SHIELD HOSE MUST NOT TOUCH ANY PART OF THE BASE

WARNING:

ENSURE HOSE ASSEMBLY DOES NOT CONTACT THE CASTING, OR ANY OTHER PARTS WHICH WILL GET HOT.

GRILL ASSEMBLY

FIG.13



SOME PARTS MAY HAVE SHARP EDGES OR BURRS. HANDLE WITH CARE.

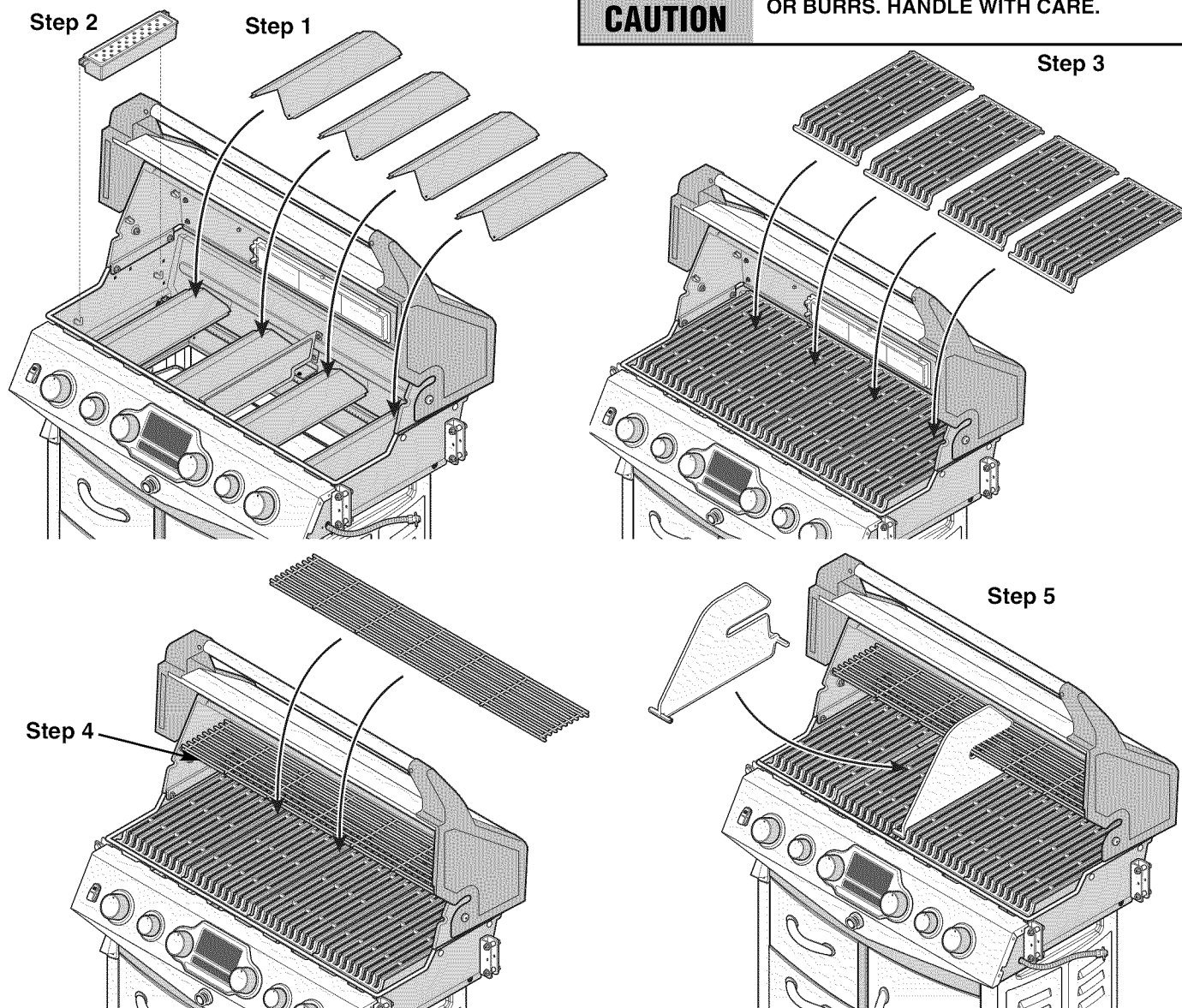

Step 1

- Rest the ends of heat plates & searing burner cover into notches inside casting as shown.

Step 2

- Install Smoker on hooks inside cover assembly.

Step 3

- Install 4 grids as shown.

Step 4

- Install warming rack into supports as shown.

Step 5

- Install upper grill divider as shown. Use when 2 cooking zones are required

Step 6

- Install AA BATTERY into ignitor, put - (negative) side of battery in first.

Step 6

IGNITOR
CAP

BATTERY

Put - (negative) side of battery in first



DANGER

BEFORE OPERATING YOUR NEW OUTDOOR GAS BARBECUE/GRILL WITH iQue CONTROLLER MAKE SURE YOU READ AND UNDERSTAND THIS OPERATION MANUAL COMPLETELY AND ENSURE THAT YOU CAREFULLY READ AND FOLLOW THE INSTRUCTIONS FOUND IN THE IQUE INSTRUCTION MANUAL - USER GUIDE.

SIDE SHELF ASSEMBLY

FIG.14

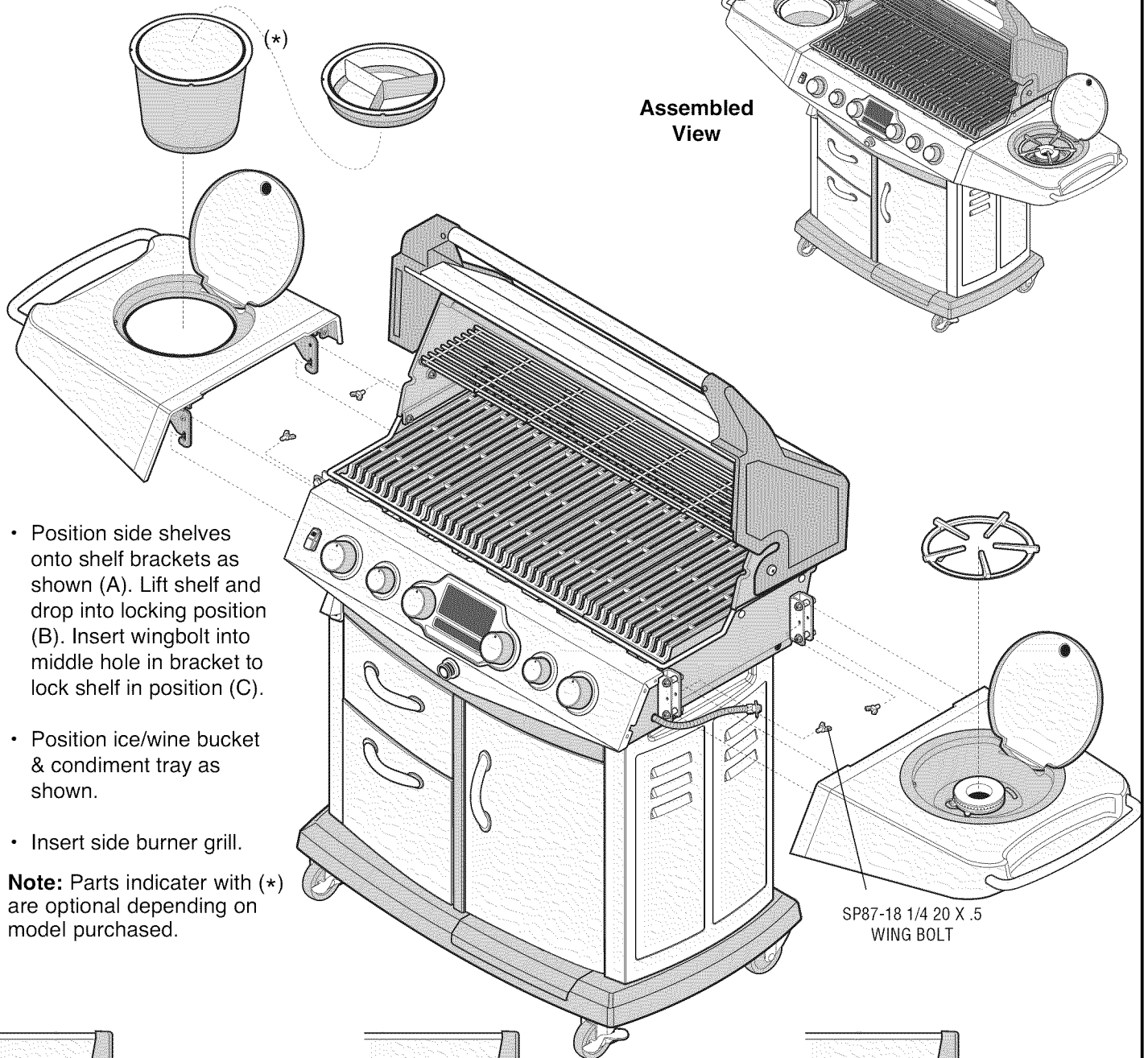

- Position side shelves onto shelf brackets as shown (A). Lift shelf and drop into locking position (B). Insert wingbolt into middle hole in bracket to lock shelf in position (C).
- Position ice/wine bucket & condiment tray as shown.
- Insert side burner grill.

Note: Parts indicator with (*) are optional depending on model purchased.

SP87-18 1/4 20 X .5
WING BOLT

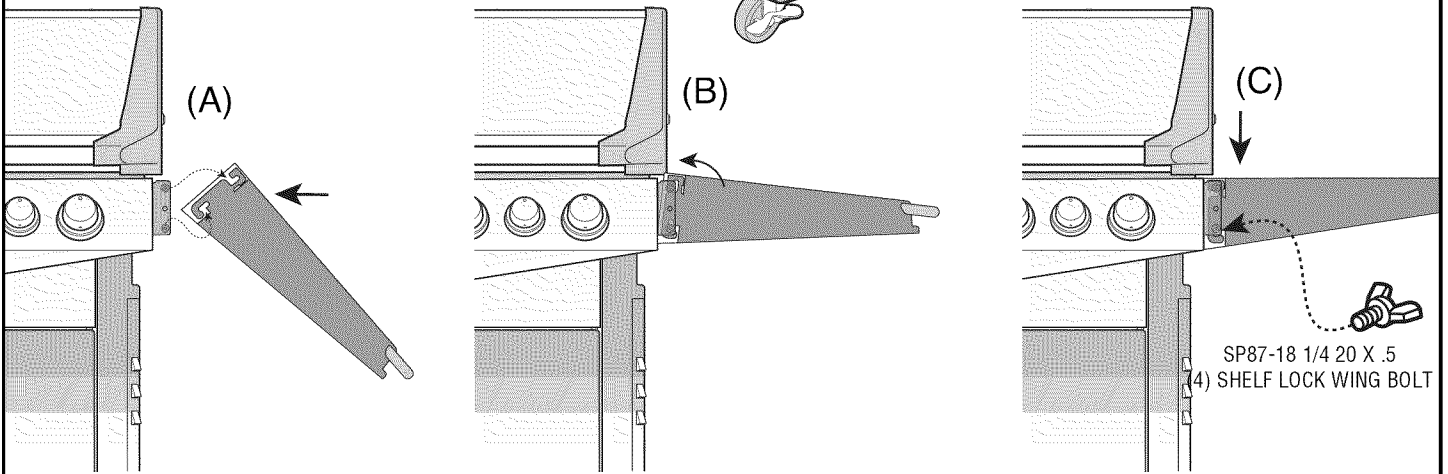

SP87-18 1/4 20 X .5
(4) SHELF LOCK WING BOLT

SIDE BURNER HOSE ASSEMBLY

- Position hose into end of side burner venturi tube until grooves line up (A). Snap clip into the groove on side burner tube to secure parts (B).
- Check hose to ensure it is securely positioned in tube end.
- Attach side burner Ignitor wire to terminal on side burner bracket. Ensure you read and understand warning below before proceeding.



CAUTION: NEVER LIGHT THE SIDE BURNER WHILE THE SIDE BURNER LID IS DOWN. THE SIDE BURNER LID SHOULD ALWAYS BE OPEN WHILE SIDE BURNER IS LIT. FAILURE TO DO SO MAY CAUSE SERIOUS BODILY INJURY AND/OR PROPERTY DAMAGE.

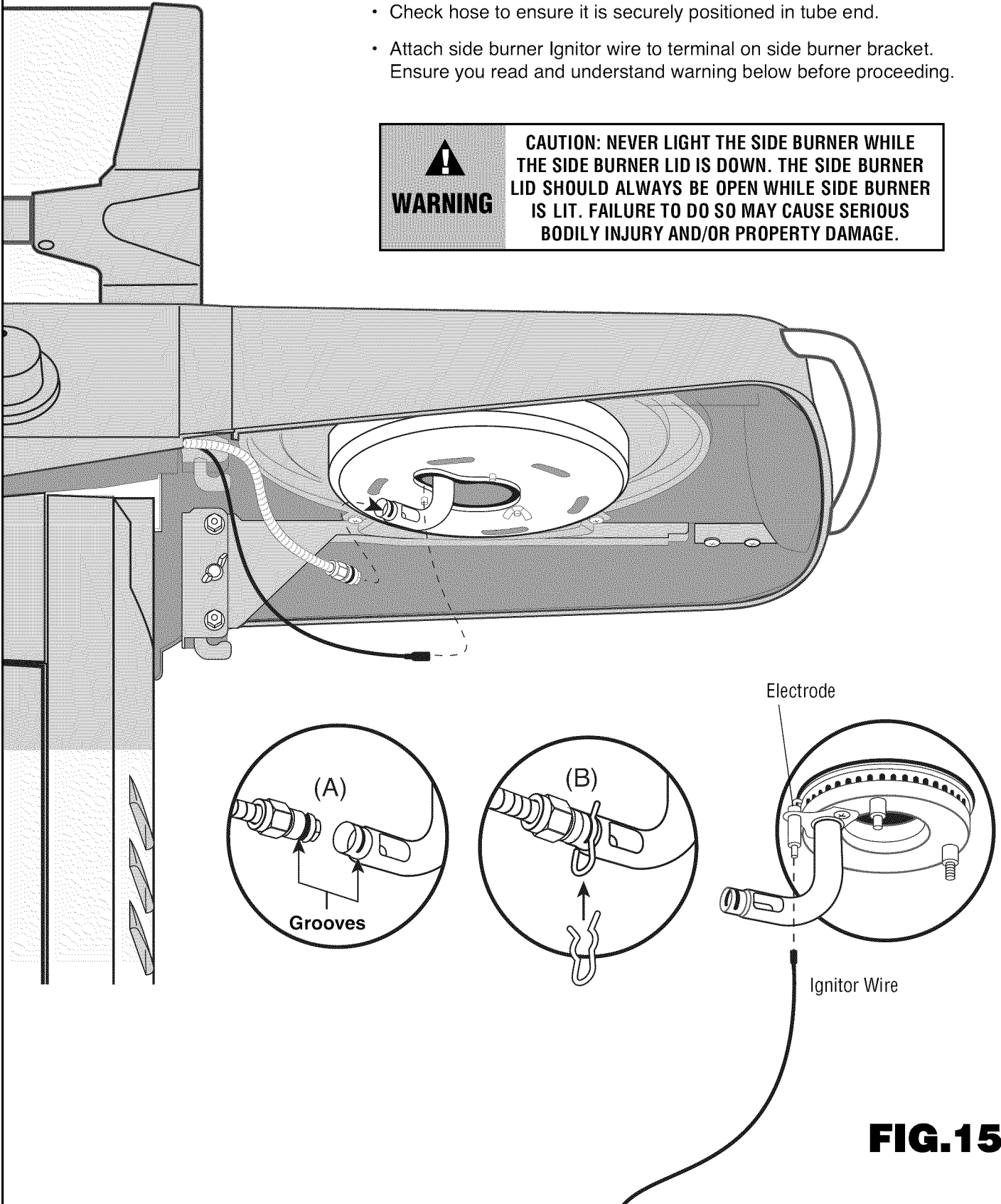

FIG.15

GREASE TRAP ASSEMBLY

- Assemble grease pan with brackets as shown using 10-b x .375 screw self tap screw.(IF NOT FACTORY INSTALLED)
- Slide in grease pan and Grease tray as shown fully forward.
- **Ensure grease trap and tray are in position before using the BBQ. (FULLY FORWARD)**

FIG.16



WARNING

ENSURE THAT GREASE PAN AND TRAY ARE EMPTIED PRIOR TO EACH USE. IF EXCESS GREASE IS ALLOWED TO ACCUMULATE, A POSSIBLE FIRE CAUSING PROPERTY DAMAGE OR SERIOUS INJURY MAY OCCUR.



WARNING

ENSURE GREASE TRAY AND PAN ARE FULLY LOCKED INTO POSITION BEFORE USING THE BBQ. FAILURE TO ENSURE THE ABOVE MAY RESULT IN A HAZARDOUS FIRE OR EXPLOSION CAUSING SERIOUS BODILY INJURY AND/OR PROPERTY DAMAGE & INVALIDATES WARRANTY

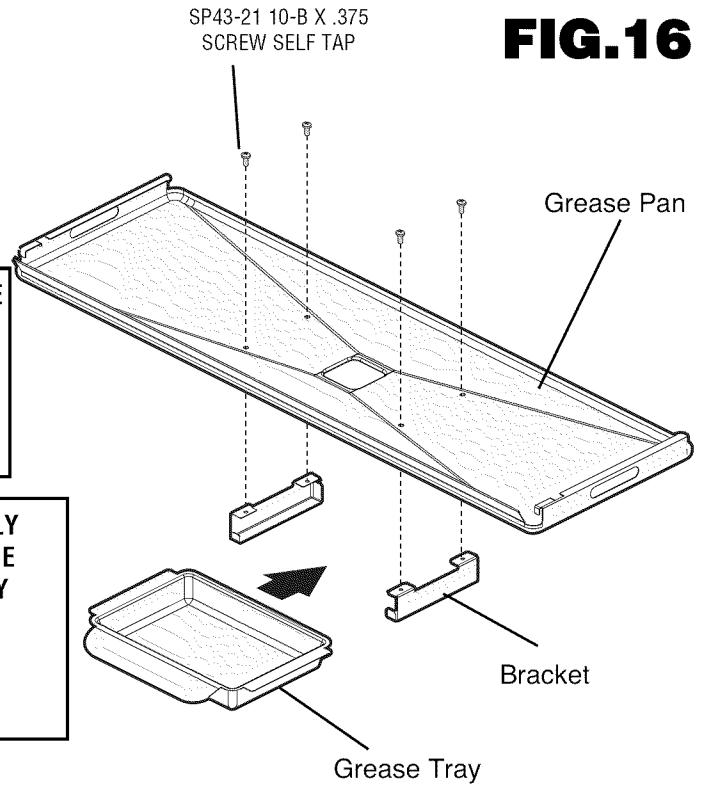

SP43-21 10-B X .375
SCREW SELF TAP (4)

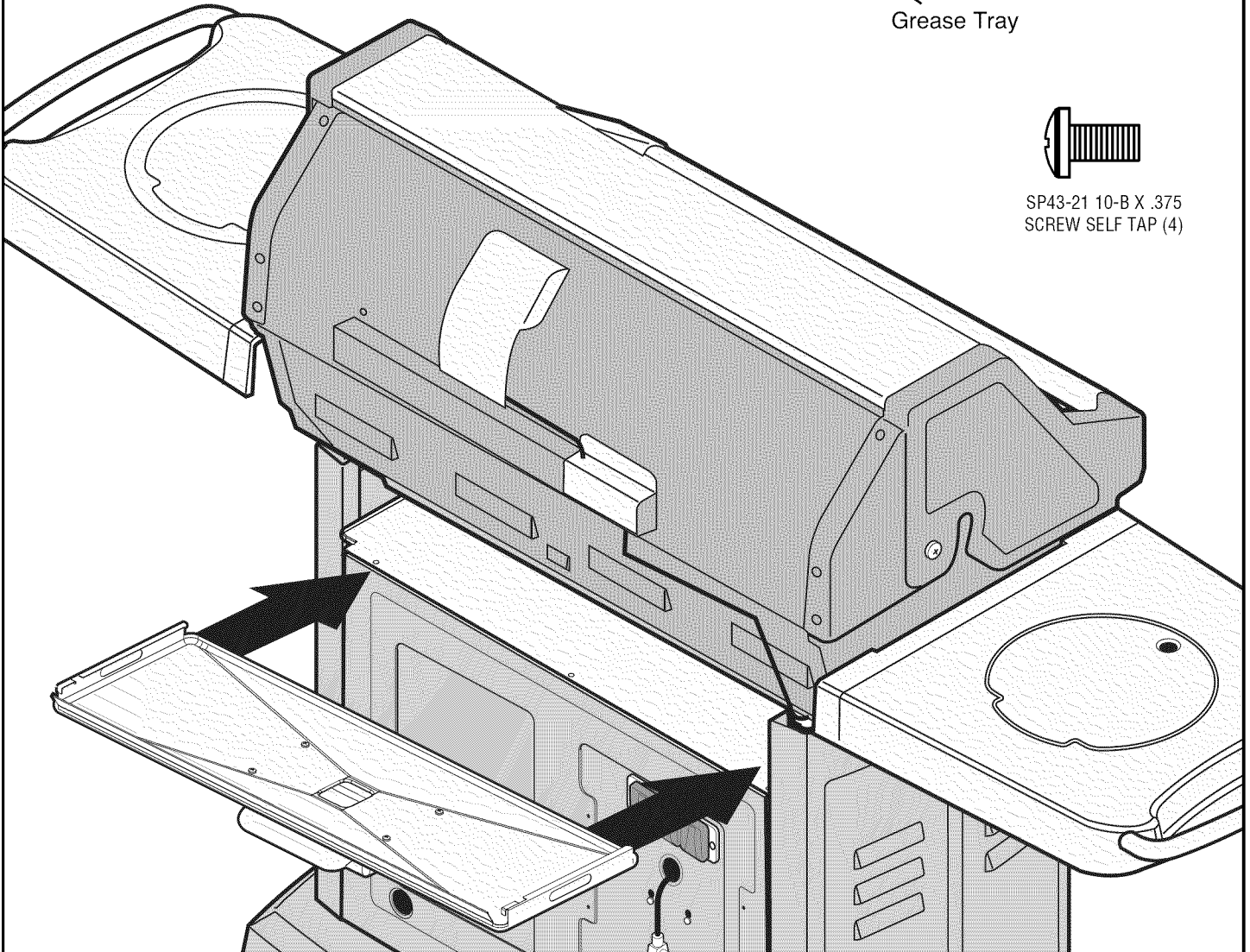

PROVIDING POWER TO YOUR BARBEQUE

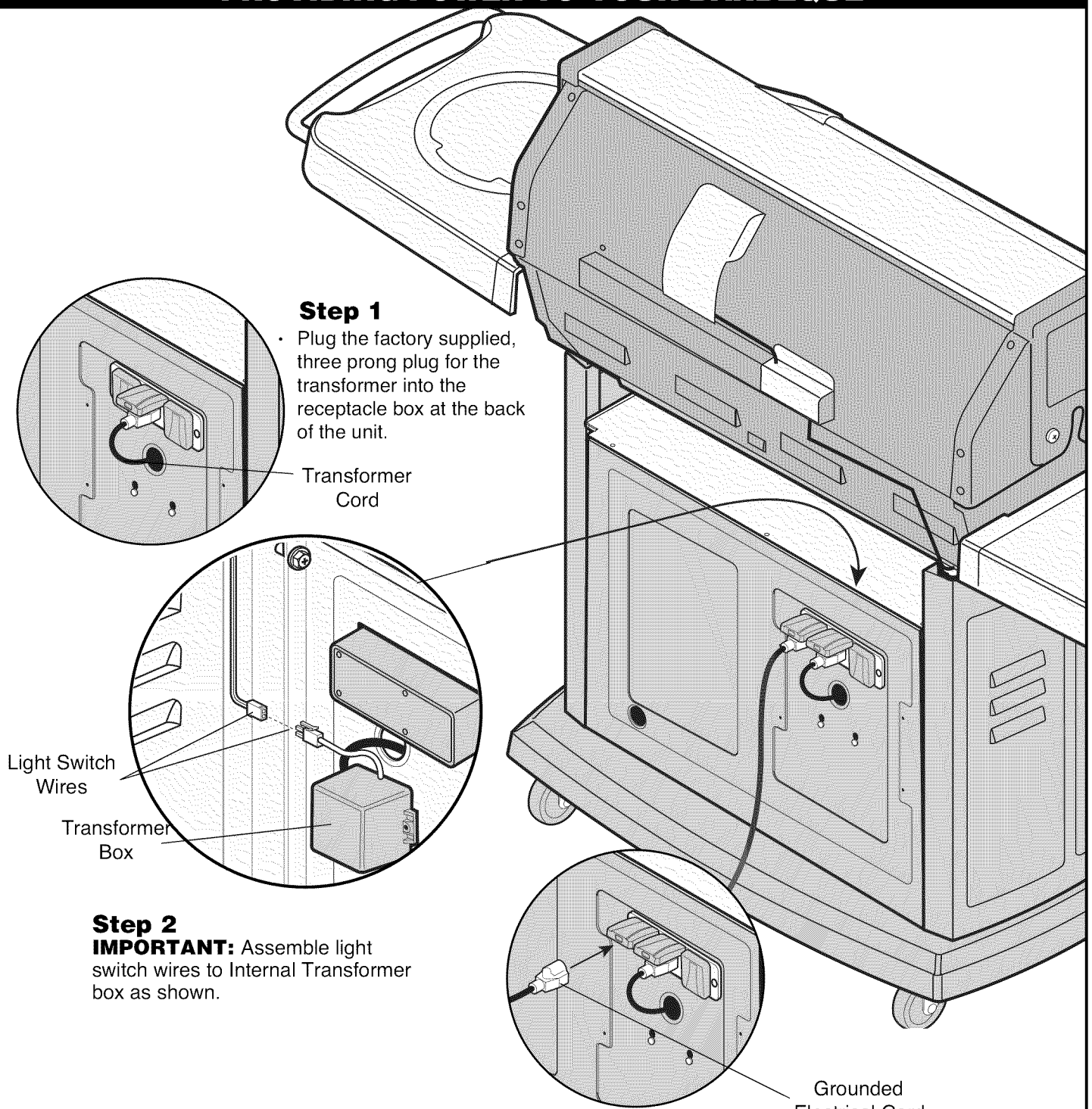

Step 1

- Plug the factory supplied, three prong plug for the transformer into the receptacle box at the back of the unit.

Transformer Cord

Step 2

IMPORTANT: Assemble light switch wires to Internal Transformer box as shown.

Light Switch Wires

Transformer Box

Grounded Electrical Cord

Step 3

IMPORTANT: To provide power to the barbecue, plug a grounded electrical cord into rear receptacle box as shown.

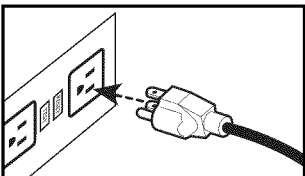

Plug electrical cord into properly grounded GFI (Ground Fault Interrupt) receptacle. If use of an extension cord is required, be sure that it is a minimum 16 AWG, 3 wire well insulated cord, marked for OUTDOOR USE ONLY and properly grounded.

CAUTION: To ensure continued protection against risk of electric shock, connect to properly earthed outlets only.

FIG.17

TANK & HOSE/REGULATOR ASSEMBLY

FOR PROPANE MODELS PLEASE FOLLOW FIG 18 & 19

- Position tank into tank support as shown.



THIS BARBECUE IS DESIGNED TO BE USED ONLY WITH A 20LB (9.1KG) PROPANE CYLINDER

FIG.18

WARNING: Before proceeding with the following steps, ensure you have read: • L.P. Gas Cylinder • Hose and Regulator

Sections of the **USE AND CARE INSTRUCTIONS** located at the front of this manual. The L.P. gas cylinder, if supplied with your grill, has been shipped empty for safety reasons. The cylinder must be purged of air, and filled, prior to use. Follow all directions under "**L.P. Gas Cylinder - Filling**" section of the **Use and Care Instructions**.

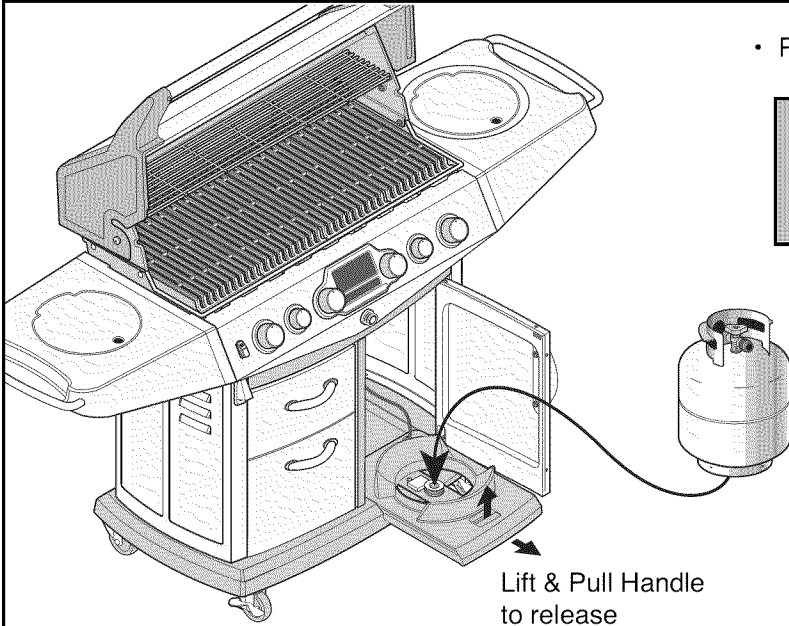

Lift & Pull Handle to release

Before attaching hose/regulator to tank, be sure cylinder valve and appliance valves are **OFF**.

The Q.C.C.1 cylinder has an internal back check module which will not allow gas to flow until a connection has been made. The valve is turned off by rotating the handwheel (Fig. 3, Use and Care) Clockwise (left to right) until it stops. When attaching regulator to tank, make sure that the small probe (Fig. 13) in the nipple is centered in the mating Q.C.C.1 cylinder valve, turn the right hand threaded Q.C.C.1 nut onto the valve in a clockwise motion until there is a positive stop. **DO NOT USE A WRENCH. HAND TIGHTEN ONLY.**

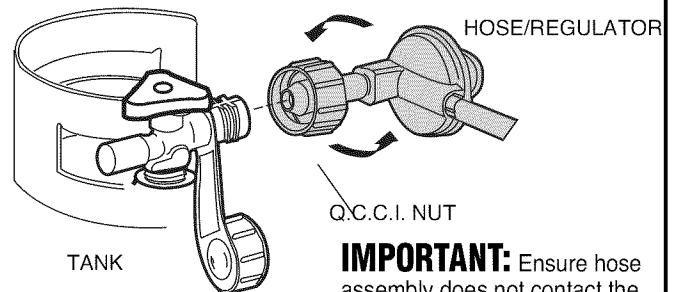

IMPORTANT: Ensure hose assembly does not contact the casting, or any other parts which will get hot.

FOR NATURAL GAS MODELS PLEASE FOLLOW STEP 20

FIG.20

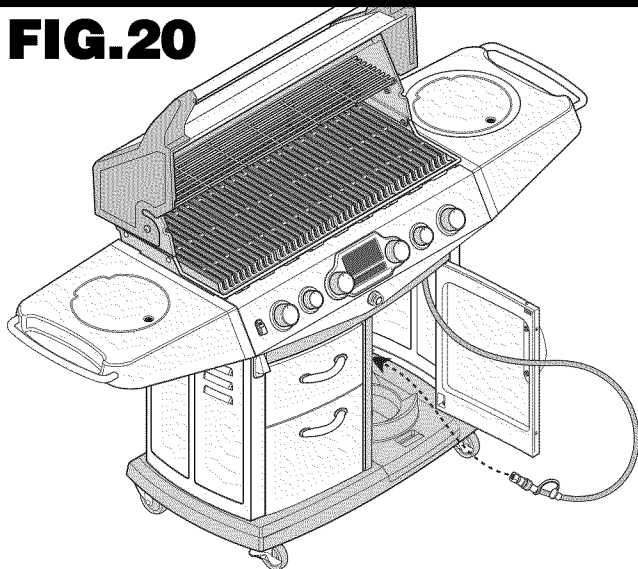

WARNING: Before proceeding with the following steps, ensure you have read: • **NATURAL GAS** sections of the **USE AND CARE INSTRUCTIONS**.

IMPORTANT: Ensure hose assembly does not contact the casting, or any other parts which will get hot.

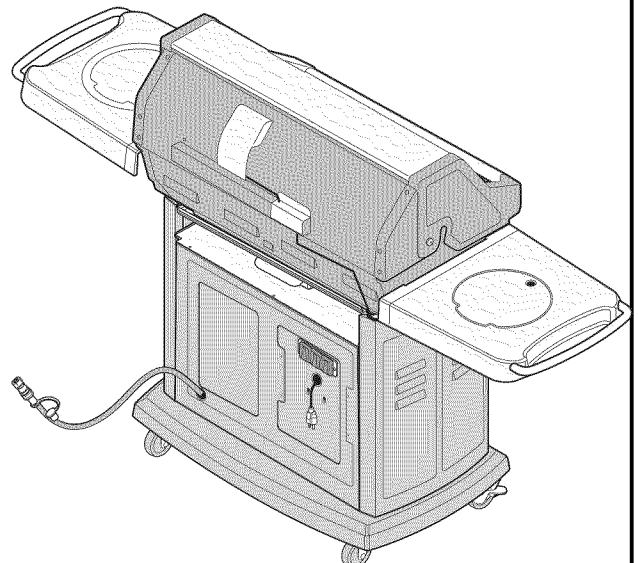

ROTISSERIE INSTALLATION

FIG.21

- Remove warming rack and cooking grills as needed.
- Slide rotisserie motor into bracket and assemble on the left side of the casting with 2 bolts and 2 nuts as shown.
- Assemble Rotisserie kit as shown.
- Plug the factory supplied, three prong plug for the rotisserie into the the receptacle box at the back of the unit.

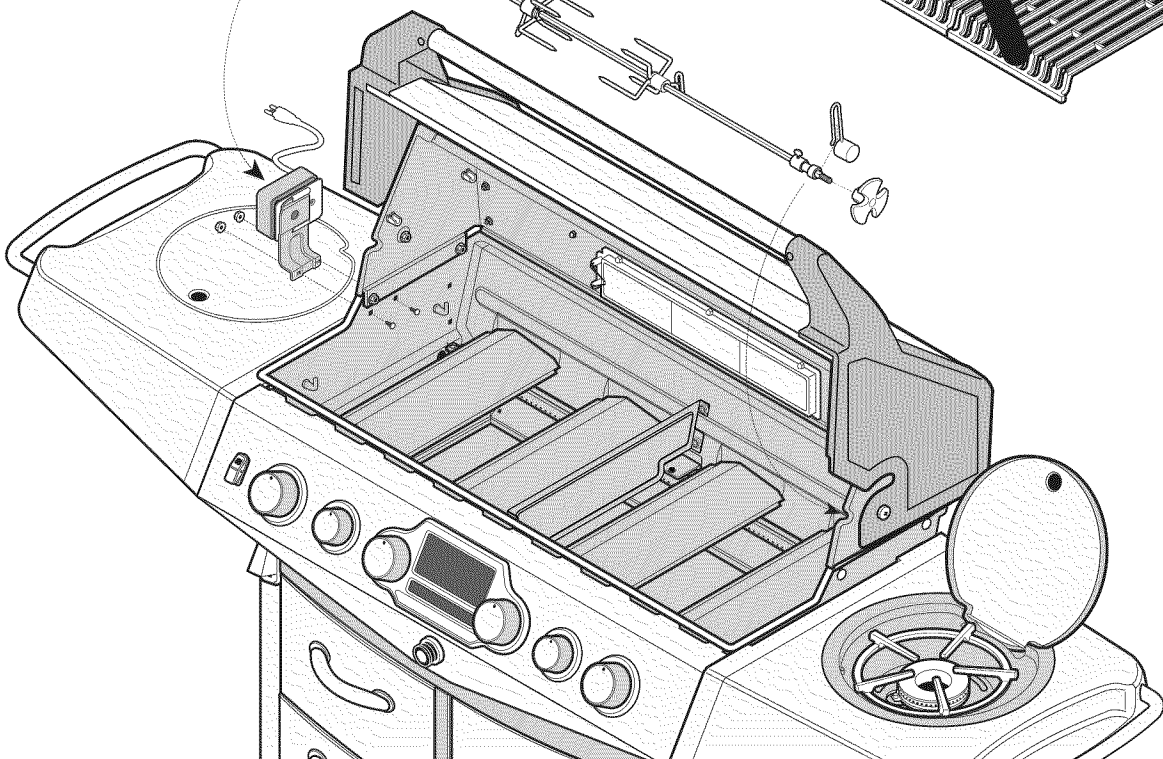
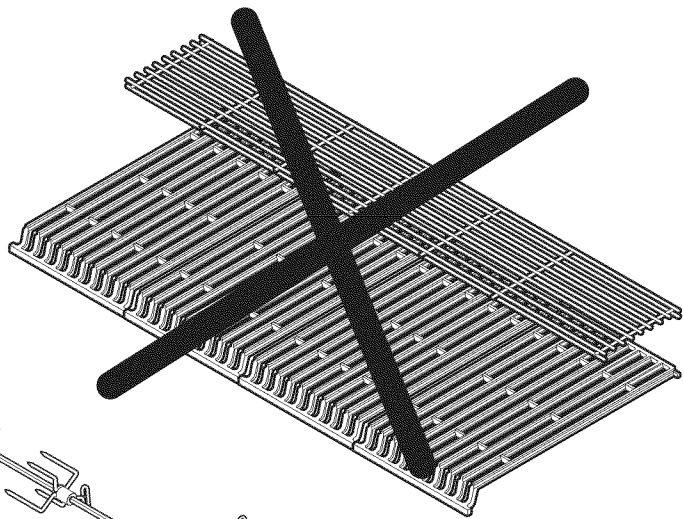
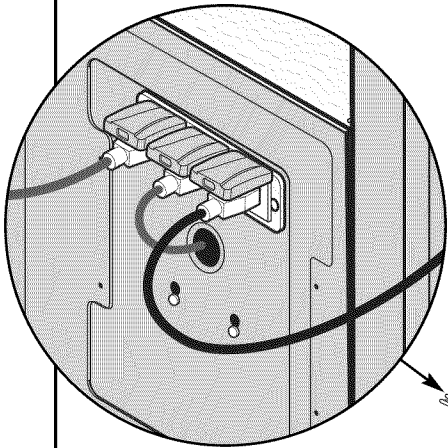
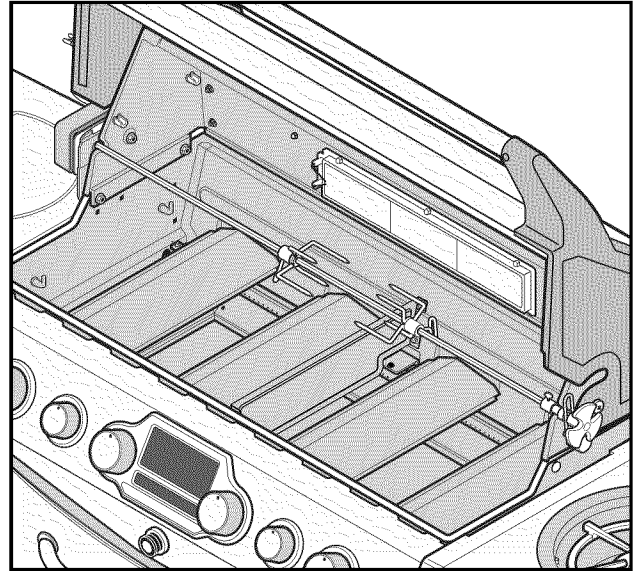

BULB REPLACEMENT INSTRUCTIONS

NOTE: UNPLUG ALL POWER TO GRILL BEFORE REPLACING LIGHT.

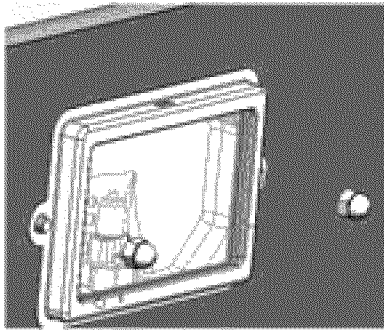

1. Loosen two nuts.

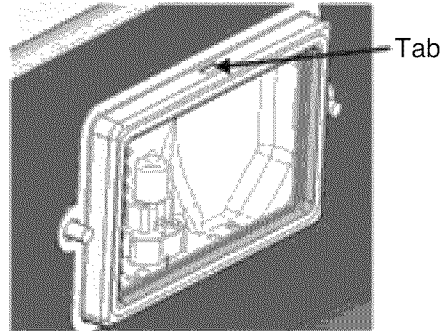

2. Press tab on top of Glass Bezel.

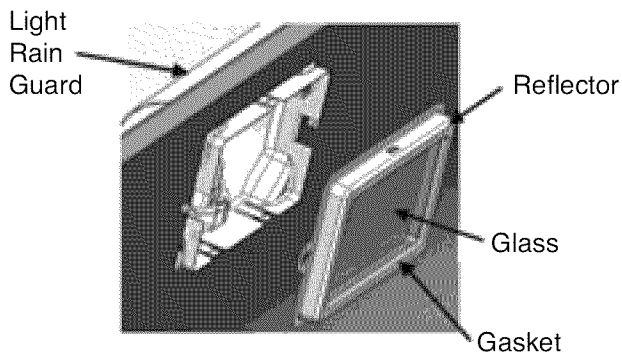

3. Hold the Light Rain Guard, slowly remove GLASS BEZEL, GLASS GASKET, and GLASS.

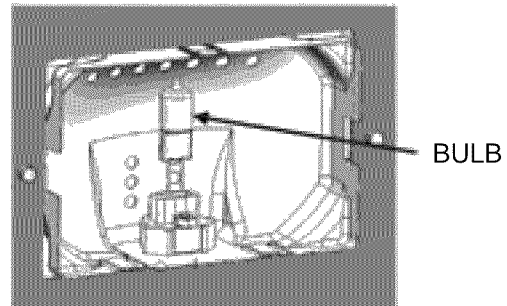

4. Hold the Light Rain Guard, remove the light BULB.

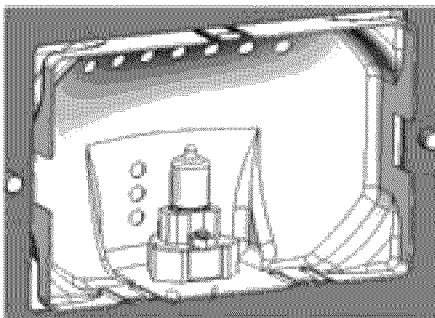

5. Hold the Light Rain Guard, replace the light BULB.

WARNING: When replacing bulb DO NOT TOUCH THE NEW BULB WITH BARE FINGERS.

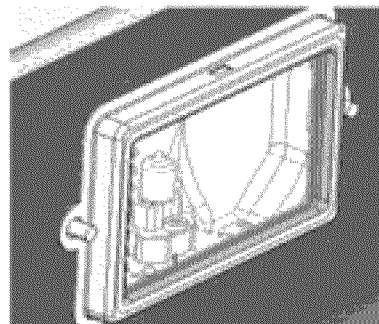

6. Hold the Light Rain Guard, place GLASS GASKET, GLASS, and GLASS BEZEL together into the REFLECTOR.

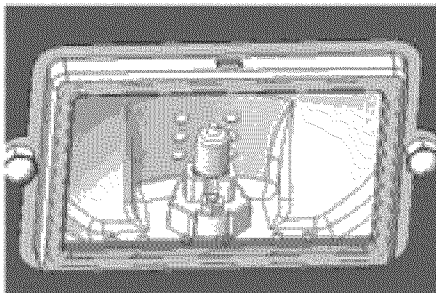

7. Secure nuts.

Bulb

USE 20 WATTS OR SMALLER,
12 VOLT, TYPE JC BULB.

ITEM	QTY.	SP PART No.	DESCRIPTION
1A	1	SP37-33C	Cover Cast. End Cap LH - Charcoal
1B	1	SP38-33C	Cover Cast. End Cap RH - Charcoal
1C	1	SP336-9B	Cover Panel - Black
1D	2	SP70-33	Cover Plug
1E	1	SP69-19	Handle
1F	2	SP8-25	Cover Post Stop
1G	1	SP57-30	Logo Gage Assembly
1H	2	SP61-16	Logo Gage Knurl Nut
2	2	SP54-21	#10-24 x 0.5" Truss Head SS Phillips Screw
3	8	SP40-16	Self-Thread Nut 1/4"
4	2	SP92-18	Cover Hinge Shoulder Bolt
5	36	SP53-16	1/4-20 Nut Hex Head Flanged
6A	1	SP39-33B	Cover Mount Cast End Cap LH - Black
6B	1	SP40-33B	Cover Mount Cast End Cap RH - Black
6C	1	SP326-9B	Panel Back - Black
6D	1	SP187-6	Upper Divider Bracket
6E	1	SP20-38	Light Assembly
6F	1	SP57-45	Bulb
6G	1	SP95-6B	Light Rain Guard - Black
6H	1	SP69-12	Rotisserie Burner Assembly
6I	1	SP55-20	Rotisserie Electrode Assembly
6J	1	SP51-6	Rotisserie Venturi Bracket
7	8	SP80-21	#8-32 x 0.275" Binding Head Slotted/Phillips Screw
8	18	SP82-18	#10-24 x 0.43" Carriage Bolt
9	22	SP41-16	#10-24 Nut Hex HD Flanged SS
10	10	SP44-16	#8-32 Acorn Nut
11	18	SP83-18	1/4-20 x 0.5" Carriage Bolt
12	1	SP321-9	Cast Upper Grill Divider
13	1	SP192-3	Warming Rack Porc. Coated
14A	1	SP41A-33C	Base Cast End Cap LH - Charcoal
14B	1	SP42A-33C	Base Cast End Cap RH - Charcoal
14C	1	SP325-9B	Base Back Panel - Black
14D	1	SP320-9B	Base Front Panel - Black
14E	2	SP188-6	Lower Divider Bracket
14F	1	SP323-9	Lower Divider Panel
14G	2	SP27-38	Temp. Probe Sensor
14H	4	SP54-6B	Base Shelf Brackets - Black
14I	1	SP257-9	Heat Baffle
14J	1	SP258-9	Console Baffle
15	12	SP42-21	#8-32 x .313 SS Pan Head Phillips Screw
16	3	SP10-16	#8-32 Hex Nut
17	8	SP85-18	3/8" Shouder Bolt - 1/4-20
18	1	SP27-18	#8-32 x .625 Round Head Phillips Screw
19	1	SP52-16	#8-32 Wing Nut
20	1	SP37-31C	FGQ Console 6 Valve (Charcoal) with SP5212-26 graphic
20A	2	SP46A-6	Bezel Main
20B	2	SP47A-6	Bezel Side Burner/Rotis
20C	5	SP15-7	Knob Main
20D	2	SP16-7	Knob Side Burner/Rotis
20E	1	SP15-38	Toggle Switch
20F	1	SP5001-38	Switch/Light Wire Harness - FG grills
21	8	SP81-21	#8-32 x 0.175" Pan Head Screw
22	1	SP22-38	I-Que Controller Assembly
22A	1	SP32-38	I-Que Electrical Harness
22B	1	SP28-38	External Meat Probe
22C	1	SP36-38	External Meat Probe Harness
23	6	SP82-21	#8-32 x 0.275" Pan Head Slotted/Phillips Screw
24	1	SP281-4	VHR 6-Valve Assy. I-Que 79,000 BTU - Propane
24A	1	SP5039-4	6- Valve Manifold Assy. - Propane
24B	1	SP83-11	Hose & Regulator for FG Grills 20" hose
24C	1	SP5365-42	Rotis. Tube Assembly for FG Grills - Propane
24D	1	SP5001-11	Corragated Side Burner Hose Assy. for FG650 Grills (LP)
24E	1	SP44-15	Clip for FG Side Burner Hose to Venturi
25	1	SP76-20	Ignitor Assy., Electronic 6-Pole
25A	1	SP5035-20	Nut for Ignitor Assy., Electronic 6-Pole
25B	1	SP5038-20	Bezel/Button (Bellows) for SP76-20 Ignitor Assy.
25C	1	SP5034-20	Side Burner Ignitor Wire 29-1/2" - FG Grills
26	34	SP43-21	#10-B x 0.375" Self Tap, Truss Head, Phillips Screw
27	1	SP115-12	Four Burner Assembly - FGQ65079
27A	4	SP113-12	Burner Tube Assembly - FGQ65079
27B	1	SP199-6	Burner Cross Ignitor Manual
27C	4	SP60-20	Electrode Assembly
27D	4	SP5037-20	Ground Wire, Main Burner Electrode FG grills
28	4	SP62-21	#8-B x 0.25" Truss Head Phillips Screw
29	4	SP44-21	#10-24 x 0.375" Hex Head Flanged Screw
30	2	SP45-21	#10 x 1" Hex Head Screw - Type B
31	1	SP182-6	Cross Over Brace
32	1	SP5385-42	Grease Pan Assembly - Stainless Steel - FG650
33	1	SP296-9	Grease Tray - Stainless Steel
34	4	SP94A-9	Smart Bar
35	4	SP164A-3	Cast Iron Cook Grate - Glossy Finish
36	1	SP284-9B	Cabinet Back Panel - Black
37	1	SP261-9B	Cabinet Front Panel - Black
38	1	SP262-9B	Panel RH Assembly - Black
39	4	SP46-21	1/4" x 0.5" Screw Hex Head Self Tap - Type B
40	1	SP285-9B	Panel LH Assembly - Black
41	1	SP309-9	Lower Heat Shield
42	1	SP171-6B	Front Bracket - Black
43	16	SP83-21	#10-24 x 0.5" Truss Head SS Phillips Screw

Gas Barbeque Grill: Model FGQ65079

HOW TO ORDER

SPARE PARTS:

When ordering, always give the following information:

1. The Part Number
2. The Model Description
3. The Serial Number
4. The Part Description
5. Part Color, B = Black, C = Charcoal, BL = Blue, E = Metallic Silver

NOTE: THE USE OF NON-MANUFACTURERS REPLACEMENT PARTS AUTOMATICALLY VOIDS THE BARBEQUE WARRANTY.

(X = COLOR, BL=BLUE, C=CHARCOAL, B=BLACK, E=Metallic Silver)

ITEM	QTY.	SP PART No.	DESCRIPTION
44	1	SP74-16	#10-24 K-Lock Hex Nut
45	1	SP168-6	Drawer Bracket Assembly (Left Hand)
46	4	SP170-6	Drawer Slide Assembly
47	1	SP172-6	Drawer Bracket Assembly (Right Hand)
48	1	SP266-9B	Bottom Pan Resin - Black
48A	4	SP28-22	Tank Caddy Wheels
49	4	SP107-18	3/8" x 3/8" - 1/4"-20 Shoulder Bolt
50	1	SP328-9C	Tank Caddy I-Que - Charcoal
50A	1	SP25-38	Tank Sensor Assembly
50B	1	SP161-6B	Tank Caddy Lock - Black
51	11	SP84-18	1/4"-20 x 0.5" Hex Head Bolt (Blk Zinc)
52	4	SP86-18	1/4"-20 x 0.75" Machine Screw
53A	1	SP342-9B	Upper Front Drawer Panel - Black
53B	1	SP271-9	Upper Drawer Liner
53C	1	SP343-9B	650 Upper Drawer - Black
54	12	SP57-21	#10-B x 1/2" Truss Head Phillips Screw
55	8	SP71-21	#8-32 x 5/16" Flat Head Phillips Screw
56	3	SP72-19	Drawer / Door Handle
57A	1	SP291-9	Lower Drawer Assembly
57B	1	SP340-9B	Lower Front Drawer Panel - Black
58	1	SP5362-42B	Door RH Assy. - FG650 (without Handle) - Black
59	1	SP41-15	Door Magnet
60	1	SP17-32	Door Hinge Pin (Lower)
61	2	SP32-22	Industrial Caster 3" - Locking (Blk. Finish)
62	2	SP31-22	Industrial Caster 3" - Non-Locking (Blk. Finish)
63	1	SP166-9B	Resin Side Shelf LH - Black
64	1	SP48-6B	Shelf Bracket LH - Black
65	1	SP49-6B	Shelf Bracket RH - Black
66	16	SP49-21	#10 x 0.75" Hex Flange Head Self Tap - Type AB
67	1	SP53-6	Shelf Trim LH
68	1	SP13-1B	Shelf Cover - Black
69	2	SP176A-3	Hinge Wire
70	2	SP55-19	Towel Bar
71	1	SP83-6	Tool Hook LH
72	4	SP87-18	1/4-20 x 0.5" Wing Bolt
73	1	SP12-2B	Side Burner Resin Base - Black
74	1	SP55-6	Shelf Trim RH
75	1	SP167-9	Side Burner Pan
76	1	SP13-1BG	Side Burner Lid - Black with SP1328-26 Graphic
77	1	SP60-16	Speed Nut - Push On
78	1	SP262-42B	Resin Side Burner Back Bracket Assembly - Black
79	1	SP263-42B	Resin Side Burner Front Bracket Assembly - Black
80	1	SP71-12	Brass Cover - Side Burner
81	1	SP5096-12	Side Burner Assembly (without Brass Cover)
81A	2	SP27-18	#8-32 x 5/8 Round Head Phillips Screw
82	1	SP64-21	#8-32 x 5/16" Pan Head Screw
83	1	SP200-3	Cast Iron Side Burner Grate
84	1	SP50-6	Bottle Opener
85	1	SP7-1	Smoker Cover
86	1	SP5-2	Smoker Base
87	2	SP48-21	#12 x 0.5" L-Screw
88	1	SP17-38	Resin 2-Outlet / 1 Inlet Box
89	7	SP43-16	#10-24 Hex Nut Stainless Steel
90	1	SP16-17	#10 Internal Tooth Lock Washer
91	1	SP29-38	Transformer
92	1	SP110A-9	Wine Bucket
93	1	SP111A-9	Condiment Tray
94	1	SP186-42	Rotisserie Kit
94A	2	SP147-3	Fork 4 Prong Assembly
94B	1	SP12-38	Rotisserie Motor
94C	1	SP62-19	Rotisserie Handle Assembly
94D	1	SP88-5	Rotisserie Rod Right Collar Assembly
94E	1	SP89-5	Counter Balance
94F	1	SP90-6	Rotisserie Motor Bracket
94G	2	SP88-18	#10-24 x 0.5" Carriage Bolt
94H	2	SP57-16	#10-24 Flange Hex Nut
94I	1	SP101-5	Rotisserie Rod Left Collar Assembly
95	1	SP195-3	Rotisserie Rod

Gas Barbeque Grill: Model FGQ65079

HOW TO ORDER SPARE PARTS:

When ordering, always give the following information:

1. The Part Number
2. The Model Description
3. The Serial Number
4. The Part Description
5. Part Color, B = Black, C = Charcoal, BL = Blue, E = Metallic Silver

**NOTE: THE USE OF
NON-MANUFACTURERS
REPLACEMENT PARTS
AUTOMATICALLY VOIDS
THE BARBEQUE
WARRANTY.**

(X = COLOR, BL=BLUE, C=CHARCOAL, B=BLACK, E=Metallic Silver)

BEFORE OPERATING THE BARBECUE FOR THE FIRST TIME

Grilling Safety Checklist

- Read and understand owners manual.
- Never overfill LP cylinder. Overfilled cylinders may cause freeze-up of regulator.
- Check tubes for spider webs. Ensure valves are correctly installed in burner tubes.
- Always ensure control knobs are in OFF position and regulator is attached to tank BEFORE opening tank valve to avoid low flames.
- Perform leak test regularly, including everytime a new cylinder is installed or replaced.
- Never leave your barbeque unattended while operating.
- Ensure proper clearances as outlined in your owners manual.
- Always refer to "Important Safeguards" found in owners manual.
- Ensure all electrical accessories (such as rotisserie) are grounded and keep any electrical cords and/or fuel supply hoses away from the grill box and any hot surfaces.

STOP

Should you encounter a problem with our product
Please refer to the Instruction Manual and Use & Care
If you still encounter a problem please contact customer service:

Do not return this product to the store.

WE CAN HELP

in Canada 1-888-267-2159

in USA 1-800-396-3838

Thank You for Your Purchase!



www.blueembergrills.com