

Item No. APG3090



# Owner's Manual 10,000 WATT GENERATOR



**Please read and save these instructions.**

**HAVE QUESTIONS OR NEED SERVICE  
DO NOT RETURN TO STORE!**

**PLEASE CALL TOLL FREE: 888.896.6881**



[www.allpoweramerica.com](http://www.allpoweramerica.com)

---

# 10,000W Generator

---

## Table of Contents

---

Topic	Page
Limited Warranty	3
Safety Guidelines	5
General Precautions	6
Controls	15
Pre-Operation Check	18
Operation	19
Servicing	21
Maintenance	22
Transporting/Storage	29
Assembly	30
Compliance	32
Specifications	33
Parts Listing	34

---



**WARNING! READ AND UNDERSTAND ALL SAFETY PRECAUTIONS IN THIS MANUAL BEFORE OPERATING. FAILURE TO COMPLY WITH INSTRUCTIONS IN THIS MANUAL COULD RESULT IN PERSONAL INJURY, PROPERTY DAMAGE, AND/ OR VOIDING OF YOUR WARRANTY. ALL-POWER WILL NOT BE LIABLE FOR ANY DAMAGE BECAUSE OF FAILURE TO FOLLOW THESE INSTRUCTIONS.**

---

# Owner's Manual

---

## Limited Warranty

All-Power warrants to the original purchaser who uses the product in a consumer application (personal, residential or household usage) that all products covered under this warranty are free from defects in material and workmanship for one year from the date of purchase. All products covered by this limited warranty which are used in commercial applications (i.e. income producing) are warranted to be free of defects in material and workmanship for 90 days from the date of original purchase. Products covered under this warranty include air compressors, air tools, service parts, pressure washers and generators.

All-Power will repair or replace, at All-Powers sole option, products or components which have failed within the warranty period. Service will be scheduled according to the normal work flow and business hours at the service center location, and the availability of replacement parts. All decisions of All-Power with regard to this limited warranty shall be final.

This warranty gives you specific legal rights, and you may also have other rights which vary from state to state.

RESPONSIBILITY OF ORIGINAL PURCHASER (initial User):

To process a warranty claim on this product, DO NOT return item to the retailer. The product must be evaluated by an Authorized Warranty Service Center. For the location of the nearest Authorized Warranty Service Center call toll free 888.896.6881.

**Retain original cash register sales receipt as proof of purchase for warranty to work.**

Use reasonable care in the operation and maintenance of the product as described in the Owner's Manual(s).

Deliver or ship the product to the Authorized Warranty Service Center. Freight costs, if any must be paid by the purchaser.

If the purchaser does not receive satisfactory results form the Authorized Warranty Sercive Center, the purchser should contact All-Power.

---

# 10,000W Generator

---

## Limited Warranty (cont'd)

THIS WARRANTY DOES NOT COVER:

- Merchandise sold as reconditioned, used as rental equipment or floor display models.
- Expendable parts or accessories supplied with the product which are expected to become inoperative or unusable after a reasonable period of use.
- Merchandise that has become damaged or inoperative because of ordinary wear, misuse, cold, heat, rain, excessive humidity, freeze damage, use of improper chemicals, negligence, accident, failure to operate the product in accordance with the instructions provided in the Owner's Manual(s) supplied with the product, improper maintenance, the use of accessories or attachments not recommended by All-Power, or unauthorized repair or alterations.
- Repair and transportation costs of merchandise determine not to be defective.
- Costs associated with assembly, required oil, adjustments or other installation and start-up costs.
- Merchandise sold by All-Power which has been manufactured by and identified as the product of another company, such as gasoline engines. The product manufacturer's warranty, if any, will apply.
- ANY INCIDENTAL, INDIRECT OR CONSEQUENTIAL LOSS, DAMAGE, OR EXPENSE THAT MAY RESULT FROM ANY DEFECTS, FAILURE OR MALFUNCTION OF THE PRODUCT IS NOT COVERED BY THIS WARRANTY. Some states do not allow the exclusion, so it may not apply to you.
- IMPLIED WARRANTIES, INCLUDING THOSE OF MERCHANTABILITY OR FITNESS FOR A PARTICULAR PURPOSE, ARE LIMITED TO ONE YEAR FROM THE DATE OF ORIGINAL PURCHASE. Some states do not allow limitations on how long an implied warranty lasts, so the above limitations may not apply to you.

---

# Owner's Manual

---

## Safety Guidelines - Definitions

This manual contains important information that you need to know and understand in order to protect YOUR SAFETY and to PREVENT EQUIPMENT PROBLEMS. The following symbols help you recognize this information. Please read the manual and pay attention to these sections.

### Save These Important Safety Instructions!

Read and understand all of these safety instructions. Be sure to retain them for future use.



**WARNING! WARNINGS INDICATE A CERTAINTY OR STRONG POSSIBILITY OF PERSONAL INJURY OR DEATH IF INSTRUCTIONS ARE NOT FOLLOWED.**



**CAUTION: CAUTIONS INDICATE A POSSIBILITY OF EQUIPMENT DAMAGE IF INSTRUCTIONS ARE NOT FOLLOWED.**



**NOTE: NOTES GIVE HELPFUL INFORMATION**



**WARNING! IMPROPER OPERATION OR MAINTENANCE OF THIS PRODUCT COULD RESULT IN SERIOUS INJURY AND PROPERTY DAMAGE. READ AND UNDERSTAND ALL WARNINGS AND OPERATING INSTRUCTIONS BEFORE USING THIS EQUIPMENT. WHEN USING AIR TOOLS, BASIC SAFETY PRECAUTIONS SHOULD ALWAYS BE FOLLOWED TO REDUCE THE RISK OF PERSONAL INJURY.**

---

# 10,000W Generator

---

## General Precautions



**WARNING! FAILURE TO FOLLOW THESE INSTRUCTIONS CAN RESULT IN SEVERE INJURY OR DEATH.**



**CAUTION: FAILURE TO FOLLOW THESE INSTRUCTIONS CAN ALSO RESULT IN DAMAGE TO THE TOOL AND/OR THE ITEM YOU ARE WORKING ON.**

## Carbon Monoxide



**WARNING! THE EXHAUST CONTAINS POISONOUS CARBON MONOXIDE GAS THAT CAN CAUSE LOSS OF CONSCIOUSNESS AND MAY LEAD TO DEATH.**



Using a generator indoors WILL KILL YOU IN MINUTES.

Generator exhaust contains high levels of carbon monoxide (CO), a poisonous gas you cannot see or smell. If you can smell the generator exhaust, you are breathing CO. But even if you cannot smell the exhaust, you could be breathing CO.

• NEVER use a generator inside homes, garages, crawlspaces, or other partly enclosed areas. Deadly levels of carbon monoxide can build up in these areas. Using a fan or opening windows and doors does NOT supply enough fresh air.

• ONLY use a generator outdoors and far away from open windows, doors, and vents. These openings can pull in generator exhaust. Even when you use a generator correctly, CO may leak into the home. ALWAYS use a battery-powered or battery-backup CO alarm in the home. If you start to feel sick, dizzy, or weak after the generator has been running, move to fresh air RIGHT AWAY. See a doctor. You could have carbon monoxide poisoning.

## Gasoline and Oil

This product requires oil and fuel. Attempting to start the engine without oil will ruin the engine and void the warranty. Work in well ventilated area. Keep cigarettes, flames or sparks away from the work area or where gasoline is stored.



**WARNING! GASOLINE IS EXTREMELY FLAMMABLE AND IS EXPLOSIVE UNDER CERTAIN CONDITIONS. KEEP OUT OF REACH OF CHILDREN.**

- Gasoline fuel and fumes are flammable and potentially explosive. Use proper fuel storage and handling procedures. Always have multiple ABC class fire extinguishers nearby.
- Keep the generator and surrounding area clean at all times.
- Fuel or oil spills must be cleaned up immediately. Dispose of fluids and cleaning materials as per any local, state, or federal codes and regulations. Store oily rags in a covered metal container.
- Never store fuel or other flammable materials near the generator.

---

# Owner's Manual

---

## General Precautions (cont'd)

### Gasoline and Oil (cont'd)

- Do not smoke, or allow sparks, flames or other sources of ignition around the engine and fuel tank. Fuel vapors are explosive.
- Keep grounded conductive objects, such as tools, away from exposed, live electrical parts and connections to avoid sparking or arcing. These events could ignite fumes or vapors.
- Do not refill the fuel tank while the engine is running or while the engine is still hot. Do not operate the generator with known leaks in the fuel system
- Excessive buildup of unburned fuel gases in the exhaust system can create a potentially explosive condition. This buildup can occur after repeated failed start attempts, valve testing, or hot engine shutdown. If this occurs, open exhaust system drain plugs, if equipped, and allow the gases to dissipate before attempting to restart the generator.
- Use only engine manufacturer recommended fuel and oil.

### Hot Components



**WARNING! ENGINE AND EXHAUST SYSTEM PARTS BECOME VERY HOT AND REMAIN HOT FOR SOME TIME AFTER THE ENGINE IS RUN. WEAR INSULATED GLOVES OR WAIT UNTIL THE ENGINE AND EXHAUST SYSTEM HAVE COOLED BEFORE HANDLING THESE PARTS.**

### Power Output

This generator is not designed to power sensitive electronic equipment (including computers and medical devices) without the addition of an approved line conditioner, which is sold separately.



**CAUTION: ATTEMPTING TO POWER SENSITIVE ELECTRONIC EQUIPMENT WITHOUT THE USE OF AN APPROVED LINE CONDITIONER MAY CAUSE DAMAGE TO THE EQUIPMENT. ALL POWER AMERICA IS NOT RESPONSIBLE FOR ANY DIRECT OR INDIRECT DAMAGE CAUSED BY FAILURE TO USE AN APPROVED LINE CONDITIONER.**

---

# 10,000W Generator

---

## General Precautions (cont'd)

### Work Area

- Keep your work area clean and well lit. Cluttered benches and dark areas invite accidents.
- Do not operate power tools in explosive atmospheres, such as in the presence of flammable liquids, gases, or dust. Generators create sparks which may ignite the dust or fumes.
- Keep bystanders, children, and visitors away while operating a generator. Provide barriers or shields as needed.

### Electrical Safety

- Grounded tools must be plugged into an outlet properly installed and grounded in accordance with all codes and ordinances. Never remove the grounding prong or modify the plug in any way. Do not use any adapter plugs.
- Grounding provides a low-resistance path to carry electricity away from the user in the event of an electrical malfunction.
- Double insulated tools are equipped with a polarized plug where one blade is wider than the other. This plug fits in a polarized outlet only one way. If the plug does not fit fully in the outlet, reverse the plug. If it still does not fit, contact a qualified electrician to install a polarized outlet. Do not change the plug in any way. Double insulation eliminates the need for the three-wire grounded power cord and grounded power supply system.
- Avoid body contact with grounded surfaces such as pipes, radiators, ranges, and refrigerators. There is an increased risk of electric shock if your body is grounded.
- Do not expose generator to rain or wet conditions. Water entering a generator will increase the risk of electric shock.
- Do not abuse the power cord. Keep power cords away from heat, oil, sharp edges, or moving parts. Replace damaged power cords immediately. Damaged power cords increase the risk of electric shock.
- When operating a power tool outside, use an outdoor extension cord marked "W-A" or "W". These extension cords are rated for outdoor use, and reduce the risk of electric shock.





---

# Owner's Manual

---

## General Precautions (cont'd)

### Electrical Safety (cont'd)

- All connections and conduits from the generator to the load must only be installed by trained and licensed electricians, and in compliance with all relevant local, state, and federal electrical codes and standards, and other regulations where applicable.
- The generator must be earth-grounded for fixed installations in accordance with all relevant electrical codes and standards before operation.
- Do not attempt to connect or disconnect load connections while standing in water, or on wet or soggy ground.
- Do not touch electrically energized parts of the generator and interconnecting cables or conductors with any part of the body, or with any non-insulated conductive object.
- Connect the generator only to a load or electrical system (120 volt) that is compatible with the electrical characteristics and rated capacities of the generator.
- Before servicing equipment powered by the generator, disconnect the equipment from its power input.
- Keep all electrical equipment clean and dry. Replace any wiring where the insulation is cracked, cut abraded or otherwise degraded. Replace terminals that are worn, discolored, or corroded. Keep terminals clean and tight.
- Insulate all connections and disconnected wires.
- Guard against electric shock. Prevent body contact with grounded surfaces such as pipes, radiators, ranges, and refrigerator enclosures.

### Personal Safety

- Stay alert. Watch what you are doing, and use common sense when operating a generator. Do not use generator while tired or under the influence of drugs, alcohol, or medication. A moment of inattention while operating generators may result in serious personal injury.
- Dress properly. Do not wear loose clothing or jewelry. Contain long hair. Keep your hair, clothing, and gloves away from moving parts. Loose clothes, jewelry, or long hair can be caught in moving parts.

---

# 10,000W Generator

---

## General Precautions (cont'd)

### Personal Safety (cont'd)

- Avoid accidental starting. Make sure the power switch is in its “OFF” position, and disconnect the spark plug wire when not in use.
- Remove adjusting keys or wrenches before turning the generator on. A wrench or a key that is left attached to a rotating part of the generator may result in personal injury.
- Do not overreach. Keep proper footing and balance at all times.
- Use safety equipment. Always wear eye protection. Wear ANSI approved safety impact eye goggles. Dust mask, non-skid safety shoes, hard hat, or hearing protection must be used for appropriate conditions.
- Do not force the generator. Use the correct generator for your application. The correct generator will do the job better and safer at the rate for which it is designed.
- Do not use the generator if the power switch does not turn it on or off. Any generator that cannot be controlled with the power switch is dangerous and must be replaced.

### Generator Use and Care

Make sure the power switch is in its “OFF” position and disconnect the spark plug wire before making any adjustment, changing accessories, or storing the generator. Such preventive safety measures reduce the risk of starting the generator accidentally.

Store idle generators out of reach of children and other untrained persons. Generators are dangerous in the hands of untrained users.

Maintain generators with care. Do not use damaged generator. Tag damaged generators “Do not use” until repaired.

Check for misalignment or binding of moving parts, breakage of parts, and any other condition that may affect the generator’s operation. If damaged, have the generator serviced before using. Many accidents are caused by poorly maintained generators.

Use only accessories that are recommended by the manufacturer for your model. Accessories that may be suitable for one generator may become hazardous when used on another generator.

---

# Owner's Manual

---

## General Precautions (cont'd)

### Servicing

Maintain labels and name plates on the generator and engine. These carry important information. If unreadable or missing, contact All-Power immediately for a replacement.

Generator service must be performed only qualified repair personnel. Service or maintenance performed by unqualified personnel could result in a risk of injury.

When servicing a generator, use only identical replacement parts. Follow all appropriate instructions in this manual. Use of unauthorized parts or failure to follow maintenance instructions may create a risk of electric shock or injury.

### Heart Pacemakers



**WARNING! PEOPLE WITH PACEMAKERS SHOULD CONSULT THEIR PHYSICIAN(S) BEFORE USING THIS PRODUCT. ELECTROMAGNETIC FIELDS IN CLOSE PROXIMITY TO A HEART PACEMAKER COULD CAUSE INTERFERENCE TO OR FAILURE OF THE PACEMAKER.**

### Installation

- Ensure installation meets all applicable safety, and local and national electrical codes. Have installation performed by a qualified, licensed electrician and building contractor.
- All electrical work, including the earth-ground connection, should be completed by a licensed electrician.
- Any separate fuel storage or generator supply facility must be built or installed in full compliance with all relevant local, state, and federal regulations.

---

# 10,000W Generator

---

## General Precautions (cont'd)

### Installation (cont'd)

#### Carbon Monoxide



**WARNING! THE EXHAUST CONTAINS POISONOUS CARBON MONOXIDE GAS THAT CAN CAUSE LOSS OF CONSCIOUSNESS AND MAY LEAD TO DEATH.**

Using a generator indoors WILL KILL YOU IN MINUTES.

Generator exhaust contains high levels of carbon monoxide (CO), a poisonous gas you cannot see or smell. If you can smell the generator exhaust, you are breathing CO. But even if you cannot smell the exhaust, you could be breathing CO.

· NEVER use a generator inside homes, garages, crawlspaces, or other partly enclosed areas. Deadly levels of carbon monoxide can build up in these areas. Using a fan or opening windows and doors does NOT supply enough fresh air.

· ONLY use a generator outdoors and far away from open windows, doors, and vents. These openings can pull in generator exhaust. Even when you use a generator correctly, CO may leak into the home. ALWAYS use a battery-powered or battery-backup CO alarm in the home. If you start to feel sick, dizzy, or weak after the generator has been running, move to fresh air RIGHT AWAY. See a doctor. You could have carbon monoxide poisoning.

- This generator is to be installed outdoors only, it must be weatherproofed and should be soundproofed. It should not be run outdoors without protection to the generator and wiring conduit.
- The generator weighs 253 lbs (approx). Two or more people should assist when moving or lifting this product. Never lift the generator using the engine or alternator lifting lugs. Connect lifting equipment to the frame of the generator
- Before lifting the generator, ensure the lift rigging and supporting structure are in good condition, and are rated to lift such a load.
- Keep all personnel away from the suspended generator during relocating.
- The supporting floor/ground surface should be level and strong enough to safely hold the weight of the generator. If the floor/grounded surface is not level, strong cross members should be placed under the full length of the generator frame at its low side.
- For trailer installation, the generator should be mounted on the center point of the trailer, over the wheels. The trailer must be capable of supporting the weight of the generator and all contents (tools, etc.)
- Install sound-and weather-proofing only when it is not raining or snowing to avoid trapping moisture within the generator's area.

---

# Owner's Manual

---

## General Precautions (cont'd)

### Mechanical

- Always make sure the power switch is in its "OFF" position. Disconnect the spark plug wire, and allow the engine to completely cool before carrying out maintenance.
- Check for damaged parts. Before using the generator, any part that appears damaged should be carefully checked to determine that it will operate properly and perform its intended function. Check for alignment and binding of moving parts, any broken parts or mounting fixtures, and any other condition that may affect proper operation technician.
- The generator is designed with guards for protection from moving parts. In any case, care must still be taken to protect personnel and equipment from other mechanical hazards when working around the generator.
- Do not operate the generator with safety guards removed. While the generator is running, do not attempt to reach around the safety guard for maintenance or any other reason.
- Keep hands, arms, long hair, loose clothing, and jewelry away from moving parts. Be aware that when engine parts are moving fast they cannot be seen clearly.
- Keep access doors on enclosures closed and locked when access is not required.
- When working on or around the generator always wear protective clothing including ANSI approved safety gloves, safety eye goggles, and safety hat.
- Do not alter or adjust any part of the generator that is assembled and supplied by the manufacturer.
- Always follow and complete scheduled engine and generator maintenance.

### Chemicals

- Avoid contact with hot fuel, oil, exhaust fumes, and hot solid surfaces.
- Avoid body contact with fuels, oils, and lubricants used in the generator. If swallowed, seek medical treatment immediately. Do not induce vomiting if fuel is swallowed. For skin contact, immediately wash with soap and water. For eye contact, immediately flush eyes with clean water and seek medical attention.

### Noise

- Prolonged exposure to noise levels above 68 DBA is hazardous to hearing. Always wear ANSI approved ear protection when operating or working around the generator when it is running.

---

# 10,000W Generator

---

## General Precautions (cont'd)

### Extension Cord

If an extension cord (not included) is used, make sure to use only UL approved cords having the correct gauge and length according to the following table:

Nameplate Amps (@ full load)	Cord Lengths			
	0 ft.- 50 ft.	50 ft.-100 ft.	100 ft.-150 ft.	150 ft.-200 ft.
0 - 5	16 AWG	16 AWG	12 AWG	12 AWG
5.1 - 8	16 AWG	14 AWG	10 AWG	-
8.1 - 12	14 AWG	12 AWG	-	-
12.1 - 15	12 AWG	10 AWG	-	-
15 - 20	10 AWG	10 AWG	-	-

---

---

# Owner's Manual

---

## Controls

### Engine Switch

To start and stop the engine

#### Switch position:

**OFF:** To stop the engine.

**ON:** To run the engine.

**START:** To start the engine (only for electric start) make sure the engine switch is in the "ON" position.

#### **NOTE**

If the start motor does not respond, please check the circuit breaker.

### Recoil Starter

To start the engine, pull the starter grip lightly until resistance is felt, then pull briskly.

#### **NOTE**

Do not allow the starter grip to snap back against the engine.

Return it gently to prevent damage to the starter.

### Fuel Valve

The fuel valve is located between the fuel tank and carburetor. When the fuel valve is in the "ON" position, fuel is allowed to flow from the fuel tank to the carburetor. Be sure to return the fuel valve lever to the OFF position after stopping the engine.

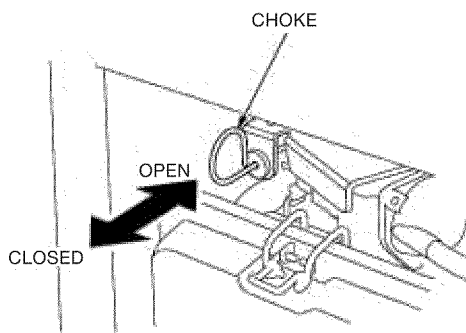

#### **NOTE**

- Turn OFF fuel valve when transporting the generator.
- Turn OFF the fuel valve when the generator is not in use.

---

# 10,000W Generator

---

## Controls (cont)

### Choke Rod

The choke is used to provide an enriched fuel mixture when starting a cold engine. It can be opened and closed by operating the choke lever manually. Pull the rod out toward CLOSED to enrich the mixture for cold starting.

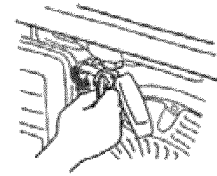

### Ground Terminal

The generator ground terminal is connected to the frame of the generator, the metal non-current carrying parts of the generator, and the ground terminals of each receptacle. Before using the ground terminal, consult a qualified electrician, electrical inspector or local agency having jurisdiction for local codes or ordinances that apply to the intended use of the generator.

### Oil Alert System

The oil alert system is designed to prevent engine damage caused by an insufficient amount of oil in the crankcase. Before the oil level in the crankcase can fall below a safe limit, the Oil Alert System will automatically stop the engine (the engine switch will remain in the ON position). The Oil Alert System should not take place of checking the oil level before each use. If engine stops or does not restart, check the engine oil level before troubleshooting in other areas.

## CIRCUIT BREAKER

**Turn the circuit breaker OFF before starting the generator.**

The AC circuit breaker will automatically switch OFF if there is a short circuit or a significant overload of the generator at the receptacle. If the AC circuit breaker is switched OFF automatically, check that the appliance is working properly and does not exceed the rated load capacity of the AC circuit before switching the circuit breaker ON again.

**Turn the circuit breaker OFF before stopping the generator.**

The circuit breaker may be used to switch the generator AC power ON or OFF.

### Voltage selector switch (only for dual voltage system)

The Voltage selector switch, switches the main power carrying windings of the generator to produce "120V ONLY" or "120V/240V". If a 240V appliance is connected to the 4-prong receptacle, the switch must be in the "120/240V" position. If only a 120V appliance is being connected to any of the 120V 3-prong receptacles, select the "120V ONLY" position.



---

# Owner's Manual

---

## Controls (cont)

### Switch Position

The voltage selector switches the main power carrying windings of the generator to produce 120V ONLY or 120/240V.

120V ONLY: ONLY the 120V receptacles can be used. Do not use the 120/240V receptacle in this position. The most power will be available at the 30A 120V locking plug receptacle.

This unit does not have a voltage select switch.

### AC Applications

Before connecting an appliance or power cord to the generator:

- Make sure that it is in good working order. Faulty appliances or power cords can create a potential for electrical shock.
- If an appliance begins to operate abnormally, becomes sluggish or stops suddenly, turn it off immediately. Disconnect the appliance, and determine whether the problem is the appliance, or if the rated load capacity of the generator has been exceeded.
- Make sure that the electrical rating of the tool or appliance does not exceed that of the generator. Never exceed the maximum power rating of the generator. Power levels between rated and maximum may be used for no more than 30 minutes.

### NOTE

Substantial overloading will open the circuit breaker. Exceeding the time limit for maximum power operation or slightly overloading the generator may not switch the circuit breaker OFF, but will shorten the service life of the generator.

---

# 10,000W Generator

---

## Controls (cont)

### AC Operation

1. Start the engine (see page 16).
2. Switch ON the AC circuit breaker.
3. Plug in the appliance .

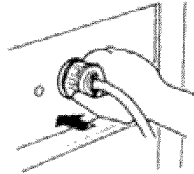

### NOTE

- Be sure that all appliances are in good working order before connecting them to the generator. If an appliance begins to operate abnormally, becomes sluggish, or stops suddenly, turn off the engine switch immediately. Then disconnect the appliance and examine it for signs of malfunction.
- Most motorized appliances require more than rated wattage for startup. Do not exceed the current limit specified for any one receptacle. If an overloaded circuit causes the AC circuit breaker to switch OFF, reduce the electrical load on the circuit, wait a few minutes and then reset the circuit breaker.

## Pre-Operation Check

### ENGINE OIL

### NOTE

Engine oil is a major factor affecting engine performance and service life. Non-detergent and 2-stroke engine oils will damage the engine and are not recommended.

Check the oil level BEFORE EACH USE with the generator on a level surface and the engine stopped. Use 4-stroke motor oil that meets or exceeds the requirements for API service classification SJ. Always check the API SERVICE label on the oil container to be sure it includes the letters SJ.

SAE 10W-30 is recommended for general, all-temperature use. Other viscosities shown in the chart may be used when the average temperature in your area is within the indicated range.

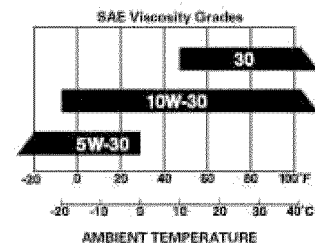

- **Check the engine oil before use**

---

# Owner's Manual

---

## Operation

### Pre-Operation Check

1. Remove the oil filler cap and wipe the dipstick clean.
2. Check the oil level by inserting the dipstick into the filler neck without screwing it in.
4. If the level is low, fill to the top of the oil filler neck with the recommended oil.

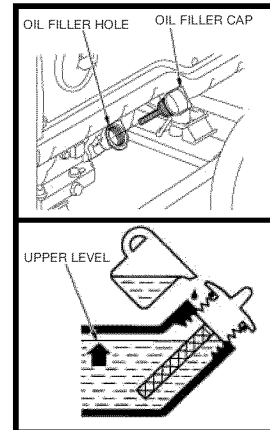

## Fuel

Check the fuel gauge, and refill the tank if the fuel level is low. Make sure it has at least 3 gallons of fuel before starting your new generator. Refuel carefully to avoid spilling fuel. Do not fill above the shoulder of the fuel strainer.



### WARNING

Gasoline is highly flammable and explosive, and you can be burned or seriously injured when refueling.

- Stop engine and keep heat, sparks, and flame away.
- Refuel only outdoors.
- Wipe up spills immediately.

Fuel tank capacity:

30L 8 gallon

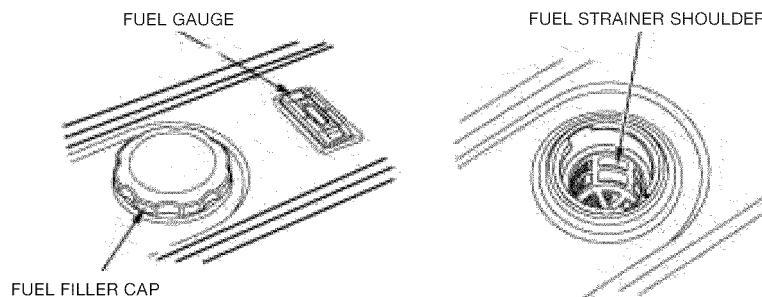

---

# 10,000W Generator

---

## Operation

### Pre-Operation Check



Fuel can damage paint and plastic. Be careful not to spill fuel when filling your fuel tank. Damage caused by spilling fuel is not covered under warranty. Use unleaded gasoline with a pump octane of 86 or higher. This engine is certified to operate on unleaded gasoline. Unleaded gasoline produces fewer engine and spark plug deposits and extends exhaust system life, Never use stale or contaminated gasoline or oil/gasoline mixture. Avoid getting dirt or water in the fuel tank. Occasionally you may hear a light “Spark knock” or “pinging” (metallic rapping noise) while operating under heavy loads. This is no cause for concern. If spark knock or pinging occurs at a steady engine speed, under normal load, change brands of gasoline. If spark knock or pinging persists, call our service center.

## STARTING THE ENGINE/STOPPING THE ENGINE

### Starting the Engine

1. Make sure that the AC circuit breaker is in the OFF position. The generator may be hard to start if a load is connected.
2. Turn the fuel valve lever to the ON position.
3. Put the choke to the CLOSED position.
4. Put the engine switch to the ON position.
5. Pull the starter grip lightly until resistance is felt, then pull briskly.



Do not allow the starter grip to snap back against the engine. Return it gently to prevent damage to the starter or housing.

6. As the engine warms up, slowly push the choke rod to the OPEN position.

### Stopping the engine

#### In an emergency:

To stop the generator in an emergency, turn the engine switch to the OFF position.

#### In normal use:

1. Turn the AC circuit breaker to the OFF position.
2. Turn the engine switch to the OFF position.
3. Turn the fuel valve lever to the OFF position.

# Owner's Manual

## Servicing







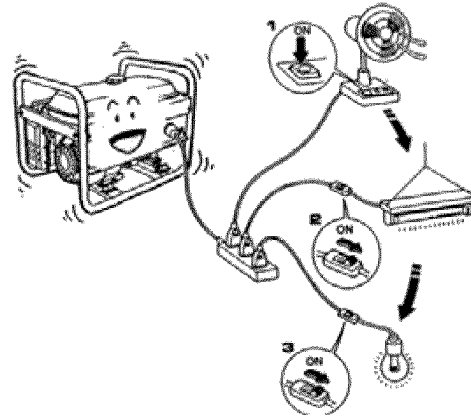
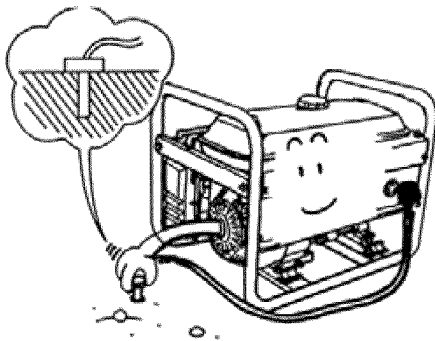

Always do the following to keep the generator in good condition.

### **WARNING**

1. Always ground your generator



2. The following table gives reference information for connecting the electric appliances to the generator.

Description	Wattage		Typifier	Example		
	Start	Rating		Electric device	Start	Rating
<ul style="list-style-type: none"> <li>● Incandescent lamp</li> <li>● Heating device</li> </ul>	× 1	× 1	 Incandescent lamp   TV	 Incandescent lamp  100W	100V A (W)	100V A (W)
<ul style="list-style-type: none"> <li>● Fluorescent lamp</li> </ul>	× 2	× 1.5	 Fluorescent lamp	 40W Fluorescent lamp	80V A (W)	60V A (W)
<ul style="list-style-type: none"> <li>● Drive device</li> </ul>	× 3 ~ 5	× 2	 Refrigerator   Electric fan	 Refrigerator 150W	450 ~ 750V A (W)	300V A (W)

---

# 10,000W Generator

---

## Maintenance

Good maintenance is essential for safe, economical, and trouble-free operation. It will also help reduce air pollution.



### WARNING

Improper maintenance, or failure to correct a problem before operation, can cause malfunction in which you can be seriously hurt or killed. Always follow the inspection and maintenance recommendations and schedules in this owner's manual.

To help you properly care for your generator, the following pages include a maintenance schedule, routine inspection procedures, and simple maintenance procedures using basic hand tools. Other service tasks that are more difficult, or require special tools, are best handled by professionals and are normally performed by generators or other qualified mechanics. The maintenance schedule applies to normal operating conditions. If you operate your generator under severe conditions, such as sustained high-load or high-temperature operation, or use it in unusually wet or dusty conditions, consult your servicing needs and use.

Maintenance, replacement, or repair of the emission control devices and systems may be performed by any engine repair establishment or individual, using parts that are certified to EPA standards.

## Maintenance Safety

Some of the most important safety precautions follow. However, we cannot warn you of every conceivable hazard that can arise in performing maintenance. Only you can decide whether or not you should perform a given task.



### WARNING

Failure to properly follow maintenance instructions and precautions can cause you to be seriously hurt or killed. Always follow the procedures and precautions in the owner's manual.

## Safety Precautions

- Make sure the engine is OFF before you begin any maintenance or repairs. This will eliminate several potential hazards:

**Carbon Monoxide Poisoning** from engine exhaust.

Be sure there is adequate ventilation whenever you operate the engine.

**Burns from hot parts.**

Let the engine and exhaust system cool before touching.

---

# Owner's Manual

---

## Maintenance

### Injury From Moving Parts.

Do not run the engine unless instructed to do so.

- Read the instructions before you begin, and make sure you have the tools and skills required.
- To reduce the possibility of fire or explosion. Use extreme caution when working around gasoline. Use only a nonflammable solvent, not gasoline, to clean parts. Keep cigarettes, sparks and flames away from all fuel-related parts.

Remember that your servicing dealer knows your generator best and is fully equipped to maintain and repair it. To ensure the best quality and reliability, use only new, genuine parts or their equivalents for repair or replacement.

### Emission Control System Information

The combustion process produces carbon monoxide, oxides of nitrogen, and hydrocarbons. Control of hydrocarbons and oxides of nitrogen is very important because, under certain conditions, they react to form photochemical smog when subjected to sunlight. Carbon monoxide does not react in the same way, but it is toxic. Engine utilizes lean carburetor setting and other systems to reduce the emissions of carbon monoxide, oxides of nitrogen, and hydrocarbons.

### Tampering and Altering

Tampering with or altering the emission control system may increase emissions beyond the legal limit. Among those acts that constitute tampering are:

- Removal or alteration of any part of the intake, fuel, or exhaust systems.
- Altering or defeating the governor linkage or speed-adjusting mechanism to cause the engine to operate outside its design parameters.

### Problems That May Affect Emissions

If you are aware of any of the following symptoms, have your engine inspected and repaired by your servicing dealer.

- Hard starting or stalling after starting.
- Rough idle.
- Misfiring or backfiring under load.
- Afterburning(backfiring).
- Black exhaust smoke or high fuel consumption.

# 10,000W Generator

## Maintenance

### Replacement Parts

The emission control systems on your generators were designed, built, and certified to conform with EPA and California emission regulations. We recommend the use of generators parts whenever you have maintenance done. These original-design replacement parts are manufactured to the same standards as the original parts, so you can be confident of their performance. The use of replacement parts that are not of the original design and quality may impair the effectiveness of your emission control system.

A manufacturer of an aftermarket part assumes the responsibility that the part will not adversely affect emission performance. The manufacturer or rebuild of the part must certify that use of the part will not result in a failure of the engine to comply with emission regulations.

Follow the maintenance schedule on page 12. Remember that this schedule is based on the assumption that your machine will be used for its designed purpose. Sustained high-load or high-temperature operation, or use in unusually wet or dusty conditions, will require more frequent service.

### Maintenance Schedule

REGULAR SERVICE PERIOD		Before each use	First month or 20 Hrs.	Every 3 months or 50 Hrs.	Every 6 months or 100 Hrs.	Every year or 300 Hrs.
ITEM Performed at every indicated Month or operating hour interval, whichever comes first						
Engine oil	Check level	○				
	Change		○		○	
Air filter	Check	○				
	Clean			○ (1)		
	Replace					○ *
Spark plug	Check-adjust				○	
	Replace					○
Spark arrester	Clean				○	
Idle speed	Check-adjust					○ (2)
Valve clearance	Check-adjust					○ (2)
Combustion chamber	Clean	After every 500Hrs. (2)				
Fuel tank and filter	Clean				○ (2)	
Fuel tube	Check	Every 2 years (Replace if necessary) (2)				



---

# Owner's Manual

---

## Maintenance

### Replacement Parts

- Emission related items.

- (1) Service more frequently when used in dusty areas.
- (2) These items should be serviced by an authorized service center, unless the owner has the proper tools and is mechanically proficient.
- (3) For commercial use, long hours of operation to determine proper maintenance intervals.

### ENGINE OIL CHANGE

Drain the oil while the engine is warm to assure rapid and complete draining.

1. Remove the oil filler cap,
2. Remove the drain plug, sealing washer and drain the oil.
3. Reinstall the drain plug and sealing washer. Tighten the plug securely.
4. Refill with oil and check the oil level.

**Oil capacity: 1.2 qt. (1.1L)**

OIL DRAIN PLUG

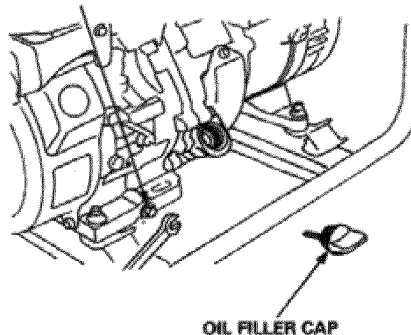

UPPER LEVEL

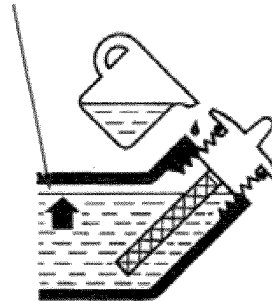

### NOTE

Wash your hands with soap and water after handling used oil. Please dispose of used motor oil in a manner that is compatible with the environment. We suggest you take it in a sealed container to your local service station or recycling center for reclamation. Do not throw it in the trash, pour it on the ground, or down a drain.

---

# 10,000W Generator

---

## Maintenance

### Air Cleaner Service

A dirty air cleaner will restrict air flow to the carburetor. To prevent carburetor malfunction, service the air cleaner regularly. Service more frequently when operation the generator in extremely dusty areas.



#### NOTE

Never run the generator without the air filter. Engine will wear down.

1. Unsnap the air cleaner cover clips, remove the air cleaner cover, and remove the element.
2. Wash the air cleaner element in a solution of household detergent and warm water, then rinse thoroughly, or wash in nonflammable or high flashpoint solvent. Allow the air cleaner element to dry thoroughly.
3. Reinstall the air cleaner element and the cover.

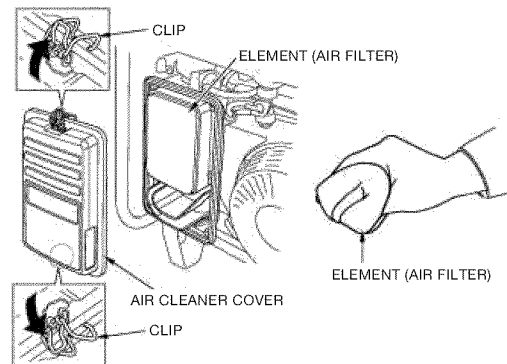

### Fuel Sediment Cup Cleaning

The sediment cup prevents dirt and water which may be in the fuel tank from entering the carburetor. If the engine has not been run for a long time, the sediment cup should be cleaned.

1. Turn the fuel valve lever to the OFF position. Remove the sediment cup, O-ring, and filter.
2. Clean the sediment cup, O-ring, and filter in nonflammable or high flash point solvent.
3. Reinstall the filter, O-ring, and sediment cup.
4. Turn the fuel valve lever ON and check for leaks.

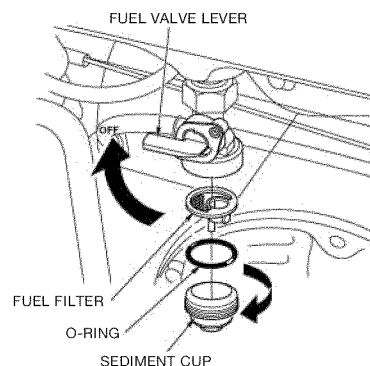

---

# Owner's Manual

---

## Maintenance

### Spark Plug Service

In order to service the spark plug, you will need a spark plug wrench (commercially available).

Recommended spark plugs: NHSP LD F7TC or Champion N9YC

To ensure proper engine operation, the spark plug must be properly gapped and free of debris deposits.



#### WARNING

If the engine has been running, the muffler will be very hot. Be careful not to touch the muffler.

1. Remove the spark plug cap.
2. Clean any dirt from around the spark plug base.
3. Use a spark plug wrench to remove the spark plug.
4. Visually inspect the spark plug. Discard it if the insulator is cracked or chipped. Clean the spark plug with a wire brush if it is to be reused.
5. Measure the plug gap with a feeler gauge. Correct as necessary by carefully bending the side electrode.

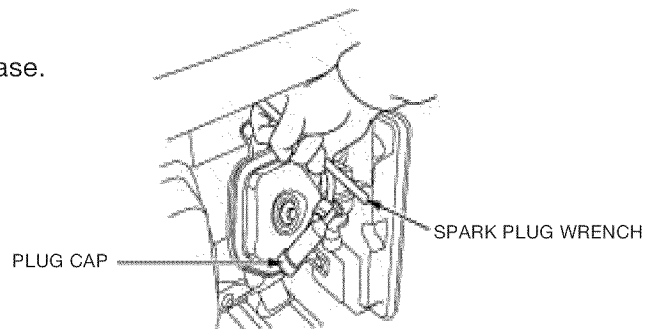

The gap should be: 0.70-0.80 mm (0.028-0.031 in)

6. Check that the spark plug washer is in good condition, and thread the spark plug in by hand to prevent cross-threading.
  7. After the spark plug is seated, tighten with a spark plug wrench to compress the washer.
- If installing a new spark plug, tighten 1/2 turn after the spark plug seats to compress the washer. If reinstalling a used spark plug, tighten 1/8-1/4 turn after the spark plug seats to compress the washer.

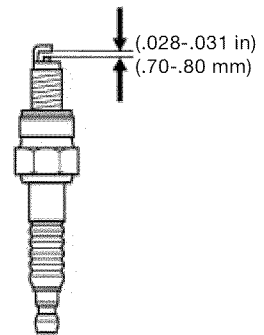

#### NOTE

The spark plug must be securely tightened. An improperly tightened spark plug can become very hot and could damage the engine. Never use spark plugs which have an improper heat range. Use only the recommended spark plugs or equivalent.

---

# 10,000W Generator

---

## Maintenance

### Spark Arrester Maintenance

If the generator has been running, the muffler will be very hot. Allow it to cool before proceeding.



The spark arrester must be serviced every 100 hours to maintain its efficiency.

### Clean the spark arrester as follows:

1. Loosen the screw by the exhaust port of the muffler and remove the spark arrester.
2. Use a brush to remove carbon deposits from the spark arrester screen.  
Inspect the screen for breaks or tears and replace it if necessary.
3. Install the spark arrester in the reverse order of removal.



---

# Owner's Manual

---

## Transporting/Storage

When transporting the generator, turn the engine switch and the fuel valve OFF. Keep the generator level to prevent fuel spillage. Fuel vapor or spilled fuel may ignite.



### WARNING

Contact with a hot engine or exhaust system can cause serious burns or fires. Let the engine cool before transporting or storing the generator.

Do not place heavy objects on the generator.

### Before storing the unit for an extended period:

1. Be sure the storage area is free of excessive humidity and dust.
2. Service according to the table below:

Storage time	Recommended service procedure to prevent hard starting
Less than 1 month	No preparation required
1 to 2 months	Fill with fresh gasoline and add gasoline conditioner*. (Fuel stabilizer)
2 months to 1 year	Fill with fresh gasoline and add gasoline conditioner*. (Fuel stabilizer) Drain the carburetor float bowl.
1 year or more	Fill with fresh gasoline and add gasoline conditioner*. (Fuel stabilizer) Remove the spark plug. Put a tablespoon of engine oil into the cylinder. Turn the engine slowly with the pull rope to distribute the oil. Reinstall the spark plug. Change the engine oil. After removal from storage, drain the stored gasoline into a suitable container, and fill with fresh gasoline before starting.

\*Use gasoline conditioners (fuel stabilizer) that are formulated to extend storage life.  
Contact your authorized generator dealer for conditioner recommendations.

---

# 10,000W Generator

---

## Assembly

### Battery Installation

1. Remove the cover under the panel as shown.

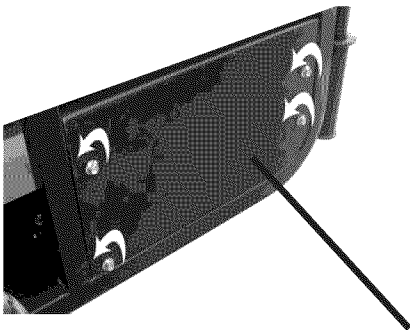

Cover

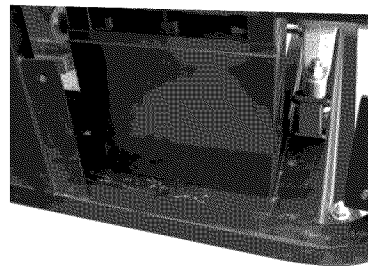

Connect battery and put in the cabin

2. Screw on one bolt to rivet the battery and screw the bolts to close up the plate as shown below.

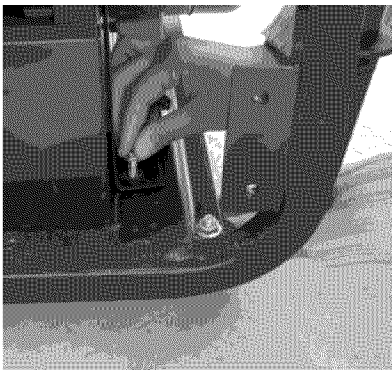

Rivet battery

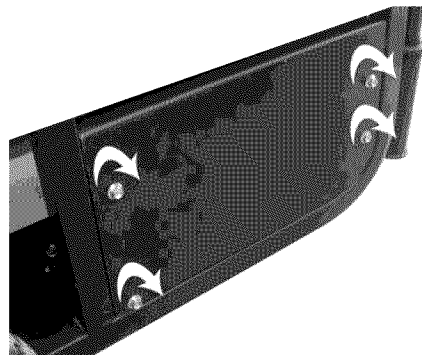

Close up the plate

---

# Owner's Manual

---

## Assembly

### Generator Assembly

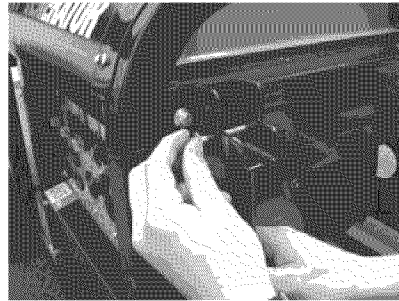
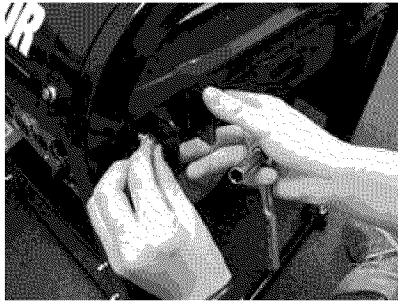

Start by installing the handle on the frame with two bolts supplied.



Place a block of wood under the generator so that you don't have to hold it up while trying to install the leg. Place the support leg under the frame. Push the bolt thru the frame and thru the leg. Thread a nut onto the bolt. Tighten with a wrench.

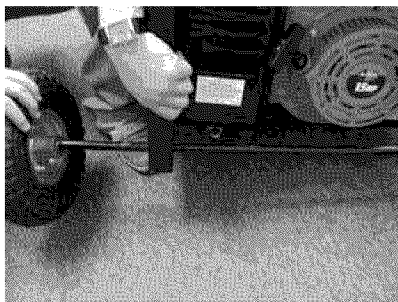

The wheels should be installed on the side opposite to the handle. Push the axle through the holes on the generator frame. Slide the wheels on each side.

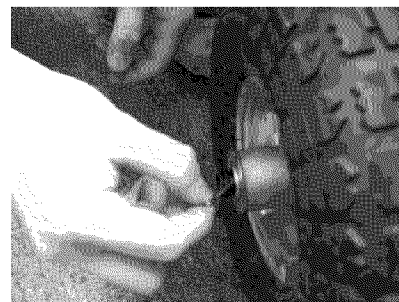

Push the cotter pin thru the axle and bend it backwards as shown.

---

# 10,000W Generator

---

## Compliance

UNITED STATES ENVIRONMENTAL PROTECTION AGENCY,  
WASHINGTON, DC 20460

2007 Model Year Certificate of Conformity

- **Manufacturer:** Chongqing Dajiang Power Equipment Co. Ltd.
- **Certificate Number:** CDP-NRSI-07-01
- **Effective Date:** 5/31/2006
- **Date Issued:** 5/31/2006

Merrylin Zaw-Mon, Director, Compliance and Innovation Strategies Division, Office of Transportation and Air Quality.

Pursuant to Section 213 of Clean Air Act (42 U.S.C. section 7547) and 40 CFR 90, and subject to the terms and conditions prescribed in those provisions, this certificate of conformity is hereby issued for the following small non-road engine family, more fully described in the documentation required by 40 CFR 90 and produced in the stated model year.

This certificate of conformity covers only those new small non-road engines which conform in all material respects to the design specifications described in the documentation required by 40 CFR 90 and which are produced during the model year stated on this certificate. This certificate of conformity does not cover small non-road engines imported prior to the effective date of the certificate. SMALL NON-ROAD ENGINE FAMILY: 6CDPS

This certificate of conformity is conditional upon compliance of said manufacturer with the averaging, banking, and trading provisions of 40 CFR Part 90, Subpart C both during and after model year production. Failure to comply with these provisions may render this certificate void ab initio. The HC + NOX family emission limit (FEL) is: g/k W-hr.

It is a term of this certificate that the manufacturer shall consent to all inspections described in 40 CFR 90.126 and 90.506 and authorized in a warrant or court order. Failure to comply with the requirements of such a warrant or court order may lead to revocation or suspension of this certificate for reasons specified in 40 CFR 90. It is also a term of this certificate that this certificate may be revoked or suspended or rendered void ab initio for other reasons specified in 40 CFR 90.

This certificate does not cover small non-road engines sold, offered for sale, or introduced, or delivered for introduction, into commerce in the U.S. prior to the effective date of the certificate.



---

# Owner's Manual

---

## Specifications

### AC electrical

---

Current Output	120V/240V AC @ 62/31A 60Hz
Continuous/rated Wattage	7,500 WATTS
Peak Wattage	10,000 WATTS
Outlet	(4) 120V AC, 3 spring grounded (2) 120/240V AC twist-lock outlet

---

### DC electrical

---

12V	8.3 A
-----	-------

---

### Gasoline engine

---

Horsepower	15
Type	4-cycle OHV air-cooled recoil start & electric start
Displacement	420cc
Oil capacity	1.16 quart (1.1 liter)
EPA approved	yes
Noise level	77 dB

---

### Fuel

---

Type	Unleaded gasoline
Capacity	8 gallons (30 L)
Running time	hours (approx.)
Fuel gauge	included

---

### Weight

---

Approximate weight	253 lbs.
--------------------	----------

---