

IMAGE[®] IO.O

Model No. IMTL39520

Serial No. _____

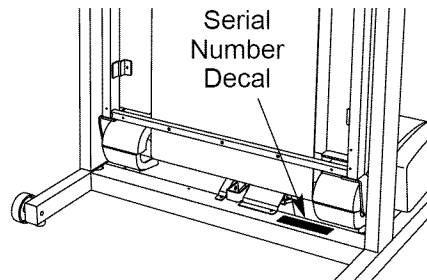

USER'S MANUAL

QUESTIONS?

If you have questions, or if there are missing or damaged parts, we will guarantee complete satisfaction through direct assistance from our factory.

TO AVOID DELAYS, PLEASE CALL DIRECT TO OUR TOLL-FREE CUSTOMER HOT LINE. The trained technicians on our Customer Hot Line will provide immediate assistance, free of charge to you.

CUSTOMER HOT LINE:
1-800-999-3756
Mon.-Fri., 6 a.m.-6 p.m. MST

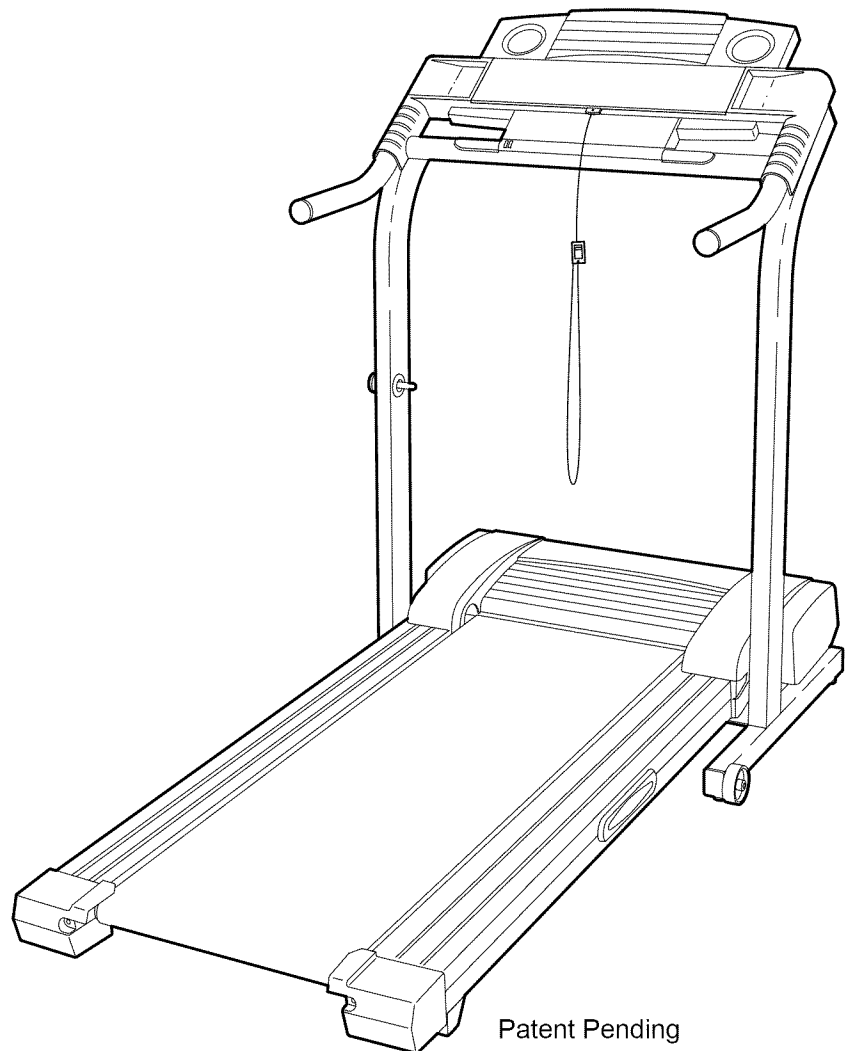

CAUTION

Read all precautions and instructions in this manual before using this equipment. Save this manual for future reference.



Visit our website at

www.imagefitness.com

*new products, prizes,
fitness tips, and much more!*

IMAGE[®] IO.O

TABLE OF CONTENTS

IMPORTANT PRECAUTIONS	3
BEFORE YOU BEGIN	5
ASSEMBLY	6
OPERATION AND ADJUSTMENT	9
HOW TO FOLD AND MOVE THE TREADMILL	20
TROUBLESHOOTING	22
CONDITIONING GUIDELINES	24
PART LIST	27
ORDERING REPLACEMENT PARTS	Back Cover
LIMITED WARRANTY	Back Cover

Note: An EXPLODED DRAWING and a PART LIST are attached in the center of this manual.

IMPORTANT PRECAUTIONS

⚠️ WARNING: To reduce the risk of burns, fire, electric shock, or injury to persons, read the following important precautions and information before operating the treadmill.

1. It is the responsibility of the owner to ensure that all users of this treadmill are adequately informed of all warnings and precautions.
2. Use the treadmill only as described.
3. Place the treadmill on a level surface, with at least eight feet of clearance behind it and two feet on each side. Do not place the treadmill on any surface that blocks air openings. To protect the floor or carpet from damage, place a mat under the treadmill.
4. Keep the treadmill indoors, away from moisture and dust. Do not put the treadmill in a garage or covered patio, or near water.
5. Do not operate the treadmill where aerosol products are used or where oxygen is being administered.
6. Keep children under the age of 12 and pets away from the treadmill at all times.
7. The treadmill should not be used by persons weighing more than 250 pounds.
8. Never allow more than one person on the treadmill at a time.
9. Wear appropriate exercise clothes when using the treadmill. Do not wear loose clothes that could become caught in the treadmill. Athletic support clothes are recommended for both men and women. *Always wear athletic shoes. Never use the treadmill with bare feet, wearing only stockings, or in sandals.*
10. When connecting the power cord (see page 9), plug the power cord into a surge suppressor (not included) and plug the surge suppressor into a grounded circuit capable of carrying 15 or more amps. No other appliance should be on the same circuit. Do not use an extension cord.
11. Use only a single-outlet surge suppressor that meets all of the specifications described on page 9. To purchase a surge suppressor, see your local IMAGE dealer or call 1-800-806-3651 and order part number 146148.
12. Failure to use a properly functioning surge suppressor could result in damage to the control system of the treadmill. If the control system is damaged, the walking belt may change speed or stop unexpectedly, which may result in a fall and serious injury.
13. Keep the power cord and the surge suppressor away from heated surfaces.
14. Never move the walking belt while the power is turned off. Do not operate the treadmill if the power cord or plug is damaged, or if the treadmill is not working properly. (See **BEFORE YOU BEGIN** on page 5 if the treadmill is not working properly.)
15. Never start the treadmill while you are standing on the walking belt. Always hold the handrails while using the treadmill.
16. The treadmill is capable of high speeds. Adjust the speed in small increments to avoid sudden jumps in speed.
17. The pulse sensor is not a medical device. Various factors, including the user's movement, may affect the accuracy of heart rate readings. The pulse sensor is intended only as an exercise aid in determining heart rate trends in general.
18. Never leave the treadmill unattended while it is running. Always remove the key, and unplug the power cord when the treadmill is not in use.
19. Do not attempt to raise, lower, or move the treadmill until it is properly assembled. (See **ASSEMBLY** on page 6, and **HOW TO FOLD AND MOVE THE TREADMILL** on page 20.) You must be able to safely lift 45 pounds (20 kg) in order to raise, lower, or move the treadmill.
20. Do not change the incline of the treadmill by placing objects under the treadmill.
21. When folding or moving the treadmill, make sure that the storage latch is fully closed.

22. When using iFIT.com CDs and videos, an electronic “chirping” sound will alert you when the speed of the treadmill is about to change. Always listen for the “chirp” and be prepared for speed changes. In some instances, the speed may change before the personal trainer describes the change.

23. When using iFIT.com CDs and videos, you can manually override the speed setting at any time by pressing the speed buttons. However, when the next “chirp” is heard, the speed will change to the next settings for the CD or video program.

24. Always remove iFIT.com CDs and videos from your CD player or VCR when you are not using them.

25. Inspect and properly tighten all parts of the

treadmill regularly.

26. Never insert or drop any object into any opening.

27. **DANGER:** Always unplug the power cord immediately after use, before cleaning the treadmill, and before performing the maintenance and adjustment procedures described in this manual. Never remove the motor hood unless instructed to do so by an authorized service representative. Servicing other than the procedures in this manual should be performed by an authorized service representative only.

28. This treadmill is intended for in-home use only. Do not use this treadmill in any commercial, rental, or institutional setting.

⚠WARNING: Before beginning this or any exercise program, consult your physician. This is especially important for persons over the age of 35 or persons with pre-existing health problems. Read all instructions before using. ICON assumes no responsibility for personal injury or property damage sustained by or through the use of this product.

SAVE THESE INSTRUCTIONS

The decals shown have been placed on your treadmill. If a decal is missing, or if it is not legible, please call our Customer Service Department, toll-free, to order a free replacement decal (see the front cover of this manual). Apply the decal in the location shown. Note: The decals are not all shown at actual size.

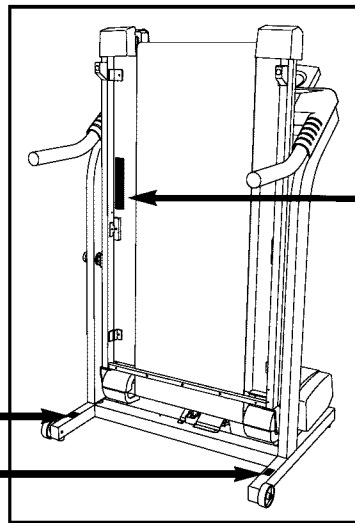
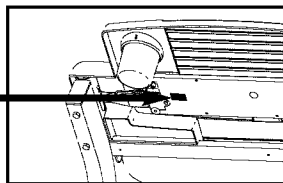
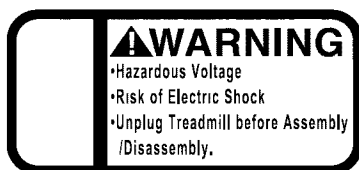

⚠WARNING:
Protect yourself and others from risk of serious injury. Read the user's manual and

- Stand only on the side rails when starting or stopping treadmill
- Change speed in small increments
- Hold handrails to prevent falling, and always wear the safety clip while operating treadmill
- Stop if you feel faint, dizzy or short of breath
- Fully engage storage latch before treadmill is moved or stored
- Reduce incline to its lowest level before folding treadmill into storage position
- Never allow children on or around treadmill.
- Remove key when not in use.
- Keep clothing, fingers and hair away from moving belt
- Never try to adjust or fix the belt while it is moving
- Always wear athletic shoes while operating treadmill.

BEFORE YOU BEGIN

Thank you for selecting the new IMAGE® 10.0 treadmill. The 10.0 treadmill combines advanced technology with innovative design to help you get the most from your exercise program in the convenience of your home. And when you're not exercising, the unique 10.0 can be folded up, requiring less than half the floor space of other treadmills.



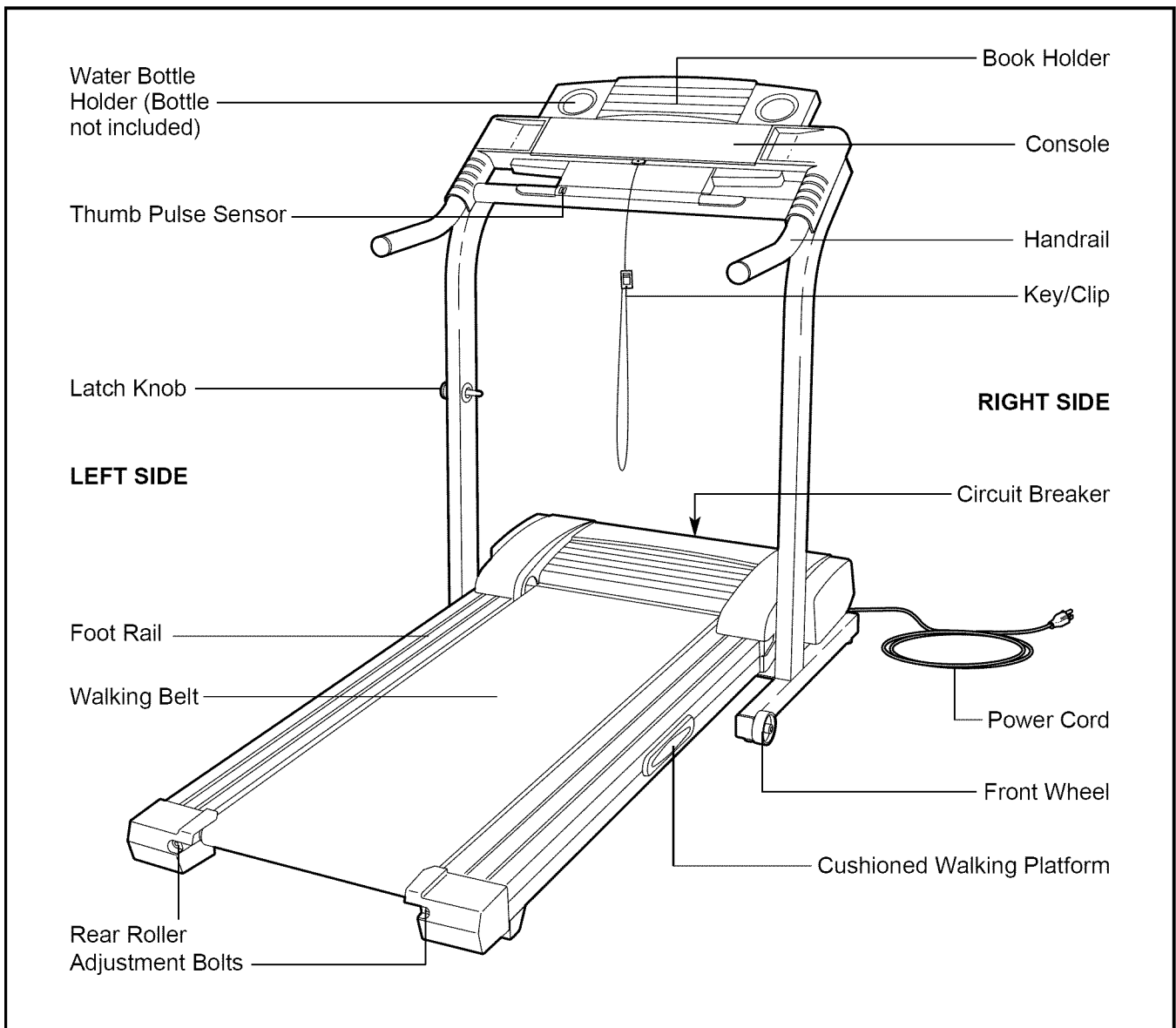

For your benefit, read this manual carefully before using the treadmill. If you have questions after reading this manual, please call our Customer Service

Department toll-free at 1-800-999-3756, Monday through Friday, 6 a.m. until 6 p.m. Mountain Time (excluding holidays). To help us assist you, please note the product model number and serial number before calling. The model number of the treadmill is IMTL39520. The serial number can be found on a decal attached to the treadmill (see the front cover of this manual for the location).

Before reading further, please review the drawing below and familiarize yourself with the labeled parts.

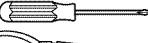

ASSEMBLY

Assembly requires two persons. Set the treadmill in a cleared area and remove all packing materials. Do not dispose of the packing materials until assembly is completed. **Assembly requires your own Phillips screwdriver** , **adjustable wrench** , **wire cutters** , and **needlenose pliers** .

Note: The underside of the treadmill walking belt is coated with high-performance lubricant. During shipping, a small amount of lubricant may be transferred to the top of the walking belt or the shipping carton. This is a normal condition and does not affect treadmill performance. If there is lubricant on top of the walking belt, simply wipe off the lubricant with a soft cloth and a mild, non-abrasive cleaner.

To identify small parts during assembly, use the part identification drawings below.

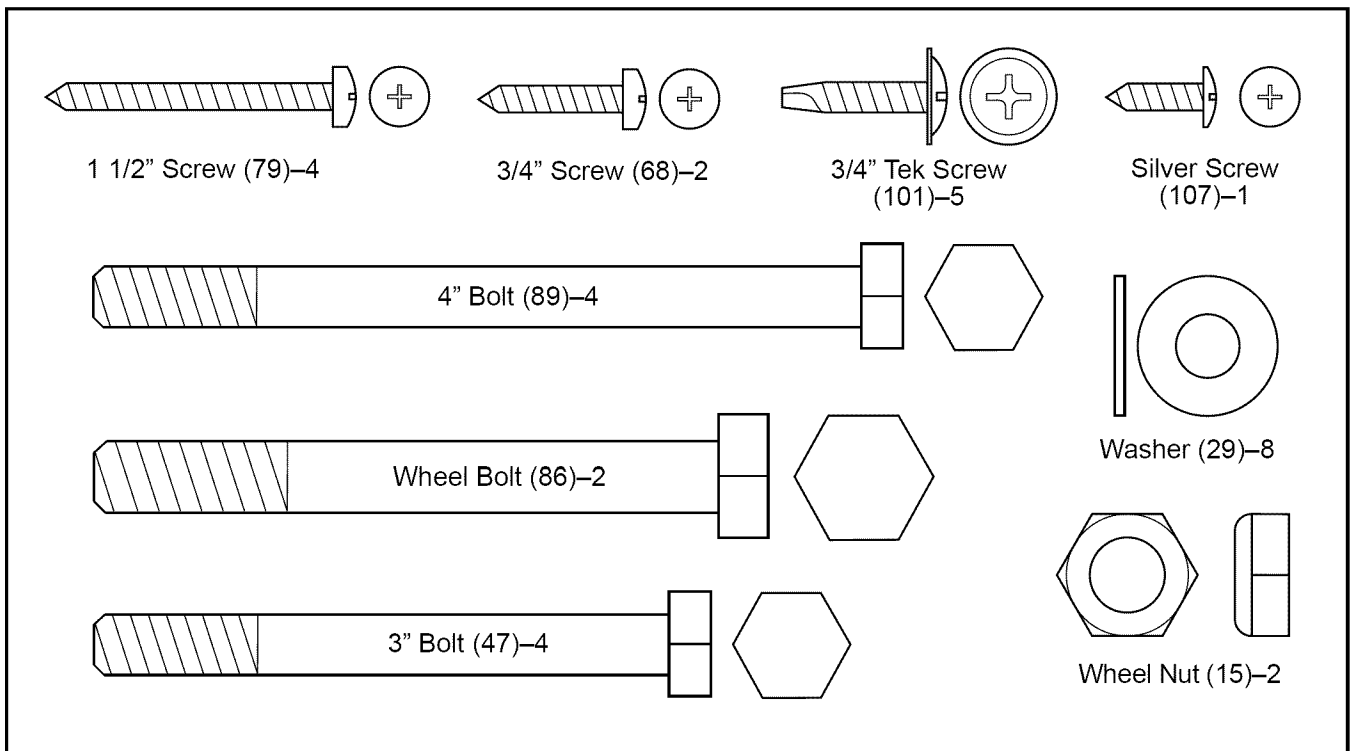

1. Make sure that the power cord is not plugged in.

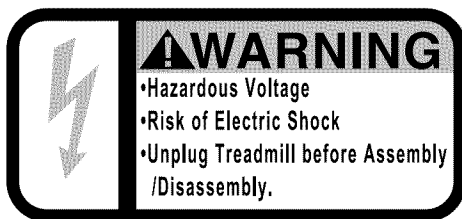

With the help of a second person, carefully tip the treadmill onto its left side. Partially fold the Frame (12) so that the treadmill will be more stable. **Do not fully fold the treadmill until it is completely assembled.**

Attach two Base Pads (97) to the bottom of the Base (82) with two 3/4" Tek Screws (101). Attach a Wheel (95) to the outside of the Base with a Wheel Bolt (86) and a Wheel Nut (15).

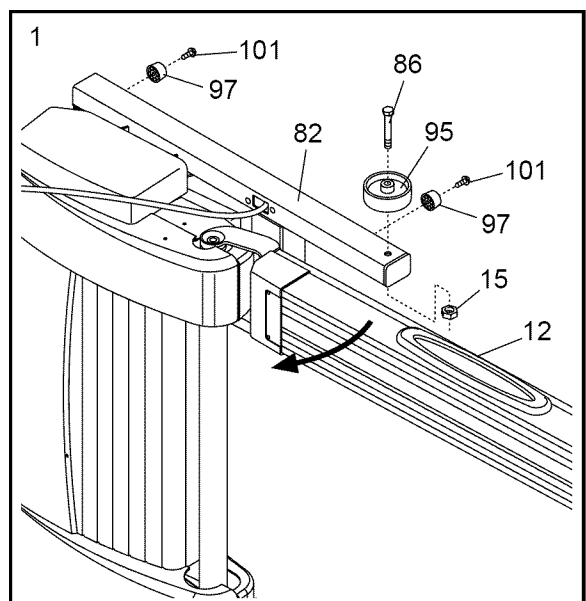

- Identify the Right Upright (10), which has a large rectangular hole near the upper end (see drawing 2b). Have a second person hold the Right Upright near the Wire Harness (17). Insert the end of the Wire Harness into the Right Upright and out of the rectangular hole near the upper end as shown. If necessary, use needlenose pliers to pull the Wire Harness out of the hole.

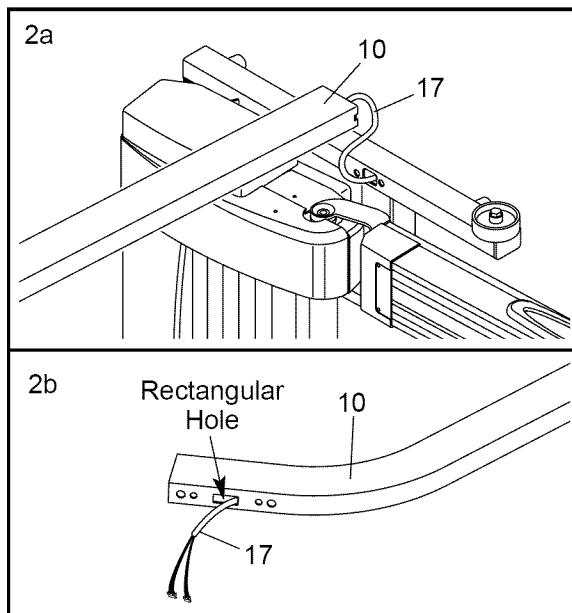

- Make sure that the Right Upright (10) is turned so it bends in the direction shown. Insert two 3" Bolts (47) with Washers (29) through the Base (82) and **hand tighten** the Bolts into the lower end of the Right Upright.

With the help of a second person, tip the treadmill onto its other side and repeat steps 1 through 3. Note: There is not a wire harness in the Left Upright (not shown). An extra Base Pad may be included.

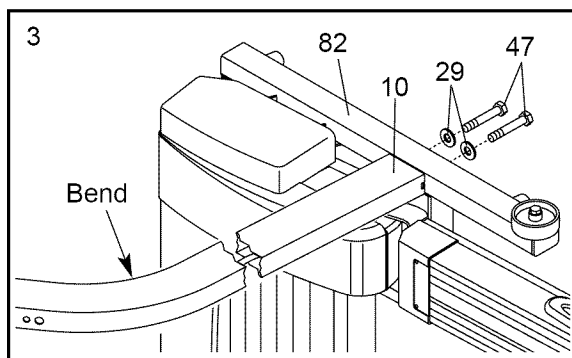

- With the help of a second person, set the treadmill flat on the floor so that the Right Upright (10) and the Left Upright (not shown) are vertical.

Hold one of the Handrails (85) near the Right Upright (10). Insert the end of the Wire Harness (17) into the bottom of the Handrail and out of the indicated hole. Using the Silver Screw (107), attach the end of the ground wire to the small hole in the side of the Handrail.

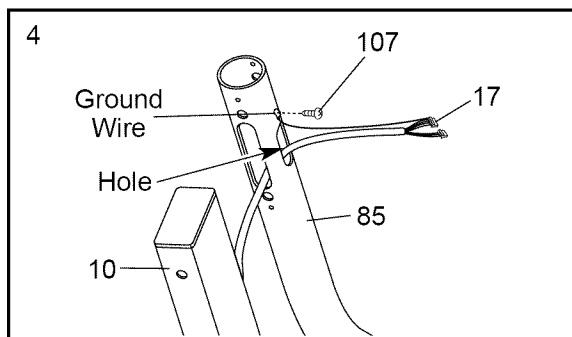

- Have a second person hold the Console Base (87) and the Handrail (85) in the position shown. **Touch the Right Upright (10) to discharge any static.** Insert the Wire Harness (17) through the two Plastic Ties (108) on the Console Base. Find the 3-wire connector on the end of the Wire Harness. Insert the connector into the red socket beneath the Console Base. **The connector should slide easily into the socket and "snap" into place.** If the connector does not slide easily and snap into place, turn the connector and then insert it. **If the connectors are not inserted properly, the Console may be damaged when the power is turned on.**

Insert the 5-wire connector into the black socket beneath the Console in the same way. Make sure that the connectors and wires appear as shown in the inset drawing. Insert the excess Wire Harness (17) down through the Handrail.

Securely tighten the Plastic Ties (108) to prevent the Wire Harness (17) from slipping. Then, cut off the ends of the Plastic Ties.

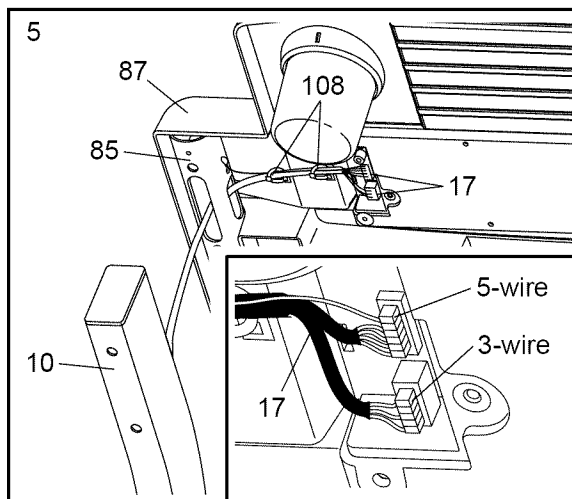

- Attach the Handrail (85) to the Console Base (87) with two 1 1/2" Screws (79) as shown. Attach the other Handrail (not shown) to the other side of the Console Base in the same way.

Insert the excess Wire Harness (17) down into the Right Upright (10) as you set the right Handrail (85) on the Right Upright. **Hand tighten** two 4" Bolts (89) with Washers (29) through the Right Upright into the right Handrail. **Be careful not to pinch the Wire Harness. Do not tighten the Bolts yet.**

Attach the left Handrail to the Left Upright (not shown) in the same way. Note: There is not a wire harness in the Left Upright.

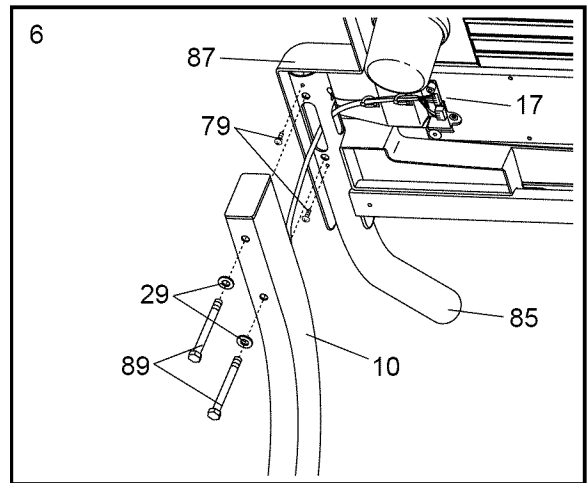

- Hold the Connector Cover (110) on the Console Base (87) in the position shown. Attach the Connector Cover to the Console Base with two 3/4" Screws (68).

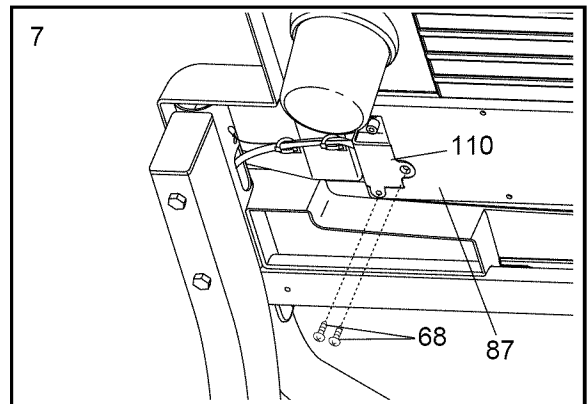

- Remove the Lock Knob (105) from the Lock Pin (11). Make sure that the Lock Pin Collar (14) and the Spring (56) are on the Lock Pin as shown. Insert the Lock Pin into the Storage Latch (77) and tighten the Lock Knob onto the Lock Pin.

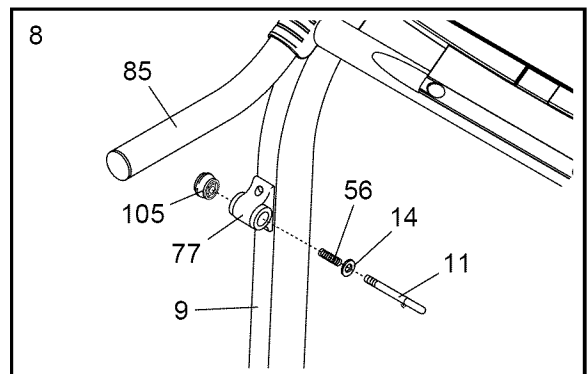

- Lower the Uprights (9, 10) until the Handrails (not shown) are touching the floor. Make sure that the treadmill Frame (12) is centered between the Uprights. Refer to step 3. Firmly tighten the four 3" Bolts (47). Refer to step 6. Firmly tighten the four 4" Bolts (89). Raise the Uprights back to the vertical position.

Make sure the two Cup Holders (118) are pressed into the round holes on top of the Console Base (87).

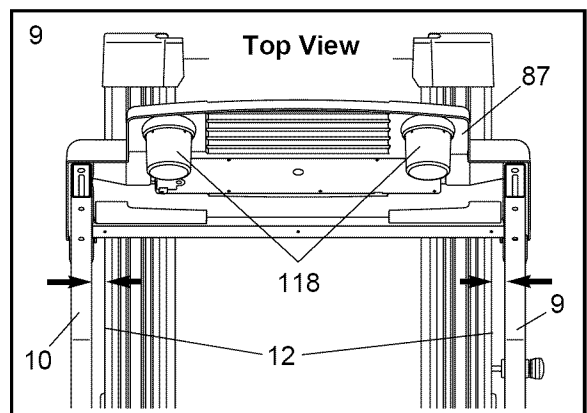

- Make sure that all parts are properly tightened before you use the treadmill.** Note: Extra hardware may be included. Keep the included allen wrench in a secure place; the allen wrench is used to adjust the walking belt (see page 23). To protect the floor or carpet from damage, place a mat under the treadmill.

OPERATION AND ADJUSTMENT

THE PERFORMANT LUBE™ WALKING BELT

Your treadmill features a walking belt coated with PERFORMANT LUBE™, a high-performance lubricant. **IMPORTANT: Never apply silicone spray or other substances to the walking belt or the walking platform. Such substances will deteriorate the walking belt and cause excessive wear.**

HOW TO PLUG IN THE POWER CORD

⚠ DANGER: Improper connection of the equipment-grounding conductor can result in an increased risk of electric shock. Check with a qualified electrician or serviceman if you are in doubt as to whether the product is properly grounded. Do not modify the plug provided with the product—if it will not fit the outlet, have a proper outlet installed by a qualified electrician.

Your treadmill, like any other type of sophisticated electronic equipment, can be seriously damaged by sudden voltage changes in your home's power. Voltage surges, spikes, and noise interference can result from weather conditions or from other appliances being turned on or off. **To decrease the possibility of your treadmill being damaged, always use a surge suppressor with your treadmill (see drawing 1 at the right). To purchase a surge suppressor, see your local IMAGE dealer or call 1-800-806-3651 and order part number 146148.**

Use only a single-outlet surge suppressor that is UL 1449 listed as a transient voltage surge suppressor (TVSS). The surge suppressor must have a UL suppressed voltage rating of 400 volts or less and a minimum surge dissipation of 450 joules. The surge suppressor must be electrically rated for 120 volts AC and 15 amps. There must be a monitoring light on the surge suppressor to indicate whether it is functioning properly. Failure to use a properly functioning surge suppressor could result in damage to the control system of the treadmill. If the control system is damaged, the walking belt may change speed or stop unexpectedly, which may result in a fall and serious injury.

This product must be grounded. If it should malfunction or break down, grounding provides a path of least resistance for electric current to reduce the risk of electric shock. This product is equipped with a cord having

an equipment-grounding conductor and a grounding plug. **Plug the power cord into a surge suppressor, and plug the surge suppressor into an appropriate outlet that is properly installed and grounded in accordance with all local codes and ordinances. Important: The treadmill is not compatible with GFCI-equipped outlets.**

This product is for use on a nominal 120-volt circuit, and has a grounding plug that looks like the plug illustrated in drawing 1 below. A temporary adapter that looks like the adapter illustrated in drawing 2 may be used to connect the surge suppressor to a 2-pole receptacle as shown in drawing 2 if a properly grounded outlet is not available.

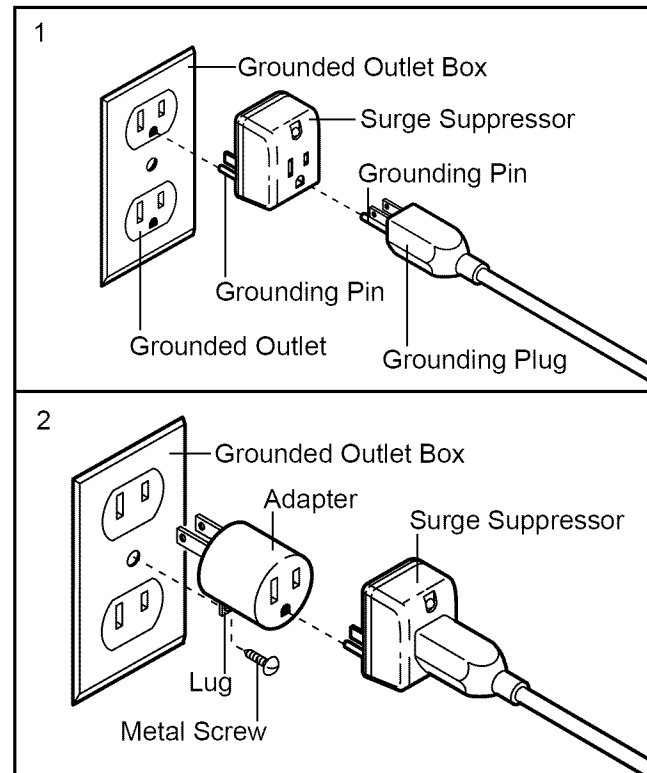

The temporary adapter should be used only until a properly grounded outlet (drawing 1) can be installed by a qualified electrician.

The green-colored rigid ear, lug, or the like extending from the adapter must be connected to a permanent ground such as a properly grounded outlet box cover. Whenever the adapter is used it must be held in place by a metal screw. **Some 2-pole receptacle outlet box covers are not grounded. Contact a qualified electrician to determine if the outlet box cover is grounded before using an adapter.**

CONSOLE DIAGRAM

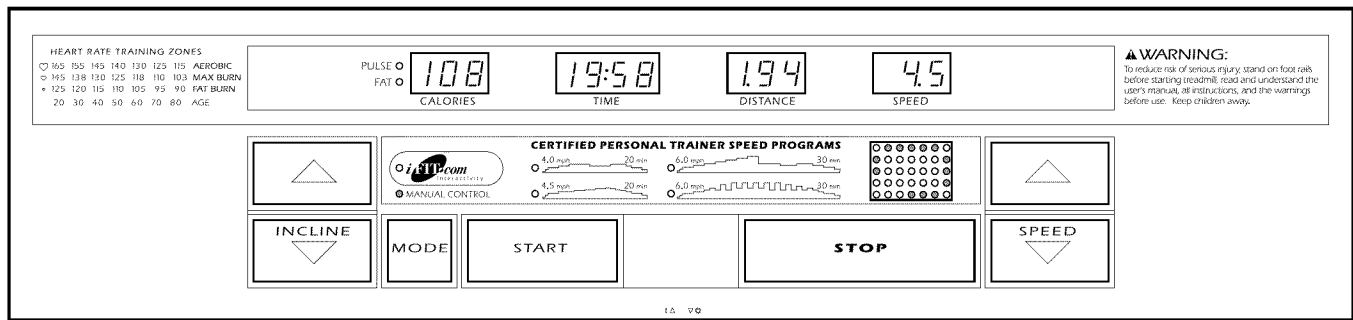

Note: If there is a thin sheet of plastic on the console, remove it.

Key

Clip

CAUTION: Before operating the console, read the following precautions.

- Do not stand on the walking belt when turning on the power.
- Always wear the clip (see the drawing above) while operating the treadmill.
- Adjust the speed in small increments to avoid sudden jumps in speed.
- To reduce the possibility of electric shock, keep the console dry. Avoid spilling liquids on the console and place only a sealed water bottle in the water bottle holder.

FEATURES OF THE CONSOLE

The console offers a selection of features designed to help you get the most from your exercise. When the manual mode of the console is selected, the speed and incline of the treadmill can be changed with a touch of a button. As you exercise, the console will display continuous exercise feedback. You can even measure your heart rate using the built-in pulse sensor.

Four certified personal trainer speed programs are also offered. Each program automatically controls the speed of the treadmill as it guides you through an effective workout.

The console also features iFIT.com interactive technology. iFIT.com technology is like having a personal trainer right in your home. Using the included audio cable, you can connect the treadmill to your home stereo, portable stereo, or computer and play special iFIT.com CD programs (iFIT.com CD's are available separately). iFIT.com CD programs automatically control the speed of the treadmill as a personal trainer guides you through every step of your workout. High-energy music provides added motivation. Each CD features two programs designed by certified personal trainers.

In addition, you can connect the treadmill to your VCR and TV and play iFIT.com video programs (videocassettes are available separately). Video programs offer the same benefits as iFIT.com CD programs, but add the excitement of working out with a class and an instructor—the hottest new trend at health clubs.

With the treadmill connected to your computer, you can also go to our Web site at www.iFIT.com and access programs directly from the internet. See www.iFIT.com for details.

To purchase iFIT.com CD's or videocassettes, call toll-free 1-800-735-0768.

To use the manual mode of the console, follow the steps beginning on page 11. To use a personal trainer speed program, see page 12. To use an iFIT.com CD or video program, see page 17. To use an iFIT.com program directly from our Web site, see page 18.

HOW TO TURN ON THE POWER

- 1** Plug in the power cord (see page 9).
- 2** Stand on the foot rails of the treadmill.
- 3** Find the clip attached to the key (see the drawing on page 10), and slide the clip onto the waistband of your clothes. Next, insert the key into the console. After a moment, the displays and various indicators will light. **Test the clip by carefully taking a few steps backward until the key is pulled from the console. If the key is not pulled from the console, adjust the position of the clip.**

HOW TO USE THE MANUAL MODE

- 1** Insert the key fully into the console.
See HOW TO TURN ON THE POWER above.
- 2** Select the manual mode.
When the key is inserted, the manual mode will be selected and the Manual Control indicator will light. If a program has been selected, press the Mode button repeatedly to reselect the manual mode.
- 3** Press the Start button or the Speed Δ button to start the walking belt.

A moment after the button is pressed, the walking belt will begin to move. Hold the handrails and begin walking. As you exercise, change the speed of the walking belt as desired by pressing the Speed buttons.

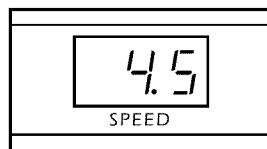

Each time a button is pressed, the speed setting will change by 0.1 mph; if a button is held down, the speed setting will change in increments of 0.5 mph. **Note: The console can display speed and distance in either miles or kilometers (see SPEED DISPLAY on page 12). For simplicity, all instructions in this section refer to miles.**

To stop the walking belt, press the Stop button. The Time display will begin to flash. To restart the walking belt, press the Start button or the Speed Δ button.

Note: The first time you use the treadmill, periodically inspect the alignment of the walking belt, and align it if necessary (see page 23).

- 4** Change the incline of the treadmill as desired.
To change the incline of the treadmill, press either of the Incline buttons until the desired incline level is reached.
- 5** Follow your progress with the LED track and the displays.

The LED Track—When the manual mode or the iFIT.com mode is selected, the LED display will show a track representing 1/4 mile. As you exercise, the indicators around the track will light in sequence until you have completed 1/4 mile. A new lap will then begin.

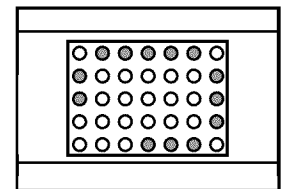

Calories/Fat Calories/Pulse display—This display shows the approximate numbers of *calories* and *fat calories* you have burned (see FAT BURNING on page 24). The display will change from one number to the other every few seconds. The FAT indicator will light when the number of fat calories is shown. The display will also show your heart rate when you use the pulse sensor (see step 6 on page 12).



Time display—When the manual mode or the iFIT.com mode is selected, this display will show the elapsed time. When a personal trainer program is selected, the display will show the time remaining in the program.

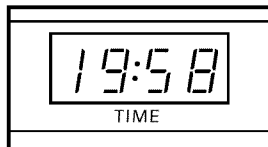

Distance display—This display shows the distance that you have walked or run.

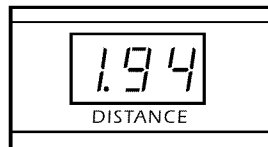

Speed display—This display shows the speed of the walking belt.

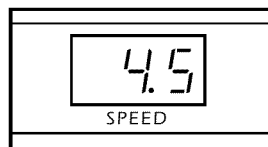

Note: The console can display speed and distance in either miles or kilometers. To see which unit of measurement is selected, hold down the Stop button, insert the key into the console, and continue to hold the Stop button for a few seconds. An “E” for English miles or an “M” for metric kilometers will appear in the display. Press the Speed Δ button to change the unit of measurement. When the desired unit of measurement is selected, remove the key and then reinsert it.

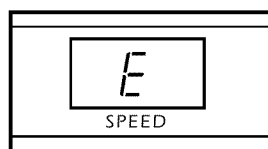

To reset the displays, press the Stop button, remove the key, and then reinsert the key.

6 Measure your heart rate, if desired.

To measure your heart rate, stand on the foot rails and place your thumb on the pulse sensor.

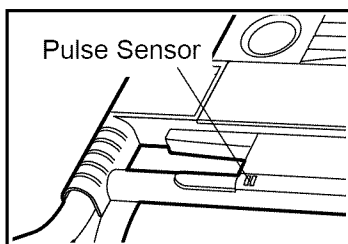

Do not press too hard, or the circulation in your thumb will be restricted and your pulse will not be detected. After a few seconds, the PULSE indicator beside the Calories/Fat Calories/Pulse display will light and then your heart rate will be shown. Hold your thumb on the pulse sensor for about 15 seconds for the most accurate reading.

If the displayed heart rate appears to be too high or too low, or if your heart rate is not displayed, lift your thumb off the pulse sensor for a few seconds. Then, place your thumb on the pulse sensor as described above. Remember to stand still while measuring your heart rate.

7 When you are finished exercising, remove the key.

Step onto the foot rails and press the Stop button. **Adjust the incline of the treadmill to the lowest setting.** Next, remove the key from the console and put it in a secure place.

HOW TO USE PERSONAL TRAINER PROGRAMS

1 Insert the key fully into the console.

See HOW TO TURN ON THE POWER on page 11.

2 Select a personal trainer program.

When the key is inserted, the manual mode will be selected. To select a personal trainer program, press the Mode button repeatedly until one of the four personal trainer program indicators lights.

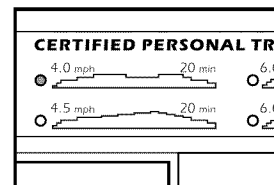

When a personal trainer program is selected, the Time display will show how long the program will last and the Speed display will flash the maximum speed setting for the program for a few seconds.

The profiles in the center of the console show how the speed of the treadmill will change during the programs. The first four speed settings for the selected program will be shown in the LED display.

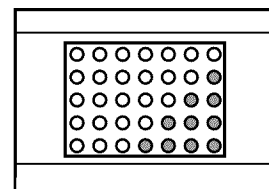

3 Press the Start button or the Speed Δ button to start the program.

A moment after the button is pressed, the treadmill will automatically adjust to the first speed setting for the program. Hold the handrails and begin walking.

Each program is divided into several time periods of different lengths. One speed setting is programmed for each period. (The same speed setting may be programmed for consecutive periods.) The speed setting for the first period will be shown in the flashing Current Period column of the LED display. The speed settings for the next four periods will be shown in the four columns to the right.

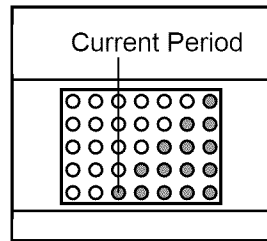

When only three seconds remain in the first period of the program, the Speed display will flash, the Current Period column and the column to the right will flash, and a series of tones will sound. When the first period is completed, *all speed settings will move one column to the left*. The speed setting for the second period will then be shown in the flashing Current Period column and the treadmill will automatically adjust to the speed setting for the second period. (When the same speed setting is programmed for consecutive periods, the Speed display will not flash and the column to the right of the Current Period column will not flash during the last three seconds of the current period.)

Note: If all of the indicators in the Current Period column are lit after the speed settings have moved to the left, *the speed settings will move downward so that only the highest indicators in the columns appear in the LED display*. If some indicators in the Current Period column are not lit after the speed settings have moved to the left again, the speed settings will move back up.

To change the incline of the treadmill during the program, press the Incline buttons until the desired incline level is reached.

The program will continue until the speed setting for the last period is shown in the Current Period column and no time remains in the Time display. The walking belt will then slow to a stop.

Note: If the speed setting for the current period is too high or too low, you can manually override the setting by pressing the Speed buttons. Every few times a button is pressed, an additional indicator will light or darken in the Current Period column. (If any of the columns to the right of the Current Period column have the same number of lit indicators as the Current Period column, an additional indicator may light or darken in those columns as well.) **Important: When the current period of the program ends, the treadmill will automatically adjust to the speed setting for the next period.**

To stop the program temporarily, press the Stop button. The Time display will begin to flash. To restart the program, press the Start button or the Speed Δ button. To end the program, press the Stop button, remove the key, and then reinsert the key.

4 Follow your progress with the displays.

See step 5 on page 11.

5 Measure your heart rate, if desired.

See step 6 on page 12.

6 When the program is completed, remove the key from the console.

When the program has ended, **adjust the incline of the treadmill to the lowest setting**. Next, remove the key from the console and put it in a safe place.

HOW TO CONNECT THE TREADMILL TO YOUR CD PLAYER, VCR, OR COMPUTER

To use **iFIT.com CD's**, the treadmill must be connected to your portable CD player, portable stereo, home stereo, or computer with CD player. See pages 14 and 15 for connecting instructions. To use **iFIT.com videocassettes**, the treadmill must be connected to your VCR. See page 16 for connecting instructions. To use **iFIT.com programs directly from our internet site**, the treadmill must be connected to your home computer. See page 15 for connecting instructions.

HOW TO CONNECT YOUR PORTABLE CD PLAYER

Note: If your CD player has separate **LINE OUT** and **PHONES** jacks, see instruction A below. If your CD player has only one jack, see instruction B.

- A. Plug one end of the audio cable into the jack beneath the console. Plug the other end of the cable into the **LINE OUT** jack on your CD player. Plug your headphones into the **PHONES** jack.

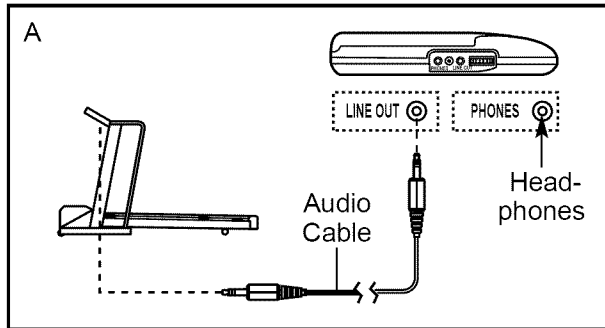

- B. Plug one end of the audio cable into the jack beneath the console. Plug the other end of the cable into a 3.5mm Y-adapter (available at electronics stores). Plug the Y-adapter into the **PHONES** jack on your CD player. Plug your headphones into the other side of the Y-adapter.

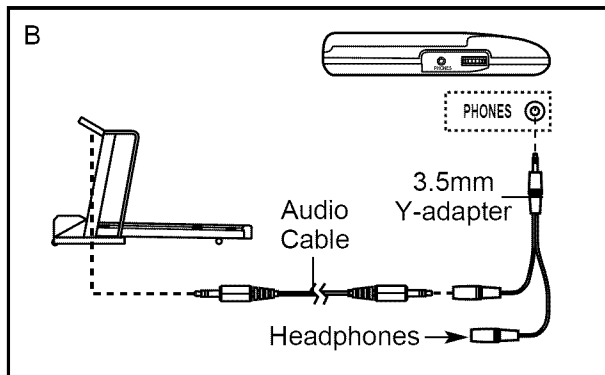

HOW TO CONNECT YOUR PORTABLE STEREO

Note: If your stereo has an **RCA-type AUDIO OUT** jack, see instruction A below. If your stereo has a **3.5mm LINE OUT** jack, see instruction B. If your stereo has only a **PHONES** jack, see instruction C.

- A. Plug one end of the audio cable into the jack beneath the console. Plug the other end of the cable into the included adapter. Plug the adapter into an **AUDIO OUT** jack on your stereo.

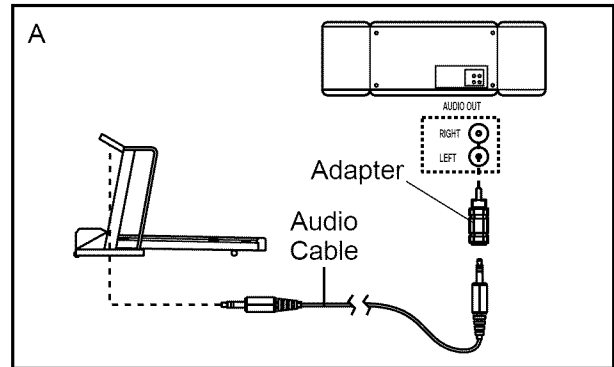

- B. Plug one end of the audio cable into the jack beneath the console. Plug the other end of the cable into the **LINE OUT** jack on your stereo.

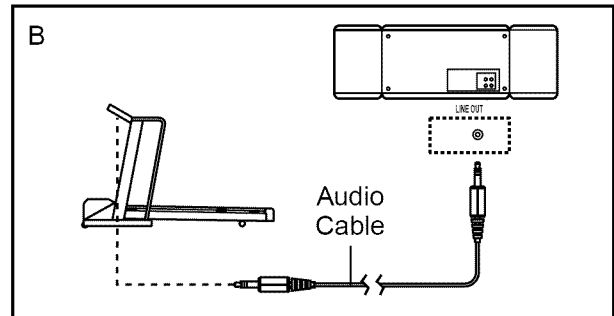

- C. Plug one end of the audio cable into the jack beneath the console. Plug the other end of the cable into a 3.5mm Y-adapter (available at electronics stores). Plug the Y-adapter into the **PHONES** jack on your stereo. Plug your headphones into the other side of the Y-adapter.

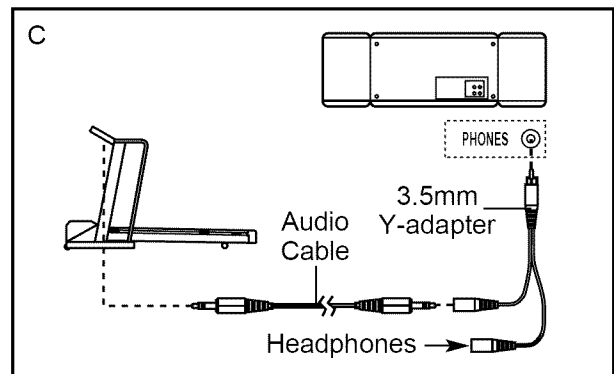

HOW TO CONNECT YOUR HOME STEREO

Note: If your stereo has an unused **LINE OUT** jack, see instruction **A** below. If the **LINE OUT** jack is being used, see instruction **B**.

- A. Plug one end of the audio cable into the jack beneath the console. Plug the other end of the cable into the included adapter. Plug the adapter into the **LINE OUT** jack on your stereo.

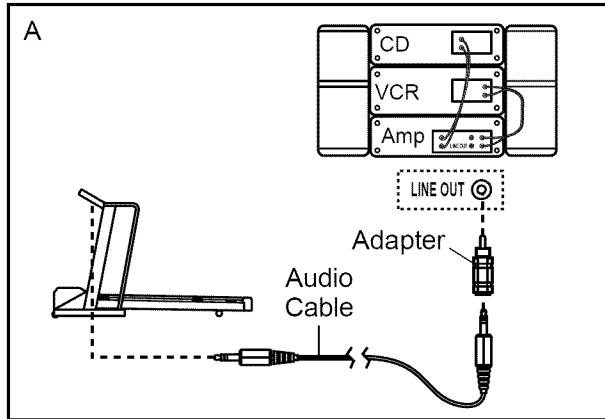

- B. Plug one end of the audio cable into the jack beneath the console. Plug the other end of the cable into the included adapter. Plug the adapter into an **RCA Y-adapter** (available at electronics stores). Next, remove the wire that is currently plugged into the **LINE OUT** jack on your stereo and plug the wire into the unused side of the Y-adapter. Plug the Y-adapter into the **LINE OUT** jack on your stereo.

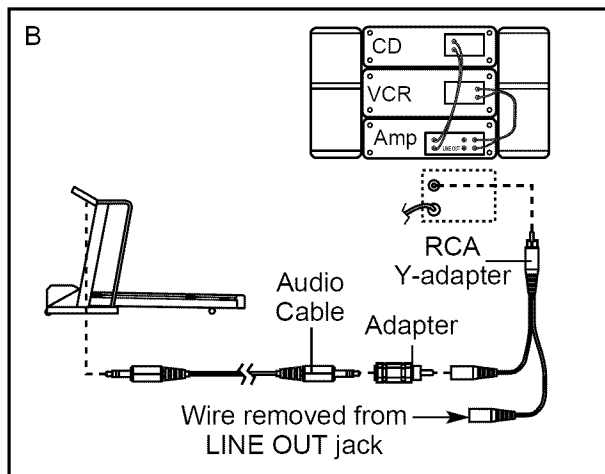

HOW TO CONNECT YOUR COMPUTER

Note: If your computer has a **3.5mm LINE OUT** jack, see instruction **A**. If your computer has only a **PHONES** jack, see instruction **B**.

- A. Plug one end of the audio cable into the jack beneath the console. Plug the other end of the cable into the **LINE OUT** jack on your computer.

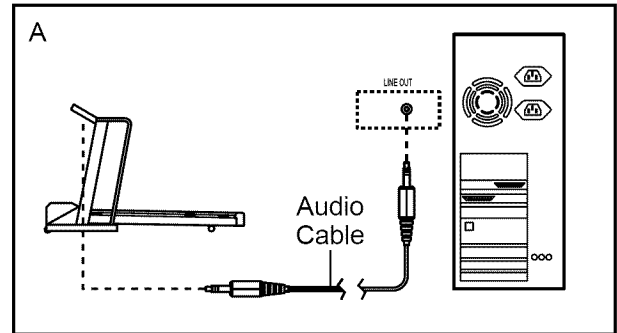

- B. Plug one end of the audio cable into the jack beneath the console. Plug the other end of the cable into a **3.5mm Y-adapter** (available at electronics stores). Plug the Y-adapter into the **PHONES** jack on your computer. Plug your headphones or speakers into the other side of the Y-adapter.

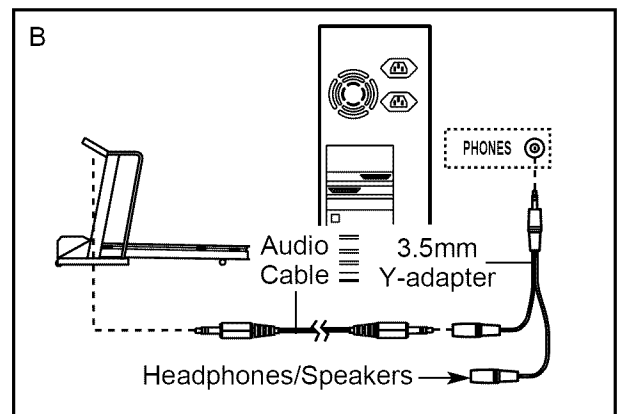

HOW TO CONNECT YOUR VCR

Note: If your VCR has an unused AUDIO OUT jack, see instruction A below. If the AUDIO OUT jack is being used, see instruction B. If you have a TV with a built-in VCR, see instruction B. If your VCR is connected to your home stereo, see HOW TO CONNECT YOUR HOME STEREO on page 15.

- A. Plug one end of the audio cable into the jack beneath the console. Plug the other end of the cable into the included adapter. Plug the adapter into the AUDIO OUT jack on your VCR.

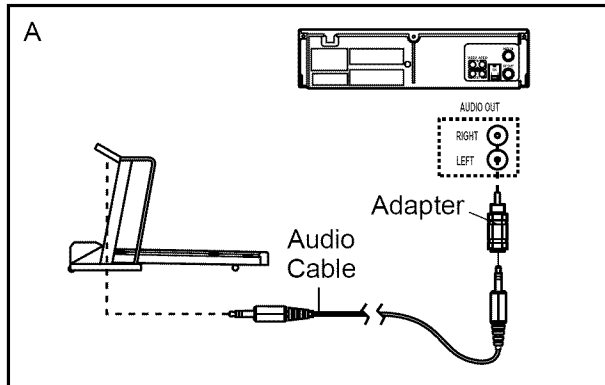

- B. Plug one end of the audio cable into the jack beneath the console. Plug the other end of the cable into the included adapter. Plug the adapter into an RCA Y-adapter (available at electronics stores). Next, remove the wire that is currently plugged into the AUDIO OUT jack on your VCR and plug the wire into the unused side of the Y-adapter. Plug the Y-adapter into the AUDIO OUT jack on your VCR.

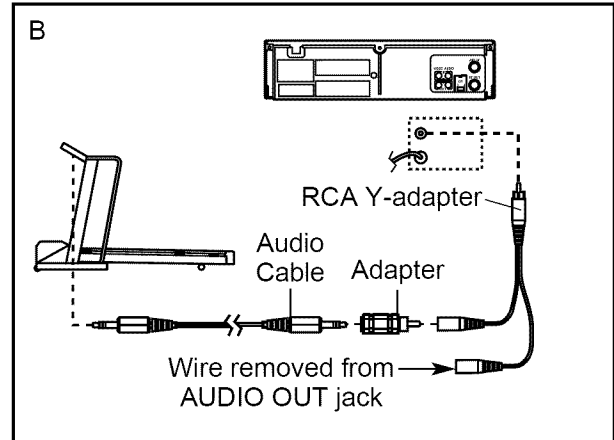

HOW TO USE iFIT.COM CD AND VIDEO PROGRAMS

To use iFIT.com CD's or videocassettes, the treadmill must be connected to your portable CD player, portable stereo, home stereo, computer with CD player, or VCR. See HOW TO CONNECT THE TREADMILL TO YOUR CD PLAYER, VCR, OR COMPUTER on page 14. **Note: iFIT.com CD and video programs will control only the speed of your treadmill.**

To purchase iFIT.com CD's or videocassettes, call toll-free 1-800-735-0768.

Follow the steps below to use an iFIT.com CD or video program.

1 Insert the key into the console.

See HOW TO TURN ON THE POWER on page 11.

2 Select the iFIT.com mode.

When the key is inserted, the manual mode will be selected. To use iFIT.com CD's or videocassettes, press the Mode button repeatedly until the iFIT.com indicator lights.



3 Insert the iFIT.com CD or videocassette.

If you are using an iFIT.com CD, insert the CD into your CD player. If you are using an iFIT.com videocassette, insert the videocassette into your VCR.

4 Press the PLAY button on your CD player or VCR.

A moment after the button is pressed, your personal trainer will begin guiding you through your workout. Simply follow your personal trainer's instructions. **Note:** If the Time display is flashing, press the Start button or the Speed Δ button on the console. The treadmill will not respond to a CD or video program when the Time display is flashing.

During the CD or video program, an electronic "chirping" sound will alert you when the speed of the treadmill is about to change. **CAUTION: Always listen for the "chirp" and be prepared for speed changes. In some instances, the speed may change before the personal trainer describes the change.**

If the speed setting is too high or too low, you can manually override the setting at any time by pressing the Speed buttons on the console. However, **when the next "chirp" is heard, the speed will change to the next setting of the CD or video program.**

To stop the walking belt at any time, press the Stop button on the console. The Time display will begin to flash. To restart the program, press the Start button or the Speed Δ button. After a moment, the walking belt will begin to move. **When the next "chirp" is heard, the speed will change to the next setting of the CD or video program.**

When the CD or video program is completed, the walking belt will stop and the Time display will begin to flash. **Note:** To use another CD or video program, press the Stop button or remove the key and go to step 1.

Note: If the speed of the treadmill does not change when a "chirp" is heard:

- Make sure that the iFIT.com indicator is lit and that the Time display is not flashing. If the Time display is flashing, press the Start button or the Speed Δ button on the console.
- Adjust the volume of your CD player or VCR. If the volume is too high or too low, the console may not detect the program signals.
- Make sure that the audio cable is properly connected, that it is fully plugged in, and that it is not wrapped around a power cord.

5 Follow your progress with the LED track and the displays.

See step 5 on page 11.

6 Measure your heart rate, if desired.

See step 6 on page 12.

7 When the program is completed, remove the key.

See step 6 on page 13.

CAUTION: Always remove iFIT.com CD's and videocassettes from your CD player or VCR when you are finished using them.

HOW TO USE PROGRAMS DIRECTLY FROM OUR WEB SITE

Our Web site at www.iFIT.com allows you to access programs directly from the internet. See www.iFIT.com for details. **Note: Programs will control only the speed of your treadmill.**

To use programs from our Web site, the treadmill must be connected to your home computer. See HOW TO CONNECT YOUR COMPUTER on page 15. In addition, you must have an internet connection and an internet service provider. A list of specific system requirements will be found on our Web site.

Follow the steps below to use a program from our Web site.

1 Insert the key into the console.

See HOW TO TURN ON THE POWER on page 11.

2 Select the iFIT.com mode.

When the key is inserted, the manual mode will be selected. To use a program from our Web site, press the Mode button repeatedly until the iFIT.com indicator lights.



3 Go to your computer and start an internet connection.

4 Start your web browser, if necessary, and go to our Web site at www.iFIT.com.

5 Follow the desired links on our Web site to select a program.

Read and follow the on-line instructions for using a program.

6 Follow the on-line instructions to start the program.

When you start the program, an on-screen countdown will begin.

7 Return to the treadmill and stand on the foot rails. Find the clip attached to the key and slide the clip onto the waistband of your clothes.

When the on-screen countdown ends, the program will begin and the walking belt will begin to move. Hold the handrails, step onto the walking belt, and begin walking. During the program, an electronic “chirping” sound will alert you when the speed of the treadmill is about to change. **CAUTION: Always listen for the “chirp” and be prepared for speed changes.**

If the speed setting is too high or too low, you can manually override the setting at any time by pressing the Speed buttons on the console. **However, when the next “chirp” is heard, the speed will change to the next setting for the program.**

To stop the walking belt at any time, press the Stop button on the console. The Time display will begin to flash. To restart the program, press the Start button or the Speed Δ button. After a moment, the walking belt will begin to move. **When the next “chirp” is heard, the speed will change to the next setting for the program.**

When the program is completed, the walking belt will stop and the Time display will begin to flash. Note: To use another program, press the Stop button and go to step 5.

Note: If the speed of the treadmill does not change when a “chirp” is heard, make sure that the iFIT.com indicator is lit and that the Time display is not flashing. In addition, make sure that the audio cable is properly connected, that it is fully plugged in, and that it is not wrapped around a power cord.

8 Follow your progress with the LED track and the displays.

See step 5 on page 11.

9 Measure your heart rate, if desired.

See step 6 on page 12.

10 When the program is completed, remove the key.

See step 6 on page 13.

THE INFORMATION MODE

The console features an information mode that keeps track of the total number of hours that the treadmill has been operated and the total number of miles that the walking belt has moved. The information mode also allows you to switch the console from miles per hour to kilometers per hour.

To select the information mode, hold down the Stop button, insert the key into the console, and continue to hold the Stop button for a few seconds. When the information mode is selected, the following information will be shown:

The Time display will show the total number of hours the treadmill has been used.

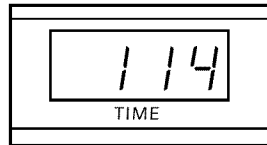

The Distance/Laps display will show the total number of miles (or kilometers) that the walking belt has moved.

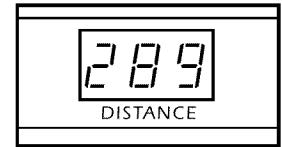

An "E" for english miles or an "M" for metric kilometers will appear in the Speed display. Press the Speed Δ button to change the unit of measurement.

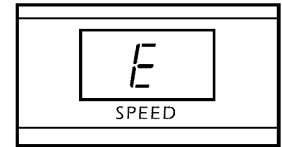

To exit the information mode, remove the key from the console.

HOW TO FOLD AND MOVE THE TREADMILL

HOW TO FOLD THE TREADMILL FOR STORAGE

Before folding the treadmill, adjust the incline to the lowest position. If this is not done, the treadmill may be permanently damaged. Next, unplug the power cord. **CAUTION:** You must be able to safely lift 45 pounds (20 kg) in order to raise, lower, or move the treadmill.

1. Hold the treadmill with your hands in the locations shown at the right. **CAUTION: To decrease the possibility of injury, bend your legs and keep your back straight. As you raise the treadmill, make sure to lift with your legs rather than your back.** Raise the treadmill about halfway to the vertical position.

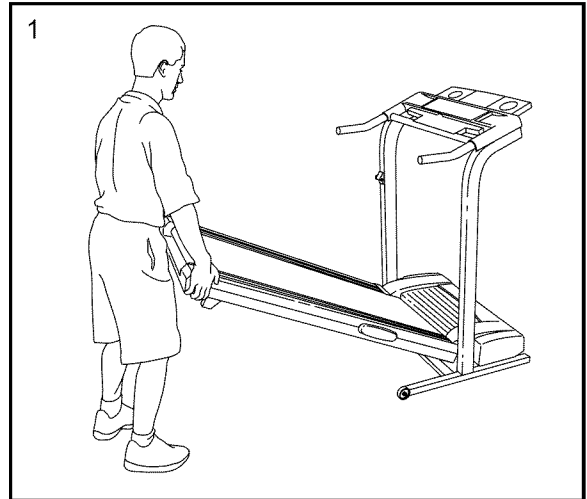

2. Move your right hand to the position shown and hold the treadmill firmly. Using your left hand, pull the latch knob to the left and hold it. Raise the treadmill until the catch is past the pin on the latch knob. Slowly release the latch knob. **Make sure that the catch is securely held by the pin.**

To protect the floor or carpet from damage, place a mat under the treadmill. Keep the treadmill out of direct sunlight. Do not leave the treadmill in the storage position in temperatures above 85° Fahrenheit.

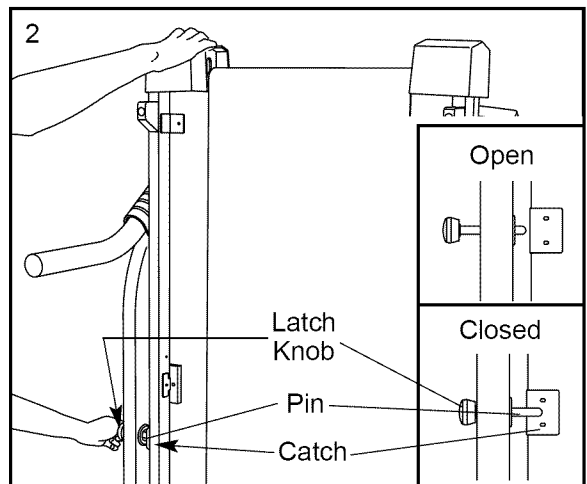

HOW TO MOVE THE TREADMILL

Before moving the treadmill, convert the treadmill to the storage position as described above. **Make sure that the catch is securely held by the pin on the latch knob.**

1. Hold the handrails as shown and place one foot against a wheel.
2. Tilt the treadmill back until it rolls freely on the wheels. Carefully move the treadmill to the desired location. **Never move the treadmill without tipping it back. To reduce the risk of injury, use extreme caution while moving the treadmill. Do not attempt to move the treadmill over an uneven surface.**
3. Place one foot on a wheel, and carefully lower the treadmill until it is resting in the storage position.

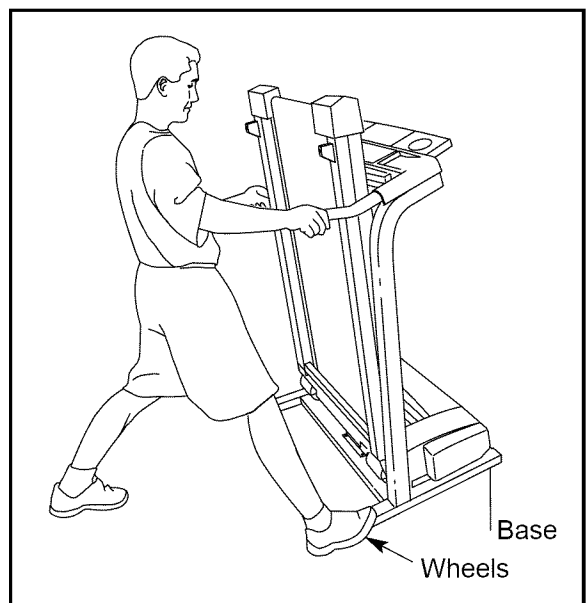

HOW TO LOWER THE TREADMILL FOR USE

1. Hold the upper end of the treadmill with your right hand as shown. Using your left hand, pull the latch knob to the left and hold it. Pivot the treadmill down until the frame is past the pin. Slowly release the latch knob.

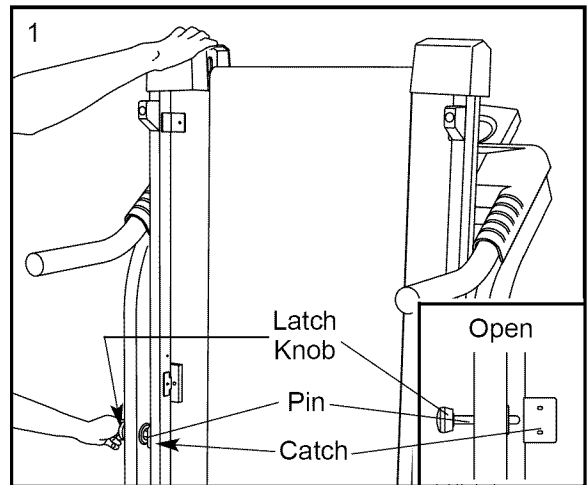

2. Hold the treadmill firmly with both hands, and lower the treadmill to the floor. **Do not drop the treadmill frame to the floor. CAUTION: To decrease the possibility of injury, bend your legs and keep your back straight.**

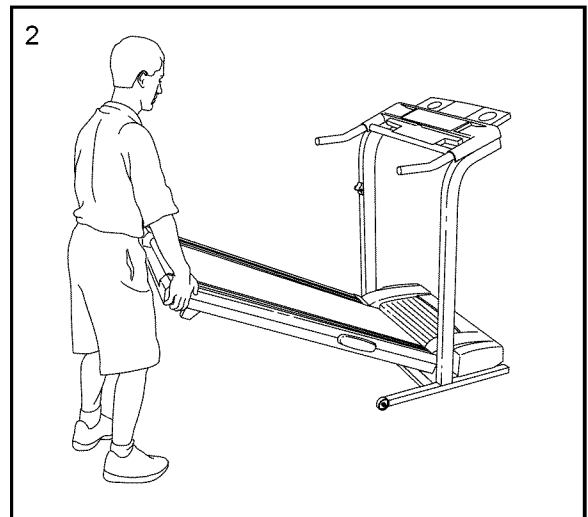

TROUBLESHOOTING

Most treadmill problems can be solved by following the steps below. Find the symptom that applies, and follow the steps listed. If further assistance is needed, please call our Customer Service Department toll-free at 1-800-999-3756, Monday through Friday, 6 a.m. until 6 p.m. Mountain Time (excluding holidays).

PROBLEM: The power does not turn on

SOLUTION: a. Make sure that the power cord is plugged into a surge suppressor, and that the surge suppressor is plugged into a properly grounded outlet (see page 9). Use only a single-outlet surge suppressor that meets all of the specifications described on page 9. Important: The treadmill is not compatible with GFCI-equipped outlets.

b. After the power cord has been plugged in, make sure that the key is fully inserted into the console.

c. Check the circuit breaker located on the treadmill near the power cord. If the switch protrudes as shown, the circuit breaker has tripped. To reset the circuit breaker, wait for five minutes and then press the switch back in.

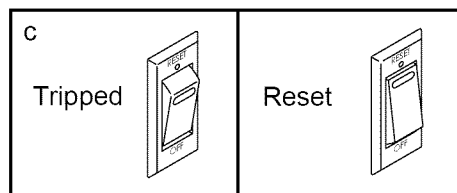

PROBLEM: The power turns off during use

SOLUTION: a. Check the circuit breaker located on the treadmill frame near the power cord (see c. above). If the circuit breaker has tripped, wait for five minutes and then press the switch back in.

b. Make sure that the power cord is plugged in. If the power cord is plugged in, unplug it, wait for five minutes, and then plug it back in.

c. Remove the key from the console. Reinsert the key fully into the console.

d. If the treadmill still will not run, please call our toll-free Customer Service Department.

PROBLEM: The speed display on the console does not function properly

SOLUTION: a. Remove the key and **UNPLUG THE POWER CORD**. Remove the hood from the treadmill. Locate the Reed Switch (21) and the Magnet (43) on the left side of the Pulley (42). Turn the Pulley until the Magnet is aligned with the Reed Switch. **Make sure that the gap between the Magnet and the Reed Switch is about 1/8"**. If necessary, loosen the 3/4" Screw (76) and move the Reed Switch slightly. Retighten the Screw. Re-attach the hood, and run the treadmill for a few minutes to check for a correct speed reading.

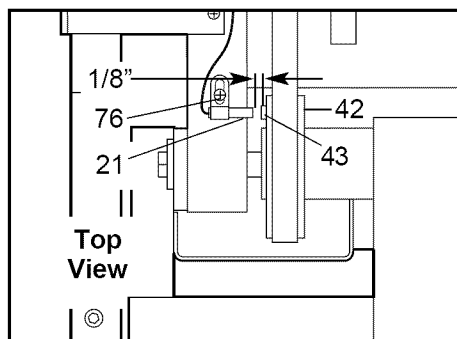

PROBLEM: The walking belt slows when walked on

SOLUTION: a. Use only a single-outlet surge suppressor that meets all of the specifications described on page 9.

b. If the walking belt is overtightened, treadmill performance may decrease and the walking belt may become damaged. Remove the key and **UNPLUG THE POWER CORD**. Using the allen wrench, turn both rear roller adjustment bolts counterclockwise, 1/4 of a turn. When the walking belt is properly tightened, you should be able to lift each side of the walking belt 3 to 4 inches off the walking platform. Be careful to keep the walking belt centered. Plug in the power cord, insert the key and run the treadmill for a few minutes. Repeat until the walking belt is properly tightened.

c. If the walking belt still slows when walked on, please call our toll-free Customer Service Department.

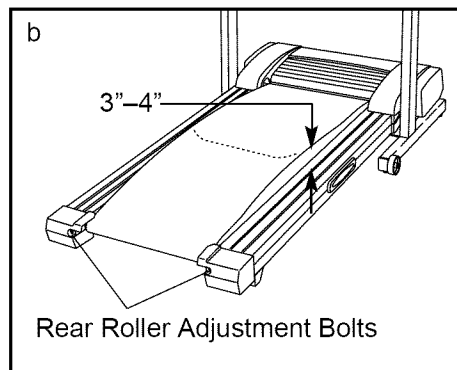

PROBLEM: The walking belt is off-center or slips when walked on

SOLUTION: a. If the walking belt is off-center, first remove the key and **UNPLUG THE POWER CORD**. If the walking belt has shifted to the left, use the allen wrench to turn the left rear roller bolt clockwise 1/2 of a turn; if the walking belt has shifted to the right, turn the bolt counterclockwise 1/2 of a turn. Be careful not to overtighten the walking belt. Plug in the power cord, insert the key and run the treadmill for a few minutes. Repeat until the walking belt is centered.

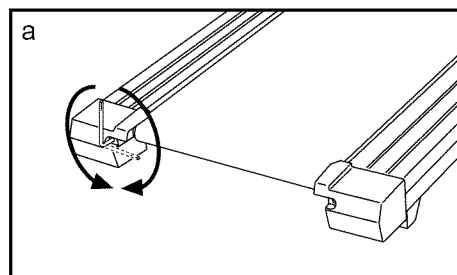

b. If the walking belt slips when walked on, first remove the key and **UNPLUG THE POWER CORD**. Using the allen wrench, turn both rear roller bolts clockwise, 1/4 of a turn. When the walking belt is correctly tightened, you should be able to lift each side of the walking belt 3 to 4 inches off the walking platform. Be careful to keep the walking belt centered. Plug in the power cord, insert the key and carefully walk on the treadmill for a few minutes. Repeat until the walking belt is properly tightened.

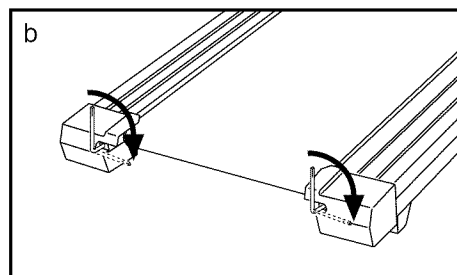

CONDITIONING GUIDELINES

⚠ WARNING: Before beginning this or any exercise program, consult your physician. This is especially important for individuals over the age of 35 or individuals with pre-existing health problems.

The pulse sensor is not a medical device. Various factors, including the user's movement, may affect the accuracy of heart rate readings. The pulse sensor is intended only as an exercise aid in determining heart rate trends in general.

The following guidelines will help you to plan your exercise program. For more detailed exercise information, obtain a reputable book or consult your physician.

EXERCISE INTENSITY

Whether your goal is to burn fat or to strengthen your cardiovascular system, the key to achieving the desired results is to exercise with the proper intensity. The proper intensity level can be found by using your heart rate as a guide. The chart below shows recommended heart rates for fat burning and aerobic exercise.

HEART RATE TRAINING ZONES							
AEROBIC	165	155	145	140	130	125	115
MAX FAT BURN	145	138	130	125	118	110	103
FAT BURN	125	120	115	110	105	95	90
Age	20	30	40	50	60	70	80

To find the proper heart rate for you, first find your age near the bottom of the chart (ages are rounded off to the nearest ten years). Next, find the three numbers above your age. The three numbers define your "training zone." The lower two numbers are recommended heart rates for fat burning; the higher number is the recommended heart rate for aerobic exercise.

To measure your heart rate during exercise, use the pulse sensor.

Fat Burning

To burn fat effectively, you must exercise at a relatively low intensity level for a sustained period of time. During the first few minutes of exercise, your body uses easily accessible *carbohydrate calories* for en-

ergy. Only after the first few minutes does your body begin to use stored *fat calories* for energy. If your goal is to burn fat, adjust the speed and incline of the treadmill until your heart rate is near the lowest number in your training zone.

For maximum fat burning, adjust the speed and incline of the treadmill until your heart rate is near the middle number in your training zone.

Aerobic Exercise

If your goal is to strengthen your cardiovascular system, your exercise must be "aerobic." Aerobic exercise is activity that requires large amounts of oxygen for prolonged periods of time. This increases the demand on the heart to pump blood to the muscles, and on the lungs to oxygenate the blood. For aerobic exercise, adjust the speed and incline of the treadmill until your heart rate is near the highest number in your training zone.

WORKOUT GUIDELINES

Each workout should include the following three parts:

A Warm-up—Start each workout with 5 to 10 minutes of stretching and light exercise. A proper warm-up increases your body temperature, heart rate and circulation in preparation for exercise.

Training Zone Exercise—After warming up, increase the intensity of your exercise until your pulse is in your training zone for 20 to 60 minutes. (During the first few weeks of your exercise program, do not keep your pulse in your training zone for longer than 20 minutes.) Breathe regularly and deeply as you exercise—never hold your breath.

A Cool-down—Finish each workout with 5 to 10 minutes of stretching to cool down. This will increase the flexibility of your muscles and will help prevent post-exercise problems.

EXERCISE FREQUENCY

To maintain or improve your condition, complete three workouts each week, with at least one day of rest between workouts. After a few months, you may complete up to five workouts each week if desired. The key to success is to make exercise a regular and enjoyable part of your everyday life.

SUGGESTED STRETCHES

The correct form for several basic stretches is shown at the right. Move slowly as you stretch—never bounce.

1. Toe Touch Stretch

Stand with your knees bent slightly and slowly bend forward from your hips. Allow your back and shoulders to relax as you reach down toward your toes as far as possible. Hold for 15 counts, then relax. Repeat 3 times. Stretches: Hamstrings, back of knees and back.

2. Hamstring Stretch

Sit with one leg extended. Bring the sole of the opposite foot toward you and rest it against the inner thigh of your extended leg. Reach toward your toes as far as possible. Hold for 15 counts, then relax. Repeat 3 times for each leg. Stretches: Hamstrings, lower back and groin.

3. Calf/Achilles Stretch

With one leg in front of the other, reach forward and place your hands against a wall. Keep your back leg straight and your back foot flat on the floor. Bend your front leg, lean forward and move your hips toward the wall. Hold for 15 counts, then relax. Repeat 3 times for each leg. To cause further stretching of the achilles tendons, bend your back leg as well. Stretches: Calves, achilles tendons and ankles.

4. Quadriceps Stretch

With one hand against a wall for balance, reach back and grasp one foot with your other hand. Bring your heel as close to your buttocks as possible. Hold for 15 counts, then relax. Repeat 3 times for each leg. Stretches: Quadriceps and hip muscles.

5. Inner Thigh Stretch

Sit with the soles of your feet together and your knees outward. Pull your feet toward your groin area as far as possible. Hold for 15 counts, then relax. Repeat 3 times. Stretches: Quadriceps and hip muscles.

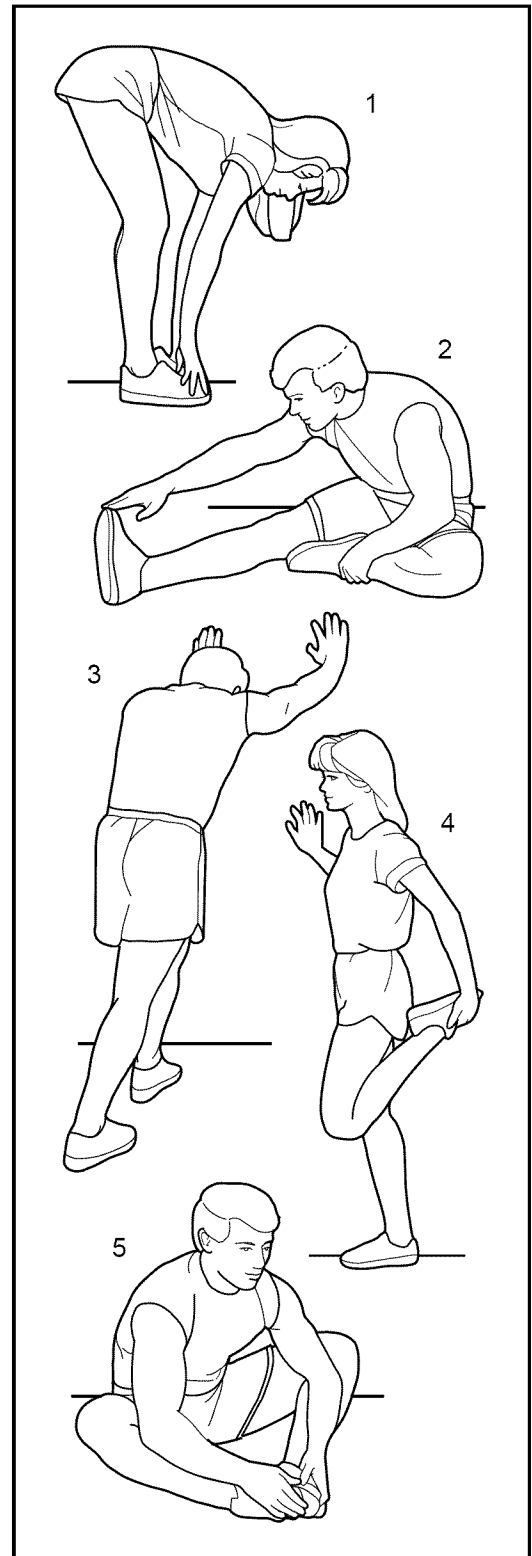

NOTES

PART LIST—Model No. IMTL39520

R0203A

To identify the parts listed below, see the EXPLODED DRAWING in the center of this manual.

Key No.	Qty.	Description	Key No.	Qty.	Description	Key No.	Qty.	Description
1	1	Motor Belt	45	2	Isolator	90	1	Key/Clip
2	1	Pulley/Flywheel/Fan	46	4	Isolator Fastener	91	1	Incline Motor Belly Pan
3	4	Motor Nut	47	4	3" Bolts	92	2	Roller Adj. Washer
4*	1	Motor/Pulley/ Flywheel/ Fan	48	1	Shield	93	1	Book Holder
5	1	Incline Motor Bolt	49	2	Belt Guide	94	1	Motor Hood
6	2	Incline Motor Spacer	50	1	Battery Cover	95	2	Front Wheel
7	1	Incline Motor	51	1	Front Belly Pan	96	1	Incline Motor Shield
8	1	Stop Bracket	52	8	U-Nut	97	4	Base Pad
9	1	Left Upright	53	3	Cable Tie Clamp	98	1	iFIT Wire
10	1	Right Upright	54	4	Cable Tie	99	1	Upright Grommet
11	1	Lock Pin	55	1	Walking Belt	100	1	Allen Wrench
12	1	Frame	56	1	Spring	101	5	3/4" Tek Screw
13	1	Pin Clip	57	1	Rear Roller	102	2	Handrail Endcap
14	1	Lock Pin Collar	58	4	Hood Screw	103	1	Power Board Plate
15	6	Wheel Nut/ Incline Motor Nut	59	2	Rear Foot	104	4	Base Cap
16	4	Belt Guide Screw	60	1	iFIT Jack	105	1	Lock Knob
17	1	Wire Harness	61	1	Ground Wire	106	1	Choke
18	2	Hood Bracket	62	20	Screw	107	1	Silver Screw
19	1	Front Hood Bracket	63	1	Left Rear Endcap	108	2	Plastic Tie
20	2	Warning Decal	64	1	Right Rear Endcap	109	1	Large Washer
21	1	Reed Switch	65	2	Rear Roller Adj. Bolt	110	1	Connector Cover
22	1	Reed Switch Clip	66	1	Motor	111	1	Hood Spacer
23	1	Left Handrail	67	1	Latch Decal	112	2	Bumper
24	1	Controller	68	6	Console Screw	113	1	Edge Guard
25	1	Electronics Bracket	69	2	Latch Catch Screw	114	2	Upright Endcap
26	1	Circuit Breaker	70	1	Latch Catch	115	2	Metal Plate
27	1	Power Cord	71	1	Walking Platform	116	2	Belly Pan Interface
28	1	Power Cord Grommet	72	5	8" Cable Tie	117	2	Rear Foot Spacer
29	10	Washer	73	1	Incline Bolt	118	2	Cup Holder
30*	1	Latch Assembly	74	1	Motor Tension Bolt	119	1	Power Board
31	1	Incline Frame	75	2	Right Foot Rail	120	1	Controller Wire
32	2	Frame Pivot Bolt	76	6	3/4" Screw	#	1	8" Blue Wire, 2F
33	2	Frame Pivot Spacer	77	1	Storage Latch Bracket	#	1	4" Blue Wire, 2F
34	1	Tension Bushing	78	1	Console	#	1	8" White Wire, 2F
35	1	Front Roller Adj. Bolt	79	4	1 1/2" Screw	#	1	8" White Wire, Pigtail
36	1	Foot Rail Cap (Right)	80	2	Incline Pivot Nut	#	1	4" White Wire, M/F
37	1	Motor Tension Nut	81	4	Motor Star Washer	#	1	8" Green Wire, 2 Ring
38	4	Motor Bolt	82	1	Base	#	1	User's Manual
39	4	Cap Screw	83	2	Incline Frame Bolt			
40	1	Foot Rail Cap (Left)	84	2	Motor Tension Washer			* Includes all parts shown in the box
41	1	Left Foot Rail	85	1	Right Handrail			# These parts are not illustrated
42	1	Front Roller/Pulley	86	2	Wheel Bolt			
43	1	Magnet	87	1	Console Base			
44	4	Platform Screw	88	1	Console Crossbar			
			89	4	4" Bolt			

EXPLODED DRAWING—Model No. IMTL39520

R0203A

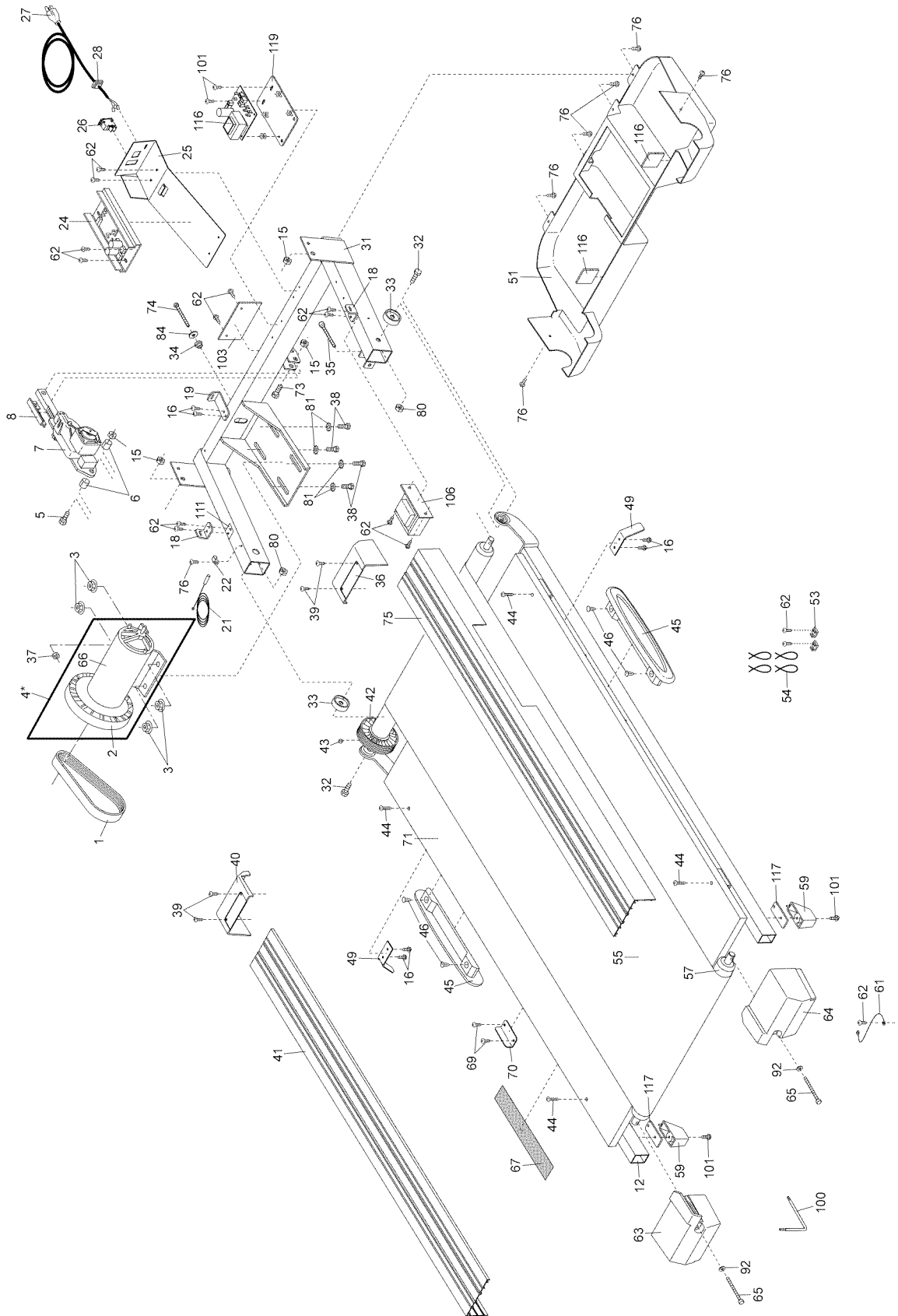

EXPLODED DRAWING—Model No. IMTL39520

R0203A

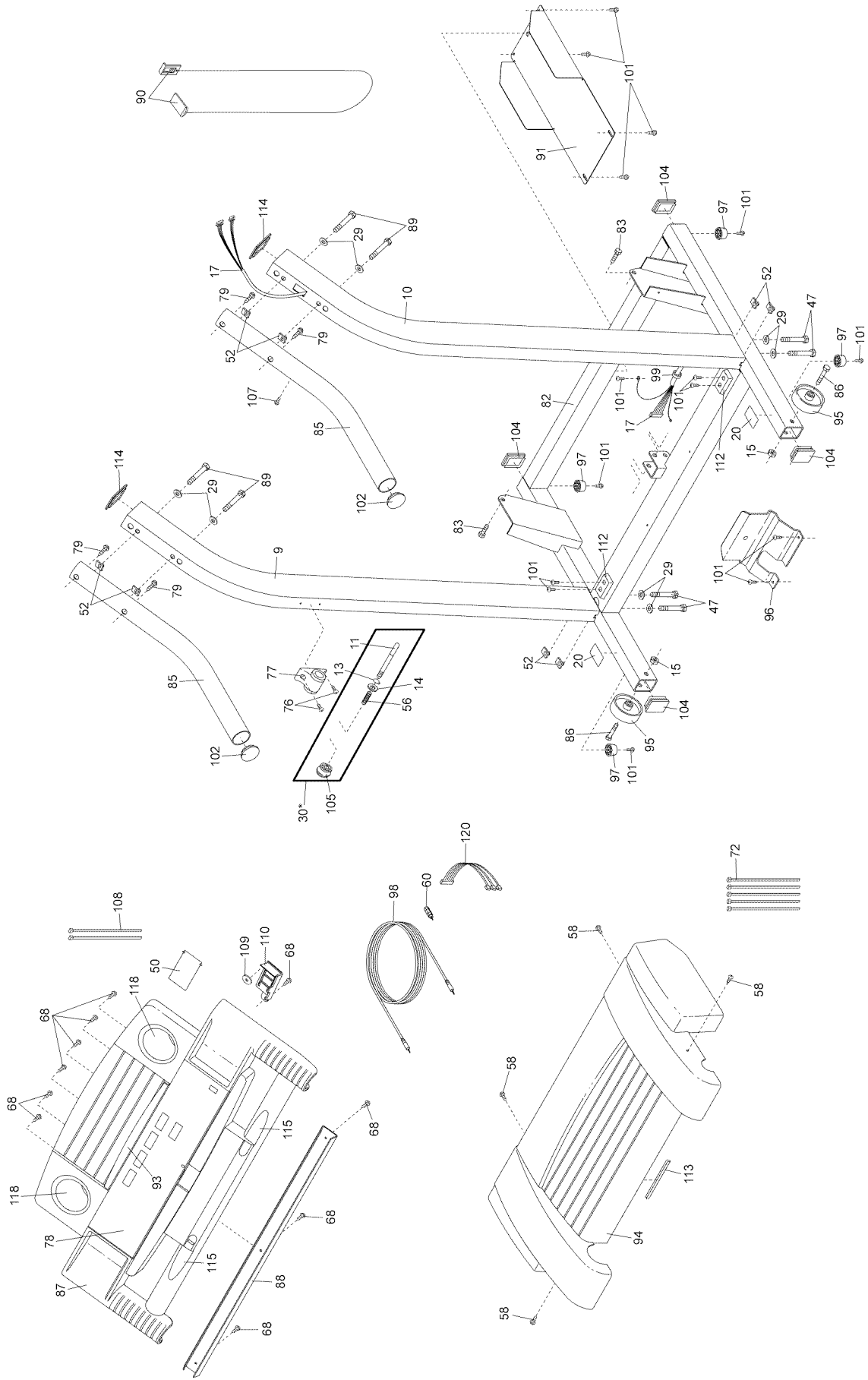

ORDERING REPLACEMENT PARTS

To order replacement parts, call our Customer Service Department toll-free at 1-800-999-3756, Monday through Friday, 6 a.m. until 6 p.m. Mountain Time (excluding holidays). When ordering parts, please be prepared to give the following information:

- The MODEL NUMBER OF THE PRODUCT (IMTL39520)
- The NAME OF THE PRODUCT (IMAGE® 10.0 treadmill)
- The SERIAL NUMBER OF THE PRODUCT (see the front cover of this manual)
- The KEY NUMBER AND DESCRIPTION OF THE PART(S) (see the PART LIST on page 27 and the EXPLODED DRAWING in the center of this manual)

LIMITED WARRANTY

ICON Health & Fitness, Inc. (ICON), warrants this product to be free from defects in workmanship and material, under normal use and service conditions, for a period of ninety (90) days from the date of purchase. This warranty extends only to the original purchaser. ICON's obligation under this warranty is limited to replacing or repairing, at ICON's option, the product through one of its authorized service centers. All repairs for which warranty claims are made must be pre-authorized by ICON. This warranty does not extend to any product or damage to a product caused by or attributable to freight damage, abuse, misuse, improper or abnormal usage or repairs not provided by an ICON authorized service center; products used for commercial or rental purposes; or products used as store display models. No other warranty beyond that specifically set forth above is authorized by ICON.

ICON is not responsible or liable for indirect, special or consequential damages arising out of or in connection with the use or performance of the product or damages with respect to any economic loss, loss of property, loss of revenues or profits, loss of enjoyment or use, costs of removal or installation or other consequential damages of whatsoever nature. Some states do not allow the exclusion or limitation of incidental or consequential damages. Accordingly, the above limitation may not apply to you.

The warranty extended hereunder is in lieu of any and all other warranties and any implied warranties of merchantability or fitness for a particular purpose is limited in its scope and duration to the terms set forth herein. Some states do not allow limitations on how long an implied warranty lasts. Accordingly, the above limitation may not apply to you.

This warranty gives you specific legal rights. You may also have other rights which vary from state to state.

ICON HEALTH & FITNESS, INC., 1500 S. 1000 W., LOGAN, UT 84321-9813