

SEARS

CRAFTSMAN[®]

MODEL NUMBER 917.372833 OWNER'S MANUAL

EZ³

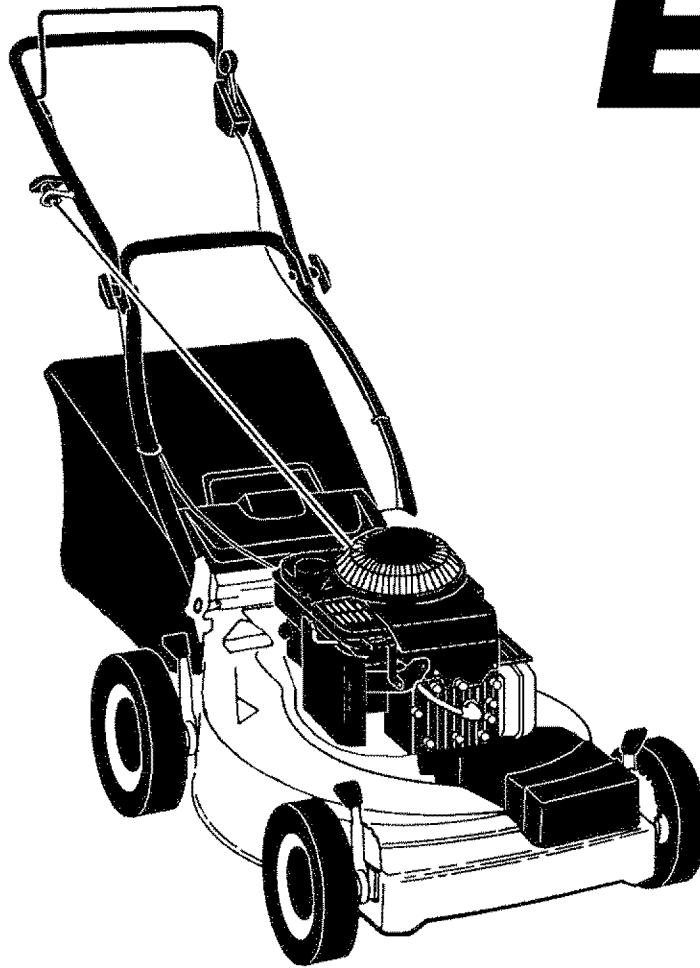

- Assembly
- Operation
- Customer Responsibilities
- Service
- Adjustments
- Repair Parts

**Caution:
Read and Follow
all Safety Rules
and Instructions
Before Operating
This Equipment**

153581 12.08.95 ks

Printed in U.S.A.

Sears, Roebuck and Co., Hoffman Estates, IL 60179 U.S.A.



SAFETY RULES



Safe Operation Practices for Walk-Behind Mowers

IMPORTANT: THIS CUTTING MACHINE IS CAPABLE OF AMPUTATING HANDS AND FEET AND THROWING OBJECTS. FAILURE TO OBSERVE THE FOLLOWING SAFETY INSTRUCTIONS COULD RESULT IN SERIOUS INJURY OR DEATH. SAFETY STANDARDS REQUIRE OPERATOR PRESENCE CONTROLS TO MINIMIZE THE RISK OF INJURY. YOUR UNIT IS EQUIPPED WITH SUCH CONTROLS. DO NOT ATTEMPT TO DEFEAT THE FUNCTION OF THE OPERATOR PRESENCE CONTROLS UNDER ANY CIRCUMSTANCES.

TRAINING:

- Read this operator's manual carefully. Become familiar with the controls and know how to operate your mower properly. Learn how to quickly stop mower.
- Do not allow children to use your mower. Never allow adults to use mower without proper instructions.
- Keep the area of operation clear of all persons, especially small children and pets.
- Use mower only as the manufacturer intended and as described in this manual.
- Do not operate mower if it has been dropped or damaged in any manner. Always have damage repaired before using your mower.
- Do not use accessory attachments that are not recommended by the manufacturer. Use of such attachments may be hazardous.
- The blade turns when the engine is running.

PREPARATION:

- Always thoroughly check the area to be mowed and clear it of all stones, sticks, wires, bones, and other foreign objects. These objects will be thrown by the blade and can cause severe injury.
- Always wear safety glasses or eye shields when starting and while using your mower.
- Dress properly. Do not operate mower when barefoot or wearing open sandals. Wear only solid shoes with good traction when mowing.
- Check fuel tank before starting engine. Do not fill gas tank indoors, when the engine is running or when the engine is hot. Allow the engine to cool for several minutes before filling the gas tank. Clean off any spilled gasoline before starting the engine.
- Always make wheel height adjustments before starting your mower. Never attempt to do this while the engine is running.
- Mow only in daylight or good artificial light.

OPERATION:

- Keep your eyes and mind on your mower and the area being cut. Do not let other interests distract you.
- Do not mow wet or slippery grass. Never run while operating your mower. Always be sure of your footing - keep a firm hold on the handles and walk.
- Do not put hands or feet near or under rotating parts. Keep clear of the discharge opening at all times.
- Always stop the engine whenever you leave or are not using your mower, or before crossing driveways, walks, roads, and any gravel-covered areas.
- Never direct discharge of material toward bystanders nor allow anyone near the mower while you are operating it.
- Before cleaning, inspecting, or repairing your mower, stop the engine and make absolutely sure the blade and all moving parts have stopped. Then disconnect the spark plug wire and keep it away from the spark plug to prevent accidental starting.

- Do not continue to run your mower if you hit a foreign object. Follow the procedure outlined above, then repair any damage before restarting and operating you mower.
- Do not change the governor settings or overspeed the engine. Engine damage or personal injury may result.
- Do not operate your mower if it vibrates abnormally. Excessive vibration is an indication of damage; stop the engine, safely check for the cause of vibration and repair as required.
- Do not run the engine indoors. Exhaust fumes are dangerous.
- Never cut grass by pulling the mower towards you. Mow across the face of slopes, never up and down or you might lose your footing. Do not mow excessively steep slopes. Use caution when operating the mower on uneven terrain or when changing directions - maintain good footing.
- Never operate your mower without proper guards, plates, grass catcher or other safety devices in place.

MAINTENANCE AND STORAGE:

- Check the blade and the engine mounting bolts often to be sure they are tightened properly.
- Check all bolts, nuts and screws at frequent intervals for proper tightness to be sure mower is in safe working condition.
- Keep all safety devices in place and working.
- To reduce fire hazard, keep the engine free of grass, leaves or excessive grease and oil.
- Check grass catcher often for deterioration and wear and replace worn bags. Use only replacement bags that are recommended by and comply with specifications of the manufacturer of your mower.
- Always keep a sharp blade on your mower.
- Allow engine to cool before storing in any enclosure.
- Never store mower with fuel in the tank inside a building where fumes may reach an open flame or an ignition source such as a hot water heater, space heater, clothes dryer, etc.



Look for this symbol to point out important safety precautions. It means CAUTION!!! BECOME ALERT!!! YOUR SAFETY IS INVOLVED.



CAUTION: Always disconnect spark plug wire and place wire where it cannot contact spark plug in order to prevent accidental starting when setting up, transporting, adjusting or making repairs.



The engine exhaust from this product contains chemicals known to the State of California to cause cancer, birth defects, or other reproductive harm.

CONGRATULATIONS on your purchase of a Sears Lawn Mower. It has been designed, engineered and manufactured to give you the best possible dependability and performance.

Should you experience any problem you cannot easily remedy, please contact your nearest Sears Authorized Service Center/Department. We have competent, well-trained technicians and the proper tools to service or repair this lawn mower.

Please read and retain this manual. The instructions will enable you to assemble and maintain your lawn mower properly. Always observe the "SAFETY RULES".

PRODUCT SPECIFICATIONS

| | |
|-------------------------------|---|
| HORSEPOWER: | 5.5 |
| DISPLACEMENT: | 12.6 CU. IN. |
| GASOLINE CAPACITY AND TYPE: | 1.6 QUARTS UNLEADED REGULAR |
| OIL TYPE (API-SF/SG): | SAE 30 (ABOVE 32°F) SAE 5W-30 (below 32°F) |
| OIL CAPACITY: | 20 OZS. |
| SPARK PLUG: (GAP: .030") | CHAMPION J19LM, RJ19LM STD361458 |
| VALVE CLEARANCE: | INTAKE: .005" - .007" EXHAUST: .007" - .009" |
| SOLID STATE IGNITION AIR GAP: | .0125 IN. |
| BLADE BOLT TORQUE: | 35-40 FT. LBS. |

MODEL NUMBER 917.372833

SERIAL NUMBER _____

DATE OF PURCHASE _____

THE MODEL AND SERIAL NUMBERS WILL BE FOUND ON A DECAL ATTACHED TO THE REAR OF THE LAWN MOWER HOUSING

YOU SHOULD RECORD BOTH SERIAL NUMBER AND DATE OF PURCHASE AND KEEP IN A SAFE PLACE FOR FUTURE REFERENCE.

MAINTENANCE AGREEMENT

A Sears Maintenance Agreement is available on this product. Contact your nearest Sears store for details.

CUSTOMER RESPONSIBILITIES

- Read and observe the safety rules.
- Follow a regular schedule in maintaining, caring for and using your lawn mower.
- Follow the instructions under "Customer Responsibilities" and "Storage" sections of this owner's manual.

LIMITED TWO YEAR WARRANTY ON CRAFTSMAN POWER MOWER

For two years from date of purchase, when this Craftsman Lawn Mower is maintained, lubricated, and tuned up according to the operating and maintenance instructions in the owner's manual, Sears will repair free of charge any defect in material or workmanship.

If this Craftsman Lawn Mower is used for commercial or rental purposes, this warranty applies for only 90 days from the date of purchase.

This Warranty does not cover:

- Expendable items which become worn during normal use, such as rotary mower blades, blade adapters, belts, air cleaners and spark plug.
- Repairs necessary because of operator abuse or negligence, including bent crankshafts and the failure to maintain the equipment according to the instructions contained in the owner's manual.

WARRANTY SERVICE IS AVAILABLE BY RETURNING THE CRAFTSMAN POWER MOWER TO THE NEAREST SEARS SERVICE CENTER/DEPARTMENT IN THE UNITED STATES. THIS WARRANTY APPLIES ONLY WHILE THIS PRODUCT IS IN USE IN THE UNITED STATES.

This Warranty gives you specific legal rights, and you may also have other rights which vary from state to state.

SEARS, ROEBUCK AND CO., D/817 WA, HOFFMAN ESTATES, ILLINOIS 60179

TABLE OF CONTENTS

| | | | |
|---------------------------------|----------|---------------------------------|-------|
| SAFETY RULES | 2 | SERVICE AND ADJUSTMENTS | 15 |
| PRODUCT SPECIFICATIONS | 3 | STORAGE | 17 |
| CUSTOMER RESPONSIBILITIES | 3, 12-14 | TROUBLESHOOTING | 19 |
| WARRANTY | 3 | REPAIR PARTS - LAWN MOWER | 20-24 |
| ASSEMBLY | 6 | REPAIR PARTS - ENGINE | 25-30 |
| OPERATION | 8 | PARTS ORDERING/SERVICE | 32 |
| MAINTENANCE SCHEDULE | 12 | | |



INDEX

| | | | | | |
|-------------------------------|----------|-----------------------------|----|-------------------------------|----------|
| A | | E | | Operation: | |
| Accessories | 5 | Engine: | | Drive Control | 9 |
| Adjustments: | | Air Filter | 14 | Engine Control | 9 |
| Carburetor | 16 | Oil Change | 14 | Grass Catcher | 9 |
| Drive Belt | 15 | Oil Level | 14 | Mower | 9 |
| Engine Speed | 16 | Oil Type | 14 | Operator Presence | |
| Handle Height | 16 | Starting | 10 | Control Bar | 9 |
| Height of Cut | 9 | Stopping | 10 | Options: | |
| Air Filter: | | Storage | 16 | Accessories | 5 |
| Replacement | 14 | F | | R | |
| Service | 14 | Fuel: | | Repair Parts: | |
| Assembly | 6 | Capacity | 3 | Engine | 25-30 |
| B | | Storage | 16 | Lawn Mower | 20-24 |
| Blade: | | Type | 10 | Responsibilities, Customer .. | 3, 12-14 |
| Sharpening | 13 | H | | S | |
| Replacement | 13 | Handle Adjustment: | | Safety Rules | 2 |
| C | | Assembly | 6 | Service and Adjustments | 15 |
| Controls: | | Cutting Height | 16 | Carburetor | 16 |
| Drive Control | 8 | L | | Drive Belt | 15 |
| Engine Zone Control | 8 | Lubrication: | | Engine Speed | 16 |
| Engine Speed Control | 8 | Engine | 14 | Handle | 16 |
| Operator Presence | | Lawn Mower | 12 | Spark Plug | 14 |
| Control Bar | 8 | M | | Specifications | 3 |
| Customer Responsibilities ... | 3, 12-14 | Maintenance Agreement | 3 | Speed Control: | |
| Air Filter | 14 | Maintenance Schedule | 12 | Engine | 8 |
| Blade Care/Replacement | 13 | Mowing Tips | 10 | Starting the Engine | 10 |
| Drive Wheels | 13 | O | | Stopping the Engine | 10 |
| Engine | 14 | Oil: | | Storage | 16 |
| Lubrication | 14 | Engine | 12 | T | |
| Spark Plug | 14 | Storage | 16 | Trouble Shooting Chart | 19 |
| Cutting Levels | 9 | W | | Warranty | 3 |



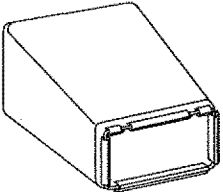
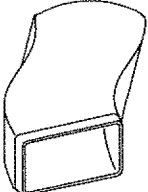
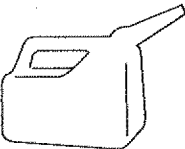

LAWN MOWER ACCESSORIES

These accessories were available when this lawn mower was produced. They are also available at most Sears retail outlets and service centers. Most Sears stores can also order repair parts for you, when you provide the model number of your lawn mower. Some of these accessories may not apply to your lawn mower.

LAWN MOWER PERFORMANCE

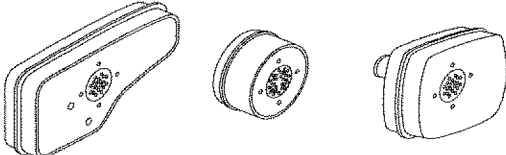
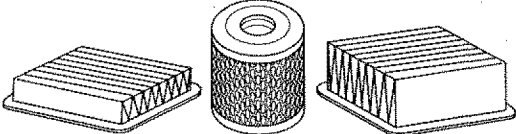
| | | |
|---|---|--|
|  <p>CLIPPING DEFLECTOR FOR REAR DISCHARGE LAWN MOWERS</p> |  <p>MULCHER KITS</p> |  <p>STABILIZER</p> |
|  <p>GRASS CATCHERS FOR REAR DISCHARGE LAWN MOWERS</p> |  <p>GRASS CATCHERS FOR SIDE DISCHARGE LAWN MOWERS</p> |  <p>GAS CANS</p> |

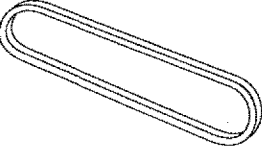
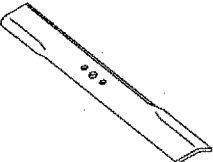
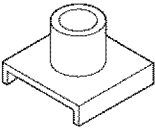
LAWN MOWER MAINTENANCE

| | | | | |
|---|--|--|--|--|
|  <p>MUFFLERS</p> | |  <p>AIR FILTERS</p> | |  <p>SPARK PLUGS</p> |
|  <p>BELTS</p> |  <p>BLADES</p> |  <p>BLADE ADAPTERS</p> |  <p>WHEELS</p> |  <p>ENGINE OIL</p> |

ASSEMBLY

Read these instructions and this manual in its entirety before you attempt to assemble or operate your new lawn mower. Your new lawn mower has been assembled at the factory with the exception of those parts left unassembled for shipping purposes. All parts such as nuts, washers, bolts, etc., necessary to complete the assembly have been placed in the parts bag. To ensure safe and proper operation of your lawn mower, all parts and hardware you assemble must be tightened securely. Use the correct tools as necessary to ensure proper tightness.

TO REMOVE LAWN MOWER FROM CARTON

- Remove loose parts included with mower.
- Cut down two end corners of carton and lay end panel down flat.
- Remove all packing materials except padding between upper and lower handle and padding holding operator presence control bar to upper handle.
- Roll lawn mower out of carton and check carton thoroughly for additional loose parts.

HOW TO SET UP YOUR LAWN MOWER TO UNFOLD HANDLE (See Fig. 1)

IMPORTANT: UNFOLD HANDLES CAREFULLY SO AS NOT TO PINCH OR DAMAGE CONTROL CABLES.

- Raise handles until lower handle section locks into place in mowing position.
- Raise upper handle section into place on lower handle, remove protective padding and tighten both handle knobs.
- Remove handle padding holding operator presence control bar to upper handle.
- Your lawn mower handle can be adjusted for your mowing comfort. Refer to "Adjust Handle" in the Service and Adjustment section of this manual.

TO INSTALL ATTACHMENTS (See Fig. 2)

Your lawn mower was shipped ready to be used as a mulcher. To convert to bagging or discharging:

- Open rear door and remove mulcher plate. Store mulcher plate in a safe place.
- You can now install catcher or optional clipping deflector.
- To return to mulching operation, install mulcher plate into discharge opening of mower. Be sure all tabs are seated properly.

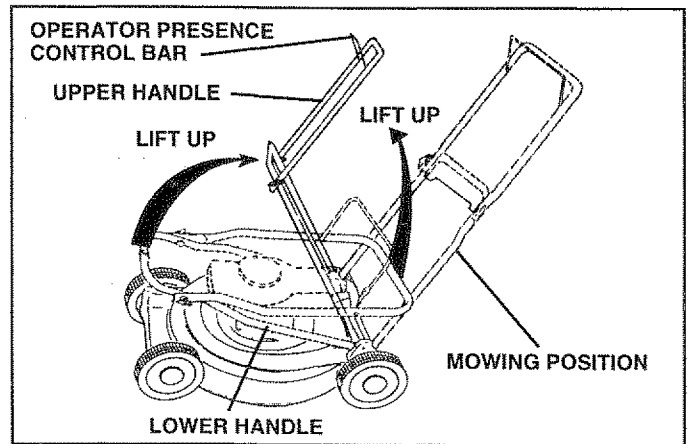

FIG. 1

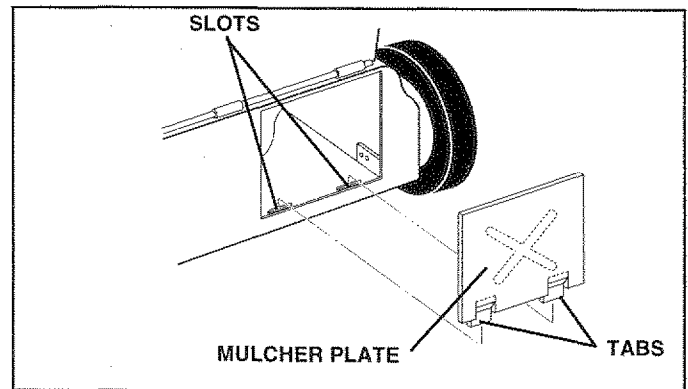

FIG. 2



CAUTION: Do not run your lawn mower without mulcher plate in place or approved clipping deflector or grass catcher in place. Never attempt to operate the lawn mower with the rear door removed or propped open.

ASSEMBLY

TO ASSEMBLE AND ATTACH GRASS CATCHER (See Figs. 3A thru 4)

- Insert leg of tubular frame through front opening of grass catcher and thread frame into sewn hem of bag.

NOTE: Keep bag hem gathered on the straight leg of the tubular frame.

- When frame comes out the other end of sewn hem, immediately work the end of frame down inside the bag as shown in inset.
- Slide sewn hem evenly around the tubular frame until both ends of frame are exposed out of the front opening.
- Assemble lower frame to tubular frame as shown. Be sure handle is outside of bag and frames are fully seated as shown in inset.
- Slip vinyl bindings over frame.

NOTE: If vinyl bindings are too stiff, hold them in warm water for a few minutes. If bag gets wet, let it dry before using.

- Close the flip lid. Flip lid must be closed while operating lawn mower.
- Lift the rear door on the mower housing and place the grass catcher frame onto the formed tabs on the rear door hinge bracket.
- The grass catcher is secured to the lawn mower housing when the rear door is lowered onto the grass catcher frame.

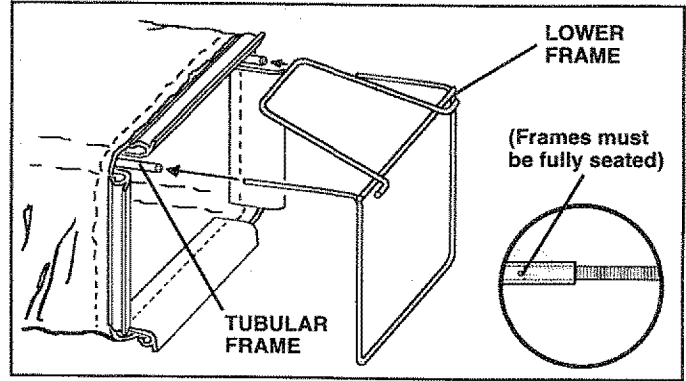

FIG. 3B

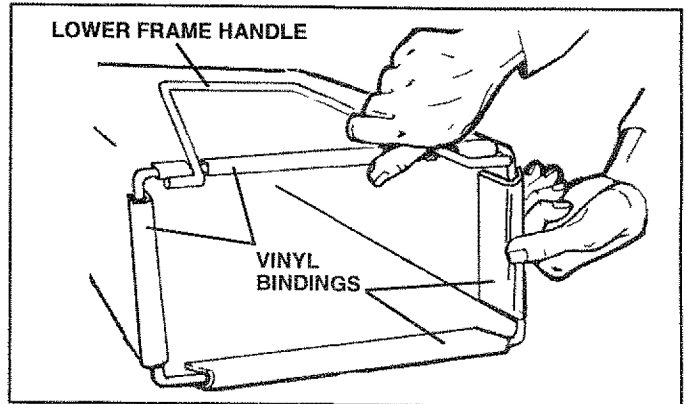

FIG. 3C

CAUTION: Do not run your lawn mower without clipping deflector or approved grass catcher in place. Never attempt to operate the lawn mower with the rear door removed or propped open.

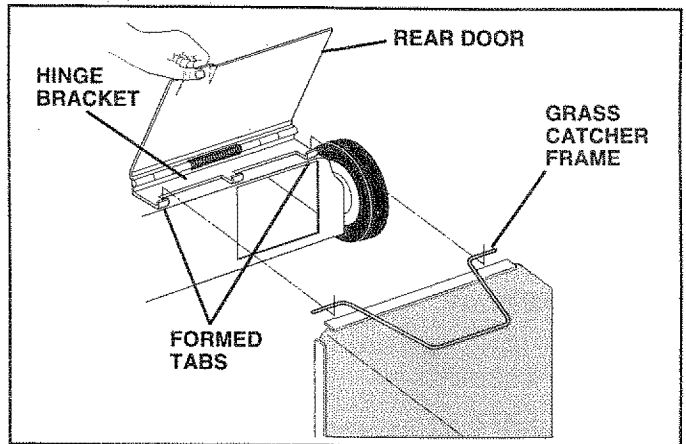

FIG. 4

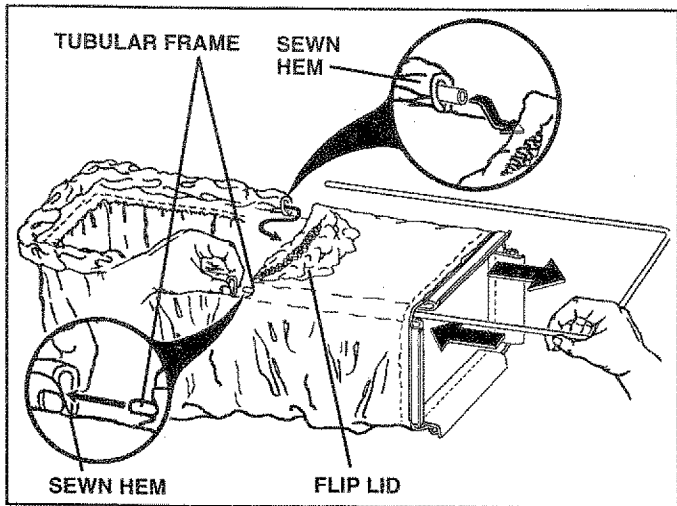

FIG. 3A

OPERATION

KNOW YOUR LAWN MOWER

READ THIS OWNER'S MANUAL AND SAFETY RULES BEFORE OPERATING YOUR LAWN MOWER. Compare the illustrations with your lawn mower to familiarize yourself with the location of various controls and adjustments. Save this manual for future reference.

These symbols may appear on your lawn mower or in literature supplied with the product. Learn and understand their meaning.

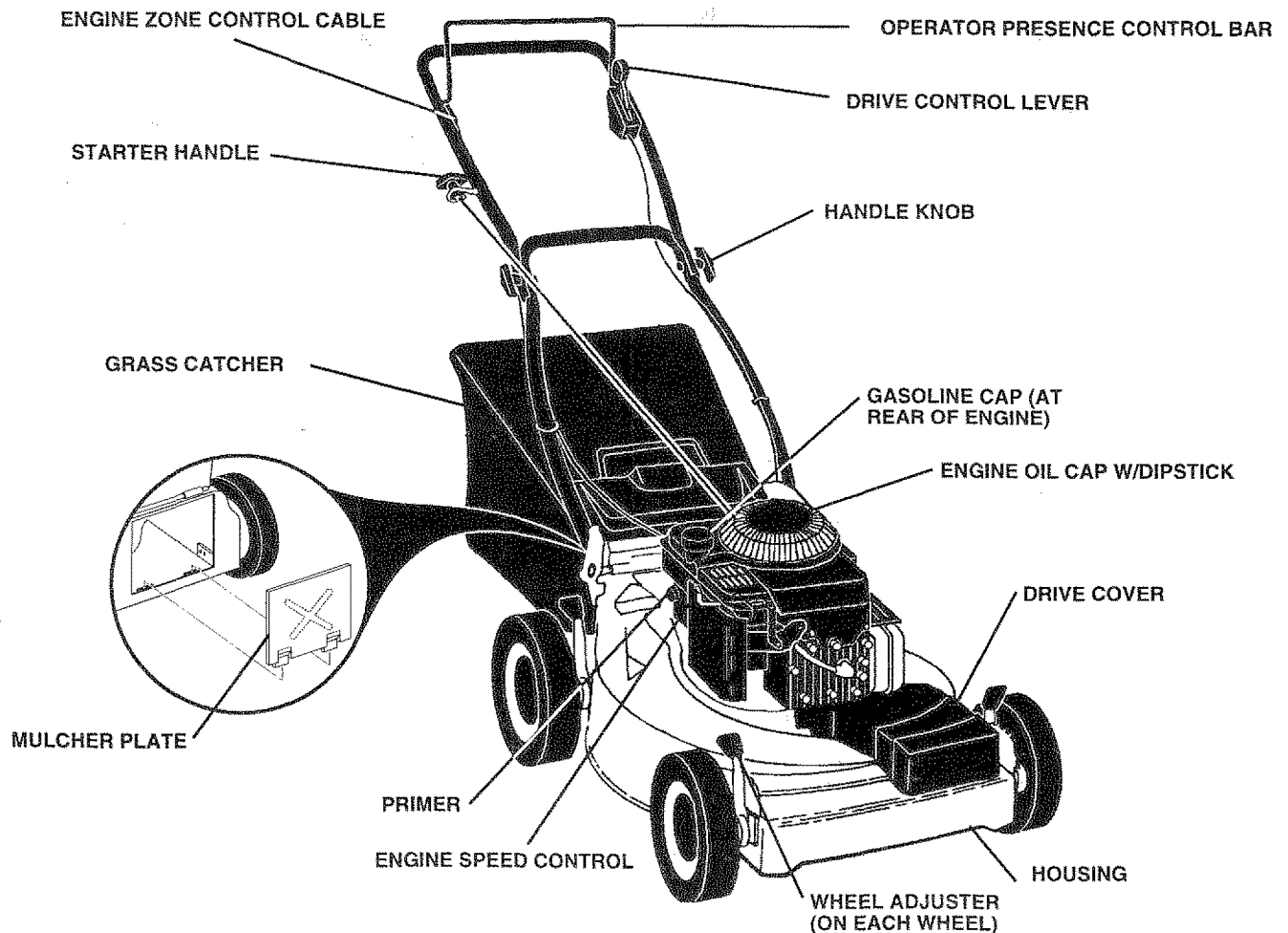
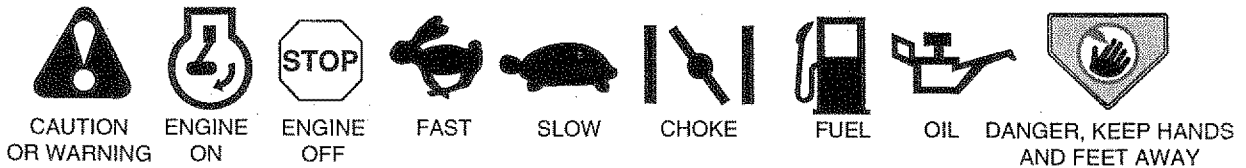

MEETS CPSC SAFETY REQUIREMENTS

Sears rotary walk-behind power lawn mowers conform to the safety standards of the American National Standards Institute and the U.S. Consumer Product Safety Commission. The blade turns when the engine is running.

OPERATOR PRESENCE CONTROL - must be held down to the handle to start the engine. Release to stop the engine.

PRIMER - pumps additional fuel from the carburetor to the cylinder for use when starting a cold engine.

STARTER HANDLE - used for starting the engine.

DRIVE CONTROL LEVER - used to engage power-propelled forward motion of lawn mower.

ENGINE SPEED CONTROL - located on the side of the engine which allows you to select either fast (🐇) or slow (🐢) engine speed.

MULCHER PLATE - must be removed to convert to bagging or discharging operation.

OPERATION



The operation of any lawn mower can result in foreign objects thrown into the eyes, which can result in severe eye damage. Always wear safety glasses or eye shields while operating your lawn mower or performing any adjustments or repairs. We recommend a wide vision safety mask over the spectacles or standard safety glasses.

HOW TO USE YOUR LAWN MOWER



CAUTION: Do not run your lawn mower without mulcher plate in place and door closed or without an approved clipping deflector or grasscatcher in place. Never attempt to operate the lawn mower with the rear door removed or propped open.

ENGINE SPEED (See Fig. 5)

The engine speed is controlled by a lever located on the side of the engine. Fast (☛) position is for starting the engine, normal cutting and better grass bagging. Slow (☛) position is for light cutting, trimming and fuel economy.

ENGINE ZONE CONTROL



CAUTION: Federal regulations require an engine control to be installed on this lawn mower in order to minimize the risk of blade contact injury. Do not under any circumstances attempt to defeat the function of the operator control. The blade turns when the engine is running.

- Your lawn mower is equipped with an operator presence control bar which requires the operator to be positioned behind the lawn mower handle to start and operate the lawn mower.

TO ADJUST CUTTING HEIGHT (See Fig. 6)

- Raise wheels for low cut and lower wheels for high cut.
- Wheels are set in low cut for shipping. Adjust cutting height to suit your requirements. Medium position is best for most lawns.
- To change cutting height, squeeze adjuster lever toward wheel. Move wheel up or down to suit your requirements. Be sure all wheels are in the same setting.

TO EMPTY GRASS CATCHER (See Fig. 7)

- To remove grass catcher, release operator presence control bar to stop engine.
- Lift up rear door and remove the grass catcher by the handle.
- Do not drag the bag when emptying; it will cause unnecessary wear.

DRIVE CONTROL (See Fig. 8)

- Self-propelling is controlled by holding the operator presence control bar down to the handle and pushing the drive control lever forward until it clicks; then release the lever.
- Forward motion will stop when the operator presence control bar is released. To stop forward motion without stopping engine, release the operator presence control bar slightly until the drive control disengages. Hold operator presence control bar down to handle to continue mowing without self-propelling.

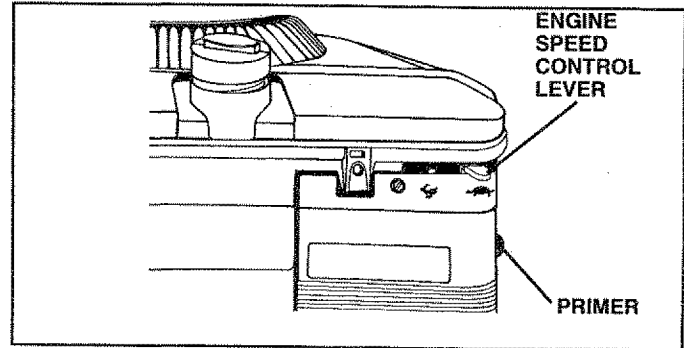

FIG. 5

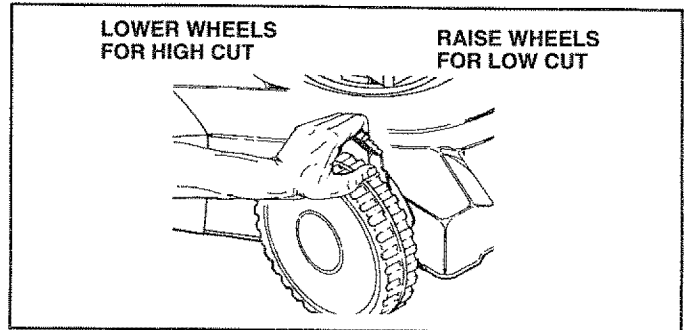

FIG. 6

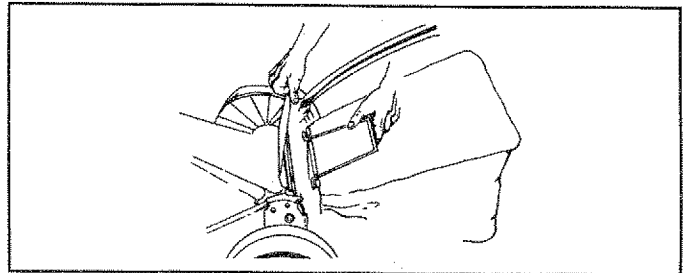

FIG. 7

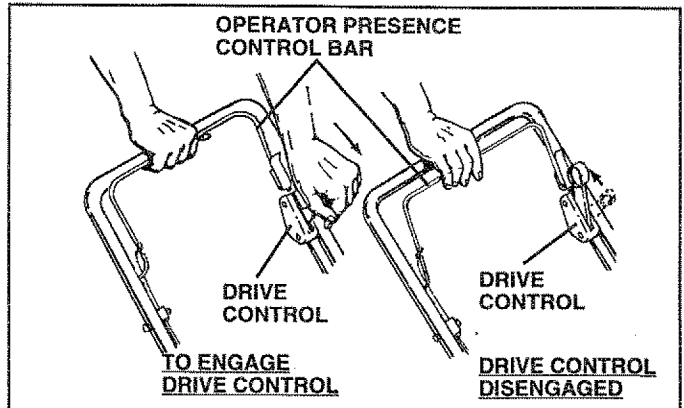

FIG. 8

- To keep drive control engaged when turning corners, push down on handle and lift front wheels off ground while turning lawn mower.

OPERATION

BEFORE STARTING ENGINE

OIL (See Fig. 9)

Your lawn mower is shipped without oil in the engine.

- Be sure mower is level and area around oil fill is clean.
- Remove engine oil cap w/dipstick and fill to the full line on the dipstick.
- Use 20 ozs. of oil. For type and grade of oil to use, see "ENGINE" in Customer Responsibilities section of this manual.
- Pour oil slowly. Do not over fill.
- Check oil level before each use. Add oil if needed. Fill to full line on dipstick.
- To read proper level, tighten engine oil cap each time.
- Reinstall engine oil cap and tighten.
- After the first two (2) hours of mowing, change the oil, and every 25 hours thereafter. You may need to change the oil more often under dusty, dirty conditions.

GAS (See Fig. 9)

- Fill fuel tank. Use fresh, clean, regular unleaded gasoline with a minimum of 87 octane. (Use of leaded gasoline will increase carbon and lead oxide deposits and reduce valve life). Do not mix oil with gasoline. Purchase fuel in quantities that can be used within 30 days to assure fuel freshness.

WARNING: Experience indicates that alcohol blended fuels (called gasohol or using ethanol or methanol) can attract moisture which leads to separation and formation of acids during storage. Acidic gas can damage the fuel system of an engine while in storage. To avoid engine problems, the fuel system should be emptied before storage of 30 days or longer. Drain the fuel tank, start the engine and let it run until fuel lines and carburetor are empty. Use fresh fuel next season. See Storage Instructions for additional information. Never use engine or carburetor cleaner products in fuel tank or permanent damage may occur.

TO START ENGINE

- To start a cold engine, push primer three (3) times before trying to start. Use a firm push. This step is not usually necessary when starting an engine which has already run for a few minutes.
- Move throttle control lever to fast (🔥) position.
- Hold operator presence control bar down to the handle and pull starter handle quickly. Do not allow starter rope to snap back.
- To stop engine, release operator presence control bar.

NOTE: In cooler weather it may be necessary to repeat priming steps. In warmer weather over priming may cause flooding and engine will not start. If you do flood engine, wait a few minutes before attempting to start and do not repeat priming steps.

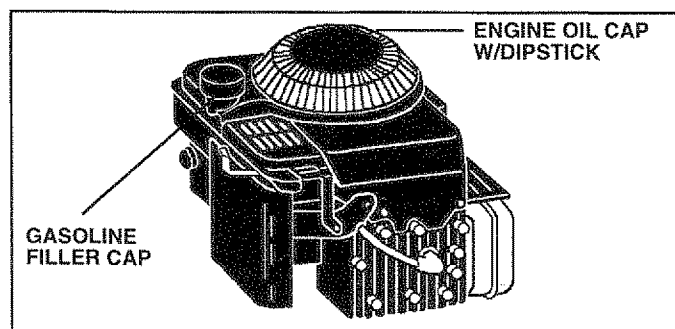

FIG. 9

MOWING TIPS

- Under certain conditions, such as very tall grass, it may be necessary to raise the height of cut to reduce pushing effort and to keep from overloading the engine and leaving clumps of grass clippings.
- For extremely heavy cutting, reduce the width of cut and raise the rear of the lawn mower housing one (1) wheel adjuster setting higher than the front for better discharge of grass.
- For better grass bagging and most cutting conditions, the engine speed should be set in the fast (🔥) position.
- When using a rear discharge lawn mower in moist, heavy grass, clumps of cut grass may not enter the grass catcher. Reduce ground speed (pushing speed) and/or run the lawn mower over the area a second time.
- If a trail of grass clippings is left on the right side of a rear discharge lawn mower, mow in a clockwise direction with a small overlap to collect the clippings on the next pass.
- Keep top of engine around starter clear and clean of grass clippings and chaff. This will help engine air flow and extend engine life.
- Pores in cloth grass catchers can become filled with dirt and dust with use and catchers will collect less grass. To prevent this, regularly hose catchers off with water and let dry before using.

OPERATION

MULCHING MOWING TIPS

IMPORTANT: FOR BEST PERFORMANCE, KEEP MOWER HOUSING FREE OF BUILT-UP GRASS AND TRASH. SEE "CLEANING" IN CUSTOMER RESPONSIBILITIES SECTION OF THIS MANUAL.

- The special mulching blade will recut the grass clippings many times and reduce them in size so that as they fall onto the lawn they will disperse into the grass and not be noticed. Also, the mulched grass will biodegrade quickly to provide nutrients for the lawn. Always mulch with your highest engine (blade) speed as this will provide the best recutting action of the blades.
- Avoid cutting your lawn when it is wet. Wet grass tends to form clumps and interferes with the mulching action. The best time to mow your lawn is the early afternoon. At this time the grass has dried and the newly cut area will not be exposed to the direct sun.
- For best results, adjust the lawn mower cutting height so that the lawn mower cuts off only the top one-third of the grass blades (See Fig. 10). If the lawn is overgrown it will be necessary to raise the height of cut to reduce pushing effort and to keep from overloading the engine and leaving clumps of mulched grass. For extremely heavy mulching, reduce your width of cut by overlapping previously cut path and mow slowly.
- Certain types of grass and grass conditions may require that an area be mulched a second time to completely hide the clippings. When doing a second cut, mow across or perpendicular to the first cut path.
- Change your cutting pattern from week to week. Mow north to south one week then change to east to west the next week. This will help prevent matting and graining of the lawn.

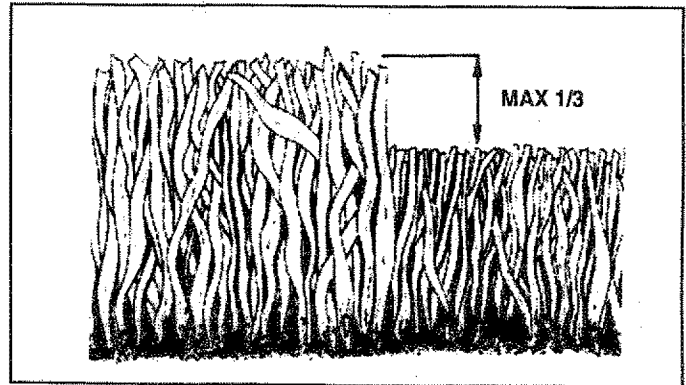

FIG. 10

CUSTOMER RESPONSIBILITIES

| MAINTENANCE SCHEDULE | | SERVICE INTERVALS | | | | | | SERVICE DATES | | | | | |
|----------------------|---|-------------------|----------------|---------------|----------------|------------------|----------------|----------------|--|--|--|--|--|
| | | BEFORE EACH USE | AFTER EACH USE | FIRST 2 HOURS | EVERY 10 HOURS | EVERY 25 HOURS | BEFORE STORAGE | | | | | | |
| MOWER | Check for Loose Fasteners | ✓ | | | | | | ✓ | | | | | |
| | Clean/Inspect Grass Catcher (If Equipped) | ✓ | ✓ | | | | | ✓ | | | | | |
| | Clean Lawn Mower | | ✓ | | | | | ✓ | | | | | |
| | Clean Under Drive Cover (Self-Propelled Mowers) | | | | ✓ | | | | | | | | |
| | Check/Sharpen/Replace Blade | | | | | ✓ ³ | | | | | | | |
| | Lubrication Chart | | | | | ✓ | | ✓ | | | | | |
| | Clean Battery/Recharge (Electric Start Mowers) | | | | | ✓ | | ✓ ⁴ | | | | | |
| ENGINE | Check Engine Oil Level | ✓ | | | | | | | | | | | |
| | Change Engine Oil | | | ✓ | | ✓ ^{1,2} | | | | | | | |
| | Clean Air Filter | | | | | ✓ ² | | | | | | | |
| | Inspect Muffler | | | | | ✓ | | | | | | | |
| | Clean or Replace Spark Plug | | | | | | | ✓ | | | | | |
| | Replace Air Filter Paper Cartridge | | | | | | | ✓ ² | | | | | |

- 1 - Change more often when operating under a heavy load or in high ambient temperatures.
- 2 - Service more often when operating in dirty or dusty conditions.
- 3 - Replace blades more often when mowing in sandy soil.
- 4 - Charge 48 hours at end of season.

GENERAL RECOMMENDATIONS

The warranty on this lawn mower does not cover items that have been subjected to operator abuse or negligence. To receive full value from the warranty, operator must maintain mower as instructed in this manual.

Some adjustments will need to be made periodically to properly maintain your unit.

All adjustments in the Service and Adjustments section of this manual should be checked at least once each season.

- Once a year, replace the spark plug, replace air filter element and check blade for wear. A new spark plug and clean/new air filter element assures proper air-fuel mixture and helps your engine run better and last longer.
- Follow the maintenance schedule in this manual.

BEFORE EACH USE

- Check engine oil level.
- Check for loose fasteners.

LUBRICATION

Keep unit well lubricated (See "LUBRICATION CHART").

LUBRICATION CHART

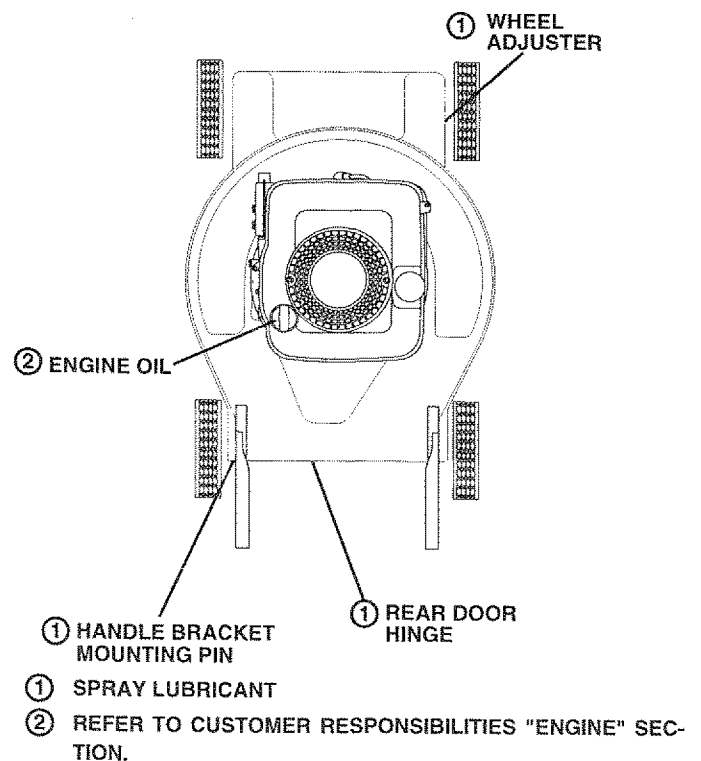

IMPORTANT: DO NOT OIL OR GREASE PLASTIC WHEEL BEARINGS. VISCOUS LUBRICANTS WILL ATTRACT DUST AND DIRT THAT WILL SHORTEN THE LIFE OF THE SELF LUBRICATING BEARINGS. IF YOU FEEL THEY MUST BE LUBRICATED, USE ONLY A DRY, POWDERED GRAPHITE TYPE LUBRICANT SPARINGLY.

CUSTOMER RESPONSIBILITIES

LAWN MOWER

Always observe safety rules when performing any maintenance.

TIRES

- Keep tires free of gasoline, oil, or insect control chemicals which can harm rubber.
- Avoid stumps, stones, deep ruts, sharp objects and other hazards that may cause tire damage.

BLADE CARE

For best results, mower blade must be kept sharp. Replace bent or damaged blades.

TO REMOVE BLADE (See Fig. 11)

- Disconnect spark plug wire from spark plug and place wire where it cannot come in contact with spark plug.
- Turn lawn mower on its side. Make sure air filter and carburetor are up.
- Use a wood block between blade and mower housing to prevent blade from turning when removing blade bolt.
- Protect your hands with gloves and/or wrap blade with heavy cloth.
- Remove blade bolt by turning counter-clockwise. Use a 9/16" box or open-end wrench.
- Remove blade and attaching hardware (bolt, lock washer and hardened washer).

NOTE: Remove the blade adapter and check the key inside hub of blade adapter. The key must be in good condition to work properly. Replace adapter if damaged.

TO REPLACE BLADE (See Fig. 11)

- Position the blade adapter on the engine crankshaft. Be sure key in adapter and crankshaft keyway are aligned.
- Position blade on the blade adapter aligning the two (2) holes in the blade with the raised lugs on the adapter.
- Be sure the trailing edge of blade (opposite sharp edge) is up toward the engine.
- Install the blade bolt with the lock washer and hardened washer into blade adapter and crankshaft.
- Use block of wood between blade and lawn mower housing and tighten the blade bolt, turning clockwise.
- The recommended tightening torque is 35-40 ft. lbs.

IMPORTANT: BLADE BOLT IS GRADE 8 HEAT TREATED.

NOTE: We do not recommend sharpening blade - but if you do, be sure the blade is balanced.

TO SHARPEN BLADE

Care should be taken to keep the blade balanced. An unbalanced blade will cause eventual damage to lawn mower or engine.

- The blade can be sharpened with a file or on a grinding wheel. Do not attempt to sharpen while on the mower.
- To check blade balance, drive a nail into a beam or wall. Leave about one inch of the straight nail exposed. Place center hole of blade over the head of the nail. If blade is balanced, it should remain in a horizontal position. If either end of the blade moves downward, sharpen the heavy end until the blade is balanced.

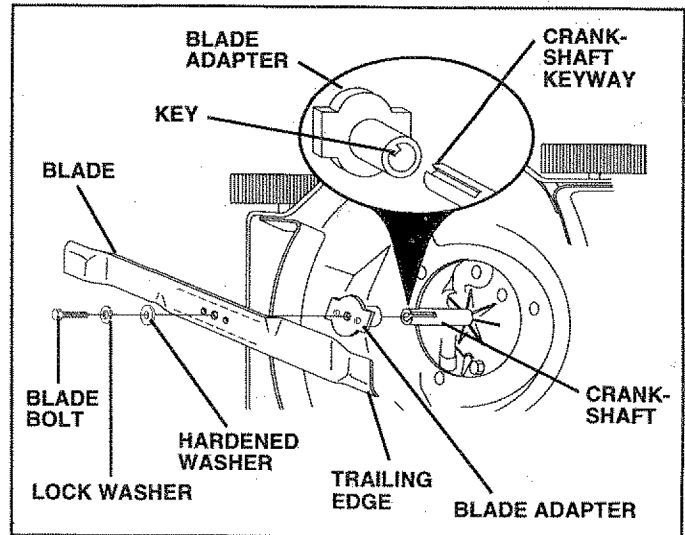

FIG. 11

GRASS CATCHER

(If purchased as an accessory)

- The grass catcher may be hosed with water, but must be dry when used.
- Check your grass catcher often for damage or deterioration. Through normal use it will wear. If catcher needs replacing, replace only with a manufacturer approved replacement catcher. Give the lawn mower model number when ordering.

DRIVE WHEELS

Check front drive wheels each time before you mow to be sure they move freely.

The wheels not turning freely means trash, grass cuttings, etc. are in the drive wheel area and must be cleaned to free drive wheels.

If necessary to clean the drive wheels, check both front wheels.

- Remove hubcaps, hairpin cotters and washers.
- Remove wheels from wheel adjusters.
- Remove any trash or grass cuttings from inside the dust cover, pinion and/or drive wheel gear teeth.
- Put wheels back in place.
- If after cleaning, the drive wheels do not turn freely, contact your nearest authorized service center.

GEAR CASE

- To keep your drive system working properly, the gear case and area around the drive should be kept clean and free of trash build-up. Clean under the drive cover twice a season.
- The gear case is filled with lubricant to the proper level at the factory. The only time the lubricant needs attention is if service has been performed on the gear case.
- If lubricant is required, use only Texaco Starplex Premium 1 Grease, Part No. 750355. Do not substitute.

CUSTOMER RESPONSIBILITIES

ENGINE

LUBRICATION

Use only high quality detergent oil rated with API service classification SF or SG. Select the oil's SAE viscosity grade according to your expected operating temperature.

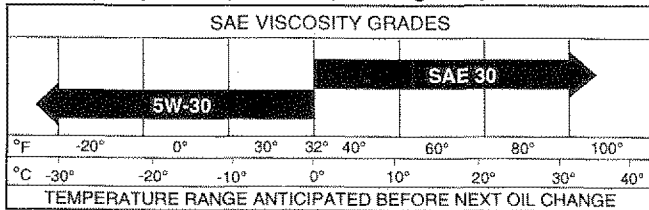

NOTE: Although multi-viscosity oils (5W30, 10W30 etc.) improve starting in cold weather, these multi-viscosity oils will result in increased oil consumption when used above 32°F. Check your engine oil level more frequently to avoid possible engine damage from running low on oil.

Change the oil after the first two hours of operation and every 25 hours thereafter or at least once a year if the lawn mower is not used for 25 hours in one year.

Check the crankcase oil level before starting the engine and after each five (5) hours of continuous use. Tighten oil plug securely each time you check the oil level.

TO CHANGE ENGINE OIL (See Fig. 12)

NOTE: Before tipping lawn mower to drain oil, drain fuel tank by running engine until fuel tank is empty.

- Disconnect spark plug wire from spark plug and place wire where it cannot come in contact with spark plug.
- Remove engine oil cap; lay aside on a clean surface.
- Tip lawn mower on its side and drain oil into a suitable container. Rock lawn mower back and forth to remove any oil trapped inside of engine.
- Wipe off any spilled oil on lawn mower and on side of engine.
- Fill engine with oil. Fill only to the "FULL" line on the dipstick. **DO NOT OVER FILL.**
- Replace engine oil cap.
- Reconnect spark plug wire to spark plug.

AIR FILTER

Your engine will not run properly and may be damaged by using a dirty air filter.

Replace the air filter every year, more often if you mow in very dusty, dirty conditions.

TO CLEAN AIR FILTER (See Fig. 13)

- Loosen screw and tilt cover to remove.
- Carefully remove cartridge.
- Clean by gently tapping on a flat surface. If very dirty, replace cartridge.



CAUTION: Petroleum solvents, such as kerosene, are not to be used to clean cartridge. They may cause deterioration of the cartridge. Do not oil cartridge. Do not use pressurized air to clean or dry cartridge.

- Install cartridge, then replace cover making sure the tabs are aligned with the slots in the back plate. Fasten screw securely.

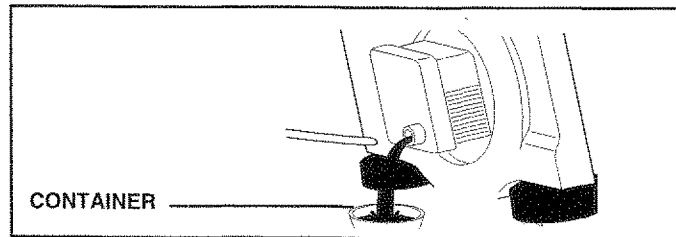

CONTAINER

FIG. 12

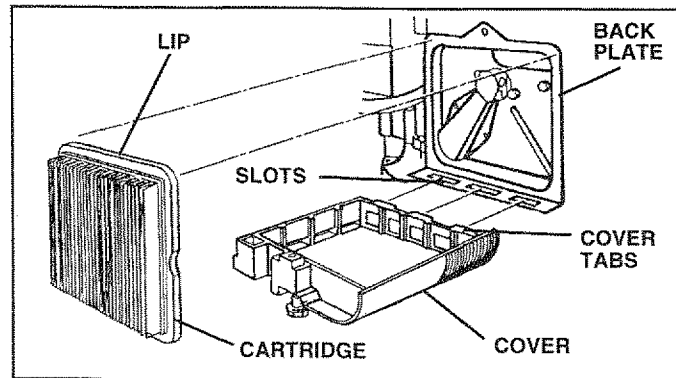

FIG. 13

MUFFLER

Inspect and replace corroded muffler as it could create a fire hazard and/or damage.

SPARK PLUG

Change your spark plug each year to make your engine start easier and run better. Set spark plug gap at .030 inch.

CLEANING

IMPORTANT: FOR BEST PERFORMANCE, KEEP MOWER HOUSING FREE OF BUILT-UP GRASS AND TRASH. CLEAN THE UNDERSIDE OF YOUR MOWER AFTER EACH USE.



CAUTION: Disconnect spark plug wire from spark plug and place wire where it cannot come in contact with the spark plug.

- Turn lawn mower on its side. Make sure air filter and carburetor are up. Clean the underside of your lawn mower by scraping to remove build-up of grass and trash.
- Clean engine often to keep trash from accumulating. A clogged engine runs hotter and shortens engine life.
- Keep finished surfaces and wheels free of all gasoline, oil, etc.
- We do not recommend using a garden hose to clean lawn mower unless the electrical system, muffler, air filter and carburetor are covered to keep water out. Water in engine can result in shortened engine life.

CLEAN UNDER DRIVE COVER

Clean under drive cover at least twice a season. Scrape underside of cover with putty knife or similar tool to remove any build-up of trash or grass on underside of drive cover.

SERVICE AND ADJUSTMENTS



CAUTION: BEFORE PERFORMING ANY SERVICE OR ADJUSTMENTS:

- Release control bar.
- Make sure the blade and all moving parts have completely stopped.
- Disconnect spark plug wire from spark plug and place where it cannot come in contact with plug.

LAWN MOWER

TO ADJUST CUTTING HEIGHT

See "TO ADJUST CUTTING HEIGHT" in the Operation section of this manual.

REAR DEFLECTOR

The rear deflector, attached between the rear wheels of your lawn mower, is provided to minimize the possibility that objects will be thrown out the rear of the lawn mower into the operator's mowing position. If the rear deflector becomes damaged, it should be replaced.

TO REMOVE/REPLACE DRIVE BELT

(See Fig. 14)

- Remove drive cover. Remove belt by pushing down on gear case pulley.
- Turn lawn mower on its side with carburetor and fuel cap up.
- Remove blade.
- Remove debris shield.
- Remove belt from engine pulley on crankshaft.
- Install new belt by reversing above steps.
- Always use factory approved belt to assure fit and long life.

TO ADJUST CARBURETOR (See Fig. 15)

Minor carburetor adjustments may be required to compensate for differences in fuel, temperature, altitude or load. The air cleaner and air cleaner cover must be assembled to carburetor when running.

INITIAL ADJUSTMENT-

With the engine not running, gently turn idle mixture screw clockwise until it just closes. Screw may be damaged by turning it in too far.

Next open the screw one turn counter-clockwise. This initial adjustment will permit the engine to be started and warmed up (approximately 5 minutes) prior to final adjustment.

NOTE: Do not adjust top no load adjusting screw. It was pre-set at the factory.

FINAL ADJUSTMENT-

Place engine speed control lever in idle or slow (🛑) position. Adjust idle RPM by turning idle speed adjusting screw to obtain 1700 RPM. Next, turn idle mixture screw in (clockwise - lean mixture) until engine just starts to slow. Then turn idle mixture screw out (counter-clockwise - rich mixture) until engine runs unevenly. Now turn idle mixture screw midway between rich and lean. Engine should accelerate smoothly. If engine does not accelerate properly, the carburetor should be readjusted, usually to a richer mixture, by turning the idle mixture screw counter-clockwise 1/8 turn more.

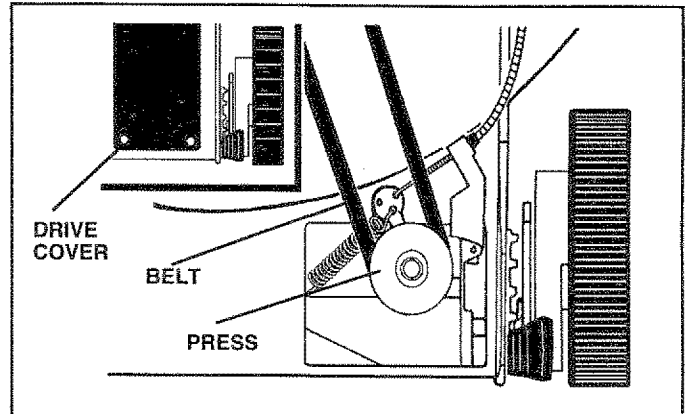

FIG. 14

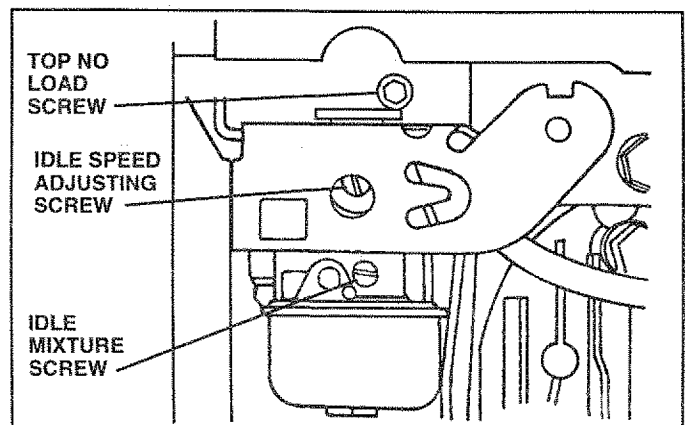

FIG. 15

IMPORTANT: NEVER TAMPER WITH THE ENGINE GOVERNOR, WHICH IS FACTORY SET FOR PROPER ENGINE SPEED. OVERSPEEDING THE ENGINE ABOVE THE FACTORY HIGH SPEED SETTING CAN BE DANGEROUS. IF YOU THINK THE ENGINE-GOVERNED HIGH SPEED NEEDS ADJUSTING, CONTACT YOUR NEAREST AUTHORIZED SERVICE CENTER, WHICH HAS PROPER EQUIPMENT AND EXPERIENCE TO MAKE ANY NECESSARY ADJUSTMENTS.

SERVICE AND ADJUSTMENTS

TO ADJUST HANDLE (See Figs. 16 Thru 18)

Your lawn mower handle can be raised or lowered for your mowing comfort. Four (4) positions are available: high, medium high, medium low and low. Handles are shipped mounted in the medium low position.

- To change from medium low to medium high position, the upper and lower handle sections will have to be turned over (See Fig. 16B).
- Remove the controls and operator presence control bar from the upper handle.
- Remove the starter rope guide from the lower handle.
- Remove hairpin cotters.
- Disconnect the lower handle from the handle brackets (See Fig. 18).
- Turn the handle over and reassemble the hairpin cotters that have been removed.
- Reassemble the starter rope guide.
- Reassemble the controls and the operator presence control bar to the upper handle.



CAUTION: The operator presence control bar must pivot freely to permit blade brake engagement when control bar is released. Do not over tighten the fasteners holding the controls to the upper handle.

- To change from medium low to high position only the upper handle section will have to be turned over (See Fig. 17A).
- To change from medium low to low position, only the lower handle section will have to be turned over (See Fig. 17B).

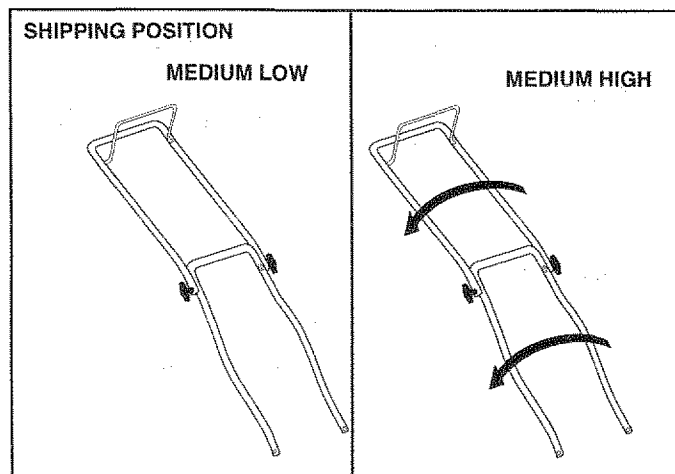

FIG. 16A

FIG. 16B

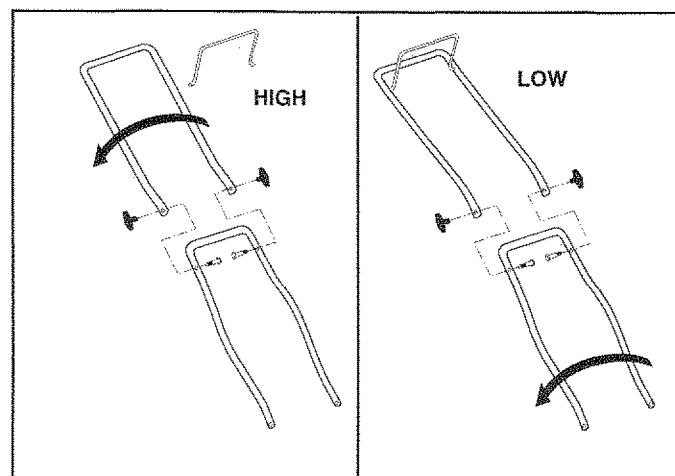

FIG. 17

FIG. 17B

ENGINE

ENGINE SPEED

Your engine speed has been factory set. Do not attempt to increase engine speed or it may result in personal injury. If you believe that the engine is running too fast or too slow, take your lawn mower to an authorized service center for repair and adjustment.

CARBURETOR

Your carburetor has a non-adjustable fixed main jet for mixture control. If your engine does not operate properly due to suspected carburetor problems, take your lawn mower to an authorized service center for repair and/or adjustment.

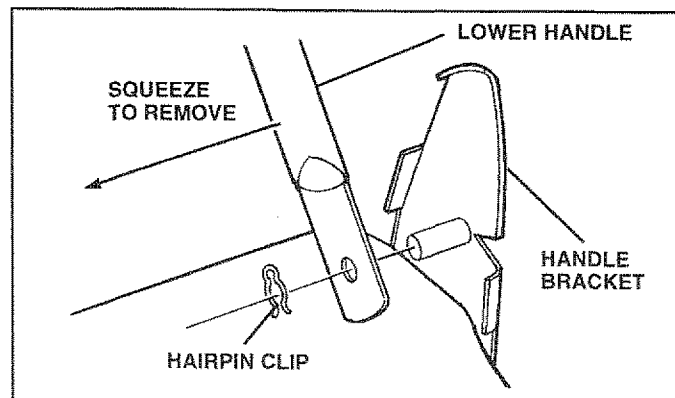

FIG. 18

STORAGE

Immediately prepare your lawn mower for storage at the end of the season or if the unit will not be used for 30 days or more.

LAWN MOWER

When lawn mower is to be stored for a period of time, clean it thoroughly remove all dirt, grease, leaves, etc. Store in a clean, dry area.

- Clean entire lawn mower (See "CLEANING" in the Customer Responsibilities section of this manual).
- Lubricate as shown in the Customer Responsibilities section of this manual.
- Be sure that all nuts, bolts, screws, and pins are securely fastened. Inspect moving parts for damage, breakage and wear. Replace if necessary.
- Touch up all rusted or chipped paint surfaces; sand lightly before painting.

HANDLE (See Fig. 19)

You can fold your lawn mower handle for storage.

- Squeeze the bottom ends of the lower handle toward each other until the lower handle clears the handle bracket, then move handle forward.
- Loosen upper handle mounting bolts enough to allow upper handle to be folded back.

IMPORTANT: WHEN FOLDING THE HANDLE FOR STORAGE OR TRANSPORTATION, BE SURE TO FOLD THE HANDLE AS SHOWN OR YOU MAY DAMAGE THE CONTROL CABLES.

- When setting up your handle from the storage position, the lower handle will automatically lock into the mowing position.

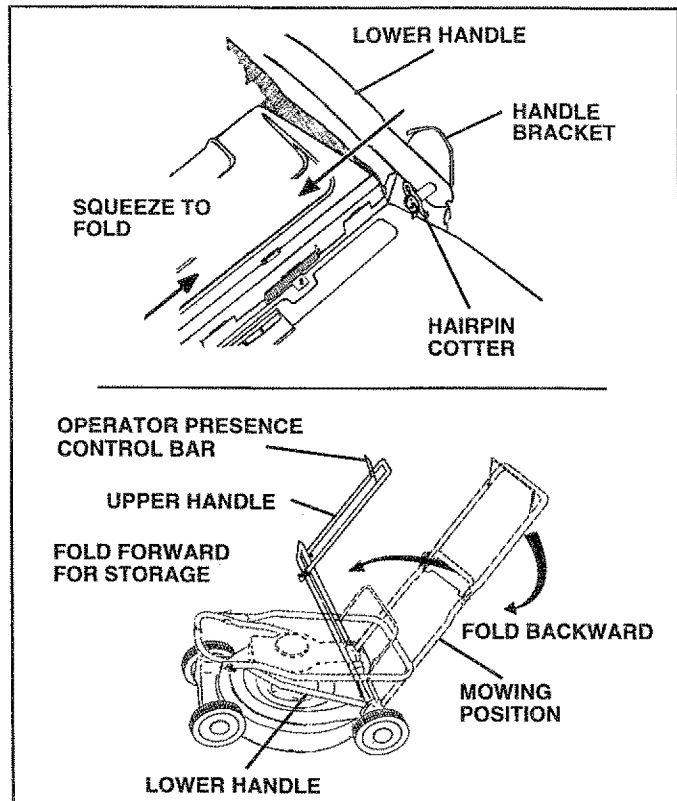

FIG. 19

ENGINE FUEL SYSTEM

IMPORTANT: IT IS IMPORTANT TO PREVENT GUM DEPOSITS FROM FORMING IN ESSENTIAL FUEL SYSTEM PARTS SUCH AS CARBURETOR, FUEL FILTER, FUEL HOSE, OR TANK DURING STORAGE. ALSO, EXPERIENCE INDICATES THAT ALCOHOL BLENDED FUELS (CALLED GASOHOL OR USING ETHANOL OR METHANOL) CAN ATTRACT MOISTURE WHICH LEADS TO SEPARATION AND FORMATION OF ACIDS DURING STORAGE. ACIDIC GAS CAN DAMAGE THE FUEL SYSTEM OF AN ENGINE WHILE IN STORAGE.

- Drain the fuel tank.
- Start the engine and let it run until the fuel lines and carburetor are empty.
- Never use engine or carburetor cleaner products in the fuel tank or permanent damage may occur.
- Use fresh fuel next season.

NOTE: Fuel stabilizer is an acceptable alternative in minimizing the formation of fuel gum deposits during storage. Add stabilizer to gasoline in fuel tank or storage container. Always follow the mix ratio found on stabilizer container. Run engine at least 10 minutes after adding stabilizer to allow the stabilizer to reach the carburetor. Do not drain the gas tank and carburetor if using fuel stabilizer.

ENGINE OIL

Drain oil (with engine warm) and replace with clean engine oil. (See "ENGINE" in the Customer Responsibilities section of this manual).

CYLINDER

- Remove spark plug.
- Pour one ounce (29 ml) of oil through spark plug hole into cylinder.
- Pull starter handle slowly a few times to distribute oil.
- Replace with new spark plug.

OTHER

- Do not store gasoline from one season to another.
- Replace your gasoline can if your can starts to rust. Rust and/or dirt in your gasoline will cause problems.
- If possible, store your unit indoors and cover it to give protection from dust and dirt.
- Cover your unit with a suitable protective cover that does not retain moisture. Do not use plastic. Plastic cannot breathe which allows condensation to form and will cause your unit to rust.

IMPORTANT: NEVER COVER MOWER WHILE ENGINE AND EXHAUST ARE STILL WARM.



CAUTION: Never store the lawn mower with gasoline in the tank inside a building where fumes may reach an open flame or spark. Allow the engine to cool before storing in any enclosure.

SERVICE NOTES

TROUBLESHOOTING POINTS

| PROBLEM | CAUSE | CORRECTION |
|--|---|--|
| Does not start | <ol style="list-style-type: none"> 1. Dirty air filter. 2. Out of fuel. 3. Stale fuel. 4. Water in fuel. 5. Spark plug wire is disconnected. 6. Bad spark plug. 7. Loose blade or broken blade adapter. 8. Control bar in released position 9. Control bar defective | <ol style="list-style-type: none"> 1. Clean/replace air filter. 2. Fill fuel tank. 3. Drain tank and refill with fresh clean fuel. 4. Drain fuel tank and carburetor and refill tank with fresh gasoline. 5. Connect wire to plug. 6. Replace spark plug. 7. Tighten blade bolt or replace blade adapter. 8. Depress control bar to handle. 9. Replace control bar. |
| Loss of power | <ol style="list-style-type: none"> 1. Rear of lawn mower housing/blade dragging in heavy grass. 2. Cutting too much grass. 3. Dirty air filter. 4. Buildup of grass, leaves and trash under mower. 5. Too much oil in engine. 6. Walking speed too fast. | <ol style="list-style-type: none"> 1. Set in "Higher Cut" position. 2. Set in "Higher Cut" position. 3. Clean/replace air filter. 4. Clean underside of mower housing. 5. Check oil level. 6. Cut at slower walking speed. |
| Poor cut - uneven | <ol style="list-style-type: none"> 1. Worn, bent or loose blade. 2. Wheel heights uneven. 3. Low engine speed. 4. Buildup of grass, leaves, and trash under mower. | <ol style="list-style-type: none"> 1. Replace blade. Tighten blade bolt. 2. Set all wheels at same height. 3. Set engine speed control in fast position. 4. Clean underside of mower housing. |
| Excessive vibration | <ol style="list-style-type: none"> 1. Worn, bent or loose blade. 2. Bent engine crankshaft. | <ol style="list-style-type: none"> 1. Replace blade. Tighten blade bolt. 2. Contact authorized service center/department. |
| Starter rope hard to pull | <ol style="list-style-type: none"> 1. Engine flywheel brake is on when control bar is released. 2. Bent engine crankshaft 3. Blade adapter broken. 4. Blade dragging in grass. | <ol style="list-style-type: none"> 1. Depress control bar to upper handle before pulling starter rope. 2. Contact authorized service center/department. 3. Replace blade adapter. 4. Move lawn mower to cut grass or to hard surface to start engine. |
| Loss of drive | <ol style="list-style-type: none"> 1. Drive wheels not turning with drive control engaged. 2. Belt not driving. | <ol style="list-style-type: none"> 1. Adjust or replace drive control cable, if broken. 2. Put belt on pulleys or replace belts if broken. |
| Grass catcher not filling (if so equipped) | <ol style="list-style-type: none"> 1. Cutting height too low. 2. Lift on blade worn off. 3. Catcher not venting air. 4. Low engine speed. | <ol style="list-style-type: none"> 1. Raise cutting height. 2. Replace blade. 3. Clean grass catcher. 4. Set engine speed control in fast position. |
| Hard to push | <ol style="list-style-type: none"> 1. Grass is too high or wheel height is too low. 2. Rear of lawn mower housing/blade dragging in grass. 3. Grass catcher too full. 4. Handle height position not right for you. | <ol style="list-style-type: none"> 1. Raise cutting height. 2. Raise rear of lawn mower housing one (1) setting higher. 3. Empty grass catcher. 4. Adjust handle height to suit. |

REPAIR PARTS

ROTARY LAWN MOWER MODEL NUMBER 917.372833

20

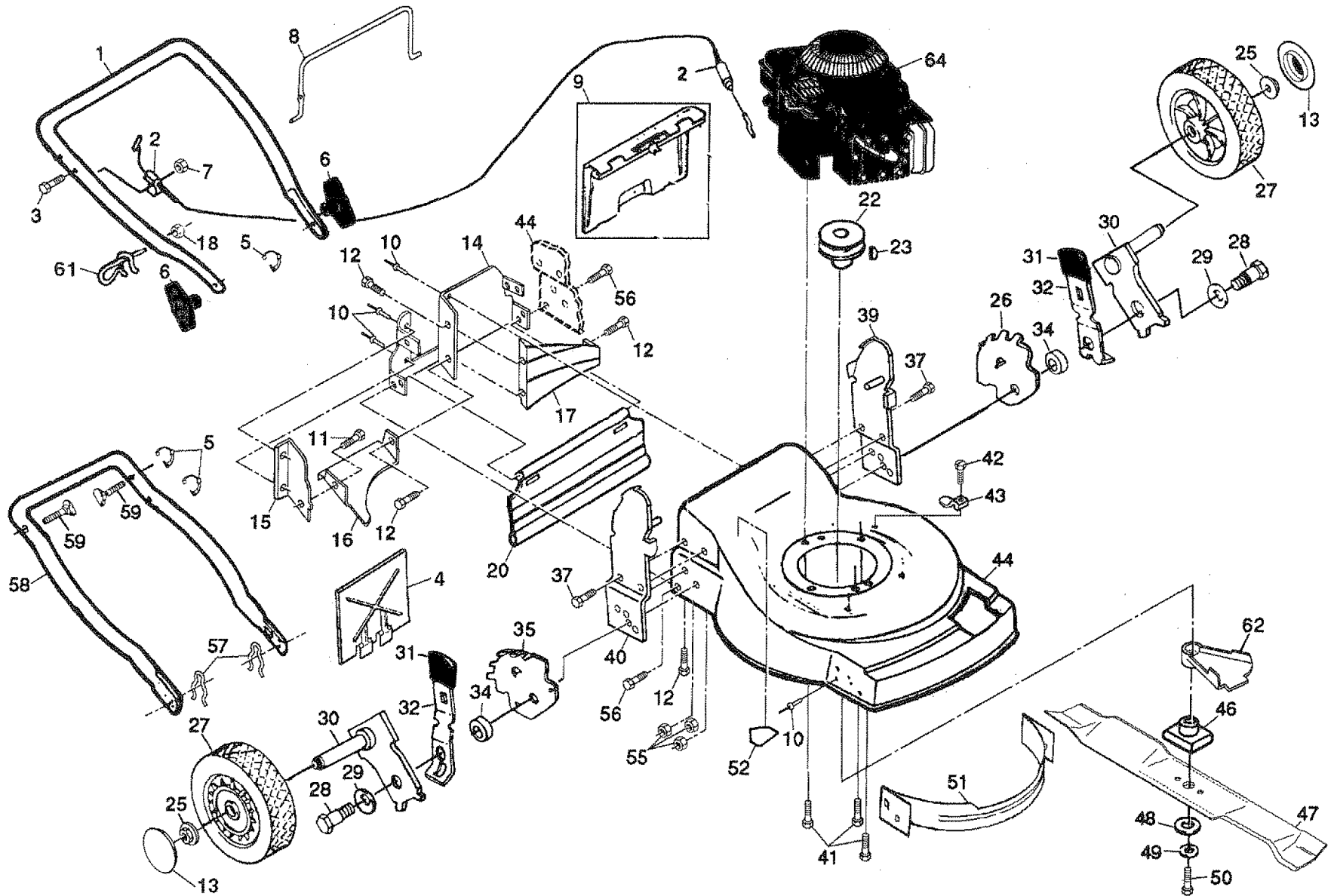

REPAIR PARTS

ROTARY LAWN MOWER MODEL NUMBER 917.372833

| KEY NO. | PART NO. | DESCRIPTION | KEY NO. | PART NO. | DESCRIPTION |
|---------|------------|---------------------------------------|---------|------------|---|
| 1 | 145646X479 | Upper Handle | 37 | 55187 | Thread Cutting Screw w/Sems 5/16-18 x 3/4 |
| 2 | 130861 | Engine Zone Control Cable | 39 | 140629X479 | Handle Bracket Assembly (Left) |
| 3 | 74350424 | Hex Head Screw 1/4-20 x 1-1/2 | 40 | 140628X479 | Handle Bracket Assembly (Right) |
| 4 | 133170X479 | Mulcher Plate | 41 | 850998 | Hex Head Thread Rolling Screw 3/8-16 x 1-1/8 |
| 5 | 85827 | Cable Clip | 42 | 750097 | Hex Washer Head Screw #10-24 x 1/2 |
| 6 | 136376 | Handle Knob | 43 | 87930 | Guide Clip |
| 7 | STD541425 | Locknut 1/4-20 | 44 | 149070 | Lawn Mower Housing (Incl. Key #14, 15, 51 & 52) |
| 8 | 145793 | Control Bar | 46 | 851514 | Blade Adapter |
| 9 | 147612 | Rear Door Kit | 47 | 141114 | Blade 22" |
| 10 | 128415 | Pop Rivet | 48 | 851074 | Hardened Washer |
| 11 | 150050 | Self Tapping Screw #10-24 x 5/8 | 49 | 850263 | Helical Washer 3/8-24 x 1-3/8 Gr. 8 |
| 12 | STD512505 | Hex Tapping Screw w/Sems 1/4-20 x 1/2 | 50 | 851084 | Hex Head Machine Screw 3/8-24 x 1-3/8 Gr. 8 |
| 13 | 77400 | Hubcap | 51 | 700869X479 | Front Baffle |
| 14 | 700483X479 | Back Plate | 52 | 85463 | Danger Decal |
| 15 | 700365X479 | Side Baffle | 55 | 751592 | Locknut 3/8-16 |
| 16 | 133190X479 | Discharge Baffle | 56 | 88652 | Hinge Screw 1/4-20 x 1-1/4 |
| 17 | 140661X479 | Rear Baffle | 57 | 51793 | Hairpin Cotter |
| 18 | 73510400 | Keys Locknut | 58 | 84676X479 | Lower Handle |
| 20 | 140540 | Rear Skirt | 59 | 131959 | Handle Bolt |
| 22 | 85543 | Engine Pulley | 61 | 132001 | Rope Guide |
| 23 | 87677 | Hi-Pro Key #505 | 62 | 134612 | Debris Shield |
| 25 | 83923 | Hex Flange Nut | 64 | 150560 | Engine-Briggs & Stratton - Model No. 128802-0840-01 |
| 26 | 700326X007 | Wheel Adjusting Bracket (Left) | -- | 153581 | Owner's Manual (English/Spanish) |
| 27 | 146247 | Wheel | | | |
| 28 | 142748 | Shoulder Bolt 3/8-16 x 1 | | | |
| 29 | 62335 | Spring Washer | | | |
| 30 | 145935X004 | Axle Arm Assembly | | | |
| 31 | 701037 | Selector Knob | | | |
| 32 | 700331X004 | Selector Spring | | | |
| 34 | 146630 | Spacer | | | |
| 35 | 700327X007 | Wheel Adjusting Bracket (Right) | | | |

Available accessories not included with lawn mower:

| | | |
|----|-----------------|----------------------|
| -- | <u>71</u> 33303 | Clipping Deflector |
| -- | <u>71</u> 33623 | Gas Can (2.5 gal.) |
| -- | <u>71</u> 33500 | Fuel Stabilizer |
| -- | <u>71</u> 33300 | SAE 30W Oil (20 oz.) |
| -- | <u>71</u> 33417 | Dust Shield |
| -- | <u>71</u> 33316 | Mower Cover |

REPAIR PARTS

ROTARY LAWN MOWER MODEL NUMBER 917.372833

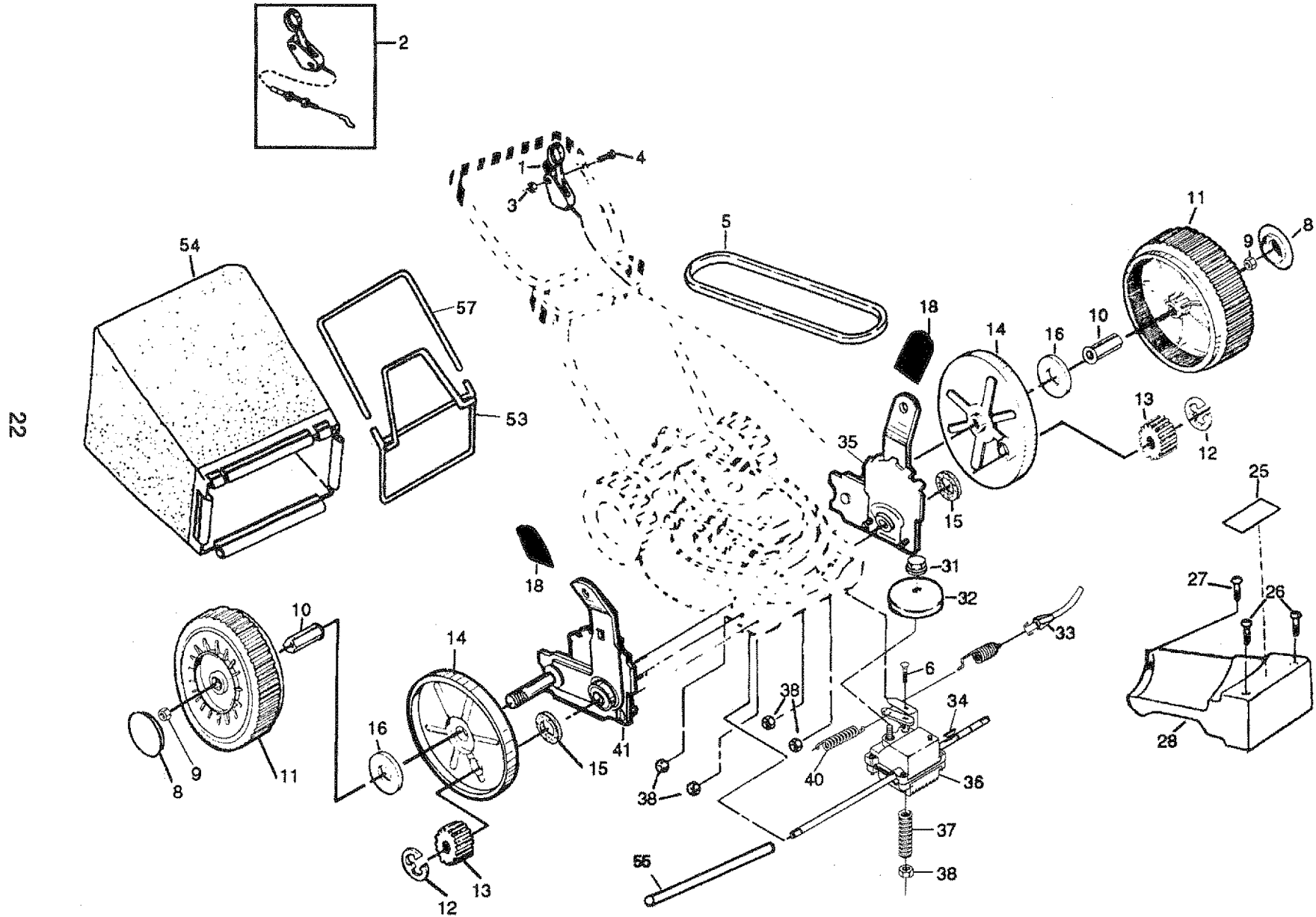

REPAIR PARTS

ROTARY LAWN MOWER MODEL NUMBER 917.372833

| KEY NO. | PART NO. | DESCRIPTION | KEY NO. | PART NO. | DESCRIPTION |
|---------|----------|-------------------------------------|---------|-----------|---------------------------------------|
| 1 | 145755 | Control Cable Assembly | 26 | 87866 | Pan Head Tapping Screw #10-24 x 2-3/4 |
| 2 | 48385 | Control Head Kit | 27 | 750097 | Hex Washer Head Screw #10-24 x 3/4 |
| 3 | 63601 | Locknut #10-24 | 28 | 137088 | Drive Cover |
| 4 | 144929 | Hex Washer Head Screw 1/4-20 x 2.12 | 31 | 132010 | Hex Flange Nut |
| 5 | 137078 | V-Belt | 32 | 137052 | Drive Pulley |
| 6 | 700875 | Carriage Bolt 1/4-20 x 2 | 33 | 48386 | Drive Control Cable Kit |
| 8 | 77400 | Hubcap | 34 | 850848 | Hi-Pro Key |
| 9 | 145212 | Washer | 35 | 146652 | Wheel Adjuster Assembly (Left) |
| 10 | 86960 | Nylon Bushing | 36 | 702511 | Gear Case Assembly |
| 11 | 700953 | Wheel & Tire Assembly | 37 | 137090 | Spring |
| 12 | 12000058 | E-Ring | 38 | STD541425 | Locknut 1/4-20 |
| 13 | 137054 | Pinion | 40 | 75192 | Spring |
| 14 | 88080 | Dust Cover | 41 | 146651 | Wheel Adjuster Assembly (Right) |
| 15 | 88118 | Felt Washer | 53 | 144747 | Frame Throat |
| 16 | 67725 | Washer 1/2 x 1-1/2 x .134 | 54 | 141245 | Grassbag Assembly |
| 18 | 701037 | Selector Knob | 55 | 86012 | Driveshaft Cover |
| 25 | 702182 | Drive Cover Decal | 57 | 144748 | Frame Tube |

REPAIR PARTS

ROTARY LAWN MOWER - - MODEL NO. 917.372833

GEAR CASE ASSEMBLY PART NUMBER 702511

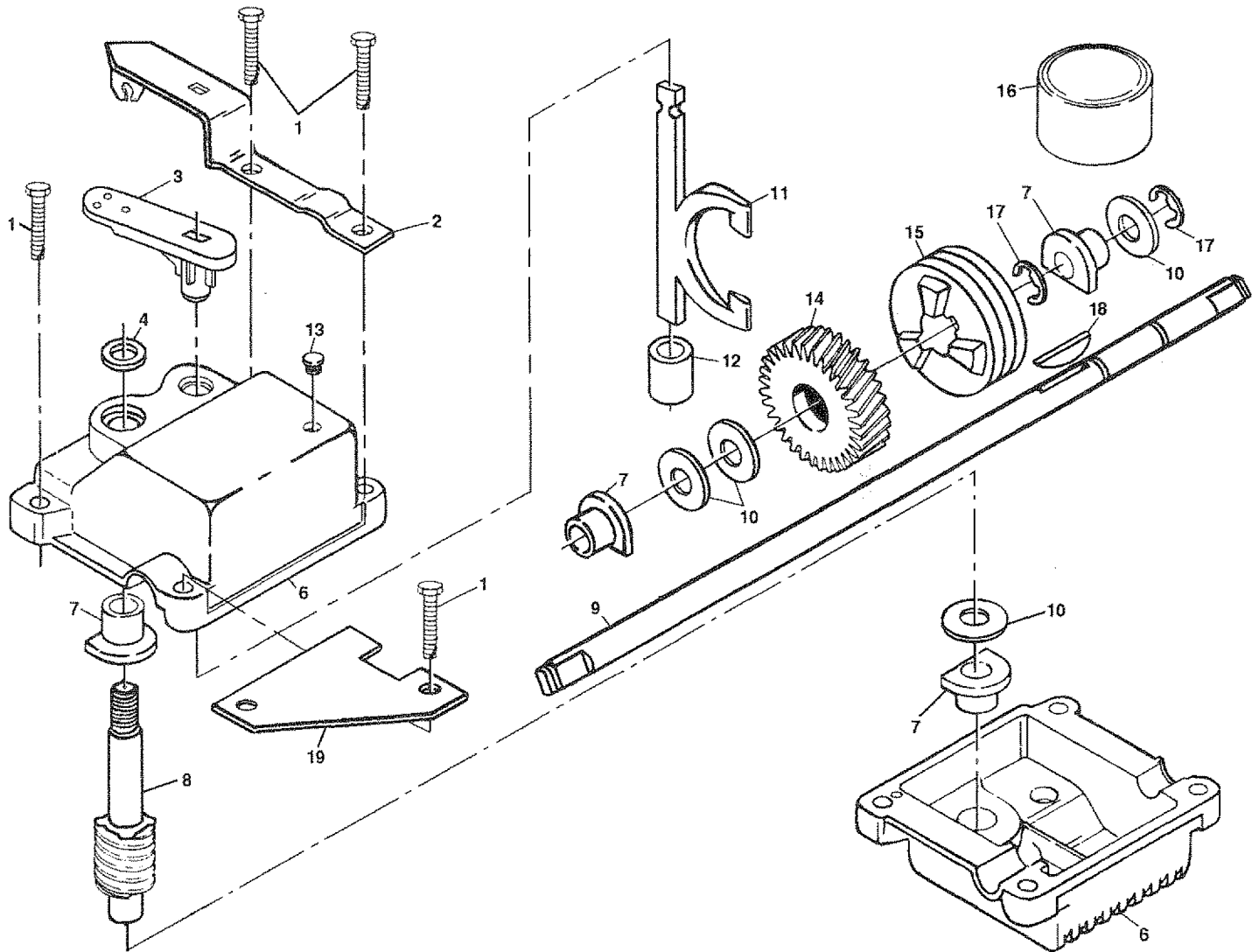

| KEY NO. | PART NO. | DESCRIPTION |
|---------|------------|--|
| 1 | 17490416 | Tapping Screw 1/4-20 x 1-1/4 |
| 2 | 137055X004 | Engagement Bracket |
| 3 | 137053 | Shifter |
| 4 | 57072 | Seal |
| 6 | 48373 | Gear Case Halves Kit (Includes Key Nos. 4, 5, and 7) |
| 7 | 77881 | Bearing |
| 8 | 137051 | Worm Shaft |
| 9 | 137074 | Drive Shaft |
| 10 | 57079 | Hardened Washer |

| KEY NO. | PART NO. | DESCRIPTION |
|---------|-----------|----------------|
| 11 | 131484 | Clutch Yoke |
| 12 | 700343 | Bushing |
| 13 | 86447 | Plug |
| 14 | 137050 | Helical Gear |
| 15 | 750436X | Clutch Jaw |
| 16 | 750369 | Grease |
| 17 | 12000003 | E-Ring |
| 18 | 850848 | Hi-Pro Key |
| 19 | 81585X004 | Spring Bracket |

NOTE: All component dimensions given in U.S. inches.
1 inch = 25.4 mm

REPAIR PARTS

CRAFTSMAN 22" ROTARY LAWN MOWER MODEL NO. 917.372833
ENGINE BRIGGS & STRATTON - MODEL NO. 128802-0840-01

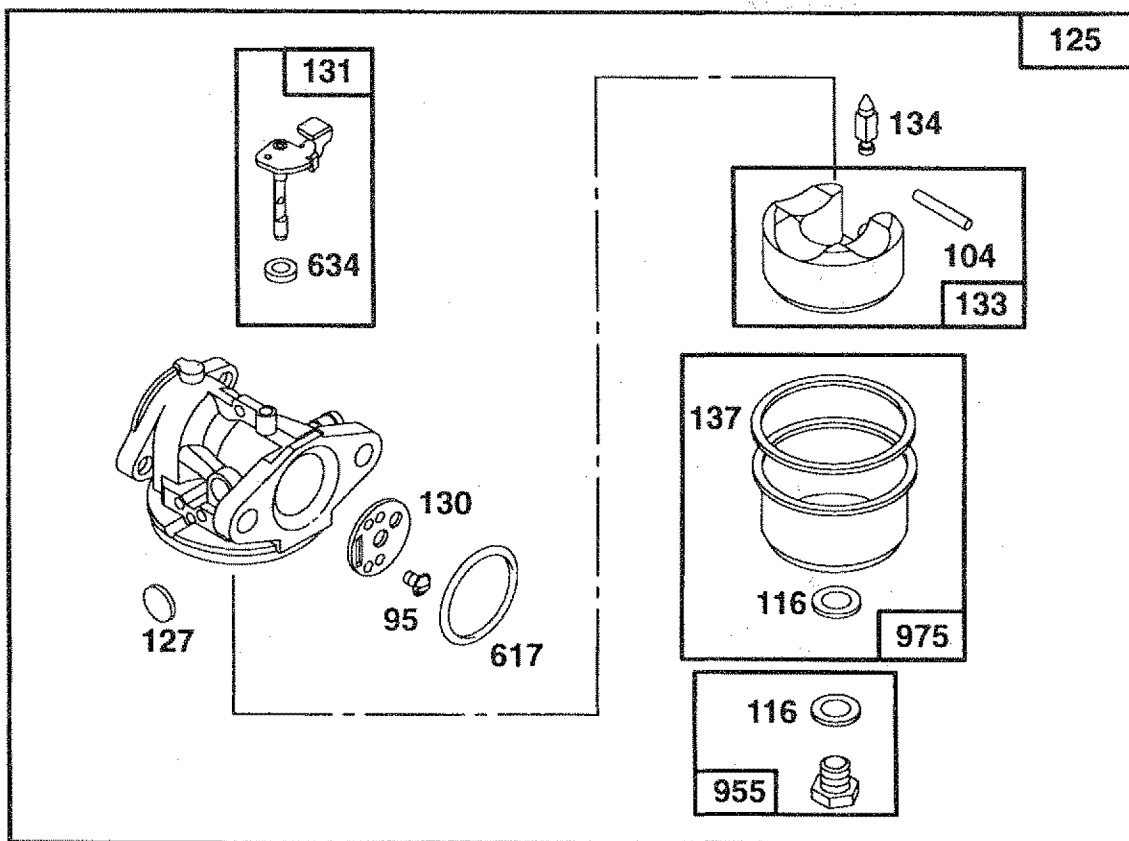
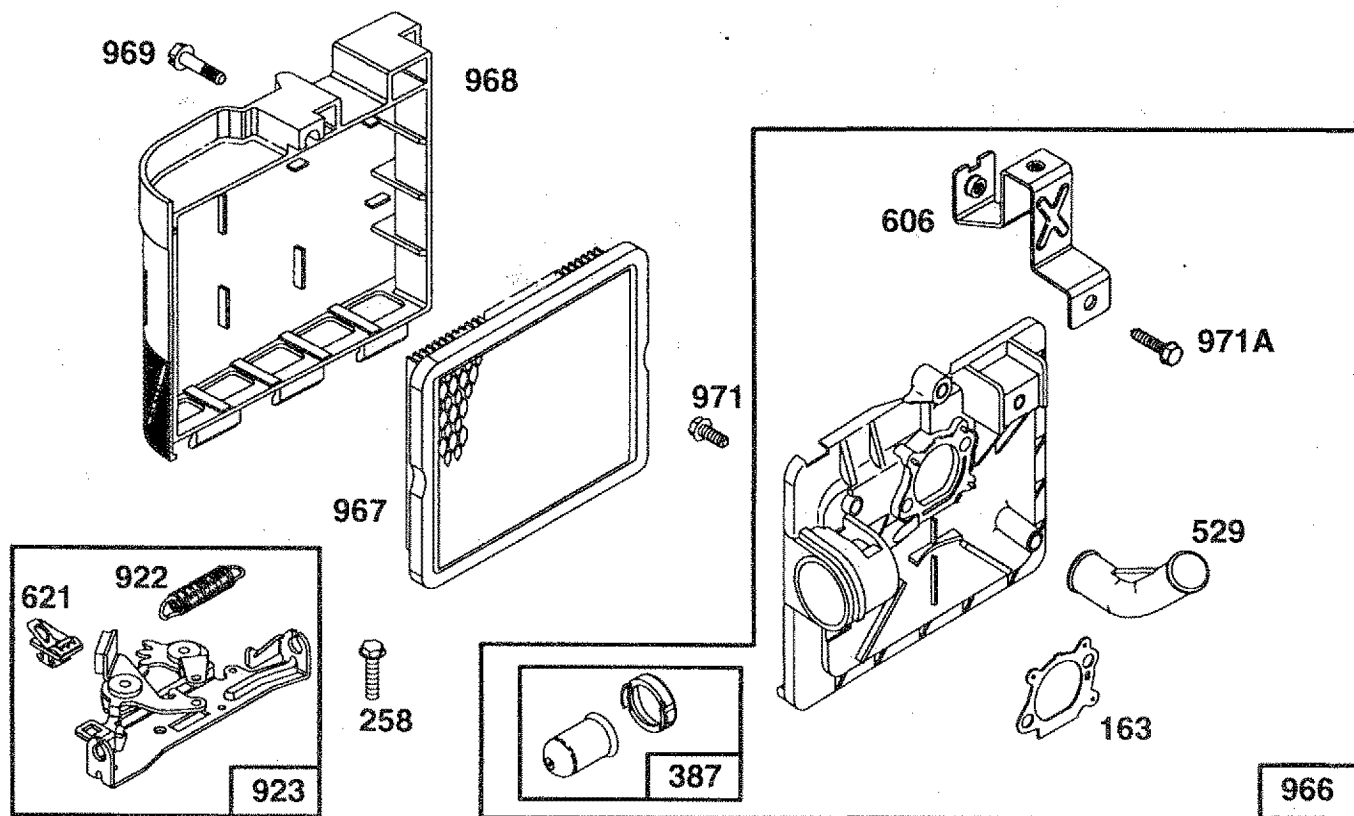

REPAIR PARTS

CRAFTSMAN 22" ROTARY LAWN MOWER MODEL NO. 917.372833
 ENGINE BRIGGS & STRATTON - MODEL NO. 128802-0840-01

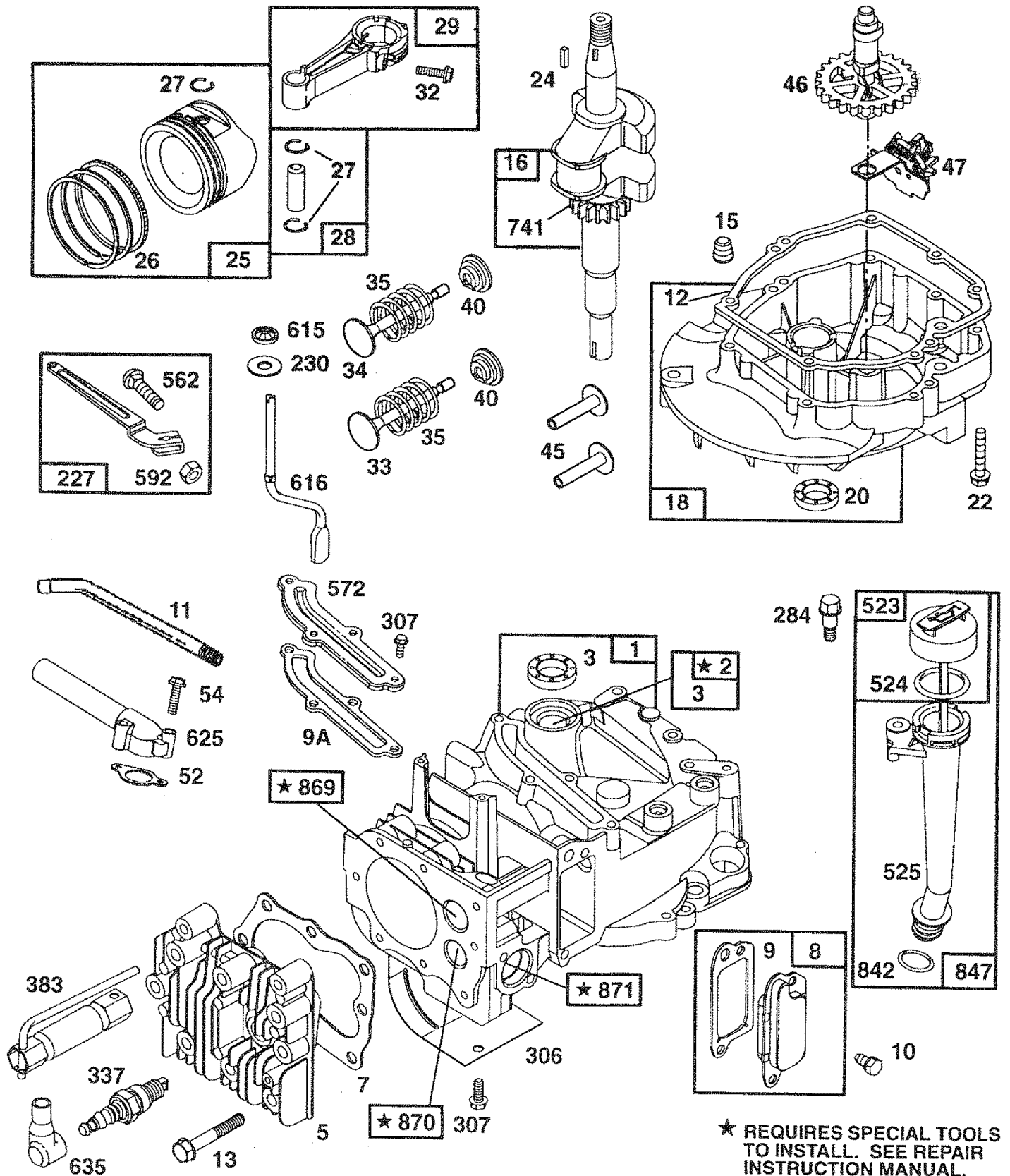

REPAIR PARTS

CRAFTSMAN 22" ROTARY LAWN MOWER MODEL NO. 917.372833
 ENGINE BRIGGS & STRATTON - MODEL NO. 128802-0840-01

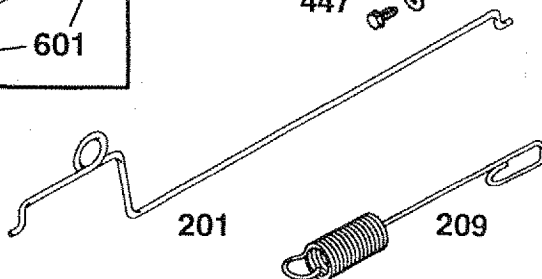
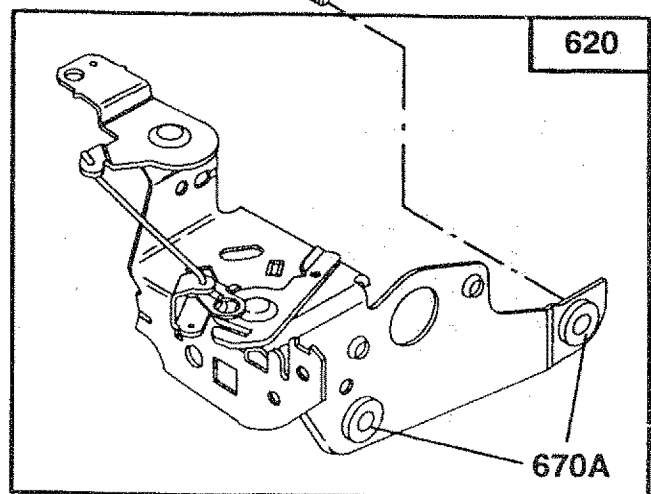
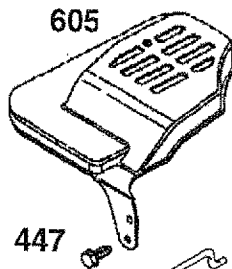
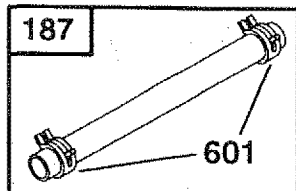
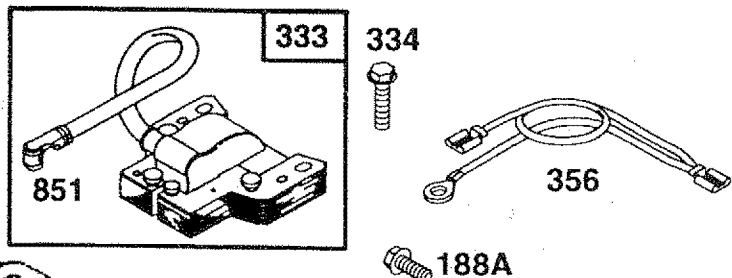
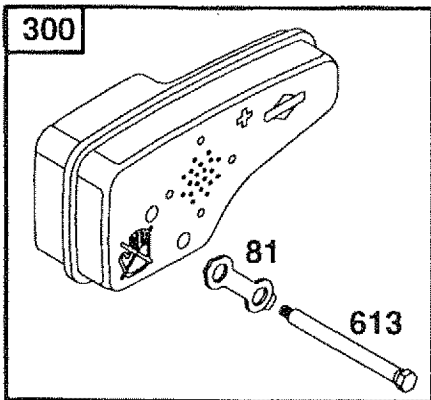
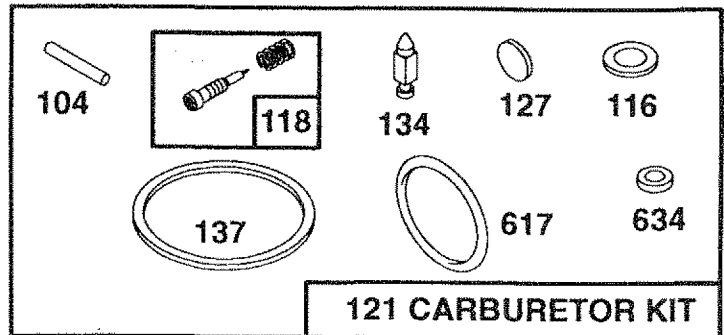
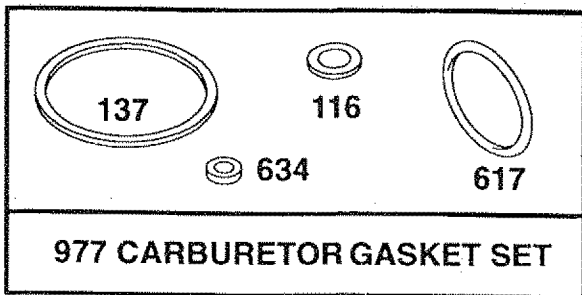
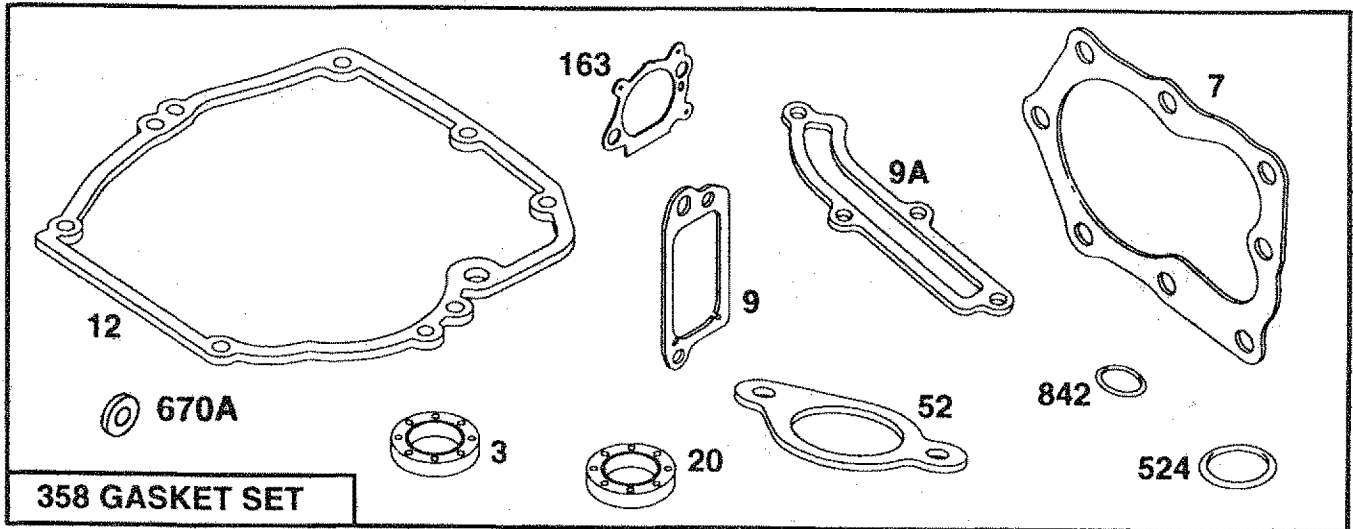

REPAIR PARTS

CRAFTSMAN 22" ROTARY LAWN MOWER MODEL NO. 917.372833
ENGINE BRIGGS & STRATTON - MODEL NO. 128802-0840-01

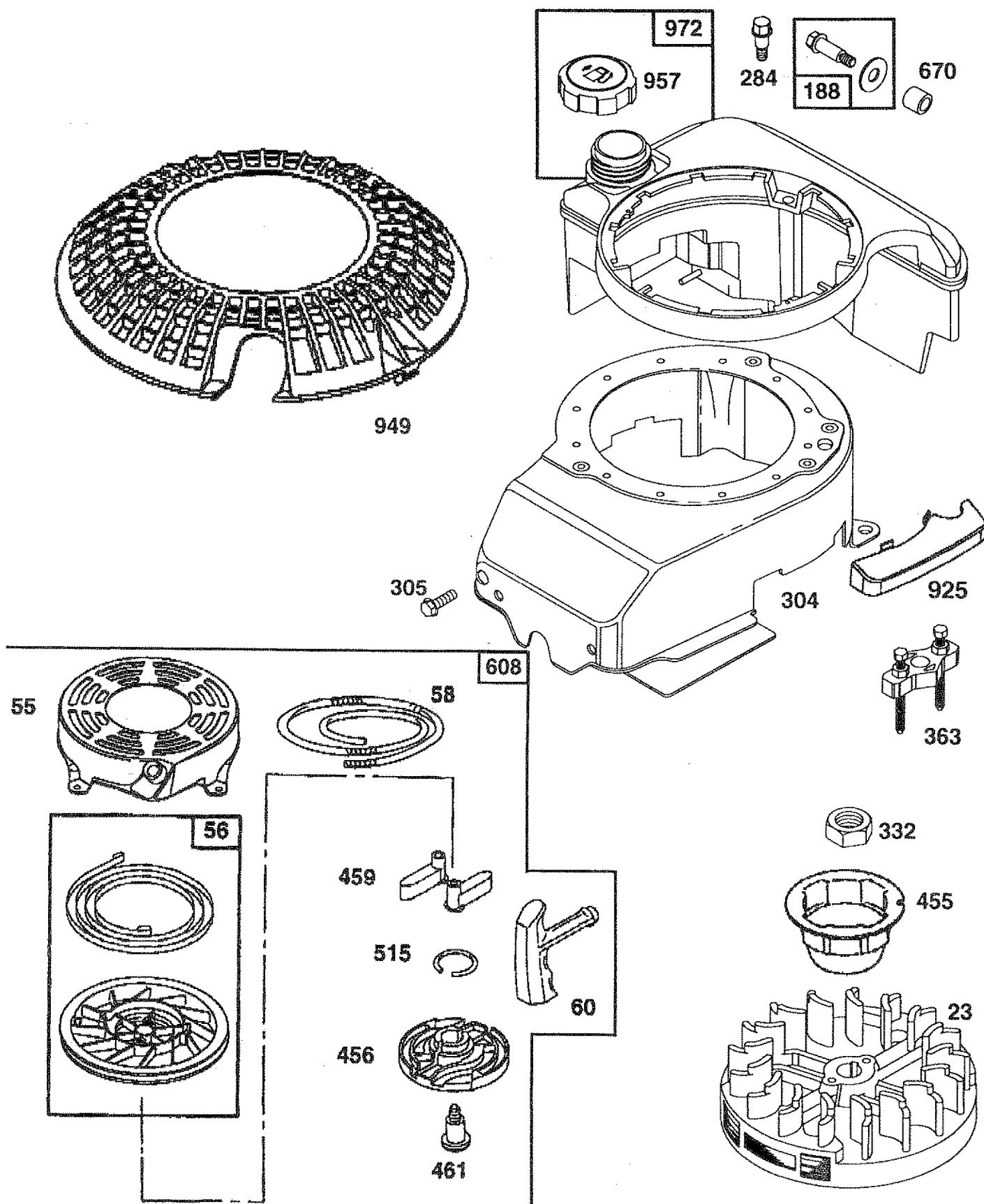

REPAIR PARTS

CRAFTSMAN 22" ROTARY LAWN MOWER MODEL NO. 917.372833

ENGINE BRIGGS & STRATTON - MODEL NO. 128802-0840-01

| KEY PART NO. NO. | DESCRIPTION | KEY PART NO. NO. | DESCRIPTION |
|------------------|--|------------------|--|
| 1 493260 | Cylinder Assembly | 47 493737 | Slinger, Oil |
| 2 293708 | Bushing, Cylinder | 52 272199 | * Gasket, Intake Elbow |
| 3 299819 | * Seal, Oil | 54 94526 | Screw, Hex Head |
| 5 214368 | Head, Cylinder | 55 497440 | Housing, Rewind Starter |
| 7 272916 | **** Gasket, Cylinder Head | 56 498144 | Pulley, Rewind Starter |
| 8 495786 | Breather Assembly | 58 280399 | Rope, Rewind Starter (Cut To 88-5/8") |
| 9 272481 | **** Gasket, Valve Cover | 60 281134 | Grip, Starter Rope |
| 9A 272238 | * Gasket, Baffle Plate | 81 223664 | Lock, Muffler Screw |
| 10 94650 | Screw, Hex Head | 95 94098 | Screw, Round Head |
| 11 231933 | Tube, Breather | 104 231371 | ** Pin, Float Hinge |
| 12 272198 | * Gasket, Crankcase | 116 - - - | *** Gasket, Sealing (Sold in Kit Only) |
| 13 94547 | Screw, Cylinder Head | 117 497466 | Jet, Main |
| 15 94720 | Plug, Oil Drain | 121 493762 | Carburetor Kit |
| 16 493362 | Crankshaft | 124 94525 | Screw, Carburetor Mounting |
| 94388 | Timing Gear Key | 125 498254 | Carburetor |
| 18 493279 | Sump, Engine | 127 - - - | ** Plug, Welch (Sold in Kit Only) |
| 20 399781 | * Seal, Oil | 130 224908 | Valve, Throttle |
| 22 94220 | Screw, Hex Head | 131 493267 | Shaft, Throttle |
| 94612 | Screw, Hex Head (Used in Hole Nearest Breather) | 133 398187 | Float, Carburetor |
| 23 492177 | Flywheel | 134 398188 | Valve, Inlet (Includes Seat) |
| 24 222698 | Key, Flywheel | 137 - - - | *** Gasket, Bowl (Sold in Kit Only) |
| 25 493262 | Piston Assembly, Standard Size | 163 272653 | * Gasket, Air Cleaner |
| 493385 | Piston Assembly, .010" Oversize | 187 492790 | Hose, Fuel |
| 493386 | Piston Assembly, .020" Oversize | 188 398540 | Screw, Hex Head |
| 493387 | Piston Assembly, .030" Oversize | 188A 94644 | Screw, Hex Head |
| 26 493261 | Ring Set, Piston, Standard Size | 201 262579 | Link, Governor |
| 493388 | Ring Set, Piston, .010" Oversize | 209 263044 | Spring, Governor |
| 493389 | Ring Set, Piston, .020" Oversize | | |
| 493390 | Ring Set, Piston, .030" Oversize | | |
| 27 26026 | Lock, Piston Pin | | |
| 28 298909 | Pin, Piston, Standard Size | | |
| 298908 | Pin, Piston, .005" Oversize | | |
| 29 490566 | Rod, Connecting | | |
| 490743 | Rod, Connecting, .020" Undersize | | |
| 32 94699 | Screw, Connecting Rod | | |
| 33 262651 | Valve, Exhaust | | |
| 34 262652 | Valve, Intake | | |
| 35 262224 | Spring, Valve | | |
| 40 93312 | Retainer, Valve Spring | | |
| 45 262204 | Tappet, Valve | | |
| 46 492830 | Gear, Cam | | |

NOTE: All component dimensions given in U.S. inches
1 inch = 25.4 mm

REPAIR PARTS

CRAFTSMAN 22" ROTARY LAWN MOWER MODEL NO. 917.372833

ENGINE BRIGGS & STRATTON - MODEL NO. 128802-0840-01

| KEY PART NO. NO. | DESCRIPTION | KEY PART NO. NO. | DESCRIPTION |
|------------------|------------------------|------------------|---|
| 227 492349 | Lever, Governor | 634 - - - | *** Washer, Shaft (Sold in Kit Only) |
| 230 67072 | Washer, Thrust | 635 66538 | Elbow, Spark Plug |
| 258 94512 | Screw, Hex Head | 670 280512 | Spacer, Fuel Tank |
| 284 94511 | Screw, Hex Head | 670A 493823 | * Spacer, Bracket |
| 300 496106 | Muffler, Exhaust | 741 262598 | Gear, Timing |
| 304 493293 | Housing, Blower | 842 280966 | * Seal, O-Ring |
| 305 94786 | Screw, Sems | 847 495263 | Tube Assembly, Oil |
| 306 224324 | Shield, Cylinder | 851 493880 | Terminal, Ignition Cable |
| 307 94515 | Screw, Hex Head | 869 213512 | Seat, Intake Valve |
| 332 92284 | Nut, Flywheel | 870 213513 | Seat, Exhaust Valve |
| 333 802574 | Armature, Magneto | 871 262001 | Guide, Exhaust Valve |
| 334 94731 | Screw, Sems | 63709 | Guide, Intake Valve |
| 337 802592 | Plug, Spark | 922 262640 | Spring, Brake |
| 356 398808 | Wire, Ground | 923 493442 | Brake Assembly |
| 358 497316 | Gasket Set | 925 281145 | Cover, Linkage |
| 363 19069 | Puller, Flywheel | 949 281136 | Guard, Finger |
| 383 89838 | Wrench, Spark Plug | 955 494870 | Screw, Fuel Bowl |
| 387 496115 | Primer, Carburetor | 957 397974 | Cap, Fuel Tank |
| 447 94013 | Screw, Hex | 966 496116 | Base, Air Cleaner |
| 455 224250 | Cup, Starter | 967 491588 | Filter, Air |
| 456 281503 | Retainer, Starter | 968 281340 | Cover, Air Cleaner |
| 459 281505 | Pawl, Ratchet | 969 94120 | Screw, Hex Head |
| 461 94943 | Screw, Shoulder | 971 94121 | Screw, Hex Head |
| 515 263073 | Spring, Retainer | 971A 94749 | Screw, Hex Head |
| 523 495264 | Cap, Oil Filler | 972 495224 | Tank, Fuel |
| 524 280393 | * Seal, Filler Tube | 975 493640 | Bowl, Float |
| 525 495265 | Tube, Oil Fill | 977 490937 | Gasket Set, Carburetor |
| 529 281299 | Grommet | 1019 496658 | Label Kit |
| 562 92613 | Bolt, Governor Lever | 1095 498258 | Gasket Set, Valve Overhaul |
| 572 224328 | Baffle, Cylinder | | |
| 592 231082 | Nut, Hex | | RPM Settings: Low: 1900-2100; High: 3000-3200 |
| 601 93053 | Clamp, Hose | | |
| 605 225103 | Bracket, Support | | * Included in Gasket Set (497316) |
| 606 224815 | Strap, Bracket | | ** Included in Carburetor Kit (493762) |
| 608 497680 | Starter, Rewind | | *** Included in both Carburetor Kit (493762), and Carburetor Gasket Set (490937) |
| Includes: | 94904 Screw, Hex | | |
| | 94908 Cond., Terminal | | |
| 613 94231 | Screw, Hex Head | | **** Included in both Gasket Set (497316), Set (497316) and Valve overhaul Gasket Set (498528). |
| 615 94474 | Fastener | | |
| 616 262578 | Crank, Governor | | |
| 617 270344 | *** Seal, Intake Elbow | | |
| 620 497203 | Bracket, Carburetor | | |
| 621 396847 | Switch, Stop | | |
| 625 281025 | Tube, Fuel Intake | | |

NOTE: All component dimensions given in U.S. inches
1 inch = 25.4 mm

SERVICE NOTES

SEARS

OWNER'S MANUAL

**MODEL NO.
917.372833**

IF YOU NEED REPAIR SERVICE OR PARTS:

FOR REPAIR SERVICE, CALL
THIS TOLL FREE NUMBER:

1-800-4-REPAIR
(1-800-473-7247)

FOR REPLACEMENT PARTS
INFORMATION AND
ORDERING, CALL THIS
TOLL FREE NUMBER:

1-800-FON-PART
(1-800-366-7278)

CRAFTSMAN®

5.5 HORSEPOWER 22" REAR DISCHARGE POWER PROPELLED ROTARY LAWN MOWER

Each lawn mower has its own model number. Each engine has its own model number.

The model number for your lawn mower will be found on a decal attached to the rear of the lawn mower housing.

The model number for your engine will be found on the blower housing of the engine.

All parts listed herein may be ordered from any Sears, Roebuck and Co. Service Center/Department and most Retail Stores.

WHEN ORDERING REPAIR PARTS, ALWAYS GIVE THE FOLLOWING INFORMATION:

- **PRODUCT - LAWN MOWER**
- **MODEL NUMBER - 917.372833**
- **ENGINE MODEL NO. - 128802, TYPE NO. 0840-01**
- **PART NUMBER**
- **PART DESCRIPTION**

Your Sears merchandise has added value when you consider Sears has service units nationwide staffed with Sears trained technicians... professional technicians specifically trained to insure that we meet our pledge to you, we service what we sell.

SERVICE NOTES

SERVICE NOTES
