

OWNER'S MANUAL

SEARS

Kenmore

OVERLOCK 3/4

MODEL 385.1564180

Dear Customer:

You have just invested in a very fine overlock. Before using your new Kenmore machine, please pause for a moment and carefully read this booklet which contains instructions on how to operate and care for your machine.

Specific instructions are given on threading, tension adjustments, cleaning, oiling, etc. This will help you obtain the best sewing results and avoid unnecessary service expense for conditions beyond our control.

Advice on the operation and care of your machine is always available at your nearest Sears Retail Store. Please remember, if you have questions about your machine or need parts and service, always mention the model number and serial number when you inquire.

Safety Cautions:

- Be sure that the electrical voltage of the wall outlet (wall receptacle) is the same as the rated voltage of the motor.
- Disconnect the power supply plug from the wall outlet when changing needles, presser foot or needle plate, or when leaving the machine unattended. This eliminates the possibility of starting the machine by accidentally pressing the foot control.
- All covers must be closed when operating the machine.
- Do not pull the fabric while you are stitching as this may deflect the needle, causing it to break.
- Before cleaning your machine, disconnect the power supply plug from the wall outlet.
- Do not attempt to adjust the motor belt. Contact your nearest Service Center should any adjustment be required.
- Handle the foot control with care and avoid dropping it on the floor. Be sure not to place anything on top of it.
- Closely watch the area being sewn to avoid injuries from needles and knives.
- Use only the handle to lift and move the machine.

Kenmore Overlock

Record in space provided below the model number and serial number of this appliance. The model number and serial number are located on the nomenclature plate, as identified on Page 3 of this booklet.

Model No. 385. _____ Serial No. _____
Retain these numbers for future reference.

TABLE OF CONTENTS

SECTION 1. KNOW YOUR MACHINE

| | |
|-------------------------------|-----|
| Locate and Identify the Parts | 3~4 |
| Identify the Accessories | 4 |

SECTION 2. PREPARE YOUR MACHINE FOR SEWING

| | |
|---|-------|
| Plug in the Machine and Switch on the Power | 5 |
| Foot Control Use | 5 |
| How to Turn Hand Wheel | 6 |
| Opening and Closing the Side Cover | 6 |
| Opening and Closing the Loper Cover | 6 |
| The Position of Thread Guide Bar | 7 |
| Attaching the Spool Cap and Net | 7 |
| Raising or Lowering the Presser Foot | 8 |
| Threading the Machine | 9~17 |
| • Threading the Lower Loper | 10~11 |
| • Threading the Upper Loper | 12~13 |
| • Threading the Needle on the Right | 14~15 |
| • Threading the Needle on the Left | 16~17 |

SECTION 3. LEARN THE STITCHES

| | |
|-----------------------------------|-------|
| Starting Sewing | 18 |
| Finishing Sewing | 18 |
| Sewing Continuously | 18 |
| Securing Ends | 19~20 |
| Thread Tension (4 threads) | 21~23 |
| Threading the Machine (3 threads) | 24 |
| Thread Tension (3 threads) | 24~25 |
| Adjustment of Stitch Length | 26 |
| Adjustment of Foot Pressure | 26 |
| Removing the Presser Foot | 27 |

| | |
|--|-------|
| Attaching the Presser Foot | 27 |
| Changing Needle | 28 |
| To Disengage the Upper Knife | 29 |
| To Engage the Upper Knife | 29 |
| Types of Needle Plates | 30 |
| Changing the Needle Plate | 30 |
| Thread and Needle Chart | 31 |
| Rolled Hemming, Picot Edging and Narrow Hemming | 32~34 |
| Decorative Overedging | 35 |
| Pin Tucking | 36 |

SECTION 4. CARE FOR YOUR MACHINE

| | |
|---------------------------|----|
| Cleaning Upper Knife Area | 37 |
| Cleaning the Feed Dog | 37 |
| Replacing the Light Bulb | 38 |
| Oiling the Machine | 39 |
| Replacing the Upper Knife | 40 |

SECTION 5. PERFORMANCE PROBLEMS CHART

| | |
|-----------------|----|
| What to Do When | 41 |
|-----------------|----|

| | |
|------------|----|
| PARTS LIST | 42 |
|------------|----|

| | |
|-------|----|
| INDEX | 43 |
|-------|----|

| | |
|------------------------------|----|
| Specification of the Machine | 44 |
|------------------------------|----|

Locate and Identify the Parts

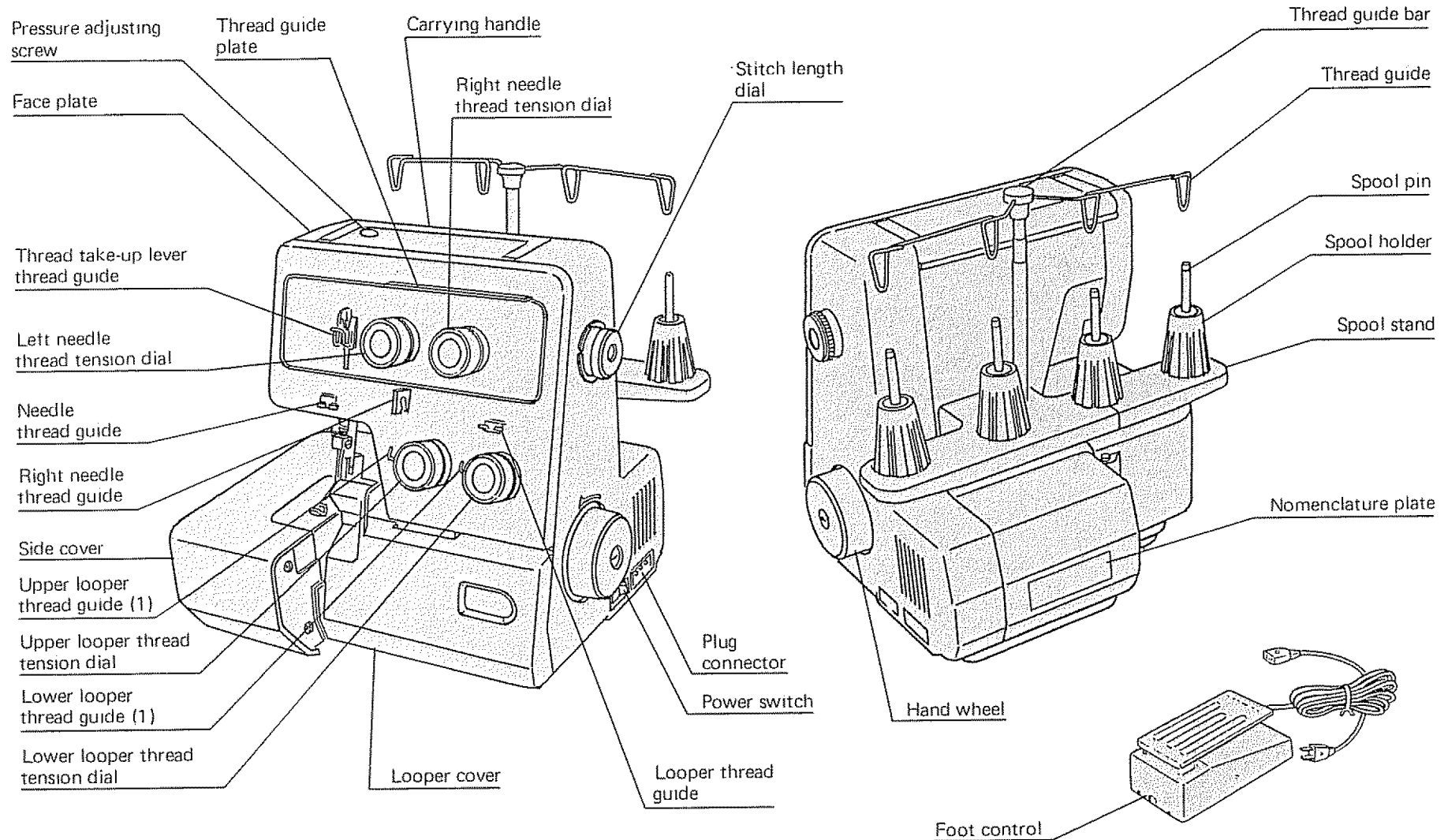

SECTION 1. KNOW YOUR MACHINE

Locate and Identify the Parts (Continued)

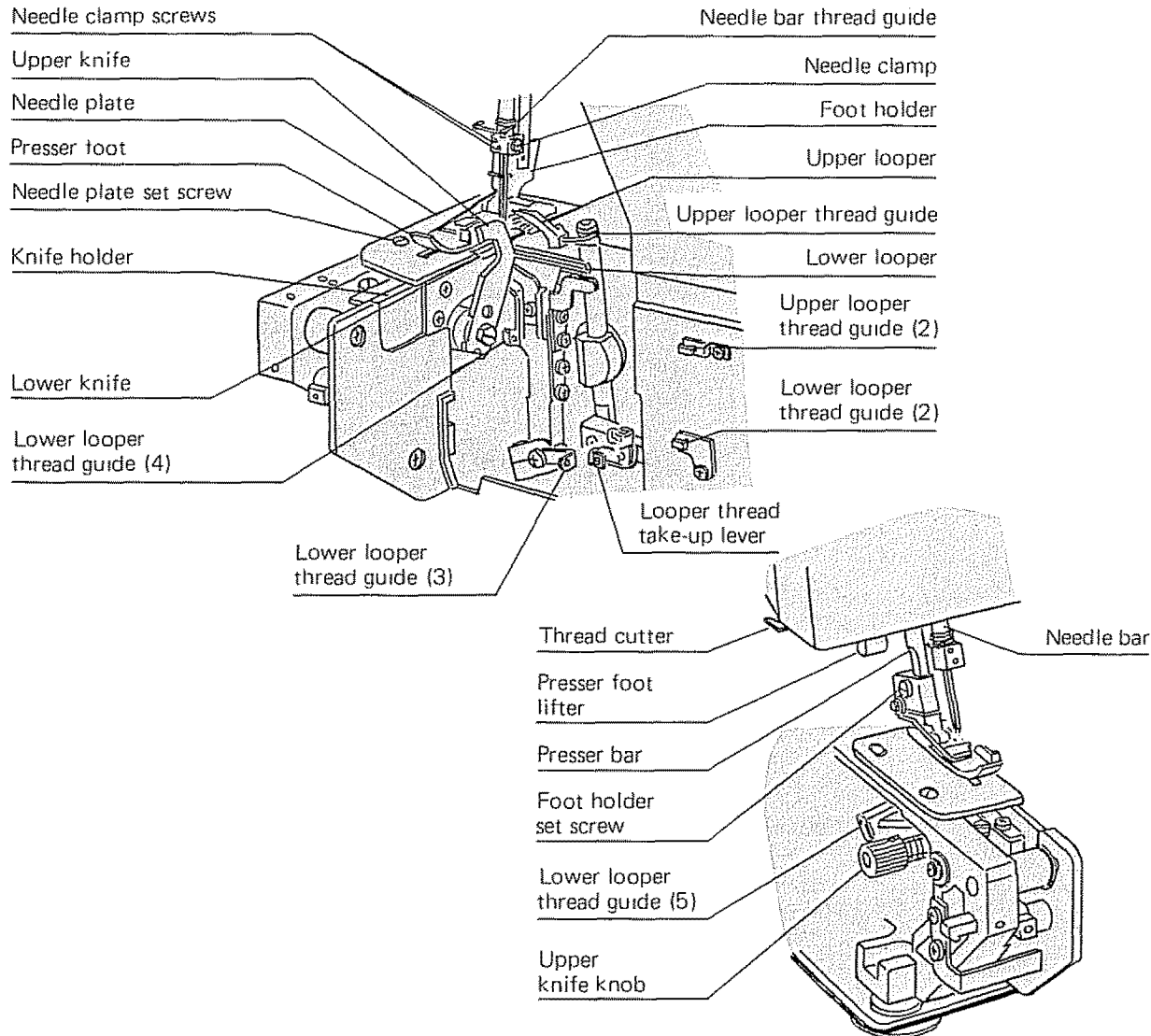

Identify the Accessories

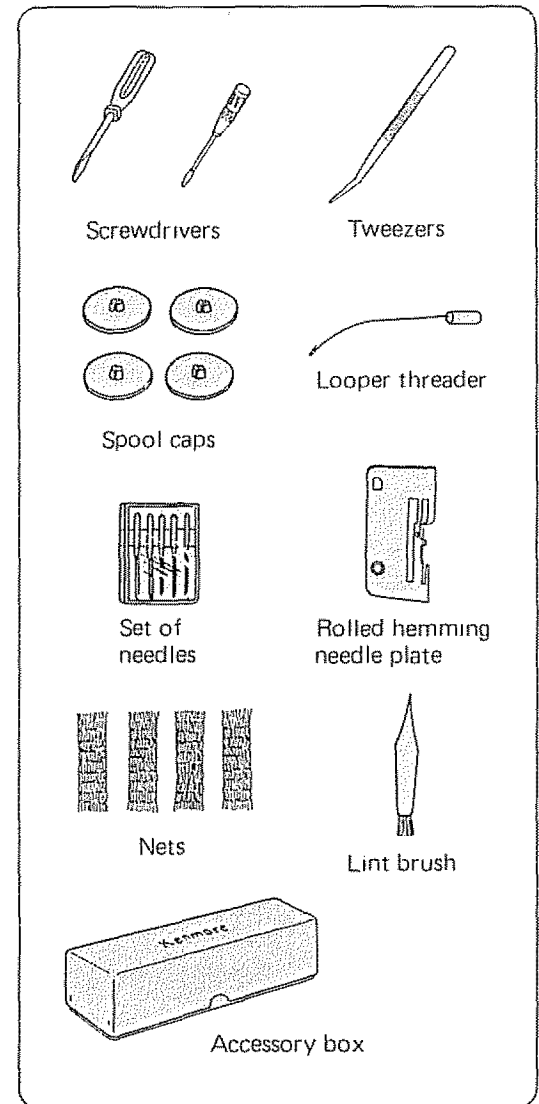

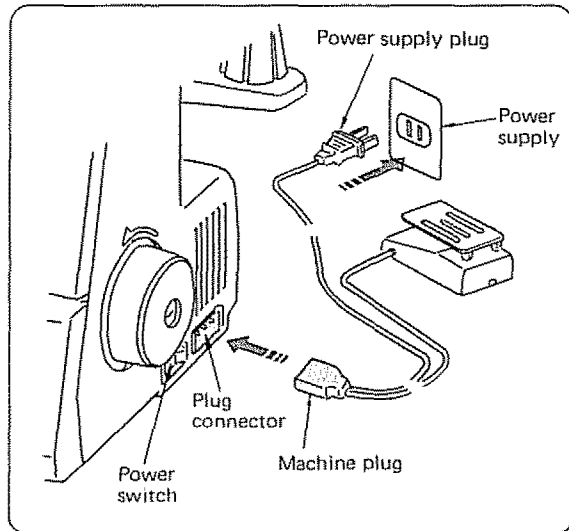
Plug in the Machine and Switch on the Power

NOTE: Before inserting the plug into your machine, be sure the power switch is OFF.

1. Check your outlet to be sure it is a 110 to 120 Volt AC outlet.
2. Insert the machine plug into the three-prong plug connector, as shown. It will only fit one way.
3. Insert the power supply plug into the wall outlet.

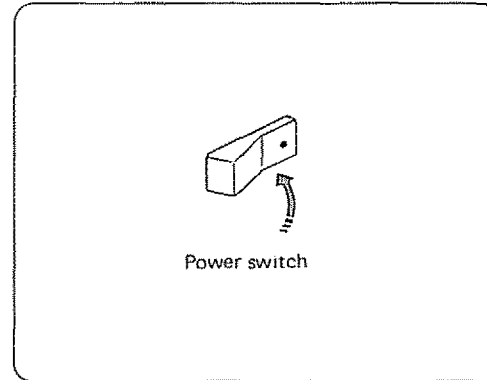

4. Push the light and power switch to turn on the power and sewing light.

SAFETY FEATURE:

Your machine will not operate unless the light/power switch is turned on. If you are interrupted or stop sewing, turn off the light/power switch to prevent injury to children.

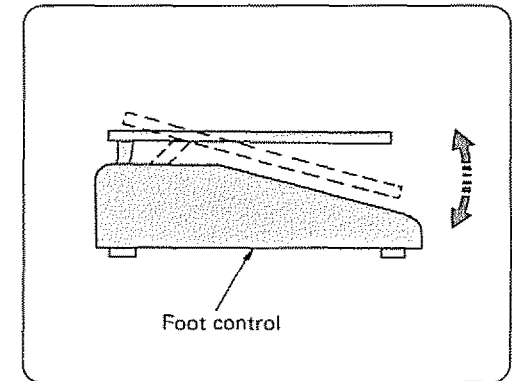
Foot Control Use

The foot control regulates the speed at which you sew.

To increase speed, gently press down with the ball of your foot.

To decrease speed, release your foot pressure slightly.

NOTE: The foot control is sensitive and will increase or decrease your sewing speed immediately. Practice on a scrap of fabric to regulate your sewing speed to your taste and needs.

SECTION 2. PREPARE YOUR MACHINE FOR SEWING

How to Turn Hand Wheel

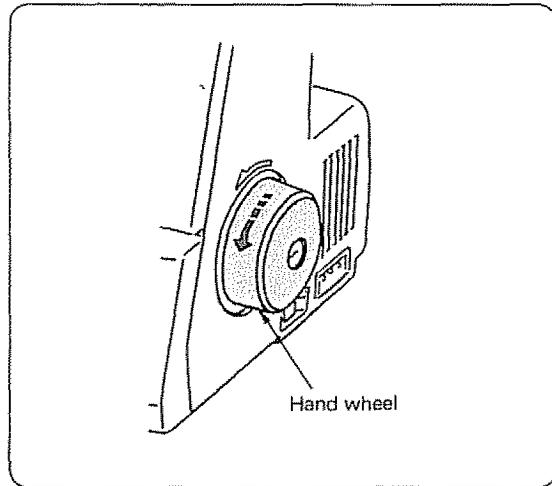

Always turn hand wheel toward you.

Opening and Closing the Side Cover

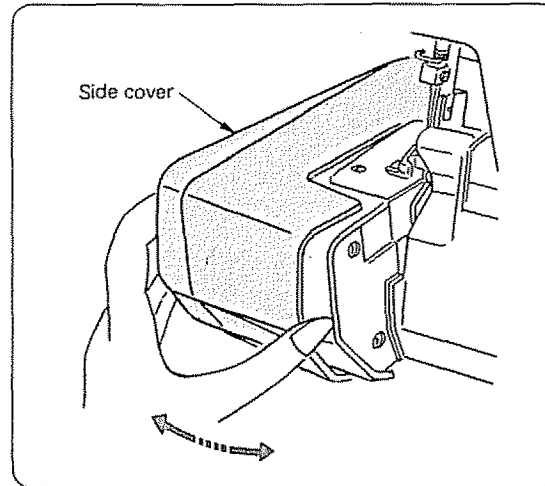

To open:

Push the side cover to the left.

To close:

Push the side cover to the right and slightly toward the machine body.

Opening and Closing the Loper Cover

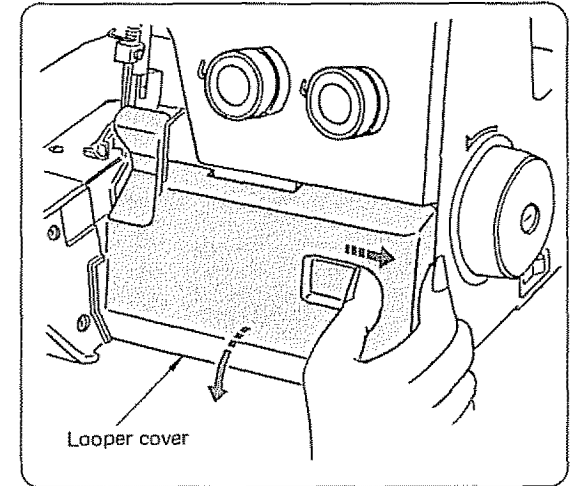

To open:

While pushing with the thumb to the right as far as it will go, pull looper cover toward you.

To close:

Lift looper cover and push against the machine. The looper cover snaps into the position automatically.

For Your Safety:

Always close both side and looper covers when the machine is in use.

The Position of Thread Guide Bar

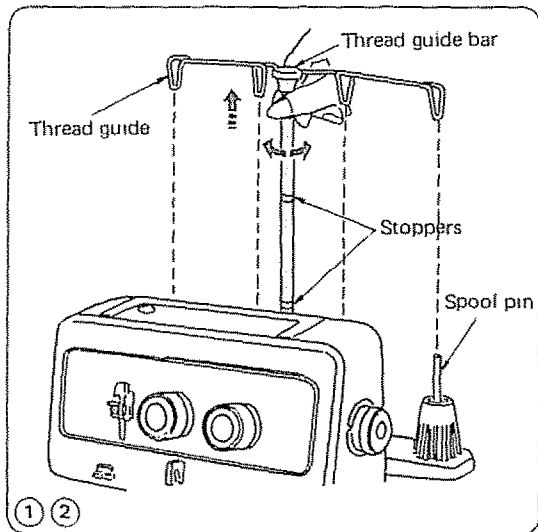

- ① Pull the thread guide bar up as far as it will go.
- ② Turn the thread guide bar so that the thread guides are right above the spool pins.

Attaching the Spool Cap and Net

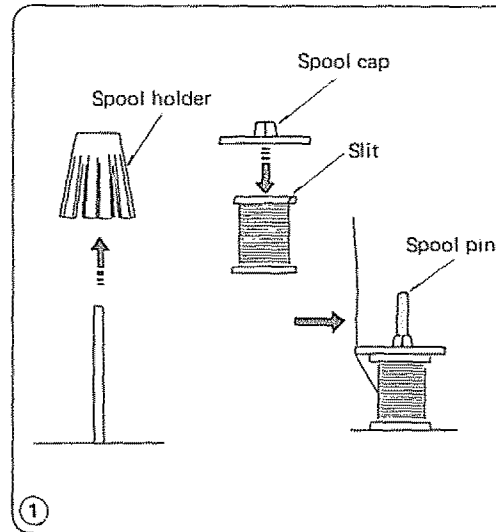

- ① When you use a small thread spool, remove the spool holder from the spool pin. Then place the spool with its slit side up, and put spool cap on top.
- ② If the thread slips down from the spool during threading and/or sewing, put a net on the spool as illustrated for preventing jamming. The nets are supplied with the machine.

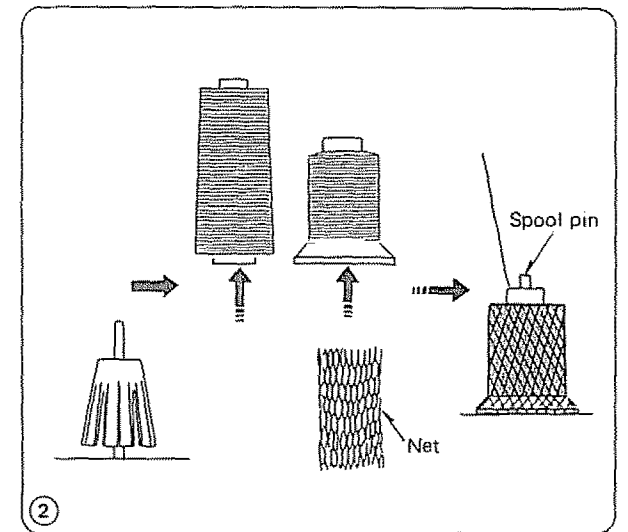

SECTION 2. PREPARE YOUR MACHINE FOR SEWING

Raising or Lowering the Presser Foot

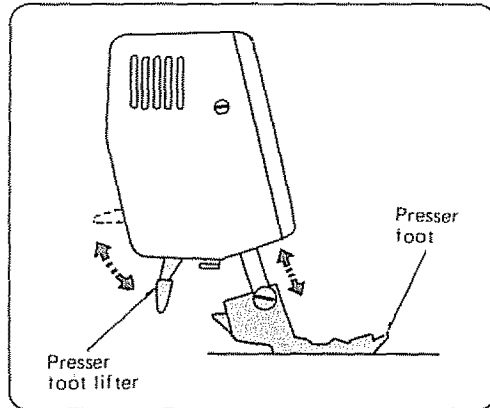

By raising or lowering the presser foot lifter, the presser foot goes up and down.

- * While in operation, keep the presser foot lowered except for testing stitches, threading the machine or sewing heavy weight fabrics.

NOTE: Thread tension will not be released if the presser foot is raised.

Threading the Machine

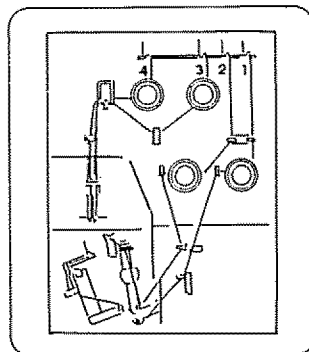
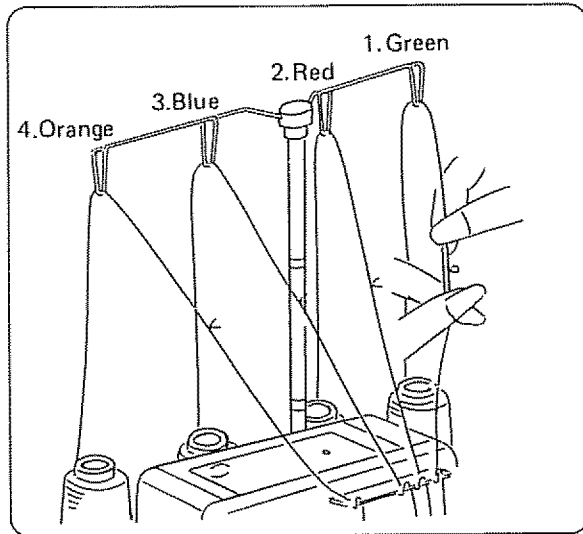

Threading Chart

(Located behind looper cover)

For your convenience, your Kenmore overlock has been pre-threaded. To prepare to sew with your choice of threads, follow these simple instructions:

- Connect the power supply plug to the wall outlet and turn on the power switch (Page 5 in owner's manual).
- Raise thread guide bar to highest position; open side cover and looper cover (Page 6 in owner's manual).
- Untie knot holding threads together.
- Place a thread cone on far right spool holder. Securely tie end of thread from cone to thread farthest on right of thread guide bar (GREEN).
- Pull thread, guiding knot through tension disc, thread guides and lower looper.
- Place a second thread cone on second spool holder from right. Securely tie end of thread from cone to thread second from right on thread guide bar (RED).
- Pull thread, guiding knot through tension disc, thread guides and upper looper.
- Place a third thread cone on the second from left spool holder. Securely tie end of thread from cone to thread located second from left on thread guide bar (BLUE).
- Pull thread, guiding knot through tension disc and thread guides. Before reaching needle, remove presser foot (Page 27 in owner's manual). Clip thread on both sides of knot. Pull old thread out of right needle and thread new thread through needle. Use looper threader or tweezers to make threading easier. Knife may be lowered to give you more room to work (Page 29 in owner's manual).
- Place a fourth cone of thread on spool holder at far left. Securely tie end of thread from cone to thread on far left of thread guide bar (ORANGE).
- Pull thread, guiding knot through tension disc and thread guides. Before reaching needle, clip thread on both sides of knot. Pull old thread out of left needle and thread new thread through needle.
- Pull both sides of thread firmly between each tension disc (Pages 11, 13, 15, 17 in owner's manual).
- Refer to threading chart behind looper cover to check threading paths.
- Gently pull all four thread ends towards back of machine.
- Replace presser foot (Page 27 in owner's manual). Return knife to up position (Page 29 in owner's manual). Close side cover and looper cover (Page 6 in owner's manual).
- Turn hand wheel toward you to chain off three or four stitches.
- Place fabric under the toe of the presser foot; it is not necessary to raise the foot. **YOU ARE NOW READY TO BEGIN SERGING!**

SECTION 2. PREPARE YOUR MACHINE FOR SEWING

• Threading the Lower Looper

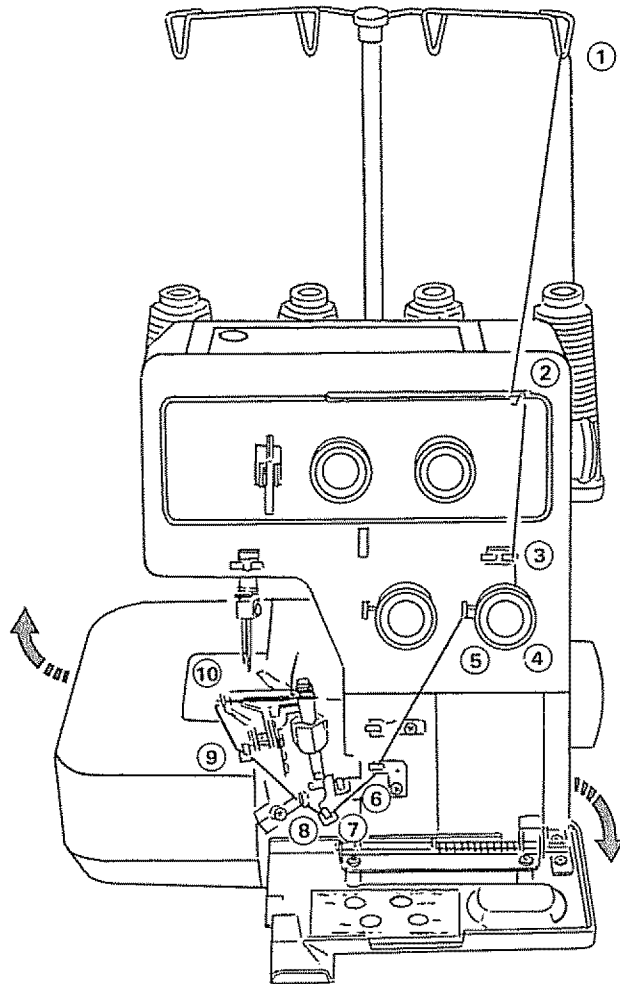

Open the looper and side covers.
Loosen screw and remove presser foot assembly.
Place the spool of thread on the right side spool pin.

* Points to thread for lower looper are marked in green.

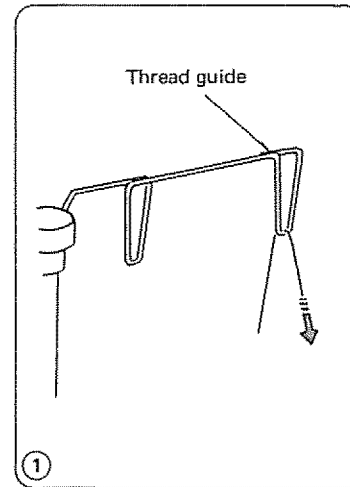

① Draw the thread through the right side thread guide from back to front.

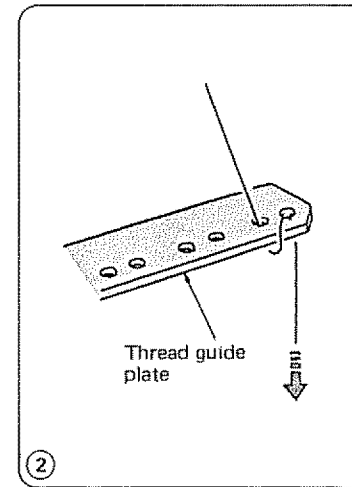

② Pass the thread through holes on the right side of thread guide plate as illustrated.

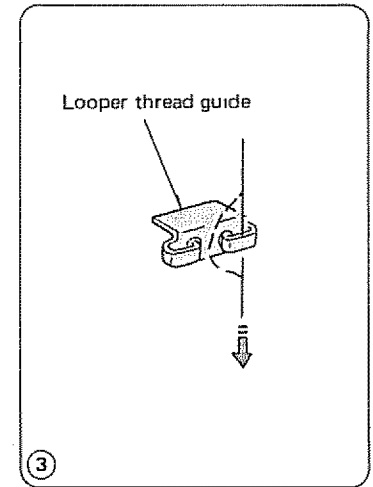

③ Pass the thread through the right side of thread guide sliding the thread from left to right.

How to Thread the Lower Looper

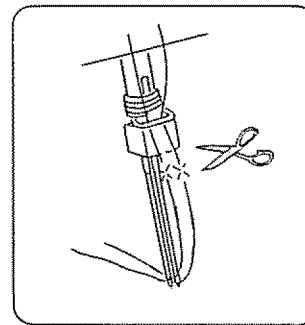

Cut the both needle threads as shown in the figure and remove them from the needles.

Thread the lower looper and then re-thread the needles.

SECTION 2. PREPARE YOUR MACHINE FOR SEWING

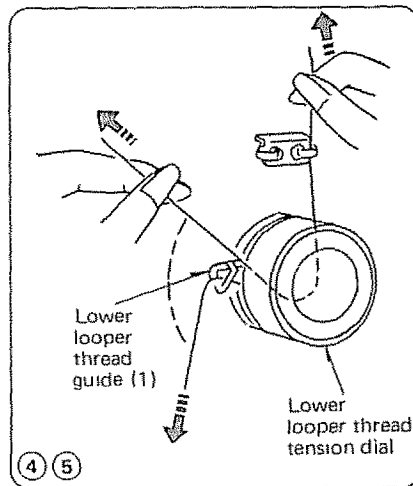

- ④ Insert the thread between tension discs from the right. Then pull both sides of the thread firmly between tension discs.
- ⑤ Pass the thread through lower looper thread guide (1).

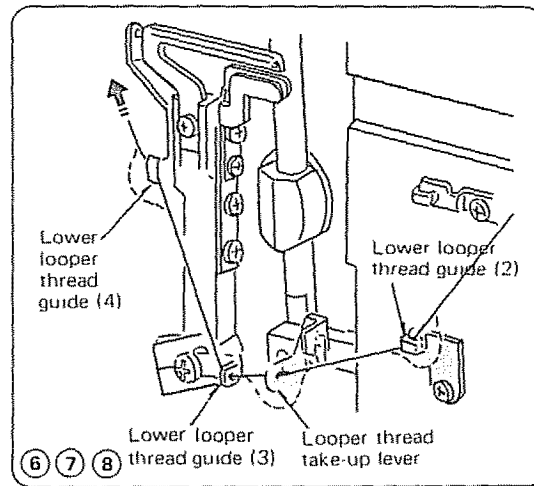

- ⑥ Pass the thread through the thread guide (2).
- ⑦ Pass the thread through the looper thread take-up lever (lower).
- ⑧ Pass the thread through the thread guides (3) and (4).

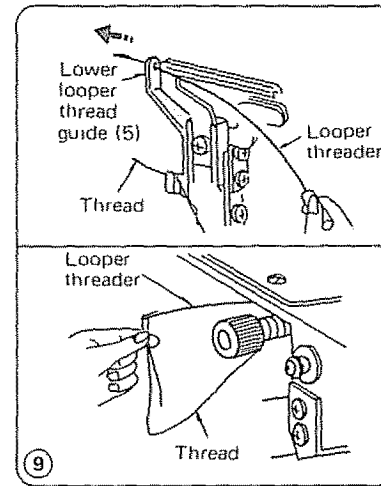

- ⑨ Turn the hand wheel toward you until the lower looper comes to the left, pass the threader through hole on lower looper thread guide (5). Hook the end of thread on the threader.

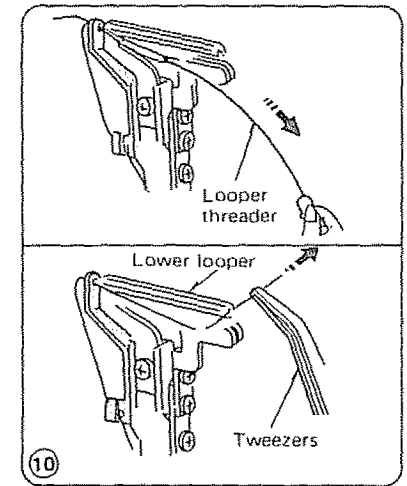

- ⑩ Pull the threader to pass the thread through the hole of lower looper thread guide (5). Remove the thread from the threader, and draw the thread through the hole on lower looper 10 cm (4") or more with a pair of tweezers.

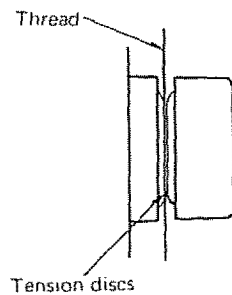

* Make sure that the thread is between the tension discs.

How to Thread Woolly Nylon/Polyester Thread

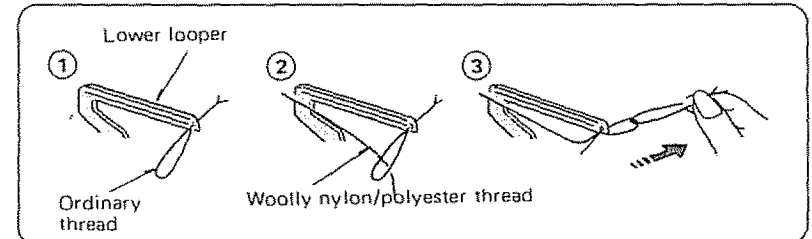

- * To pass the woolly nylon/polyester thread shown above is one of the easiest ways to do so.
- * Use the same method for the upper looper.

SECTION 2 PREPARE YOUR MACHINE FOR SEWING

• Threading the Upper Looper

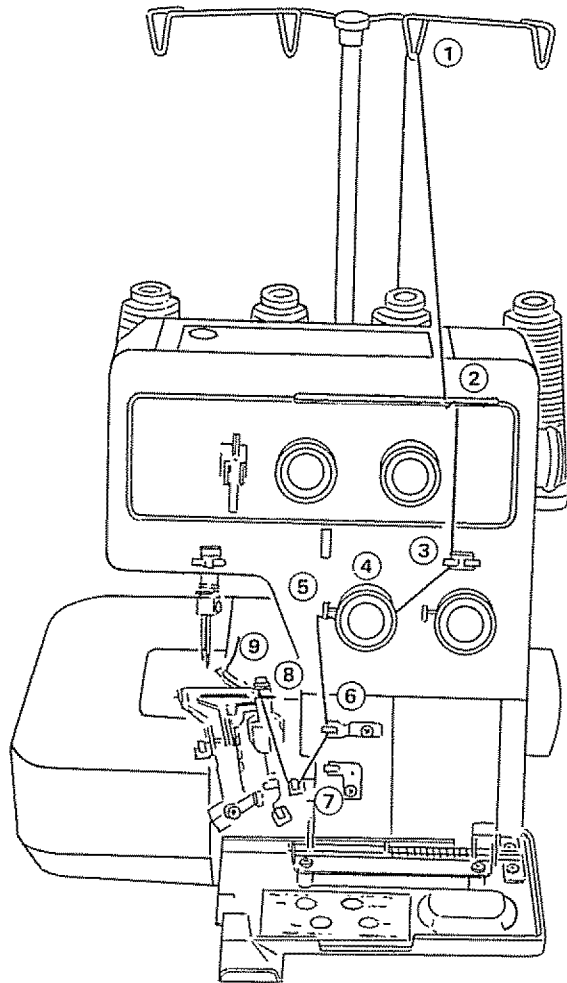

Place the spool of thread on the spool pin second from the right.

* Points to thread for upper looper are marked in red.

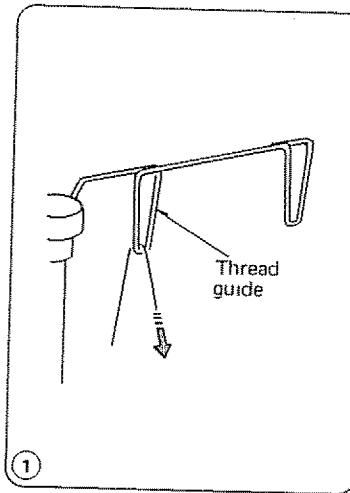

① Draw the thread through the thread guide second from the right from back to front.

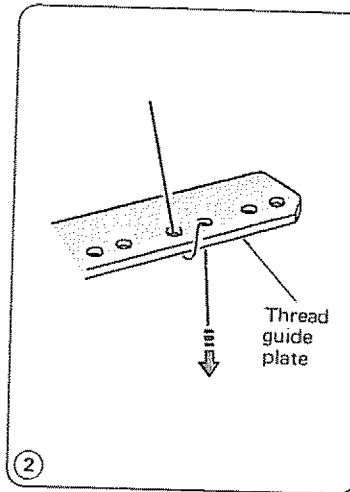

② Pass the thread through the holes in the second row from the right of thread guide plate as illustrated.

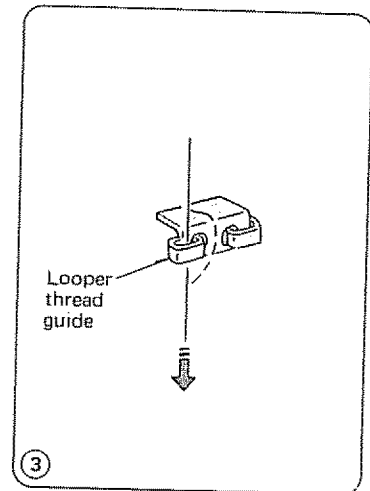

③ Pass the thread through the left side of thread guide sliding the thread from right to left.

How to Thread the Upper Looper

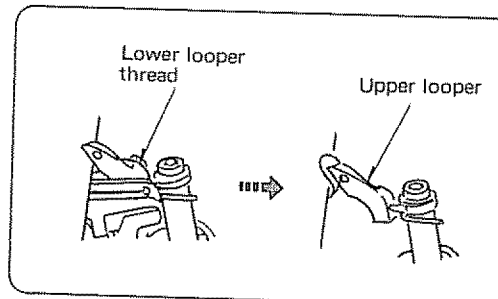

Turn the hand wheel toward you until the upper looper comes to the middle point of its travel, and unhook the thread of the lower looper from the upper looper.

Thread the upper looper.

SECTION 2. PREPARE YOUR MACHINE FOR SEWING

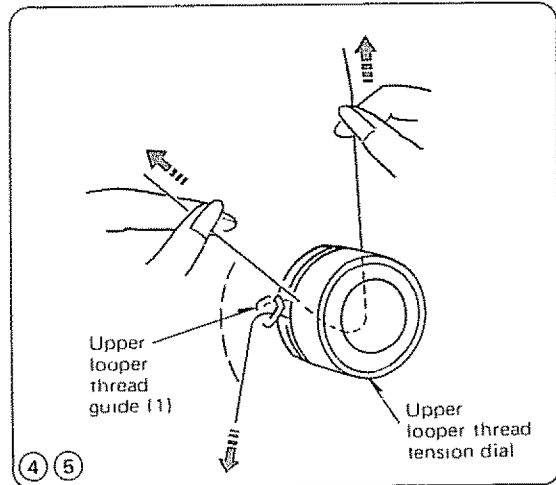

- ④ Insert the thread between tension discs from the right. Then pull both sides of thread.
- ⑤ Pass the thread through upper looper thread guide (1).

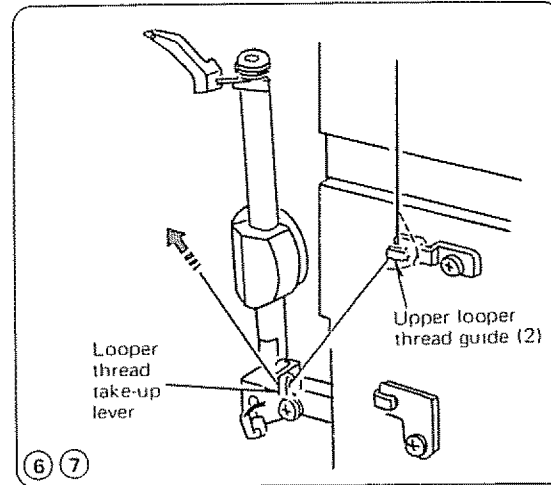

- ⑥ Pass the thread through upper looper thread guide (2).
- ⑦ Pass the thread through the looper thread take-up lever (upper).

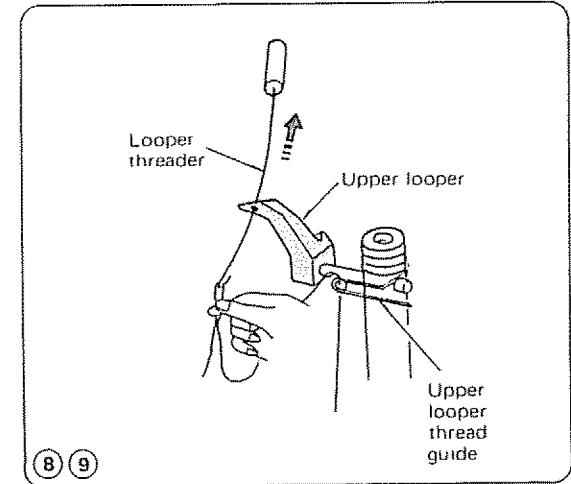

- ⑧ Pass the thread through upper looper thread guide.
- ⑨ Pass the threader through the hole on the upper looper. Then hook the end of thread on the threader. Pull out the threader to pass the thread through the hole. Remove the thread from threader, and draw the free end of thread 10 cm (4") or more.

SECTION 2. PREPARE YOUR MACHINE FOR SEWING

• Threading the Needle on the Right

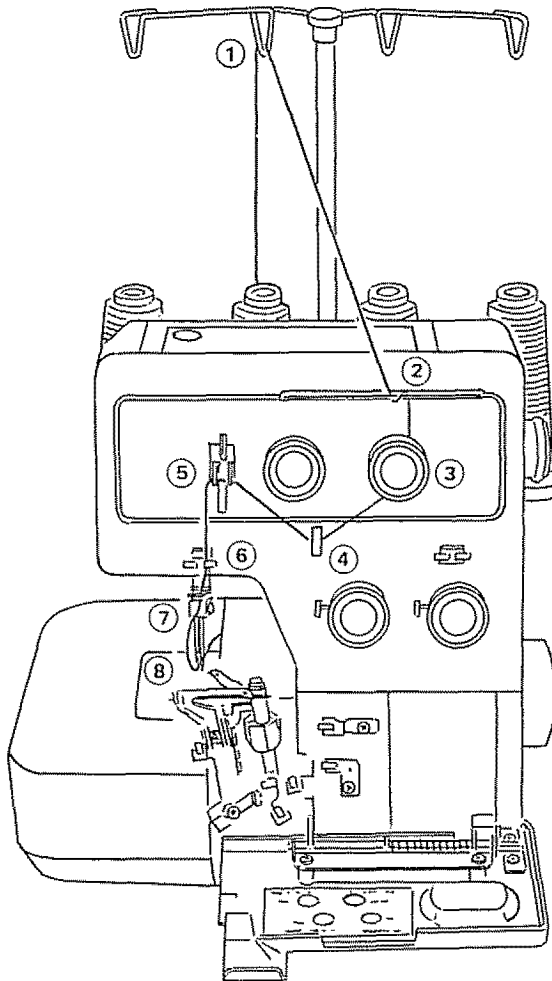

Place the spool of thread on the spool pin second from the left.

* Points to thread for needle on the right are marked in blue.

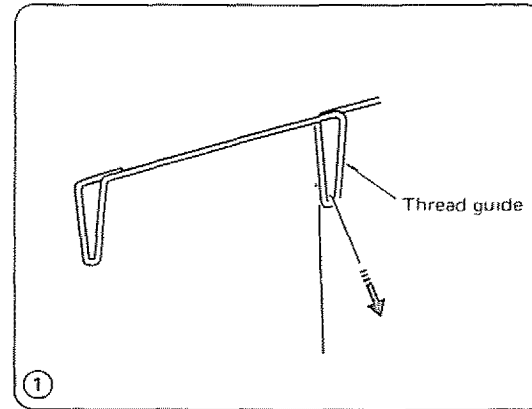

① Draw the thread through the thread guide second from the left from back to front.

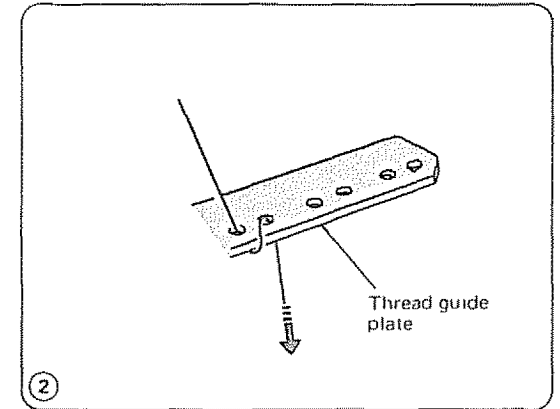

② Pass the thread through the holes in the second row from the left of thread guide plate as illustrated.

SECTION 2. PREPARE YOUR MACHINE FOR SEWING

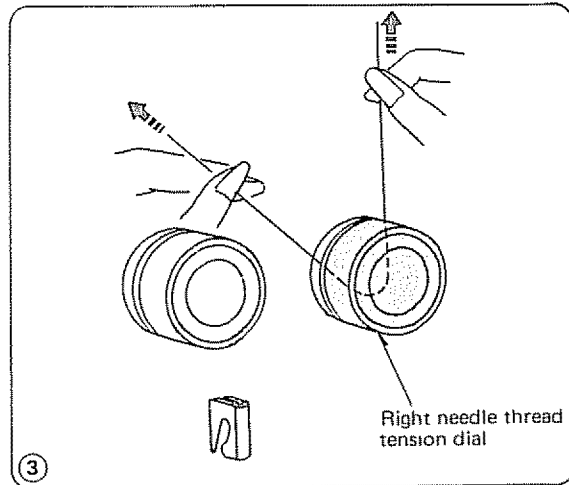

- ③ Insert the thread between tension discs from the right. Then pull both sides of thread.

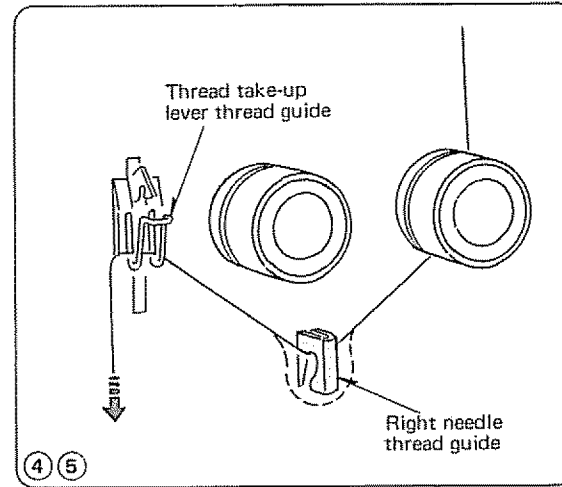

- ④ ⑤ Turn the hand wheel toward you to bring needle bar to its highest position, then pass the thread through right needle thread guide and thread take-up lever thread guide.

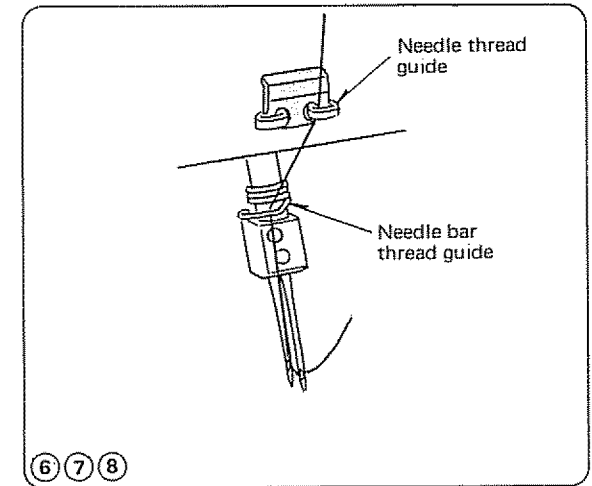

- ⑥ Pass the thread through the thread guide sliding the thread from left to right.
- ⑦ Pass through needle bar thread guide from left to right.
- ⑧ Thread the right needle from the front to the back and pull the thread about 10 cm (4") from the eye of the needle to the back under the foot.

NOTE: Needle may be easier to thread if you remove presser foot (See page 27) and lower knife (See page 29).

SECTION 2. PREPARE YOUR MACHINE FOR SEWING

• Threading the Needle on the Left

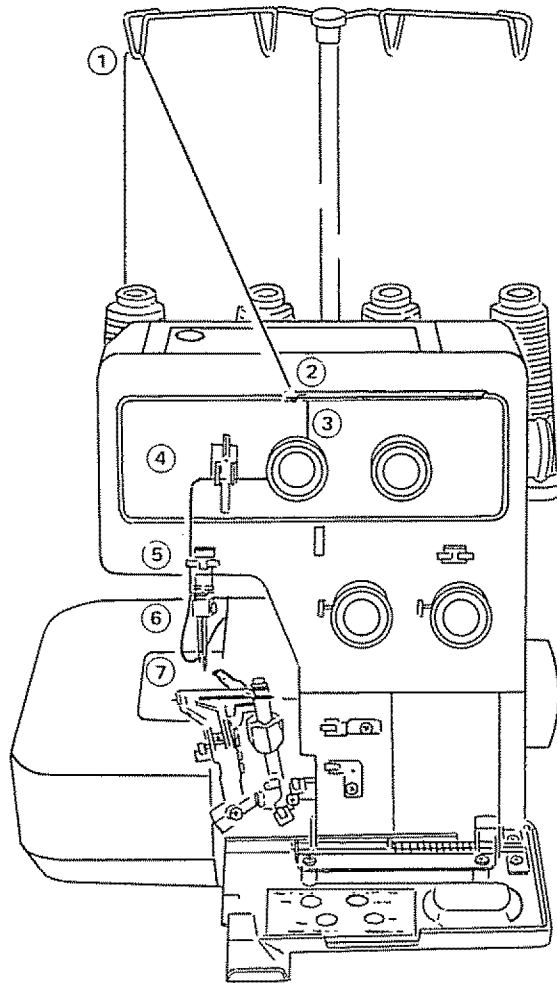

Place the spool of thread on the left side spool pin.

* Points to thread for needle on the left are marked in orange.

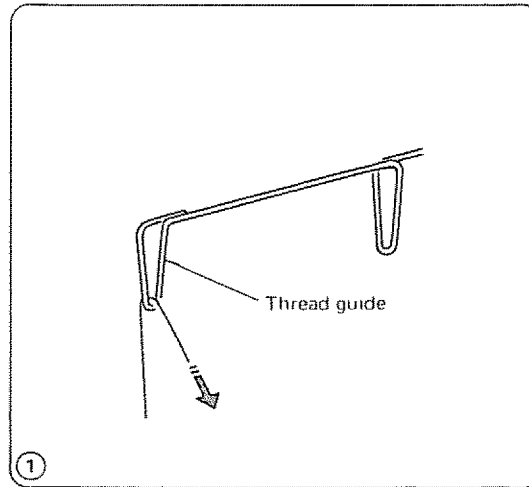

① Draw the thread through the thread guide on the left from back to front.

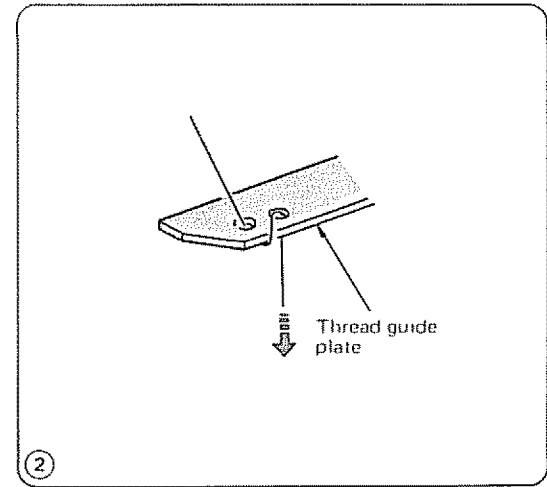

② Pass the thread through the holes on the left of thread guide plate as illustrated.

SECTION 2. PREPARE YOUR MACHINE FOR SEWING

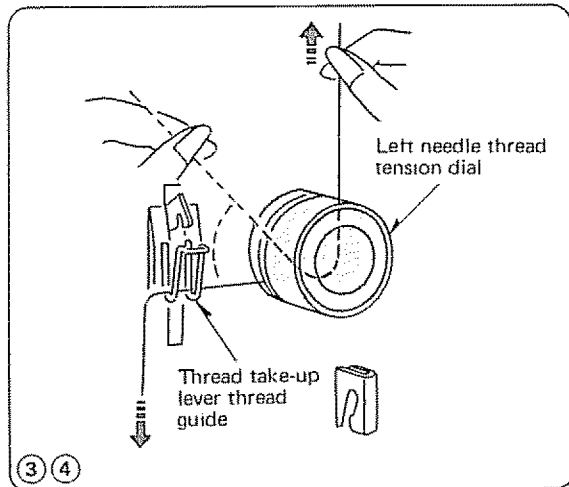

- ③ Insert the thread between tension discs from the right. Then pull both sides of thread.
- ④ Turn the hand wheel toward you to bring needle bar to its highest position, then pass the thread through thread take-up lever thread guide.

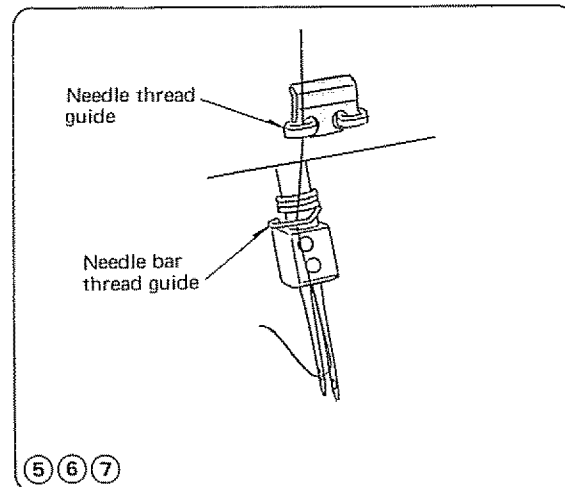

- ⑤ Pass the thread through the thread guide sliding the thread from right to left.
- ⑥ Pass through needle bar thread guide from left to right.
- ⑦ Thread the left needle from the front to the back and pull the thread about 10 cm (4") from the eye of the needle to the back under the foot.

NOTE: Needle may be easier to thread if you remove presser foot (See page 27) and lower knife (See page 29).

- Gently pull all four thread ends towards back of machine.
- Replace presser foot (See page 27).
- Return knife to up position (See page 29).
- Close side and looper covers.
- Turn hand wheel toward you to chain off three or four stitches.
- Place fabric under the toe of the presser foot; it is not necessary to raise the foot.

SECTION 3. LEARN THE STITCHES

Starting Sewing

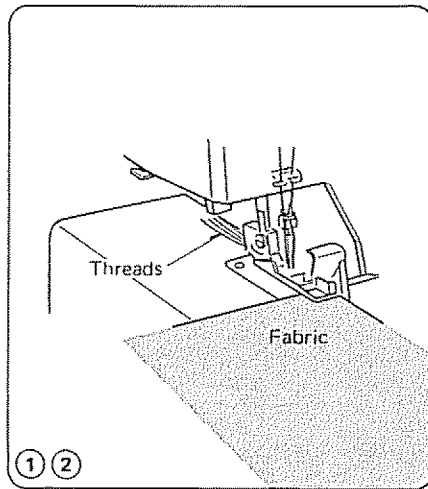

- ① Insert the fabric under the toe of the foot.
(It is not necessary to raise the foot.)
- ② Turn the hand wheel gently toward you a couple of turns and check the thread chain. Then start sewing slowly. The fabric will be automatically fed. Guide the fabric in the direction desired.

Finishing Sewing

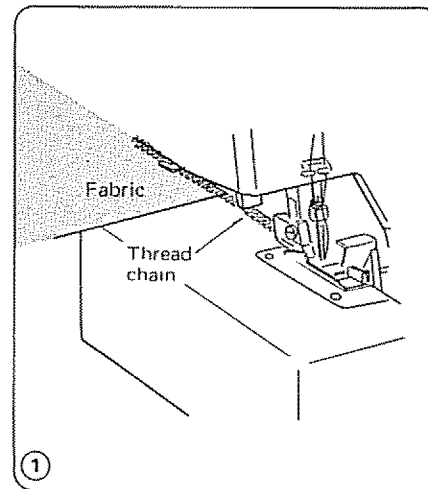

- ① When stitching is completed, continue to run the machine slowly to produce a thread chain for about 12 cm (5") while pulling the thread chain slightly to the back.

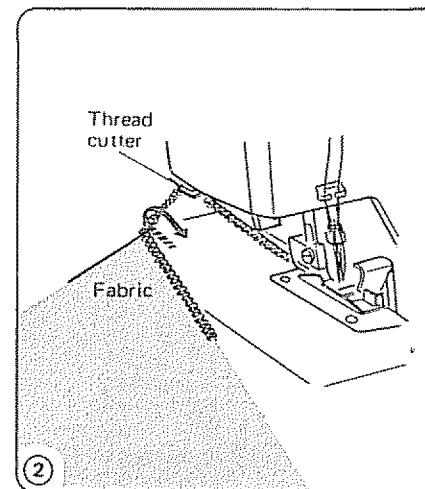

- ② Cut the threads with the thread cutter as illustrated, leaving about 5 cm (2") thread chain from the end of fabric.

Sewing Continuously

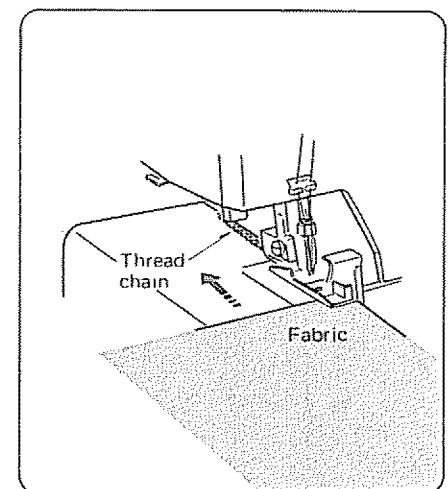

Insert next fabric under the toe of foot, then start sewing. It is not necessary to raise the presser foot for ordinary fabric.

- * For heavy weight fabric, raise the presser foot and insert the fabric in front of the knife. Then lower the foot and sew.

Securing Ends

To avoid unravelling, it is necessary to leave a thread chain about 5 cm (2") long at the beginning and end of seam. To secure the beginning and end of a seam choose one of the following methods.

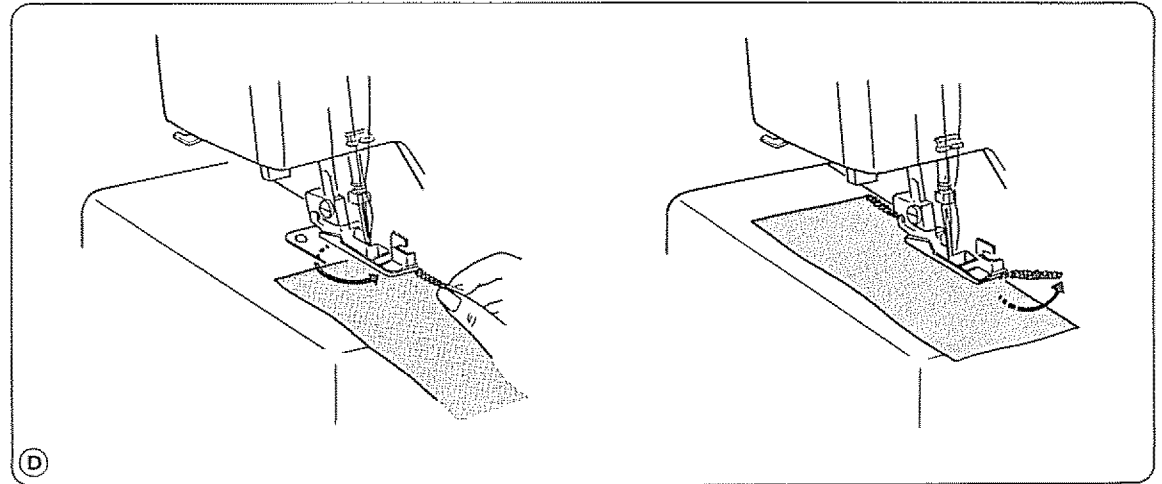
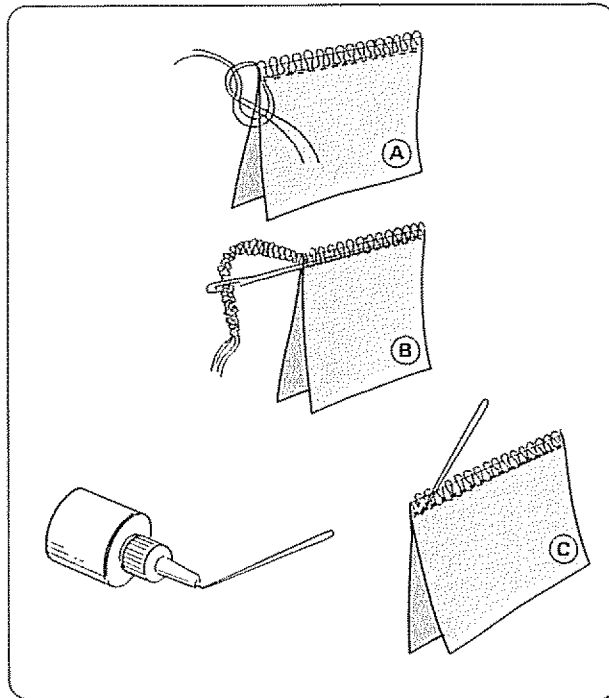

At the Beginning

- A. Separate the end of threads and knot.
- B. Thread the chain through a large eyed needle, and weave that chain through the overlock stitches on the fabric.
- C. Cut the chain at the edge of fabric. Then apply a small amount of seam sealant (Fray Check™ or Fray-No-More™) on the end of the threads.
- D. Backstitching
 1. Before putting your fabric in the machine, sew a thread chain about 5 cm (2") long behind the needle.
 2. Put your fabric in the machine. Then serge a few stitches and stop.
 3. Raise the presser foot and bring the thread chain to the left around and under the presser foot.
 4. Place the thread chain between the presser foot and upper knife, holding it in position as you lower the presser foot to sew.
 5. After sewing about 2.5 cm (1"), move the chain to the right and under the upper knife, cutting the chain as you sew.

SECTION 3. LEARN THE STITCHES

Securing Ends (continued)

At the End

You can use the same methods as at the beginning to secure the end of seam except "Backstitching", or the methods shown below.

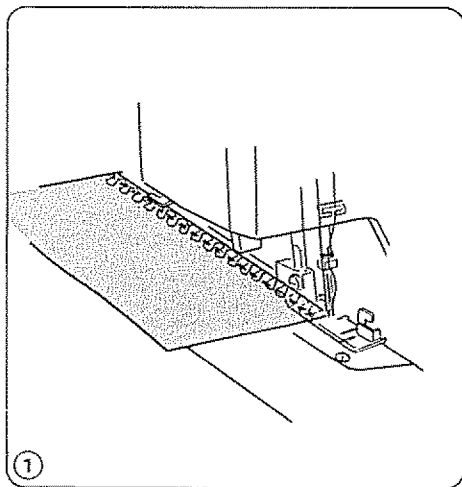

① Serge one stitch off the end of seam.

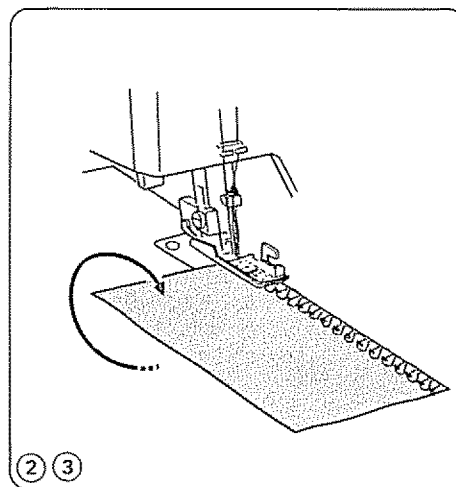

② Raise the needle and presser foot, and gently pull the threads off the prong.

③ Turn the fabric over so that the under side is up.

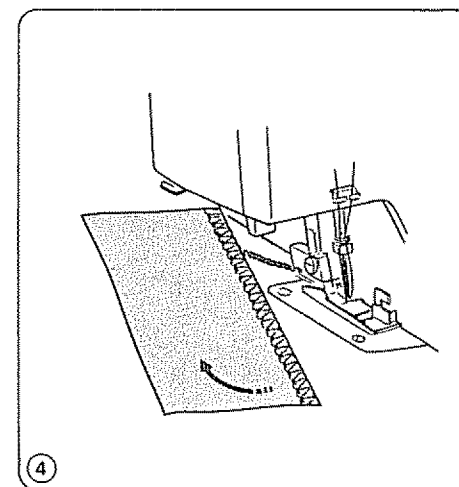

④ Serge about 2.5 cm (1") over stitching and angle off the fabric.

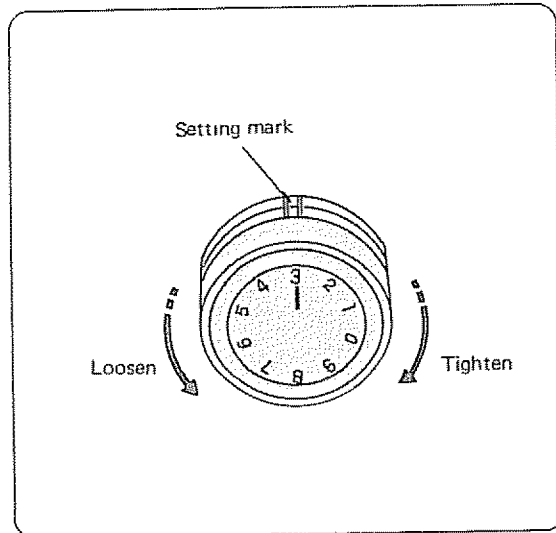
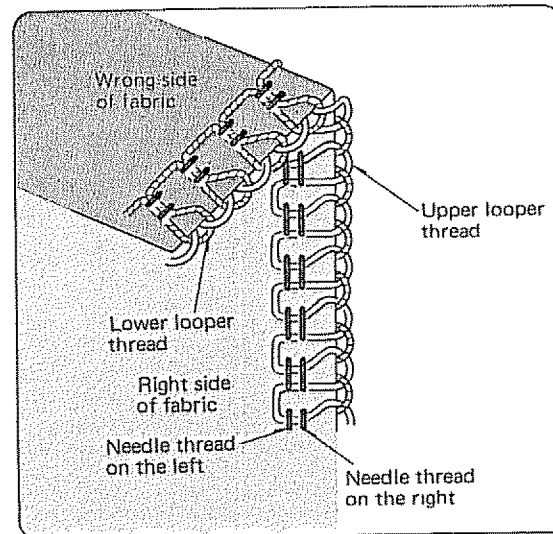
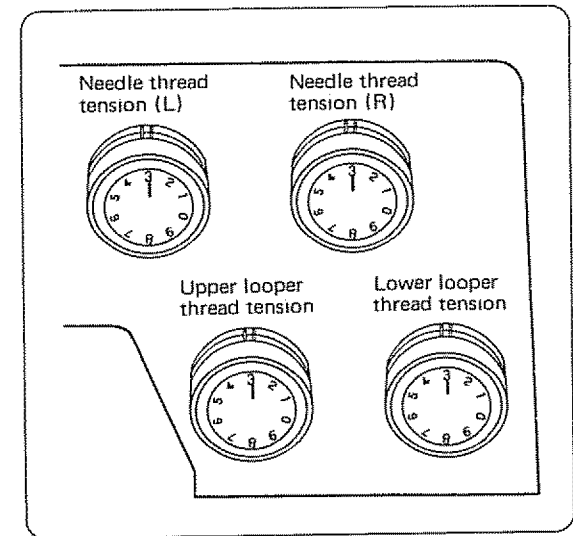
Thread Tension (4 threads)**Thread Tension Dial****Correct Tension****Thread Tension**

The line below the setting of 3 on each of the dials indicates normal tension for 4 threads or 3 threads serging, however, an alternate adjustment of the thread tension may be required depending on the type of fabric and thread being used.

Refer to pages 22 and 23 for the adjustment.

SECTION 3. LEARN THE STITCHES

Thread Tension (4 threads) (continued)

Thread Tension Adjustment

* Set all four thread tension dials at "3". Then sew, and check the thread tensions.

Wrong Tension

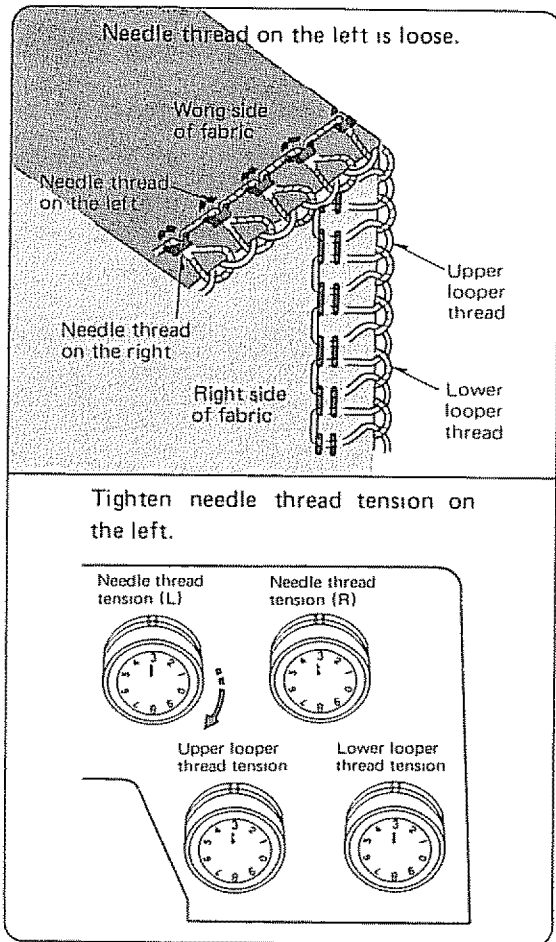

Wrong Tension

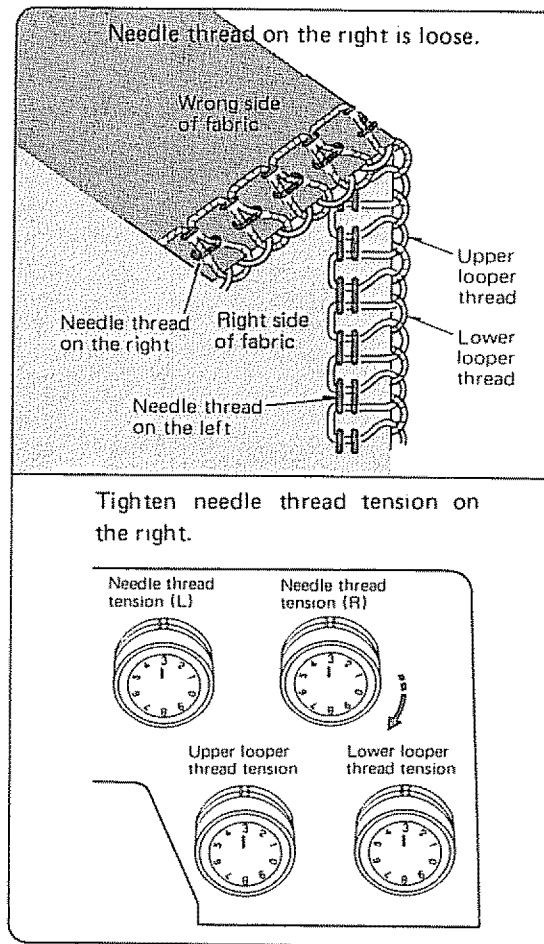

Correct Tension

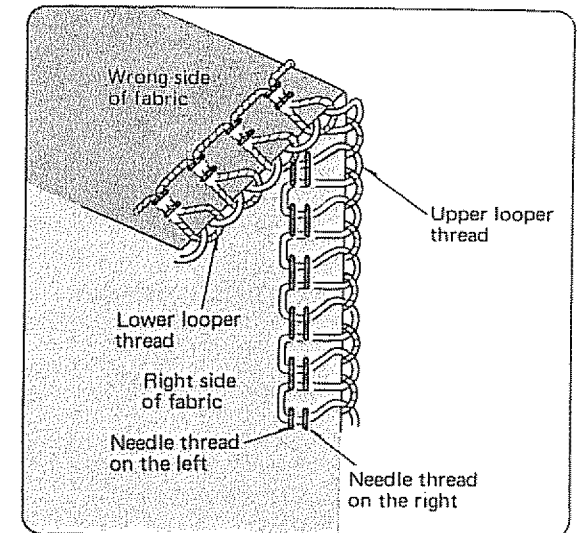

* It is easier to adjust by using 4 different colors of thread.

Wrong Tension

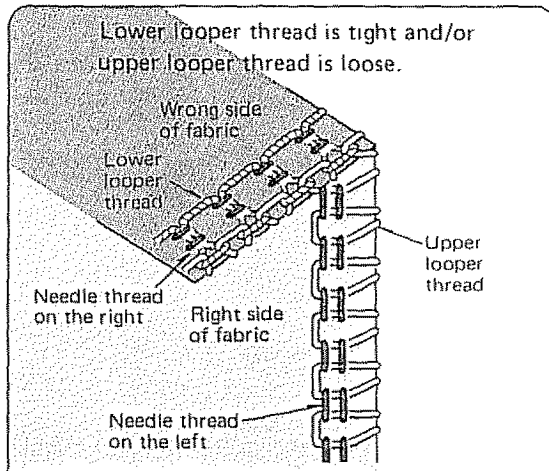

Loosen lower looper thread tension and/or tighten upper looper thread tension.

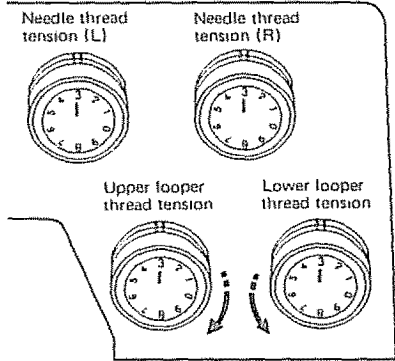

Wrong Tension

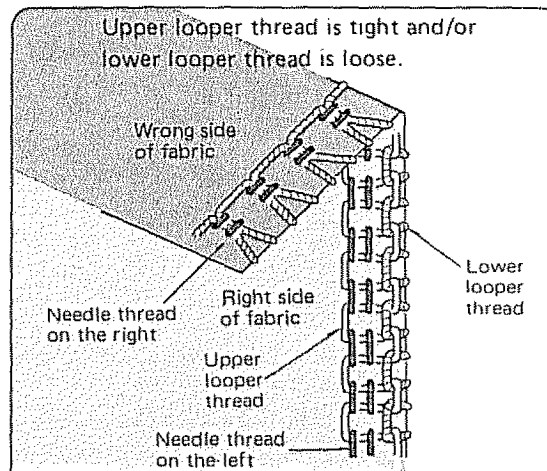

Loosen upper looper thread tension and/or tighten lower looper thread tension.

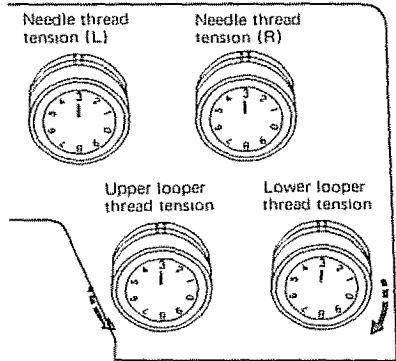

SECTION 3. LEARN THE STITCHES

Threading the Machine (3 threads)

Using the Needle on the Right Only
(for narrow three-thread serging)

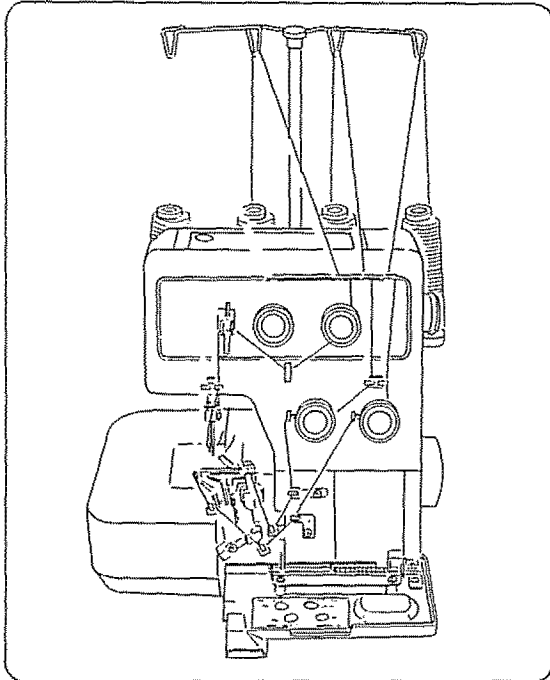

Disconnect the machine from the power supply. Remove the needle and the thread on the left. Then tighten the needle clamp screw on the left slightly to avoid losing the screw.

To change to the other needle in three-thread serging

Loosen both needle clamp screws and remove the needle. Insert the needle and tighten the needle clamp screw for the needle to be used while pushing the needle up as far as it will go. Then tighten the needle clamp screw on the other side slightly to prevent the screw from dropping.

Using the Needle on the Left Only
(for wide three-thread serging)

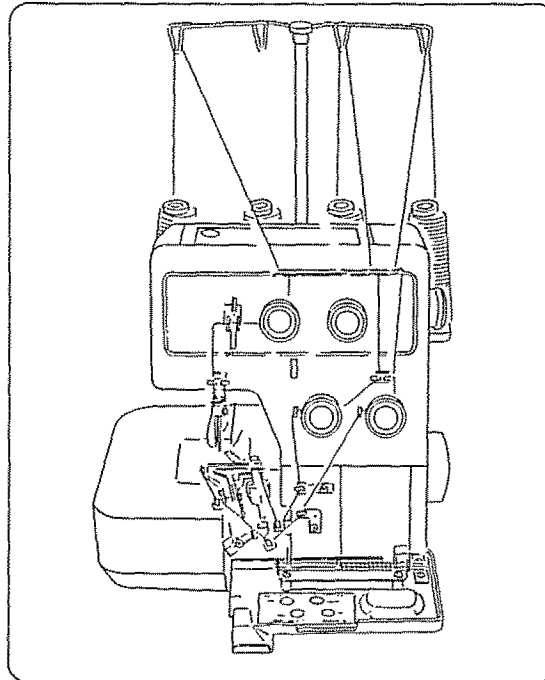

Remove the needle and the thread on the right. Then tighten the needle clamp screw on the right slightly to avoid losing the screw.

Thread Tension (3 threads)

Correct Tension

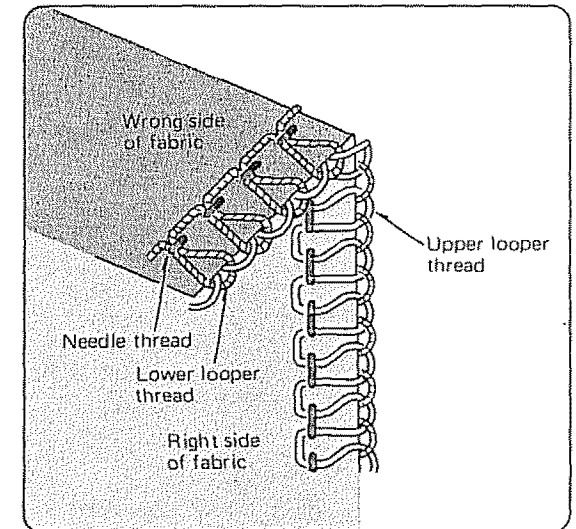

Adjusting the thread tension may be required depending on the type of fabric and thread being used.

Refer to page 25 for the adjustment.

Thread Tension Adjustment

* Set all three thread tension dials at "3" Then sew, and check the thread tensions.

Wrong Tension

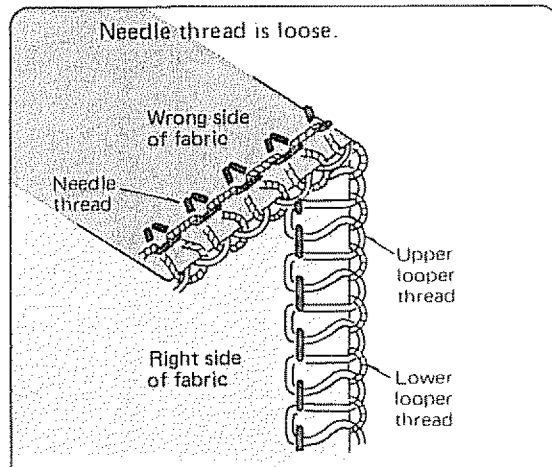

Tighten needle thread tension.

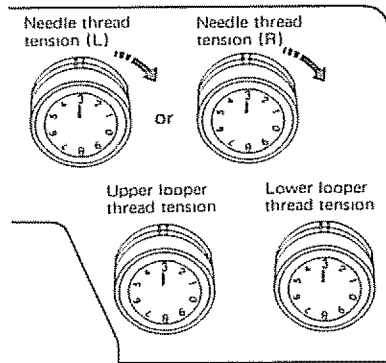

Wrong Tension

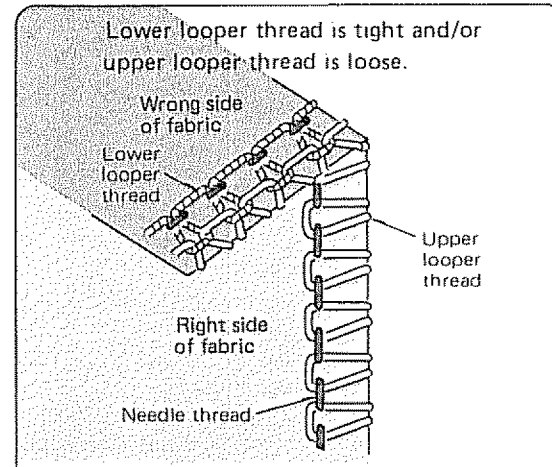

Loosen lower looper thread tension and/or tighten upper looper thread tension.

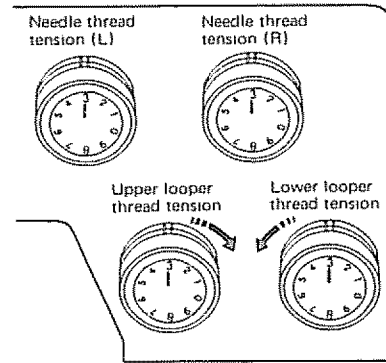

Wrong Tension

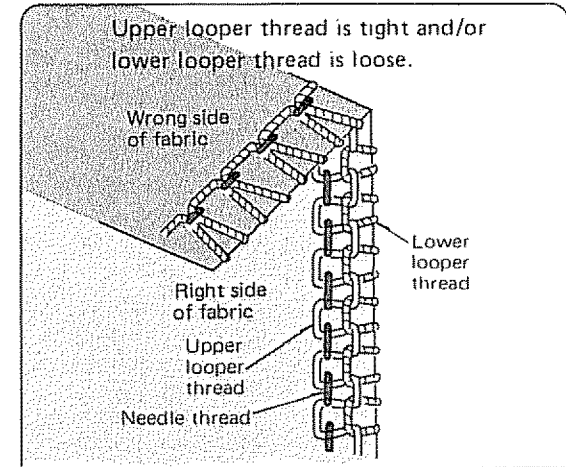

Loosen upper looper thread tension and/or tighten lower looper thread tension.

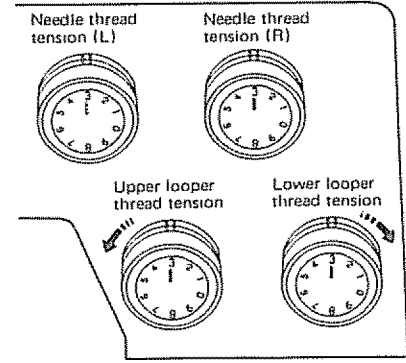

* It is easier to adjust by using 3 different colors of thread.

SECTION 3. LEARN THE STITCHES

Adjustment of Stitch Length

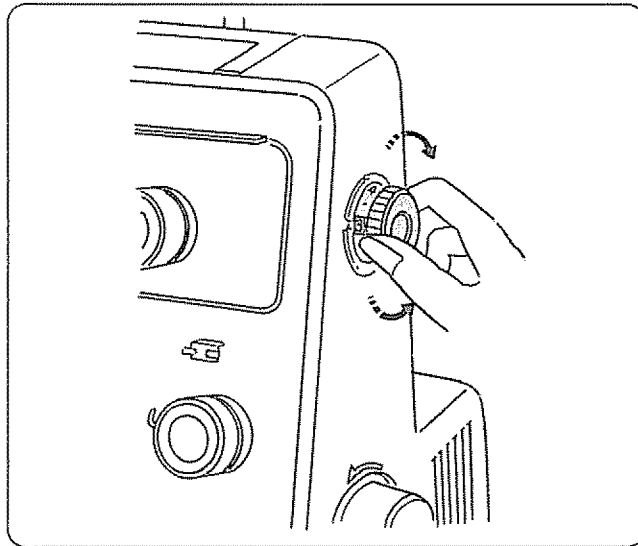

To select stitch length, turn the dial.

The larger the number, the longer the stitch.

The stitch length can be adjusted from 1 to 5 mm, (approx. 5/128" to 25/128").

Position "R" is for rolled and narrow hemmings.

Adjustment of Foot Pressure

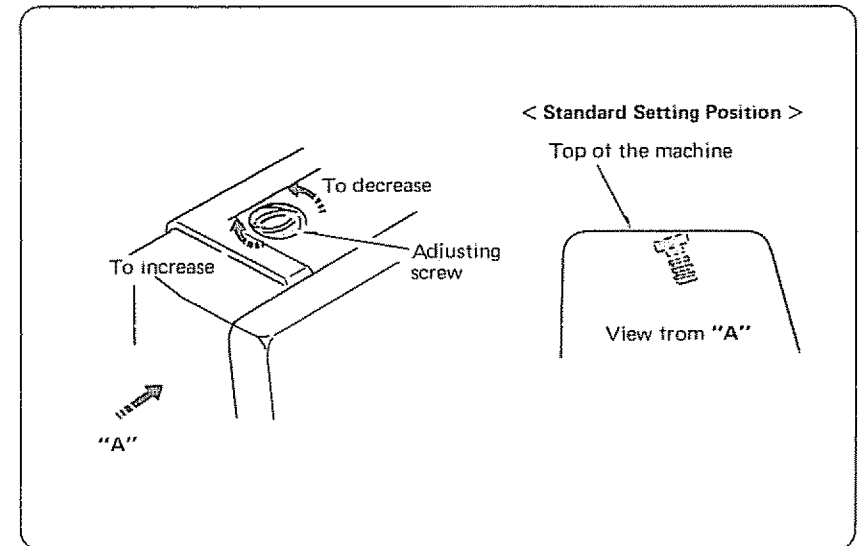

It is not necessary to adjust the pressure for normal sewing.

When you sew heavy or lightweight fabrics, turn the adjusting screw to:

- clockwise for heavyweight fabric.
- counter-clockwise for lightweight fabric.

* For normal sewing, leave the adjusting screw even with the top surface of the machine as illustrated.

Removing the Presser Foot

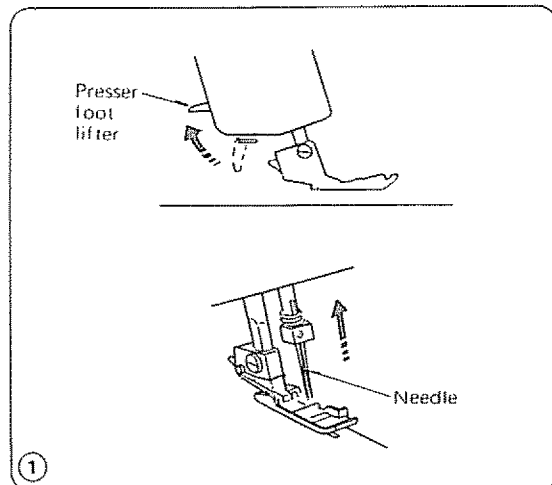

① Raise the needle and presser foot.

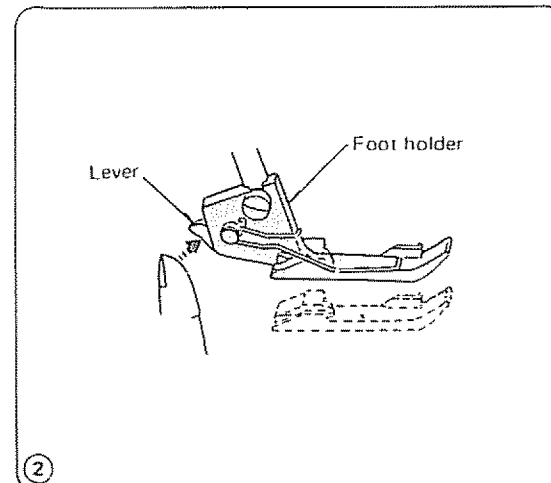

② Press the lever located on the back of foot holder. The presser foot will drop off.

Attaching the Presser Foot

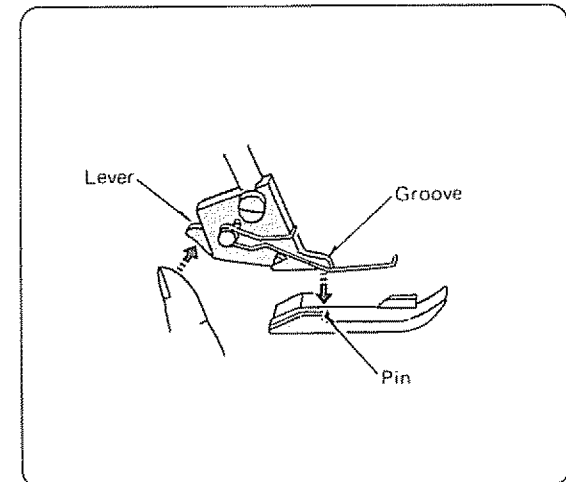

Place the presser foot so that the pin on the foot lies just under the groove of the foot holder. Lower the foot holder and push the lever to lock the foot in place. Raise the presser foot lifter to check that the presser foot is secure.

SECTION 3. LEARN THE STITCHES

Changing Needle

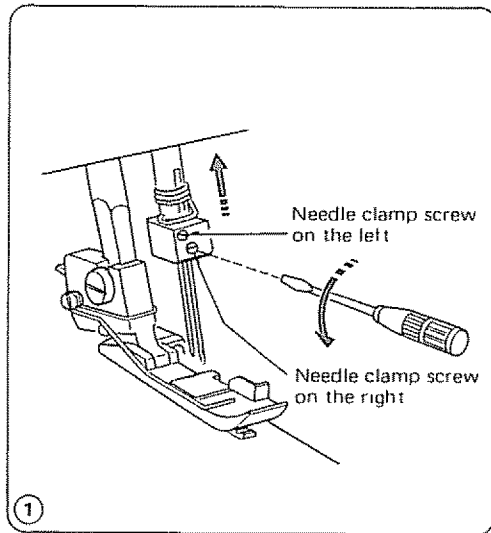

- ① Disconnect the machine from the power supply.
Raise the needle to its highest position.
Then loosen the needle clamp screw for the needle you are going to remove.

Refer to page 24 for changing the needle for three-thread serging.

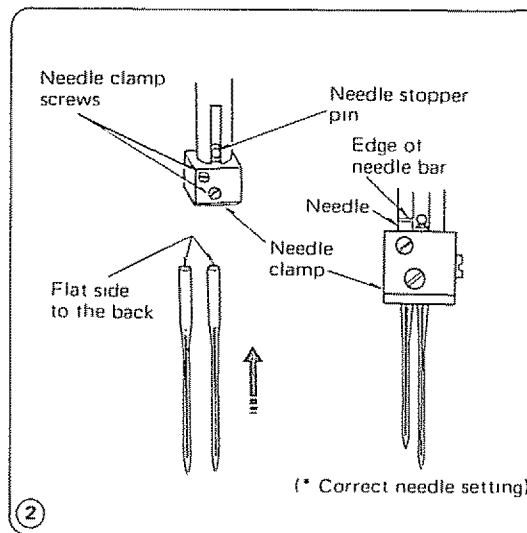

To Attach the needle on the right

Insert new needle into the needle clamp with the flat side to the back until the top of needle touches the stopper pin, then tighten the needle clamp screw on the right.

To attach the needle on the left

Insert new needle into the needle clamp with the flat side to the back until the top of needle touches the edge of needle bar, then tighten the needle clamp screw on the left.

* When the needles are set correctly, the left needle is higher than the right one.

* Do not use any needle which is bent or blunt.

NOTE: Your overlock uses standard Kenmore sewing needles (HA-1 SP, #11, #14). No special needles are required.

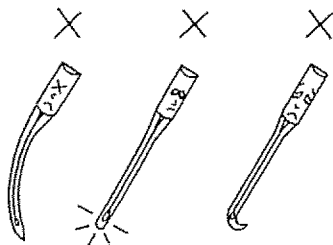

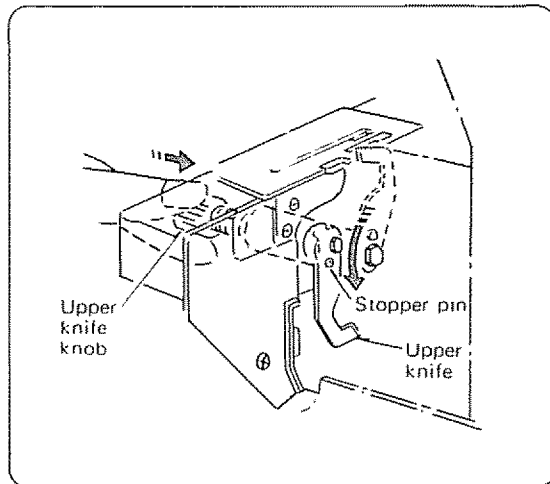
To Disengage the Upper Knife

- ① Disconnect the machine from the power supply.
- ② Open the looper and side covers.
- ③ Turn the upper knife knob toward you while pushing it in to the right, then guide the hole on upper knife to the pin to lock the upper knife in down position.
- ④ Close the looper and side covers.

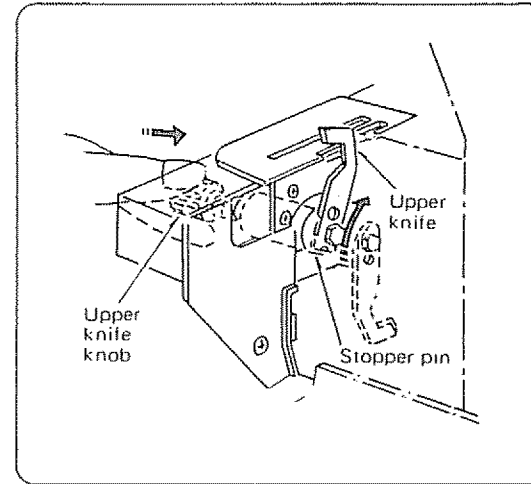
To Engage the Upper Knife

- ① Disconnect the machine from the power supply.
- ② Open the looper and side covers.
- ③ Turn the upper knife knob away from you while pushing it to the right, then guide the groove on upper knife to the pin to lock upper knife in the up position.
- ④ Close the looper and side covers.

SECTION 3. LEARN THE STITCHES

Types of Needle Plates

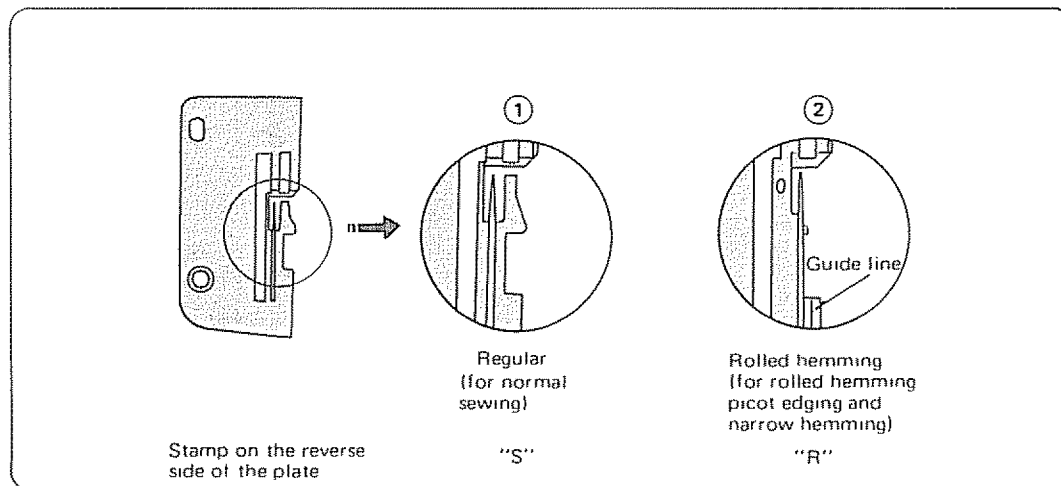

- * Select the needle plate for your sewing need.
- * Your overlock is shipped with the regular needle plate in place.

For your Safety:

When you change the needle plate or adjust the seam width, make sure that the machine is disconnected from the power supply.

Changing the Needle Plate

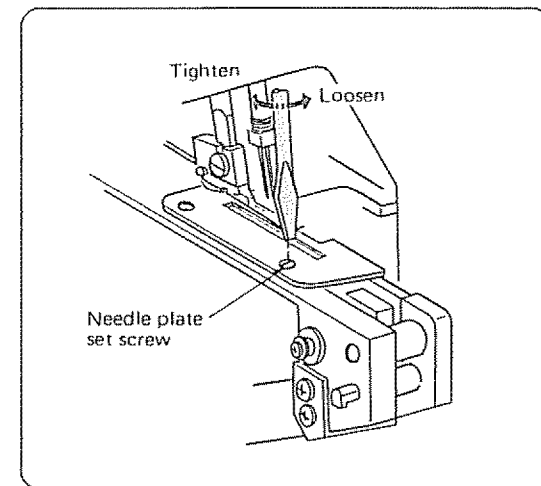

- ① Turn the hand wheel toward you until the needle comes above the needle plate. Then remove the presser foot.
- ② Open the side and looper covers. (Refer to page 6.)
- ③ Set the upper knife to down position. (Refer to page 29.)
- ④ Remove the needle plate set screw, and lift the needle plate.
- ⑤ Attach the needle plate you require with the needle plate set screw.
- ⑥ Bring the upper knife to up position. (Refer to page 29.)
- ⑦ Close the looper and side covers.
- ⑧ Attach the presser foot.

Thread and Needle Chart

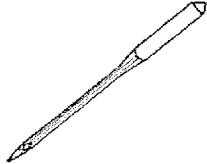
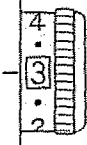
| Type of Fabric | | Type of Thread  | Needle  | Stitch Length  |
|----------------|---|---|---|--|
| Light weight | Organdy, Georgette, Lawn, Crepe de chine, Lining. | Cotton : No. 80 ~ 100 Silk : No. 80 ~ 100 Synthetic : No. 80 ~ 100 | HA-1 SP No. 11 | 2.0 ~ 3.0 |
| Medium weight | Cotton, Linen, Satin, Ordinary fabric. | Cotton : No. 60 ~ 100 Silk : No. 50 ~ 100 Synthetic : No. 60 ~ 100 | HA-1 SP No. 11 ~ 14 | 2.5 ~ 3.5 |
| Heavy weight | Tweed, Coating, Denim, Doeskin, Thick fabric. | Cotton : No. 50 ~ 60 Silk : No. 50 ~ 60 Synthetic : No. 50 ~ 60 | HA-1 SP No. 14 | 3.0 ~ 4.0 |
| Knits | Knitted fabric | Cotton : No. 60 ~ 80 Synthetic : No. 60 ~ 90 Woolly nylon (For looper thread) Woolly polyester (For looper thread) | HA-1 SP No. 11 ~ 14 | 2.5 ~ 3.5 |

* Refer to page 26 for adjusting the stitch length.

NOTE: Your overlock uses standard Kenmore sewing needles (HA-1 SP, #11, #14).

SECTION 3. LEARN THE STITCHES

Rolled Hemming, Picot Edging and Narrow Hemming

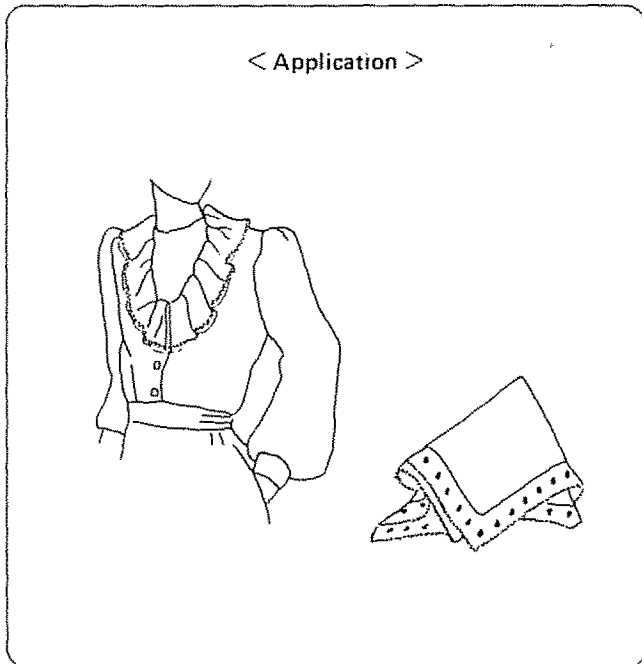

Machine Setting

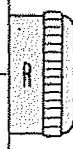
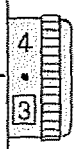
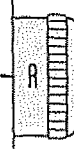
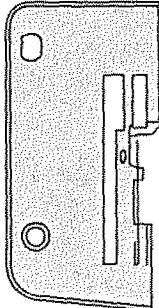
| | Rolled Hemming | Picot Edging | Narrow Hemming |
|---------------|---|--|--|
| Stitch Length |  (R) |  (3 ~ 4) |  (R) |
| Needle | Remove the left needle. | | |
| Needle Plate |  Rolled hemming needle plate. (Marked R on reverse side.) | | |

* Refer to page 30 for changing the needle plate.

Thread, Fabric and Range of the Tension Dial (3 Threads)

Tension dial settings may vary depending on the type and thickness of fabric and thread being used.

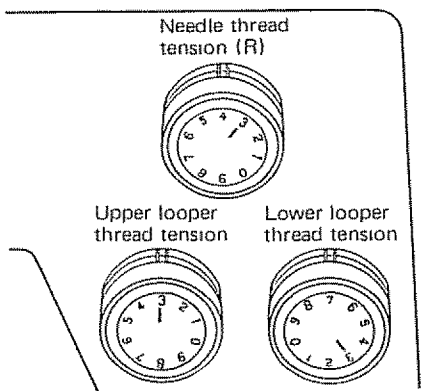
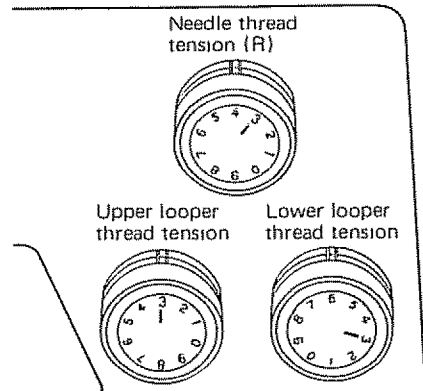
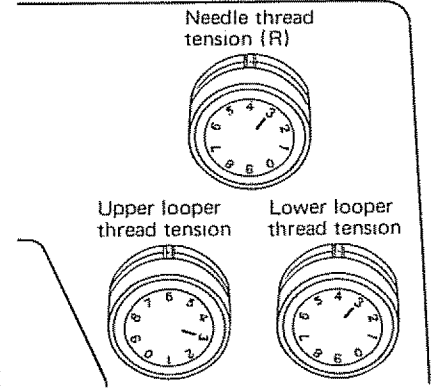
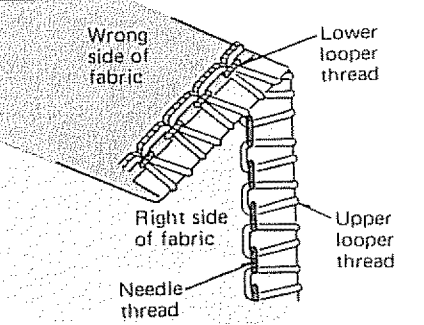
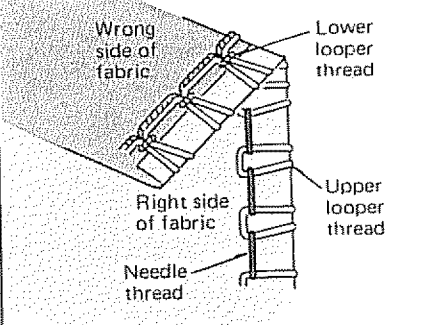
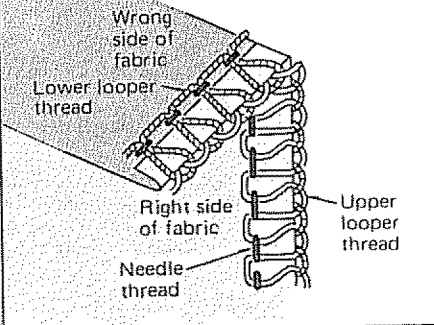
| Fabric | | Rolled Hemming | Picot Edging | Narrow Hemming |
|--|--|---|---|--|
| Lightweight fabric such as organdy, crepe de chine, lawn and georgette | Needle thread | Long fiber polyester thread No. 80 ~ 100 | | |
| | Upper and lower looper threads | Woolly nylon, Woolly polyester | Synthetic 60 ~ 100, Silk No. 50 ~ 100 | Woolly nylon, Woolly polyester |
| | Needle | HA-1 SP No. 11 | | |
| | Standard setting of tension dials |  |  |  |
| Correct thread tension |  |  |  | |

SECTION 3 LEARN THE STITCHES

Rolled Hemming, Picot Edging and Narrow Hemming (continued)

Adjusting Thread Tension

1. Set the tension dials as shown on page 33.
2. Sew and check the tensions.

— For better result —

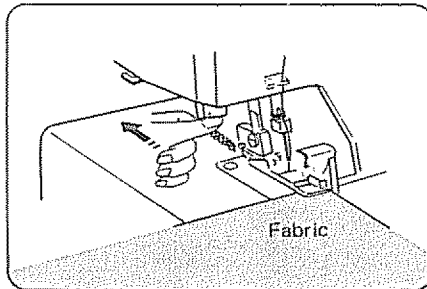

Rolled Hemming

Pull the end of thread chain to the back lightly in the beginning and end of sewing.

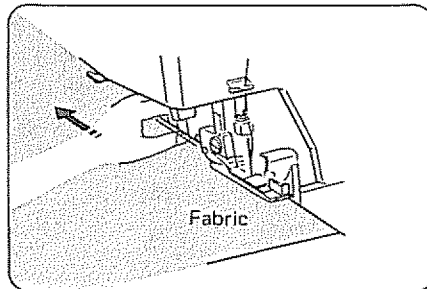

Picot Edging

Pull the fabric lightly to the back while sewing.

How to Adjust the Thread Tension

- For Rolled Hemming and Picot Edging

Wrong Tension

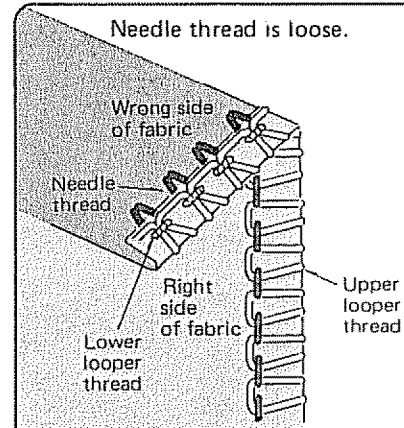

Tighten needle thread tension.

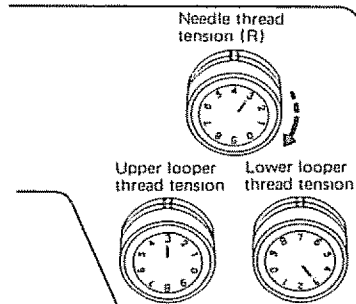

Wrong Tension

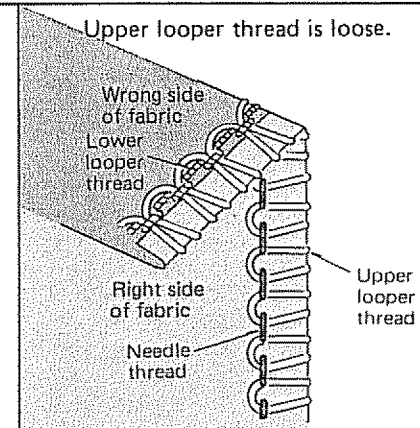

Tighten upper looper thread tension.

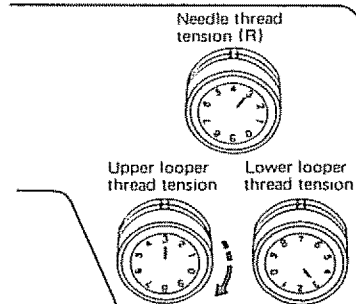

Wrong Tension

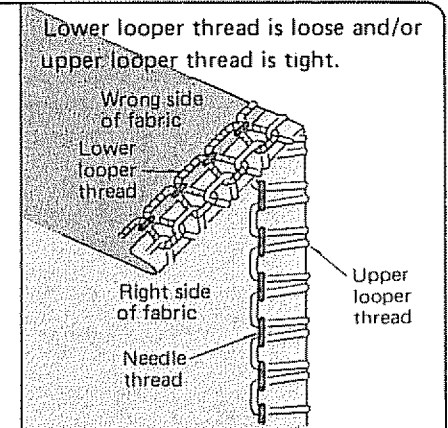

Tighten lower looper thread tension and/or loosen upper looper thread tension.

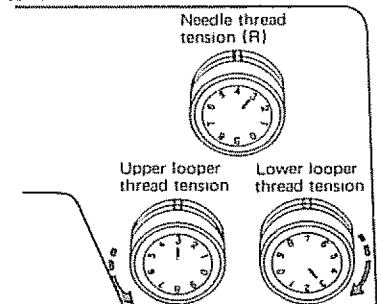

- For Narrow Hemming

Refer to page 25 for the adjustment.

Decorative Overedging

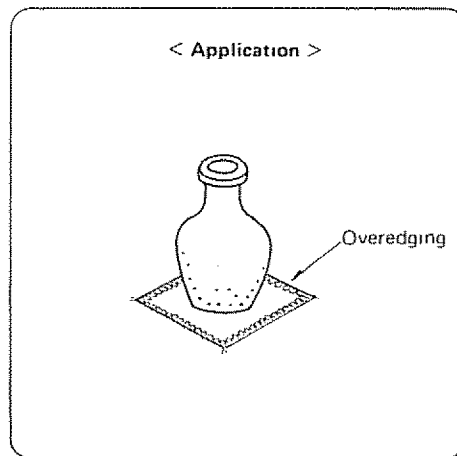

Thread, Fabric, Range of the Tension and Machine Setting

| Fabric | Thread | Standard Setting |
|------------------------|--|--|
| Medium to Heavy Fabric | Needle thread Synthetic : No. 60 ~ 80 Silk : No. 50 ~ 80 | Needle thread tension (L) Needle thread tension (R) |
| | Upper looper thread Buttonhole twist Lightweight wool yarn | Upper looper thread tension Lower looper thread tension |
| | Lower looper thread Synthetic : No. 60 ~ 80 Silk : No. 50 ~ 80 | |
| Machine Setting | Stitch length | 3 ~ 4 |
| | Needle plate | Regular needle plate (Marked S on reverse side) |
| | Needle | HA-1 SP No. 14 |

- * Refer to page 21 for the correct tension.
- * To adjust the thread tension balance, set the tension dials as shown above first, then refer to pages 22 ~ 23.
- * For the best result, pull the thread chain to the back lightly at the beginning and end of sewing.
- * Remove either needle for three thread decorative overedging.

SECTION 3. LEARN THE STITCHES

Pin Tucking

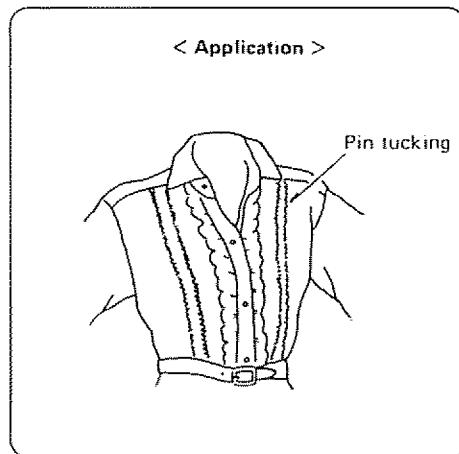

Fabric, Thread and Machine Setting

| Fabric | Thread | |
|--------------------------------|------------------------|---|
| | Light to Medium Fabric | Needle thread on the right |
| Upper and lower looper threads | | Synthetic No. 60 ~ 100 Silk No. 50 ~ 100 |

| | | |
|-----------------|---------------|---|
| Machine Setting | Stitch length | 2 ~ 3 |
| | Needle plate | Regular needle plate (Marked S on reverse side) |
| | Needle | HA-1 SP No. 11 or 14 |

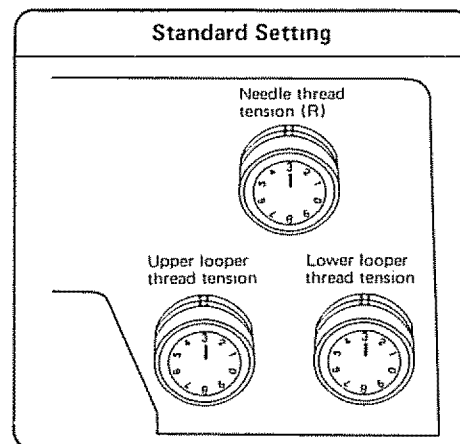

* Refer to pages 24 ~ 25 for thread tension balance adjustment.

Sewing

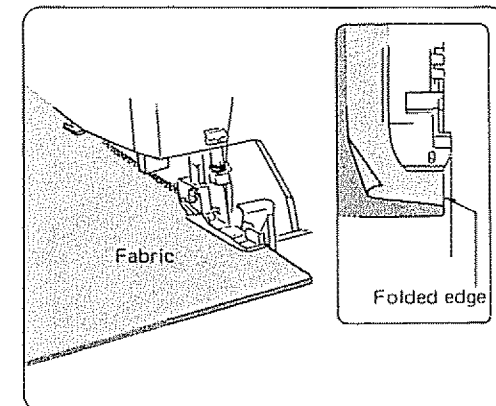

Remove the needle on the left. Disengage the upper knife. (Refer to page 29.)

Sew the folded edge while guiding along the right side edge of lower knife.

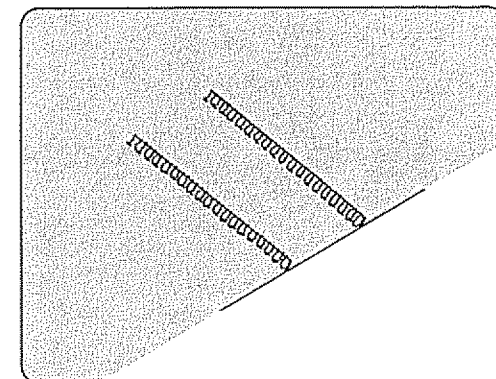

Press the pin tucks to one side.

* Engage the upper knife. (Refer to page 29.)

Cleaning Upper Knife Area

Disconnect the machine from the power supply before cleaning.

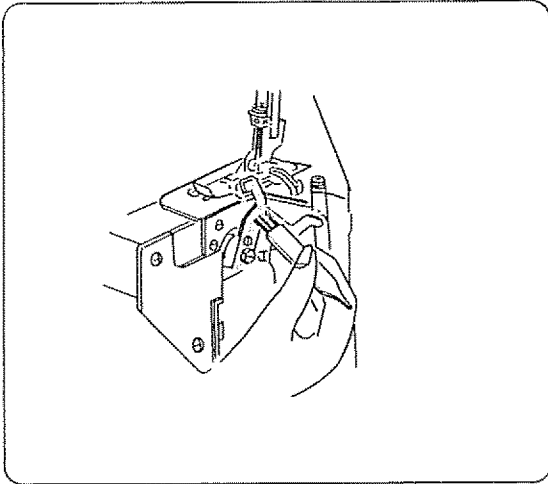

Open the looper cover.
Remove the waste materials with a lint brush.

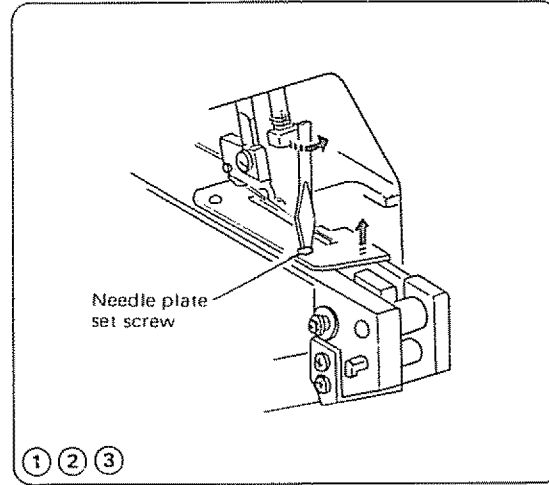
Cleaning the Feed Dog

- ① Open the looper and side covers.
- ② Remove the needles and presser foot.
- ③ Remove the needle plate set screw and needle plate.

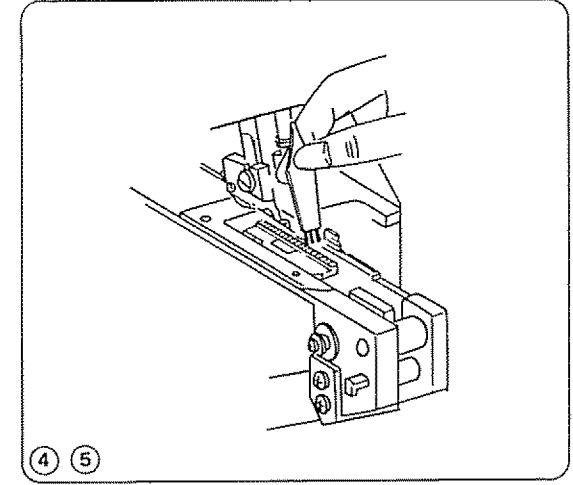

- ④ Push the lint around the feed dog to the front by using lint brush.
- ⑤ Replace needle plate, presser foot and needles. Close the looper and side covers.

* You may use vacuum cleaner to clean the upper knife area or feed dog.

SECTION 4. CARE FOR YOUR MACHINE

Replacing the Light Bulb

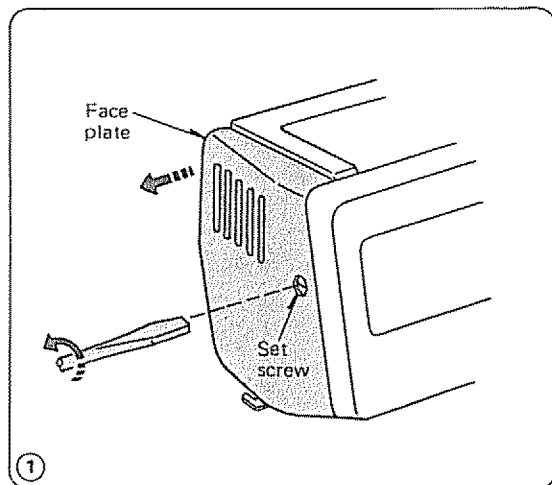

- ① Disconnect the machine from the power supply. Remove the face plate set screw, and remove the face plate.

CAUTION! The light bulb will be HOT. Protect your fingers when you handle it.

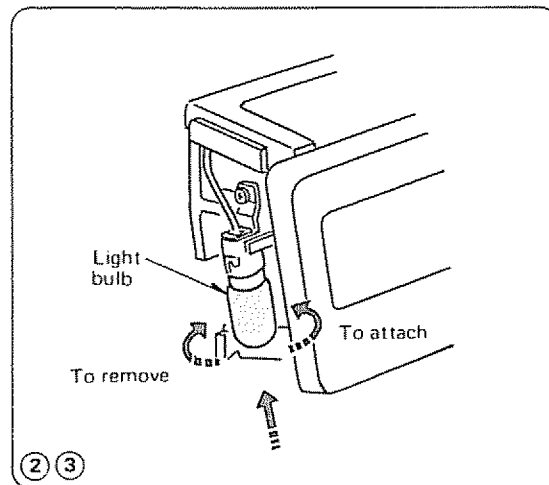

- ② Push the bulb up and turn the bulb counter-clockwise to remove it.
- ③ Put the new bulb in by pushing it up and turning it clockwise.

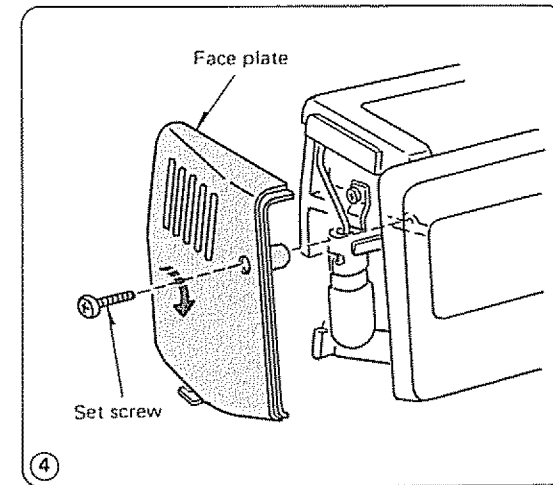

- ④ Attach the face plate, and tighten the face plate set screw.

For your safety:

- * The machine is designed to use a 15 WATT MAXIMUM LIGHT BULB.

Oiling the Machine

Disconnect the machine from the power supply before oiling.

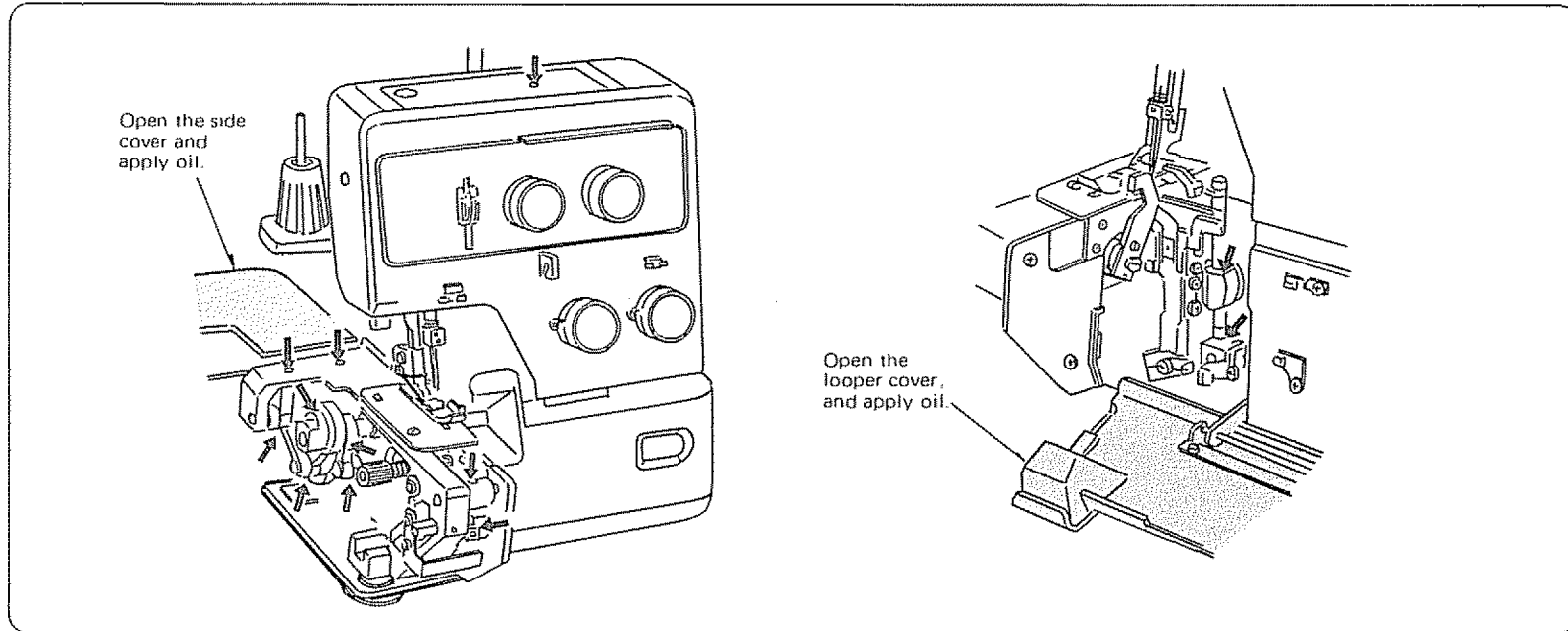

Apply a few drops of fine quality sewing machine oil to the parts indicated with arrows.

Oiling is recommended once a week in normal use, once in ten hours in continuous use.

SECTION 4. CARE FOR YOUR MACHINE

Replacing the Upper Knife

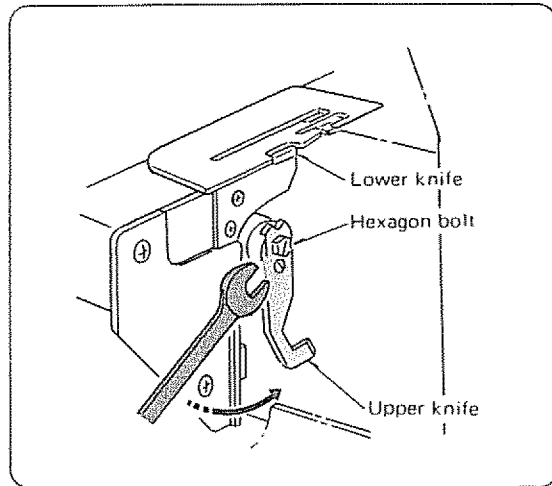

To Remove:

- ① Disconnect the machine from the power supply.
- ② Open the looper and side covers.
- ③ Disengage the upper knife.
(Refer to page 29.)
- ④ Remove the hexagon bolt, and remove the upper knife.

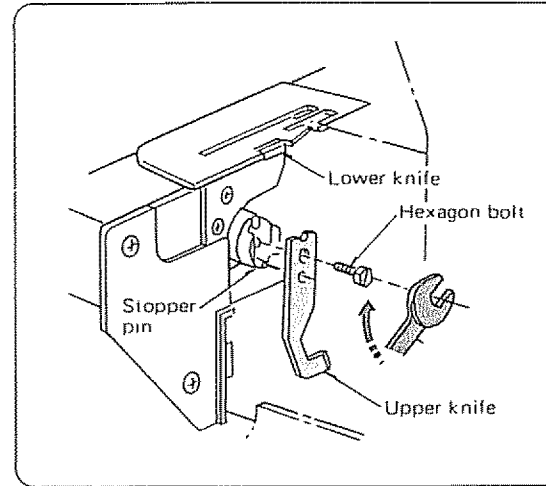

To Attach:

- ① Insert new upper knife into the groove of knife holder and stopper pin, then tighten the hexagon bolt slightly.

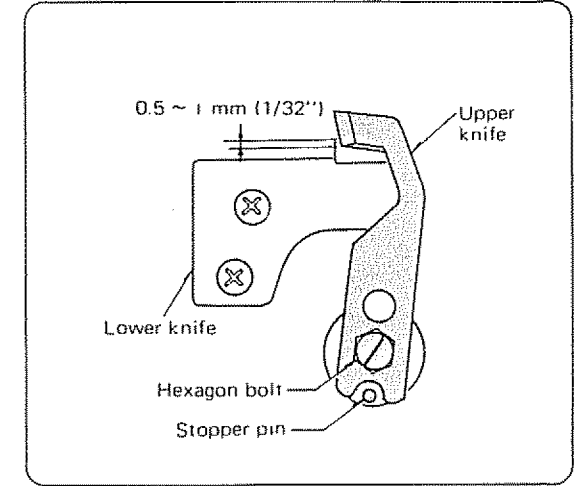

- ② Turn the upper knife holder to cutting position.
- ③ Turn the hand wheel toward you until the upper knife comes to its lowest position. Loosen the hexagon bolt, and adjust the position of upper knife so that the edge of the upper knife overlaps 0.5 to 1 mm (1/32") from the edge of lower knife as shown above. Then tighten the hexagon bolt firmly.
- ④ Close the looper and side covers.

* The lower knife will last over one year in normal use. However, if you run over a pin or a hard object, it may be required to replace both upper and lower knives at the same time.

SECTION 5. PERFORMANCE PROBLEMS CHART

What to Do When

| Condition | Cause | Reference |
|---------------------------------------|--|---|
| The fabric is not being fed smoothly. | <ol style="list-style-type: none"> 1. The feed dog is packed with lint. 2. The presser foot has been raised. | <p>See page 37. Lower the presser foot.</p> |
| The needle breaks. | <ol style="list-style-type: none"> 1. The needle is incorrectly inserted. 2. The needle is bent or blunt. 3. The fabric is forcefully pulled. | <p>See page 28. See page 28. Pull the fabric lightly.</p> |
| The thread breaks. | <ol style="list-style-type: none"> 1. The machine is not correctly threaded. 2. The needle or looper thread tension is too tight. 3. The needle is incorrectly inserted. 4. The needle is bent or blunt. | <p>See pages 9 ~ 17. See pages 21 ~ 25 and 33 ~ 36. See page 28. See page 28.</p> |
| Skipped stitches | <ol style="list-style-type: none"> 1. The machine is not correctly threaded. 2. The needle is bent or blunt. | <p>See page 9 ~ 17. See page 28.</p> |
| The seam is not sewn neatly. | <ol style="list-style-type: none"> 1. The needle and/or looper thread tensions are not correctly adjusted. 2. The machine is not correctly threaded. 3. The needle and/or the thread are not suitable for the fabric being sewn. 4. The thread is not between the tension discs. | <p>See pages 21 ~ 25 and 33 ~ 36. See pages 9 ~ 17. See pages 31, 33, 35 and 36. See pages 11, 13, 15 and 17.</p> |
| Seam puckering. | <ol style="list-style-type: none"> 1. The needle or looper thread tension is too tight. 2. The machine is not correctly threaded. 3. The needle plate is not suitable for the use. | <p>See pages 21 ~ 25 and 33 ~ 36. See pages 9 ~ 17. See page 30.</p> |
| The machine does not operate. | <ol style="list-style-type: none"> 1. The machine has not been plugged in firmly. 2. The power switch is turned off. | <p>See page 5. See page 5.</p> |

PARTS LIST

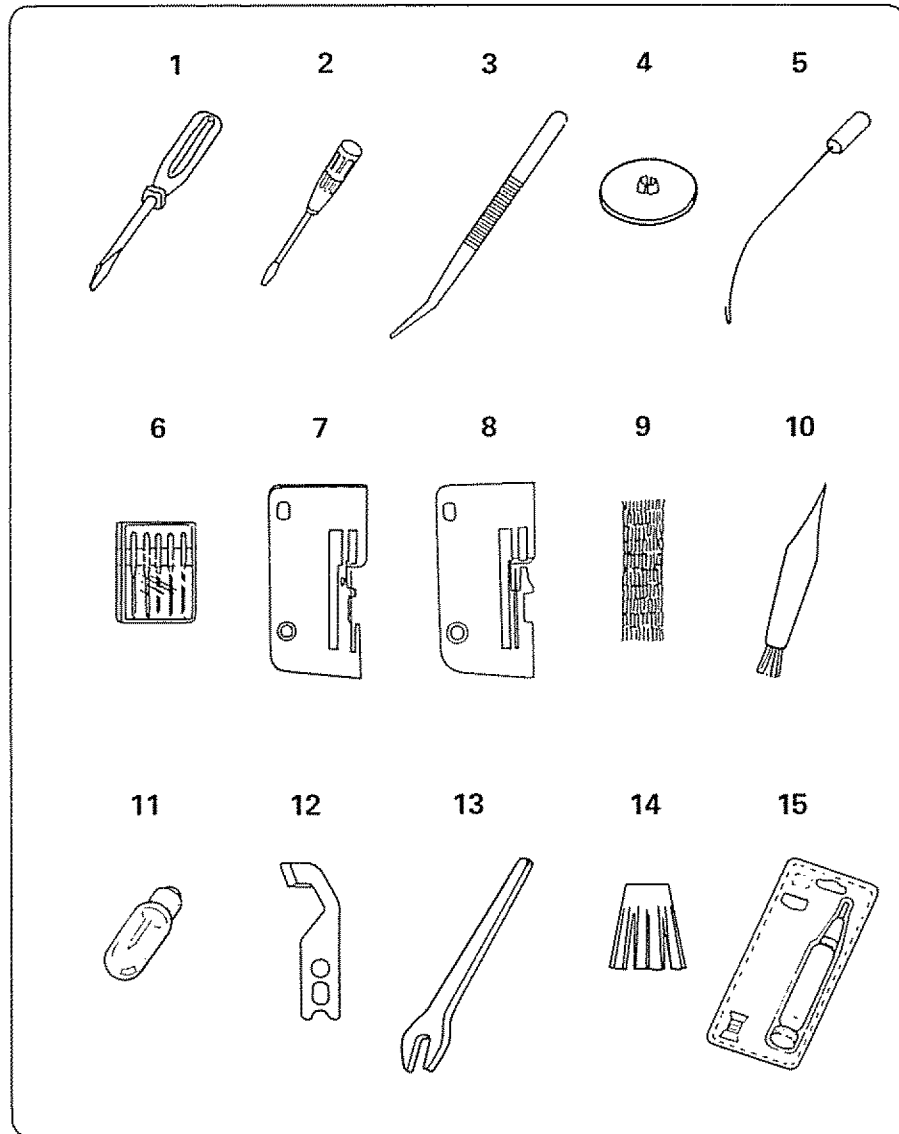

All parts listed herein may be ordered from any Sears store or service center.

WHEN ORDERING REPAIR PARTS, ALWAYS GIVE THE FOLLOWING INFORMATION:

- | | |
|-----------------|---------------------|
| 1. PART NUMBER | 2. PART DESCRIPTION |
| 3. MODEL NUMBER | 4. NAME OF ITEM |

If the parts you need are not stocked locally, your order will be electronically transmitted to a Sears Repair Parts Distribution Center for expedited handling.

| Ref. No. | Part No. | Description |
|----------|------------|-----------------------------|
| 1 | 762402009 | Screw driver (large) |
| 2 | 366413003 | Screw driver (small) |
| 3 | 624801001 | Tweezers |
| 4 | 822020307 | Spool cap |
| 5 | 784806005 | Looper threader |
| 6 | 784860007 | Needle set |
| | 784157004 | Needle, HA-1 SP, No. 11 |
| | 784157015 | Needle, HA-1 SP, No. 14 |
| 7 | 784626009 | Rolled hemming needle plate |
| 8 | 785609009 | Needle plate |
| 9 | 624806006 | Net |
| 10 | 802424004 | Lint brush |
| 11 | 000009803 | Light bulb |
| 12 | 784045019 | Upper knife |
| 13 | *784809008 | Spanner |
| 14 | 784223002 | Spool holder |
| 15 | *6890 | Oil |

* These items are not furnished with the machine, but may be ordered per instructions above.

INDEX

- A**
Accessory box 4
- C**
Carrying handle 3
Changing needle 28
Changing the needle plate 30
- D**
Decorative overedging 35
- F**
Face plate 3, 38
Foot holder 4, 27
Foot holder set screw 4
Foot control 3, 5
- H**
Hand wheel 3, 6
- K**
Knife holder 4
- L**
Light bulb 38, 42
Lint brush 4, 37, 42
Looper thread take-up lever 4, 11, 13
Looper threader 4, 11, 13
Looper cover 3, 6
Lower knife 4
Lower looper 4, 10~11
Lower looper thread 10, 12, 21~25, 33~36
Lower looper thread guide 3, 11
Lower looper thread tension dial 3, 11
- N**
Narrow hemming 32
Needle 27, 28, 31, 42
Needle bar 4
Needle bar thread guide 4, 15, 17
Needle clamp 4, 28
Needle clamp screw 4, 28
Needle plate 4, 30, 42
Needle plate set screw 4, 30, 37
Needle stopper pin 28
Needle threads 14~16, 21~25, 33~36
Needle thread guide 3, 15, 17
Needle thread tension dial
3, 15, 17, 21~25, 33~36
Net 4, 7, 42
- O**
Oiling 39
- P**
Performance problems chart 41
Picot edging 32~34
Pin tucking 36
Plug connector 3, 5
Power switch 3, 5
Pressure adjusting screw 3, 26
Presser bar 4
Presser foot 4, 8, 27
Presser foot lifter 4, 8, 27
- R**
Right needle thread guide 3, 15
Rolled hemming 32
Rolled hemming needle plate 4, 32, 42
- S**
Screwdrivers 4, 42
Side cover 3, 6
Set screw 38
Specification of the machine 44
Spool cap 4, 7, 42
Spool holder 3, 7, 9, 42
Spool pin 3, 7
Spool stand 3
Stitch length dial 3, 26
Stoppers 7
Stopper pin 29
- T**
Thread chain 18
Thread cutter 4, 18
Thread guide bar 3, 7
Thread guide plate 3, 10, 12, 14, 16
Thread take-up lever thread guide 3, 15, 17
Tweezers 4, 11, 42
- U**
Upper knife 4, 29, 42
Upper knife knob 4, 29
Upper looper 4, 12~13
Upper looper thread 12, 21~25, 33~36
Upper looper thread guide 4, 13
Upper looper thread tension dial 3, 13

Specification of the Machine

| Item | Specification |
|-----------------------------|--|
| Sewing speed | 1,300 r.p.m. maximum |
| Stitch length (feed amount) | 1 ~ 5 mm (Ordinary average 3) |
| Overedge stitch width | 3.5 mm or 5.7 mm (3 threads) 5.7 mm (4 threads) |
| Needle bar stroke | 26 mm |
| Presser foot rise | 5 mm |
| Needle | HA-1 SP #11 or #14 |
| Number of threads | 3 or 4 |
| Machine dimensions | width $10\frac{53}{64}$ " x depth $10\frac{5}{32}$ " x height $10\frac{5}{8}$ " |
| Weight | 15.5 lb. |

WARRANTY

FULL FIVE YEAR WARRANTY ON MECHANICAL COMPONENTS OF OVERLOCK MACHINE

For five years from the date of purchase, Sears will, free of charge, repair defects in material and workmanship which appear in the mechanical components of the overlock machine head.

FULL TWO YEAR WARRANTY ON ELECTRICAL EQUIPMENT OF OVERLOCK MACHINE

For two years from the date of purchase, Sears will, free of charge, repair defects in material or workmanship which appear in the electrical equipment of the overlock machine, including electronic components, motor, wiring, switch and speed control.

FULL 90-DAY WARRANTY ON ALL PARTS AND MECHANICAL ADJUSTMENTS

For 90 days from the date of purchase, Sears will, free of charge, replace any parts and provide mechanical service necessary for proper operation of the overlock machine, except for normal maintenance.

WARRANTY SERVICE IS AVAILABLE BY RETURNING THE OVERLOCK MACHINE TO THE NEAREST SEARS SERVICE CENTER/DEPARTMENT IN THE UNITED STATES.

If this overlock machine is used for commercial or rental purposes, the above warranty coverage applies for only 90 days from the date of purchase.

This warranty gives you specific legal rights, and you may also have other rights which vary from state to state.

SEARS, ROEBUCK AND CO., D/817 WA, Hoffman Estates, IL 60179

OVERLOCK

Now that you have purchased your Kenmore Overlock, should a need ever exist for repair parts or service, simply contact any Sears Service Center. Be sure to provide all pertinent facts when you call or visit.

The model number of your Overlock will be shown on your nomenclature plate on the back of your Overlock. See page 3 for location.

WHEN ORDERING REPAIR PARTS, ALWAYS GIVE THE FOLLOWING INFORMATION:

* MODEL NUMBER * NAME OF ITEM * PART DESCRIPTION

If the parts you need are not stocked locally, your order will be electronically transmitted to a Sears Repair Parts Distribution Center for handling.

SEARS, ROEBUCK AND CO., Chicago, IL 60684 U.S.A.
