



Compact Refrigerator

Model 91499
4.9 cu. ft. Capacity

Read This Manual!

It will tell you how to operate and care for your refrigerator. It also offers tips on how to get the best and lowest cost performance.

If you prefer installing your own parts, use the parts list to find the part number. Do not use the illustration number. In the space below record the model and serial number of your refrigerator. Each is printed on the model number plate located in the upper corner of the refrigerator back. Use these numbers when calling for service.

Model No. _____ Serial No. _____

Full One Year Warranty on Refrigerator

For one year from the date of purchase, when this refrigerator is operated and maintained in accordance with the owner's instructions that come with it, Sears will repair it, free of charge, if defective in material or workmanship.

Full One Year Warranty on Sealed Refrigeration System

For one year from the date of purchase, when this refrigerator is operated and maintained in accordance with the owner's instructions that come with it, Sears will repair the sealed system (consisting of refrigerant, connecting tubing and compressor motor), free of charge, if defective in material or workmanship.

The above warranty coverage applies only to refrigerators which are used for the storage of food for private household purposes.

Warranty service is available by contacting the nearest Sears Service Center throughout the United States.

This warranty applies only while this product is in use in the United States. This warranty gives you specific rights and you may also have other rights which vary from state to state.

SEARS, ROEBUCK & CO.

D/817WA, HOFFMAN ESTATES, IL 60179

Installation

Remove all packing material and tape from unit. Inspect unit thoroughly, notify Sears immediately if unit has any damaged or missing parts.

Install unit on a strong level floor or counter. Avoid any direct sunlight, heat source or moisture.

Let air circulate freely around the refrigerator. Keep the back of the unit at least 4 inches away from the wall. Provide at least 1 inch of space between the top of the unit and any surface above it.



CAUTION: If you turn off the cold control, allow at least three minutes before restarting to avoid blowing fuses or tripping your circuit breaker.

Electrical Requirements

120 Volts, 60 Hz (60 cycles AC), 15 amps

Electrical Grounding

Your refrigerator comes with a three-prong plug and must be inserted into a three-prong, grounded wall outlet. Do not use an extension cord.



WARNING: Unless the above grounding method is followed, you are not protected against severe or lethal shock in the event of a short circuit in refrigerator wiring or electrical components.

Things to Remember

1. When resetting your refrigerator to a new temperature, allow 24 hours for it to reach the new setting.
2. The motor will start and stop often. It must do so in order to maintain the temperature you select.
3. Keep your refrigerator level.
4. Unplug the refrigerator before doing anything with the electrical system.

Sears, Roebuck and Co., Hoffman Estates, IL 60179

Parts List

Model: 564.91499100

Use Sears part number on all orders, not the illustration number.

(Please refer to the illustration on the next page.)

Illus. No.	Part No.	Description	Illus. No.	Part No.	Description
1	302697	Foamed door assy.	23	301746	Grommet, compressor mtg.
2	302551	Door gasket, black	24	302261	Compressor
3	302538	Door liner, Snow white	25	302304	Drier
4	302539	Door rack, clear	26	302515	PTC Starter
5	302540	Can dispenser, wire	27	302573	Relay cover
6	302541	Door bar, wire	28	302696	Clip relay cover
7	302542	Door rack bottom, clear	29	302651	Cabinet base plate
8	302543	Top table, plastic	30	301868	Bolt
9	302544	Top support plate, metal	31	300493	Screw
10	302398	Door hinge shaft	32	302548	Power cord, SPT-3
11	302177	Thermo bulb clamp	33	302660	Glass Shelf base
12	301874	Screws	34	302661	Glass Shelf
13	302545	Thermostat, DTB-U426	35	302550	Grommet cap, black
14	302199	Light socket	36	302552	Shelf, glass
15	301021	Indicator lamp, 115 volts	37	302671	Trim
16	302546	Panel thermo	38	302554	Crisper, clear
17	302175	Knob thermo	39	302458	Evaporation/drip tray
18	302192	Light switch	40	301976	Overload relay
19	302426	Bottom hinge	41	302289	Grommet, Comp. Mtg., No hol.
20	302009	Screws	42	302553	Trim Shelf Front
21	301729	Leveling legs	43	302668	Trim Shelf Rear
22	300413	Bolt, compressor mtg.			

PARTS NOT ILLUSTRATED

302662	Owners manual + Parts list + Auxiliary manual
302663	Technical sheet
302664	Mascot
302666	Wiring Diagram

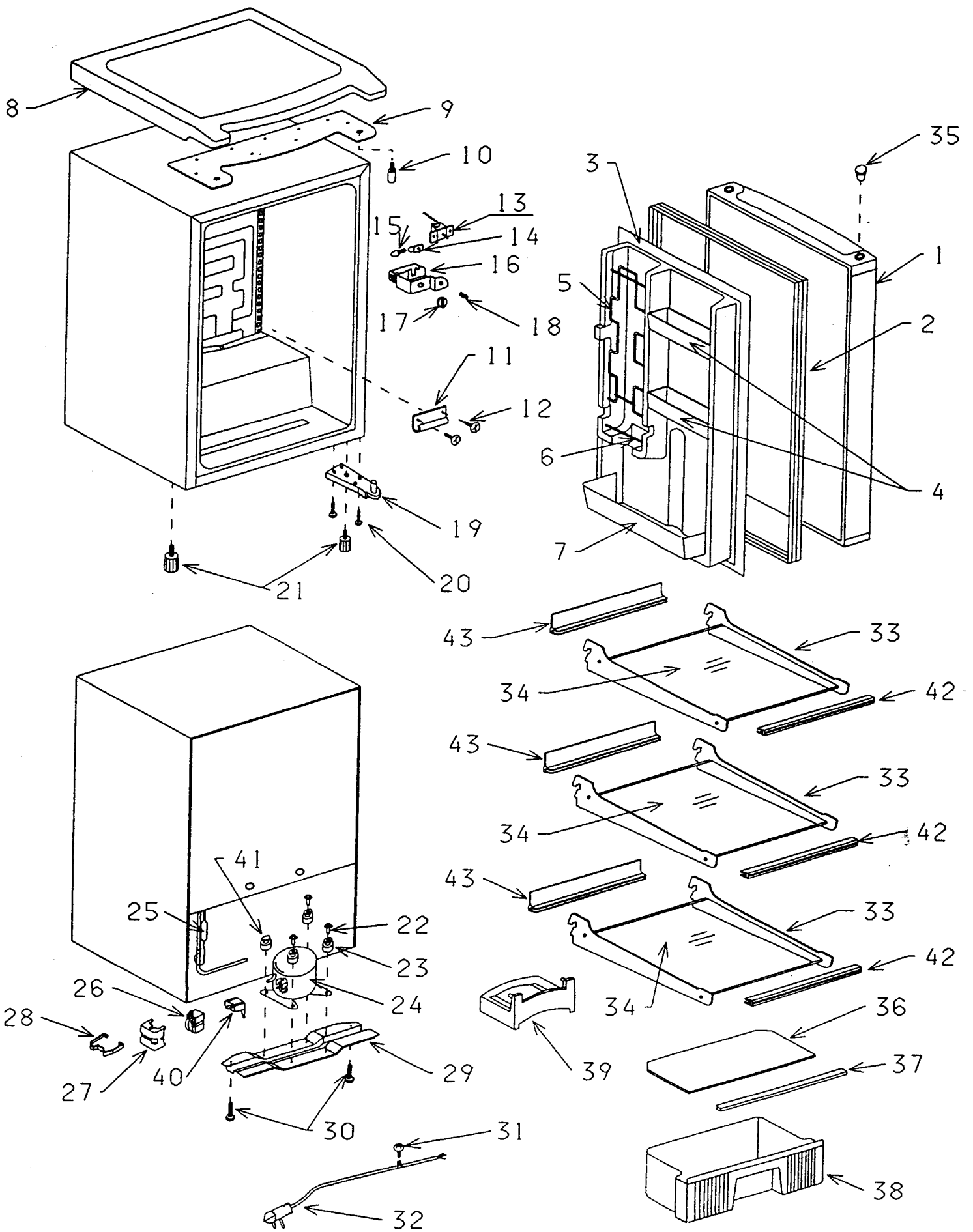

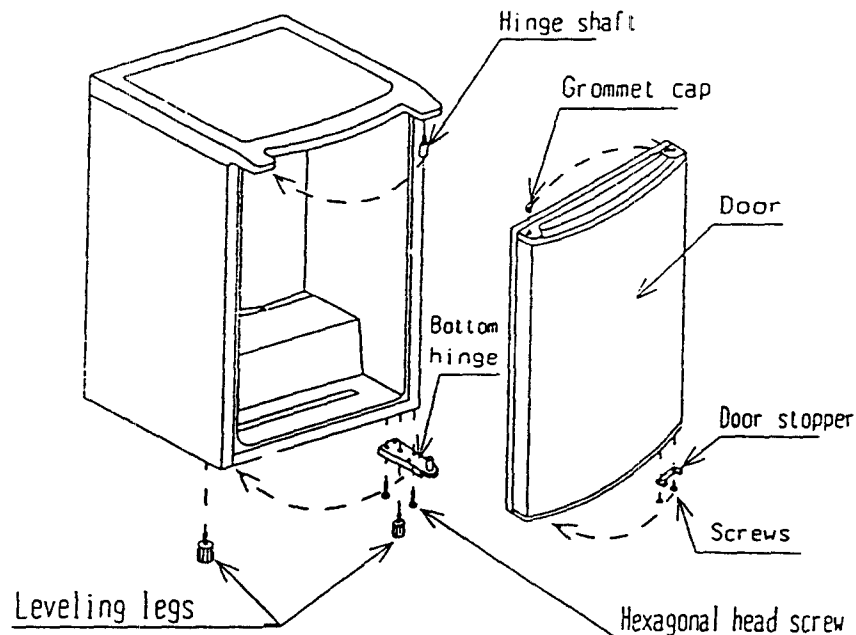

HOW TO TRANSFER THE DOOR HINGE LOCATION OF A REVERSIBLE DOOR

Refer to the disassembly diagram and change the door hinges in the following procedure.

1. Tilt the refrigerator back or lay it on its back. Use a pad or blanket to protect the floor and to avoid scratching the painted finish.
2. Remove the leveling legs by turning them counterclockwise. Remove the lower hexagonal head screws, two on the hinge side and one near the front corner of the other side.
3. Pull the door away from the top table assembly and set the door aside.
4. With a Philips plus screw driver, unscrew the shaft hinge top and transfer to the opposite side.
5. Insert the door back to the shaft hinge top which was screwed unto the opposite side.
6. Remove the refrigerator door hinge stopper and the hinge stopper screws and install them on the other side of the door.
7. Screw the bottom hinge in place ensuring the door is properly secured.
8. Screw the remaining leg to the other side.
9. The direction in which the door opens has now been changed; however, the following points should be checked:
 - a. Make sure the door is on straight.
 - b. Make sure that there is no space between the door gasket and the refrigerator unit itself when the door is closed.
 - c. Make sure that the gasket on the hinge side is not caught between the door and the unit when the door is opened or closed. (If the door is forced closed when the gasket is caught, the gasket may be damaged.)

When checking the above points , if it is discovered that the door is not installed properly (this is apt to happen at the first try), loosen the screws holding the upper hinge, straighten the door and tighten the screws slowly with the socket wrench. After making sure that the door is installed correctly, tighten all the screws holding the hinge.

If they are not tightened, the door may slip out of position or there may be an opening between the door and the unit.

Use and Care Information

Tips on everyday care and use

1. To control the temperature:
First, set the cold control on "3". Wait 24 hours for the entire cabinet to cool. Then adjust the control if necessary. Setting the cold control to min. is the warmest setting; maximum is the coldest. The Max setting may reduce the temperature to below freezing, but it will not cool the refrigerator faster.
2. Defrost:
As long as the Temperature Control is set at normal position, evaporator is automatically defrosted and no manual operation is needed to defrost.
3. For all cleaning:
Mix 2 tablespoons baking soda with 1 quart warm water or use a mild soap. Do not use strong cleaners, scouring powder or pads. For persistent odors, contact Sears Service Center for odor removal products. Do not put the drip tray in the dishwasher.
4. Cleaning the evaporation tray:
Since the dust accumulated on the evaporation tray will decrease the evaporation efficiency, remove the tray to clean.
The evaporation tray is set on the back of the refrigerator. This can be removed by pulling it out from the back of the unit.

Energy Saving tips

1. Close the door as soon as you can after opening it to remove the food. Make sure that the door is fully shut after each use so that cold air doesn't escape from the refrigerator cavity.
2. Adjust the Cold Control. Try a warmer setting. Your refrigerator may be colder than necessary. Use the condition of the milk to check the refrigerator temperature. As long as milk keeps without spoiling your refrigerator is cold enough.

3. Do not place hot foods in the refrigerator.
4. Reduce the number and length of time you open the door. Your cooling system won't have to run as often.
5. Keep your refrigerator level, so that the door seals tightly. When the door is closed, the door gaskets should touch the refrigerator all the way around.
6. If not, make the refrigerator level by use of the adjustable leg located under the unit.
7. Keep the refrigerator away from stoves or other heat sources. A cool and dry place allows your refrigerator to operate more efficiently.

Before calling for service

- Check the plug and fuse.
- Test the outlet with a lamp
- Be sure the control is not set to OFF
- Read the manual, especially the items under Use and Care Information. You may find the answer to your questions.
- If you do not find the answer to your questions in this manual, find the unit model number (on the upper back of the refrigerator) and contact your Sears Service Center.

When requesting or ordering parts, always provide the following information

- Product name
- Model number
- Part name
- Part number



DANGER: ELECTRICAL SHOCK HAZARD
Disconnect power before servicing.

Get fixed, at your home or ours!

Your Home

For repair-in your home-of all major brand appliances, lawn and garden equipment, or heating and cooling system, no matter who made it, no matter who sold it!

For the replacement parts, accessories and owner's manuals that you need to do-it-yourself.

For Sears professional installation of home appliances and items like garage door openers and water heaters.

1-800-4-MY-HOME® (1-800-469-4663)

Call anytime, day or night (U.S.A. and Canada)

www.sears.com www.sears.ca

Our Home

For repair of carry-in items like vacuums, lawn equipment, and electronics, call or go on-line for the location of your nearest Sears Parts & Repair Center.

1-800-488-1222

Call anytime, day or night (U.S.A. only)

www.sears.com

To purchase a protection agreement on a product serviced by Sears:

1-800-827-6655 (U.S.A.)

1-800-361-6665 (Canada)

Para pedir servicio de reparación a domicilio, y para ordenar piezas:

1-888-SU-HOGARSM

(1-888-784-6427)

Au Canada pour service en français:

1-888-LE-FOYER^{MC}

ww.sears.ca

SEARS

® Registered Trademark/™ Trademark/™ Service Mark of Sears, Roebuck and Co.

® Marca Registrada/™ Marca de Fábrica/™ Marca de Servicio de Sears, Roebuck and Co.

™ Marque commerce/™ Marque déposée de Sears, Roebuck and Co.