

Pressure Washer

Operation Manual

for model XR2600

Record All Information and attach sales receipt here for future reference:

Purchase Date: _____

Serial #: _____

Do Not return this product to the retailer!

Questions? 1-800-888-2468

Learn more about your pressure washer,
get answers to frequently asked questions,
and register on line at
www.excellpressurewasher.com



Table of Contents

Safety Guidelines/Definitions	2	Maintenance	12
Consumer Safety Information	2	Storage	13
Important Safety Instructions	2-5	Trouble Shooting Guide	14-15
Carton Contents	6	Warranty	16
Assembly Instructions	6	Español	17-32
Operating Instructions	7-11	Français	33-48

IMPORTANT

Please make certain that the person who is to use this equipment carefully reads and understands these instructions before operating.

SAFETY GUIDELINES - DEFINITIONS

This manual contains information that is important for you to know and understand. This information relates to protecting **YOUR SAFETY** and **PREVENTING EQUIPMENT PROBLEMS**. To help you recognize this information, we use the symbols below. Please read the manual and pay attention to these symbols.

<p>⚠ DANGER Indicates an imminently hazardous situation which, if not avoided, will result in death or serious injury.</p>	<p>⚠ CAUTION Indicates a potentially hazardous situation which, if not avoided, may result in minor or moderate injury.</p>
<p>⚠ WARNING Indicates a potentially hazardous situation which, if not avoided, could result in death or serious injury.</p>	<p>⚠ CAUTION Used without the safety alert symbol indicates a potentially hazardous situation which, if not avoided, may result in property damage.</p>

CONSUMER SAFETY INFORMATION



⚠ WARNING This product may not be equipped with a spark arresting muffler. If the product is not equipped and will be used around flammable materials, or on land covered with materials such as agricultural crops, forest, brush, grass, or other similar items, then an approved spark arrester must be installed and is legally required in the state of California. It is a violation of California statutes section 130050 and/or sections 4442 and 4443 of the California Public Resources Code, unless the engine is equipped with a spark arrester, as defined in section 4442, and maintained in effective working order. Spark arresters are also required on some U.S. Forest Service land and may also be legally required under other statutes and ordinances.



⚠ WARNING Engine exhaust contains chemicals known, in certain quantities, to cause cancer, birth defects or other reproductive harm.

IMPORTANT SAFETY INSTRUCTIONS

⚠ WARNING Do not operate this unit until you have read and understand this Operators Manual and the Engine Owners Manual for Safety, Operation, and Maintenance Instructions.

READ AND SAVE THESE INSTRUCTIONS

HAZARD	
<p>⚠ DANGER RISK OF EXPLOSION OR FIRE</p> <div style="display: flex; justify-content: center; gap: 20px;">   </div>	
WHAT CAN HAPPEN	HOW TO PREVENT IT
<ul style="list-style-type: none"> • Spilled gasoline and its vapors can become ignited from cigarette sparks, electrical arcing, exhaust gases, and hot engine components such as the muffler. • Heat will expand fuel in the tank which could result in spillage and possible fire explosion. • Operating the pressure washer in an explosive environment could result in a fire. 	<ul style="list-style-type: none"> • Shut off engine and allow it to cool before adding fuel to the tank. • Use care in filling tank to avoid spilling fuel. Move pressure washer away from fueling area before starting engine. • Keep maximum fuel level ½" below top of tank to allow for expansion. • Operate and fuel equipment in well ventilated areas free from obstructions. Equip areas with fire extinguisher suitable for gasoline fires.

HAZARD	
 	
⚠ DANGER RISK OF EXPLOSION OR FIRE (continued)	
WHAT CAN HAPPEN	HOW TO PREVENT IT
<ul style="list-style-type: none"> • Materials placed against or near the pressure washer can interfere with its proper ventilation features causing overheating and possible ignition of the materials. • Muffler exhaust heat can damage painted surfaces, melt any material sensitive to heat (such as siding, plastic, rubber, or vinyl), and damage live plants. • Improperly stored fuel could lead to accidental ignition. Fuel improperly secured could get into the hands of children or other unqualified persons. • Use of acids, toxic or corrosive chemicals, poisons, insecticides, or any kind of flammable solvent with this product could result in serious injury or death. • Over inflation of tires could result in serious injury and property damage. 	<ul style="list-style-type: none"> • Never operate pressure washer in an area containing dry brush or weeds. • Always keep pressure washer a minimum of four feet away from surfaces (such as houses, automobiles, or live plants) that could be damaged from muffler exhaust heat. • Store fuel in an OSHA approved container, in a secure location away from work area. • Do not spray flammable liquids. • Use a tire pressure gauge to check the tires pressure before each use and while inflating tires; see the tire sidewall for the correct tire pressure NOTE: Air tanks, compressors, and similar equipment used to inflate tires can fill small tires similar to these very rapidly. Add air in small increments and frequently use the tire gauge to prevent over inflation.

HAZARD	
	
⚠ DANGER RISK TO BREATHING	
WHAT CAN HAPPEN	HOW TO PREVENT IT
<ul style="list-style-type: none"> • Breathing exhaust fumes will cause serious injury or death! Engine exhaust contains carbon monoxide, an odorless and deadly gas. • Some cleaning fluids contain substances which could cause injury to skin, eyes, or lungs. 	<ul style="list-style-type: none"> • Operate pressure washer in a well ventilated area. Avoid enclosed areas such as garages, basements, etc. • Never operate unit in a location occupied by humans or animals. • Use only cleaning fluids specifically recommended for high pressure washers. Follow manufacturers recommendations. Do not use chlorine bleach or any other corrosive compound.

HAZARD	
	
⚠ WARNING RISK OF CHEMICAL BURN	
WHAT CAN HAPPEN	HOW TO PREVENT IT
<ul style="list-style-type: none"> • Use of acids, toxic or corrosive chemicals, poisons, insecticides, or any kind of flammable solvent with this product could result in serious injury or death. 	<ul style="list-style-type: none"> • Do not use acids, gasoline, kerosene, or any other flammable materials in this product. Use only household detergents, cleaners and degreasers recommended for use in pressure washers. • Wear protective clothing to protect eyes and skin from contact with sprayed materials.

HAZARD	
⚠ DANGER RISK TO FLUID INJECTION 	
WHAT CAN HAPPEN	HOW TO PREVENT IT
<ul style="list-style-type: none"> Your washer operates at fluid pressures and velocities high enough to penetrate human and animal flesh, which could result in amputation or other serious injury. Leaks caused by loose fittings or worn or damaged hoses can result in injection injuries. DO NOT TREAT FLUID INJECTION AS A SIMPLE CUT! See a physician immediately! Injuries can result if system pressure is not reduced before attempting maintenance or disassembly. 	<ul style="list-style-type: none"> Never place hands in front of nozzle. Direct spray away from self and others. Make sure hose and fittings are tightened and in good condition. Never hold onto the hose or fittings during operation. Do not allow hose to contact muffler. Never attach or remove wand or hose fittings while system is pressurized. To relieve system pressure, shut off engine, turn off water supply, and pull gun trigger until water stops flowing. Use only hoses and accessories rated for pressure higher than your pressure washer's PSI.

HAZARD	
⚠ WARNING RISK OF ELECTRICAL SHOCK 	
WHAT CAN HAPPEN	HOW TO PREVENT IT
<ul style="list-style-type: none"> Spray directed at electrical outlets or switches, or objects connected to an electrical circuit, could result in a fatal electrical shock. 	<ul style="list-style-type: none"> Unplug any electrically operated product before attempting to clean it. Direct spray away from electric outlets and switches.

HAZARD	
⚠ WARNING RISK OF HOT SURFACES 	
WHAT CAN HAPPEN	HOW TO PREVENT IT
<ul style="list-style-type: none"> Contact with hot surfaces, such as engines exhaust components, could result in serious burn. 	<ul style="list-style-type: none"> During operation, touch only the control surfaces of the pressure washer. Keep children away from the pressure washer at all times. They may not be able to recognize the hazards of this product.

HAZARD	
⚠ DANGER RISK OF INJURY OR PROPERTY DAMAGE WHEN TRANSPORTING OR STORING 	
WHAT CAN HAPPEN	HOW TO PREVENT IT
<ul style="list-style-type: none"> Fuel or oil can leak or spill and could result in fire or breathing hazard, serious injury or death can result. Fuel or oil leaks will damage carpet, paint or other surfaces in vehicles or trailers. 	<ul style="list-style-type: none"> If pressure washer is equipped with a fuel shut-off valve, turn the valve to the off position before transporting to avoid fuel leaks. If pressure washer is not equipped with a fuel shut-off valve, drain the fuel from tank before transporting. Only transport fuel in an OSHA approved container. Always place pressure washer on a protective mat when transporting to protect against damage to vehicle from leaks. Remove pressure washer from vehicle immediately upon arrival at your destination.

HAZARD	
⚠ DANGER RISK OF UNSAFE OPERATION	
WHAT CAN HAPPEN	HOW TO PREVENT IT
<ul style="list-style-type: none"> • Unsafe operation of your pressure washer could lead to serious injury or death to you or others. • If proper starting procedure is not followed, engine can kickback causing serious hand and arm injury. • The spray gun/wand is a powerful cleaning tool that could look like a toy to a child. • Reactive force of spray will cause gun/wand to kickback, and could cause the operator to slip or fall, or misdirect the spray. Improper control of gun/wand can result in injuries to self and others. 	<ul style="list-style-type: none"> • Do not use chlorine bleach or any other corrosive compound. • Become familiar with the operation and controls of the pressure washer. • Keep operating area clear of all persons, pets, and obstacles. • Do not operate the product when fatigued or under the influence of alcohol or drugs. Stay alert at all times. • Never defeat the safety features of this product. • Do not operate machine with missing, broken, or unauthorized parts. • Never leave wand unattended while unit is running. • If engine does not start after two pulls, squeeze trigger of gun to relieve pump pressure. Pull starter cord slowly until resistance is felt. Then pull cord rapidly to avoid kickback and prevent hand or arm injury. • Keep children away from the pressure washer at all times. • Do not overreach or stand on an unstable support. • Do not use pressure washer while standing on a ladder. • Grip gun/wand firmly with both hands. Expect the gun to kickback when triggered.



HAZARD	
⚠ WARNING RISK OF INJURY FROM SPRAY	
WHAT CAN HAPPEN	HOW TO PREVENT IT
<ul style="list-style-type: none"> • High velocity fluid spray can cause objects to break, propelling particles at high speed. • Light or unsecured objects can become hazardous projectiles. 	<ul style="list-style-type: none"> • Always wear ANSI approved Z87 safety glasses. Wear protective clothing to protect against accidental spraying. • Never point wand at, or spray people or animals. • Always secure trigger lock when wand is not in service to prevent accidental operation. • Never permanently secure trigger in pull back (open) position.



CARTON CONTENTS

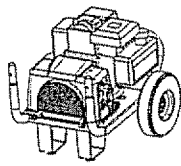

Engine Frame and Wheel Assembly

Operation Manual



Chemical Hose

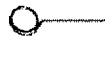

Nozzle Cleaning Tool



Nozzle Holder

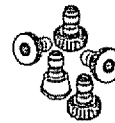

Quick Connect Nozzles

Engine Manual

Registration card

Bagged Parts

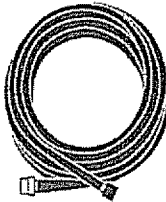

High Pressure Hose

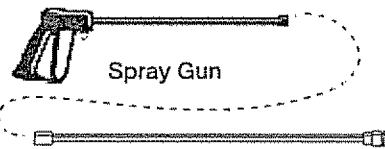

Spray Gun

Quick Connect Spray Wand

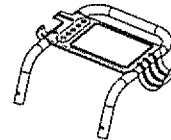

Handle

ASSEMBLY INSTRUCTIONS

- Place handle assembly onto frame, depress the snap buttons, and slide the handle assembly onto the frame until snap buttons snap into place.

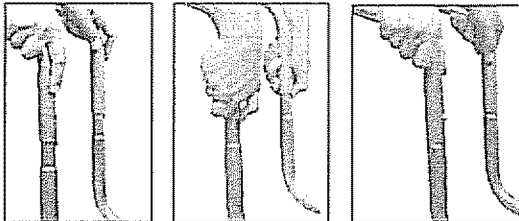

- Attach high pressure hose to gun. Tighten securely.

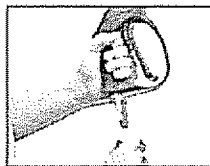

- Connect wand to gun. Tighten securely.

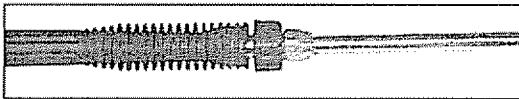

- Place the nozzle holder onto the panel (located on the handle assembly) and push each nozzle holder into place.

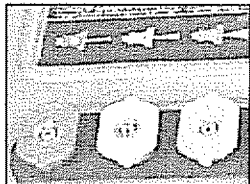
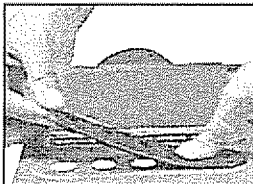

- Remove five colored quick connect nozzles from plastic bag and insert them into correct grommet on the nozzle holder. **NOTE:** Nozzles are color coded to match colored nozzles on panel.

NOTE: The pump on this unit is maintenance free and requires no oil, if there is a problem with the pump contact an Authorized Service Center.

- Use a tire pressure gauge to check the tires pressure before each use and while inflating tires; see the tire sidewall for the correct tire pressure. **NOTE:** Air tanks, compressors, and similar equipment used to inflate tires can fill small tires similar to these very rapidly. Add air in small increments and frequently use the tire gauge to prevent over inflation.

⚠ WARNING Risk of Bursting. Over inflation of tires could result in serious injury and property damage.

OPERATING INSTRUCTIONS

Compare the illustrations with your unit to familiarize yourself with the location of various controls and adjustments. Save this manual for future reference.

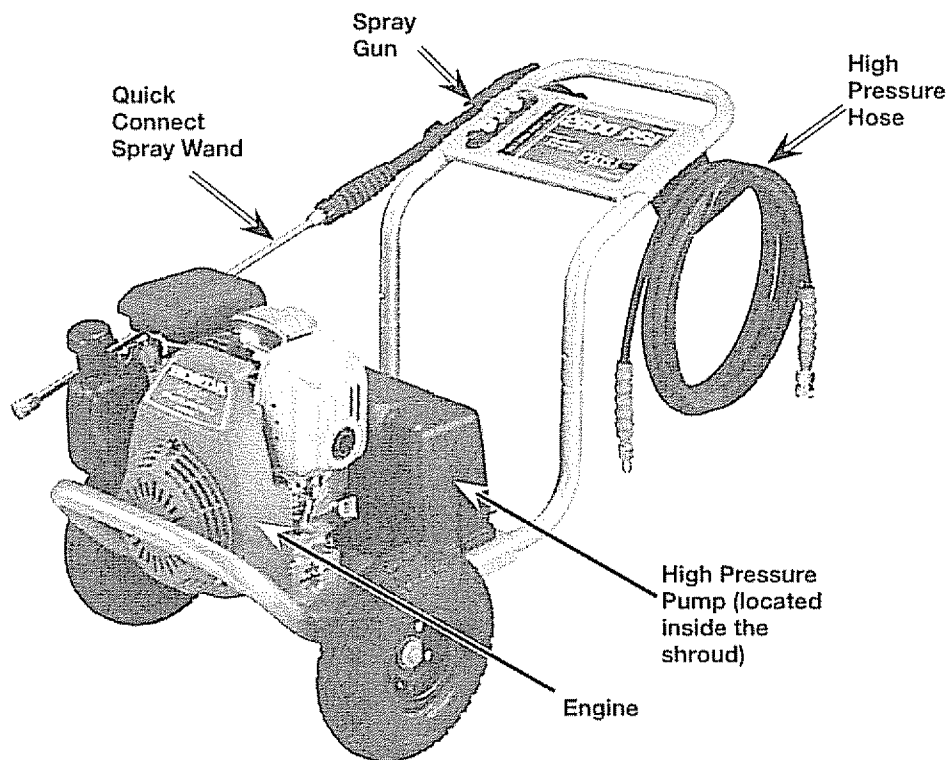

BASIC ELEMENTS OF A PRESSURE WASHER

High Pressure Pump (located inside the shroud): Increases the pressure of the water supply.

Engine: Drives the high pressure pump.

High Pressure Hose: Carries the pressurized water from the pump to the gun and spray wand.

Spray Gun: Connects with spray wand to control water flow rate, direction, and pressure.

Quick Connect Spray Wand: Allows the user to quickly change out high-pressure nozzles. See How To Use Spray Wand instructions in this section.

Chemical Hose (not shown): Feeds cleaning agents into the pump to mix with the water. See How To Apply Chemicals/Cleaning Solvents instructions in this section.

BASIC ELEMENTS OF AN ENGINE

Refer to the engine manual for location and operation of engine controls.

Choke Control: Opens and closes carburetor choke valve.

Starter Grip: Pulling starter grip operates recoil starter to crank engine.

Engine Switch: Enables and disables ignition system.

PRESSURE WASHER TERMINOLOGY

PSI: Pounds per Square Inch. The unit of measure for water pressure. Also used for air pressure, hydraulic pressure, etc.

GPM: Gallons Per Minute. The unit of measure for the flow rate of water.

CU: Cleaning Units. GPM multiplied by PSI. $GPM \times PSI = CU$

Bypass Mode: Allows water to re-circulate within pump when the gun trigger is not pulled.

⚠ CAUTION Allowing the unit to run for more than two minutes without the gun trigger pulled could cause overheating and damage to the pump.

Chemical Injection System: Mixes cleaners or cleaning solvents with the water to improve cleaning effectiveness.

Water Supply: All pressure washers must have a source of water. The minimum requirements for a water supply are 20 PSI and 5 gallons per minute.

PRESSURE WASHER OPERATING FEATURES PRESSURE ADJUSTMENTS

The pressure setting is preset at the factory to achieve optimum pressure and cleaning. If you need to lower the pressure, it can be accomplished by these methods.

1. **Back away from the surface to be cleaned.** The further away you are, the less the pressure will be on the surface to be cleaned.
2. **Change to the 40° nozzle - (white)** this nozzle delivers a less powerful stream of water and a wider spray pattern.

⚠ CAUTION DO NOT attempt to increase pump pressure. A higher pressure setting than the factory set pressure may damage pump.

READ AND UNDERSTAND ALL WARNINGS BEFORE STARTING UNIT

⚠ DANGER When using the high pressure setting, DO NOT allow the high pressure spray to come in contact with unprotected skin, eyes, or with any pets or animals. Serious injury can occur.

Your washer operates at fluid pressures and velocities high enough to penetrate human and animal flesh, which could result in amputation or other serious injury. Leaks caused by loose fittings or worn or damaged hoses can result in injection injuries. **DO NOT TREAT FLUID INJECTION AS A SIMPLE CUT! See a physician immediately!**

⚠ WARNING NEVER fill fuel tank when engine is running or hot. Do not smoke when filling fuel tank.

NEVER fill fuel tank completely. Fill tank to 1/2" below bottom of filler neck to provide space for fuel expansion. Wipe any fuel spillage from engine and equipment before starting engine.

NEVER run engine indoors or in enclosed, poorly ventilated areas. Engine exhaust contains carbon monoxide, an odorless and deadly gas.

DO NOT let hoses come in contact with very hot engine muffler during or immediately after use of your pressure washer. Damage to hoses from contact with hot engine surfaces will NOT be covered by warranty.

⚠ CAUTION NEVER pull water supply hose to move pressure washer. This could damage hose and/or pump inlet.

DO NOT use hot water, use cold water only.

NEVER turn water supply off while pressure washer engine is running or damage to pump will result.

DO NOT stop spraying water for more than two minutes at a time. Pump operates in bypass mode when spray gun trigger is not pressed. If pump is left in bypass mode for more than two minutes internal components of the pump can be damaged.

If you do not understand these precautions, please call 1-800-888-2468 to speak to a service representative for further instructions.

TO USE SPRAY WAND

The nozzles for the spray wand are stored in nozzle holder on the panel assembly. Colors on the panel identify nozzle location and spray pattern. See chart to choose the correct nozzle for the job to be performed.

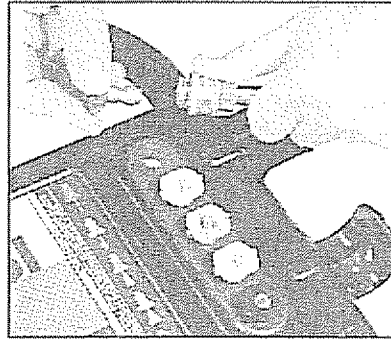

CHANGING NOZZLES ON SPRAY WAND

⚠ WARNING Risk of Flying Object could cause risk of serious injury. **DO NOT** attempt to change nozzles while pressure washer is running. Turn engine off before changing nozzles.

1. Pull quick connect coupler back and insert nozzle.
2. Release quick connect coupler and twist nozzle to make sure it is secure in coupler.

⚠ WARNING Risk of Flying Object could cause risk of serious injury. Ensure nozzle is completely inserted in QC socket, and QC snap ring is fully engaged (forward) before squeezing gun trigger.

⚠ WARNING Risk of injection or injury to person. Do not direct discharge stream toward persons, unprotected skin, eyes, or any pets or animals. Serious injury can occur.

Nozzle Color	Red	Yellow	Green	White	Black
	0°	15°	25°	40°	low pressure
Spray Pattern					
Uses	powerful pinpoint for very intense cleaning	intense cleaning of small areas	intense cleaning of larger areas	covers wide areas of cleaning	applies cleaning solutions
Surfaces *	Metal or concrete DO NOT use on wood	metal, concrete, or wood	metal, concrete, or wood	metal, concrete, wood, or vinyl	metal, concrete, wood, or vinyl

* **⚠ CAUTION** The high pressure spray from your pressure washer is capable of causing damage to surfaces such as wood, glass, automobile paint, auto striping and trim, and delicate objects such as flowers and shrubs. Before spraying, check the item to be cleaned to assure yourself that it is strong enough to resist damage from the force of the spray.

HOW TO APPLY CHEMICALS AND CLEANING SOLVENTS

Applying chemicals or cleaning solvents is a low pressure operation. **NOTE:** Use only soaps and chemicals designed for pressure washer use. **Do not use bleach.**

To Apply chemicals:

1. Press chemical hose onto barbed fitting located near high pressure hose connection of pump as shown.
2. Place other end of chemical hose with filter on it into container holding chemical/cleaning solution. **NOTE:** For every 7 gallons of water pumped 1 gallon of chemical/cleaning solution will be used.
3. Install low pressure (black) nozzle into quick connect fitting of spray wand, see How To Use Spray Wand paragraph in this section.
4. After use of chemicals, place chemical hose into container of clean water and draw clean water through chemical injection system to rinse system thoroughly. If chemicals remain in the pump it could be damaged. Pumps damaged due to chemicals will not be covered under warranty.

NOTE: Chemicals and soaps will not siphon when spray wand is in the high pressure setting.

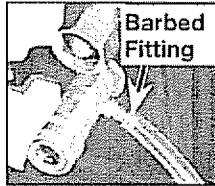

STARTING

Prior to starting, refer to your engine manual for proper starting procedure.

1. In a well ventilated outdoor area add fresh, high quality, unleaded gasoline with a pump octane rating of 86 or higher. Do not overfill. Wipe up spilled fuel before starting the engine. Refer to Engine Owners Manual for correct procedure.
2. Check engine oil level. See Engine Owners Manual for correct procedure.
3. Verify the filter screen is in water inlet of pump. **NOTE:** Cone side faces out.
4. Connect water source to pump inlet. **NOTE:** Water source must provide a minimum of 5 gallons per minute at 20 PSI.
5. Connect high pressure hose to pump outlet.

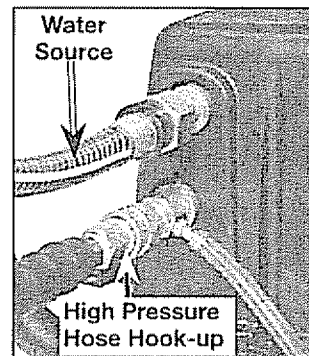
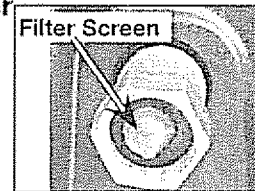

6. If applying a chemical or cleaning solution, see How To Apply Chemicals/Cleaning Solvents instructions in this section.
7. Turn water source on. **NOTE:** Failure to do so could cause damage to the pump.

8. **Start engine.** See Engine Owners Manual for correct procedure. **NOTE:** When engine rope is pulled, pressure starts building in the gun. If the engine does not start after two pulls, pull the gun trigger to relieve this pressure.
9. **Depress trigger on gun to start water flow.** **NOTE:** Stand on a stable surface and grip gun/spray wand firmly with both hands. Expect the gun to kick when triggered.
10. **Release trigger to stop water flow.**
11. **Adjust nozzle spray for the task being performed.** See How To Use Wand instructions in this section.

SHUTTING DOWN

1. **After each use,** if you have applied chemicals, place chemical hose into container of clean water and draw clean water through chemical injection system to rinse system thoroughly. **NOTE:** Failure to do so could cause damage to the pump.
2. **Turn engine off.** See Engine Owner's Manual. **NOTE: NEVER** turn the water off with the engine running.
3. **Turn water source off.**
4. **Pull trigger on spray gun** to relieve any water pressure in hose or spray gun.
5. **See Storage section** in this manual for proper storage procedures.

MAINTENANCE

⚠ WARNING When performing maintenance, you may be exposed to hot surfaces, water pressure, or moving parts that can cause serious injury or death! Before performing any maintenance or repair, disconnect spark plug wire, let engine cool and release all water pressure. The engine contains flammable fuel. **DO NOT** smoke or work near open flames while performing maintenance.

To ensure efficient operation and longer life of your pressure washer, a routine maintenance schedule should be prepared and followed. If the pressure washer is used in unusual conditions, such as high-temperatures or dusty conditions, more frequent maintenance checks will be required.

ENGINE

Consult the Engine Owners Manual for the manufacturer's recommendations for any and all maintenance. Consult the Engine Owners Manual for the manufacturer's recommendations for any and all maintenance. **NOTE:** The frame is equipped with an oil drain hole to help make changing the engine oil easier.

PUMP

The pump on this unit is maintenance free and requires no oil, if there is a problem with the pump contact an Authorized Service Center.

NOZZLE CLEANING

If the nozzle becomes clogged with foreign materials, such as dirt, excessive pressure may develop. If the nozzle becomes partially clogged or restricted, the pump pressure will pulsate. Clean the nozzle immediately using the nozzle kit supplied and the following instructions:

1. Shut off the pressure washer and turn off the water supply.
2. Pull trigger on gun handle to relieve any water pressure.

3. Disconnect the spray wand from the gun.
4. Remove the high-pressure nozzle from the spray wand. Remove any obstructions with the nozzle cleaning tool provided and backflush with clean water.

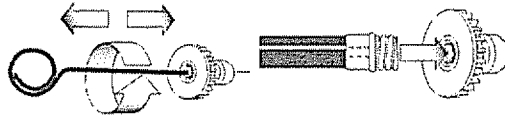

5. Direct water supply into spray wand to backflush loosened particles for 30 seconds.
6. Reassemble the nozzle to the wand.
7. Reconnect spray wand to gun and turn on water supply.
8. Start pressure washer and place spray wand into high pressure setting to test.

HOW TO CLEAN THE WATER INLET FILTER

This screen filter should be checked periodically and cleaned if necessary.

1. **Remove filter** by grasping end and removing it from water inlet of pump as shown.
2. **Clean filter** by flushing it with water on both sides.
3. **Re-insert filter** into water inlet of pump. **NOTE:** Cone side faces out.

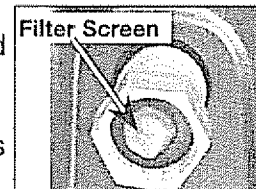

NOTE: Do not operate pressure washer without filter properly installed.

STORAGE

ENGINE

Consult the Engine Owners Manual for the manufacturer's recommendations for storage.

PUMP

The manufacturer recommends using a pump protector/winterizer, such as EXA80, when storing the unit for more than 30 days and/or when freezing temperatures are expected. If a pump protector/winterizer is not available, *RV antifreeze needs to be run through the pump as outlined in the steps below.

NOTE: Using a pump protector/winterizer or *RV antifreeze is to provide proper lubrication to the internal seals of the pump regardless of temperature or environment.

1. Obtain a funnel, six ounces of *RV antifreeze, and 16 - 36 inches of garden hose with a male hose connector attached to one end.

CAUTION Use only RV antifreeze. Any other antifreeze is corrosive and can damage pump.

2. Disconnect spark plug wire.
3. Connect length of garden hose to water inlet of pump.
4. Add *RV antifreeze to hose as shown.

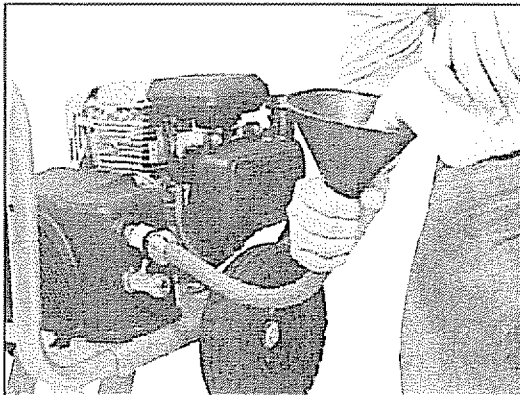

5. Pull engine starter rope slowly several times until antifreeze comes out of high pressure hose connection of pump.
6. Remove garden hose from water inlet of pump.
7. Reconnect spark plug wire.

*Windshield washer fluid may also be used

PRESSURE WASHER

1. Drain all water from high pressure hose, coil it, and store it in cradle of the pressure washer handle.
2. Drain all water from spray gun and wand by holding spray gun in a vertical position with nozzle end pointing down and squeezing trigger. Store in gun holder.
3. Store chemical hose so it is protected from damage.
4. If space is needed, remove handles and replace as shown.

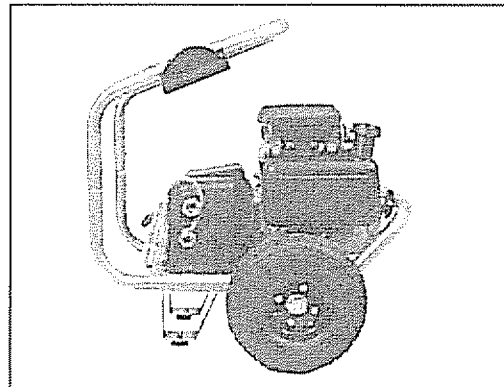

TROUBLE SHOOTING GUIDE

PROBLEM	CAUSE	CORRECTION
<p>Engine will not start (see Engine Manual for further engine troubleshooting)</p>	<p>No fuel.</p> <p>Pressure builds up after two pulls on the recoil starter or after initial use.</p> <p>Choke lever in the "No Choke" position.</p> <p>Spark plug wire not attached.</p> <p>Engine ON/OFF switch in OFF position.</p> <p>Choke lever in the "Choke" position on a "hot" engine or an engine that has been exposed to thermal heat for a long period of time.</p>	<p>Add Fuel.</p> <p>Squeeze gun trigger to relieve pressure.</p> <p>Move choke to the "Choke" position.</p> <p>Attach spark plug wire.</p> <p>Place engine ON/OFF switch in ON position.</p> <p>Move choke to the "No Choke" position.</p>
<p>No or low pressure (initial use)</p>	<p>Spray wand not in high pressure.</p> <p>Low water supply.</p> <p>Leak at high pressure hose fitting.</p> <p>Nozzle obstructed.</p> <p>Water filter screen clogged.</p> <p>Air in hose.</p> <p>Choke lever in the "Choke" position.</p> <p>High pressure hose is too long.</p>	<p>See How to Use Spray Wand instructions in the Operation Section.</p> <p>Water supply must be at least 5 GPM @ 20 PSI.</p> <p>Repair leak. Apply sealant tape if necessary.</p> <p>See Nozzle Cleaning instructions in the Maintenance section.</p> <p>Remove and clean filter.</p> <p>Turn off the engine, then the water source. Disconnect the water source from the pump inlet and turn the water source on to remove all air from the hose. When there is a steady stream of water present, turn water source off. Re-connect water source to pump inlet and turn on water source. Squeeze trigger to remove remaining air</p> <p>Move choke to the "No Choke" position.</p> <p>Use high pressure hose under 100 feet.</p>

PROBLEM	CAUSE	CORRECTION
Will not draw chemicals	<p>Spray wand not in low pressure.</p> <p>Chemical filter clogged.</p> <p>Chemical screen not in cleaning solution.</p> <p>Chemical too thick.</p> <p>Pressure hose is too long</p> <p>Chemical build up in chemical injector.</p>	<p>See How to Use Spray Wand paragraph in the Operation Section.</p> <p>Clean filter.</p> <p>Make sure end of chemical hose is fully submerged into cleaning solution.</p> <p>Dilute chemical. Chemical should be the same consistency as water.</p> <p>Lengthen water supply hose instead of high pressure hose.</p> <p>Have parts cleaned or replaced by AWSC.</p>
No or low pressure (after period of normal use)	<p>Worn seal or packing</p> <p>Worn or obstructed valves.</p> <p>Worn unloader piston.</p>	<p>Have replaced by AWSC.</p> <p>Have replaced by AWSC.</p> <p>Have replaced by AWSC.</p>
Water leaking at gun/ spray wand connection	<p>Worn or broken o-ring.</p> <p>Loose hose connection.</p>	<p>Check and replace.</p> <p>Tighten.</p>
Water leaking at pump	<p>Loose connections.</p> <p>Piston packings worn.</p> <p>Worn or broken o-rings.</p> <p>Pump head or tubes damaged from freezing.</p>	<p>Tighten.</p> <p>Have replaced by AWSC.</p> <p>Have replaced by AWSC.</p> <p>Have replaced by AWSC.</p>
Pump Pulsates	<p>Nozzle obstructed.</p>	<p>See Nozzle Cleaning paragraph in the Maintenance section for the correct procedure.</p>

LIMITED WARRANTY

DeVilbiss Air Power Company warrants to the original purchaser who uses the product in a consumer application (personal, residential or household usage) that all products covered under this warranty are free from defects in material and workmanship for one year from the date of purchase. All products covered by this limited warranty which are used in commercial applications (i.e., income producing) are warranted to be free of defects in material and workmanship for 90 days from the date of original purchase. Products covered under this warranty include air compressors, air tools, service parts, pressure washers, and generators.

DeVilbiss Air Power Company will repair or replace, at DeVilbiss' option, products or components which have failed within the warranty period. Service will be scheduled according to the normal work flow and business hours at the service center location, and the availability of replacement parts. All decisions of DeVilbiss Air Power Company with regard to this limited warranty shall be final.

This warranty gives you specific legal rights, and you may also have other rights which vary from state to state.

RESPONSIBILITY OF ORIGINAL PURCHASER (initial User):

- To process a warranty claim on this product, DO NOT return it to the retailer. The product must be evaluated by an Authorized Warranty Service Center. For the location of the nearest Authorized Warranty Service Center call 1-800-888-2468, 24 hours a day, 7 days a week or visit our web site @ devap.com.
- Retain original cash register sales receipt as proof of purchase for warranty work.
- Use reasonable care in the operation and maintenance of the product as described in the Owners Manual(s).
- Deliver or ship the product to the nearest Authorized Warranty Service Center. Freight costs, if any, must be paid by the purchaser.
- Air compressors with 60 and 80 gallon tanks will be inspected at the site of installation. Contact the nearest Authorized Warranty Service Center that provides on-site service calls for service call arrangements.
- If the purchaser does not receive satisfactory results from the Authorized Warranty Service Center, the purchaser should contact DeVilbiss Air Power Company.

THIS WARRANTY DOES NOT COVER:

- Merchandise sold as reconditioned, used as rental equipment, or floor or display models
- Merchandise that has become damaged or inoperative because of ordinary wear, misuse*, cold, heat, rain, excessive humidity, freeze damage, use of improper chemicals, negligence, accident, failure to operate the product in accordance with the instructions provided in the Owners Manual(s) supplied with the product, improper maintenance, the use of accessories or attachments not recommended by DeVilbiss Air Power Company, or unauthorized repair or alterations.
 - * An air compressor that pumps air more than the recommended duty cycle during a one hour period may be considered misuse.
- Repair and transportation costs of merchandise determined not to be defective.
- Costs associated with assembly, required oil, adjustments or other installation and start-up costs.
- Expendable parts or accessories supplied with the product which are expected to become inoperative or unuseable after a reasonable period of use, including but not limited to sanding disks or pads, saw and shear blades, grinding stones, springs, chisels, nozzles, o-rings, air jets, washers and similar accessories.
- Merchandise sold by DeVilbiss Air Power Company which has been manufactured by and identified as the product of another company, such as gasoline engines. The product manufacturer's warranty, if any, will apply
- **ANY INCIDENTAL, INDIRECT OR CONSEQUENTIAL LOSS, DAMAGE, OR EXPENSE THAT MAY RESULT FROM ANY DEFECT, FAILURE OR MALFUNCTION OF THE PRODUCT IS NOT COVERED BY THIS WARRANTY.** Some states do not allow the exclusion or limitation of incidental or consequential damages, so the above limitation or exclusion may not apply to you.
- **IMPLIED WARRANTIES, INCLUDING THOSE OF MERCHANTABILITY OR FITNESS FOR A PARTICULAR PURPOSE, ARE LIMITED TO ONE YEAR FROM THE DATE OF ORIGINAL PURCHASE.** Some states do not allow limitations on how long an implied warranty lasts, so the above limitations may not apply to you

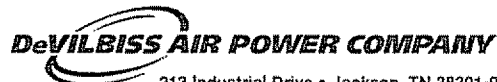

213 Industrial Drive • Jackson, TN 38301-9615
Telephone: 1-800-888-2468
FAX: 1-800-888-9036