

Save This Manual For
Future Reference

SEARS

*owners
manual*

**MODEL NO.
113.239392**

SHAPER WITH STEEL
LEGS AND 1/2 H.P. MOTOR

113.239400

SHAPER WITH STEEL
LEGS AND 3/4 H.P. MOTOR

113.239420

SHAPER WITH STEEL
LEGS AND 1 H.P. MOTOR

Serial
Number _____

Model and serial number may be found
on the front of the table.

You should record both model and
serial number in a safe place for future
use.

**FOR YOUR
SAFETY:**

Read ALL
INSTRUCTIONS
carefully.

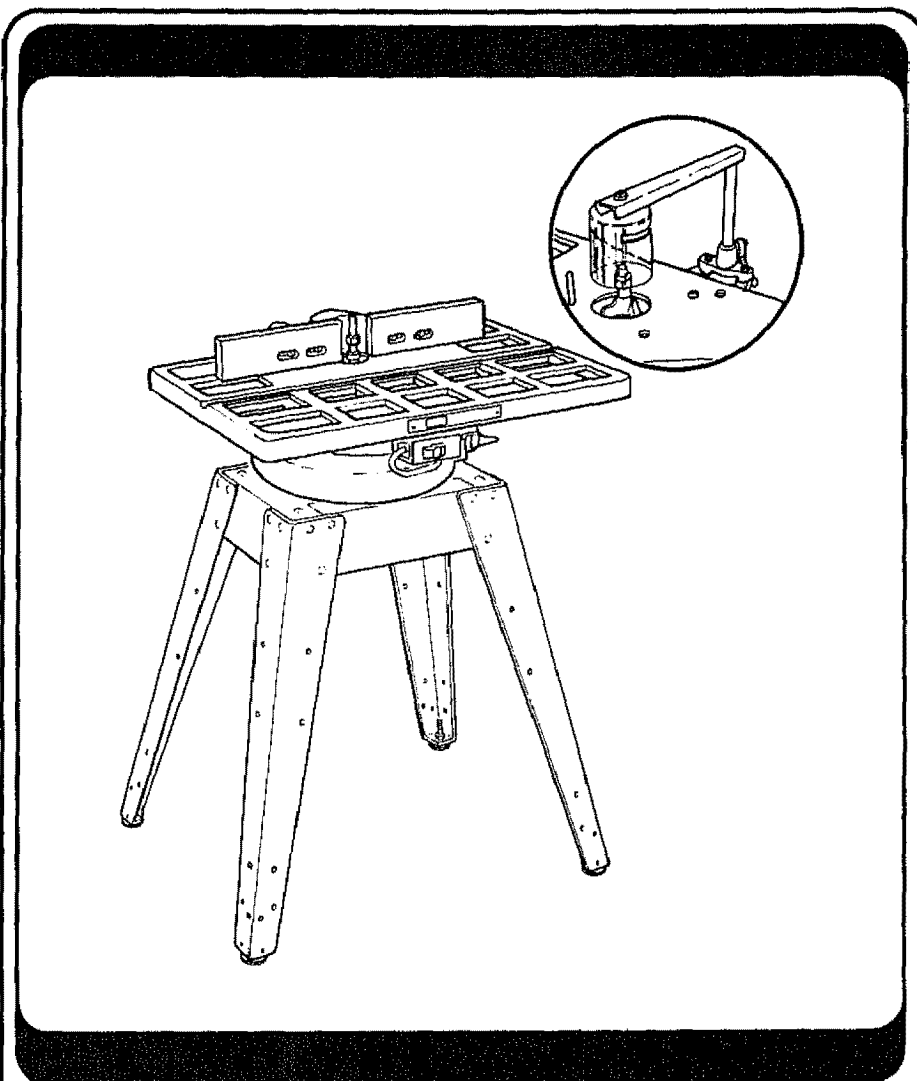

SEARS / CRAFTSMAN

WOOD SHAPER

- *assembly*
- *operating*
- *repair parts*

Sears, Roebuck and Co., Hoffman Estates, IL. 60179 U.S.A.

FULL ONE YEAR WARRANTY ON CRAFTSMAN WOOD SHAPER

If within one year from the date of purchase, this Craftsman Wood Shaper Saw fails due to a defect in material or workmanship, Sears will repair it, free of charge.

WARRANTY SERVICE IS AVAILABLE BY SIMPLY CONTACTING THE NEAREST SEARS SERVICE CENTER/DEPARTMENT THROUGHOUT THE UNITED STATES.

This warranty applies only while this product is used in the United States.

This warranty gives you specific legal rights, and you may also have other rights which vary from state to state.

Sears, Roebuck and Co., D/817 WA Hoffman Estates, IL. 60179

GENERAL SAFETY INSTRUCTIONS FOR POWER TOOLS

1. KNOW YOUR POWER TOOL

Read and understand the owner's manual and labels affixed to the tool. Learn its application and limitations as well as the specific potential hazards peculiar to this tool.

2. GROUND ALL TOOLS

This tool is equipped with a approved 3-conductor cord and a 3-prong grounding type plug to fit the proper grounding type receptacle. The green conductor in the cord is the grounding wire. Never connect the green wire to a live terminal.

3. KEEP GUARDS IN PLACE

In working order, and in proper adjustment and alignment.

4. REMOVE ADJUSTING KEYS AND WRENCHES

Form habit of checking to see that keys and adjusting wrenches are removed from tool before turning it on.

5. KEEP WORK AREA CLEAN

Cluttered areas and benches invite accidents. Floor must not be slippery due to wax or sawdust.

6. AVOID DANGEROUS ENVIRONMENT

Don't use power tools in damp or wet locations or expose them to rain. Keep work area well lighted. Provide adequate surrounding work space.

7. KEEP CHILDREN AWAY

All visitors should be kept a safe distance from work area.

8. MAKE WORKSHOP CHILD-PROOF

With padlocks, master switches, by removing starter keys, or storing tools where children can't get them.

9. DON'T FORCE TOOL

It will do the job better and safer at the rate for which it was designed.

10. USE RIGHT TOOL

Don't force tools or attachment to do a job it was not designed for.

11. WEAR PROPER APPAREL

Do not wear loose clothing, gloves, neckties, or jewelry (rings, wrist watches) to get caught in moving parts. NONSLIP footwear is recommended. Wear protective hair covering to contain long hair. Roll long sleeves above the elbow.

12. USE SAFETY GOGGLES (HEAD PROTECTION)

Wear safety goggles (must comply with ANSI Z87.1) at all times. Everyday eyeglasses are not safety glasses.

They only have impact resistant lenses. Also, use face or dust mask if cutting operation is dusty, and ear protectors (plugs or muffs) during extended periods of operation.

13. SECURE WORK

Use clamps or a vise to hold work when practical. It frees both hands to operate tool.

14. DON'T OVERREACH

Keep proper footing and balance at all times.

15. MAINTAIN TOOLS WITH CARE

Keep tools sharp and clean for best and safest performance. Follow instructions for lubricating and changing accessories.

16. DISCONNECT TOOLS

Before servicing; when changing accessories such as blades, bits, cutters, etc.

17. AVOID ACCIDENTAL STARTING

Make sure switch is in "OFF" position before plugging in.

18. USE RECOMMENDED ACCESSORIES

Consult the owner's manual for recommended accessories. Follow the instructions that accompany the accessories. The use of improper accessories may cause hazards.

19. NEVER STAND ON TOOL OR ITS STAND

Serious injury could occur if the tool is tipped or if the cutting tool is accidentally contacted. Do not store materials above or near the tool such that it is necessary to stand on the tool or its stand to reach them.

20. CHECK DAMAGED PARTS

Before further use of the tool, a guard or other part that is damaged should be carefully checked to ensure that it will operate properly and perform its intended function. Check for alignment of moving parts, binding or moving parts, breakage of parts, mounting, and any other conditions that may affect its operation. A guard or other part that is damaged should be properly repaired or replaced.

21. NEVER LEAVE TOOL RUNNING UNATTENDED

Turn power off. Don't leave tool until it comes to a complete stop.

22. DIRECTION OF FEED

Feed work into a blade or cutter against the direction of rotation of the blade or cutter only.

Additional Safety Instructions for Wood Shaper

Safety Signal Words

DANGER: means if the safety information is not followed someone will be seriously injured or killed.

WARNING: means if the safety information is not followed someone could be seriously injured or killed.

CAUTION: means if the safety information is not followed someone might be injured.

CAUTION: Turn motor switch "OFF" and disconnect Power Cord when changing Shaper cutters or making adjustments.

Safety is a combination of operator common sense and alertness at all times when the Wood Shaper is being used.

WARNING: For your own safety, do not attempt to operate your wood shaper until it is completely assembled and installed according to the instructions... and until you have read and understand the following:

PAGE

1. General Safety Instructions for Power Tools 2
2. Getting to Know your Wood Shaper 12
3. Basic Wood Shaper Operation 15
4. Maintenance 19
5. Stability of Machine

The Shaper must be bolted securely to a stand or work bench, in addition, if there is any tendency for the Shaper to tip over or move during certain operations, it should be bolted to the floor.

6. Location

The Shaper should be positioned so neither the operator nor a casual observer is forced to stand in line with the workpiece when straight line shaping. This Shaper is intended for indoor use only.

7. Protection: Eyes, Hands, Face, Ears, Body

Wear safety goggles that comply with ANSI Z87.1 1968. Wear ear plugs or muffs during extended periods of operation. Do not wear gloves ... roll long sleeves above the elbow.

8. Always feed against rotation of the cutter. NEVER "back up" the workpiece.

9. Do not take deep cuts or feed the stock too rapidly.

10. Be particularly careful in shaping wood that contains cross grains or knots, as these may cause the hands to be thrown into the cutter or cause kickbacks.

11. Before applying power, make sure the keyed washer is installed immediately under the spindle nut and the spindle nut is securely fastened, and all guards are in the proper position. Make sure cutters are sharp.

12. Avoid awkward hand positions, where a sudden slip could cause a hand to move into the cutter. Never reach in back of or around the cutter with either hand to hold down the workpiece.

13. Accumulations of stock or of finished work should not be allowed on the table. Never clear table while cutter is rotating.

14. Rubbish, shavings, stock, or other objects or material should not be allowed on the floor where they may be a tripping hazard.

15. Use working forms, patterns or holders wherever possible, and keep them maintained. Care should be taken that the work is securely fastened in these fixtures. Stock is often of such size or shape that it must be clamped in a holder before being shaped, The inside jaws which clamp directly against the stock should be lined with sand paper. Guards may also be mounted on a holder to afford additional protection.

16. When the fence is used, make sure it is securely fastened and will not slip, and is properly adjusted.

17. Do not wear gloves, neckties, loose sleeves, or ragged or torn clothing of any kind. Wear safety goggles complying with ANSI Z87.1-1968 to protect your eyes from dust or flying particles.

18. DO NOT perform layout, assembly, or set-up work on the table while the cutting tool is rotating.

19. NEVER perform freehand shaping - Use either the fence, or a starting pin in the table and a collar on the spindle, or a pattern.

20. Do not place your fingers or hands near edge of material being cut.

21. NEVER perform irregular shaping operations with the cutter guard removed. Be positive it is installed and adjusted per instructions.

22. NEVER perform internal shaping operations on this Shaper.

23. Do not use your hands to remove objects or materials from around cutters; use a brush.

24. Do not tamper with guards nor make them inoperative in any way.

25. ALWAYS joint or plane edge on surface of workpiece that will be in contact with fence and/or table.

26. NEVER attempt to shape warped or twisted or bowed workpieces.

27. Before leaving the machine, make sure the motor switch is "OFF" the power cord is disconnected from the power source, and the cutter has stopped revolving.

28. Never operate the Shaper without a protective cover on the unused shaft end of a double ended motor.

29. If any part of this Shaper should break, bend, or fail in any way or any electrical component fail to perform properly, or if any is missing, shut off power switch, remove power supply cord from power supply and replace damaged missing and/or failed parts before resuming operation.

WARNING: Do not allow familiarity (gained from frequent use of your wood shaper) to become commonplace. Always remember that a careless fraction of a second is sufficient to inflict severe injury.

30. Note and follow Safety Instructions that appear on the Shaper fence.

WARNING
A KEYED WASHER MUST ALWAYS
BE USED UNDER THE SPINDLE NUT

UNPACKING AND CHECKING CONTENTS

CONTENTS

WARRANTY	2
General Safety Instruction for Power Tools	2
Additional Safety Instructions for Wood Shaper	3
Motor Specifications and Electrical Requirements	4
UNPACKING AND CHECKING CONTENTS	5
List of Loose Parts	5
ASSEMBLY	6
Tools Needed	6
Installing Elevating Rod and Table Support	7
Mounting Belt Guard and Motor to Motor Mount ..	7
Installing Motor Pulley	8
Mounting Motor Support Assembly to Shaper	9
Mounting Switch Assembly	9
Assembling Steel Legs	9
Mounting Wood Shaper on Floor Stand	10
Plugging in Motor	10
Installing Shaper Fence — For Straight Edge Shaping only	11
Installing Shaper Cutter Guard — For Curved or Irregular Shaping only	11
GETTING TO KNOW YOUR WOOD SHAPER	12
On-Off Switch	12
Elevating Control Lever	13
Spindle Lock Knob	13
Spindle	13
Spacers	13
Keyed Washer	13
Fence Adjusting Knob	13
Fence Lock Knob	13
Fence Faces	13
Cutter Guard	13
Starting Pin	13
Removing and Installing Cutter	13
ADJUSTMENTS	14
Shaper Fence	14
Fence Faces	14
BASIC SHAPING OPERATIONS	15
Use of Cutter Spacers	15
Straight Edge Shaping	16
Shaping With Use of Miter Gauge and Hold-Down Clamp (Optional Accessory)	16
Irregular or curved Shaping	17
MAINTENANCE	19
LUBRICATION	19
Motor Maintenance and Lubrication	19
RECOMMENDED ACCESSORIES	19
TROUBLE SHOOTING	20
REPAIR PARTS	22
Motor Connections	27

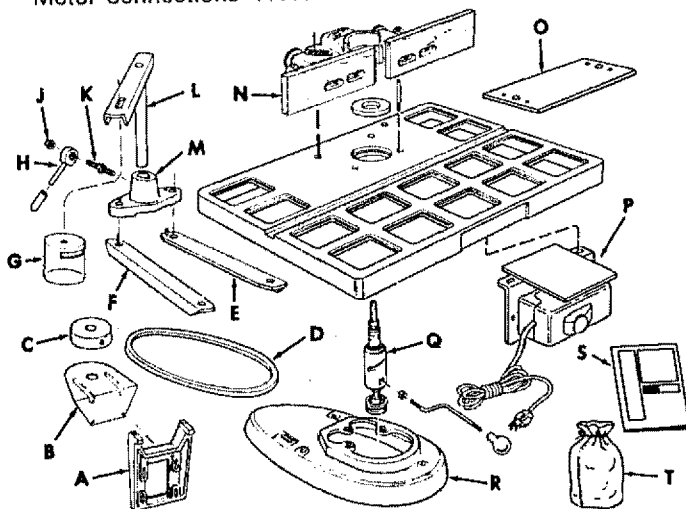

Model 113.239392 and 113.239400 Wood Shapers are shipped complete in one carton and include steel legs and motor. Separate all parts from packing materials and check each one with the illustration and the list of Loose Parts to make certain all items are accounted for, before discarding any packing material.

If any parts are missing, do not attempt to assemble the Shaper, plug in the power cord or turn the switch on until the missing parts are obtained and are installed correctly.

Remove the protective oil that is applied to the table top and edges of the table. Use any ordinary household type grease and spot remover.

CAUTION: Never use gasoline, naphtha or similar highly volatile solvents.

Apply a coat of automobile wax to the table.

Wipe all parts thoroughly with a clean, dry cloth.

WARNING: For your own safety, never connect plug to power source outlet until all assembly steps are complete, and you have read and understand the safety and operational instructions.

LIST OF LOOSE PARTS

Included with Model No. 113.239392, 113.239400 and 113.239420

Item	Part Name	Qty.
A	Motor Mount	1
B	Guard, Pulley	1
C	Pulley, Motor	1
D	Belt, "V" 1/2 x 33	1
E	Support Assembly, R.H.	1
F	Support, Assembly L.H.	1
G	Guard, Cutter	1
J	Nut, Lock	1
K	Stud, Nut	1
L	Support, Guard	1
M	Bracket, support	1
N	Fence Assembly	1
O	Plate, Guard	1
P	Switch Box Assembly	1
Q	Spindle Assembly	1
R	Base	1
S	Owner's Manual	1
T	Bag Assembly, Loose Parts	

Loose Parts Box #508181		
	Screw Hex Hd. 3/8-16 x 1	2
	Washer, .380 x 19/64 x 7/64	2
	Bolt, Carriage 5/16-18 x 1-1/4	4
	Washer, 21/64 x 7/8 x 1/8	4
	Screw, w/Lockwasher, 5/16-18 x 3/4	3
	Washer, 11/32 x 1-1/16 x 1/8	2
	Screw, Hex Hd. 5/16-18 x 1-1/4	3
	Nut, Hex 5/16-18	7
	Lockwasher, Int. 5/16	3
	Washer, 21/64 x 3/4 x 1/16	5
Loose Parts Bag #508415		
	Starting Pin	1
	Insert, Table	1
	Wrench	1
	Wrench, Hex "L" 5/32	1
	Wrench, Hex "L" 1/4	1
	Knob	1
	Nut, Hex Jam 3/8-24	1
	Hanger, Cable	1
	Screw, Hex Hd. 5/16-18 x 2	2
	Elevating Rod	1
	Screw, Soc. Set 5/16-18 x 5/16	1

LIST OF LOOSE PARTS

Item	Part Name	Qty.
A	Leg	4
B	* Screw, Truss Hd. 1/4-20 x 5/8	28
C	* Nut, Hex 1/4-20	28
D	* Lockwasher, 1/4 External	28
E	Channel, Support	2
F	Stiffener	2
G	Stiffener, Side	2
H	Stiffener, End	2
J	* Screw, Pan Hd. Ty A N8 x 1/2	4
K	* Nut, Hex Hd. 3/8-16	8
L	* Foot, Leveling	4
M	Motor	1

HARDWARE FOR MOUNTING TOOL

-	* Screw, Hex Hd. 5/16-18 x 3	3
-	* Lockwasher, 5/16 External	3
-	* Nut, Hex Jam, 5/16-18	3
-	* Washer, 11/32 x 11/16 x 1/16	3

- These parts contained in Loose Part bag #508411.

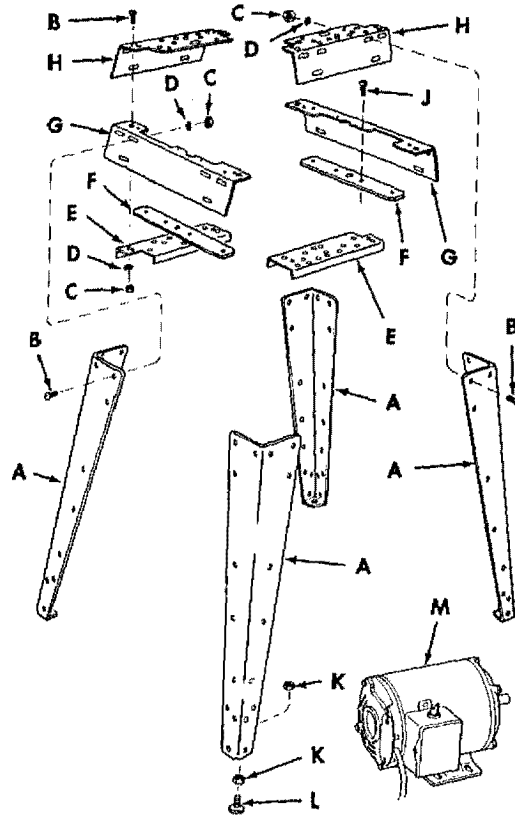

ASSEMBLY

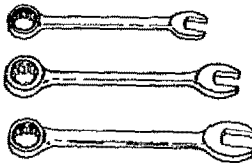

7/16-INCH WRENCH
1/2-INCH WRENCH
9/16-INCH WRENCH

TOOLS NEEDED

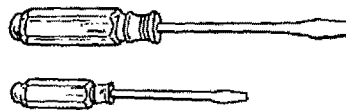

SCREWDRIVER (MEDIUM)
SCREWDRIVER (SMALL)

FRAMING SQUARE

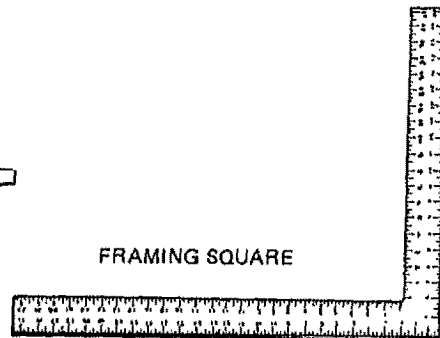

Coat the spindle assembly with cup grease, being sure to wipe some of the grease into the elevating slot milled in the spindle assembly. Use a generous amount of grease to cover the spindle.

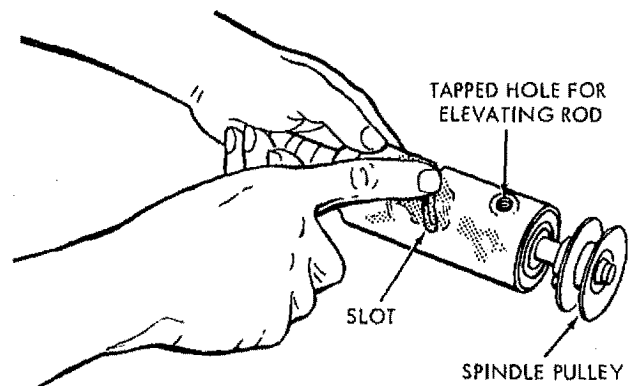

INSTALLING ELEVATING ROD AND TABLE SUPPORT

Position table upside down on 2 x 4's on edge for support and clearance for spindle assembly.

1. Install (3/8-24) jam nut on short threaded end of elevating rod and screw the rod into the threads in the side of spindle assembly.
2. Remove spindle lock knob. Insert the spindle assembly into the table support, position the long angle of the elevating rod straight down and tighten jam nut securely. The angle portion of elevating rod must be parallel with spindle assembly.
3. Install knob on end of elevating rod.
4. Rotate the set screw into the table support, while moving the elevating rod back and forth, until the dog point on end of set screw enters the elevating slot in spindle assembly. This can be felt as the set screw and spindle assembly are rotated. Tighten the set screw, then back it off 1/4 turn. This will allow enough clearance for the spindle assembly slot to slide on dog-point end of set screw.
5. Check operation of spindle several times, by moving elevating control lever back and forth in order to make sure it is not binding, yet slides effectively on the dog-point end of screw. Readjust set screw slightly, if required, for smooth operation.
Reinstall spindle lock knob.
6. Position shaper base on table support casting so the three mounting holes are aligned. Install and tighten the three 5/16-18 x 3/4-inch hex-head screws with lock washers.

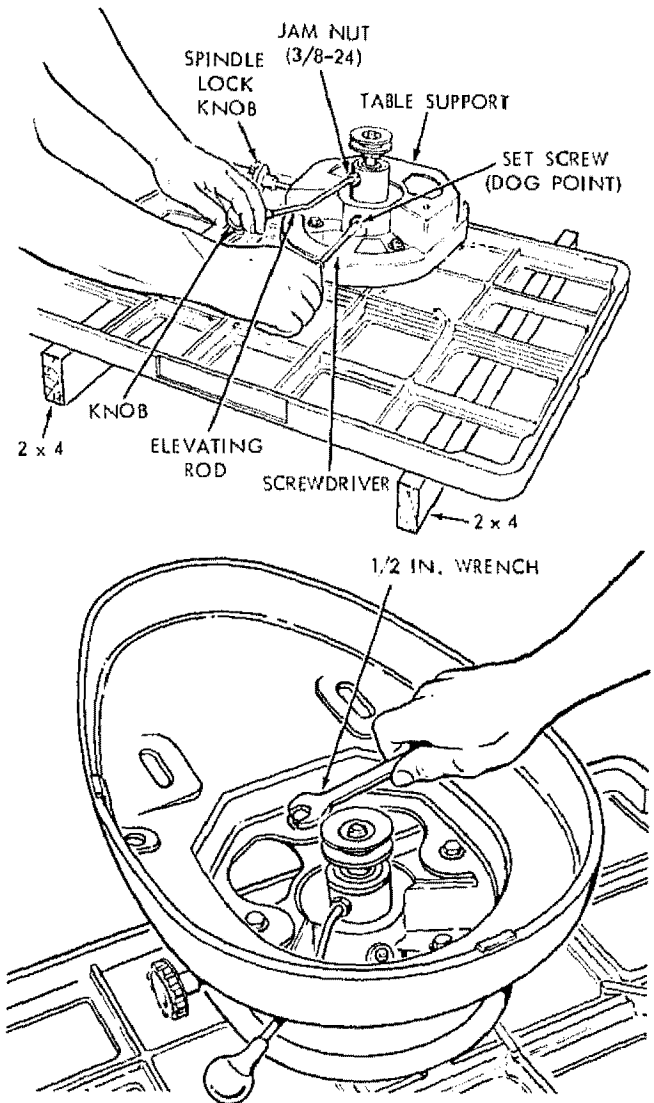

MOUNTING BELT GUARD AND MOTOR TO MOTOR MOUNT

1. Place the motor mount on your workbench.
2. Support rear of motor mount with 3/4" stock as shown.
3. Find four 5/16" x 18 x 1-1/4 carriage bolts, four 5/16-18 hex nuts, and two 21/64 x 3/4 x 1/16 Flat Washers. Position hardware as shown.

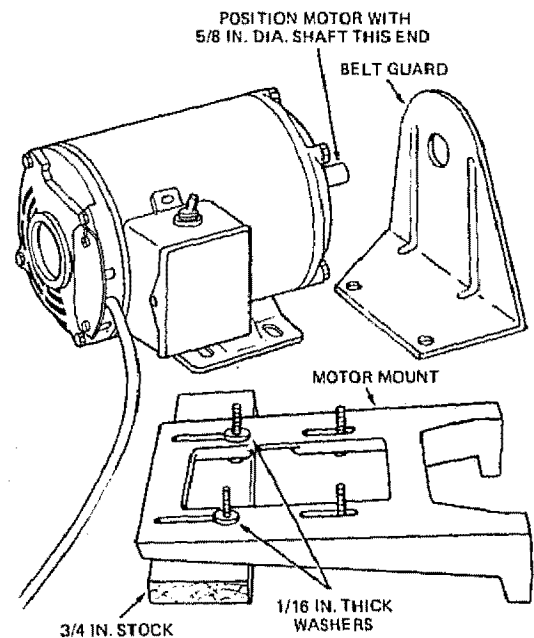

4. Place Belt Guard under Motor (between Motor Support Bracket and Motor Mount) and make certain 5/8" shaft is centered in Belt Guard hole. Install nuts finger tight.

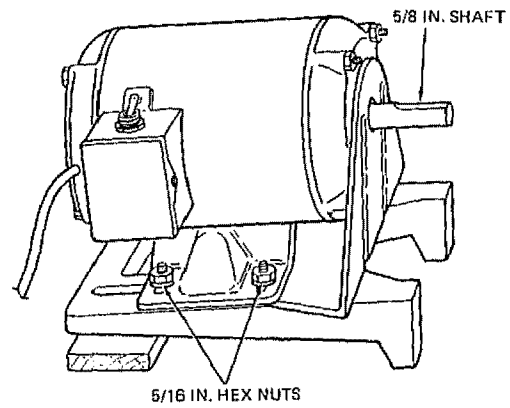

INSTALLING MOTOR PULLEY

1. Install motor pulley (flat-faced pulley) on motor shaft, with closed end of pulley facing out. Tighten pulley set screw securely.

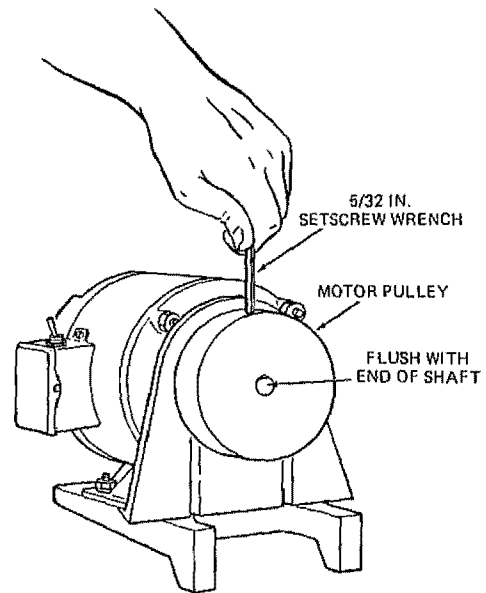

2. Using table insert as a spacer, position motor on motor mount plate to provide a distance of 1/4-inch from mounting edge of motor mount plate as shown. Tighten the four motor mount bolts securely and recheck for correct positioning.

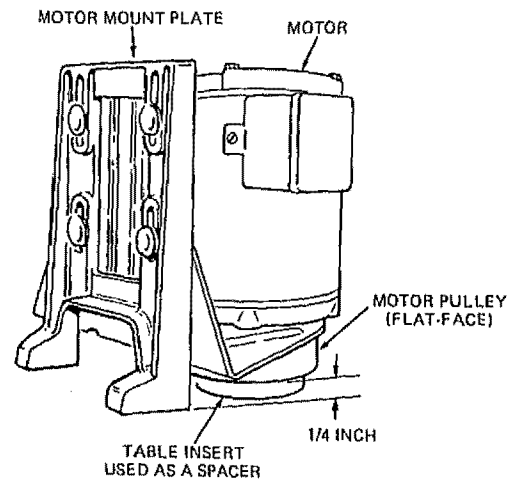

MOUNTING MOTOR SUPPORT ASSEMBLY TO SHAPER

1. Place V-belt on motor pulley and attach motor mount plate to shaper base with two bolts (3/8-16 x 1-inch) and washers. Leave bolts finger tight.
2. Roll the belt onto spindle pulley, pull motor mount plate toward end of base until belt is tight enough to prevent slipping and tighten the two bolts. Each bolt should be in approximately the same position in the base slots.
3. Position elevating rod in approximate mid position and turn spindle pulley by hand several times to see that the belt rides in the approximate mid position of motor pulley. If not, recheck assembly. The belt should change positions on motor pulley as the lever position is changed (while the spindle pulley is rotated by hand).

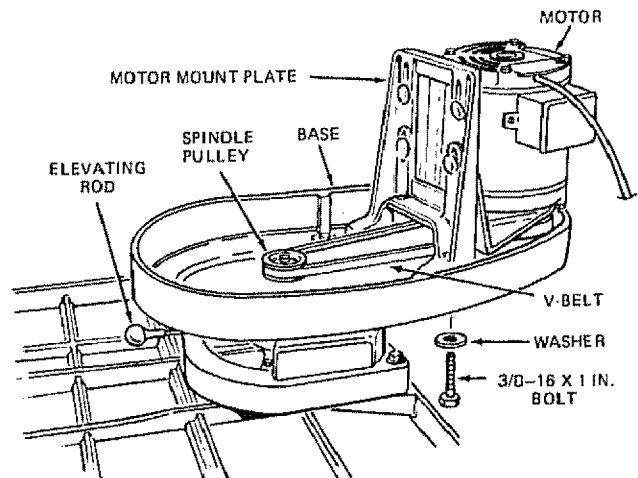

MOUNTING SWITCH ASSEMBLY

1. Attach the switch assembly to the underside of the Shaper table using the two screws and lockwashers packed with the switch.

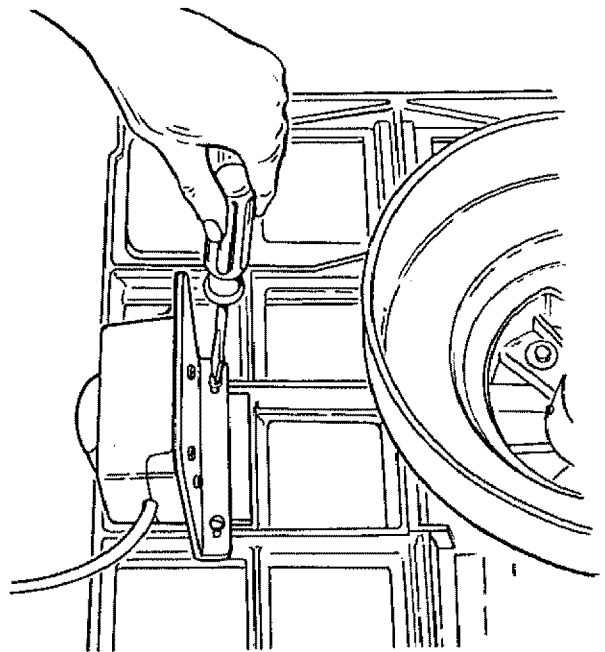

ASSEMBLING STEEL LEGS

1. Assemble the two (2) End Stiffeners and the two (2) Side Stiffeners using four (4) 1/4-20 Truss head screws. The End Stiffeners are placed on top of each Side Stiffener as shown. Insert screws through the 9/32 inch diameter holes and finger tighten 1/4-20 nuts.
2. Attach the four (4) legs to the side and End Stiffener using 1/4-20 screws, lockwashers and nuts as shown.
3. Remove the four (4) Truss head screws which were assembled in Paragraph No. One. Place the two (2) Support Channels as shown, in position, align holes in supports with holes in the side Stiffeners, replace lockwashers and nuts. Tighten all nuts using 7/16" wrench.
4. The two (2) Stiffeners, (F) are fastened to the top side of each side stiffener using N8 x 1/2 self-threading screws. The guard plate is mounted as shown using same screws.
5. Install leveling feet as shown. To level Leg Set, loosen nut on inside of leg and turn nut on outside to raise or lower feet. Adjust all four levelers, if necessary, and then tighten nuts on inside of leg.

NOTE: These levelers are not intended for height adjustment.

Item	Part Name	Qty.
A	Leg	4
B	* Screw, Truss Hd. 1/4-20 x 5/8	28
C	* Nut, Hex 1/4-20	28
D	* Lockwasher, 1/4 External	28
E	Channel, Support	2
F	Stiffener	2
G	Stiffener, Side	2
H	Stiffener, End	2
J	* Screw, Pan Hd. Ty A N8 x 1/2	4
K	* Nut, Hex Hd. 3/8-16	8
L	* Foot, Leveling	4

* These parts contained in Loose Part bag #508411.

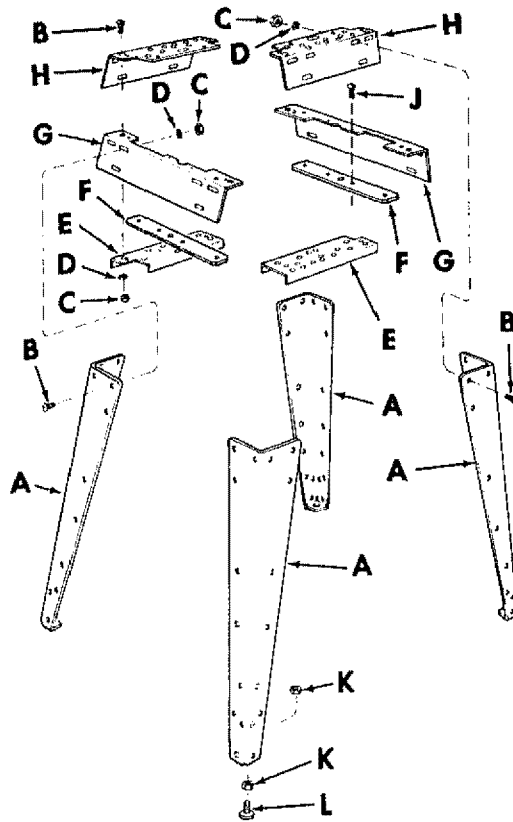

MOUNTING WOOD SHAPER ON FLOOR STAND

1. Three mounting holes are provided in the base of the shaper for the purpose of mounting it securely on a substantial tool stand with screws or bolts.
2. The tool stand should be high enough so the top surface of the shaper table will be 35 to 37 inches above the floor. The shaper must be mounted to allow the motor to overhang rear edge of tool stand.

CAUTION: The shaper must be mounted on a substantial tool stand and secured so there is no possibility of tipping. The Shaper must be positioned on the tool stand so that the spindle pulley is guarded from the bottom.

Place the Shaper on the Steel LEGS. Position as shown, and align mounting holes. Secure with 3 ea. 5/16" x 18 x 3" screws; washers and nuts.

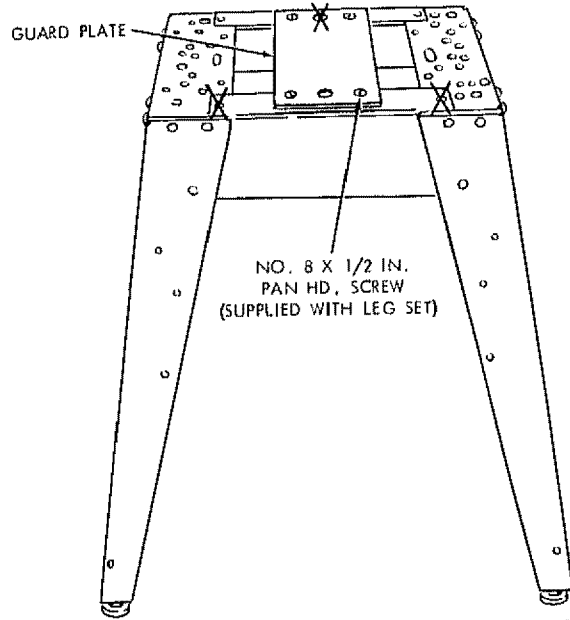

PLUGGING IN MOTOR

1. Find plastic cable hanger from among the loose parts.
2. Route the motor cord behind the motor mount, across the top of the Leg Set and plug it into the receptacle in the side of the switch box.
3. Bring the power cord alongside the motor cord... wrap the plastic cable hanger around the cords and attach the hanger to the top of the Leg Set.

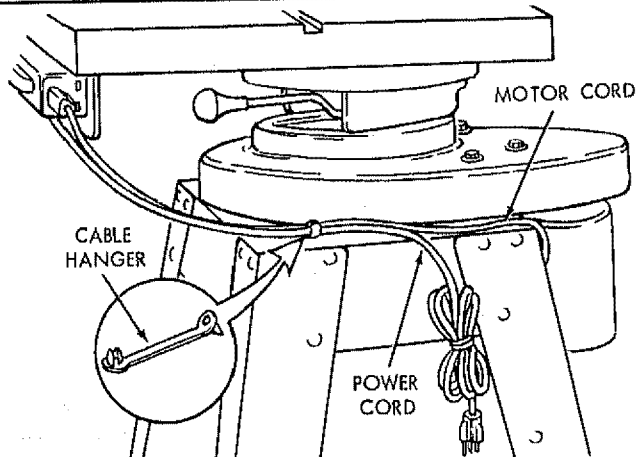

INSTALLING SHAPER FENCE — FOR STRAIGHT EDGE SHAPING ONLY

1. Install the fence with two 5/16-18 x 2 inch hex head screws and two plain washers. These screws thread into tapped holes in the table. Adjust the fence as outlined on page 13.

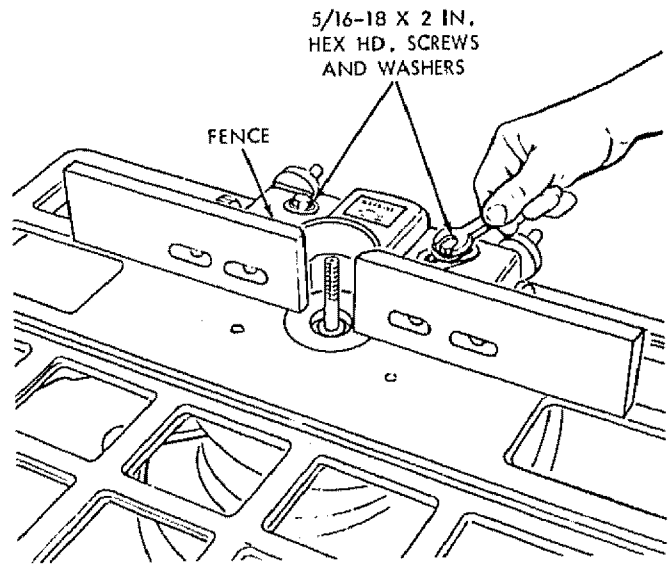

INSTALLING SHAPER CUTTER GUARD — FOR CURVED OR IRREGULAR SHAPING ONLY

NOTE: Fence must be removed.

1. Assemble Cutter Guard as illustrated.

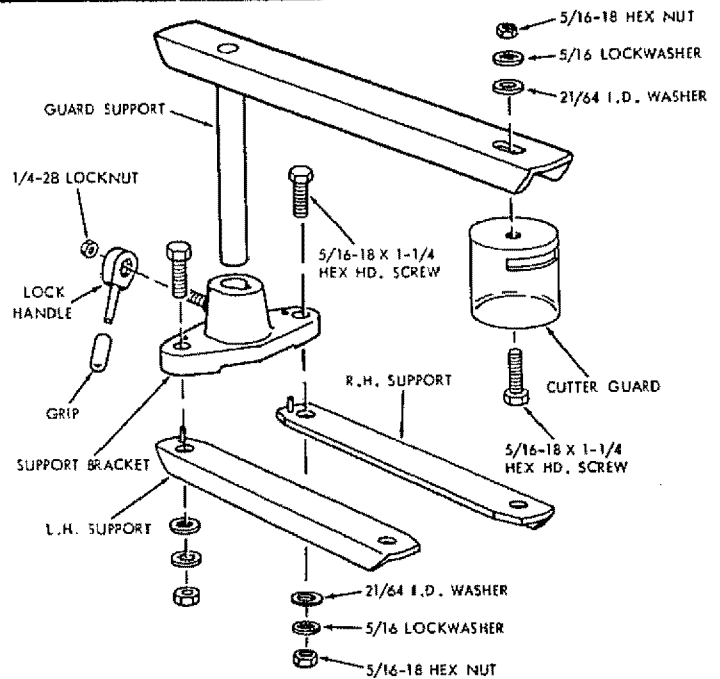

Align the guard support so that it is centered on the shaper spindle (It may be necessary to loosen the 5/16-18 screws which secure the support bracket to the channels to perform this adjustment). After the alignment is achieved tighten all four screws securely.

Install Cutter Guard Assembly to table support using the two 5/16-18 x 2 inch hex head screws located at rear of table support.

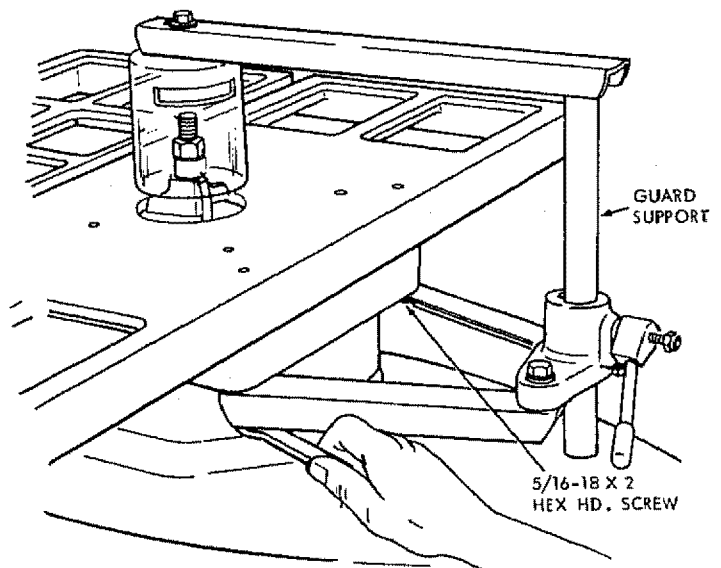

GETTING TO KNOW YOUR WOOD SHAPER

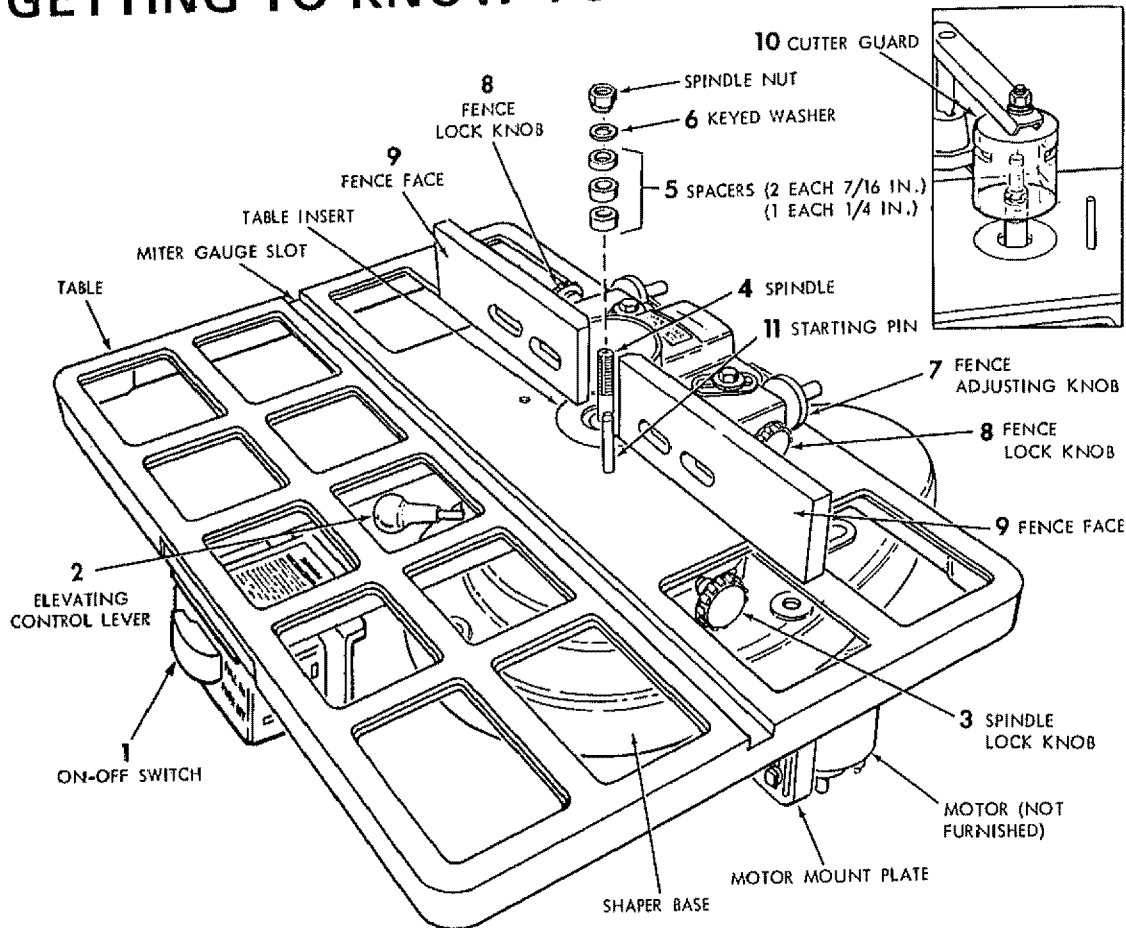

MOTOR ROTATION

The motor equipped with the shaper is designed to be operated in a clockwise or counterclockwise rotation by use of a select switch located on the motor. Before the motor is turned on, move the select switch "up" for clockwise rotation or "down" for counterclockwise rotation. The direction of rotation cannot be changed while the motor is running. Turn the motor off and wait until the motor has stopped completely before selecting the desired rotation.

WARNING: Once the motor rotation has been selected always check to be sure the spindle is rotating in the correct direction for the cutter being used.

1. ON-OFF SWITCH

CAUTION: Before turning switch on, make sure the cutter is installed properly and the keyed washer is positioned below the spindle nut.

The On-Off Switch has a locking feature. THIS FEATURE IS INTENDED TO PREVENT UNAUTHORIZED AND POSSIBLE HAZARDOUS USE BY CHILDREN AND OTHERS.

- a. TO turn Shaper ON . . . insert finger under switch lever and pull END of lever out.

After turning switch ON, always allow the cutter to come up to full speed before cutting.

Do not cycle the motor switch on and off rapidly, as this may cause the cutter to loosen. In the event this should ever occur, allow the cutter to come to a complete stop and retighten the spindle nut normally, not excessively. Never leave the shaper while the power is "ON".

- b. TO turn shaper OFF . . . PUSH lever in. Never leave the shaper until the cutting tool has come to a complete stop.

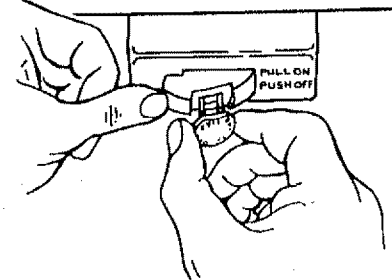
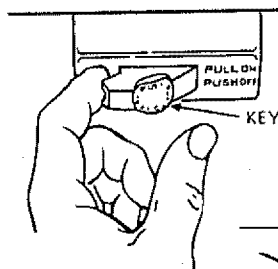
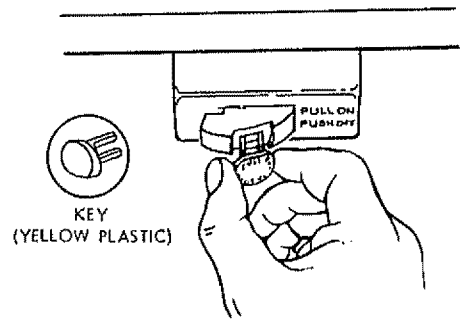

- c. TO lock switch in OFF position . . . hold switch IN with one hand . . . REMOVE key with other hand.
ALWAYS LOCK THE SWITCH "OFF" WHEN SHAPER IS NOT IN USE . . . REMOVE KEY AND KEEP IT IN A SAFE PLACE . . . ALSO . . . IN THE EVENT OF A POWER FAILURE (ALL OF YOUR LIGHTS GO OUT) TURN SWITCH OFF . . . LOCK IT AND REMOVE THE KEY. THIS WILL PREVENT THE SHAPER FROM STARTING UP AGAIN WHEN THE POWER COMES BACK ON.

2. ELEVATING CONTROL LEVER

The Elevating Control Lever moves the spindle vertically a distance of 7/8-inch to locate the cutter at the desired vertical position.

- 3. SPINDLE LOCK KNOB** — used to lock the spindle and quill assembly after the desired height has been determined.

CAUTION: Always release the quill lock knob before attempting to change the position of spindle and tighten the knob securely before starting operation.

- 4. SPINDLE** — This shaper is designed for use with maximum 2-1/2-inch diameter cutters having a 1/2-inch diameter bore.

- 5. SPACERS** — A total of three spacers are provided, two 7/16 inch thick and one 1/4 inch thick for positioning the cutter for desired shapes.

- 6. KEYED WASHER** — Must always be positioned immediately below the spindle nut.

- 7. FENCE ADJUSTING KNOB** — Each fence face may be moved forward or backward by turning the fence adjusting knobs.

- 8. FENCE LOCK KNOB** — After the desired fence face position has been selected, the fence is secured by tightening the fence lock knobs.

- 9. FENCE FACES** — Each fence may be moved forward or backward by releasing the fence lock knob and turning the fence adjusting knobs. Each fence face operates independently of the other, by means of the adjusting mechanism. After the desired fence position has been selected, it is secured by tightening the fence lock knob. The fence faces will close in from a maximum three-inch opening down to one-inch for small diameter cutters, by loosening the two screws in the front of each face and sliding the face to the desired position. The screws must be tightened securely after each setting.

CAUTION: The opening between inner ends of fence faces should never be larger than required to just clear the particular cutter being used. **ALWAYS ROTATE THE SPINDLE BY HAND BEFORE STARTING THE SHAPER MOTOR TO MAKE SURE CUTTER DOES NOT STRIKE FENCE FACES.**

10. CUTTER GUARD

NOTE: Used for curved or irregular shaping only — fence must be removed and starting pin must be in place on in-feed side.

Provides added protection for irregular shaping. Guard is adjustable for various thickness of material.

CAUTION: Always rotate the spindle by hand before starting the shaper motor to make sure cutter does not strike guard.

11. STARTING PIN

The Starting Pin must be used as a pivot to support the work until it has been fed into the cutter and against the collar. The Starting Pin may be located in either of the two threaded holes near the table insert opening, depending upon the direction of rotation, but **ALWAYS** on the in-feed side.

12. REMOVING AND INSTALLING CUTTERS

- Raise spindle to maximum height
- To REMOVE cutter, hold spindle with the 1/4" hex wrench and loosen nut with wrench provided as shown — Reverse procedure to TIGHTEN SPINDLE NUT.

NOTE: TO AVOID POSSIBLE BENDING OF THE SPINDLE LOOSEN OR TIGHTEN NUT WITH BOTH WRENCHES POINTING AS NEARLY IN THE SAME DIRECTION AS POSSIBLE.

CAUTION: Always have the keyed washer directly under the nut, otherwise the nut may loosen and serious injury could result.

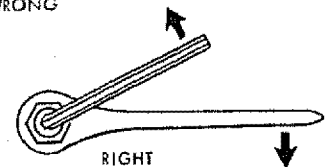
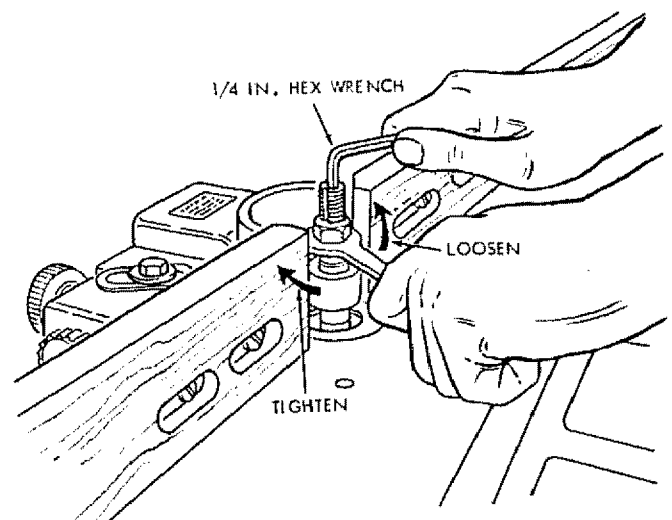

ADJUSTMENTS

WARNING: For your own safety, turn switch "off" and remove plug from power source outlet before making any adjustments.

ADJUSTABLE SHAPER FENCE

1. Move both fence faces out $3/4"$ by turning the two fence adjusting knobs.

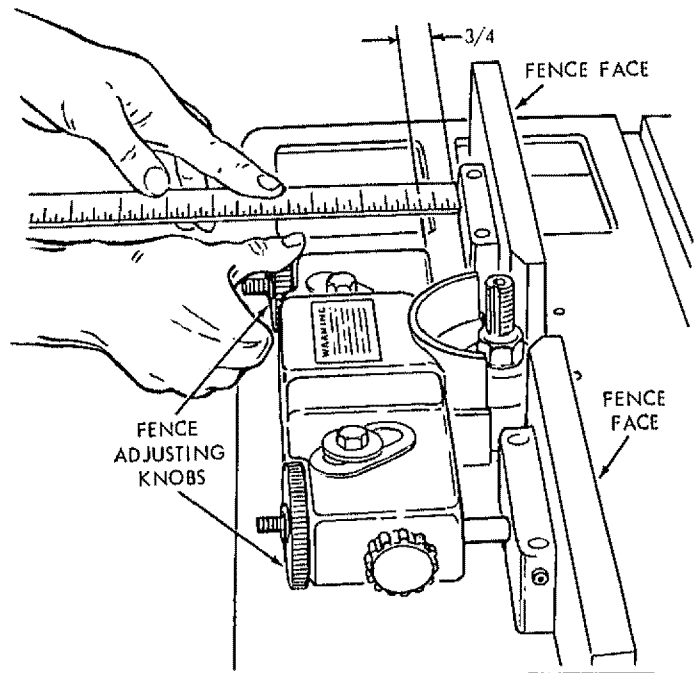

2. Position fence faces in the same plane by using a framing square or straightedge and adjusting the fence adjusting knob.
3. Loosen the fence attaching bolts and shift the complete fence assembly until both fence faces are the same distance from the miter slot.

Tighten fence attaching bolts after fence has been correctly positioned.

Check this adjustment after tightening bolts to make sure it did not change.

Lock all controls securely after desired settings have been completed.

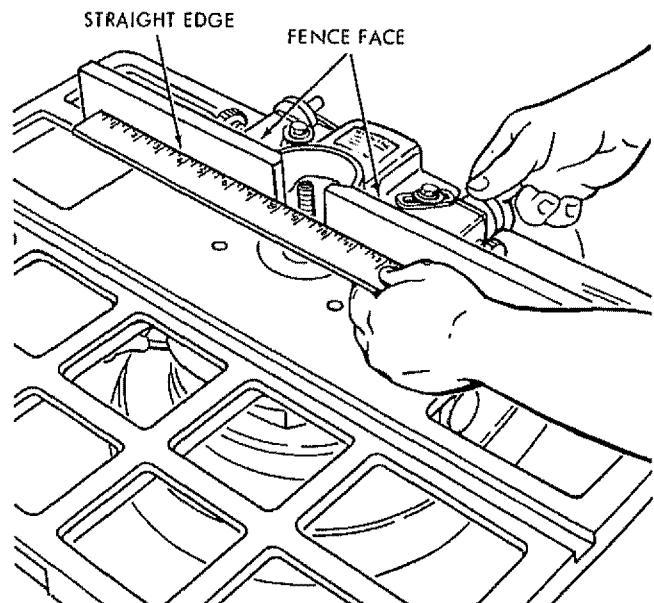

FENCE FACES

1. Loosen the four (4) screws as shown and slide each fence face in as close to the cutter as possible, but do not permit the cutter to strike fence faces.
2. Set the fence faces so the cutter (Not supplied see Recommended Accessory List) projects far enough beyond them to produce the desired depth of cut. If the cutter is set to remove only a portion of the edge of the work piece, the two fence faces should be set even with each other.

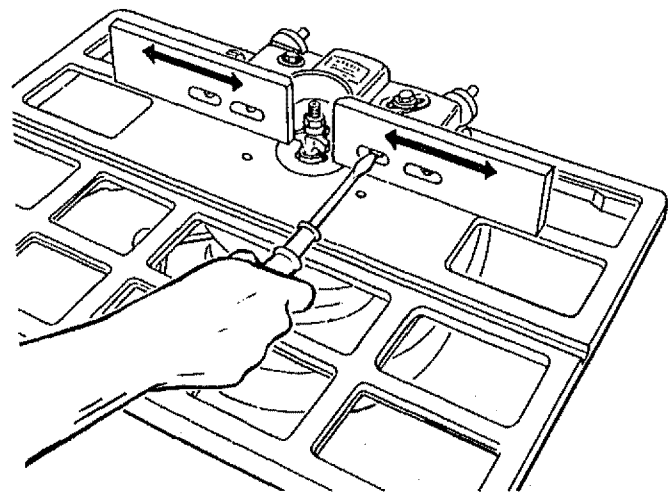

BASIC SHAPING OPERATIONS

NOTE: This shaper is designed for use with maximum 2-1/2 inch diameter cutters having a 1/2 inch diameter bore.

1. For those operators who prefer to use a motor that rotates clockwise (facing pulley end) which would drive the spindle in a clockwise direction the motor select switch should be in the up position. With this combination, the work would be fed into the cutter from the left-hand side of the table. In most cases, the cutter would have to be turned over.
2. For those operators which may require counterclockwise rotation of the spindle, the motor select switch should be in the down position and with this combination the work should be fed into the cutter from the right side of the shaper.
3. Always remember, when mounting the cutter, the cutting edge of the cutter must lead into the direction of rotation and the work piece must be fed against the direction of the cutter.

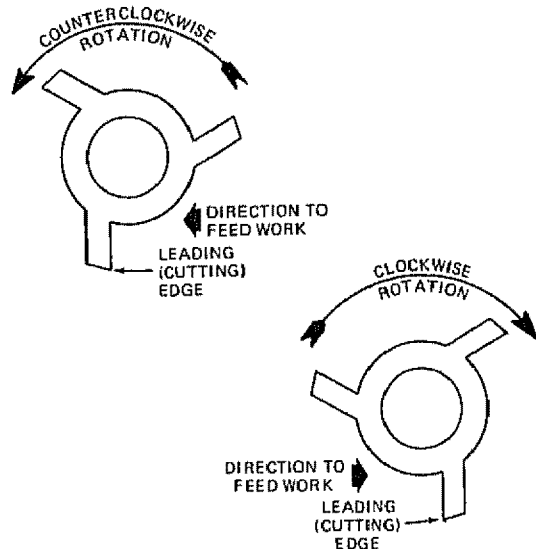

USE OF CUTTER SPACERS

1. The spacers can be positioned below and above the cutter.
Notice when the spacer is positioned below the cutter how the spacer provides a bearing surface for the uncut edge of the board, in addition to its use as a spacer in vertical positioning of the cutter.

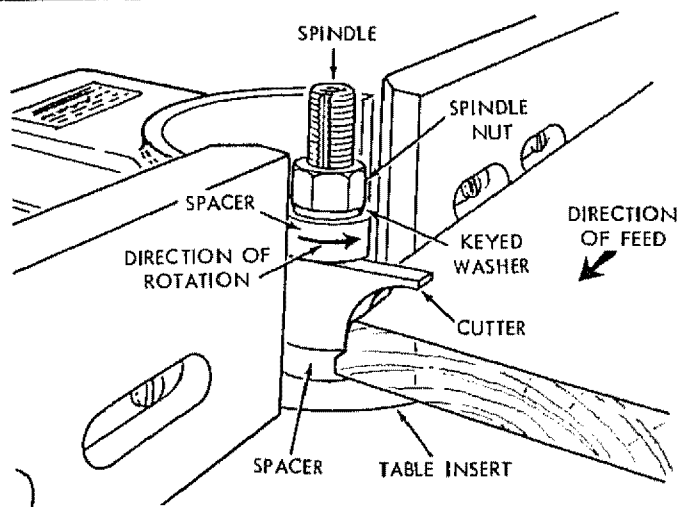

2. This same cutter can be inverted and mounted to produce a shape with the board fed through in the opposite direction IF DIRECTION OF ROTATION OF THE SPINDLE IS REVERSED.

Notice how the spacer again provides a bearing surface for the uncut edge of the board.

3. Cut the workpiece to size, so the shaping cut will be as light as possible to produce the desired pattern.

CAUTION: Do not attempt to use the Shaper for sizing a workpiece (except when using the jointer cutter and adjustable fence).

4. Feed workpiece against rotation of cutter.

NOTE: It is a very good practice to make a trial cut on a piece of scrap wood as a double check on the set-up before using the actual workpiece.

WARNING: Serious injury may result if workpiece is not always fed into the cutter against the direction of rotation of the cutter. Experience will suggest the proper direction for producing the desired shape.

5. If the cut removes the workpiece, reduce the width of the fence in front of the workpiece enough to provide support for the workpiece after the cut.

thus
-feed
| face
after
perly

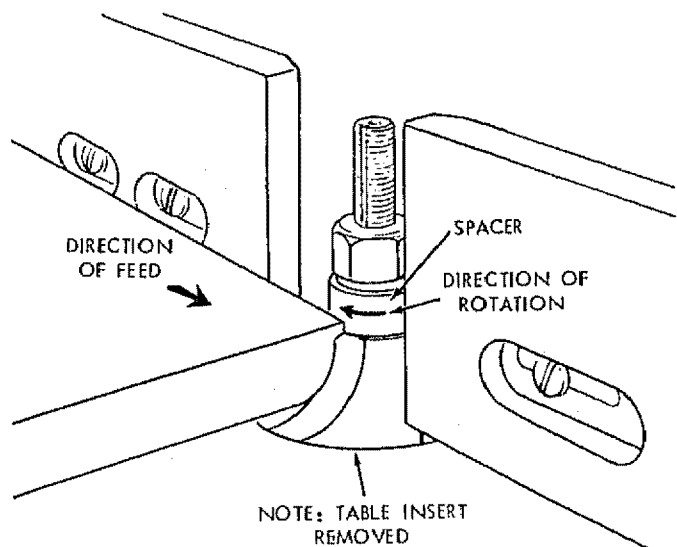

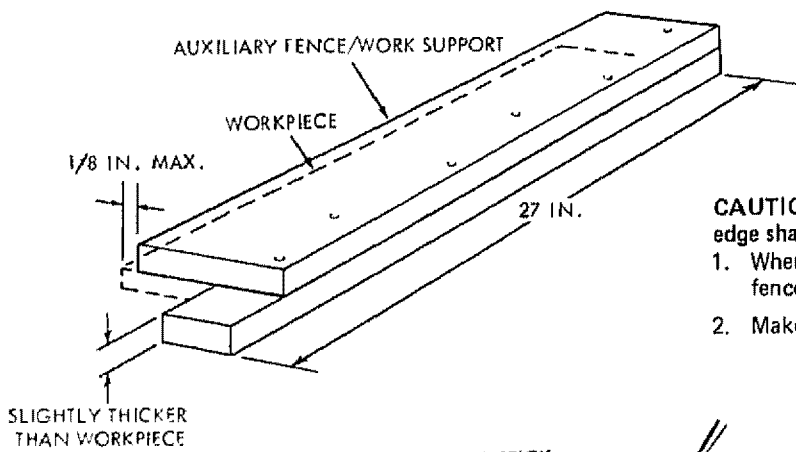

STRAIGHT EDGE SHAPING

CAUTION: The Shaper fence must be used in all straight edge shaping operations.

1. When shaping stock 3 inches wide or less, an auxiliary fence/work support must be used as shown.
2. Make the push stick as shown.

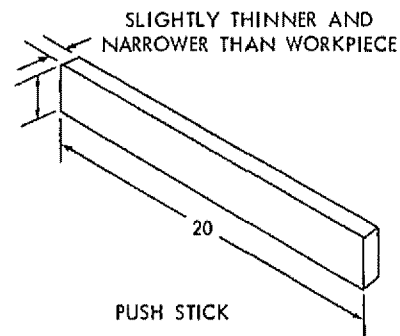
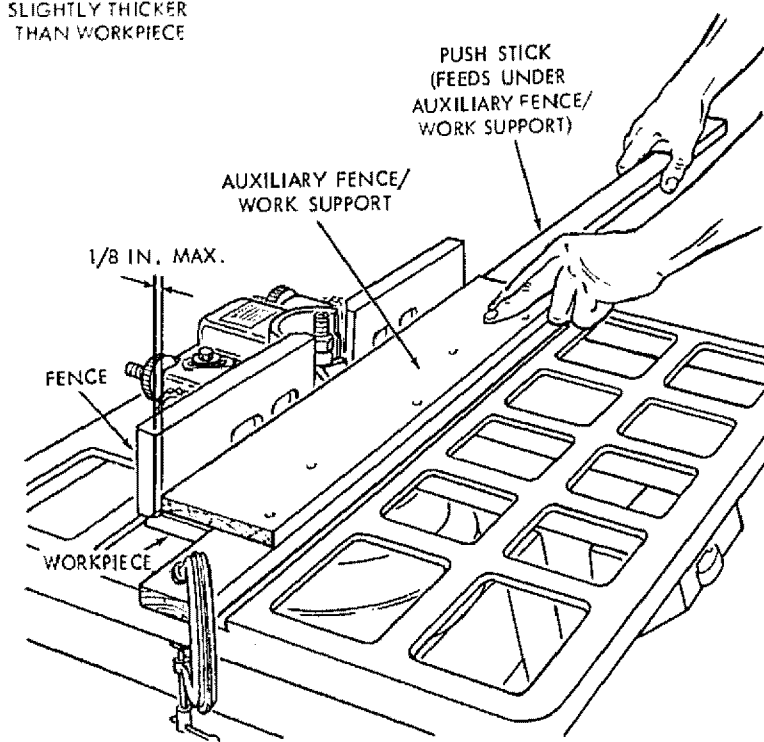

END SHAPING WITH USE OF MITER GAUGE AND HOLD-DOWN CLAMP (OPTIONAL ACCESSORIES)

1. NEVER use the Miter Gauge on the Shaper without the Hold-down Clamp installed and the workpiece clamped.
2. Both fence faces MUST be positioned so the workpiece cannot contact them.
3. Adjust the head of the miter gauge so the end of the workpiece to be shaped will be exactly parallel to the miter gauge slot in the table. This holds true for all angles of the end of the workpiece.
4. The board is positioned in the miter gauge; then hold the workpiece firmly against the miter gauge head and down on the table with your left hand, and feed by gripping the lock handle with your right hand.

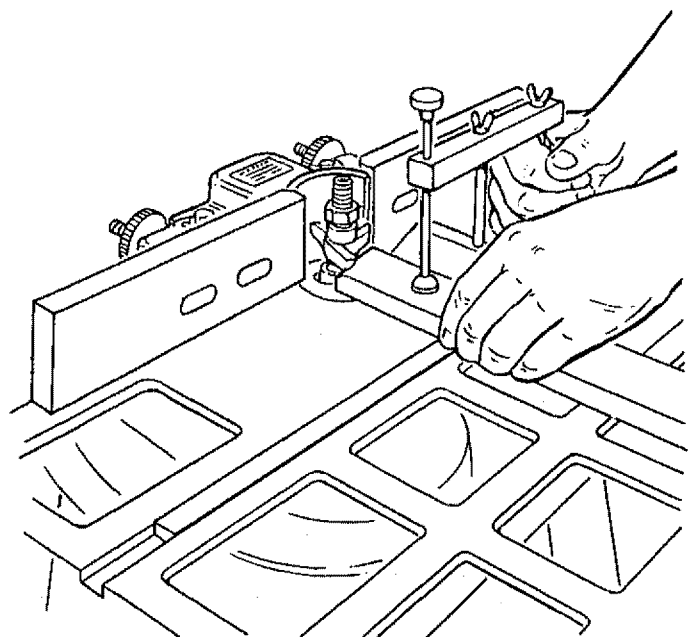

IRREGULAR OR CURVED SHAPING

A variety of shapes may be produced with the shaper by changing the the height of cutter in relation to the workpiece, by using various combinations of cutters on successive passes, and/or by inverting cutter and changing direction of spindle rotation and feed direction. The table insert must be removed if the cutter does not clear the hole in the insert when the cutter is lowered below the table surface: check clearance before turning switch "ON":

1. To make irregular shaping cuts remove power cable from electrical source, remove the fence assembly, select the shaper collar that will position the cutter to obtain the desired pattern, and lock the shaper collar and cutter on the spindle.

NOTE: A shaper collar may be located above or below a cutter, or between the two cutters selected.

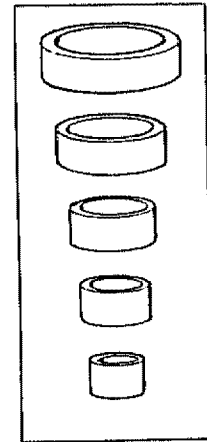
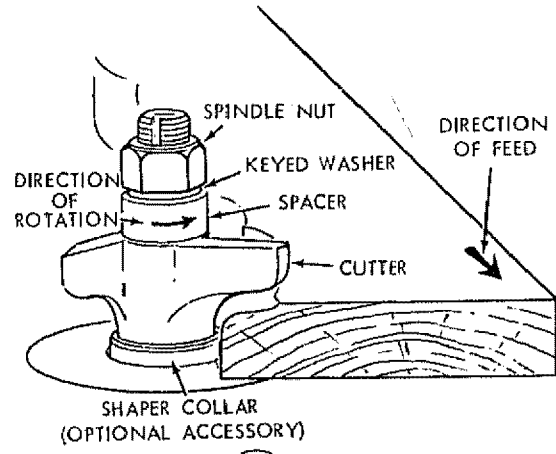

SHAPER COLLAR SET
(OPTIONAL ACCESSORY)

2. Mount the cutter guard and adjust as shown.
Position the Guard vertically (A) (Guard should just clear workpiece)
Center the Guard over the cutter. (B)
NOTE: Rotate cutter by hand and check for proper clearance inside guard.

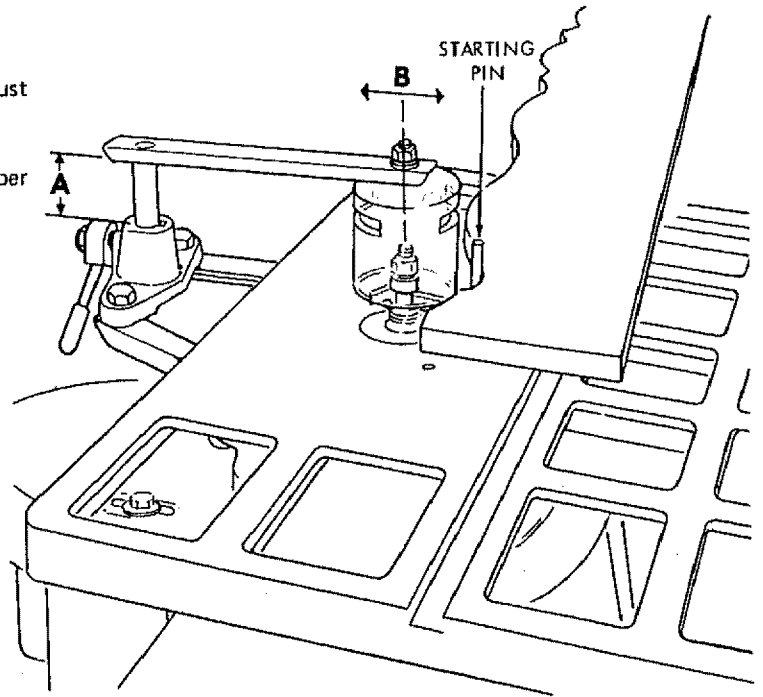

3. The starting pin must be used as a pivot to support the work until it has been fed into the shaper collar. The Starting Pin may be located in either of the two threaded holes near the table insert opening, depending upon the direction of rotation, but **always on the in-feed side.**
4. Start the workpiece by pivoting it around the starting pin slowly into the path of the cutter until the workpiece contacts the shaper collar.

WARNING: Do not attempt to shape warped lumber.

Workpiece **MUST** contact the **FRONT** of the cutter and collar - toward the miter gauge slot.

5. In addition, the following operations are some which can be performed on the shaper - shaping with a pattern, tongue and groove joints, rearing and fluting, etc. ("Power Tool Know How" Handbooks are available) See Recommended Accessories list.

NOTE: After a few hours of operation, tighten both pulley set screws securely with the Hex wrenches provided.

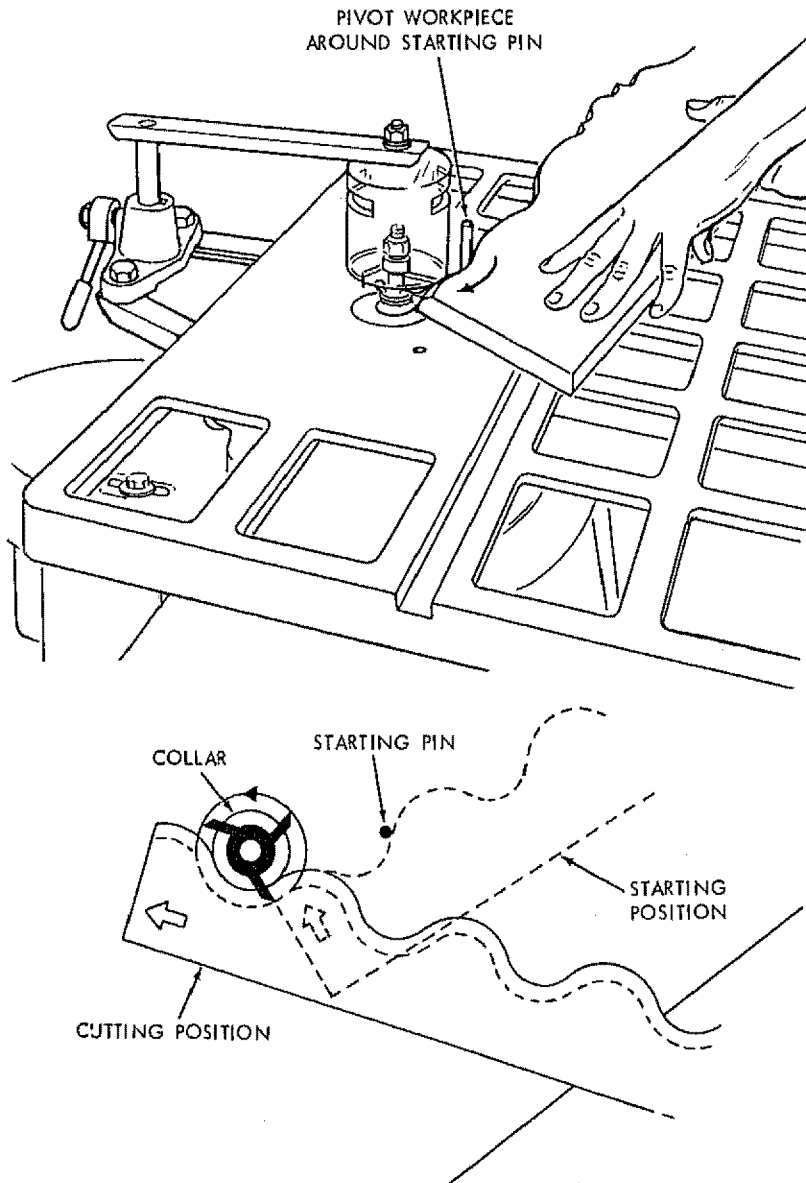

MAINTENANCE

WARNING: For your own safety, turn switch "OFF" and remove plug from power source outlet before maintaining or lubricating your saw.

NOTE: After a few hours of operation, tighten both pulley set screws securely with the Hex wrenches provided.

Frequently clean your cutting tools with Craftsman Gum and Pitch Remover.

A coat of automobile -type wax applied to the table will help to keep the surface clean and allow workpieces to slide more freely.

If the power cord is worn or cut, or damaged in any way, have it replaced immediately.

LUBRICATION

The ball bearings used on the cutter spindle have been packed with lubricant at the factory and require no further attention.

To maintain smooth and easy operation, occasionally add a few drops of oil to the outside of the spindle assembly.

MOTOR MAINTENANCE AND LUBRICATION

1. The sleeve bearings, in both end shields of the motor, have been lubricated at the factory with correct lubricant. No other part of the motor requires lubrication.
2. Re-lubricate motor bearings in accordance with the instructions on the nameplate. Be sure to wipe off dirt or grit if present around oil hole caps to prevent any possibility of foreign material contaminating the oil wicks that supply the bearings with oil. Use a good grade of medium weight mineral oil, such as automobile engine oil, SAE 20.
3. If disassembly of the motor is necessary, it should be returned to your nearest Sears retail or mail-order store in order to prevent voiding the guarantee.

NOTE: The speed of this motor cannot be regulated or changed.

4. Every effort should be made to prevent foreign material from entering the motor. When operated under conditions likely to permit accumulations of dust, dirt or waste within the motor, a visual inspection should be made at frequent intervals. Accumulations of dry dust can usually be blown out successfully.

NOTE: Motors used on wood-working tools are particularly susceptible to the accumulation of sawdust and wood chips and should be blown out or "vacuumed" frequently to prevent interference with normal ventilation and proper operation of the centrifugally-operated starting switch.

SEARS RECOMMENDS THE FOLLOWING ACCESSORIES

ITEM	CAT. NO.
Casters	9-22222,9-22221
Shaper Collar Set	See Catalog
Shaper Cutters	See Catalog
Push Blocks	9-2299
Miter Gauge	9-29929
Miter Gauge Hold Down	9-29928
"Power Tool Know How" handbook	9-29117
Universal Jig	9-3231

Sears may recommend other Accessories not listed in manual.

See your nearest Sears Store or Catalog Department for other Accessories.

Do not use any Accessory unless you have received and read complete instructions for its use.

TROUBLE SHOOTING

WARNING: For your own safety, turn switch "off" and remove plug from power source outlet before trouble shooting your shaper.

TROUBLE	PROBABLE CAUSE	REMEDY
Spindle Assembly actuates too hard.	Set screw engaging slot in spindle assembly too tight.	Tighten screw then back it off 1/4 turn. Adjust until action is smooth without end play.
Cutter comes loose during operation.	Keyed washer not properly installed.	The keyed washer must always be used directly under the nut.
Cutter slow down during operation.	<ol style="list-style-type: none"> 1. Work being fed too rapidly. 2. Insufficient belt tension. 3. Glazed belt 	<ol style="list-style-type: none"> 1. Feed work through more slowly to allow cutter to remove stock smoothly. 2. Loosen motor mount plate bolts and move motor slightly toward rear of shaper until belt tension is correct, tighten bolts. 3. Replace belt.
Binding of Fence Boards when adjusting in or out.	Bottoms of fence faces striking table.	Loosen the two screws through front of face, raise it slightly and tighten screws.
Shaper produces ragged or ripple cuts.	<ol style="list-style-type: none"> 1. Work piece not being held firmly against fence and/or table. 2. Interrupted feed past cutter. 3. Dull cutter. 4. Belt slipping -- causing cutter speed to vary. 5. Cutter blades not concentric. (Blade segments have uneven lengths.) 6. Work being fed too rapidly. 7. Quality of wood not sufficient to produce desired results. 	<ol style="list-style-type: none"> 1. Apply sufficient hand pressure in both directions or revise Auxiliary Fence/Work Support (pg. 15) accordingly. 2. Maintain continuous feed. 3. Sharpen or replace cutter 4. Adjust belt for proper tension. 5. Replace or resharpen cutter. 6. Feed work through slow enough to produce smooth cut. 7. Use a better grade of material.
Shaper produces a smooth cut, but does not hold a straight edge.	<ol style="list-style-type: none"> 1. Fence faces improperly set. 2. Spindle Assembly lock knob not tight. 3. Workpiece not held snugly against fence. 4. Work piece not held snugly against table. 5. Work being fed to rapidly. 6. Attempting to remove more material than required to produce desired shape. 7. Fence loose on table. 	<ol style="list-style-type: none"> 1. Adjust fence faces. 2. Tighten spindle assembly lock knob. 3. Increase hand pressure or revise Auxiliary Fence/Work Support (pg. 15). 4. Increase hand pressure or revise Auxiliary Fence/Work Support (pg. 15). 5. Feed work through more slowly. 6. Joint workpiece to proper width before shaping edge. 7. Tighten fence.
Shape varies across width of board.	<ol style="list-style-type: none"> 1. Work not held securely to miter gauge and/or to table. 2. End of workpiece not parallel with miter gauge slot. 3. End to be shaped is wavy (not straight). 	<ol style="list-style-type: none"> 1. Hold work firmly against miter gauge and down on the table. 2. Adjust miter gauge. 3. Resaw and/or joint as necessary.

TROUBLE SHOOTING -- MOTOR

NOTE: Motors used on wood-working tools are particularly susceptible to the accumulation of sawdust and wood chips and should be blown out or "vacuumed" frequently to prevent interference with normal motor ventilation.

TROUBLE	PROBABLE CAUSE	REMEDY
Excessive noise.	1. Motor.	1. Have motor checked by qualified service technician. Repair service is available at your nearest Sears store.
Motor fails to develop full power. NOTE: LOW VOLTAGE: (Power output of motor decreases rapidly with decrease in voltage at motor terminals. For example, a reduction of 10% in voltage causes a reduction of 19% in maximum power output of which the motor is capable, and a reduction of 20% in voltage causes a reduction of 36% in maximum power output.)	1. Circuit overloaded with lights, appliances and other motors. 2. Undersize wires or circuit too long. 3. General overloading of power company facilities.	1. Do not use other appliances or motors on same circuit when using the saw. 2. Increase wire sizes, or reduce length of wiring. See "Motor Specifications and Electrical Requirements" section. 3. Request a voltage check from the power company.
Motor starts slowly or fails to come up to full speed.	1. Low voltage. 2. Windings burned out or open. 3. Starting switch not operating.	1. Request voltage check from the power company. Check size of circuit wiring. 2. Have motor repaired or replaced. 3. Have switch replaced.
Motor overheats.	1. Motor overloaded. 2. Improper cooling. (Air circulation restricted through motor due to sawdust, accumulating inside of saw).	1. Feed work slower into blade. 2. Clean out sawdust to provide normal air circulation through motor. See "Maintenance and Lubrication" section.
Starting switch in motor will not operate.	1. Burned switch contacts (due to extended hold-in periods caused by low line voltage, etc.) 2. Shorted capacitor 3. Loose or broken connections.	1. Have switch replaced and request a voltage check from the power company. 2. Have capacitor tested and replace if defective. 3. Have wiring checked and repaired.
Motor stalls (resulting in blown fuses or tripped circuit breakers).	1. Starting switch not operating. 2. Voltage too low to permit motor to reach operating speed. 3. Fuses or circuit breakers do not have sufficient capacity.	1. Have switch replaced. 2. Request voltage check from the power company. 3. Install proper size fuses or circuit breakers.
Frequent opening of fuses or circuit breakers.	1. Motor overloaded. 2. Fuses or circuit breakers do not have sufficient capacity. 3. Starting switch not operating (motor does not reach speed).	1. Feed work slower into blade. 2. Install proper size fuses or circuit breakers. 3. Have switch replaced.

REPAIR PARTS

PARTS LIST FOR CRAFTSMAN WOOD SHAPER
MODEL NO. 113.239392, 113.239400 AND 113.239420

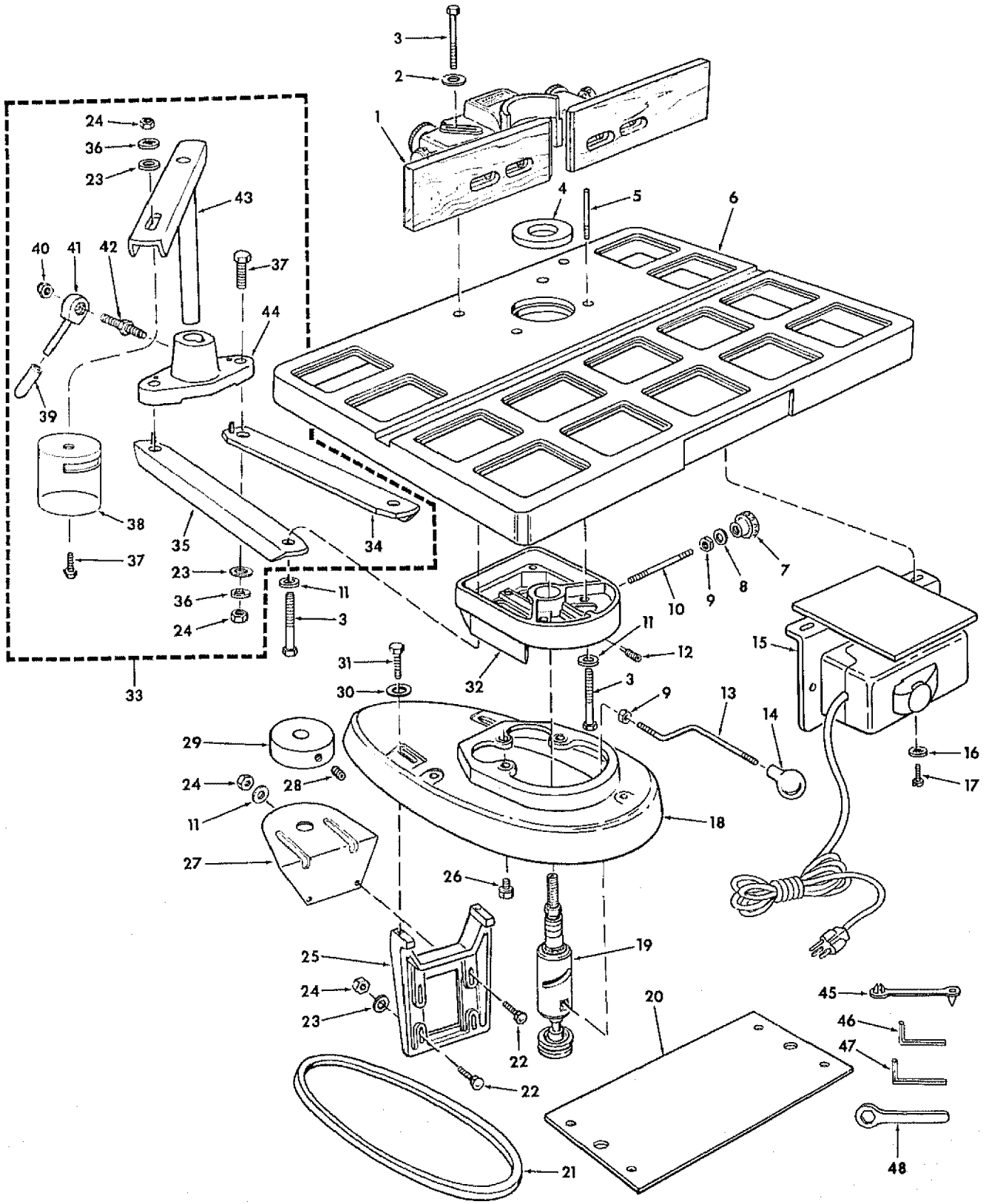

**PARTS LIST FOR CRAFTSMAN WOOD SHAPER
MODEL NO. 113.239392, 113.239400 AND 113.239420**

Always Order by Part No. - Not by Key Number

FIGURE 1

Key No.	Part No.	Description
1	72008	Fence Assembly (See Figure 2)
2	60167	Washer, .343 x 1.062 x 1/8
3	STD 523120	*Screw, Hex Hd. 5/16-18 x 2
4	39411	Insert, Table
5	39613	Pin, Table Dowel
6	C39290	Table (Includes Nameplate)
7	39512	Knob, Lock
8	STD 551037	*Washer, 13/32 x 47/64 x 1/16
9	STD 541137	*Nut, Hex. Jam, 3/8-24
10	39629	Stud, Lock
11	STD551031	*Washer, 21/64 x 7/8 x 1/8
12	38799	Screw, Set, 3/8-24 x 3/4 Dog Pt.
13	39628	Rod, Elevating
14	38546	Knob
15	60382	Switch Box Assembly (See Figure 4)
16	STD 551210	*Lockwasher, Internal No. 10
17	STD 511105	*Screw, Pan Hd. 10-32 x 1/2
18	39215	Base
19	-----	Spindle Assembly (See Figure 5)
20	72014	Plate, Guard
21	STD 304330	*Belt, V, 1/2 x 33
22	STD 533112	*Bolt, Carriage 5/16-18 x 1-1/4
23	STD 551031	*Washer 21/64
24	STD 541231	*Nut, Hex 5/16-18
25	39217	Mount, Motor
26	453068	Screw, Mach., 5/16-18 x 3/4, Hex. Hd. w/Lockwasher

Key No.	Part No.	Description
27	72003	Guard, Pulley
28	STD 503102	*Screw, Set 5/16-18 x 5/16, Soc. Hd. Cup Pt.
29	39230	Pulley, Motor, (w/Set Screw)
30	STD 551037	*Washer, 25/64 x 1-9/64 x 7/64
31	STD 523710	*Screw, Hex Hd. 3/8-16 x 1
32	39216	Support Table
33	72027	Guard, Asm. Cutter
34	72024	Support Assembly, R.H.
35	72025	Support Assembly, L.H.
36	STD 551231	*Lockwasher, Internal 5/16
37	STD 523112	Screw, Hex Hd. 5/16 x 18 x 1-1/4
38	72005	Guard, Cutter
39	60262	Grip
40	STD 541525	*Nut, Lock 1/4-28
41	70001	Hub Asm. Lock (Includes Key No. 39)
42	56634	Stud, Nut
43	72026	Arm, Guard
44	72023	Holder, Guard
45	68036	Hanger, Cable
46	37435	*Wrench, Hex., 1/4
47	37837	*Wrench, Hex., 5/32
48	38713	Wrench
-	508181	Bag of Loose Parts (Not Illus)
-	508415	Bag of Loose Parts (Not Illus)
-	SP5427	Owners Manual (Not Illus)

*Standard Hardware Items — May be Purchased Locally.

**PARTS LIST FOR CRAFTSMAN WOOD SHAPER
MODEL NO. 113.239392, 113.239400 AND 113.239420**

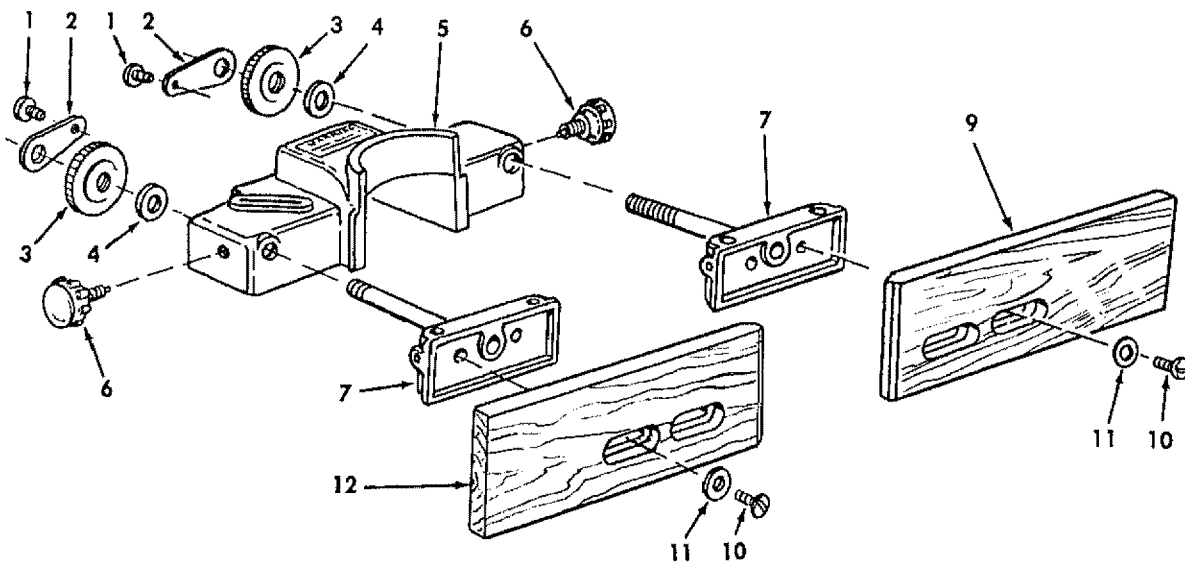

FIGURE 2 – FENCE ASSEMBLY 72008

Key No.	Part No.	Description
—	72008	Fence Assembly Complete
1	STD 511005	*Screw, Pan Hd., 10-24 x 1/2
2	38711	Bracket, Retaining
3	38612	Knob, Adjusting
4	18451	Washer, Spring
5	38413	Frame
6	38531	Knob
7	38110	Shoe Assy., Fence
9	38533	Plate, Work Face (Right)
10	STD 512507	*Screw, Pan Hd., 1/4-20 x 3/4
11	STD 551012	*Washer, Plain, 1/4
12	38532	Plate, Work Face (Left)

*Standard Hardware Item — May be Purchased Locally.

**PARTS LIST FOR CRAFTSMAN WOOD SHAPER
MODEL NO. 113.239392, 113.239400 AND 113.239420**

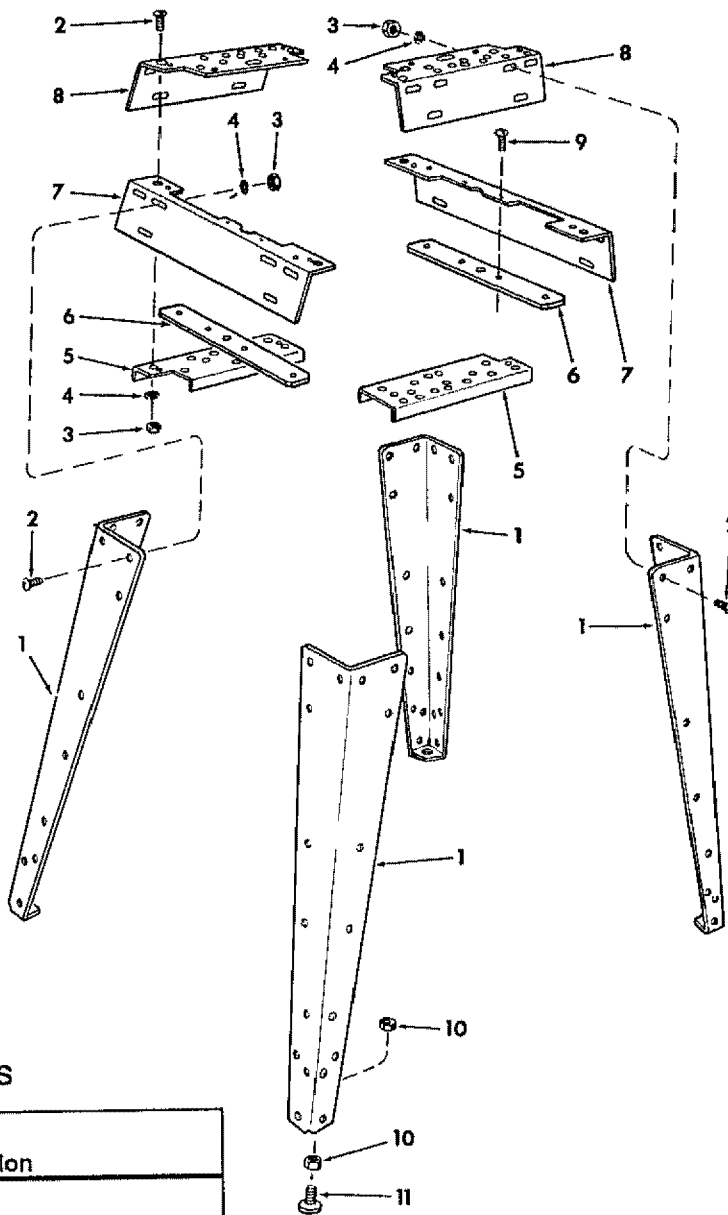

FIGURE 3 - LEGS

Key No.	Part No.	Description
1	820040	Leg
2	60314	* Screw, Truss Hd. 1/4-20 x 5/8
3	STD541025	*† Nut, Hex 1/4-20
4	STD551225	*† Lockwasher, 1/4 External
5	68060	Channel, Support
6	72030	Stiffener
7	68059	Stiffener, Side
8	62615	Stiffener, End
9	STD610805	*† Screw, Pan Hd. Ty. A N8 x 1/2
10	STD541237	*† Nut, Hex Hd. 3/8-16
11	803835-1	† Foot, Leveling
-	508411	Bag of Loose Parts (Not illus)
HARDWARE FOR MOUNTING TOOL		
-	STD523130	† Screw, Hex Hd. 5/16-18 x 3
-	STD 551131	*† Lockwasher, 5/16 External
-	STD541231	*† Nut, Hex Jam 5/16-18
-	STD551031	* Washer, 11/32 ID

* Standard Hardware Item - May be purchased locally.

† These parts contained in Loose Parts Bag #508411.

**PARTS LIST FOR CRAFTSMAN WOOD SHAPER
MODEL NO. 113.239392, 113.239400 AND 113.239420**

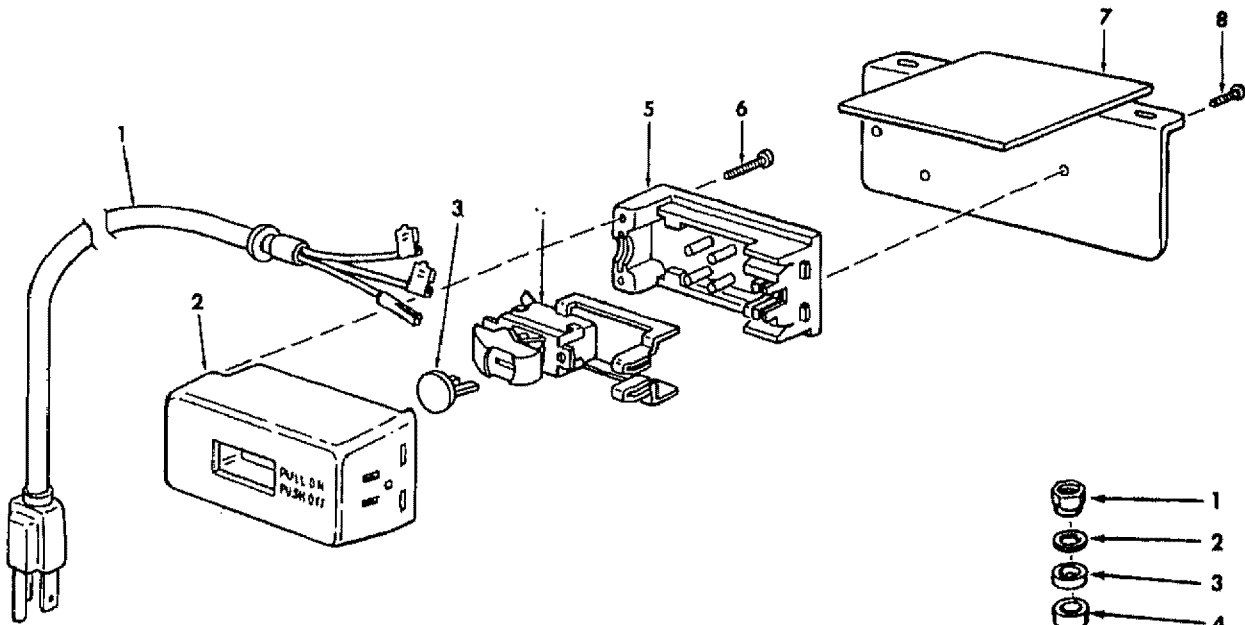

**FIGURE 4 –
ON/OFF POWER OUTLET 60382
AND MOUNTING BRACKET**

Key No.	Part No.	Description
—	60382	• On/Off Power Outlet
1	508984	Cord, Molded
2	822206	Housing, Switch
3	60256	Key, Switch
4	60374	Switch, Locking
5	822205	Cover, Switch
6	448007	Screw, Pan Hd. No. 6 x 3/4
7	72034	Bracket, Switch Mounting
8	STD600803	*Screw, Pan Hd. Plastite No. 8 x 3/8

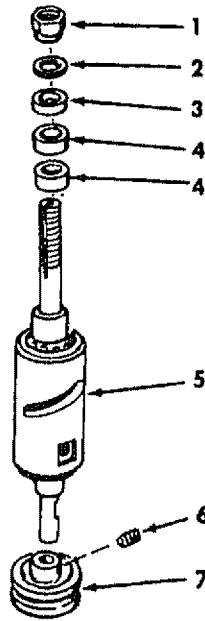

FIGURE 5 – SPINDLE ASSEMBLY

Key No.	Part No.	Description
—	-----	Spindle Assembly Complete
1	39615	Nut, Spindle
2	39711	Washer, Keyed
3	39616	Spacer 1/4
4	39617	Spacer 7/16
5	507727	Spindle Assembly
6	STD 603103	*Screw, Set 5/16-18 x 3/8, Soc. Hd. Cup pt.
7	STD 328011	*Pulley, (w/Set Screw) "V" 2 x 1/2 Bore

*Standard Hardware Item – May be Purchased Locally.

• Does Not Include Key No. 3
Order Separately If Required.

*Standard Hardware Item – May be Purchased Locally.

**PARTS LIST FOR CRAFTSMAN WOOD SHAPER
MODEL NO. 113.239392, 113.239400 AND 113.239420**

FIGURE 6 - MOTOR PARTS LIST

ANY ATTEMPT TO REPAIR THIS MOTOR MAY CREATE A HAZARD UNLESS REPAIR IS DONE BY QUALIFIED SERVICE TECHNICIAN.

REPAIR SERVICE IS AVAILABLE AT YOUR NEAREST SEARS STORE

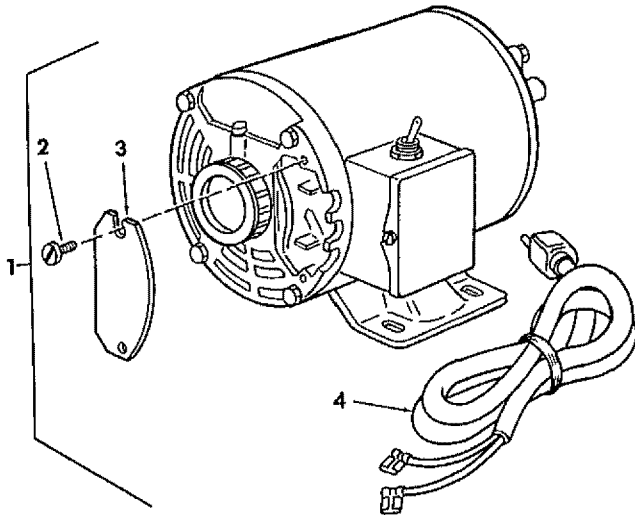

Key No.	Part No.	Description
1	9-12008 820041 820152	†Motor, 1/2 H.P. (Complete) Motor, 3/4 H.P. (Complete) Motor, 1 H.P. (Complete)
2	60306	Screw, 8-32 x 3/8, Thread Cutting, Slotted, Serrated Hd.
3	64088	Cover, Terminal
4	64258	Cord with Plug

†Stock Item may be secured through the Hardware Department of Most Sears Retail or Catalog Order Houses.

MOTOR CONNECTIONS

WARNING: FOR YOUR OWN SAFETY, NEVER CONNECT PLUG TO POWER SOURCE OUTLET UNTIL ALL ASSEMBLY STEPS ARE COMPLETED.

1. Open motor connector box cover located on left end of motor (viewed from rear of saw) using a flat blade screwdriver.
2. Remove GREEN SCREW and lockwasher and insert screw through round metal terminal on the end of the GREEN wire of power cord with lockwasher between terminal and motor frame. (See illus.)
3. Reinsert GREEN SCREW in the threaded hole. Tighten securely.
4. Insert terminal end of WHITE wire on spade terminal marked T4 on the motor. Push terminal firmly until seated.
5. Insert terminal end of BLACK wire on spade terminal marked T1 on the motor. Push terminal firmly until seated.
6. Close motor connector box being sure that power cord is seated in the largest strain relief groove, and tighten box cover screws.

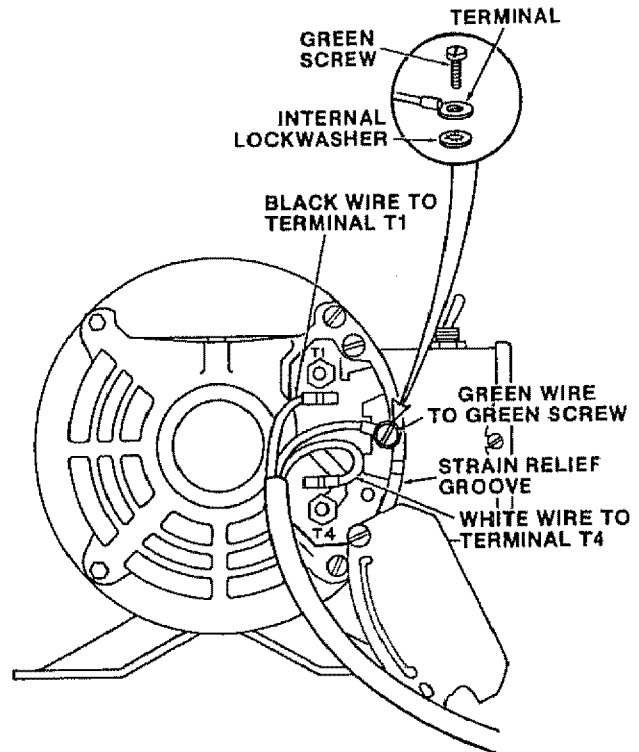

SEARS

owners manual

SERVICE

MODEL NO.

113.239392

**SHAPER WITH STEEL
LEGS AND 1/2 H.P.
MOTOR**

113.239400

**SHAPER WITH STEEL
LEGS AND 3/4 H.P.
MOTOR**

113.239420

**SHAPER WITH STEEL
LEGS AND 1 H.P. MOTOR**

HOW TO ORDER REPAIR PARTS

IF YOU NEED REPAIR SERVICE OR PARTS:

For Repair Service, Call this
Toll Free Number:
1-800-4-REPAIR
(1-800-473-7247)

For replacement parts informa-
tion and ordering, call this toll
free number:

1-800-FON-PART
(1-800-366-7278)

WOOD SHAPER

Now that you have purchased your wood shaper, should a need ever exist for repair parts or service, simply contact any Sears Service Center and most Sears, Roebuck and Co. stores. Be sure to provide all pertinent facts when you call or visit.

The model number of your wood shaper will be found on a plate attached to your wood shaper on the front of the table.

**WHEN ORDERING REPAIR PARTS, ALWAYS GIVE
THE FOLLOWING INFORMATION:**

PART NUMBER	PART DESCRIPTION
--------------------	-------------------------

MODEL NUMBER	NAME OF ITEM
113.239392	Wood Shaper
113.239400	
113.239420	

All parts listed may be ordered from any Sears Service Center and most Sears stores. If the parts you need are not stocked locally, your order will be electronically transmitted to a Sears Repair Parts Distribution Center for handling.

Sears, Roebuck and Co., Hoffman Estates, IL. 60179 U.S.A.