

# PRO·FORM<sup>®</sup> 725 TL

## PERFORMANCE TREADMILL

# SEARS

Model No. 831.297763

Serial No. \_\_\_\_\_

The serial number is found in the location shown below. Write the serial number in the space above for future reference.

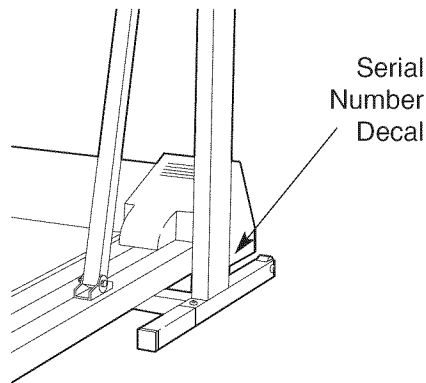

EXERCISE  
EQUIPMENT

QUESTIONS

HELPLINE!

1-800-736-6879

### ⚠ CAUTION

Read all precautions and instructions in this manual before using this equipment. Save this manual for future reference.



## USER'S MANUAL

SEARS, ROEBUCK AND CO., HOFFMAN ESTATES, IL 60179

---

# TABLE OF CONTENTS

FULL 90 DAY WARRANTY .....	2
IMPORTANT PRECAUTIONS .....	3
BEFORE YOU BEGIN .....	5
ASSEMBLY .....	6
HOW TO USE THE PULSE SENSOR .....	8
OPERATION AND ADJUSTMENT .....	9
HOW TO USE THE MANUAL MODE .....	11
HOW TO USE THE WEIGHT LOSS PROGRAMS AND THE INTERVAL PROGRAMS .....	13
HOW TO USE THE FAT BURN AND AEROBIC PROGRAM .....	15
HOW TO USE THE FITNESS TEST PROGRAM .....	16
HOW TO FOLD AND MOVE THE TREADMILL .....	18
TROUBLE-SHOOTING .....	20
CONDITIONING GUIDELINES .....	22
ORDERING REPLACEMENT PARTS .....	Back Cover

Note: An EXPLODED DRAWING and a PART LIST are attached to the center of this manual. Please save them for future reference.

## **FULL 90 DAY WARRANTY**

For 90 days from the date of purchase, if failure occurs due to defect in material or workmanship in this SEARS TREADMILL EXERCISER, contact the nearest SEARS Service Center throughout the United States and SEARS will repair or replace the TREADMILL EXERCISER, free of charge.

This warranty does not apply when the TREADMILL EXERCISER is used commercially or for rental purposes.

This warranty gives you specific legal rights, and you may also have other rights which vary from state to state.

**SEARS, ROEBUCK AND CO., DEPT. 817WA, HOFFMAN ESTATES, IL 60179**

# IMPORTANT PRECAUTIONS

**⚠ WARNING:** To reduce the risk of burns, fire, electric shock, or injury to persons, read the following important precautions and information before operating the treadmill.

1. It is the responsibility of the owner to ensure that all users of this treadmill are adequately informed of all warnings and precautions.
2. Use the treadmill only as described in this manual.
3. Place the treadmill on a level surface, with 8 feet of clearance behind it. Do not place the treadmill on any surface that blocks air openings. To protect the floor or carpet from damage, place a mat under the treadmill.
4. Keep the treadmill indoors, away from moisture and dust. Do not put the treadmill in a garage or covered patio, or near water.
5. Do not operate the treadmill where aerosol products are used or where oxygen is being administered.
6. Keep children and pets away from the treadmill at all times.
7. The treadmill should be used only by persons weighing 250 pounds or less.
8. Never allow more than one person on the treadmill at a time.
9. Wear appropriate exercise clothing when using the treadmill. Do not wear loose clothing that could become caught in the treadmill. Athletic support clothes are recommended for both men and women. *Always wear athletic shoes. Never use the treadmill with bare feet, wearing only stockings, or in sandals.*
10. When connecting the power cord (see HOW TO PLUG IN THE POWER CORD on page 9), plug the power cord into a surge protector (not included) and plug the surge protector into a grounded circuit capable of carrying 15 or more amps. No other appliance should be on the same circuit.
11. Use only a UL-listed surge protector, rated at 15 amps, with a 14-gauge cord of five feet or less in length. Do not use an extension cord.
12. Keep the power cord and the surge protector away from heated surfaces.
13. Never move the walking belt while the power is turned off. Do not operate the treadmill if the power cord or plug is damaged, or if the treadmill is not working properly. (See BEFORE YOU BEGIN on page 5 if the treadmill is not working properly.)
14. Never start the treadmill while you are standing on the walking belt. Always hold the handrails while using the treadmill.
15. The treadmill is capable of high speeds. Adjust the speed in small increments to avoid sudden jumps in speed.
16. To reduce the possibility of the treadmill overheating, do not operate the treadmill continuously for longer than one hour.
17. The pulse sensor is not a medical device. Various factors, including the user's movement, may affect the accuracy of heart rate readings. The pulse sensor is intended only as an exercise aid in determining heart rate trends in general.
18. Never leave the treadmill unattended while it is running. Always remove the key and move the on/off switch to the "off" position when the treadmill is not in use. (See the drawing on page 5 for the location of the on/off switch.)
19. Do not attempt to raise, lower, or move the treadmill until it is properly assembled. (See ASSEMBLY on page 6, and HOW TO MOVE THE TREADMILL on page 19.) You must be able to safely lift 45 pounds (20 kg) to raise, lower, or move the treadmill.
20. When folding or moving the treadmill, make sure that the storage latch is fully closed.
21. During the last ten seconds of a preset program, the treadmill will automatically adjust to the lowest incline level. Keep your feet and objects from beneath the treadmill.

- 22. Inspect and tighten all parts of the treadmill every three months.
- 23. Never insert any object into any opening.
- 24. Always unplug the power cord before performing the maintenance and adjustment procedures described in this manual. Never remove the motor hood unless instructed to

do so by an authorized service representative. Servicing other than the procedures in this manual should be performed by an authorized service representative only.

- 25. This treadmill is intended for in-home use only. Do not use this treadmill in any commercial, rental, or institutional setting.

**⚠ WARNING:** Before beginning this or any exercise program, consult your physician. This is especially important for persons over the age of 35 or persons with pre-existing health problems. Read all instructions before using. SEARS assumes no responsibility for personal injury or property damage sustained by or through the use of this product.

## SAVE THESE INSTRUCTIONS

**⚠ WARNING!**

- Never allow children to play on or around treadmill.
- Storage latch must be fully engaged before treadmill is moved or stored.

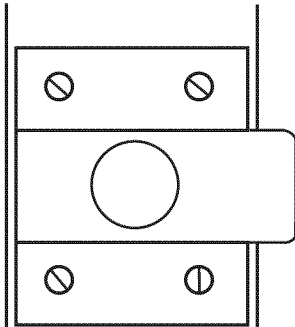

The decals shown have been placed on your treadmill. If a decal is missing, or if it is not legible, please call our toll-free HELPLINE to order a free replacement decal (see the back cover of this manual). Apply the decals in the location shown.

**IMPORTANT:** *Incline must be at lowest level before folding treadmill into storage position.*

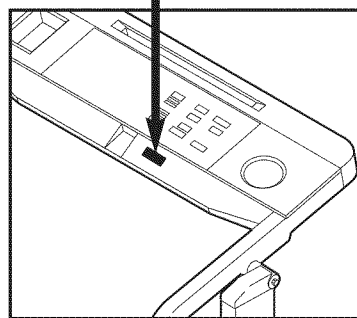
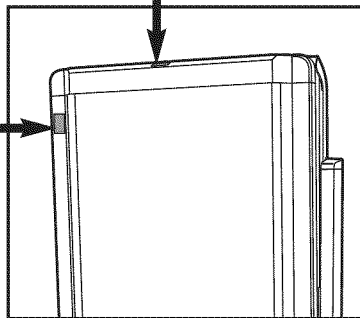

# BEFORE YOU BEGIN

Thank you for selecting the PROFORM® 725 TL treadmill. The 725 TL treadmill blends advanced technology with innovative design to let you enjoy an excellent form of cardiovascular exercise in the convenience and privacy of your home.

**For your benefit, read this manual carefully before using the treadmill.** If you have additional questions, please call our toll-free HELPLINE at **1-800-736-6879**, Monday through Saturday, 7 a.m. until 7 p.m. Central

Time (excluding holidays). To help us assist you, please note the product model number and serial number before calling. The model number of the treadmill is 831.297763. The serial number can be found on a decal attached to the treadmill (see the front cover of this manual for the location).

Before reading further, please review the drawing below and familiarize yourself with the parts that are labeled.

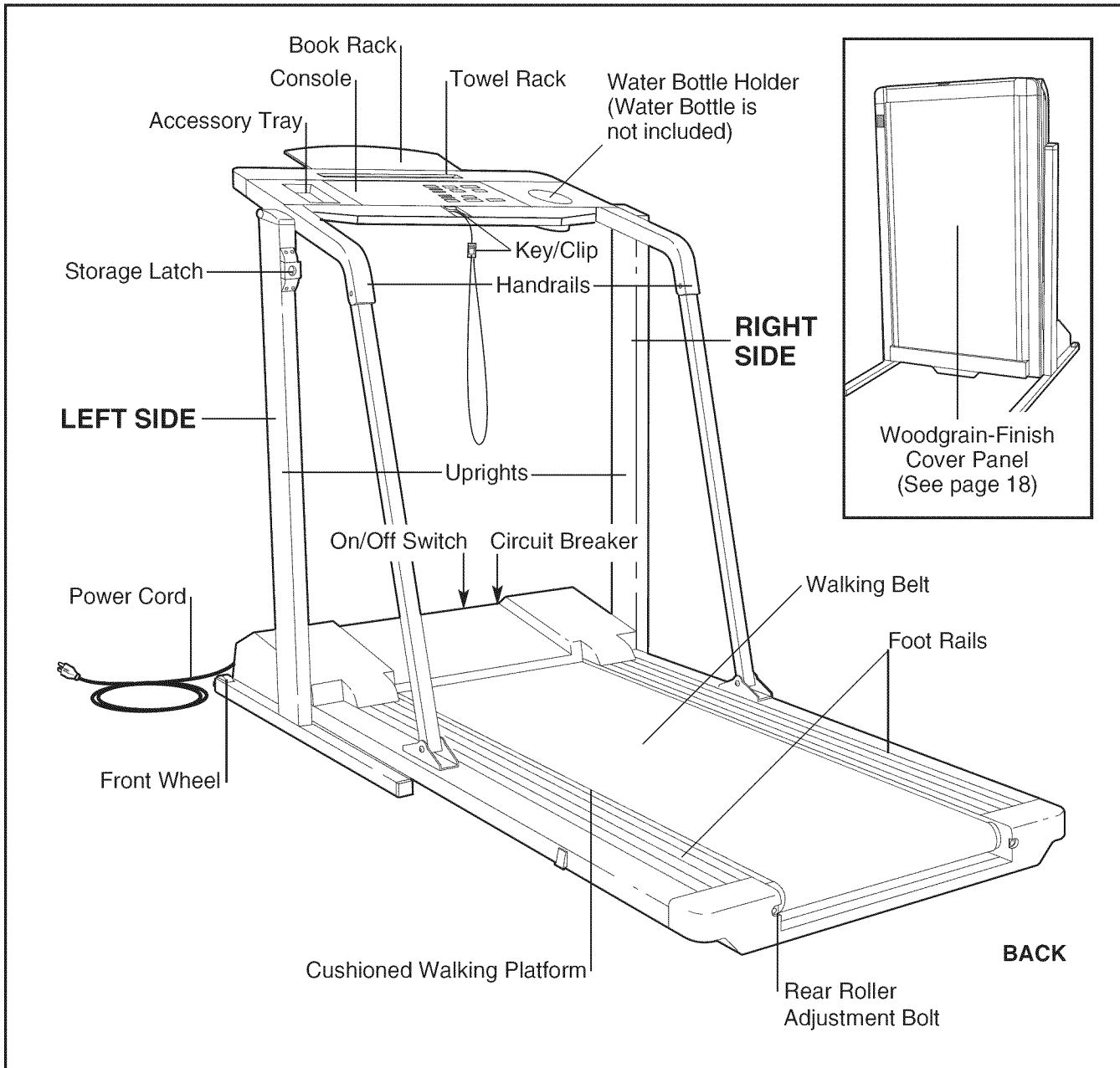

# ASSEMBLY

Assembly requires two people. Set the treadmill in a cleared area and remove the packing materials. Do not dispose of the packing materials until assembly is completed. **Assembly requires the included allen wrench , a phillips screwdriver and scissors (not included) .**

1. Refer to the drawing on page 4 and identify the right side of the treadmill. With the help of a second person, carefully lay the treadmill on its right side; **do not lay the treadmill on its left side or the storage latch may be damaged.**

Firmly slide a Base Extension (76) into one side of the Base (86). Using the Allen Wrench (89), tighten an Extension Bolt (13) into the Base Extension and the Base. While the treadmill is on its side, attach the other Base Extension (not shown) in the same manner.

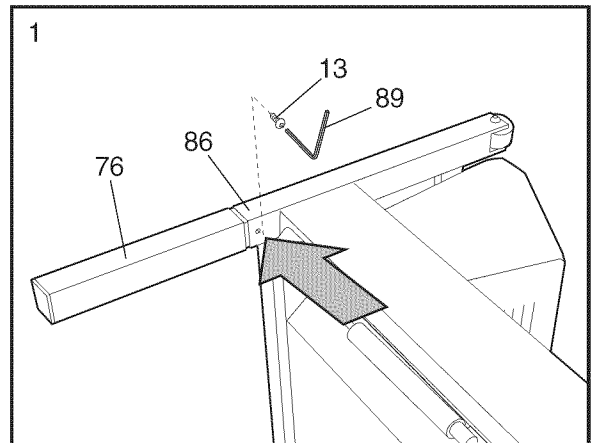

2. Attach six Base Pads (43) to the Base (86) and the Base Extensions (76) in the indicated locations. Note: One extra Base Pad may be included.

With the help of a second person, carefully raise the treadmill to the upright position so the Base (86) and the Base Extensions (76) are resting on the floor.

Refer to HOW TO LOWER THE TREADMILL FOR USE. Follow the instructions to lower the treadmill.

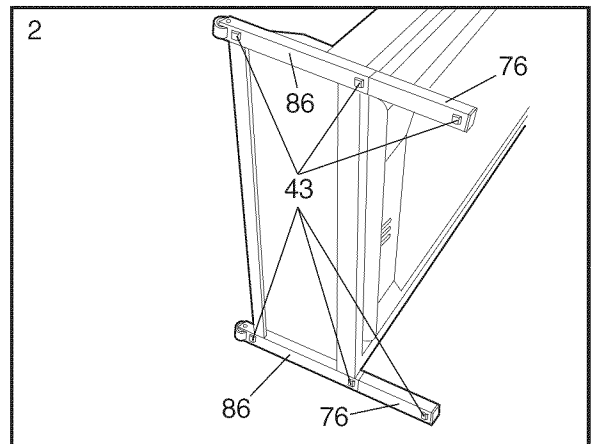

3. Cut the two Shipping Ties from the Handrails (61).

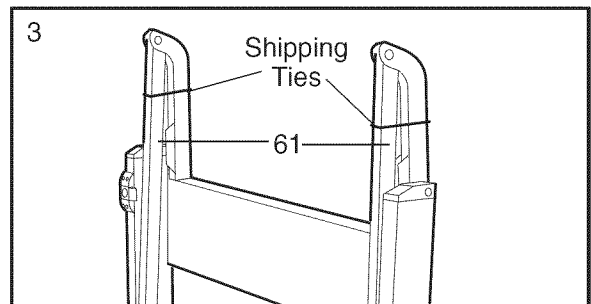

4. Remove the four Handrail Bracket Screws (15) from the right side of the Frame (83). Position the right Handrail Bracket (42) over the four screw holes in the Frame. Loosely thread two of the Screws into the back holes of the Bracket and into the Frame as shown.

Repeat this step on the left side of the Frame (83).

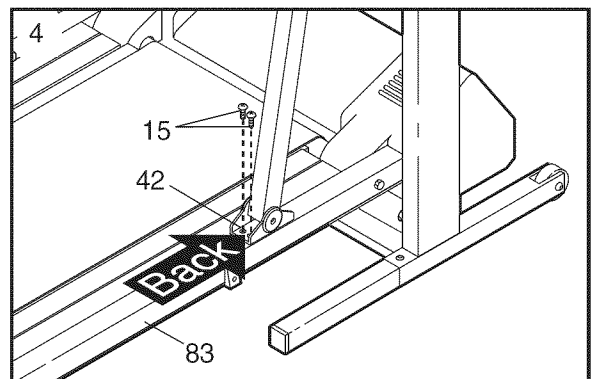

5. Locate the section HOW TO FOLD THE TREADMILL FOR STORAGE on page 18. Follow the instructions to fold the treadmill.

Thread two more Handrail Bracket Screws (15) into the right Handrail Bracket (42) and Frame (83). Firmly tighten all four Screws in the Bracket. Thread two more Screws into the left Handrail Bracket and Frame (not shown). Firmly tighten all four Screws in the Bracket.

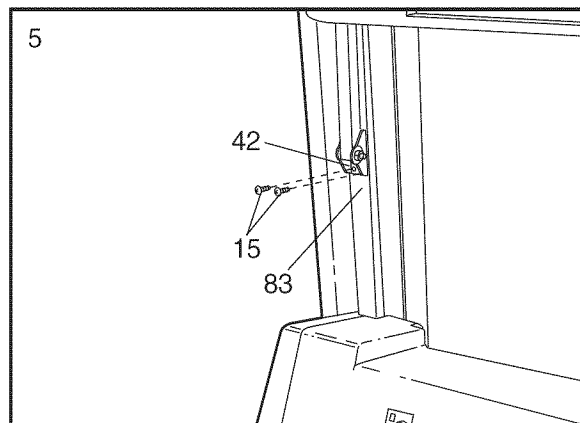

6. Refer to HOW TO LOWER THE TREADMILL FOR USE on page 19. Follow the instructions to lower the treadmill.

Align the holes in the Book Rack (101) with the holes in the Console Base (85). Attach the Book Rack with the four Console Screws (6) as shown.

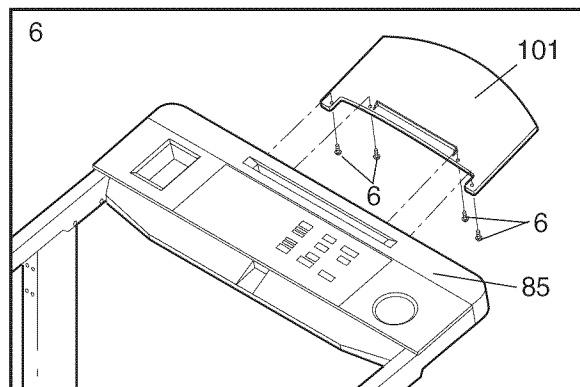

7. Attach the Pulse Sensor (114) to the Headband (115). Make sure that the sensor window is pressed through the indicated hole in the Headband.

Press open the clothes clip, and insert the pulse sensor wire into the clothes clip. **Make sure that the pulse sensor wire is resting against the hinge of the clothes clip (see the inset drawing).** The use of the pulse sensor is explained on page 8.

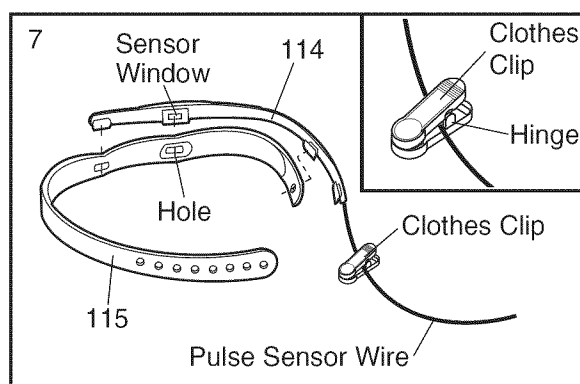

8. Remove the backing from the Adhesive Clip (90). Press the Clip onto the Upright Base (86) in the indicated location. Press the Allen Wrench (89) into the Clip.

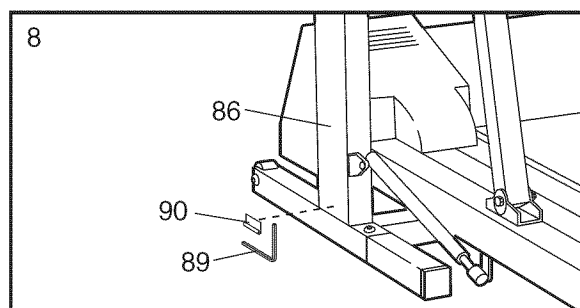

9. Make sure that all parts are tightened before you use the treadmill. **Note: To protect the floor or carpet, place a mat under the treadmill. For information on ordering a mat, see REPLACEMENT PARTS on the back cover.**

# HOW TO USE THE PULSE SENSOR

The unique headband-style pulse sensor is specially designed for greater accuracy, comfort, and durability. **To get the best performance from the pulse sensor, please read the following instructions.**

## HOW TO ADJUST THE HEADBAND

For the pulse sensor to function properly, the headband should fit snugly around your head, without being uncomfortable.

To adjust the headband, insert the adjustment tab through one of the holes in the headband. **Note: Each time you exercise,**

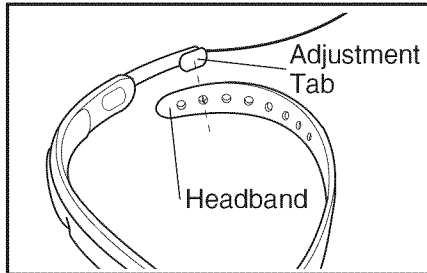

**the headband may expand slightly during the first few minutes of use. It may be necessary to readjust the headband periodically.**

## HOW TO PUT ON THE PULSE SENSOR

Rub your forehead briefly to stimulate circulation. Put on the headband as shown below, with the sensor window centered on your forehead. Make sure that there is no hair between the sensor window and your forehead. Attach the clothes clip to your collar. The clothes clip will reduce the movement of the pulse sensor wire, helping to ensure accurate pulse readings.

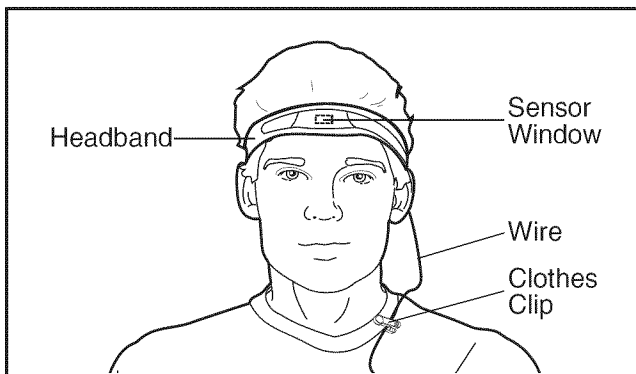

**IMPORTANT: To avoid static build-up that may damage the console, wear the pulse sensor only while you are on the treadmill.**

## GUIDELINES FOR ACCURATE PULSE READINGS

The instructions on page 12 explain how the pulse sensor is used with the console (see PULSE

DISPLAY). For the best results, remember the following important guidelines:

1. Before putting on the headband, rub your forehead briefly to stimulate circulation.
2. Make sure that the headband fits snugly, without being uncomfortable. If the headband is too loose or too tight, your pulse may not be detected.
3. The headband must be worn with the sensor window centered on your forehead. Make sure that there is no hair between the sensor window and your forehead. Make-up applied to the forehead may interfere with pulse readings. Note: If the pulse sensor does not detect your pulse when the sensor window is centered on your forehead, try positioning the sensor window above your right or left eyebrow. Depending on the shape of your forehead, it may be easier to detect your pulse from a different position.
4. Make sure that the pulse sensor wire is fully plugged into the jack on the console.
5. Because your pulse constantly changes, the pulse sensor will sample your pulse every few seconds. When you first put on the pulse sensor, it may take up to ten seconds for an accurate pulse to be shown.
6. Avoid excessive head movement during exercise.
7. The sensor window should be cleaned weekly when the treadmill is used regularly. Moisten a cotton swab with water, and carefully wipe the sensor window.

## HOW TO SOLVE COMMON PULSE PROBLEMS

1. If you are wearing the pulse sensor and the NO PULSE DETECTED indicator lights, refer to guidelines 2, 3, 4, 5, 6, and 7 above.
2. If the pulse shown in the PULSE display seems excessively high or low, refer to guideline 5.
3. If error code "E5" appears in the PULSE display, refer to guidelines 2, 3, 4, 5, 6, and 7.
4. If the letters "PLS" appear in the PULSE display, refer to guidelines 2, 3, 4, 5, 6, and 7.

## CLEANING THE PULSE SENSOR AND HEADBAND

Remove the headband from the pulse sensor. Wipe the pulse sensor with a damp cloth; **never immerse the pulse sensor in water.** Hand wash the headband in mild detergent, gently wring it out, and let it air dry.



# OPERATION AND ADJUSTMENT

## THE PERFORMANT LUBE™ WALKING BELT

Your treadmill features a walking belt coated with PERFORMANT LUBE™, a high-performance lubricant. **IMPORTANT: Never apply silicone spray or other substances to the walking belt or the walking platform. They will deteriorate the walking belt and cause excessive wear.**

## HOW TO PLUG IN THE POWER CORD

**⚠ DANGER:** Improper connection of the equipment-grounding conductor can result in an increased risk of electric shock. Check with a qualified electrician or serviceman if you are in doubt as to whether the product is properly grounded. Do not modify the plug provided with the product—if it will not fit the outlet, have a proper outlet installed by a qualified electrician.

Your treadmill, like any other type of sophisticated electronic equipment, can be seriously damaged by sudden voltage changes in your home's power. Voltage surges, spikes, and noise interference can result from weather conditions or from other appliances being turned on or off.

**To decrease the possibility of your treadmill being damaged, always use a surge protector (not included) with your treadmill.**

Surge protectors are sold at most hardware stores and department stores. Use only a UL-listed surge protector, rated at 15 amps, with a 14-gauge cord of five feet or less in length.

**This product must be grounded.** If it should malfunction or break down, grounding provides a path of least resistance for electric current to reduce the risk

of electric shock. This product is equipped with a cord having an equipment-grounding conductor and a grounding plug. **Plug the power cord into a surge protector, and plug the surge protector into an appropriate outlet that is properly installed and grounded in accordance with all local codes and ordinances.**

This product is for use on a nominal 120-volt circuit, and has a grounding plug that looks like the plug illustrated in drawing 1 below. A temporary adapter that looks like the adapter illustrated in drawing 2 may be used to connect the surge protector to a 2-pole receptacle as shown in drawing 2 if a properly grounded outlet is not available.

The temporary adapter should be used only until a properly grounded outlet (drawing 1) can be installed by a qualified electrician.

The green-colored rigid ear, lug, or the like extending from the adapter must be connected to a permanent ground such as a properly grounded outlet box cover. Whenever the adapter is used it must be held in place by a metal screw. **Some 2-pole receptacle outlet box covers are not grounded. Contact a qualified electrician to determine if the outlet box cover is grounded before using an adapter.**

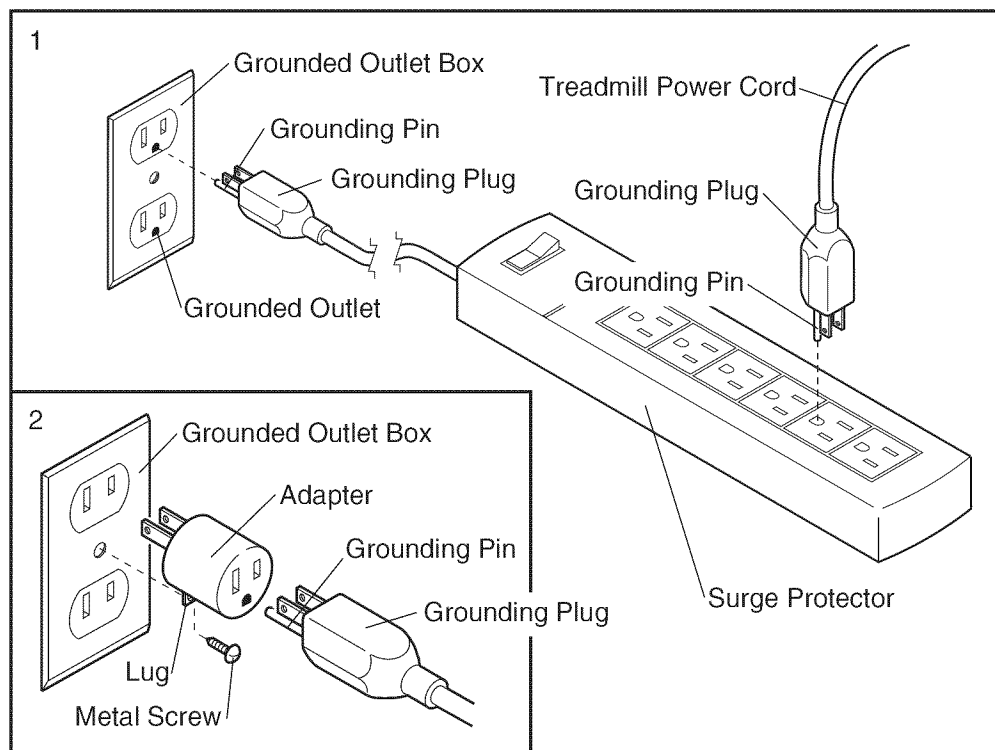

## DIAGRAM OF THE CONSOLE

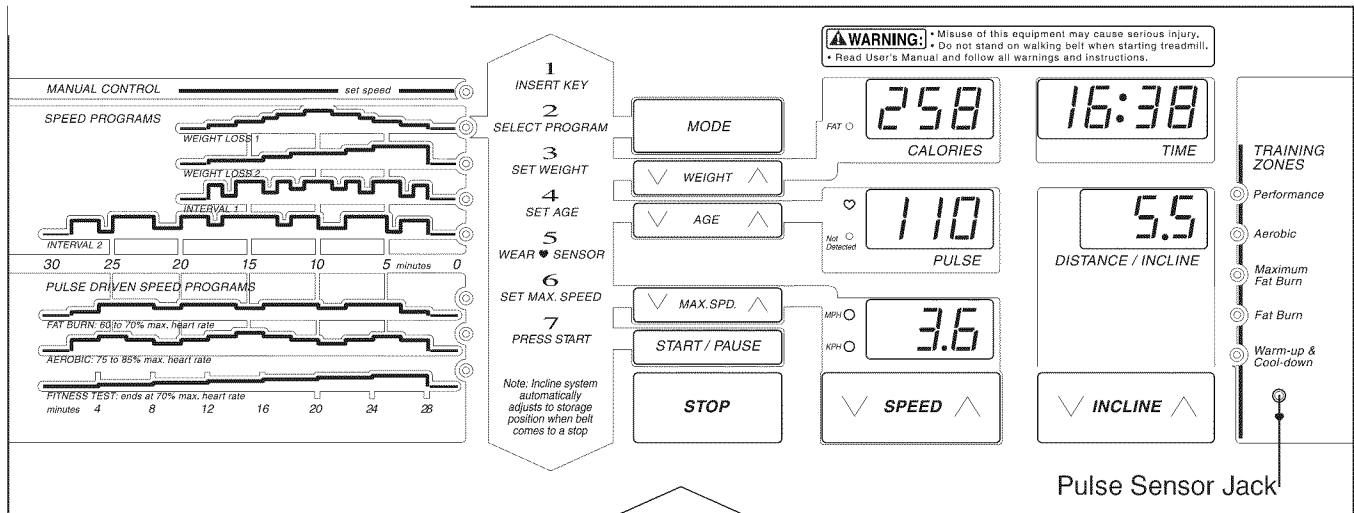

Key

Note: If there is a thin sheet of clear plastic on the face of the console, remove it.

Clip

### **CAUTION:** Before operating the console, read the following precautions.

- Do not stand on the walking belt when turning on the power or starting the walking belt.
- Always wear the clip (see the drawing above) while operating the treadmill. If the key is pulled from the console, the walking belt will stop.
- The treadmill is capable of high speeds. Adjust the speed in small increments.
- The pulse sensor is not a medical device. Various factors, including the user's movement, may affect the accuracy of pulse readings. The pulse sensor is intended only as an exercise aid in determining pulse trends in general.
- If you have heart problems, or if you are over 60 years of age and have been inactive, *do not use the FAT BURN program or the AEROBIC program.* If you are taking medication regularly, consult your physician to find whether the medication will affect your exercise heart rate.
- To reduce the risk of electric shock, keep the console dry, avoid spilling liquids on the console, and use only a sealed water bottle.

## FEATURES OF THE CONSOLE

The treadmill console offers an impressive array of features designed to make your workouts more effective and enjoyable. When the console is in the manual mode, the speed and incline of the treadmill can be changed with a touch of a button. As you exercise, five displays will provide continuous exercise feedback. Seven preset programs are also offered: two WEIGHT LOSS programs and two INTERVAL programs automatically control the speed of the treadmill as they guide you through effective workouts; the special FAT BURN program provides intensive fat-burning workouts; the AEROBIC program helps you to achieve maximum cardiovascular benefits; and the unique FITNESS TEST program measures your relative fitness level.

To use the manual mode, follow the steps on pages 11 through 13. To use the WEIGHT LOSS or INTERVAL programs, see pages 13 and 14. To use the FAT BURN or AEROBIC program, see pages 15 and 16. To use the FITNESS TEST program, see pages 16 and 17. Note: The console can display speed and distance in either miles or kilometers (see SPEED DISPLAY on page 12). For simplicity, all instructions in this manual refer to miles.

Before beginning, make sure that the on/off switch located near the power cord is in the "on" position. Plug in the power cord (see page 9). Note: If the key is in the console when the power cord is plugged in, the letters "PO" will flash in the SPEED display. If this occurs, remove the key.

"On"  
Position



## HOW TO USE THE MANUAL MODE

### 1 Insert the key fully into the console.

Stand on the foot rails and insert the key. Various displays and indicators will light. Find the clip attached to the key and slide it onto the waistband of your clothing.

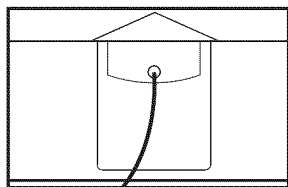

### 2 Select the MANUAL mode.

When the key is inserted, the manual mode will automatically be selected. The MANUAL CONTROL indicator will light. Note: If a preset program has been selected, press the MODE button repeatedly to select the manual mode again.

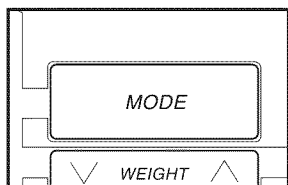

### 3 Enter your weight, if desired.

Although it is not necessary to enter your weight and age to use the manual mode, the CALORIES display will be more accurate if your weight and age are entered. To enter your weight:

- Press the WEIGHT increase or decrease button. The letters “LbS” will flash in the CALORIES display. Press one of the WEIGHT buttons again. The current weight setting will then be shown. Press the WEIGHT buttons again to enter your weight. Each time one of the buttons is pressed, the weight setting will change by 1 pound. If one of the buttons is held down, the weight setting will change in increments of 5 pounds. After you have entered your weight, your weight will be shown in the CALORIES display for three seconds.

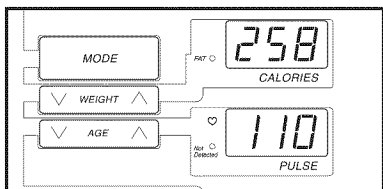

### 4 Enter your age, if desired.

To enter your age:

- Press the AGE increase or decrease button. The letters “AGE” will flash in the PULSE display. Press one of the AGE buttons again. The current age setting will then be shown. Press the AGE

buttons again to enter your age. Each time one of the buttons is pressed, the age setting will change by 1 year. If one of the buttons is held down, the age setting will change in increments of 5 years. After you have entered your age, your age will be shown in the PULSE display for three seconds.

Note: Once you have entered your weight and age, the numbers will be saved in the console's memory, even if the power cord is unplugged.

### 5 Put on the pulse sensor, if desired.

For the PULSE display to show your pulse, the pulse sensor must be worn. To put on the pulse sensor, see HOW TO USE THE PULSE SENSOR on page 8. Plug the pulse sensor fully into the jack on the front of the console.

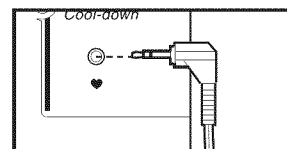

### 6 Press the SPEED increase button to start the walking belt.

The speed of the walking belt is controlled with the SPEED increase and decrease buttons.

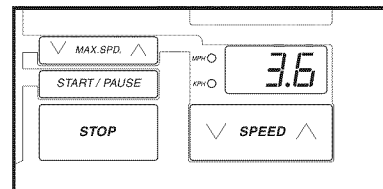

Each time one of the buttons is pressed, the speed will change by 0.1 mile per hour (mph). The buttons can be held down to change the speed quickly. The speed range is 0.5 mph to 10 mph.

Press the SPEED increase button until the walking belt begins to move at slow speed. Hold the handrails and carefully begin walking. Change the speed of the walking belt as desired by pressing the SPEED buttons. Note: The walking belt can also be started by pressing the START/PAUSE button. The walking belt will begin to move at 0.5 mph. The speed can then be adjusted with the SPEED buttons.

To stop the walking belt, press the START/PAUSE button. All displays will pause and the TIME display will begin to flash. To restart the walking belt, press the SPEED buttons or the START/PAUSE button as described above. Note: The walking belt can also be stopped by pressing the STOP button. To restart the walking belt, press the SPEED buttons or the START/PAUSE button as described above.

Note: When the SPEED buttons are pressed, the SPEED display will show the selected speed setting for seven seconds. The display will then show the actual speed of the walking belt.

## 7 Change the incline of the treadmill, if desired.

The incline of the treadmill is controlled with the INCLINE increase and decrease buttons. Each time one of the buttons is pressed, the incline will change by 0.5%.

The buttons can be held down to change the incline quickly. The incline setting is shown in the DISTANCE/INCLINE display. The incline range is 1.5% to 10%. Note: After the INCLINE buttons are pressed, it may take a few seconds for the treadmill to reach the selected incline setting.

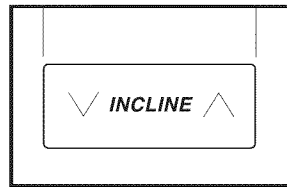

## 8 Follow your progress with the five displays and the TRAINING ZONE monitor.

### • CALORIES display

This display shows both the *total calories* and the number of *fat calories* that you have burned. (See BURNING FAT on page 22 for an explanation of fat calories). Every seven seconds, the display will change from one number to the other. The FAT indicator beside the display will light when the number of fat calories is shown.

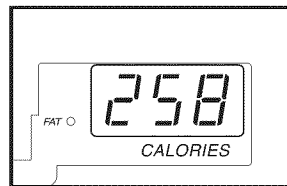

Note: This display also shows the current weight setting when the walking belt is stopped and the WEIGHT buttons are pressed.

### • PULSE display

For this display to operate, the pulse sensor must be worn (see HOW TO USE THE PULSE SENSOR on page 8). After a few seconds, the heart-shaped indicator beside the PULSE display will flash each time your heart beats, the NOT DETECTED indicator will darken, and your pulse will be shown. Note: Because your pulse constantly changes, the pulse sensor will sample your pulse every few seconds. *It may take up to ten seconds before an accurate pulse is shown.* If your pulse is not shown, see GUIDELINES FOR ACCURATE PULSE READINGS on page 8.

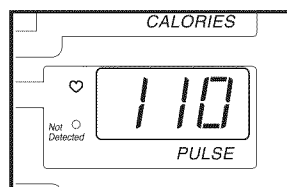

Note: This display also shows the current age setting when the walking belt is stopped and the AGE buttons are pressed.

### • SPEED display

This display shows the current speed of the walking belt. When the SPEED buttons are pressed, the display will show the selected speed setting for seven seconds. The display will then show the actual speed of the walking belt.

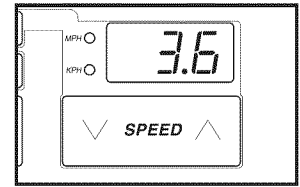

Note: The speed can be displayed in either miles per hour (mph) or kilometers per hour (kph). The indicators beside the SPEED display will light to show which unit of measurement is selected. To change the unit of measurement, first hold down the STOP button while inserting the key into the console. An "E" (for English system [miles]) or "M" (for Metric system [kilometers]) will appear in the SPEED display. Press the SPEED increase button to change the unit of measurement. Remove and then reinsert the key.

### • TIME display

This display shows the total time that the walking belt has been moving.

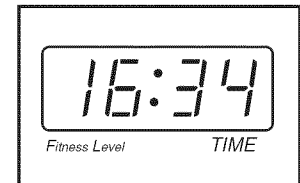

Note: When any program except the FITNESS TEST program is selected, the TIME display will show the time remaining in the program.

### • DISTANCE/INCLINE display

This display shows both the distance that the walking belt has moved and the current incline of the treadmill. Every seven seconds, the display will change from one number to the other. When the INCLINE buttons are pressed, the display will change to show the selected incline setting.

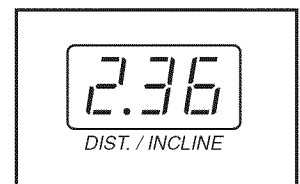

Note: If the MPH indicator beside the SPEED display is lit, the distance will be displayed in miles. If the KPH indicator is lit, the distance will be displayed in kilometers.

### • Training Zone Monitor

The training zone monitor measures the approximate intensity of your exercise. The monitor's five indicators are described below:

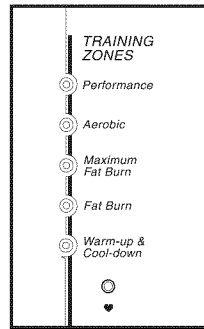

### • WARM UP & COOL DOWN

—Each workout should begin with a warm-up period and end with a cool-down period. (See **WORKOUT GUIDELINES** on pages 22 and 23.) The WARM-UP & COOL-DOWN indicator will light when your workout intensity is ideal for warming up or cooling down.

• **FAT BURN** and **MAXIMUM FAT BURN**—To burn fat effectively, you must exercise at a relatively low intensity level for a sustained period of time. (See **BURNING FAT** on page 22.) If you are exercising at the proper intensity level for burning fat, the **FAT BURN** or **MAXIMUM FAT BURN** indicator will light.

• **AEROBIC**—If your goal is to strengthen your cardiovascular system, your exercise must be “aerobic.” (See **AEROBIC EXERCISE** on page 22.) If you are exercising at the proper intensity level for aerobic exercise, the **AEROBIC** indicator will light.

• **PERFORMANCE**—If your goal is high performance athletic conditioning, you will need to exercise at a high intensity level. If you are exercising at the proper intensity level, the **PERFORMANCE** indicator will light.

## 9 When you are finished exercising, stop the walking belt and remove the key.

Step onto the foot rails and stop the walking belt. Lower the treadmill to the lowest incline level. Remove the key from the console and store the key in a secure place. In addition, move the on/off switch to the “off” position. (See the drawing near the bottom of page 10.)

## HOW TO USE THE WEIGHT LOSS PROGRAMS AND THE INTERVAL PROGRAMS

The **WEIGHT LOSS** programs and the **INTERVAL** programs automatically control the speed of the walking belt as they guide you through effective workouts. The **WEIGHT LOSS** programs focus on helping you to lose unwanted pounds; the **INTERVAL** programs are designed to build stamina. The **WEIGHT LOSS** programs and the **INTERVAL 1** program are 20-minute programs; the **INTERVAL 2** program is a 30-minute program. The graphs on the left side of the console show how the speed will change during each program. During the **WEIGHT LOSS 1** program, for example, the speed will gradually increase during the first 10 minutes, and then gradually decrease during the last 10 minutes. Each program begins with a 2-minute warm-up period, and ends with a 2-minute cool-down period.

Follow the steps below to use one of these programs.

### 1 Make sure that the key is fully inserted into the console.

Stand on the foot rails and insert the key. Various displays and indicators will light. Find the clip attached to the key, and slide it onto your waistband.

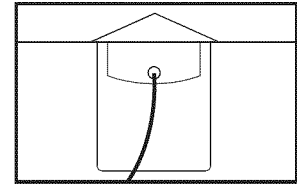

### 2 Select the **WEIGHT LOSS 1**, **WEIGHT LOSS 2**, **INTERVAL 1**, or **INTERVAL 2** program.

When the key is inserted, the **MANUAL CONTROL** indicator will light. To select the **WEIGHT LOSS 1** program, press the **MODE** button. The **WEIGHT LOSS 1** indicator will light. To select one of the other programs, press the **MODE** button repeatedly until the **WEIGHT LOSS 2**, **INTERVAL 1**, or **INTERVAL 2** indicator lights. Note: If the walking belt is moving, it will slow to a stop.

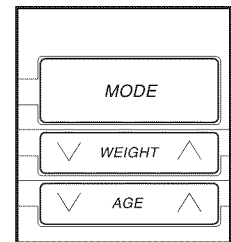

### 3 Enter your weight, if desired.

When a **WEIGHT LOSS** or **INTERVAL** program is selected, the letters “LbS” will flash in the **CALORIES** display for seven seconds; the current weight setting will then be shown. Although it is not necessary to enter your weight and age to use one of these programs, the **CALORIES** display will be more accurate if your weight and age are entered. If you want to enter your weight, see step 3 on page 11.

#### 4 Enter your age, if desired.

After you have completed step 3, the letters “AGE” will flash in the PULSE display for seven seconds; the current age setting will then be shown. If you want to enter your age, see step 4 on page 11.

#### 5 Put on the pulse sensor, if desired.

For the PULSE display to show your pulse, the pulse sensor must be worn. To put on the pulse sensor, see HOW TO USE THE PULSE SENSOR on page 8.

Plug the pulse sensor fully into the jack on the front of the console.

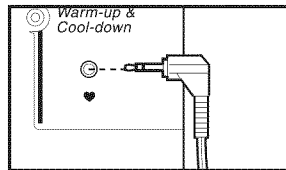

#### 6 Set a maximum speed for the program.

After you have completed step 4, a number will appear in the SPEED display and flash for seven seconds.

This number shows the *maximum speed* that the walking belt will move during the program. The maximum speed setting can be from 3.0 mph to 8.5 mph. If you want to change the maximum speed setting, press the MAX. SPD. increase or decrease button. Note: The maximum speed setting will change by 0.3 mph each time one of the MAX. SPD. buttons is pressed, until it reaches 4.5 mph; the maximum speed setting will then change by 0.5 mph each time one of the buttons is pressed until it reaches 8.5 mph.

If the maximum speed setting is between 3.0 mph and 5.0 mph, the walking belt will move at 1.5 mph during the first 2 minutes and the last 2 minutes of the program (the warm-up and cool-down periods). The *speed range* during the rest of the program will be 1.5 mph. For example, if the maximum speed setting is 5.0 mph, the *speed range* will be 3.5 mph to 5.0 mph (a difference of 1.5 mph).

If the maximum speed setting is between 5.5 mph and 8.5 mph, the walking belt will move at 3.0 mph during the first 2 minutes and the last 2 minutes of the program. The *speed range* during the rest of the program will be 2.0 mph.

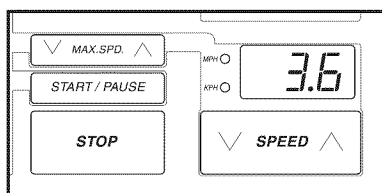

#### 7 Press the START/PAUSE button to start the program.

When the START/PAUSE button is pressed, the TIME display will begin counting down

from 20 minutes (or 30 minutes if the INTERVAL 2 program is selected). After a moment, the walking belt will begin to move. Hold the handrails and carefully begin walking.

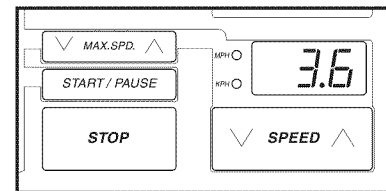

As the program progresses, the speed of the walking belt will change periodically as shown by the graphs on the left side of the console. The program will continue until the time shown in the TIME display reaches zero. The walking belt will then slow to a stop and the program will be completed. **Note: During the last ten seconds of the program, the treadmill will automatically adjust to the lowest incline level. Keep your feet and objects from beneath the treadmill.**

Note: The SPEED buttons will not respond while a WEIGHT LOSS or INTERVAL program is selected. If the program is too easy or too challenging, press the MAX. SPD. buttons to set a new maximum speed. The new maximum speed setting will be shown in the SPEED display for 3 seconds. To stop the program temporarily, press the START/PAUSE button. The TIME display will begin to flash. To restart the program, press the START/PAUSE button again. The program will resume and the walking belt will return to the latest speed setting. To terminate the program before the program is completed, press the STOP button.

#### 8 Change the incline of the treadmill, if desired.

When a WEIGHT LOSS or INTERVAL program is selected, the incline of the treadmill can be changed with the INCLINE buttons. See step 7 on page 12.

#### 9 Follow your progress with the five displays and the TRAINING ZONE monitor.

See TRAINING ZONE MONITOR on page 13.

#### 10 When you are finished exercising, stop the walking belt and remove the key.

Step onto the foot rails, stop the walking belt, and remove the key from the console. Store the key in a secure place. In addition, move the on/off switch to the “off” position. (See the drawing near the bottom of page 10.)

## HOW TO USE THE FAT BURN AND AEROBIC PROGRAMS

The FAT BURN and AEROBIC programs automatically control the speed and incline of the treadmill to keep your pulse within a predetermined range during your workouts. Both programs are 30-minute programs. The graphs on the left side of the console show how your pulse will change during each program. Each program begins with a warm-up period, and ends with a cool-down period.

To use one of these programs, follow the steps below.

### 1 Make sure that the key is fully inserted into the console.

Stand on the foot rails and insert the key. Various displays and indicators will light. Find the clip attached to the key, and slide it onto the waistband of your clothing.

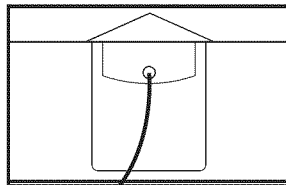

### 2 Select the FAT BURN or AEROBIC program.

Press the MODE button repeatedly until the FAT BURN or AEROBIC indicator lights. Note: If the walking belt is moving, it will slow to a stop.

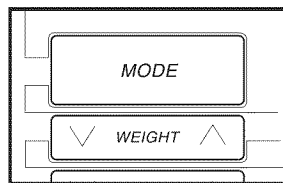

### 3 Enter your weight.

When the FAT BURN or AEROBIC program is selected, the letters "LbS" will flash in the CALORIES display. You must enter your weight and age before either of these programs can be started. To enter your weight, see step 3 on page 11. If you have already entered your weight, you must press one of the WEIGHT buttons to verify the weight setting.

### 4 Enter your age.

After you have completed step 3, the letters "AGE" will flash in the PULSE display. To enter your age, see step 4 on page 11. If you have already entered your age, you must press one of the AGE buttons to verify the age setting.

### 5 Put on the pulse sensor.

The pulse sensor must be worn when the FAT BURN or AEROBIC program is used. To put on the pulse sensor, see HOW TO USE

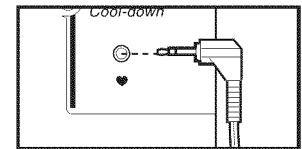

THE PULSE SENSOR on page 8. Plug the pulse sensor fully into the jack on the front of the console. Note: The FAT BURN and AEROBIC programs can be started without your pulse being detected; however, the programs will automatically stop if your pulse is not detected 2 minutes after the programs are started.

### 6 Press the START/PAUSE button to start the program.

When the START/PAUSE button is pressed, the TIME display will begin counting down from 30 minutes. After a moment, the walking belt will begin to move. Hold the handrails and carefully begin walking.

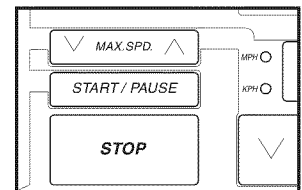

As the program progresses, the speed and incline of the treadmill will change periodically to keep your pulse within a predetermined range, shown by the graphs on the left side of the console. When the time shown in the TIME display reaches zero, the walking belt will slow to a stop and the program will be completed. **Note: During the last ten seconds of the program, the treadmill will automatically adjust to the lowest incline level. Keep your feet and objects from beneath the treadmill.**

Note: If your pulse is not detected during the program, the NOT DETECTED indicator will light and the letters "PLS" will flash in the PULSE display. (See

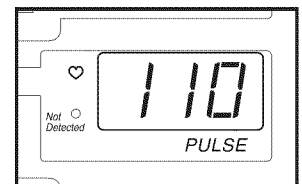

GUIDELINES FOR ACCURATE PULSE READINGS on page 8.) If your pulse is not detected at the end of any 2-minute period during the program (after 2 minutes, after 4 minutes, after 6 minutes, etc.), the program will automatically stop.

Note: Minor adjustments can be made to the speed or incline of the treadmill during the program by pressing the SPEED or INCLINE buttons. However, if you increase the speed, the incline will automatically decrease; if you decrease the speed, the incline will automatically increase. If you increase the

incline, the speed will automatically decrease; if you decrease the incline, the speed will automatically increase. *The console will always attempt to keep your pulse near a predetermined setting.* When the incline reaches the highest setting, the speed cannot be decreased any further. When the incline reaches the lowest setting, the speed cannot be increased any further.

Note: To stop the program temporarily, press the START/PAUSE button. The TIME display will begin to flash. To restart the program, press the START/PAUSE button again. The program will resume and the walking belt will return to the latest speed setting. To terminate the program before the program is completed, press the STOP button.

**7 Follow your progress with the five displays and the TRAINING ZONE monitor.**

See TRAINING ZONE MONITOR on pages 12 and 13.

**8 When you are finished exercising, stop the walking belt and remove the key.**

Step onto the foot rails, stop the walking belt, and remove the key from the console. Store the key in a secure place. In addition, move the on/off switch to the “off” position. (See the drawing near the bottom of page 10.)

**HOW TO USE THE FITNESS TEST PROGRAM**

The FITNESS TEST program is designed to measure your relative fitness level. For the best results, the FITNESS TEST should be taken at a time when your energy level is high. The FITNESS TEST should not be taken if you have already exercised during the day.

The FITNESS TEST program consists of seven 4-minute periods, and is followed by a 2-minute cool-down period. The speed and/or incline of the treadmill will automatically increase at the beginning of each 4-minute period.

To use the FITNESS TEST program, follow the steps below.

**1 Make sure that the key is fully inserted into the console.**

Stand on the foot rails and insert the key. Various displays and indicators will light. Find the clip attached to the key, and slide it onto the waistband of your clothing.

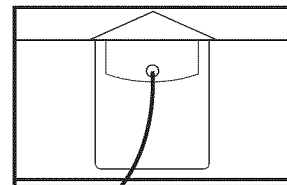

**2 Select the FITNESS TEST program.**

To select the FITNESS TEST program, press the MODE button repeatedly until the FITNESS TEST indicator lights. Note: If the walking belt is moving, it will slow to a stop.

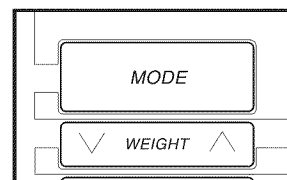

**3 Enter your weight.**

When the FITNESS TEST program is selected, the letters “Lbs” will flash in the CALORIES display. You must enter your weight and age before this program can be started. To enter your weight, see step 3 on page 11. If you have already entered your weight, you must press one of the WEIGHT buttons to verify the weight setting.

**4 Enter your age.**

After you have completed step 3, the letters “AGE” will flash in the PULSE display. To enter your age, see step 4 on page 11. If you have already entered your age, you must press one of the AGE buttons to verify the age setting.

**5 Put on the pulse sensor.**

The pulse sensor must be worn when the FITNESS TEST program is used. To put on the pulse sensor, see HOW TO USE THE PULSE

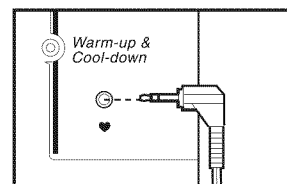

SENSOR on page 8. Plug the pulse sensor fully into the jack on the front of the console. Note: The FITNESS TEST program can be started without your pulse being detected; however, the program will automatically stop if your pulse is not detected 4 minutes after the program is started.



## 6 Press the START/PAUSE button to start the program.

When the START/PAUSE button is pressed, the TIME display will begin counting up. The CALORIES display will show “L 1” (level 1), indicating that the first 4-minute period of the FITNESS TEST program has begun. The incline of the treadmill will automatically adjust to 3.0%, and the walking belt will begin to move at 1.5 mph. Hold the handrails and carefully begin walking.

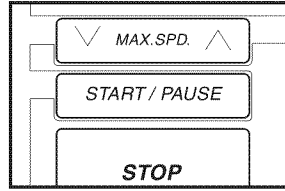

When the TIME display reaches 4 minutes, the CALORIES display will show “L 2,” indicating that the second 4-minute period has begun. The incline will increase to 4%, and the speed will increase to 2.5 mph. At the beginning of each 4-minute period, the speed and/or incline of the treadmill will automatically increase. The FITNESS TEST will continue in this manner *until your pulse reaches 70% of your maximum heart rate, and the current 4-minute period is completed. The FITNESS TEST will then be completed, regardless of how many periods remain.*

When the FITNESS TEST is completed, the letter “C” will be shown in the CALORIES display, indicating that the cool-down period has begun. The TIME display will count down from 2 minutes. When the cool-down period is completed, the walking belt will slow to a stop. **Note: During the last ten seconds of the cool-down period, the treadmill will automatically adjust to the lowest incline level. Keep your feet and objects from beneath the treadmill.** After the program is completed, your fitness level will be shown in the TIME display. There are ten fitness levels—fitness level 10 (FL:10) is the highest. Remember, the FITNESS TEST is intended only to indicate your relative fitness level.

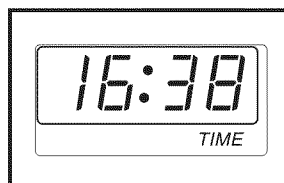

Note: The SPEED and INCLINE buttons will not respond while the FITNESS TEST program is selected. If your pulse is not detected during the program, the NOT DETECTED indicator will light and the letters “PLS” will flash in the PULSE display. If your pulse is not detected during the last thirty seconds of any 4-minute period (after 4 minutes,

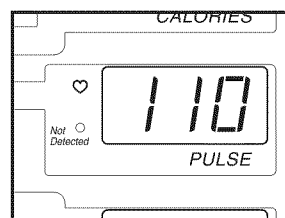

after 8 minutes, etc.), the walking belt will slow to a stop, the FITNESS TEST will end, and the TIME display will show a fitness level of 0 (FL:00). (See GUIDELINES FOR ACCURATE PULSE READINGS on page 8.) The FITNESS TEST program cannot be stopped temporarily and then restarted. However, the program can be stopped at any time by pressing the STOP button. The TIME display will then show an estimated fitness level. If the STOP button is pressed a second time, the MANUAL mode will be selected.

## 7 When you are finished exercising, stop the walking belt and remove the key.

Step onto the foot rails, stop the walking belt, and remove the key from the console. Store the key in a secure place. In addition, move the on/off switch to the “off” position. (See the drawing near the bottom of page 10.)

### HOW TO SELECT THE INFORMATION MODE

The console features an information mode that keeps track of the total time and distance accumulated on the treadmill.

To access the information mode, hold down the STOP button while inserting the key into the console. The TIME display will show the total time accumulated on the treadmill, in hours. The DISTANCE/INCLINE display will show the total distance, in miles (if the total distance exceeds 999 miles, the thousands and ten thousands digits will be shown in the PULSE display). Note: The SPEED display will show an “E” (for English system [miles]) or “M” (for Metric system [kilometers]) (see SPEED DISPLAY on page 12).

To exit the information mode, remove the key.

# HOW TO FOLD AND MOVE THE TREADMILL

## HOW TO FOLD THE TREADMILL FOR STORAGE

Before folding the treadmill, adjust the incline to the lowest position. **If the incline is not at the lowest position, the treadmill will be permanently damaged.** Next, unplug the power cord. **Caution: You must be able to safely lift 45 pounds (20 kg) in order to raise, lower, or move the treadmill.**

1. Hold the treadmill with your hands in the locations shown at the right. **Caution: To avoid pinching your hands, do not hold the treadmill in the locations indicated by the arrows.** To decrease the possibility of injury, bend your legs and keep your back straight. As you raise the treadmill, make sure to lift with your legs rather than your back. Raise the treadmill about halfway to the vertical position.

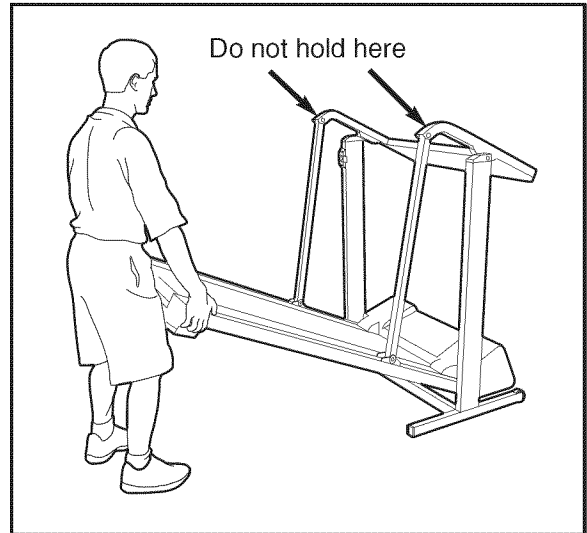

2. Move your right hand to the position shown and hold the treadmill firmly. Raise the treadmill until the storage latch closes over the frame guide. **Make sure that the storage latch closes fully over the frame guide.**

**To protect the floor or carpet from damage, place a mat under the treadmill. Keep the treadmill out of direct sunlight. Do not leave the treadmill in the storage position in temperatures above 85° Fahrenheit.**

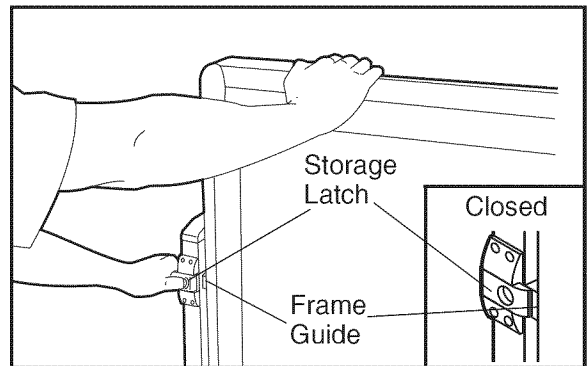

## THE WOODGRAIN-FINISH COVER PANEL

When the treadmill is in the storage position, the woodgrain-finish cover panel will accent the decor of your room. If desired, you can remove the cover panel to display the black-finish frame cover instead. To remove the cover panel, simply insert your fingers between the lower end of the cover panel and the frame cover (see the arrow at the right). Pull the cover panel off the panel fasteners, working your way up until the cover panel is removed.

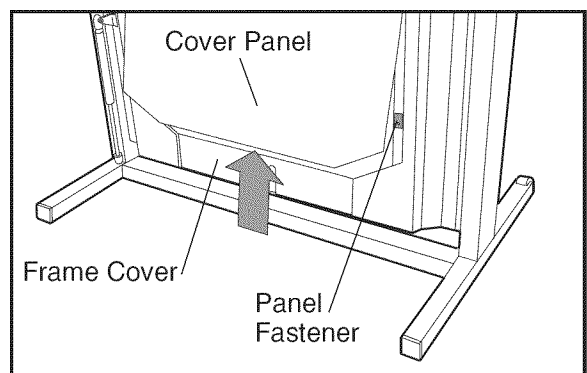

After the cover panel is removed, the panel fasteners can be removed for a cleaner appearance. Using a phillips head screwdriver, remove one of the panel screws and panel fasteners from the frame cover. Tighten the panel screw back into the frame cover. Repeat this process, **removing one panel fastener at a time**, until all six panel fasteners are removed. Press the removed panel fasteners onto the fasteners on the back of the cover panel. Store the cover panel away from moisture and dust.

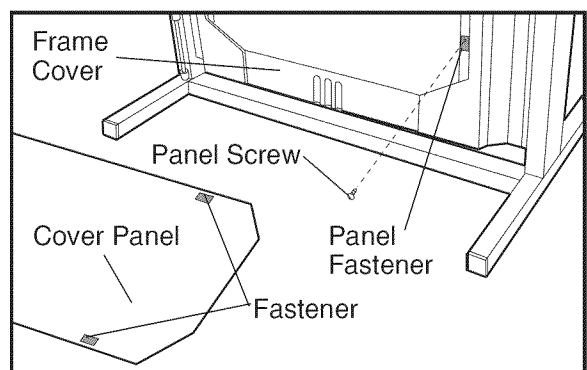

## HOW TO MOVE THE TREADMILL

Before moving the treadmill, convert the treadmill to the storage position as described above. **Make sure that the storage latch is closed fully over the frame guide.**

1. Hold the upper ends of the treadmill. Place one foot on the base as shown.
2. Tilt the treadmill back until it rolls freely on the front wheels. Carefully move the treadmill to the desired location. **Never move the treadmill without tipping it back, or the base pads may come off. To reduce the risk of injury, use extreme caution while moving the treadmill. Do not attempt to move the treadmill over an uneven surface.**
3. Place one foot on the base, and carefully lower the treadmill until it is resting in the storage position.



## HOW TO LOWER THE TREADMILL FOR USE

1. Hold the upper end of the treadmill with your right hand as shown. Using your left thumb, slide open the storage latch and hold it open. Pivot the treadmill until the frame is past the storage latch.
2. Hold the treadmill firmly with both hands, and lower the treadmill to the floor. **Caution: To avoid pinching your hands, do not hold the treadmill in the locations indicated by the arrows. To decrease the possibility of injury, bend your legs and keep your back straight.**

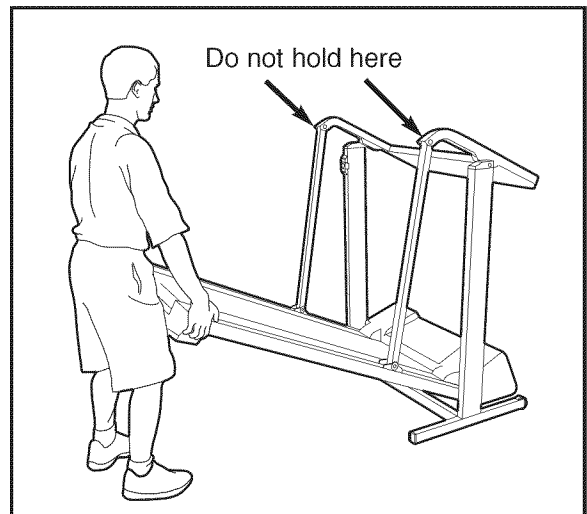
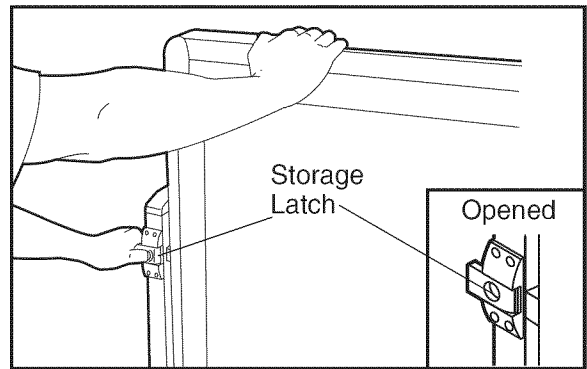



---

# TROUBLE-SHOOTING

Most treadmill problems can be solved by following the steps below. Find the symptom that applies, and follow the steps listed.

If further assistance is needed, call our toll-free HELPLINE at 1-800-736-6879, Monday through Saturday, 7 a.m. until 7 p.m. Central Time (excluding holidays).

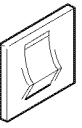
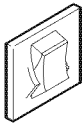
## 1. SYMPTOM: THE POWER DOES NOT TURN ON

- Make sure that the power cord is plugged into a surge protector, and that the surge protector is plugged into a properly grounded outlet. (See HOW TO PLUG IN THE POWER CORD on page 9.) Use only a UL-listed surge protector, rated at 15 amps, with a 14-gauge cord of five feet or less in length.
- After the power cord has been plugged in, make sure that the key is fully inserted into the console. (See step 1 on page 11.)
- Check the circuit breaker located on the treadmill near the power cord. If the switch protrudes as shown, the circuit breaker has tripped. To reset the circuit breaker, wait for five minutes and then press the switch back in.
- Check the on/off switch located at the front of the treadmill near the power cord. The switch must be in the "on" position.

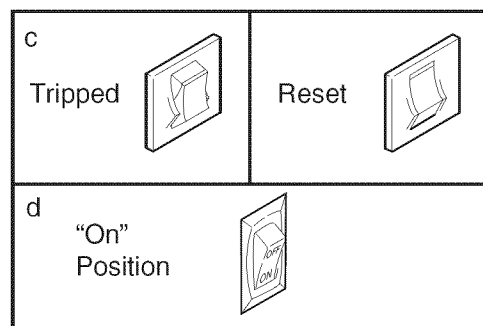

## 2. SYMPTOM: THE POWER TURNS OFF DURING USE

- Check the circuit breaker located on the treadmill frame near the power cord (see 1. c. above). If the circuit breaker has tripped, wait for five minutes and then press the switch back in.
- Make sure that the power cord is plugged in.
- Remove the key from the console. Reinsert the key fully into the console. (See step 1 on page 11.)
- Check to make sure that the on/off switch is in the "on" position. (See 1. d. above.)
- If the treadmill still will not run, please call our toll-free HELPLINE.

## 3. SYMPTOM: THE WALKING BELT SLOWS WHEN WALKED ON

- Use only a UL-listed surge protector, rated at 15 amps, with a 14-gauge cord of five feet or less in length.
- If the walking belt still slows when walked on, please call our toll-free HELPLINE.

## 4. SYMPTOM: AN ERROR CODE ("E2," "E3," "E4," OR "E5") APPEARS ON THE CONSOLE

- Error code "E2" may appear in the SPEED display if the SPEED increase or START/PAUSE button is pressed and no movement of the walking belt is detected within seven seconds. Remove the key, wait for ten seconds, and then reinsert it. Make sure that you stand on the foot rails of the treadmill each time you start the walking belt. If the error code appears again, call our toll-free Customer Service Department. Do not operate the treadmill until the problem is corrected.
- Error code "E3" may appear in the SPEED display if the speed of the walking belt surges above the selected speed setting. Remove the key, wait for ten seconds, and then reinsert it. If the error code appears again, call our toll-free Customer Service Department. Do not operate the treadmill until the problem is corrected.

c. Error code “E4” may appear in the SPEED display if the walking belt is moving at a slow speed, and there is excessive stress on the motor. Remove the key, wait for ten seconds, and then reinsert it. If you weigh over 200 pounds, it may be helpful to increase the incline of the treadmill. If the error code appears again, call our toll-free Customer Service Department. Do not operate the treadmill until the problem is corrected.

d. Error code “E5” may appear in the PULSE display if a pulse error occurs. See HOW TO USE THE PULSE SENSOR on page 8, and PULSE DISPLAY on page 12.

#### 5. SYMPTOM: THE PULSE SENSOR DOES NOT FUNCTION PROPERLY

a. See HOW TO USE THE PULSE SENSOR on page 8, and PULSE DISPLAY on page 12.

#### 6. SYMPTOM: THE WALKING BELT IS OFF-CENTER WHEN WALKED ON

a. If the walking belt has shifted to the left, first remove the key and **UNPLUG THE POWER CORD**. Using the allen wrench, turn the left rear roller adjustment bolt clockwise 1/4 of a turn. Plug in the power cord, insert the key and run the treadmill for a few minutes. Repeat until the walking belt is centered.

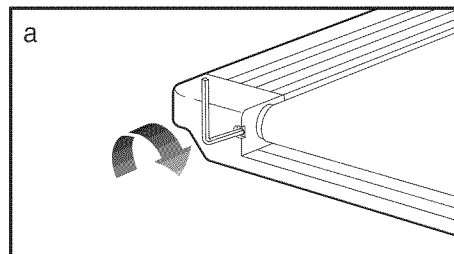

b. If the walking belt has shifted to the right, first remove the key and **UNPLUG THE POWER CORD**. Using the allen wrench, turn the left rear roller adjustment bolt counterclockwise 1/4 of a turn. Plug in the power cord, insert the key and run the treadmill for a few minutes. Repeat until the walking belt is centered.

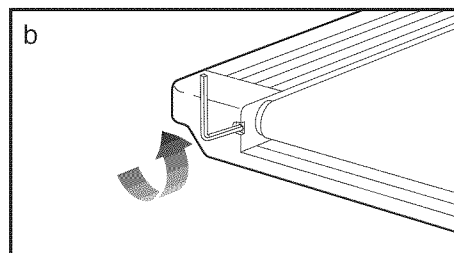

#### 7. SYMPTOM: THE TREADMILL SITS UNEVENLY ON THE FLOOR

a. Make sure that the six base pads are attached to the treadmill. See assembly step 2 on page 6.

# CONDITIONING GUIDELINES

**⚠ WARNING:** Before beginning this or any exercise program, consult your physician. This is especially important for individuals over the age of 35 or individuals with pre-existing health problems.

The pulse sensor is not a medical device. Various factors, including your movement, may affect the accuracy of heart rate readings. The sensor is intended only as an exercise aid in determining heart rate trends in general.

The following guidelines will help you to plan your exercise program. Remember—these are general guidelines. For more detailed information about exercise, obtain a reputable book or consult your physician.

## EXERCISE INTENSITY

Whether you want to burn fat, strengthen your cardiovascular system, or increase your athletic performance, you can tailor your exercise to your specific goals. The key to achieving the desired results is to exercise with the proper intensity.

### Burning Fat

To burn fat effectively, you must exercise at a relatively low intensity level for a sustained period of time. During the first few minutes of exercise, your body uses easily accessible *carbohydrate calories* for energy. Only after the first few minutes of exercise does your body begin to use stored *fat calories* for energy. If your goal is to burn fat, adjust the speed and incline of the treadmill until the FAT BURN indicator is lit. (See TRAINING ZONE MONITOR on page 13.)

### Aerobic Exercise

If your goal is to strengthen your cardiovascular system, your exercise must be “aerobic.” Aerobic exercise is activity that requires large amounts of oxygen for prolonged periods of time. This increases the demand on the heart to pump blood to the muscles, and on the lungs to oxygenate the blood. The proper intensity level for aerobic exercise can be found by using your pulse as a guide. As you exercise, your pulse should be kept at a level between 70% and 85% of your maximum possible heart rate. This is known as your training zone. You can find your training zone in the table at the top of this page. Training zones are listed according to age and physical condition.

Age	Training Zone (Beats/Min.)	
	Unconditioned	Conditioned
20	138-167	133-162
25	136-166	132-160
30	135-164	130-158
35	134-162	129-156
40	132-161	127-155
45	131-159	125-153
50	129-156	124-150
55	127-155	122-149
60	126-153	121-147
65	125-151	119-145
70	123-150	118-144
75	122-147	117-142
80	120-146	115-140
85	118-144	114-139

keep your pulse near the low end of your training zone as you exercise. After a few months of regular exercise, your pulse can be gradually increased until it is near the middle of your training zone as you exercise. You can measure your pulse using the pulse sensor. Exercise for about four minutes, and then measure your pulse immediately. If your pulse is too high or too low, adjust the intensity of your exercise. It may also be helpful to adjust the speed and incline of the treadmill until the AEROBIC indicator is lit. (See TRAINING ZONE MONITOR on page 13.)

### Performance Training

If your goal is high performance athletic conditioning, adjust the speed and incline of the treadmill until the PERFORMANCE indicator is lit. (See TRAINING ZONE MONITOR on page 13.)

## WORKOUT GUIDELINES

Each workout should include three parts: (1) a warm-up, (2) training zone exercise, and (3) a cool-down.

### Warm-up

Warming up prepares the body for exercise by increasing circulation, delivering more oxygen to the muscles and raising the body temperature. Begin each workout with 5 to 10 minutes of stretching and light exercise to warm up (see SUGGESTED STRETCHES on page 23).

## Training Zone Exercise

After warming up, increase the intensity of your exercise until your pulse is in your training zone for 20 to 60 minutes. (During the first few weeks of your exercise program, do not keep your pulse in your training zone for longer than 20 minutes.) Breathe regularly and deeply as you exercise—never hold your breath.

## Cool-down

Finish each workout with 5 to 10 minutes of stretching

to cool down. This will increase the flexibility of your muscles and will help to prevent post-exercise problems.

## Exercise Frequency

To maintain or improve your condition, complete three workouts each week, with at least one day of rest between workouts. After a few months, you may complete up to five workouts each week if desired.

*The key to success is to make exercise a regular and enjoyable part of your everyday life.*

## SUGGESTED STRETCHES

The correct form for several basic stretches is shown in the drawings below. Move slowly as you stretch—never bounce.

### 1. Toe Touch Stretch

Stand with your knees bent slightly and slowly bend forward from your hips. Allow your back and shoulders to relax as you reach down toward your toes as far as possible. Hold for 15 counts, then relax. Repeat 3 times. Stretches: Hamstrings, back of knees and back.

### 2. Hamstring Stretch

Sit with one leg extended. Bring the sole of the opposite foot toward you and rest it against the inner thigh of your extended leg. Reach toward your toes as far as possible. Hold for 15 counts, then relax. Repeat 3 times for both legs. Stretches: Hamstrings, lower back and groin.

### 3. Calf/Achilles Stretch

With one leg in front of the other, reach forward and place your hands against a wall. Keep your back leg straight and your back foot flat on the floor. Bend your front leg, lean forward and move your hips toward the wall. Hold for 15 counts, then relax. Repeat 3 times for both legs. To cause further stretching of the achilles tendons, bend your back leg as well. Stretches: Calves, achilles tendons and ankles.

### 4. Quadriceps Stretch

With one hand against a wall for balance, reach back and grasp one foot with your other hand. Bring your heel as close to your buttocks as possible. Hold for 15 counts, then relax. Repeat 3 times for both legs. Stretches: Quadriceps and hip muscles.

### 5. Inner Thigh Stretch

Sit with the soles of your feet together and your knees outward. Pull your feet toward your groin area as far as possible. Hold for 15 counts, then relax. Repeat 3 times. Stretches: Quadriceps and hip muscles.

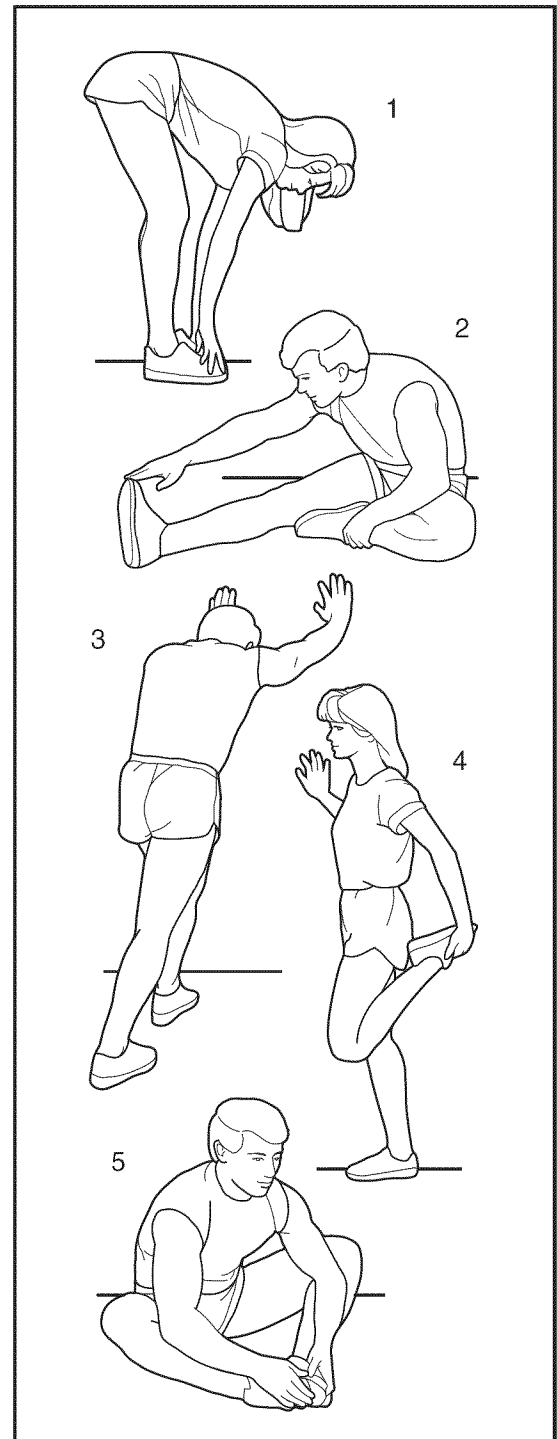

# PART LIST—Model No. 831.297763

R0597A

Key No.	Part No.	Qty.	Description	Key No.	Part No.	Qty.	Description
1	104725	2	Upright Endcap Bolt	72	134574	1	Wire Harness
2	129600	1	Rear Roller Guard	73	137676	6	Cover Fastener
3	100427	10	Nut	74	129004	2	Wire Harness Grommet
4	121421	3	Upright Bracket Bolt	75	134331	1	Shock
5	013322	10	Screw	76	132435	2	Base Extension
6	126996	10	Console Screw	77	134576	1	Power Supply w/Clips
7	132549	1	Ground Wire	78	137858	1	Controller
8	112669	1	Clevis Pin	79	138058	1	Incline Leg
9	106334	1	Cotter Pin	80	132453	1	Belly Pan
10	132449	2	Hex-Head bolt	81	136203	1	Endcap Plug
11	014088	1	Small Star Washer	82	136880	1	Rear Roller Cover
12	117806	2	Base Wheel Bolt	83	NSP	1	Frame
13	013484	2	Extension Bolt	84	134578	1	Walking Platform
14	013300	20	Screw	85	137465	1	Console Base
15	013540	8	Handrail Bracket Screw	86	136073	1	Upright/Base
16	133072	5	Belly Pan Fastener	87	132455	1	Left Endcap Foot
17	013456	4	Endcap Bolt	88	100498	1	Magnet
18	105444	2	Adjustment Bolt (Short)	89	126040	1	Allen Wrench
19	014127	4	Adjustment Washer	90	016028	2	Adhesive Clip
20	013456	4	Frame Isolator Screw	91	118153	1	Reed Switch Wire
21	013576	4	Latch Frame Guide Screw	92	134577	1	Walking Belt
22	134300	2	Isolator	93	136869	1	Frame Cover
23	134302	8	Spring Cushion	94	137409	1	Adjustment Bolt (Long)
24	128272	8	Platform Screw	95	109370	1	Incline Disk
25	054023	3	Wire Clip	96*	137357	1	Motor/Pulley/Flywheel/Fan
26	128986	1	Tension Spring	97	126747	1	Pulley/Flywheel/Fan
27	123470	1	Spring Sleeve	98	134649	1	Frame Cover Panel
28	121576	3	Roller Tension Nut	99	136377	2	Latch Spring
29	132456	2	Spacer	100	132424	1	Right Handrail Arm
30	135665	1	Right Endcap Foot	101	135025	1	Book Rack
31	127597	6	Endcap Fastener	102	132441	1	Right Upright Endcap
32	114270	2	Incline Motor Spacer	103	016057	5	8" Wire Tie
33	120630	18	Small Screw	104	131605	1	Latch Warning Decal
34	120354	2	Upright Pivot Bolt	105	119038	1	Key/Clip
35	013547	1	Motor Tension Bolt	106	129232	2	Storage Warning Decal
36	014117	1	Star Washer	107	135004	1	Choke Plate
37	122812	1	Motor Tension Washer	108	129168	5	Cover Screw
38	120867	1	Motor Tension Nut	109	134338	1	Incline Cover Shield
39	107503	1	Motor Pivot Bolt	110	134337	1	Incline Cover
40	132434	4	Spring	111	134594	6	Cover Screw/Panel Screw
41	132440	1	Upright Endcap (left)	112	125871	1	Motor/Controller Wire
42	132422	2	Handrail Bracket	113	129639	1	Battery Cover
43	129740	7	Base Pad	114	127731	1	Pulse Sensor/Clothes Clip
44	125677	5	Hood Anchor	115	126481	1	Headband
45	052012	2	Front Wheel	116	119163	1	On/Off Switch
46	103833	2	Base Extension Endcap	117	119070	1	Speed Disk
47	132394	5	Hood Bracket	118	138691	1	Optic Switch Bracket
48	125819	4	Plastic Stand-off	119	012152	2	Small Nut
49	130251	2	Frame Guide	120	122125	1	Optic Switch Nut
50	130993	1	Choke	121	102955	2	Optic Switch
51	134347	1	Bracket	122	102959	2	Small Bolt
52	138863	8	Upright Plug	123	126911	2	Optic Switch Wire Harness
53	109382	1	Circuit Breaker	124	014063	2	Roller Cover Washer
54	131753	1	Storage Latch Bracket	125	116892	1	Incline Bracket
55	131738	1	Storage Latch	126	013375	1	Incline Bolt
56	132466	1	Electronics Bracket	127	119425	3	Incline Nut
57	109265	2	Belt Guide	128	131562	2	Latch Pad
58	134303	1	Rear Roller	129	013529	5	Anchor Screw
59	134305	1	Front Roller/Pulley	130	133333	6	Clip
60	134570	2	Foot Rail	131	014073	6	Handrail Washer
61	132426	2	Handrail	132	135922	2	Handrail Cover
62	132565	1	Left Handrail Arm	#	127860	12	Fastener
63	134571	1	Hood	#	107771	1	8" White Wire, Male/Female
64	134346	2	Handrail Arm Spacer	#	109407	1	4" Black Wire, 2 Female
65	134388	2	Frame Spacer	#	102643	1	8" Green Ground Wire
66	134572	1	Console	#	112083	1	8" Blue Wire, 2 Female
67	137356	1	Motor	#	102246	1	8" White Wire, 2 Female
68	135866	1	Motor Belt	#	139004	1	User's Manual
69	139085	1	Incline Motor				
70	124669	1	Power Cord				
71	124695	1	Grommet				

\* Includes all parts shown in the box

# These parts are not illustrated



# EXPLODED DRAWING—Model No. 831.297763

R0597A

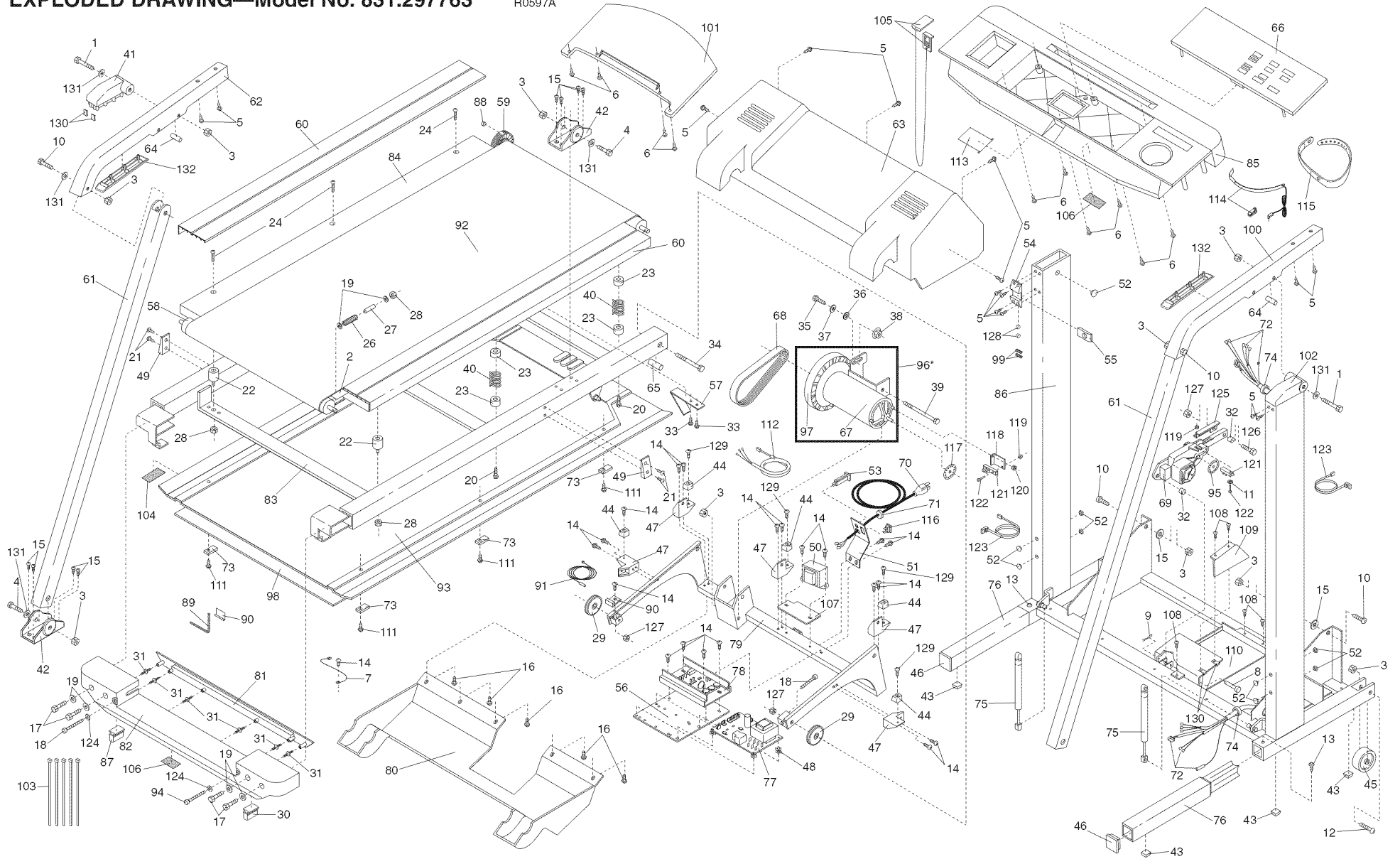



Model No. 831.297763

## QUESTIONS?

If you find that:

- you need help assembling or operating the PROFORM® 725 TL treadmill
- a part is missing
- or you need to schedule repair service

call our toll-free HELPLINE

**1-800-736-6879**

Monday–Saturday, 7 am–7 pm  
Central Time (excluding holidays)

## REPLACEMENT PARTS

If parts become worn and need to be replaced, call the following toll-free number

**1-800-FON-PART**  
**(1-800-366-7278)**

The model number and serial number of your PROFORM® 725 TL treadmill are listed on a decal attached to the frame. See the front cover of this manual to find the location of the decal.

All replacement parts are available for immediate purchase or special order when you visit your nearest SEARS Service Center. To request service or to order parts by telephone, call the toll-free numbers listed at the left.

When requesting help or service, or ordering parts, please be prepared to provide the following information:

- The NAME OF THE PRODUCT (PROFORM® 725 TL treadmill)
- The MODEL NUMBER OF THE PRODUCT (831.297763)
- The PART NUMBER OF THE PART (see the EXPLODED DRAWING and PART LIST included in this manual)
- The DESCRIPTION OF THE PART (see the EXPLODED DRAWING and PART LIST included in this manual).