

**ASSEMBLY, OPERATING INSTRUCTIONS
AND PARTS LIST FOR
CRAFTSMAN 9 INCH RADIAL SAW**

MODEL NUMBER 113.29350

The Model Number will be found on a plate attached to your saw, at the left side of the base. Always mention the Model Number in all correspondence regarding the CRAFTSMAN RADIAL SAW or when ordering repair parts.

Carefully read the instructions provided, observe the simple safety precautions and you will have many hours of satisfactory use from your new Craftsman tool.

HOW TO ORDER REPAIR PARTS

All parts listed herein may be ordered through SEARS, ROEBUCK AND CO. or SIMPSONS-SEARS LIMITED. When ordering parts by mail from the catalog order house which serves the territory in which you live, selling prices will be furnished on request or parts will be shipped at prevailing prices and you will be billed accordingly.

WHEN ORDERING REPAIR PARTS, ALWAYS GIVE THE FOLLOWING INFORMATION AS SHOWN IN THIS LIST:

- | | |
|--------------------|--------------------------------|
| 1. The PART NUMBER | 3. The MODEL NUMBER 113.29350 |
| 2. The PART NAME | 4. The NAME of item—RADIAL SAW |

**COAST TO COAST NATION-WIDE
SERVICE FROM SEARS
FOR YOUR CRAFTSMAN RADIAL SAW**



SEARS, ROEBUCK AND CO. and SIMPSONS-SEARS LIMITED in Canada back up your investment with quick, expert mechanical service and genuine CRAFTSMAN replacement parts.

If and when you need repairs or service, call on us to protect your investment in this fine piece of equipment.

**SEARS, ROEBUCK AND CO.-U. S. A.
IN CANADA, SIMPSONS - SEARS LIMITED**



POWER TOOL SAFETY...AND YOU

3 MINUTES of required reading for the home Craftsman... whether this is your first purchase or you're an old hand at power tools.

YOU'VE JUST BOUGHT A QUALITY SEARS TOOL, designed to give you many years of top performance and trouble-free operation. It's also designed with

safety in mind, permitting you to use the tool without concern so long as certain basic rules are observed.

We'd like to call particular attention to some of the more **important rules** to follow for maximum enjoyment of your Sears power tools.

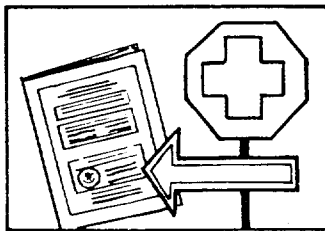

1. READ THE INSTRUCTION MANUAL...

completely - accurately. Pay special attention to safety precautions and use of safety features.

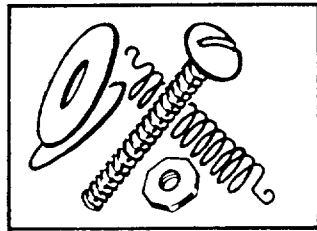

2. INSPECT THE POWER TOOL THOROUGHLY

Set up the machine according to instructions. Make certain all parts are included.

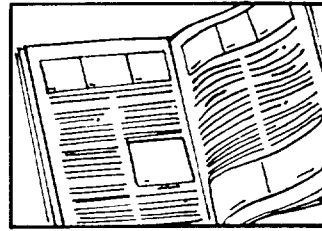

3. FOLLOW OPERATING INSTRUCTIONS CAREFULLY

They have been developed to insure correct procedure and prevent accidents.

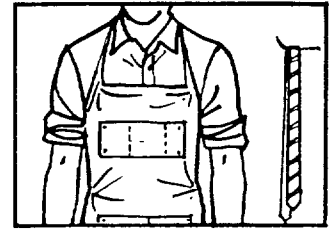

4. DRESS PROPERLY FOR THE WORKSHOP

Get rid of loose clothing, roll up sleeves (or fasten securely), remove your tie, wear a snug-fitting shop apron.

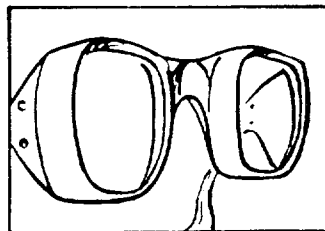

5. WEAR SAFETY GLASSES

Safety glasses or eye shields are recommended for all power tool operations.

6. USE PROPER ELECTRICAL CONNECTIONS

Make certain proper voltage (110 or 220) is used. USE A GROUND WIRE; AND A SUITABLE PLUG, IF REQUIRED. Check fusing requirements of the tool as outlined in the instruction manual.

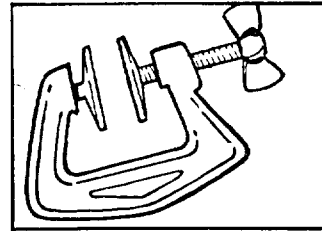

7. DOUBLE-CHECK HOLDING FIXTURES

Lock all clamps tightly. Spin parts by hand to check against misalignment or looseness before turning on tool.

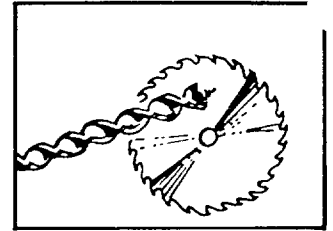

8. KEEP CUTTING TOOLS SHARP

Make certain blades, drills, cutters, etc., are in top shape. Dull tools can cause rough cuts, excessive chipping... and accidents.

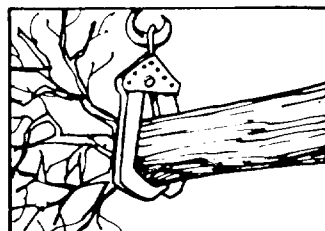

9. DON'T EXCEED THE LIMITS OF THE POWER TOOL

Abusing the power tool by doing work beyond its capacity reduces its life and increases the chance of injury to the operator. Watch especially the sizes of the work and feed rate.



10. KEEP SPECTATORS AWAY

Curiosity and interest on the part of the family is fine, but avoid inspections when the power tool is running.

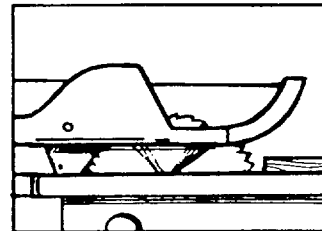

11. SAFETY GUARDS

Accessory safety guards are available for most tools. Use of these guards is highly recommended.

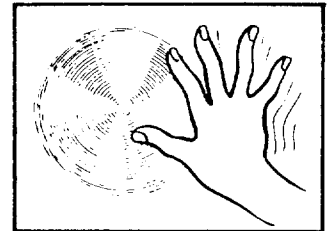

12. AVOID AWKWARD HAND POSITIONS

Do not place hands in a position where a sudden slip could cause them to move into a cutting tool. Do not force work abnormally into any cutting tool.

THINK SAFETY

Carefully plan each operation before turning on tool

ASSEMBLING AND ADJUSTING YOUR SAW

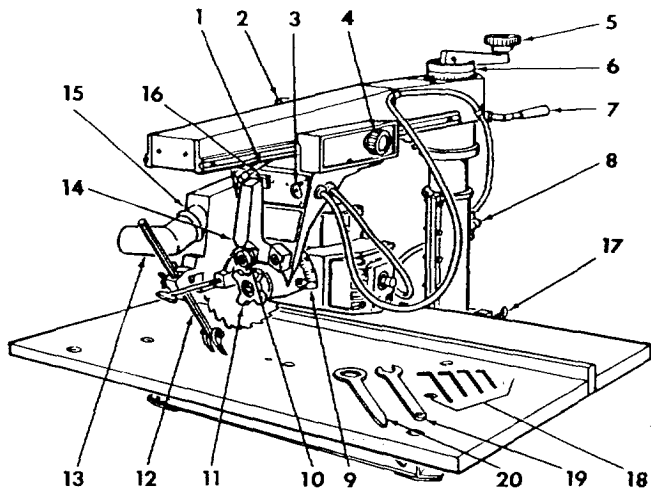

Figure 1

- | | | |
|------------------------------------|--|--|
| 1. Yoke clamp arm | 13. Discharge elbow | |
| 2. Swivel index knob | 14. Handle | |
| 3. Safety lock key | 15. Guard assembly | |
| 4. Carriage lock knob | 16. "ON-OFF" switch | |
| 5. Elevation crank | 17. Table clamp | |
| 6. Radial arm cap | 18. Allen wrench | |
| 7. Arm lock handle | 19. Shaft wrench | |
| 8. Column tube key | 20. Arbor wrench | |
| 9. Bevel index scale and indicator | NOTE: WHEN ORDERING REPAIR PARTS REFER TO PARTS LIST FOR CORRECT PART NUMBER. | |
| 10. Swivel index knob | | |
| 11. Bevel Lock knob | | |
| 12. Anti-kickback pawl assembly | | |

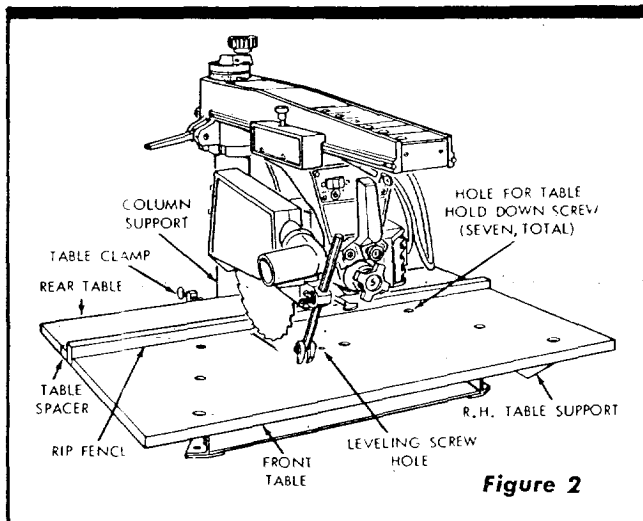

Figure 2

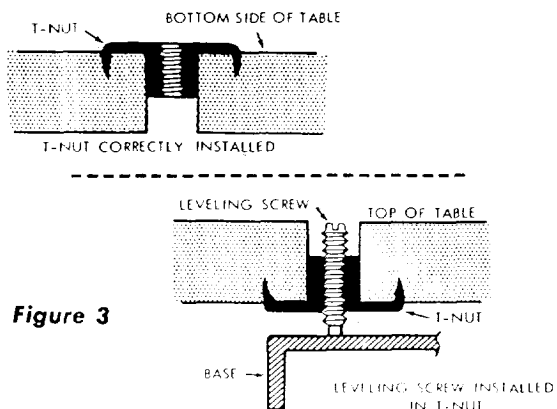

Figure 3

CONNECTING MOTOR TO POWER SUPPLY

The a-c motor used in this Craftsman Radial Saw is of the capacitor start, non-reversible type with the following specifications:

| | |
|----------------------------------|-----------|
| Voltage | 120 |
| Amperes | 9.5 |
| Cycle | 60 |
| Phase | Single |
| RPM | 3450 |
| Rotation (viewing saw blade end) | Clockwise |

CAUTION: This motor is wired for 120 volt operation. Connect to 15 ampere branch circuit and use a 15 ampere time-delay fuse.

MOTOR SAFETY PROTECTION

The saw motor is equipped with a manual-reset thermal overload protector, designed to open the power line circuit when the motor temperature exceeds a safe value.

1. If the protector opens the line and stops the saw motor, press the saw switch to the "OFF" position immediately and allow the motor to cool.
2. After cooling to a safe operating temperature, the overload protector can be closed manually by pushing in the red button on the motor capacitor cover. If the red button will not snap into place immediately, the motor is still too hot and must be allowed to cool for a while longer. (An audible click will indicate protector is closed.)
3. As soon as the red button will snap into running position, the saw may be started and operated normally by pressing the saw switch to the "ON" position.
4. Frequent opening of fuses or circuit breakers may result if motor is overloaded, or if the motor circuit is fused with a fuse other than those recommended. Do not use a fuse of greater capacity without consulting the power company.
5. Although the motor is designed for operation on the voltage and frequency specified on motor nameplate, normal loads will be handled safely on voltages not more than 10% above or below the nameplate voltage. Heavy loads, however, require that voltage at motor terminals be not less than the voltage specified on nameplate.
6. Most motor troubles may be traced to loose or incorrect connections, overloading, reduced input voltage (which results when small size wires are used in the supply circuit) or when the supply circuit is extremely long. Always check connections, load and supply circuit when the motor fails to perform satisfactorily. Check wire sizes and lengths with the table in the next paragraph.

IMPORTANT: The following wire sizes are recommended for connecting the motor to power source for trouble-free operation.

| Length of Conductor | Wire Size Required (American Wire Gauge No.) |
|----------------------------|--|
| 50 feet or less | No. 12 |
| 100 feet or less | No. 10 |
| 100 feet to 150 feet | No. 8 |
| 150 feet to 200 feet | No. 6 |
| 200 feet to 400 feet | No. 4 |

For circuits of greater length the wire size must be increased proportionally.

MOUNTING THE SAW ON A WORK BENCH

The saw should be placed on a suitable sturdy work bench, or Craftsman Power Tool Bench. The base of the saw must be mounted flush to a flat surface on the work bench to prevent distortion of the saw base. The nuts, screws, and washers which attach the wooden shipping skids to the saw base may be used to secure the saw base to the work bench, or tool bench.

ALIGNMENT INSTRUCTIONS

NOTE: The seven basic "steps" that follow are essential in order to insure correct saw table alignment.

WARNING: Make sure the power cord is not plugged into an electrical outlet when working on the saw.

STEP ONE — INSTALLATION OF FRONT TABLE

1. Place the large table board upside-down on floor. Distinguish between the one through-bored (leveling screw) hole near the center of the board, and the seven counterbore holes. (See figure 2.) The counterbores are in the top surface of the board. Drive the T-nut into the through-hole. (See figure 3.)
2. Place the 1/4-20 "U" clip nut on the base cross members to receive the center front table attaching screw.
3. Place the large, front table board on table support angles.
4. Align the counterbore holes with matching holes in the support angles. Place a flat washer and a 1/4-20 x 1" pan-head machine screw in each of the six counterbore holes located above the angles. Use a 1/4-20 x 1-1/4" pan-head machine screw in the counterbore hole at the center of the table board.
5. Start the leveling screw into the T-nut but do not allow the point to protrude beyond bottom surface of front board.
6. Install lockwashers and nuts on the six screws in the angles and tighten them finger tight. Start the 1/4-20 x 1-1/4" pan-head screw in the counterbored hole near the center of front board, leaving it about two turns loose.

STEP TWO — ELIMINATING RADIAL ARM SIDE PLAY

1. Set the radial arm at 0° index position, making sure the arm latch handle is in the detent notch, and tighten the arm lock handle. (See figure 4.)
2. Apply side force with one hand on radial arm in both directions. If side play exists, an adjustment is required.
3. Insert a 3/16-inch Allen wrench into the socket-head set-screw that adjusts the column tube wedge key, as shown in figure 4. Rotate the set-screw slowly in (clockwise) until no side play can be felt in radial arm.
4. Check for binding by rotating the elevation crank. If the crank rotates with noticeable resistance, loosen the set screw by rotating the Allen wrench counterclockwise until rotation is normal. An effective method for finalizing the set-screw adjustment is to rotate the screw while the elevation crank is being rotated, checking for side play in radial arm as the adjustment progresses. The adjustment is correct when all side play of radial arm is eliminated and only very slight additional resistance can be felt when rotating the elevation crank.
5. If some radial arm side play can still be detected after performing the above adjustment, it will be necessary to adjust the forward five screws through the right, and left-hand column supports as follows:
 - a. While rotating the elevation crank, tighten the five column adjusting screws slightly at the forward edge

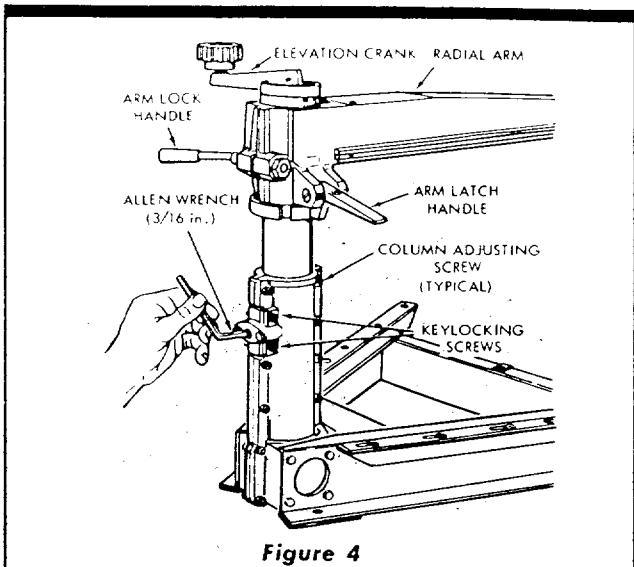

Figure 4

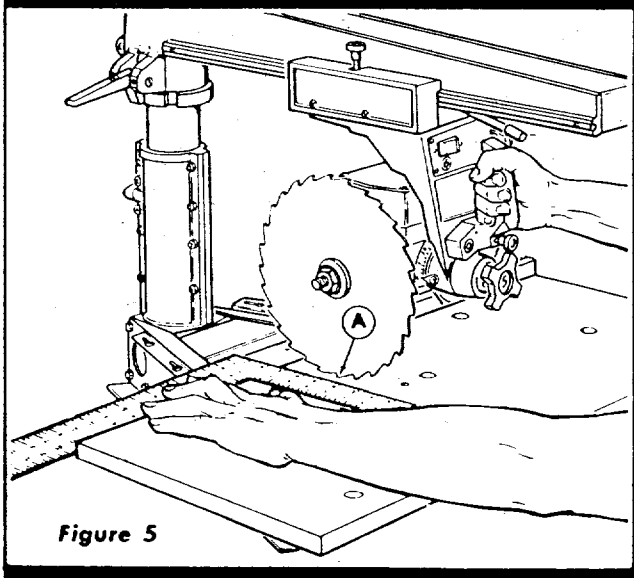

Figure 5

of column supports. Each screw should be tightened only slightly, and each one the same amount, until a slight resistance can be felt when rotating the elevation crank, then each screw backed off just enough to restore a normal feel to the elevation crank.

- b. Recheck the adjustment of the column tube wedge key set-screw as outlined in preceding instructions.
6. After the above adjustments have been completed, recheck the radial arm for absence of side play.
 7. When all side play has been eliminated, lock the column tube key in place by tightening screws at top and bottom of key. (See figure 4.)

STEP THREE — SQUARING THE CROSS CUT TRAVEL

1. Set the radial arm at 0° index position and tighten the arm lock handle. (See figure 4.)
2. Place a square on the table as shown in figure 5 and position the saw and square until the leg of the square just contacts a tooth of the saw blade. (Position "A", figure 5.) Mark this tooth with crayon or chalk.
3. When the blade is moved back and forth on the radial arm, the saw tooth "A" should just touch the square at all positions. If saw tooth "A" does not touch the square at all points, make the following adjustments.

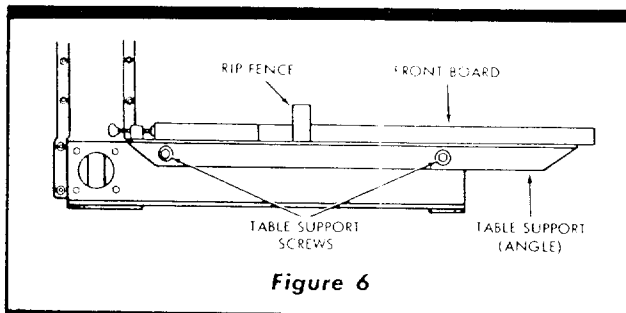

Figure 6

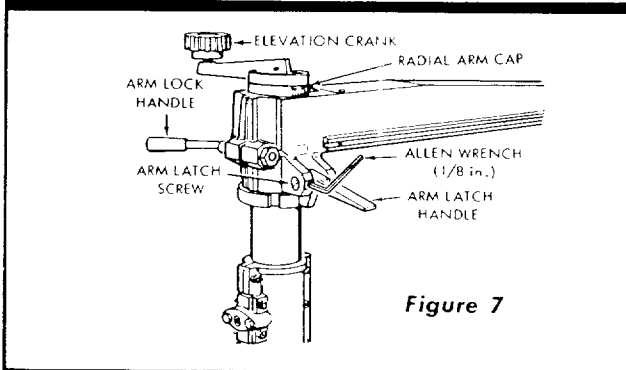

Figure 7

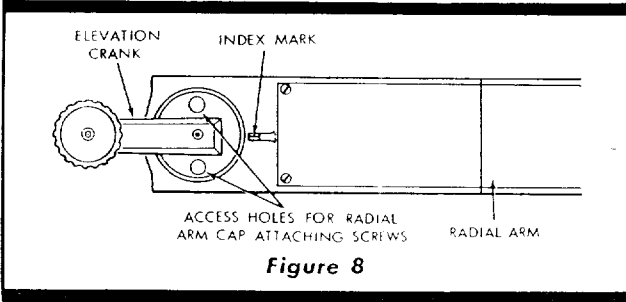

Figure 8

- a. If saw tooth ("A", figure 5) moves away from the square when moving the blade from the rear toward the front of the table, loosen the table screws at the left side and tap the rear edge of front board forward until the table is square with the saw blade. (See figure 6.)
 - b. Recheck blade squareness and, if correct, tighten the six table screws.
 - c. Reverse this procedure if tooth "A" moves into the square when moving the saw table from the rear toward the front of the table.
4. In extreme cases, due to rough handling during shipment, performing the above adjustment procedure may not be sufficient. Make the following adjustment only after tightening the table screws and the cross-cut travel cannot be squared by performing the preceding adjustment routine:
- a. Position the radial arm in 0° position, press arm latch handle down firmly into the detent notch. (See figure 7.)
 - b. Using a 1/8-inch Allen wrench, loosen the two set screws that lock the arm latch screws.
 - c. Move saw blade forward along steel square to determine in which direction the arm must be adjusted.
 - d. If the saw blade moves away from the square as it comes forward, loosen the front arm latch screw and tighten the rear arm latch screw. Check blade travel and repeat if necessary.
 - e. If the saw blade moves toward the square as it comes forward, loosen the rear arm latch screw and tighten

the front arm latch screw. Check blade travel and repeat if necessary.

- f. When the adjustment is correct, both arm latch screws should be snug against the arm latch handle but not tight enough to bind the handle.
 - g. Tighten the Allen set-screws to secure the arm latch screws.
5. After the cross-cut travel has been accurately squared, check the 0° position on the indicator scale of the radial arm cap to determine if the 0° position on the scale is aligned with the index mark on radial arm. (See figure 8.) If not aligned, proceed as follows:
- a. Rotate the elevation crank to a position that will locate the two access holes over screw heads of radial arm cap attaching screws. (See figure 8.)
 - b. Loosen the two screws with a screwdriver inserted through the access holes in lift crank.
 - c. Reposition the radial arm cap by hand until the 0° mark is aligned with the index mark and tighten the two attaching screws.

STEP FOUR — LEVELING THE TABLE PARALLEL TO THE RADIAL ARM

NOTE: DO NOT USE A CARPENTER'S LEVEL.

1. Remove the saw guard.
2. Raise the arm latch handle out of the detent, loosen the arm lock handle (figure 4) and loosen the carriage lock knob (4, figure 1). This will permit easy positioning of saw blade during leveling operations.
3. Lower the saw blade by rotating elevation crank until a tooth just touches the table at the highest spot when saw is moved to points 1, 2, 3, and 4 (POSITION 1, figure 9). This will locate the table high point. Spin the saw blade by hand and listen for "pinging" sound to pick up this high point.
4. Loosen the table support screws at each side just enough to allow the table support angles to slip when tapped with a mallet. (See figure 6.) If too loose, leveling operations will be difficult.

NOTE: Do not change elevation of saw blade during remainder of the leveling operation.
5. Move the saw blade to the low position opposite the high point (located in step 3, above) at the same end of table. Assuming the high area to be at point 1 (POSITION 1, figure 9) the blade would next be moved to point 3 (POSITION 2, figure 9).
6. Using a mallet, tap the table support angle under point 3 until the table top just touches the saw blade.
7. Tighten the two table support screws securely at the left side of frame (figure 6), and recheck by moving saw blade back and forth between points 1 and 3 (POSITION 2, figure 9). If this end of table surface is level, the saw will just touch the table at points from 1 to 3. If not level, readjust point 3.
8. Move the saw blade to point 2 (POSITION 3, figure 9). Tap forward end of right table support angle upward with a mallet until the blade just touches the table surface.
9. Move the saw blade to point 4 (POSITION 4, figure 9) and tap rear end of table support angle upward until the blade just touches the table surface.
10. Tighten the two table support screws securely at the right side of frame (reference figure 6), and move saw blade back and forth between points 2 and 4 (POSITION 4, figure 9) to make sure it touches at all positions from points 2 and 4.
11. Recheck the adjustment by moving saw blade to points 1, 3, 2 and 4 and make corrections if necessary.

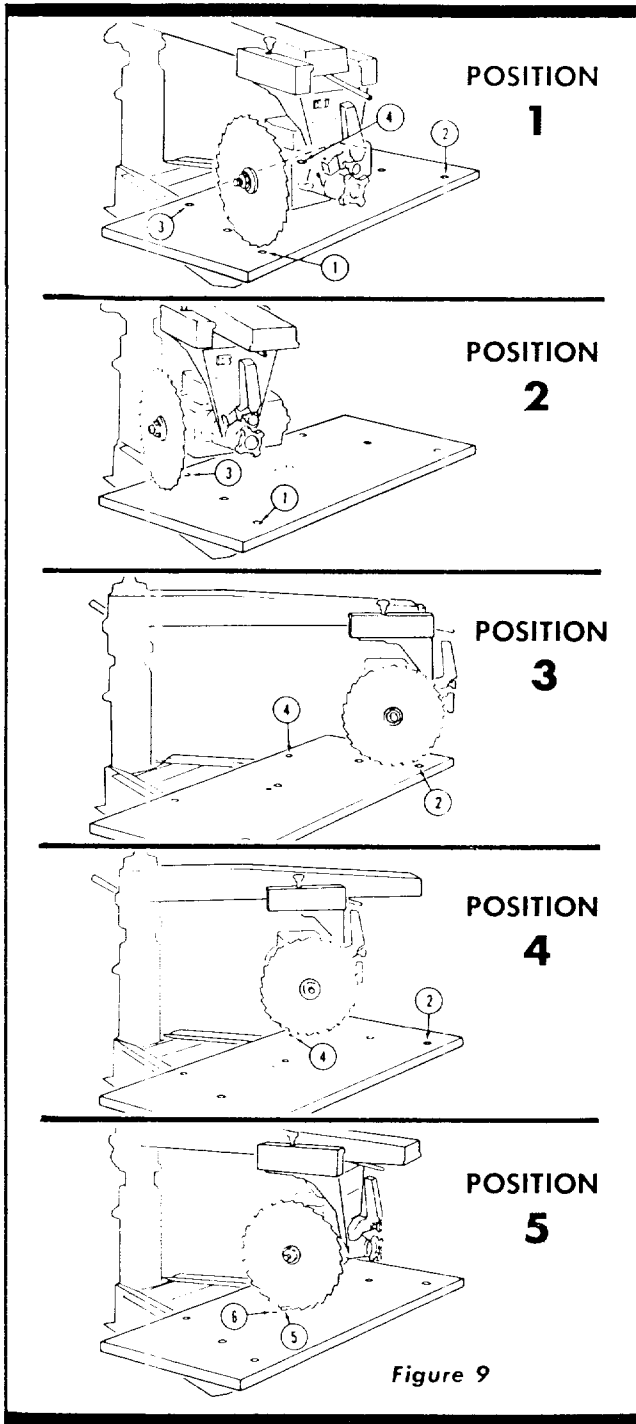

Figure 9

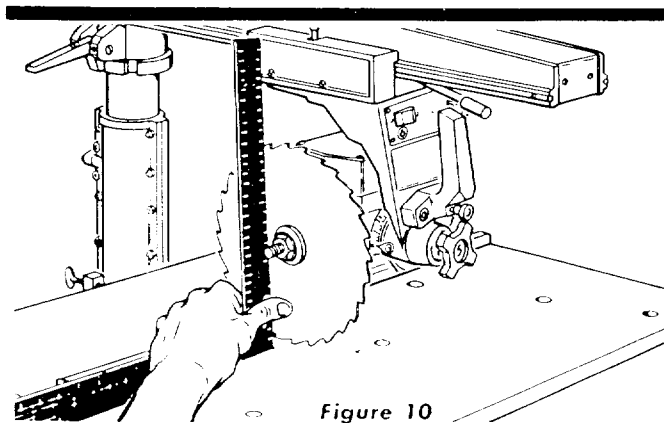

Figure 10

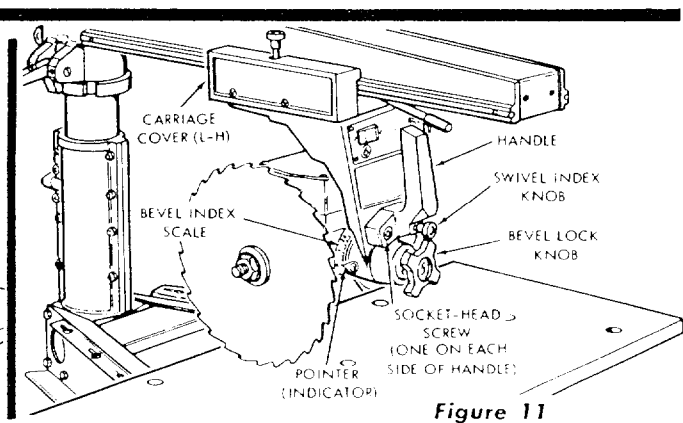

Figure 11

12. After preceding leveling operations are complete, move saw blade to the center of table to check for proper table height at points 5 and 6 (POSITION 5, figure 9). The table attaching screw at point 5 pulls table downward when tightened and the leveling screw at point 6 pushes table upward when tightened (provided screw at point 5 has been loosened). Thus, these two screws work against each other to adjust the center area of saw table. Both screws should be tight, however, when leveling has been completed.
13. Place the rip fence in vertical position behind the front table board.
14. Place the table spacer board behind the rip fence.
15. Place the rear table behind the table spacer board.
16. Install the table clamps at locations shown in figure 2 and tighten them firmly against the edge of rear table.

STEP FIVE—SQUARING THE SAW BLADE TO THE TABLE TOP

1. Place the edge of a framing square on the table top and against the saw blade as shown in figure 10.
2. When the saw blade is square to the table top, no light will be visible between the square and face of saw blade. Do not allow the square to rest against a tooth of the saw. If light is visible between the square and face of saw blade (with square leg held firm against the table top), perform the following adjustments.
 - a. Loosen the bevel lock knob just slightly and with a 5/16-inch Allen wrench loosen the two socket-head screws that secure the handle to the yoke. (See figure 11.) A screw is located at each side of the swivel index knob.
 - b. While holding the motor with one hand and the square with the other hand, tilt the motor until saw blade is square with table top. Then, while holding the square firmly against the saw blade and table top, tighten the bevel lock knob to hold motor and blade in position.
 - c. Move handle slightly toward left or right until swivel index pin is properly seated. Push firmly against swivel index knob (keeping swivel index pin seated) and tighten the two socket-head screws. The swivel index pin should slide freely in the handle.
- NOTE:** It may be necessary to perform more than one trial operation before the saw blade remains perfectly square with table top after tightening the screws.
- d. Recheck for blade squareness with table top.
- e. The indicators (pointers) should read 0° on the bevel scale. If not, loosen the indicator attaching screw, adjust indicators to zero and tighten the screws securely.

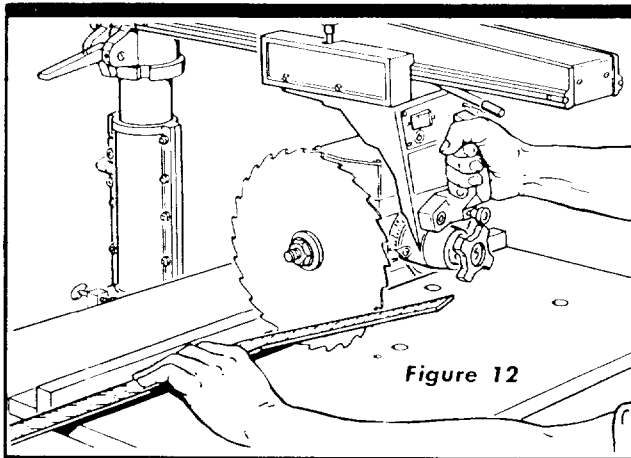

Figure 12

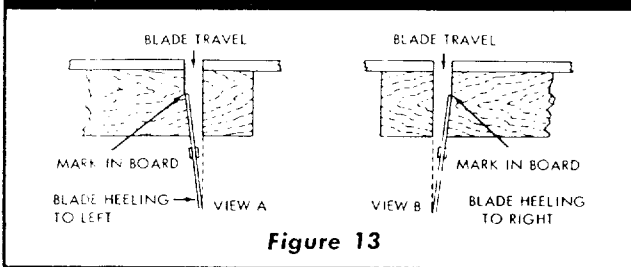

Figure 13

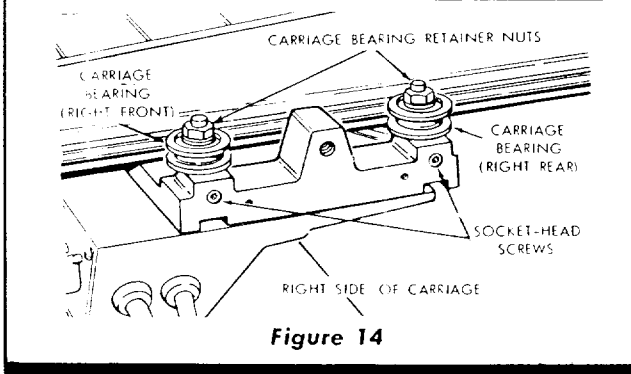
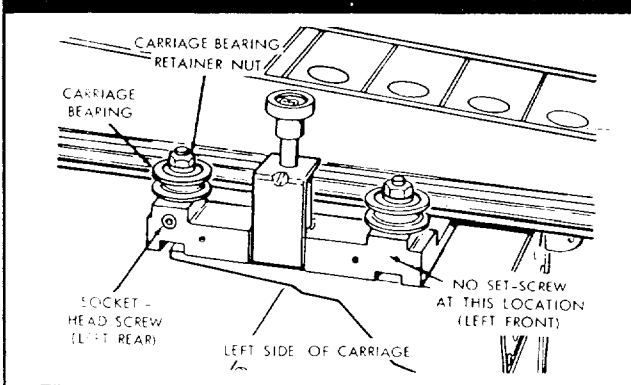

Figure 14

STEP SIX – CHECKING THE SAW BLADE FOR HEEL (LEFT AND RIGHT)

1. Place a square against the rip fence and the saw blade as shown in figure 12. The long leg of the square must be held firmly against the rip fence and the short leg must not touch any of the teeth on the saw blade.
2. If a gap exists between the saw blade and the square, one of two types of "heel" exists. The two types of "heel" are illustrated in views "A" and "B", figure 13. To correct for either type of "heel" condition, proceed as follows:
 - a. Remove the left-hand carriage cover by removing the two attaching screws.

- b. Remove the right-hand carriage cover by first removing the carriage lock knob (4, figure 1), by screwing it all the way out. Then remove the two attaching screws to free the cover.
- c. Loosen slightly the carriage bearing retainer nut just above the left rear carriage bearing. Then loosen slightly the corresponding nut over right rear carriage bearing.

NOTE: These nuts should be loosened just enough to permit the carriage bearing screws to slip in their holes.
- d. If the heel is in the direction shown in "View A" (figure 13), insert a 1/8-inch Allen wrench and loosen the set-screw at left rear position, then tighten set-screw at right rear the same amount. (See figure 14.)

NOTE: As one set screw is loosened, the opposite one should be tightened the same amount in order to retain the carriage bearing adjustment as accurately as possible.
- e. If the heel is in the direction shown in "View B" (figure 13), loosen the right rear set screw and tighten the left rear set-screw the same amount. (See figure 14.)
- f. After the heel has been corrected, tighten the rear carriage retainer nuts and check for proper tension of carriage bearings on the tracks.
- g. If front carriage bearings need adjusting for proper tension on the tracks, the adjustment is made on the right front carriage bearing. Loosen (slightly) the carriage bearing retainer nut and rotate the set screw until tension is correct. After the tension has been corrected, tighten the carriage bearing retainer nut. (The adjustment is correct when there is no side play between the arm and carriage, and the carriage moves forward and rearward with very slight resistance.)
- h. Install both carriage covers and carriage lock knob.

STEP SEVEN – DOUBLE CHECK SQUARING OF SAW

1. Recheck for correct adjustment of the saw by performing "STEPS ONE through SIX".
2. If the cross-cut travel is not perfectly squared, proceed with "STEP THREE" and make all adjustments listed in the "STEP THREE" procedure.

MAKING PRELIMINARY CROSS-CUT AT THE 0° POSITION

1. Attach saw guard assembly to the motor and tighten the guard clamp screw to secure the guard. (See figure 15.)
2. Pull motor forward of fence so that saw blade is free to rotate.
3. Lower the radial arm until saw blade just clears the table top.
4. Tighten carriage lock knob (4, figure 1).

CAUTION: Before cutting always be sure that the arm latch handle is fully engaged in detent notch.
5. Plug the power cord into receptacle.
6. Insert safety lock key, turn the key and press the switch to "ON" position. (See figure 19.)
7. Lower the radial arm until saw blade cuts into table top 1/32-inch deep. **THIS IS ALL THAT IS NECESSARY.**
8. To complete a blade clearance groove in the table and fence hold the handle with the left hand and loosen the carriage lock knob with the right hand. Slowly pull the motor with the left hand out to the extreme end of

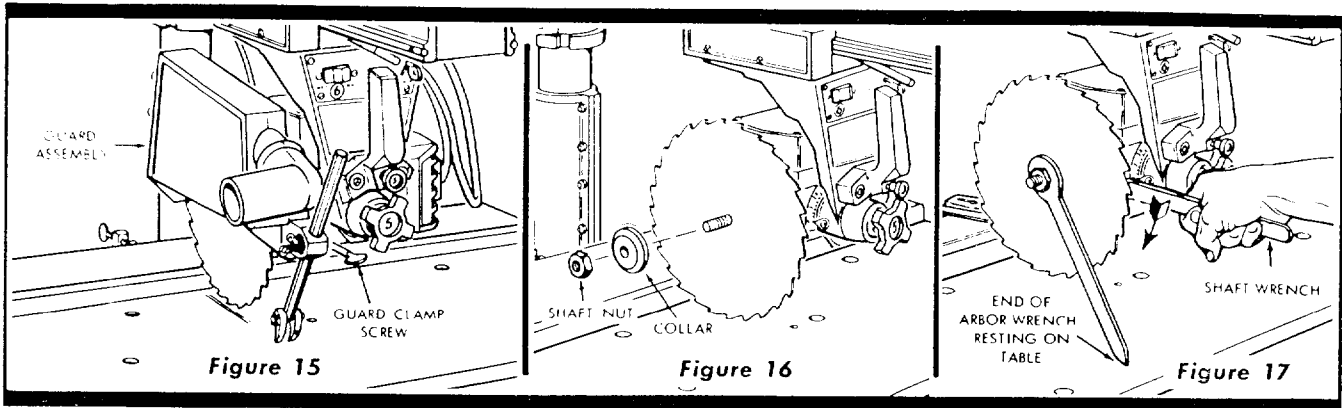

travel and then push the motor back through the fence to the extreme rear position. Push the switch to "OFF" position.

ATTACHING AND DETACHING THE SAW BLADE

1. Remove the shaft nut and one loose collar.
2. Place the saw blade on motor shaft making sure that saw blade teeth are in the same direction as shown in Figure 16.
3. Install loose collar and shaft nut.
4. Use the arbor wrench on motor shaft nut and the shaft wrench on hex tight collar on motor shaft to tighten the shaft nut. (See figure 17.)

OPERATING CONTROLS (See figure 18)

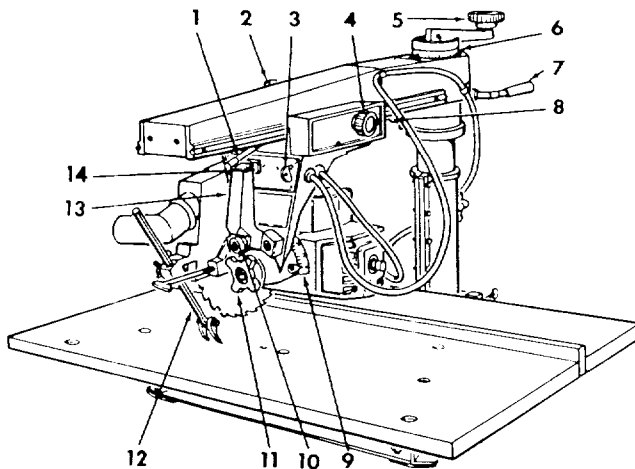

- | | |
|-----------------------|------------------------------|
| 1. Yoke clamp arm | 8. Arm latch handle |
| 2. Swivel index knob | 9. Bevel index scale |
| 3. Safety lock key | 10. Swivel index knob |
| 4. Carriage lock knob | 11. Bevel lock knob |
| 5. Elevation crank | 12. Anti-kickback pawl assy. |
| 6. Radial arm cap | 13. Handle |
| 7. Arm lock handle | 14. ON-OFF switch |

Figure 18

INSTRUCTIONS FOR USE OF KEY AND SWITCH

1. Insert the key into the slot and turn counterclockwise. (See figure 19.)
2. Press the ON-OFF switch toggle on the right end to start the saw motor. Press the left end of switch toggle to stop the saw.

NOTE: This saw can not be operated without the key, and likewise, the key can not be removed from the lock while the saw motor is running. This locking system was designed for safety and protection of the operator.

RAISING AND LOWERING THE RADIAL ARM is accomplished by the elevation crank (5, figure 18). One complete turn of this handle will raise or lower the radial arm 1/8-inch.

LOCKING THE CARRIAGE TO THE RADIAL ARM is accomplished by the carriage lock knob (4, figure 18). Turn the knob clockwise to lock; counterclockwise to unlock. Avoid excessive tightening of the knob.

ANGULAR MOVEMENT AND LOCKING THE RADIAL ARM are controlled by the arm lock handle (7, figure 18) and the arm latch handle (8). This handle is used to lock the arm to the column for normal cutting. It should also be used to eliminate any play between the arm and the column when levelling the table (Refer to STEP FOUR). This is done by tightening the arm lock handle until the arm is snug on the column, thus eliminating looseness and allowing the arm to rotate smoothly. The radial arm can be rotated 360° and locked in any desired position. The arm is unlocked by loosening the arm lock handle and raising the arm latch handle out of the detent notch. It is locked by tightening the arm lock handle. The radial arm has positive stops at 0° and 45°, left and right, and is released from these index positions by raising the arm latch handle.

In order to provide the most positive and accurate settings at the index positions, the following is recommended.

1. If the radial arm is already indexed, raise the arm latch handle, turn the arm lock handle (7, figure 18) ap-

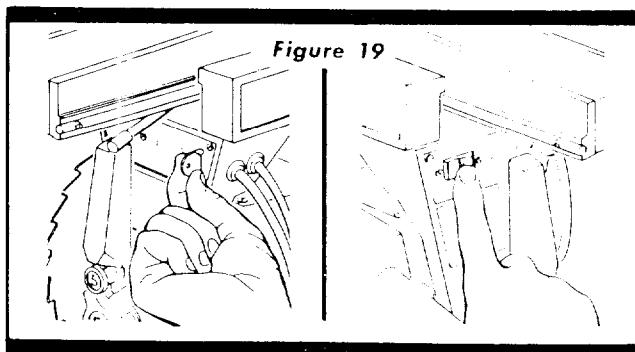

proximately 1/4 turn counterclockwise from the locked position and move the radial arm off the index position.

2. Move the radial arm into the index position (do not bump or jar) and depress the arm latch handle solidly into the detent notch with the palm of the hand.
3. Lock the radial arm by tightening the arm lock handle fully hand tight.

MOVEMENT AND POSITION OF THE MOTOR IN THE YOKE are controlled by the swivel index knob (10, figure 18) and bevel lock knob (11). The bevel index scale indicates the angular position of the motor with respect to the horizontal from 0° to 90°, in either vertical position. The swivel index knob indexes the motor at 0°, 45°, and 90°, up and down. Pull the knob out to release the motor from any of the index positions. At any other position, the swivel index knob is not engaged. The bevel lock knob locks the motor to yoke when the motor is in any position.

ADJUSTMENTS TO COMPENSATE FOR WEAR

Even though the finest materials and precision workmanship have been used to minimize wear, after long use it is reasonable to expect some wear. Adjustments have been built into the Craftsman saw to reduce or eliminate this wear.

REMOVING RADIAL ARM SIDE PLAY

1. Set the radial arm at 0° index position, making sure the arm latch handle is in the detent notch, and tighten the arm lock handle. (See figure 20.)
2. Apply side force with one hand on radial arm in both directions. If side play exists, an adjustment is required.

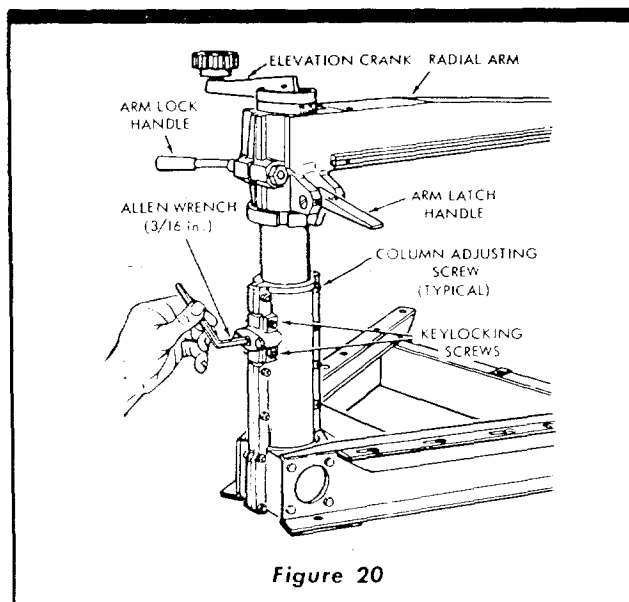

Figure 20

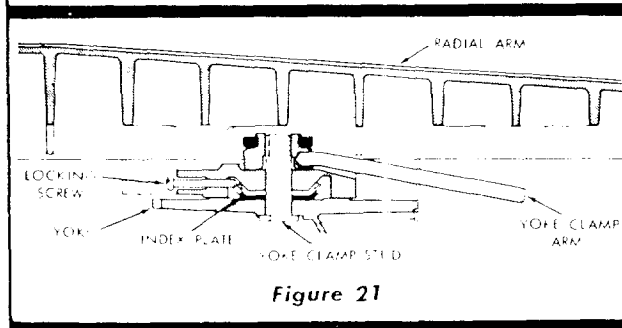

Figure 21

ROTATION AND POSITION OF THE YOKE are controlled by the swivel index knob (2, figure 18) and the yoke clamp arm (1). The swivel index knob automatically indexes the yoke at each 90° position and both 0° positions. Lift the knob to release it. The yoke clamp arm locks the yoke to the carriage in any position. Push the arm to the right to release it; push to the left to tighten. When "In-Ripping" it may be desirable to have more free table in front of the saw blade than is obtainable when the radial arm is at the 0° position. With the blade in the normal cross-cut position index the radial arm to 45° left and lock it. Then loosen the yoke clamp arm and position the yoke 45° clockwise. Secure the yoke clamp arm. The added free table space is now to the right of the blade and ripping should be done from the right side of the table. The reverse is also true for "Out-Ripping" by indexing the radial arm 45° right and positioning the yoke 45° counterclockwise. The added table space is now to the left of the blade and ripping should be done from the left side of the table.

3. Loosen two locking screws, insert a 3/16-inch Allen wrench into the socket-head set-screw that adjusts the column tube wedge key, as shown in figure 20. Rotate the set-screw slowly in (clockwise) until no side play can be felt in radial arm.
4. Check for binding by rotating the elevation crank. If the crank rotates with noticeable resistance, loosen the set-screw by rotating the Allen wrench counterclockwise until rotation is normal. An effective method for finalizing the set-screw adjustment is to rotate the screw while the elevation crank is being rotated, checking for side play in radial arm as the adjustment progresses. The adjustment is correct when all side play of radial arm is eliminated and only very slight additional resistance can be felt when rotating the elevation crank.
5. If some radial arm side play can still be detected after performing the above adjustment, it will be necessary to adjust the forward five screws through the right, and left-hand column supports as follows:
 - a. While rotating the elevation crank, tighten the five column adjusting screws slightly at the forward edge of column supports. Each screw should be tightened only slightly, and each one the same amount, until a slight resistance can be felt when rotating the elevation crank, then each screw backed off just enough to restore a normal feel to the elevation crank.
 - b. Recheck the adjustment of the column tube wedge key set-screw as outlined in preceding instructions.
6. After all adjustments have been completed recheck the radial arm for absence of side play.
7. When side play is eliminated, tighten the column key locking screws.

YOKE CLAMP ARM ADJUSTMENT

The normal locking position of the yoke clamp arm (1, figure 18) is parallel with the radial arm. An adjustment will seldom be necessary, however, it may be accomplished as follows:

1. Loosen the carriage lock knob (4, figure 18), move the carriage out to the forward end of radial arm and tighten carriage lock knob.
2. Locate the index plate locking screw at the rear of the yoke assembly. (See figure 21.)
3. Turn the locking screw outward at least 1/4-inch from tight position. This frees the index plate (figure 21) which

is keyed to the yoke clamp stud, thus permitting the stud to be rotated when the yoke clamp arm is loosened.

4. Loosen the yoke clamp arm, and with screwdriver or arbor wrench, rotate the yoke clamp stud a small fraction of a turn (clockwise when viewed from bottom), then tighten the yoke clamp arm.
5. If the yoke clamp arm still does not line up parallel to the radial arm, loosen it and again move the yoke clamp stud. Continue this operation until the yoke clamp arm is properly aligned when tightened.
6. Rotate the locking screw back into position to secure the adjustment by preventing movement of index plate.

NOTE: It may be necessary to loosen the yoke clamp arm so that end of locking screw can enter a notch of the index plate. This would alter the arm adjustment slightly but not enough to be of any consequence.

CARRIAGE

To test for looseness in the carriage, firmly grasp the carriage across the two carriage covers and apply a firm

rocking motion. Noticeable looseness may be adjusted as follows:

1. Remove the saw guard and blade.
2. Place a block of wood on saw table under the motor and turn elevation crank until just the weight of motor rests on the block.
3. Remove the right hand carriage cover by removing the carriage lock knob and two attaching screws.
4. Loosen carriage bearing retainer nuts one or two turns. (See figure 14.)
5. Using a 1/8-inch Allen wrench, rotate the two socket-head set-screws inward (clockwise) a fraction of a turn.

NOTE: If all carriage side play is removed by tightening the set-screws, when the carriage bearing retainer nuts are tightened, the carriage bearings may bind on the track. This adjustment should be made, by alternately adjusting the set-screws and carriage bearing retainer nuts, until all side play is removed and the carriage moves with only very slight resistance.

6. Install right-hand carriage cover and carriage lock knob.

PROPER OPERATING PROCEDURES

SET-UP GUIDE

A combined number and color code system, designated as a "SET-UP GUIDE", has been applied to the saw in order to simplify the location of controls required for a particular set-up operation. The "SET-UP GUIDE" is both a convenience and safety measure, particularly for inexperienced operators. The operator should become familiar with this feature before operating the saw. A brief explanation of the "SET-UP GUIDE" is as follows: (See figure 22.)

1. Notice the radial arm trim strip, the forward end of which contains six diagrams numbered "1" through "6". Each number is in a colored circle, and a corresponding number in an identical colored circle will be on the particular operating control member involved.
2. Locate each control as follows:
 - a. "DEPTH OF CUT". Diagram shows the elevation crank which is used to raise and lower the blade. The numeral "1" in a blue circle is on the crank handle.
 - b. "ANGLE OF CUT". Two levers are involved in releasing, securing and indexing the angle of radial arm. These are: arm lock handle and arm latch handle, each marked with the numeral "2" in a purple circle.
 - c. "CARRIAGE PIVOT". Two controls are used in this operation. They are: swivel index knob and yoke clamp arm, each marked with the numeral "3" in an orange circle.
 - d. "CARRIAGE LOCK". The carriage lock knob is rotated clockwise to secure the carriage on radial arm, and counterclockwise to release it. The numeral "4" in a green circle is at the center of the knob.
 - e. "BLADE ANGLE". The two controls used in angular positioning and indexing of the motor to provide the desired saw blade angle are: bevel lock knob and swivel index knob. The numeral "5" in a yellow circle is attached to each of these controls.
 - f. "POWER SWITCH". This switch is located in the upper left area of the carriage and has the numeral "6" in a red circle directly under it.

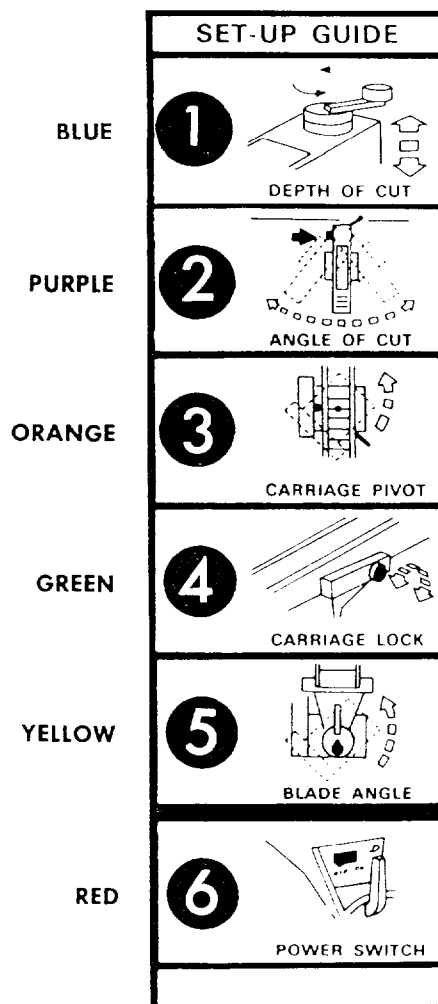

Figure 22

SAFETY INSTRUCTIONS

Safety is a combination of common sense and alertness at all times when the saw is being used.

WARNING: Do not allow familiarity that comes from frequent use of the saw to become commonplace. Always remember that a careless fraction of a second is sufficient to inflict severe injury.

1. **DRESS PROPERLY.** Operation of the saw is simple, safe and easy — when properly accomplished. Always be alert. Do not wear a tie or other loose articles. Keep

long sleeves down with cuffs fastened, or wear short sleeves. **NEVER STOP BEING CAREFUL.** One moment of inattention can produce a painful injury.

2. **AVOID AWKWARD HAND POSITIONS.** Do not allow hands to assume a position in which a sudden slip can cause them to move into the saw blade.
3. **NEVER TWIST WORK.** Twisting the work piece will bind the blade and produce a "kickback".

SAFETY PRECAUTION — The motor shaft has a cap threaded onto the unused end of motor shaft and should not be removed.

LUBRICATION

This Craftsman saw is a fine machine and should be given the best of care. If kept clean and properly lubricated, it will give many years of trouble-free service. Before describing the various points which may periodically require lubrication, IT IS MORE IMPORTANT TO FIRST MENTION THE VARIOUS SPOTS WHICH SHOULD NOT BE LUBRICATED.

NO LUBRICATION REQUIRED AT THESE POINTS

- Do not lubricate any ball races or ball bearings.
- Do not lubricate the motor bearings. These are sealed ball bearings and require no added lubrication.
- Do not lubricate carriage bearings or tracks.

PERIODICALLY LUBRICATE THESE POINTS

Use SAE No. 10-30 auto engine oil and refer to Parts List for locations.

1. Apply a few drops of oil along the swivel index pin only if the pin has a tendency to stick. Remove the left-hand carriage cover and use oil sparingly to prevent it from getting on the ball bearings or races.
2. A light film of oil can be wiped on the face of the column tube and keyway to lubricate the fit between this part and the key and column support.
3. An oil hole is provided in the top of elevation crank to facilitate lubrication of the elevation shaft and radial arm cap bearing surface.
4. The threads on elevation shaft are lubricated by removing the elevation crank and radial arm cap.

STANDARD SAW OPERATIONS

CROSS-CUTTING

Cross-cutting is the sawing of wood across the grain. Boards are sawed with the grain running the length of the board. If a straight cross-cut is desired, the board is placed on the saw table against the fence so that the grain is parallel to the fence. (See figure 23.)

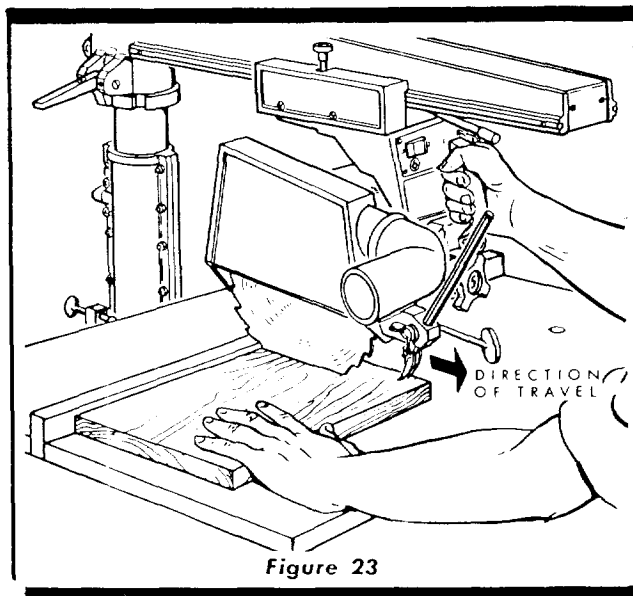

Figure 23

NOTE: When cross-cutting normal pieces of lumber, the long end of the board should be placed to the left of the saw blade, as the board is normally held by the left hand during the sawing operation.

1. The radial arm must be positioned at 0° as indicated by the radial arm position indicator. The arm latch handle must be indexed and arm lock handle tightened. (Refer to paragraph entitled "Angular Movement and Locking of the Radial Arm".)
2. The yoke must be indexed at the 0° position, making the saw blade perpendicular to the rip fence, and the yoke clamp arm placed in locked position.
3. The motor must be positioned at 0°, as indicated by the bevel scale, and locked.
4. Turn the elevation crank to lower the saw until the blade teeth are approximately 1/32" below the table surface and ride in the saw slot made when performing the "PRELIMINARY CROSS-CUT AT THE 0° POSITION".
5. Push the saw carriage to the rear of the radial arm so the blade is behind the rip fence.
6. Adjust the saw guard so the bottom is parallel to the table and set the anti-kickback pawl assembly so it clears the board to be cut.
7. Turn the switch key "ON" and press the switch to start the saw motor.

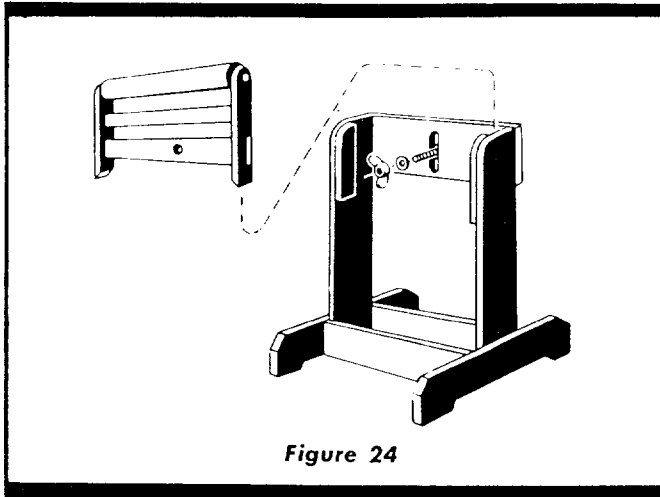

Figure 24

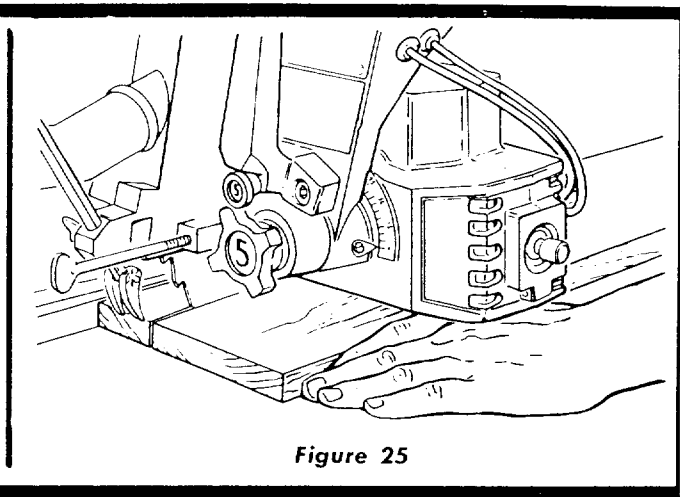

Figure 25

8. Hold the board firmly against the rip fence with the left hand and grasp the handle with the right hand.
9. The cut is then made by pulling the carriage forward until saw blade cuts through the work. When the cut is complete, the saw should be returned to the back of the radial arm and the switch turned "OFF". **When more experience is gained by using the saw, it will be noticed that when pulling the saw forward during cross-cutting, the saw blade tends to feed itself through the work due to the rotation of the blade and the direction of feed. Therefore, the operator should develop the habit of holding his right arm straight from the shoulder to the wrist.** After using this method a few times, the operator will find that it is necessary to roll or rotate the body from the waist up. It will soon become apparent that very little effort is required to move the saw blade through the work, and in most cases, the right arm is used merely to control the rate of feed. It will also be discovered that when cross-cutting a thick board, movement of the saw through the work must be retarded. By holding the right arm (right hand normally grips the saw handle) straight, the operator can easily control the rate of feed, thus preventing the saw blade from overfeeding and stalling the saw motor, which must be avoided whenever possible. In some cases it may become necessary to cross-cut boards that extend over the saw table on one, or both sides. This can buckle the board and bind the saw during the cut. To eliminate this condition the ends of the board should be supported. Figure 24 shows a typical support that can be easily constructed to facilitate cross-cutting of long boards.

RIPPING

Ripping is sawing wood with the grain. It is always done with the help of the fence as a guide to position the board and produce the desired width of cut. Since the work is pushed along the fence, it must have a reasonably straight edge in order to make sliding contact with the fence. Also, the work must make solid contact with the table to prevent "wobble" or "rock". A straight edge should be provided, even if it means temporary nailing of an auxiliary straight-edge board to the work. If the work piece is warped, turn the hollow side downward on the saw table.

The saw guard and anti-kickback pawl assembly should always be used in ripping operations. Before ripping, and after the saw has been positioned prior to sawing, the saw guard and anti-kickback pawl assembly must be properly adjusted. Loosen the guard clamp screw and lower the nose of the guard to within 1/8-inch above the top surface

of the board to be cut, and tighten the guard clamp screw securely.

CAUTION: The nose of the guard refers to that end of the guard which is opposite to the end which mounts the anti-kickback pawl assembly. Always rip from the nose of the guard. See Warning Label on guard.

At the opposite end of the guard, loosen the wing screw holding the anti-kickback pawl assembly and lower the assembly until the tips of the pawls are 1/8-inch below the top surface of the board to be cut and tighten the wing screw securely.

IN-RIPPING. "In-rip" refers to a position when the saw blade is between the motor and fence, parallel to the fence. (See figure 25.) To place the saw in this position, unlock the yoke, disengage the swivel index knob and rotate the yoke 90° clockwise (viewing it from the carriage) until the swivel latch pin automatically indexes the yoke at 90°. Lock the yoke securely. Position the carriage on radial arm to provide proper width of cut by measuring from edge of saw blade to rip fence with a scale. Position the discharge elbow on the guard so that sawdust will be blown toward the rear. Turn the saw "ON" and lower the radial arm until saw blade cuts into the table top approximately 1/32-inch and turn the saw "OFF". Adjust the saw guard and anti-kickback pawl assembly as described previously.

The board must be fed into the saw blade from the right side of the table. Therefore, the normal position for the operator is at the right side of table. With the left hand, safely clear of the blade and holding the board down against the table and rearward against the fence, use the right hand to feed the board into the saw. The left hand should remain stationary, serving as a guide only. As the right hand approaches the left hand, use a push stick in the right hand to complete the cut. Do not leave a long board unsupported so that the spring of the board causes it to shift on the table. (See figure 24.)

OUT-RIPPING. "Out-rip" refers to a position when the motor is between the blade and the fence. Normally, this position is used only when the width of the required ripped board cannot be cut from the in-rip position. To place the saw in the "out-rip" position, the yoke must be rotated and indexed 90° counterclockwise from the cross-cut position and locked. The same procedure for pre-setting the table top (see "In-Ripping") and adjusting the saw guard and anti-kickback pawl assembly (see "Ripping") should be followed. The same procedure for sawing is used except that now the operator stands at the left side of the table and a push stick is normally not required.

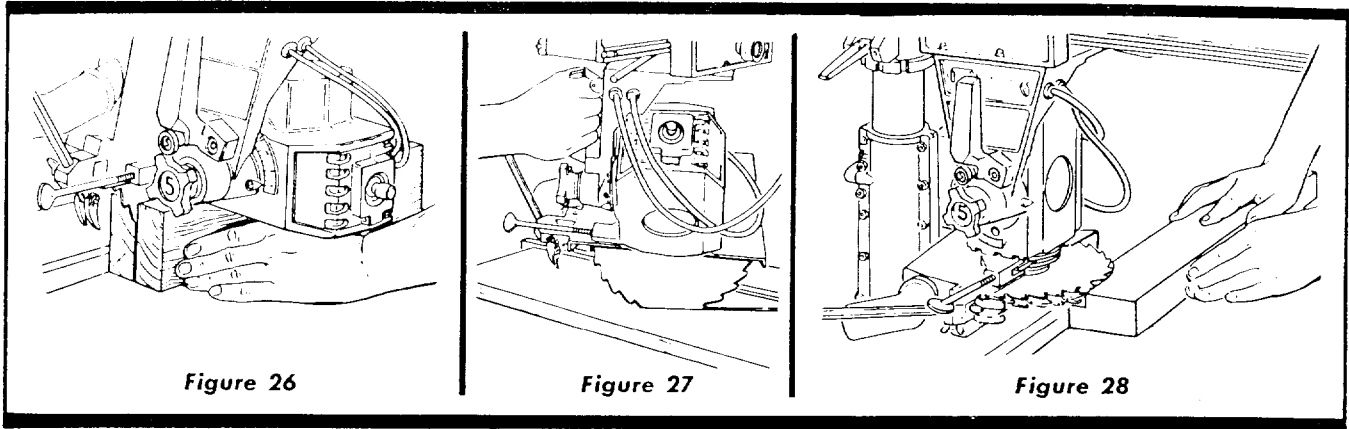

Figure 26

Figure 27

Figure 28

RESAWING

Resawing is cutting thick boards into thinner ones. It is actually a ripping operation. (See figure 26.) Small boards up to 2-inches maximum width can be resawed in one pass. Larger boards up to 4-inches maximum width require two passes, one along each edge of the board. When two cuts from opposite edges are required, they should overlap 1/2-inch from the approximate center of the board. If the first cut is too deep, the kerf will close and bind the saw on the second cut, with some danger of "kickback". Also, when the kerf closes, the two sides of the cut are no longer parallel to the saw blade, and the saw will cut into them and spoil accuracy and appearance. Keep the same face of the board against the fence when making both cuts.

When cutting boards thicker than 3-1/2 inches, a fence should be used which extends 3-inches above the table top. When cutting boards thicker than 4-1/2-inches, cut both sides and finish the cut with a hand saw.

BEVEL AND MITER CUTS

Bevel cuts can be made from either a cross-cutting or ripping position by tilting the blade to the desired angle. Miter cuts can be made only from a cross-cutting position when the blade and radial arm are at some angle other than 90° to the fence. A bevel miter cut is a cut which is both beveled and mitered. This cut is made with the blade and radial arm set at the desired miter angle to the fence, then the blade (only) is tilted, with respect to the table top, to the desired bevel angle. This cut is usually referred to as a compound miter. (See figure 27.)

USE OF THE DADO HEAD

The dado saw (or head) is a special set of blades for cutting grooves and dados. The Craftsman 8-inch Kromedge Dado Set may be purchased at any Sears Retail Store or Catalog Order House. The complete head consists of two outside blades 1/8-inch thick, six chipper blades 1/8-inch thick and paper washers for 1/16-inch width adjustments. With these blades, grooves may be made in widths of 1/8-inch, 1/4-inch, and additional widths in steps increased by 1/16-inch each, up to a maximum of 13/16-inch. Outside blades may be used alone, but chippers cannot be used alone. When the maximum 13/16-inch width of dado is used on the motor shaft, the outside loose collar must not be used. The width of the dado can be reduced while using the loose collar and two or more passes may be made with the work to obtain the desired width of cut. Whenever two or more chippers are used, the cutting ends should be staggered as evenly as possible around the circumference. Fractional adjustments in thickness of the head can be made by using paper washers between the outside blades and chippers.

Dado head operations are essentially the same as those operations using a standard saw blade—but the dado head takes a bigger bite, therefore, the work-piece should be held more firmly. When a groove wider than the dado head is needed, make two or more passes, with cuts spaced to overlap a trifle. Dado work is performed in the cross-cut position. Ploughing is done in the ripping position. If the rip or plough position is used, the saw guard and anti-kickback pawl assembly should be adjusted as described in the paragraph "RIPPING". Rabbeting is done with the motor shaft in a vertical position. (See figure 28.) When rabbeting, the motor is indexed 90° to the vertical position so the blades are between the table top and motor, and the yoke is indexed 90° clockwise and locked. The saw is moved back on the radial arm and locked to the arm when the amount of the blade extending forward of the fence is equal to the depth of the rabbet desired. If the depth of the rabbet is large, do not attempt to cut it in one operation. Lower the radial arm until blades are in a position to cut the desired width of rabbet in the edge of the board. The bottom of the saw guard should be parallel to the fence and the discharge elbow directed to the rear of the saw.

MOLDING OR SHAPING

This work is performed with Craftsman Molding Cutter Heads, and a set of cutters depending on the type of molding cut desired. The saw is positioned in the same manner as that described for rabbeting. (See figure 29.) Since the position of the cutters can be adjusted with respect to the fence and table top, any or all of the cutter shapes may be used.

The Molding Cutter Guard should be used with Molding Cutter Head.

ROUTING AND DOVETAILING

Routing and dovetailing are accomplished with the motor indexed and locked 90° from horizontal, except that this time the externally threaded stub end (opposite the normal blade end) is between the motor and table top. The following chucks will mate, with this external 1/2-20 thread. (See figure 30.)

- 0-inch to 1/4-inch Chuck
- 5/64-inch to 1/2-inch Key Chuck

The following routers and dovetails are recommended:

- | | |
|-----------------|-------------------|
| 1/8-inch router | 3/8-inch dovetail |
| 1/4-inch router | 1/2-inch dovetail |
| 3/8-inch router | |
| 1/2-inch router | |
| 5/8-inch router | |

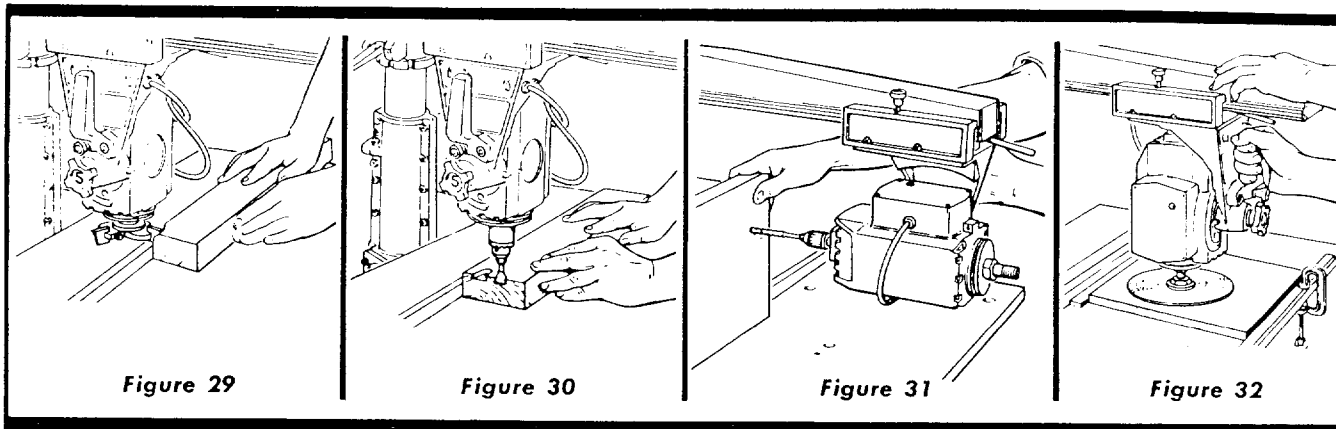

Figure 29

Figure 30

Figure 31

Figure 32

Routing may be performed by either moving the work with a stationary router, or by clamping the work to the table and moving the router. Always approach the router bit from the left-hand side of the saw.

BORING

The saw may be converted to a horizontal drill for boring by using one of the recommended chucks and proper drill. For drilling holes on an angle, the radial arm should be positioned to the desired angle while the work is parallel to the fence. (See figure 31.)

SANDING

Using the 10-inch sanding disc, mounted on the saw end of the motor, the saw may be converted into a sander that will operate in any position. The loose collars should be used on both sides of the sanding disc.

STABILIZING WASHERS FOR THIN BLADES

Stabilizing washers should be used with blades for improved appearance of the finish cuts.

HELPFUL HINTS

1. The life of the composition saw table may be greatly lengthened if a 1/4-inch piece of plywood is tacked to the table top after leveling. Then all cutting would be done in the added piece of plywood instead of the table top.
2. There is a possibility that during (or after) shipment, the wood front table; spacer board; or rear table might become slightly warped. Lay a straight-edge across the surface of the table and check for gaps or high spots on the table. Any portions of the table that are not flat should be planed and sanded until flat. Sanding can be done by using one of the two key chucks referred to under "ROUTING" and a Craftsman moulded rubber 6-inch sanding disc.

3. When sanding the table top or routing with the work stationary, the arm latch handle may be prevented from automatically indexing by raising it to the vertical position. (See figure 32.)
4. A scale may be attached to the fence to aid the operator when measuring lengths during cross-cut operations. This is accomplished by tacking a yard stick to the fence as shown. (See figure 33.)
5. In the event the fence is warped and cannot be straightened by tightening the table clamps, proceed as follows:
 - a. Remove the fence and replace it with a temporary fence made from a straight piece of scrap lumber. Proceed to cut slots in the original fence where the gap between the fence and front table was determined to be the greatest. (See figure 34 for slotting arrangement.)
 - b. Replace the fence (after slotting) behind the front table with the slots toward the rear and tighten the table clamps.
6. There are three positions in which the fence can be located. (See figure 35.)
 - a. Normal position (1, figure 35).
 - b. Position used for maximum cross-cut on 1-inch material and for greater bevel and miter capacity (2, figure 35).
 - c. Position used for maximum "out-rip" capacity (3, figure 35).
7. Keep all cutting tools, such as saw blades, drills, molding cutters, dados, etc., sharp, and do not "force feed" work enough to drastically reduce motor speed.
8. When using planer, molding, or dado blades, repeated light cuts will produce best results. Deep cuts reduce the quality of the finish and often produce "tear-outs".

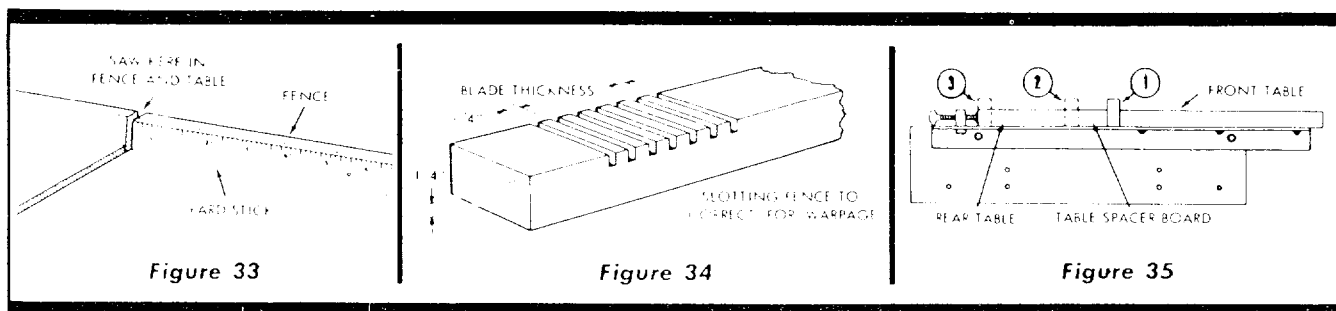
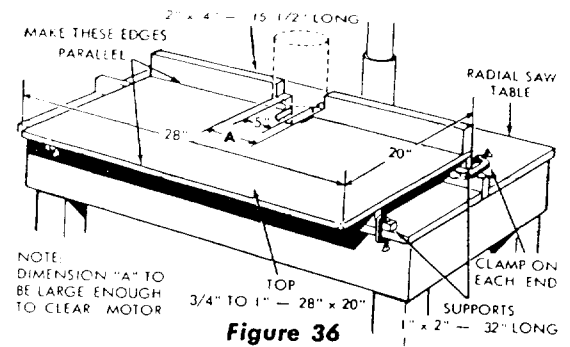

Figure 33

Figure 34

Figure 35

9. An auxiliary table top for molding or shaping may be constructed similar to the one shown in figure 36. Notice the shape of the back guide fence which has a cut-out 5-inches wide at the center to provide adequate clearance for the molding head and cutters. Also, a wider clearance (marked "A") should be cut out to allow for the saw motor. Make sure the front edge of the auxiliary table is parallel with the forward surface of the guide fence. The auxiliary table top can be attached to a work bench with "C" clamps.



**FOR TROUBLE SHOOTING CHARTS
SEE PAGES 16 AND 17**

**FOR PARTS LISTS
SEE PAGES 18 TO 23**

TROUBLE SHOOTING CHART

| TROUBLE | PROBABLE CAUSE | REMEDY |
|--|---|--|
| Blade "heels" to right or left. | 1. Heel has not been taken out of blade. | 1. Refer to "STEP SIX – CHECKING THE SAW BLADE FOR HEEL (Left and Right)." |
| Cannot "rip" properly, wood smokes and motor stops. | 1. Dull blade. 2. Crosscut travel and rip fence are not squared. 3. Radial arm not locked in 0° position. 4. Blade not squared to the table top. | 1. Check for sharpness of blade or warped board. Refer to the paragraph entitled "RIPPING." Ripping with hollow-ground blades when boards are badly warped is very difficult. 2. Refer to "STEP THREE – SQUARING THE CROSS-CUT TRAVEL." 3. Make sure the radial arm is locked and indexed properly in the 0° position. 4. Refer to "STEP FIVE – SQUARING THE SAW BLADE TO THE TABLE TOP." |
| Elevation crank operates roughly; chatter exists. | Column tube key not adjusted properly. | Check adjustment of key plug. Refer to "STEP TWO – ELIMINATING RADIAL ARM SIDE PLAY." |
| Motor will not run. | 1. Protector open; circuit broken. 2. Low voltage. | 1. Reset protector by pushing in on red button, located on top of motor junction box. 2. Check power line for proper voltage. |
| Motor will not run and fuses "BLOW." | 1. Short circuit in line cord or plug. 2. Short circuit in motor terminal box or loose connections. | 1. Inspect line cord and plug for damaged insulation and shorted wires. 2. Inspect all terminals in motor terminal box for loose or shorted terminals. |
| Blade does not maintain constant depth of cut across table. | 1. Plane of table top not parallel to horizontal plane through radial arm. 2. Table badly warped. | 1. Table is not aligned with radial arm. Refer to "STEP FOUR – ADJUSTING THE TABLE PARALLEL TO RADIAL ARM." 2. Replace table top. |
| Blade does not cut squarely, or repeat cuts cannot be secured. | 1. Excessive free play in column tube key adjustment. 2. Excessive free play in radial arm. 3. Crosscut travel and rip fence are not squared. 4. Improper movement of arm for miter cuts. 5. Saw blade not square to the table top. 6. Bearings loose on track. 7. Yoke does not index properly. 8. Yoke clamp does not tighten yoke; or looseness is felt in yoke assembly. | 1. Refer to "STEP TWO – ELIMINATING RADIAL ARM SIDE PLAY." 2. Eliminate looseness in arm latch screws. 3. Refer to "STEP THREE – SQUARING THE CROSS-CUT TRAVEL." 4. Adjust arm latch handle for correct indexing at 90° which will produce a correct 45° setting. Refer to "STEP THREE – SQUARING THE CROSS-CUT TRAVEL." 5. Refer to "STEP FIVE – SQUARING THE SAW BLADE TO THE TABLE TOP." 6. Refer to paragraph entitled "CARRIAGE," under "ADJUSTMENTS TO COMPENSATE FOR WEAR." 7. Check to see that yoke indexes properly and that carriage bearings are not loose on tracks. Refer to "STEP SIX – CHECKING THE SAW BLADE FOR HEEL." 8. Refer to paragraph entitled "YOKE CLAMP ARM ADJUSTMENT" under "ADJUSTMENTS TO COMPENSATE FOR WEAR." |

TROUBLE SHOOTING CHART – MOTOR

NOTE: Motors used on wood-working tools are particularly susceptible to the accumulation of sawdust and wood chips and should be blown out or "vacuumed" frequently to prevent interference with normal motor ventilation.

| TROUBLE | PROBABLE CAUSE | REMEDY |
|---|--|--|
| Motor will not run. | <ol style="list-style-type: none"> 1. Protector open; circuit broken. 2. Low voltage. | <ol style="list-style-type: none"> 1. Reset protector by pushing in on red button, located on top of motor junction box (indicated by audible click). 2. Check power line for proper voltage. |
| Motor will not run and fuses "BLOW." | <ol style="list-style-type: none"> 1. Short circuit in line cord or plug. 2. Short circuit in motor terminal box or loose connections. | <ol style="list-style-type: none"> 1. Inspect line cord and plug for damaged insulation and shorted wires. 2. Inspect all terminals in motor terminal box for loose or shorted terminals. |
| Motor fails to develop full power. (Power output of motor decreases rapidly with decrease in voltage at motor terminals.) For example: a reduction of 10% in voltage causes a reduction of 19% in maximum power output of which the motor is capable, while a reduction of 20% in voltage causes a reduction of 36% in maximum power output. | <ol style="list-style-type: none"> 1. Power line overloaded with lights, appliances and other motors. 2. Undersize wires or circuit too long. 3. General overloading of power company's facilities. (In many sections of the country, demand for electrical power exceeds the capacity of existing generating and distribution systems.) 4. Incorrect fuses in power line. | <ol style="list-style-type: none"> 1. Reduce line load. 2. Increase wire sizes, or reduce length of wiring. 3. Request a voltage check from the power company. 4. Install correct fuses. |
| Motor starts slowly or fails to come up to full speed. | <ol style="list-style-type: none"> 1. Low voltage – will not trip relay. 2. Starting relay not operating. | <ol style="list-style-type: none"> 1. Correct low voltage condition. 2. Replace relay. |
| Motor overheats. | <ol style="list-style-type: none"> 1. Motor overloaded. 2. Improper cooling. (Air circulation restricted through motor due to sawdust, etc.) | <ol style="list-style-type: none"> 1. Correct overload condition. 2. Clean out sawdust to provide normal air circulation through motor. |
| Starting relay in motor will not operate. | <ol style="list-style-type: none"> 1. Burned relay contacts (due to extended hold-in periods caused by low line voltage, etc.) 2. Open relay coil. 3. Loose or broken connections in motor terminal box. | <ol style="list-style-type: none"> 1. Replace relay and check line voltage. 2. Replace relay. 3. Check and repair wiring. |
| Motor stalls resulting in blown fuses or tripped circuit breakers). | <ol style="list-style-type: none"> 1. Starting relay not operating. 2. Voltage too low to permit motor to reach operating speed. 3. Fuses or circuit breakers do not have sufficient capacity. | <ol style="list-style-type: none"> 1. Replace relay. 2. Correct the low line voltage condition. 3. Replace fuses or circuit breakers with proper capacity units. |
| Frequent opening of fuses or circuit breakers. | <ol style="list-style-type: none"> 1. Motor overloaded. 2. Fuses or circuit breakers do not have sufficient capacity. 3. Starting relay not operating (motor does not reach normal speed.) | <ol style="list-style-type: none"> 1. Reduce motor load. 2. Replace fuses or circuit breakers. 3. Replace relay. |

PARTS LIST

CRAFTSMAN, 9-INCH RADIAL SAW, MODEL No. 113.29350

All parts illustrated in Figures 37 through 40 and listed under part numbers may be ordered through any Sears retail mail order store. Order parts by mail from the catalog order store which serves the territory in which you live. In several instances, part numbers are listed for COMPLETE ASSEMBLIES. All parts are shipped prepaid within the limits of the continental United States.

WHEN ORDERING REPAIR PARTS, ALWAYS GIVE THE FOLLOWING INFORMATION AS SHOWN ON THIS LIST:

1. THE PART NUMBER
2. THE PART NAME
3. THE MODEL NUMBER 113.29350
4. THE NAME OF ITEM — RADIAL SAW

Always order by Part Number — not by Key Number

FIGURE 37 PARTS LIST

| Key No. | Part No. | Description |
|---------|----------|--|
| 1 | 9404365 | *Screw, No. 8-32 x 5/16, Type 23C1, Pan Hd. Slotted, Steel |
| 2 | 63032 | Trim, Radial Arm |
| 3 | 191230 | *Screw, Mach., 1/4-28 x 1, Fill. Hd. Slotted, Steel |
| 4 | 115109 | *Washer, Med. Lock 1/4 S.A.E. Steel |
| 5 | 63038 | Washer, Arm Clamp |
| 6 | 60059 | Handle, Arm Lock |
| 7 | 63033 | Arm, Radial |
| 8 | 30613 | Clamp, No. 2 Cord |
| 9 | 448011 | *Screw, No. 8-32 x 3/8, Type 23C1, Pan Hd. Slotted, Steel |
| 10 | 63035 | Screw, Arm Latch |
| 11 | 116120 | Washer, Split Lock 5/16 x .125 x .078, Steel |
| 12 | 60053 | *Screw, 5/16-18 x 1/2, Hex. Socket Hd. Cap, Plain |
| 13 | 37435 | *Wrench, Hex. "L", 1/4 Across Flats |
| 14 | 63034 | Track |
| 15 | 448907 | *Screw, No. 6-32 x 5/8, Type 23C1, Fill. Hd. Slotted, Cad. Pl. Steel |
| 16 | 3540 | Wrench, Arbor |
| 17 | 30495 | Nut, Shaft |
| 18 | 63017 | Collar, Saw Blade |

| Key No. | Part No. | Description |
|---------|----------|---|
| 19 | 60169 | Blade, Saw, 9" |
| 20 | 63062 | Wrench, Shaft |
| 21 | 37861 | Key, Safety Lock |
| 26 | 60030 | Washer, .505 x 1 x 1/32, Steel |
| 27 | 63037 | Plug |
| 28 | 222405 | *Screw, Set, 1/2-20 x 3/8, Hex. Socket Hd., Flat Pt., Blk. Oxide |
| 29 | 30505 | *Wrench, Hex "L", 1/8 Across Flats |
| 30 | 63036 | Latch, Arm |
| 31 | 63070 | Disk, Color (2) |
| 32 | 118647 | *Nut, Hex. Jam, 1/2-13 x 3/4 x 5/16 |
| 33 | 63002 | Cap, Radial Arm |
| 35 | 453676 | Pin, Roll |
| 36 | 63053 | Washer, Knob |
| 37 | 63052 | Shaft, Crank Knob |
| 38 | 63051 | Knob, Elevation Crank |
| 39 | 63069 | Disk, Color (1) |
| 40 | 63054 | Ring, Retaining |
| 42 | 9404351 | Screw, No. 6-32 x 5/16, Type 23C1, Pan Hd. Slotted, Cad. Pl. Steel |
| 43 | 63183 | Cap Assembly, Radial Arm |
| None | 63152 | Operating Instructions and Parts List for Craftsman 9" Radial Arm Saw Model 113.29350 |

* Standard Hardware Item — May be Purchased Locally.

CRAFTSMAN, 9-INCH RADIAL SAW, MODEL No. 113.29350

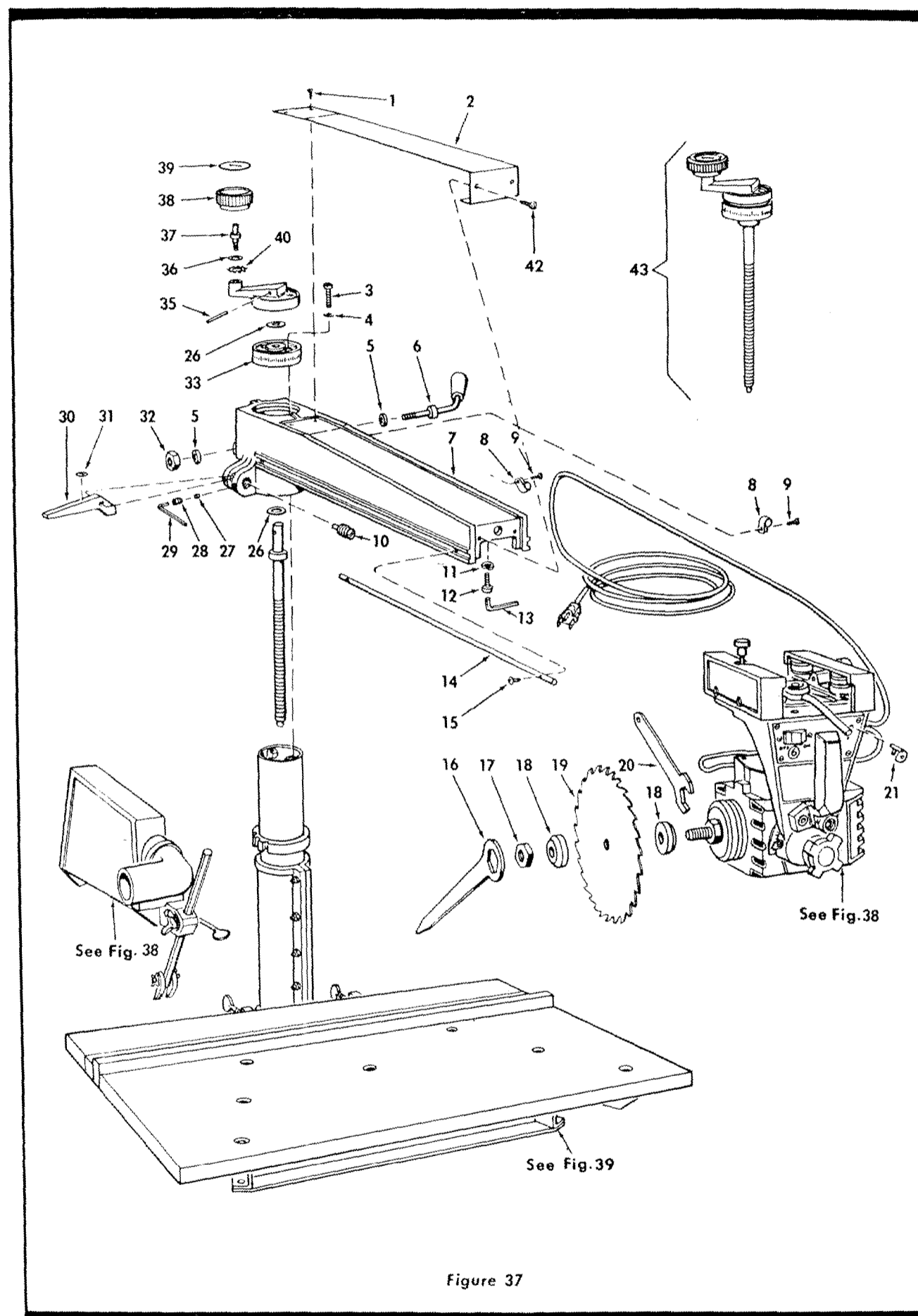

Figure 37

CRAFTSMAN, 9-INCH RADIAL SAW, MODEL No. 113.29350

FIGURE 38 PARTS LIST

| Key No. | Part No. | Description |
|---------|----------|--|
| 1 | 448013 | *Screw, No. 8-32 x 1/2, Type 23C1, Pan Hd. Slotted, Cad. Pl. Steel |
| 2 | 63015 | Cover, Carriage L.H. |
| 3 | 222407 | *Screw, Set, 1/4-20 x 1/2, Hex. Socket Hd., Flat Pt. |
| 4 | 60052 | *Screw, Mach., No. 10-32 x 1-5/8, Fill. Hd. Slotted, Steel |
| 5 | 60050 | *Washer, Plain, .319 x 5/8 x 1/32, Steel |
| 6 | 63026 | Bearing, Carriage |
| 7 | 138540 | Washer, Lock, 5/16, Internal Tooth, Steel |
| 8 | 124824 | *Nut, Hex., 5/16-18 x 1/2 x 3/16, Steel |
| 9 | 63031 | Retainer, Spring |
| 10 | 63071 | Disk, Color (3) |
| 11 | 63013 | Knob, Swivel Index |
| 12 | 63030 | Bumper |
| 13 | 63029 | Arm Assembly, Yoke Clamp |
| 14 | 63004 | Spring, Swivel Latch |
| 15 | 63005 | Pin, Latch |
| 16 | 60051 | *Washer, Plain, .688 x 1-1/8 x 1/32 |
| 17 | 63060 | Shoe, Carriage Lock |
| 18 | 63014 | Cover, Carriage R.H. |
| 19 | 63061 | Knob, Carriage Lock |
| 20 | 63072 | Disk, Color (4) |
| 21 | 30505 | *Wrench, Hex "L", 1/8 Across Flats |
| 22 | 63025 | Washer |
| 23 | 131512 | *Screw, Mach., 5/16-18 x 1-1/2, Sq. Hd., Steel |
| 24 | 63024 | Carriage |
| 25 | 63028 | Plate, Index |
| 26 | 30574 | Ring, Hog |
| 27 | 60055 | Washer, Fiber, .380 x 3/4 x 1/16 |
| 28 | 60054 | Washer, Fiber, .320 x 3/4 x 1/16 |
| 29 | 37363 | Cord and Plug |
| 30 | 30469 | Adapter Plug |
| 31 | 63045 | Grommet |

| Key No. | Part No. | Description |
|---------|----------|--|
| 32 | 448001 | *Screw, No. 6-32 x 1/4, Type 23C1, Pan Hd. Slotted, Cad. Pl. Steel |
| 33 | 63048 | Switch (off-on) |
| 34 | 63047 | Lock Assembly, Switch |
| 35 | 63075 | Disk, Color |
| 36 | 63003 | Handle |
| 37 | 63074 | Disk, Color (5) |
| 38 | 60058 | *Wrench, Hex. "L", 5/16 Across Flats |
| 39 | 60032 | *Screw, 3/8-16 x 1, Hex. Socket Hd. Cap, Plain |
| 40 | 131202 | *Washer, Split Lock, 3/8 x .136 x .070, Steel |
| 41 | 60031 | *Washer, Plain, .440 x 11/16 x 1/32, Steel |
| 42 | 63073 | Disk, Color (5) |
| 43 | 63012 | Knob, Bevel Lock |
| 44 | 63011 | Washer, Knob Clamp |
| 45 | 63010 | Washer, Clamp |
| 46 | 63049 | Indicator |
| 47 | 37935 | Washer, Fiber, .140 x .250 x 1/32 |
| 48 | 63044 | Yoke |
| 49 | 63027 | Stud, Yoke Clamp |
| 50 | 63006 | Bushing, Yoke |
| 51 | 63007 | Bushing, No. 2 Yoke |
| 52 | 63009 | Washer, Motor Clamp |
| 53 | 63039 | Screw, Guard Clamp |
| 54 | 37429 | Elbow, Discharge |
| 55 | 37398 | Pawl Assembly, Anti-Kickback |
| 56 | 30542 | Washer, X |
| 57 | 37400 | Pin, Cross |
| 58 | 30543 | Pawl, Anti-Kickback |
| 59 | 37399 | Rod |
| 60 | 30540 | Screw, Wing |
| 61 | 63040 | Guard Assembly |
| 63 | 26512 | Cap |
| 64 | 9404365 | *Screw, No. 8-32 x 5/16, Self-Tapping, Pan Hd. Slotted |
| 65 | 63182 | Clamp, Guard |

* Standard Hardware Item -- May be Purchased Locally.

CRAFTSMAN, 9-INCH RADIAL SAW, MODEL No. 113.29350

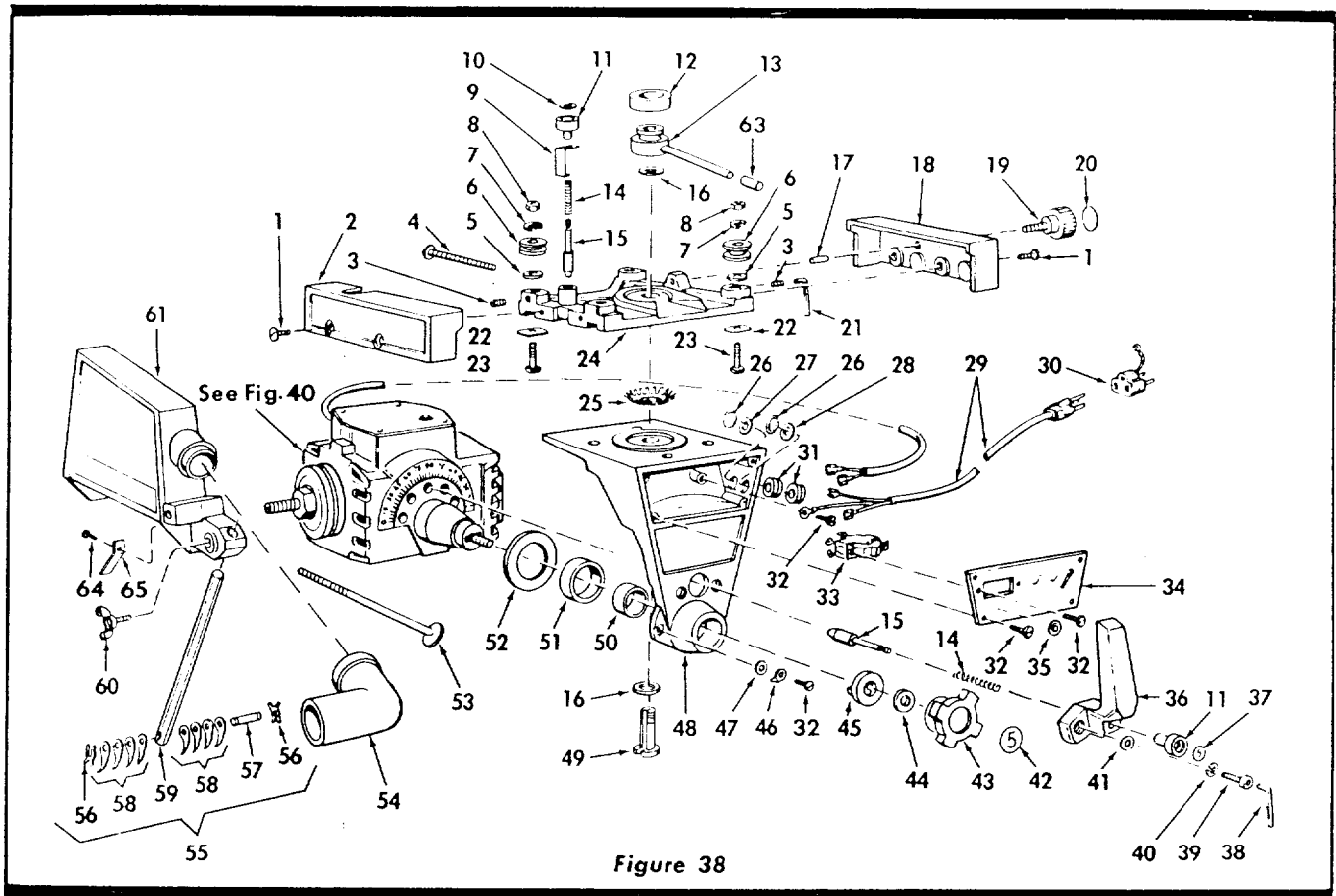

CRAFTSMAN, 9-INCH RADIAL SAW, MODEL No. 113.29350

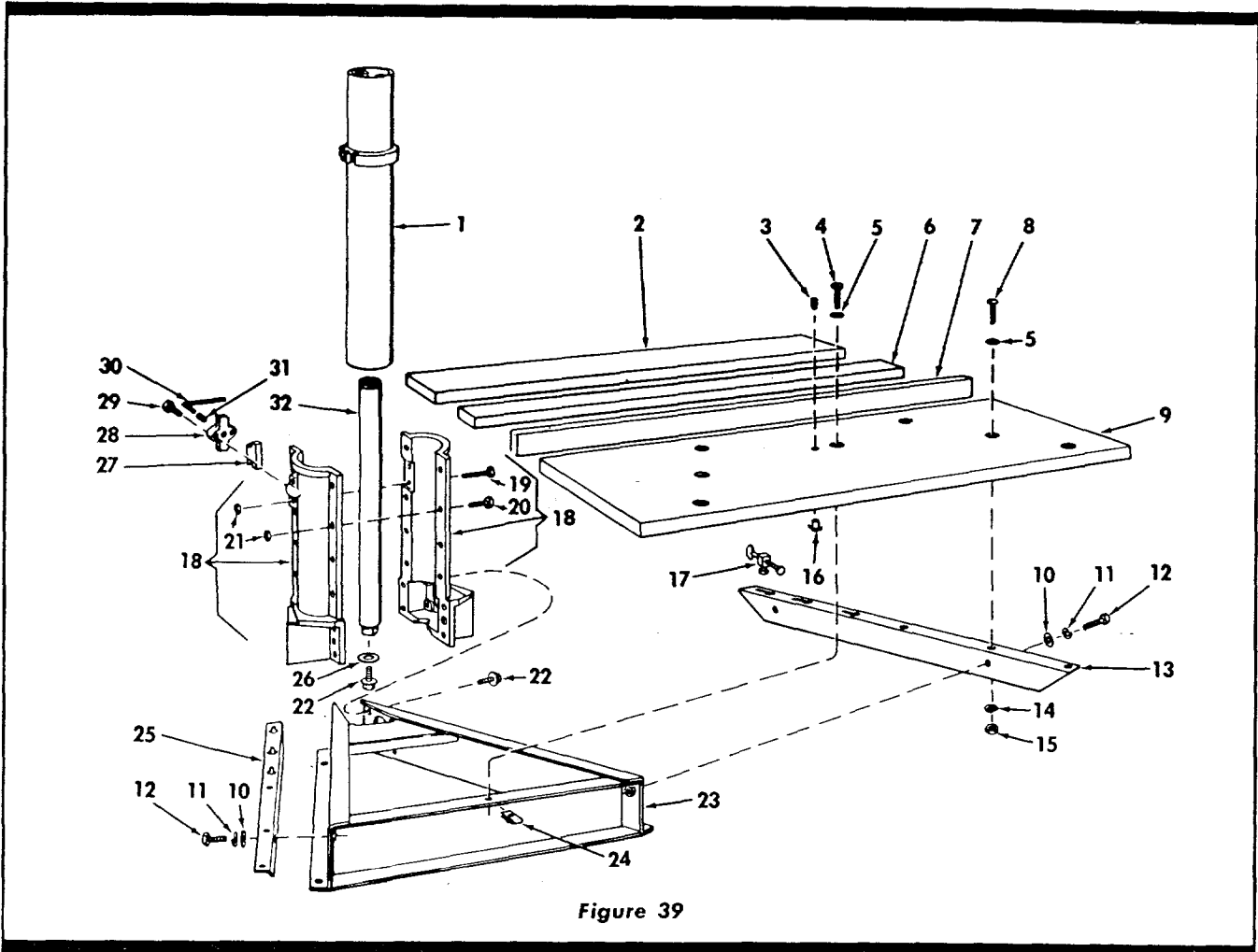

Figure 39

FIGURE 39 PARTS LIST

| Key No. | Part No. | Description |
|---------|----------|--|
| 1 | 63043 | Tube Assembly, Column |
| 2 | 63019 | Table, Rear |
| 3 | 102707 | *Screw, Set, Slotted, 1/4-20 x 1/2 |
| 4 | 60057 | *Screw, Mach., 1/4-20 x 1-1/4, Pan Hd. Slotted |
| 5 | 37937 | *Washer, Plain, 17/64 x 5/8 x 1/32, Steel |
| 6 | 63020 | Table, Spacer |
| 7 | 63021 | Fence, Rip |
| 8 | 60056 | *Screw, Mach., 1/4-20 x 1, Pan Hd. Slotted |
| 9 | 63018 | Table, Front |
| 10 | 60013 | *Washer, Plain, 11/32 x 7/8 x 1/16, Steel |
| 11 | 131201 | *Washer, Split Lock, 5/16 S.A.E., Steel |
| 12 | 60033 | *Screw, Mach., 5/16-18 x 3/4, Hex. Hd., Steel |
| 13 | 63022 | Table Support, R.H. |
| 14 | 115109 | *Washer, Split Lock, 1/4 x .109 x .062, Steel |
| 15 | 115120 | *Nut, Hex., 1/4-20 x 7/16 x 3/16, Steel |

| Key No. | Part No. | Description |
|---------|----------|---|
| 16 | 37384 | *Nut, "T" |
| 17 | 63059 | Clamp, Table |
| 18 | 63041 | Support Assembly, Column |
| 19 | 60035 | *Screw, Mach., 1/4-28 x 1-3/4, Hex. Hd. Ind., Steel |
| 20 | 60034 | *Screw, Mach., 1/4-28 x 7/8, Hex. Hd. Ind., Steel |
| 21 | 60036 | Nut, Lock |
| 22 | 9416187 | *Screw, 5/16-18 x 3/4, Type 23C1, Hex. Washer Hd., Steel |
| 23 | 63000 | Base |
| 24 | 37530 | Nut, "U" Clip, 1/4-20 |
| 25 | 63023 | Table Support, L.H. |
| 26 | 63056 | Washer, Elevation Tube |
| 27 | 63057 | Key, Column Tube |
| 28 | 63058 | Cover, Key |
| 29 | 274622 | *Screw, 1/4-20 x 1, Type 23, Hex. Washer Hd. Ind., Steel |
| 30 | 37911 | Wrench, Hex. "L", 3/16 Across Flats |
| 31 | 222506 | *Screw, Set, 3/8-16 x 5/8, Socket Hex. Hd., Flat Pt., Steel |
| 32 | 63042 | Tube Assembly, Elevation |

* Standard Hardware Item -- May be Purchased Locally.

CRAFTSMAN, 9-INCH RADIAL SAW, MODEL No. 113.29350

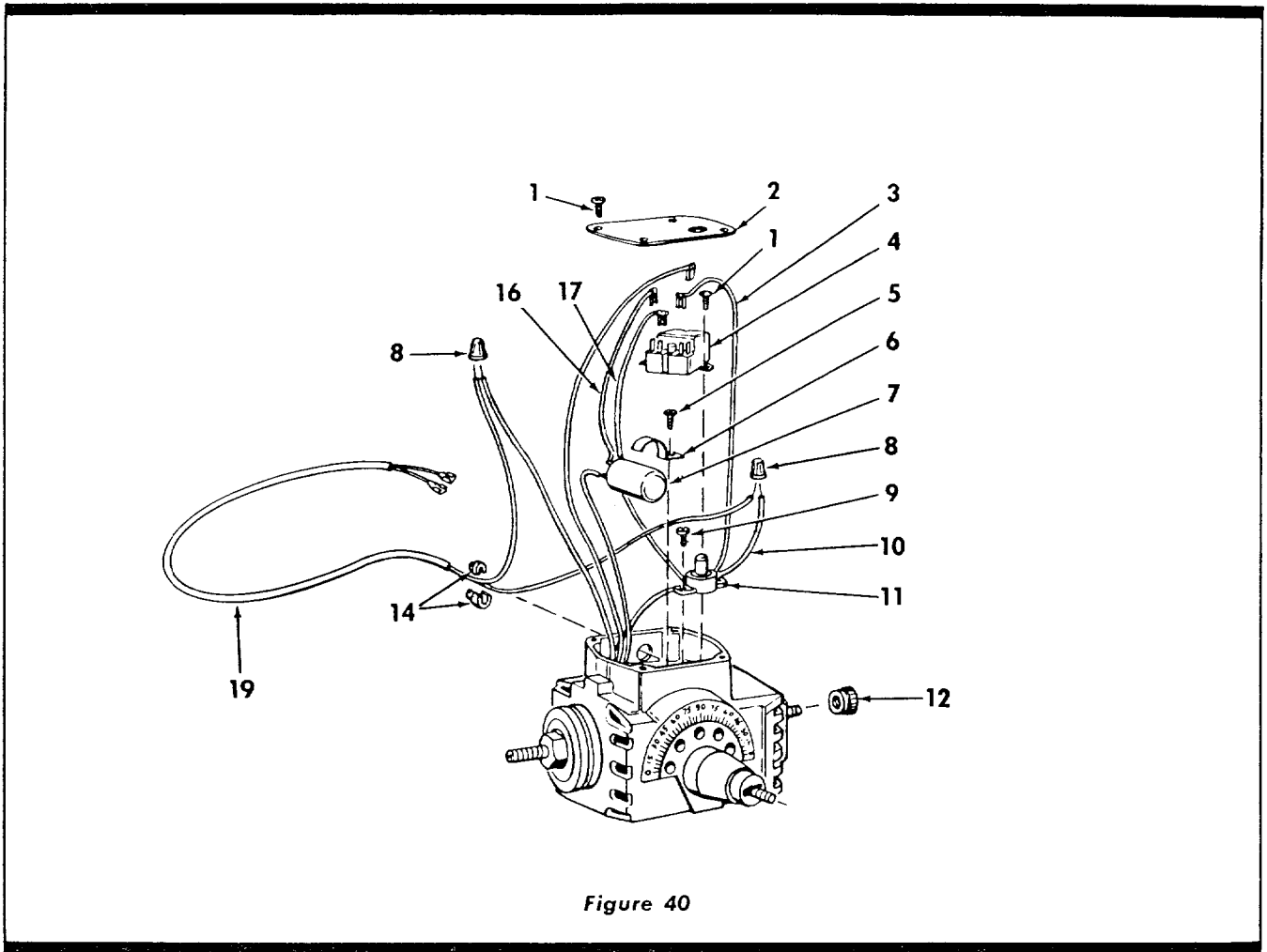

Figure 40

FIGURE 40 PARTS LIST

| Key No. | Part No. | Description |
|---------|-----------------|--|
| 1 | 63092 448001 | Complete Motor Assembly *Screw, No. 6-32 x 1/4, Type 23C1, Pan Hd. Slotted, Cad. Pl. Steel |
| 2 | 63016 | Cover and Nameplate |
| 3 | 63066 | Lead Assembly |
| 4 | 63064 | Relay, Starting |
| 5 | 448011 | *Screw, No. 8-32 x 3/8, Type 23C1, Pan Hd. Slotted, Cad. Pl. Steel |
| 6 | 30700 | Clamp, Capacitor |
| 7 | 63063 | Capacitor |

| Key No. | Part No. | Description |
|---------|----------|--|
| 8 | 30573 | Nut, Wire |
| 9 | 9404353 | *Screw, No. 6-32 x 7/16, Type 23C1, Pan Hd. Slotted, Cad. Pl. Steel |
| 10 | 63068 | Wire, No. 16, 4" Long, AWG U.L. Approved |
| 11 | 37408 | Protector, Thermal |
| 12 | 30582 | Cap, Shaft |
| 14 | 37818 | Relief, Strain |
| 16 | 63065 | Lead Assembly |
| 17 | 63067 | Lead Assembly |
| 19 | 63125 | Cord |

* Standard Hardware Item — May be Purchased Locally.

