

# WEIDER 8510

PATENT PENDING

Model No. WESY85100

Serial No. \_\_\_\_\_

Write the serial number in the space above for future reference.

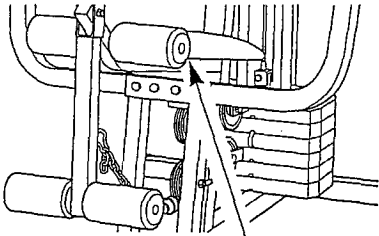

Serial Number Decal

## QUESTIONS?

As a manufacturer, we are committed to providing complete customer satisfaction. If you have questions, or find that there are missing or damaged parts, we will guarantee you complete satisfaction through direct assistance from our factory.

TO AVOID UNNECESSARY DELAYS, PLEASE CALL DIRECT TO OUR TOLL-FREE CUSTOMER HOT LINE. The trained technicians on our customer hot line will provide immediate assistance, free of charge to you.

CUSTOMER HOT LINE:

**1-800-225-0653**

Mon.-Fri., 6 a.m.-6 p.m. MST

## CAUTION!

Read all precautions and instructions in this manual before using this equipment. Save this manual for future reference.

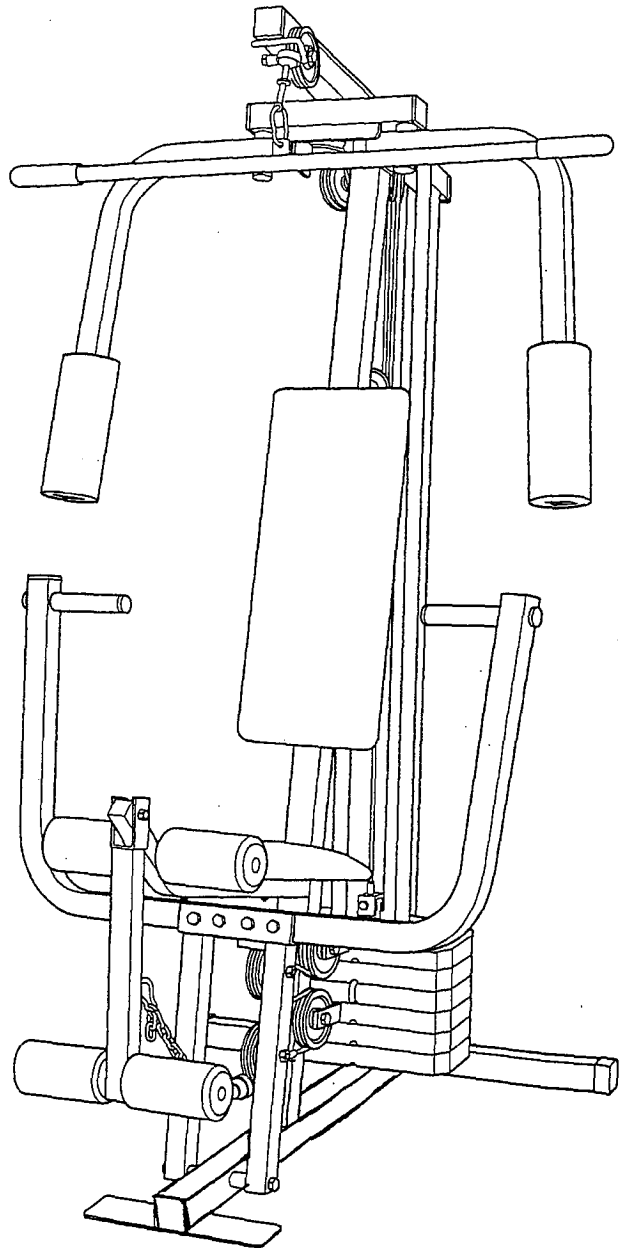

# USER'S MANUAL

# TABLE OF CONTENTS

LIMITED WARRANTY .....	.2
IMPORTANT PRECAUTIONS .....	.3
BEFORE YOU BEGIN .....	.4
ASSEMBLY .....	.5
HOW TO USE THE HOME GYM SYSTEM .....	.14
TROUBLE-SHOOTING AND MAINTENANCE .....	.16
CABLE DIAGRAM .....	.17
PART LIST .....	.18
EXPLODED DRAWING .....	.19
ORDERING REPLACEMENT PARTS .....	.Back Cover

Note: A PART IDENTIFICATION CHART is attached to the center of this manual. Remove the PART IDENTIFICATION CHART before beginning assembly.

## LIMITED WARRANTY

ICON Health & Fitness, Inc. (ICON), warrants this product to be free from defects in workmanship and material, under normal use and service conditions, for a period of ninety (90) days from the date of purchase. This warranty extends only to the original purchaser. ICON's obligation under this warranty is limited to replacing or repairing, at ICON's option, the product at one of its authorized service centers. All products for which warranty claim is made must be received by ICON at one of its authorized service centers with all freight and other transportation charges prepaid, accompanied by sufficient proof of purchase. All returns must be pre-authorized by ICON. This warranty does not extend to any product or damage to a product caused by or attributable to freight damage, abuse, misuse, improper or abnormal usage or repairs not provided by an ICON authorized service center, for products used for commercial or rental purposes, or for products used as store display models. No other warranty beyond that specifically set forth above is authorized by ICON.

ICON is not responsible or liable for indirect, special or consequential damages arising out of or in connection with the use or performance of the product or damages with respect to any economic loss, loss of property, loss of revenues or profits, loss of enjoyment or use, costs of removal, installation or other consequential damages of whatsoever nature. Some states do not allow the exclusion or limitation of incidental or consequential damages. Accordingly, the above limitation may not apply to you.

The warranty extended hereunder is in lieu of any and all other warranties and any implied warranties of merchantability or fitness for a particular purpose is limited in its scope and duration to the terms set forth herein. Some states do not allow limitations on how long an implied warranty lasts. Accordingly, the above limitation may not apply to you.

This warranty gives you specific legal rights. You may also have other rights which vary from state to state.

ICON HEALTH & FITNESS, INC., 1500 S. 1000 W., LOGAN, UT 84321-9813

# IMPORTANT PRECAUTIONS

**WARNING:** To reduce the risk of serious injury, read the following important precautions before using the home gym system.

1. Read all instructions in this manual and in the accompanying literature before using the home gym system.
2. Use the home gym system only on a level surface. Cover the floor beneath the home gym system for protection.
3. Inspect and tighten all parts often. Replace any worn parts immediately.
4. Keep small children away from the home gym system at all times.
5. Always wear athletic shoes for foot protection.
6. Always stand on the foot plate when performing an exercise that could cause the home gym system to tip.
7. Never release the press arm, butterfly arms, leg lever, lat bar or nylon strap while weights are raised. The weights will fall with great force.
8. Keep hands and feet away from moving parts.
9. Make sure that the cables remain on the pulleys at all times. If the cables bind while you are exercising, stop immediately and make sure that the cables are on all of the pulleys.
10. Always disconnect the lat bar from the home gym system when performing an exercise that does not use the lat bar.
11. If you feel pain or dizziness at any time while exercising, stop immediately and begin cooling down.

**WARNING:** Before beginning this or any exercise program, consult your physician. This is especially important for persons over the age of 35 or persons with pre-existing health problems. Read all instructions before using. ICON assumes no responsibility for personal injury or property damage sustained by or through the use of this product.

# BEFORE YOU BEGIN

Thank you for selecting the versatile WEIDER® 8510 Home Gym System. The WEIDER® 8510 offers a selection of weight stations designed to develop every major muscle group of the body. Whether your goal is to tone your body, build dramatic muscle size and strength, or improve your cardiovascular system, the WEIDER® 8510 will help you to achieve the specific results you want.

Service Department toll-free at 1-800-225-0653, Monday through Friday, 6 a.m. until 6 p.m. Mountain Time (excluding holidays). To help us assist you, please note the product model number and serial number before calling. The model number is WESY85100. The serial number can be found on a decal attached to the WEIDER® 8510 (see the front cover of this owner's manual).

**For your benefit, read this manual carefully before using the WEIDER® 8510 Home Gym System.** If you have additional questions, please call our Customer

Before reading further, please review the drawing below and familiarize yourself with the parts that are labeled.

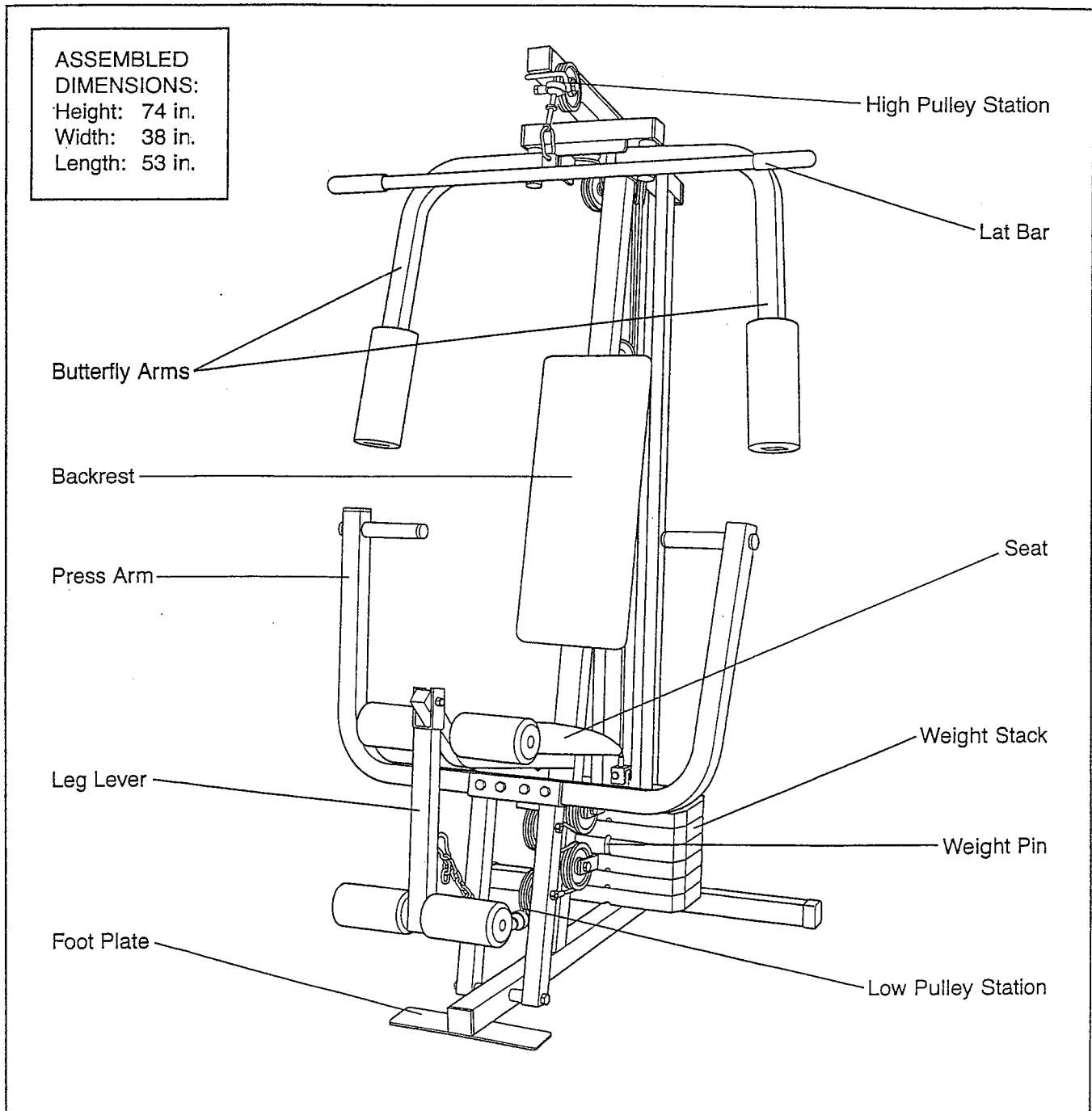



# ASSEMBLY

Before beginning assembly, carefully read the following information and instructions:

- Place all parts of the WEIDER 8510 in a cleared area and remove the packing materials; do not dispose of the packing materials until assembly is completed.
- The assembly is divided into four stages: 1) frame assembly, 2) press and butterfly arm assembly, 3) cable and pulley assembly, and 4) seat and backrest assembly. The hardware for each stage is packaged separately.
- Wait until you begin each assembly stage to open that parts bag.
- For help identifying the small parts used in assembly, use the **PART IDENTIFICATION CHART** located in the center of this manual. Note: Some small parts may have been pre-attached for shipping. If a part is not in the parts bag, check to see if it has been pre-attached.

- As you assemble the WEIDER 8510, be sure that all parts are oriented as shown in the drawings.
- Tighten all parts as you assemble them, unless instructed to do otherwise.

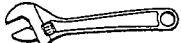
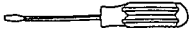
**THE FOLLOWING TOOLS (NOT INCLUDED) ARE REQUIRED FOR ASSEMBLY:**

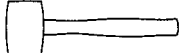
- Two (2) adjustable wrenches 
- One (1) standard screwdriver 
- One (1) phillips screwdriver 
- One (1) rubber mallet 
- Lubricant, such as grease or petroleum jelly, and soapy water will also be needed.

Assembly will be more convenient if you have the following tools: A socket set, a set of open-end or closed-end wrenches, or a set of ratchet wrenches.

## FRAME ASSEMBLY

1. Before beginning assembly, be sure that you have read and understand the information in the box above.

Press a 2" Square Outer Cap (51) onto each end of the Stabilizer (5). Press a 2" Square Inner Cap (27) into the end of the Base (4).

Insert two 5/16" x 2 3/4" Carriage Bolts (14) up through the Stabilizer (5). Insert two 5/16" x 2 1/2" Carriage Bolts (1) up through the Base (4).

Slide the indicated end of the Base (4) onto the 5/16" x 2 3/4" Carriage Bolts (14) in the Stabilizer (5). Slide the Rear Upright (56) onto the Carriage Bolts. The high side of the bracket on the Rear Upright should be on the side shown. Hand-tighten a 5/16" Nylon Locknut (3) onto each Carriage Bolt. Do not tighten the Nylon Locknuts yet.

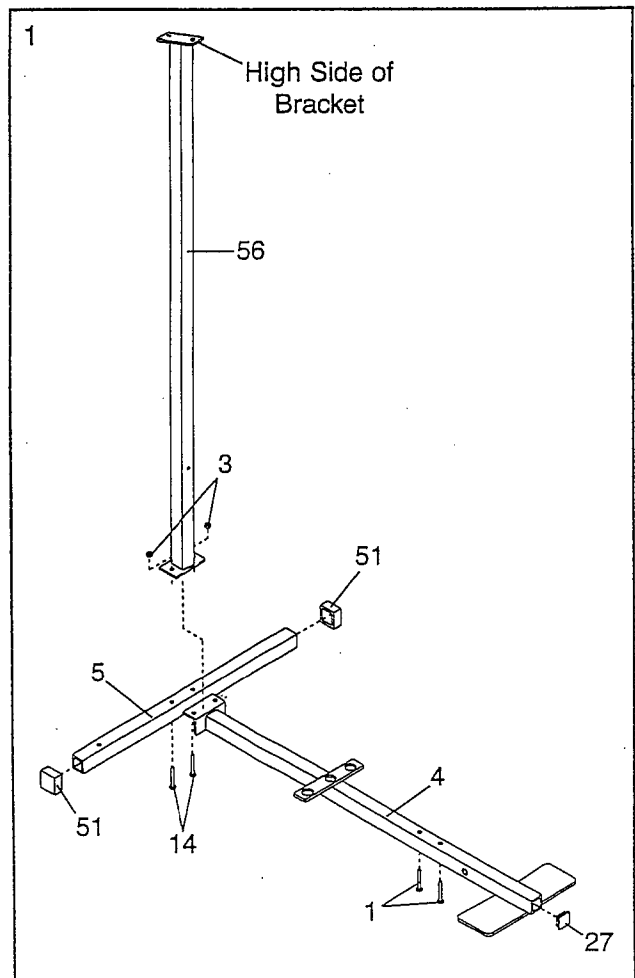

- Slide the Front Upright (42) onto the 5/16" x 2 1/2" Carriage Bolts (1). Hand-tighten a 5/16" Nylon Locknut (3) onto each Carriage Bolt. **Do not tighten the Nylon Locknuts yet.**

Press a 1" Square Inner Cap (65) into the Front Upright (42).

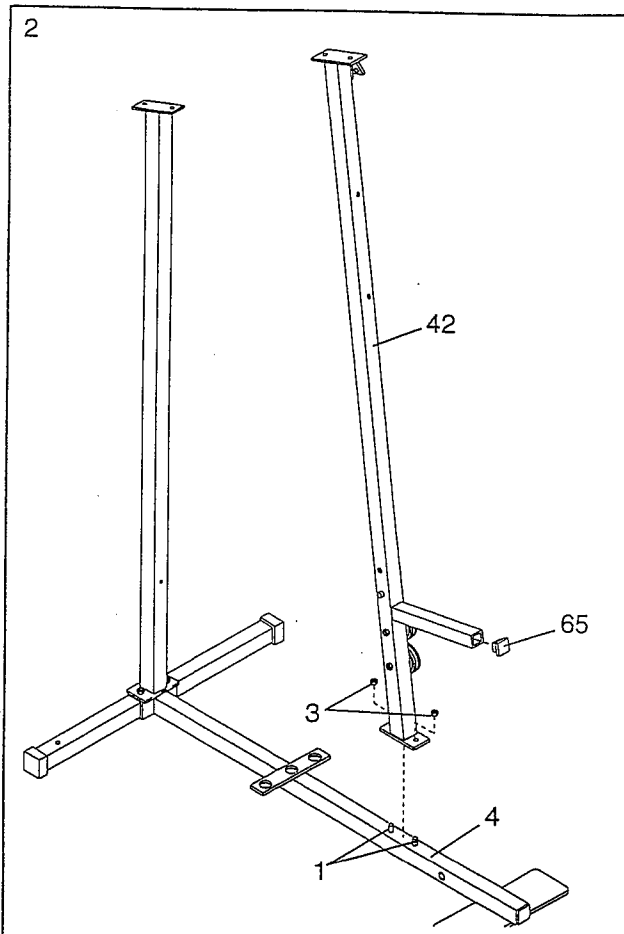

- Press a 2" Square Inner Cap (27) into each end of the Top Frame (55). Press a 1 3/4" Square Inner Cap (44) into each end of the crossbar on the Top Frame. Press two 1" Round Inner Caps (49) into the top of the crossbar.

Attach the Top Frame (55) to the Front Upright (42) and the Rear Upright (56) with four 5/16" x 2 3/4" Bolts (11), four 5/16" Flat Washers (8), and four 5/16" Nylon Locknuts (3).

**Tighten all Nylon Locknuts used in steps 1 through 3.**

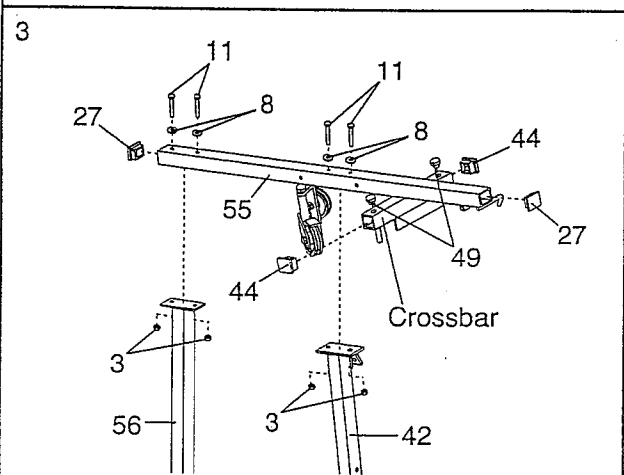

- Set two Weight Bumpers (19) onto the bracket on the Base (4) as shown.

Stack six Weights (25) onto the Weight Bumpers (19). **Be sure that the pin grooves are all on the same side and that the "weider" logo is on top.**

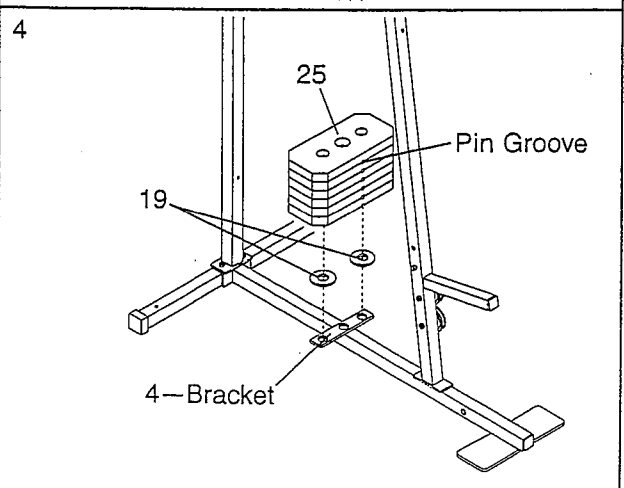

5. Press the Weight Tube Bumper (64) into the end of the Weight Tube (63). Insert the Weight Tube into the stack of Weights (25). **Be sure that the pins on the Weight Tube are sitting in the pin grooves in the top Weight.**

Lubricate the inside of the holes in the Top Weight. Set the Top Weight (76) onto the stack of Weights (25). Insert both Weight Guides (62) into the stack of Weights. **Be sure that the holes in the Weight Guides are at the top, as shown.**

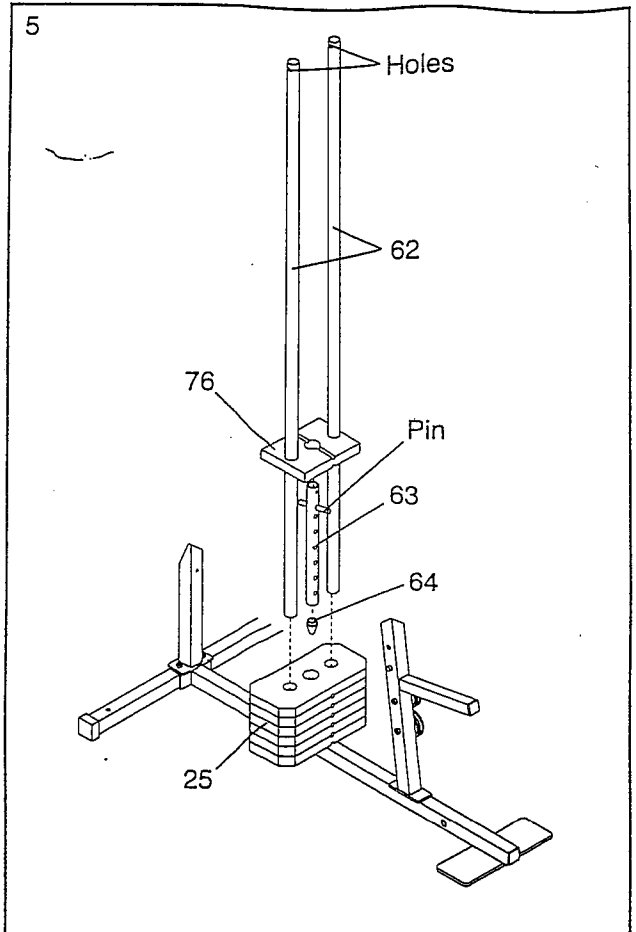

6. Attach the upper ends of the Weight Guides (62) to the Top Frame (55) with the 5/16" x 6" Bolt (60), two 1/2" x 3/4" Spacers (61), and a 5/16" Nylon Locknut (3).

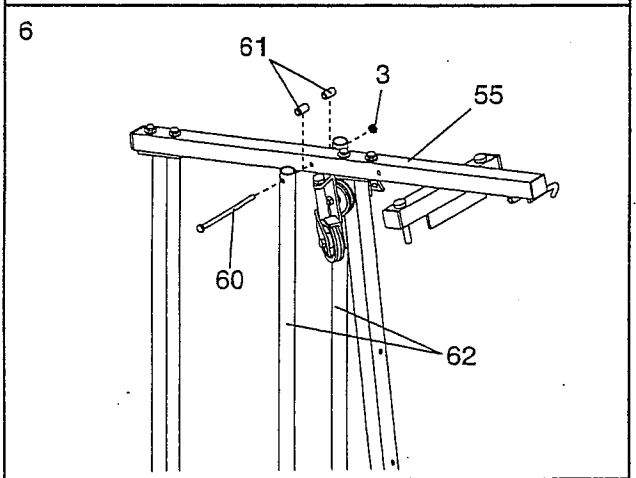

7. Press a 1" x 7/8" Plastic Bushing (75) onto each welded spacer on the Press Frame (17). Slide the Press Frame into place on the Base (4). **Note: This will be a tight fit. The 1" x 7/8" Plastic Bushings should fit on each end of the indicated tube in the Base. Be sure that the pulleys are on the indicated side.**

Lubricate the 3/8" x 8" Bolt (59). Attach the Press Frame (17) to the Base (4) with the 3/8" x 8" Bolt and a 3/8" Nylon Locknut (21).

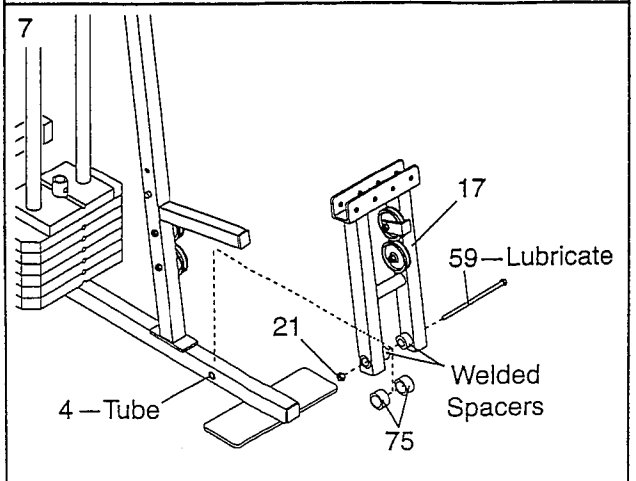

- Press a 1 3/4" Square Inner Cap (44) into the top of a Press Arm (46). Press a 1" Round Inner Cap (49) into each end of the handle on the Press Arm. Attach the Press Arm to one side of the Press Frame (17) with two 5/16" x 2 1/2" Bolts (22) and two 5/16" Nylon Locknuts (3).

Assemble the other Press Arm (46) in the same manner.

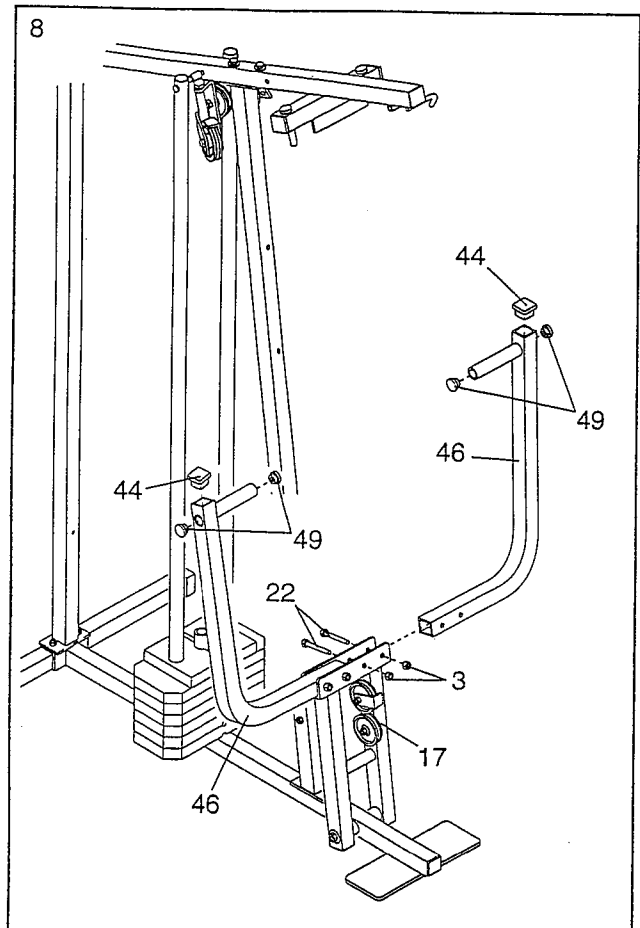

- Lubricate both axles on the Top Frame (55).

Slide the Right Arm (48) onto the right axle. **Be careful not to confuse the Right Arm with the Left Arm (47); note the position of the "V" Pulley (6) to identify the Right Arm. Be sure that the upper end of the Right Arm is behind the indicated bracket on the Top Frame (55).**

Tap two 1" Retainers (69) and a 1" Round Cover Cap (70) onto the axle. **Be sure that the teeth on the Retainers bend toward the Cover Cap, as shown in the inset drawing.**

Attach the Left Arm (47) in the same manner.

Press 1 3/4" Square Inner Caps (44) into the lower ends of the Right and Left Arms (47, 48). Wet the lower end of each Arm with soapy water. Slide a 10" Pad (45) onto the lower end of each Arm.

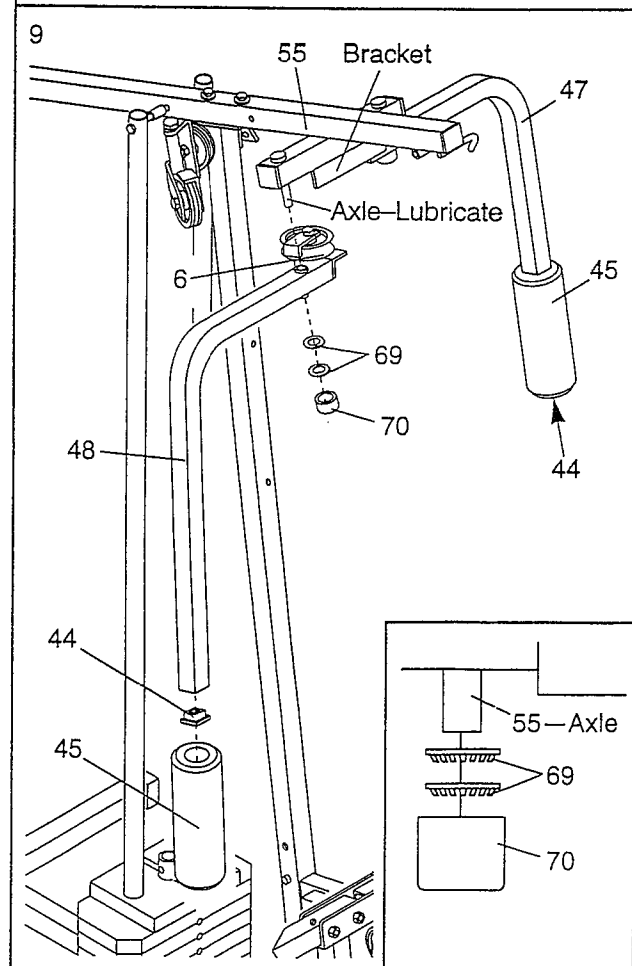



As you assemble the cables and pulleys in steps 10 through 18, please refer to the **CABLE DIAGRAM** on page 17 of this manual.

- Route the Long Cable (23) around the 3 1/2" Pulley (15) attached to the Top Frame (55). **Be sure that the end of the Cable with the ball is on the indicated side of the Pulley and that the Cable is between the Pulley and the hook on the Top Frame.** Tighten the 3/8" x 3 3/4" Bolt (71) and the 3/8" Nylon Locknut (not shown).

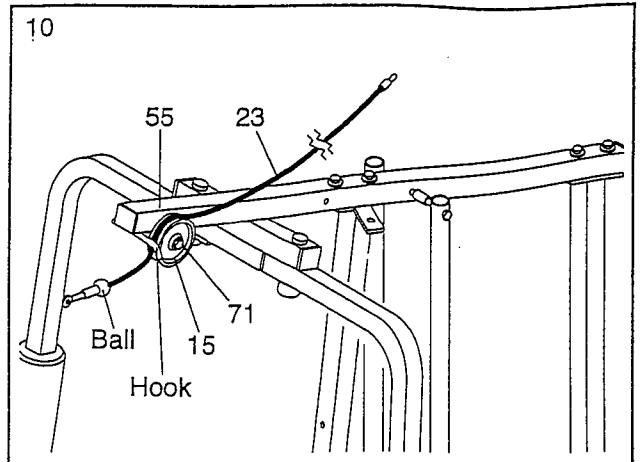

- Wrap the Long Cable (23) around a "V"-Pulley (6). Attach the "V"-Pulley and a Long Cable Trap (50) to the indicated bracket on the Front Upright (42) with a 3/8" x 2 1/2" Bolt (7) and a 3/8" Nylon Locknut (21).

Route the Long Cable (23) around the "V"-Pulley (6) on the Left Arm (47). **Be sure that the Cable is in the groove of the Pulley and that the Long Cable Trap (50) is turned to hold the Cable in place.** Tighten the 3/8" x 2 1/2" Bolt (7) and the 3/8" Nylon Locknut (not shown).

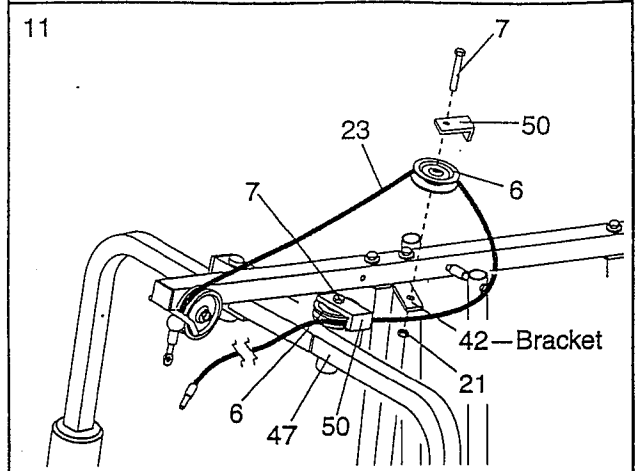

- Route the Long Cable (23) around the "V"-Pulley (6) at the top of the Right Arm (48). **Be sure that the Cable is in the groove of the "V"-Pulley and that the Long Cable Trap (50) is turned to hold the Cable in place.** Tighten the 3/8" x 2 1/2" Bolt (7) and the 3/8" Nylon Locknut (not shown).

Route the Long Cable (23) around the 3 1/2" Pulley (15) attached to the Pulley Bracket (20). **Be sure that the Cable is in the groove of the Pulley and that the Cable Trap (66) is turned to hold the Cable in place.** Tighten the 3/8" x 2" Bolt (12) and the 3/8" Nylon Locknut (not shown).

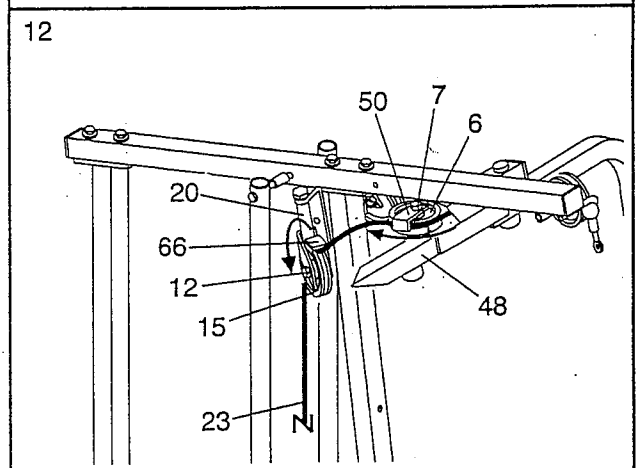

- See the inset drawing. Attach a 3 1/2" Pulley (15) and a Cable Trap (66) to the indicated hole in the Long "U"-Bracket (57) with a 3/8" x 2" Bolt (12) and a 3/8" Nylon Locknut (21). **Be sure that the Cable Trap is inside the "U"-Bracket. Note: This may come pre-assembled.**

Route the Long Cable (23) through the 3 1/2" Pulley (15) and Long "U"-Bracket (57). **Be sure that the Cable is in the groove of the Pulley and that the Cable and Pulley move smoothly.**

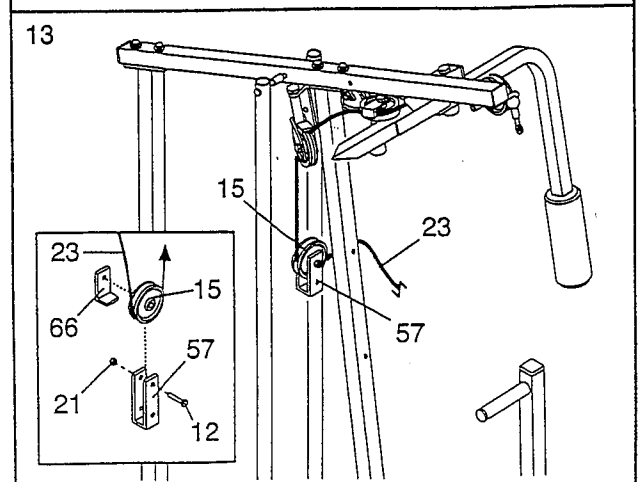

14. Route the Long Cable (23) around the 3 1/2" Pulley (15) attached to the bracket on the Top Frame (55). Tighten the 3/8" x 2" Bolt (12) and the 3/8" Nylon Locknut (21). (Note: This Pulley is pre-assembled. It has been shown disassembled for easy part identification.) Be sure that the Cable is in the groove of the Pulley and that the Cable and Pulley move smoothly.

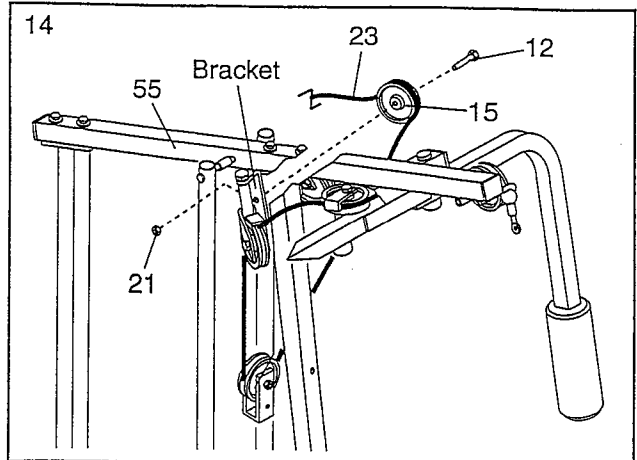

15. Attach the Long Cable (23) to the Small "U"-Bracket (67) with a 1/4" Nylon Locknut (2) and a 1/4" Flat Washer (10). Do not completely tighten the Nut. It should be threaded onto the end of the Cable only a couple of turns.

Attach the Small "U"-Bracket (67) to the Weight Tube (63) with the 5/16" x 1 1/2" Bolt (72) and a 5/16" Nylon Locknut (3).

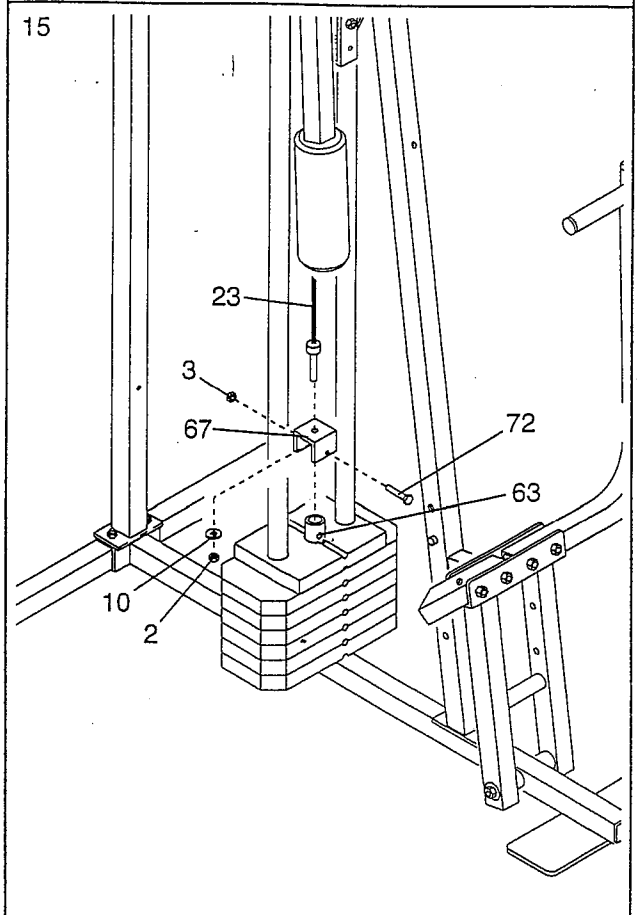

16. Route the Short Cable (58) under the 3 1/2" Pulley (15) attached to the lower hole in the Press Frame (17). Be sure that the end of the Cable with the ball is on the indicated side of the Press Frame and that the Cable is between the Pulley and the crossbar on the Press Frame. Tighten the 3/8" Nylon Locknut (21) and 3/8" x 3 3/4" Bolt (not shown).

Route the Short Cable (58) around the 3 1/2" Pulley (15) attached to the lower hole in the Front Upright (42). Be sure that the Cable Trap (not shown) is turned to hold the Cable in place and that the Cable is routed around the Pulley as shown. Tighten the 3/8" Nylon Locknut (21) and 3/8" x 3 3/4" Bolt (not shown).

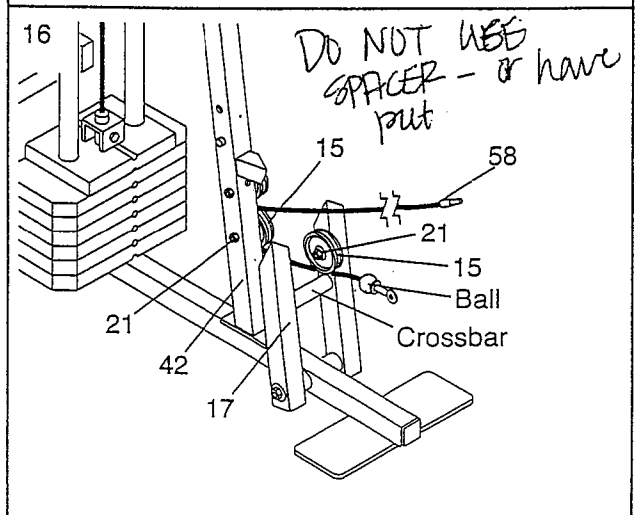

17. Route the Short Cable (58) around the 3 1/2" Pulley (15) attached to the upper hole in the Press Frame (17). **Be sure that the Cable Trap (66) is in the "3 o'clock" position and that the Cable is routed around the Pulley as shown.** Tighten the 3/8" Nylon Locknut (21) and 3/8" x 3 1/2" Bolt (not shown).

Route the Short Cable (58) around the 3 1/2" Pulley (15) attached to the upper hole in the Front Upright (42). **Be sure that the Cable Trap (not shown) is turned to hold the Cable in place and that the Cable is routed around the Pulley as shown.** Tighten the 3/8" Nylon Locknut (21) and 3/8" x 3 3/4" Bolt (not shown).

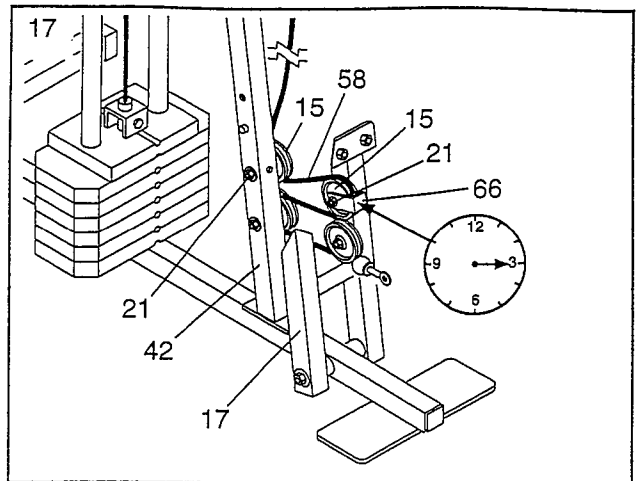

18. Attach the end of the Short Cable (58) to the Long "U"-Bracket (57) with a 1/4" Nylon Locknut (2) and a 1/4" Flat Washer (10). **Do not completely tighten the Nut. It should be threaded onto the end of the Cable only a couple of turns.**

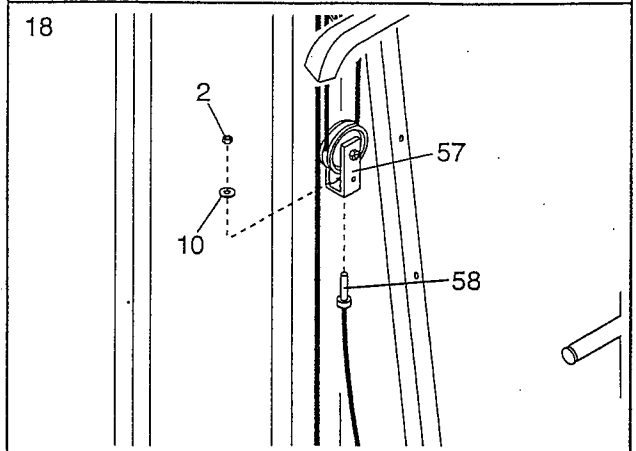

19. Attach the Backrest (41) to the Front Upright (42) with two 1/4" x 2 1/2" Screws (43) and two 1/4" Flat Washers (10).

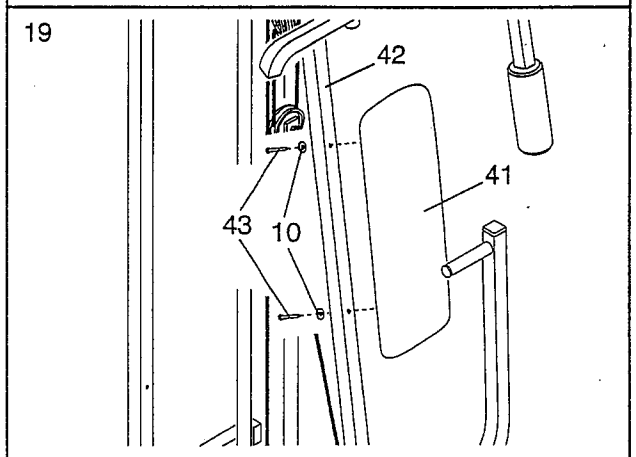

20. Press a 1 1/2" Square Inner Cap (32) into the Seat Frame (36).

Insert the 1/4" x 2" Carriage Bolt (38) through the center hole in the Seat Plate (37). Attach the Seat Plate to the Seat (13) with two 1/4" x 1/2" Screws (18).

Insert the 1/4" x 2" Carriage Bolt (38) through the indicated hole in the Seat Frame (36). Tighten a 1/4" Nylon Locknut (2) with a 1/4" Flat Washer (10) onto the Carriage Bolt.

Attach the other end of the Seat (13) to the Seat Frame (36) with a 1/4" Flat Washer (10) and the 1/4" x 2" Screw (24).

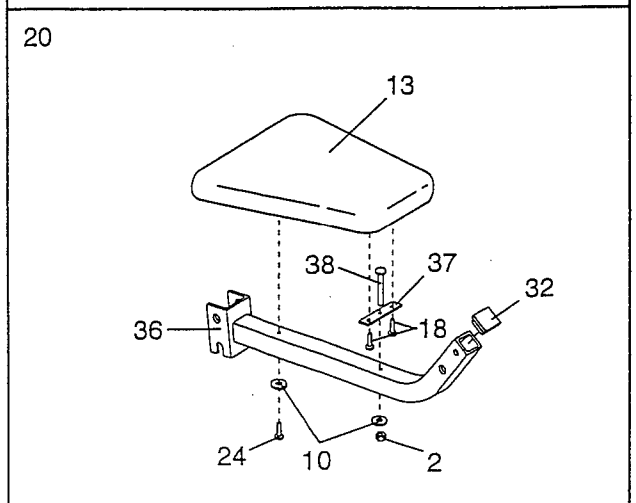

21. Press a 1 1/2" Square Inner Cap (32) into the Leg Lever (29).

Lubricate the 5/16" x 2 1/4" Bolt (33). Attach the Leg Lever (29) to the Seat Frame (36) with the 5/16" x 2 1/4" Bolt and a 5/16" Nylon Locknut (3).

Insert the 5/16" x 2" Eyebolt (35) into the Leg Lever (29) from the direction shown. Tighten a 5/16" Nylon Locknut (3) with a 5/16" Flat Washer (8) onto the Eyebolt.

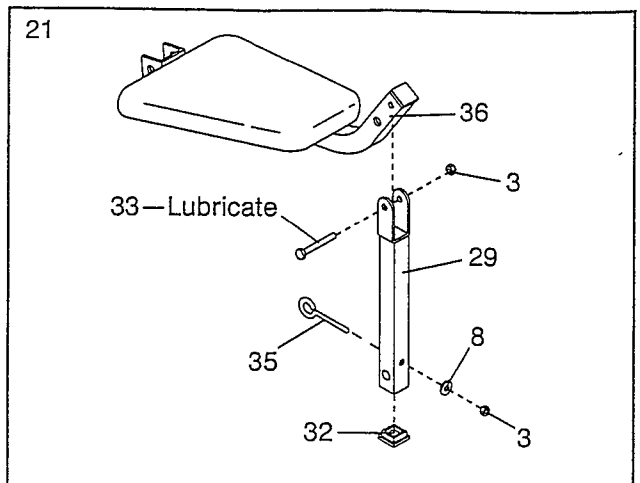

22. Rest the Seat Frame (36) on the indicated pin in the Front Upright (42). Attach the Seat Frame to the Front Upright with a 5/16" x 2 3/4" Carriage Bolt (14) and the Seat Knob (40).

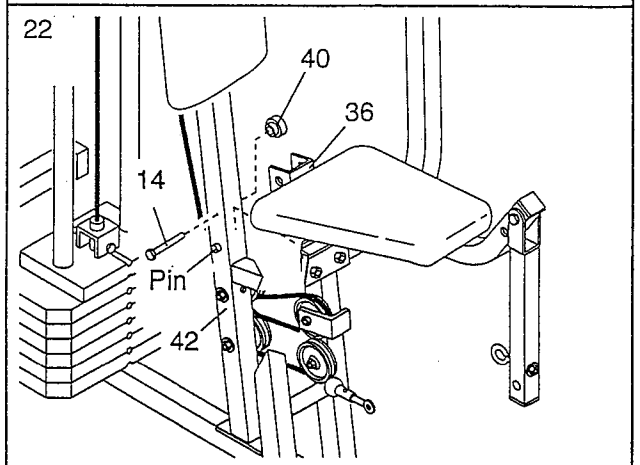

23. Press 3/4" Round Inner Caps (34) into the ends of both 12 1/2" Pad Tubes (28).

Insert one 12 1/2" Pad Tube (28) into the Seat Frame (36). Slide a 5 1/2" Pad (30) onto each end of the Pad Tube.

Insert the other 12 1/2" Pad Tube (28) into the Leg Lever (29). Slide a 5 1/2" Pad (30) onto each end of the Pad Tube.

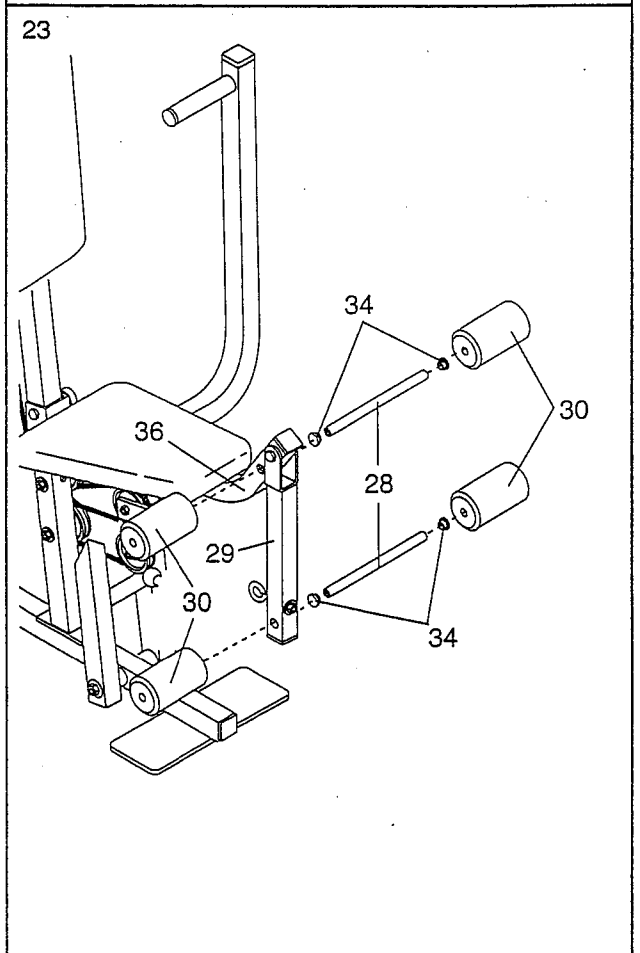

24. Remove the decals from the Decal Sheet (not shown) and apply them to the home gym system in the locations shown in the illustration below.

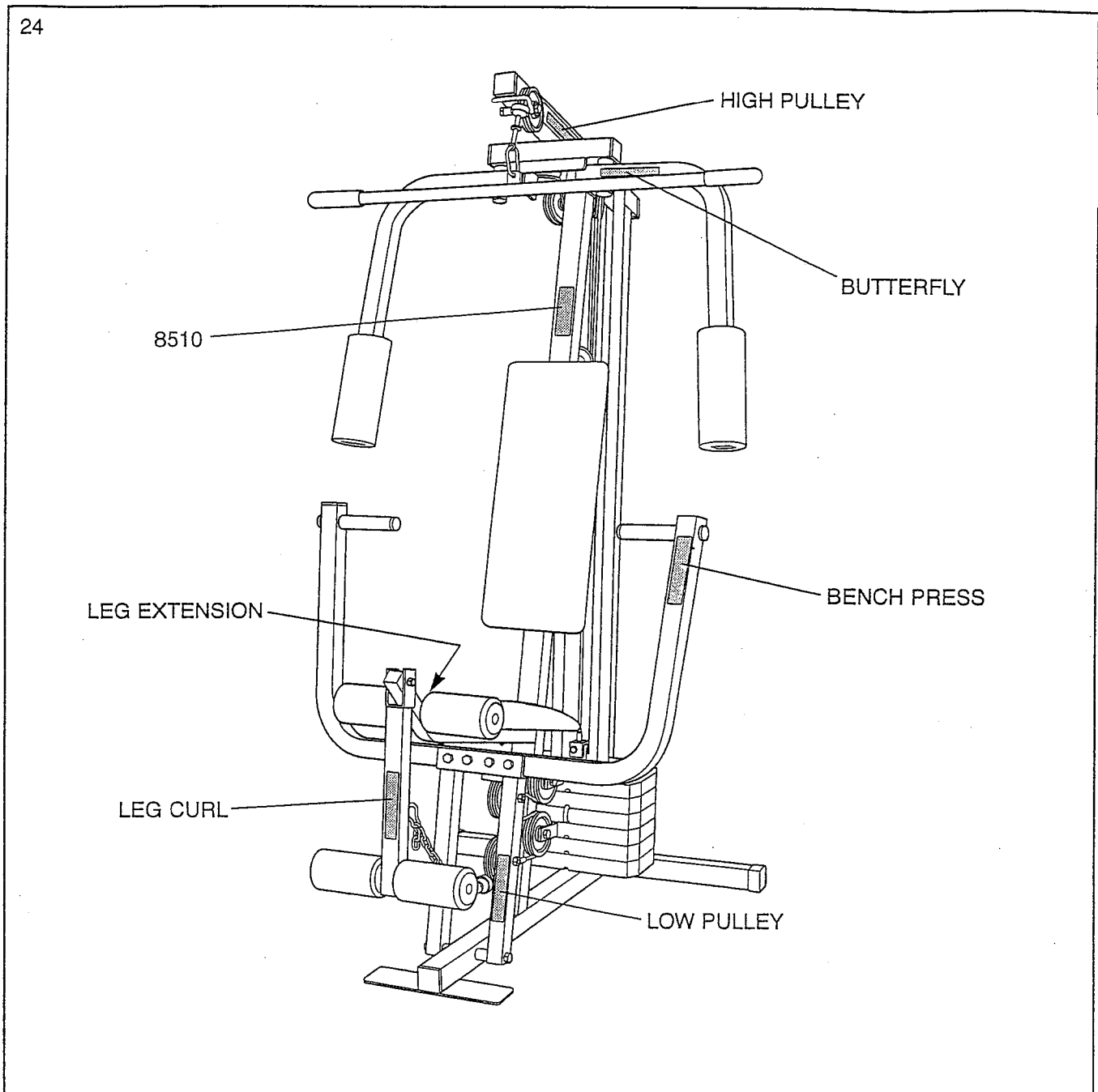

25. Make sure that all parts have been properly tightened. Use of the remaining parts will be explained in HOW TO USE THE HOME GYM SYSTEM, beginning on page 14 of this manual.

Before using the home gym system, pull each cable a few times to be sure that the cables move smoothly over the pulleys. If one of the cables does not move smoothly, find and correct the problem. **IMPORTANT: If the cables are not properly installed, they may be damaged when heavy weight is used. See the CABLE DIAGRAM on page 17 of this manual for proper cable routing. If there is any slack in the cables, the cables should be tightened. See TROUBLE-SHOOTING AND MAINTENANCE on page 16.**

# HOW TO USE THE HOME GYM SYSTEM

The instructions below describe how each part of the home gym system can be adjusted. Refer to the exercise poster accompanying this manual to see how the home gym system should be set up for each exercise. **IMPORTANT:** When attaching the lat bar or nylon strap, make sure that the attachments are in the correct starting position for the exercise to be performed. If there is any slack in the cables or chain as an exercise is performed, the effectiveness of the exercise will be reduced.

## CHANGING THE WEIGHT SETTING

To change the weight setting of the weight stack, insert a Weight Pin (26) under the desired Weight (25). Insert the Weight Pin until the bent end of the Weight Pin is touching the Weights, and turn the bent end downward. The weight setting of the weight stack can be changed from 6.5 pounds to 81.5 pounds, in increments of 12.5 pounds. **Note:** Due to the cables and pulleys, the actual amount of resistance at each exercise station may vary from the weight setting. Use the **WEIGHT RESISTANCE CHART** on page 15 to find the actual amount of resistance at each weight station.

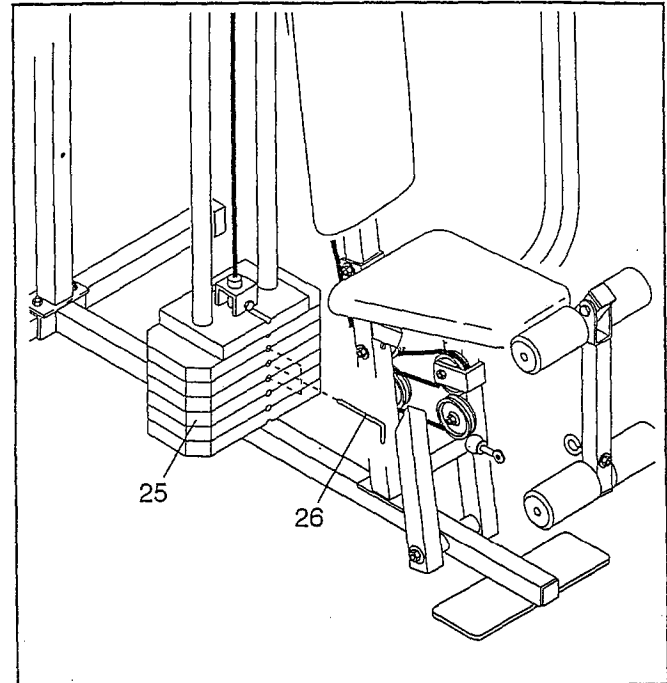

## ATTACHING THE LAT BAR OR NYLON STRAP TO THE HIGH PULLEY STATION

Attach the Lat Bar (54) to the Long Cable (23) with a Cable Clip (53). For some exercises, the Chain (52) should be attached between the Lat Bar and the Long Cable with two Cable Clips. **Adjust the length of the Chain between the Lat Bar and the Long Cable so the Lat Bar is in the correct starting position for the exercise to be performed.**

The Nylon Strap (39) (not shown) can be attached in the same manner.

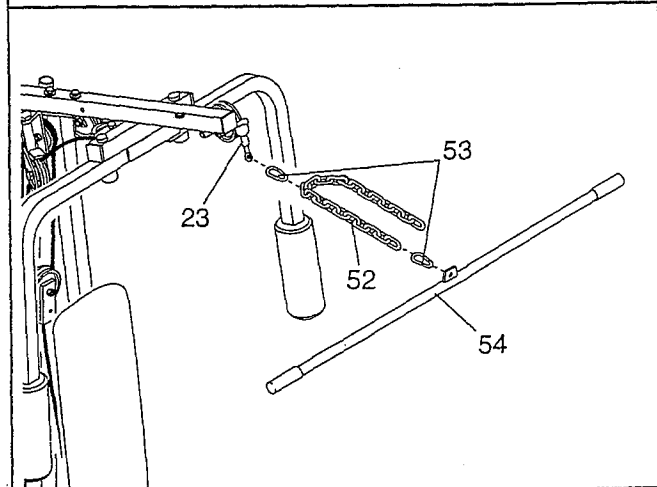

## ATTACHING THE LAT BAR OR NYLON STRAP TO THE LOW PULLEY STATION

Attach the Lat Bar (54) to the Short Cable (58) with a Cable Clip (53). For some exercises, the Chain (52) should be attached between the Lat Bar and the Short Cable with two Cable Clips. **Adjust the length of the Chain between the Lat Bar and the Short Cable so the Lat Bar is in the correct starting position for the exercise to be performed.**

The Nylon Strap (39) (not shown) can be attached in the same manner.

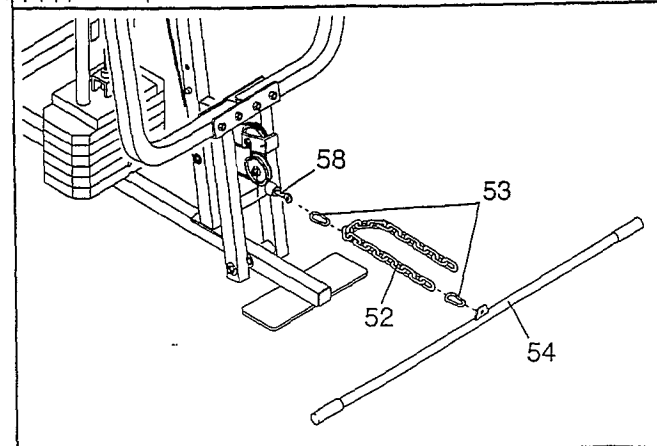

### ATTACHING AND REMOVING THE SEAT

Set the bracket on the Seat Frame (36) onto the indicated pin on the Front Upright (42). Attach the Seat Frame to the Front Upright with the 5/16" x 2 3/4" Carriage Bolt (14) and the Seat Knob (40).

For some exercises, the Seat (13) must be removed. First, be sure that the chain is not attached to the leg lever. Next, remove the Seat Knob (40) and the 5/16" x 2 3/4" Carriage Bolt (14) from the Seat Frame (36). Lift the Seat Frame off the Front Upright (42).

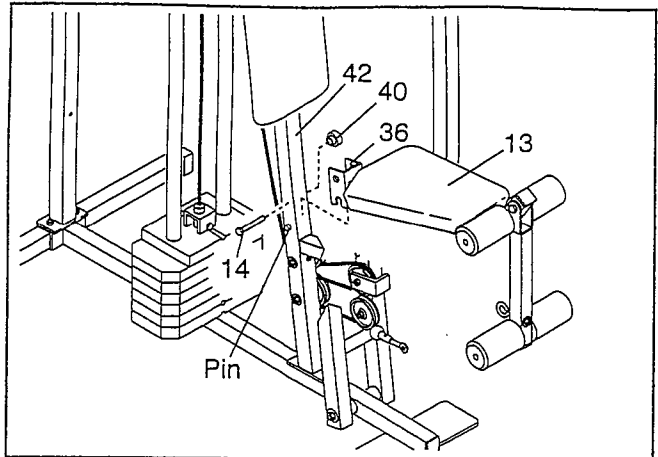

### ATTACHING THE LEG LEVER TO THE LOW PULLEY STATION

To use the Leg Lever (29), the seat must be attached to the front upright (see ATTACHING AND REMOVING THE SEAT above).

Attach one end of the Chain (52) to the Low Cable (23) with a Cable Clip (53). Attach the other end of the Chain to the Eyebolt (35) with a Cable Clip.

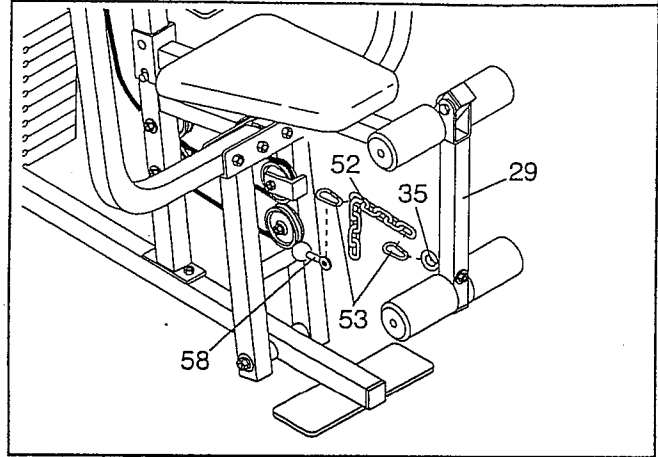

### WEIGHT RESISTANCE CHART

This chart shows the approximate weight resistance at each station. "Top" refers to the 6.5 lb. top weight. The other numbers refer to the 12.5 lb. weight plates. The butterfly arm resistance listed is the resistance for each butterfly arm.

WEIGHT PLATES	PRESS ARM (lbs.)	BUTTERFLY ARM (lbs.)	LEG LEVER (lbs.)	HIGH PULLEY (lbs.)	LOW PULLEY (lbs.)
Top	20	10	15	14	24
1	45	22	36	28	54
2	70	33	54	44	82
3	99	42	75	60	115
4	128	48	96	72	147
5	153	60	115	90	175
6	184	69	137	103	209
	129	96	24	80	84

old version

132191-Weight Resistance Chart

# TROUBLE-SHOOTING AND MAINTENANCE

Inspect and tighten all parts often and replace any worn parts immediately. The home gym system can be cleaned using a damp cloth and mild non-abrasive detergent. Do not use solvents.

## TIGHTENING THE CABLES

Woven cable, the type of cable used on the home gym system, can stretch slightly when it is first used. If there is slack in the cables before resistance is felt, the cables should be tightened. **IMPORTANT: The weight pin must be inserted under the middle weight before tightening the cables.** Slack can be removed from the cables by tightening the 1/4" Nylon Locknuts (2) at the end of the Long Cable (23) (see drawing 1) and at the end of the Short Cable (58) (see drawing 2). To do this you may need to remove the Small "U"-Bracket (67) from the Weight Tube (63) or remove the 3 1/2" Pulley (15) from the Long "U"-Bracket (57). Make sure that the cables are not too tight, or the Top Weight (76) will be lifted off the weight stack.

Additional slack can be removed by moving the 3 1/2" Pulley (15) to the other hole in the Long "U"-Bracket (57) (see drawing 2). Remove the 3/8" Nylon Locknut (21) and the 3/8" x 2" Bolt (12) from the Cable Trap (66), Pulley, and "U"-Bracket. Re-attach the Pulley and Cable Trap. Be sure that the Cable trap is in the proper position and that the Cable and Pulley move smoothly.

**Note: If a cable tends to slip off the pulleys often, the cable may have become twisted. Remove the cable and re-install it.**

If the cables need to be replaced, see ORDERING REPLACEMENT PARTS on the back cover of this manual.

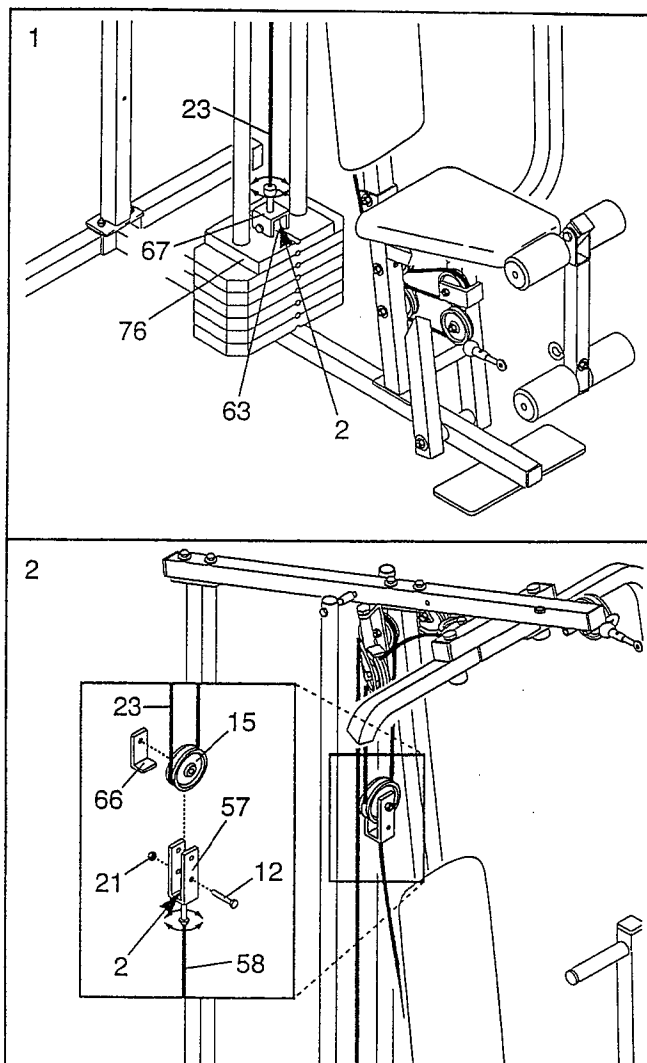



# CABLE DIAGRAM

The cable diagram below shows the proper routing of the Short Cable (58) and the Long Cable (23). Use the diagram to be sure that the two cables have been assembled correctly. If the cables have not been correctly routed, the home gym system will not function properly and damage may occur. The starting and ending points for each cable are labeled. The numbers show the correct route for each cable.

