

SONY®

4-140-272-11(1)

Digital Still Camera Instruction Manual

DSC-W210/W215/W220/W230

Before operating the unit, please read this manual thoroughly, and retain it for future reference.



For details on advanced operations, please read “Cyber-shot Handbook” (PDF) and “Cyber-shot Step-up Guide” on the CD-ROM (supplied) using a computer.



GB

© 2009 Sony Corporation

Cyber-shot

Owner's Record

The model and serial numbers are located on the bottom. Record the serial number in the space provided below. Refer to these numbers whenever you call upon your Sony dealer regarding this product.

Model No. DSC-W210/W215/W220/W230

Serial No. _____

WARNING

To reduce fire or shock hazard, do not expose the unit to rain or moisture.

IMPORTANT SAFETY INSTRUCTIONS

**-SAVE THESE
INSTRUCTIONS**

**DANGER
TO REDUCE THE RISK OF
FIRE OR ELECTRIC
SHOCK, CAREFULLY
FOLLOW THESE
INSTRUCTIONS**

If the shape of the plug does not fit the power outlet, use an attachment plug adaptor of the proper configuration for the power outlet.

CAUTION

Battery pack

If the battery pack is mishandled, the battery pack can burst, cause a fire or even chemical burns. Observe the following cautions.

- Do not disassemble.
- Do not crush and do not expose the battery pack to any shock or force such as hammering, dropping or stepping on it.
- Do not short circuit and do not allow metal objects to come into contact with the battery terminals.
- Do not expose to high temperature above 60°C (140°F) such as in direct sunlight or in a car parked in the sun.
- Do not incinerate or dispose of in fire.
- Do not handle damaged or leaking lithium ion batteries.
- Be sure to charge the battery pack using a genuine Sony battery charger or a device that can charge the battery pack.
- Keep the battery pack out of the reach of small children.
- Keep the battery pack dry.
- Replace only with the same or equivalent type recommended by Sony.
- Dispose of used battery packs promptly as described in the instructions.

Battery charger

Even if the CHARGE lamp is not lit, the battery charger is not disconnected from the AC power source (mains) as long as it is connected to the wall outlet (wall socket). If some trouble occurs while using the battery charger, immediately shut off the power by disconnecting the plug from the wall outlet (wall socket).

For Customers in the U.S.A. and Canada

RECYCLING LITHIUM-ION BATTERIES

Lithium-Ion batteries are recyclable.

You can help preserve our environment by returning your used rechargeable batteries to the collection and recycling location nearest you.



For more information regarding recycling of rechargeable batteries, call toll free 1-800-822-8837, or visit <http://www.rbrc.org/>

Caution: Do not handle damaged or leaking Lithium-Ion batteries.

Battery pack

This device complies with Part 15 of the FCC Rules. Operation is subject to the following two conditions: (1) This device may not cause harmful interference, and (2) this device must accept any interference received, including interference that may cause undesired operation.

This Class B digital apparatus complies with Canadian ICES-003.

For Customers in the U.S.A.

If you have any questions about this product, you may call:

Sony Customer Information Center
1-800-222-SONY (7669)

The number below is for the FCC related matters only.

Regulatory Information

Declaration of Conformity

Trade Name: SONY
Model No.: DSC-W230
Responsible Party: Sony Electronics Inc.
Address: 16530 Via Esprillo,
San Diego, CA 92127U.S.A.
Telephone No.: 858-942-2230

This device complies with Part 15 of the FCC Rules. Operation is subject to the following two conditions: (1) This device may not cause harmful interference, and (2) this device must accept any interference received, including interference that may cause undesired operation.

Declaration of Conformity

Trade Name: SONY
Model No.: DSC-W220
Responsible Party: Sony Electronics Inc.
Address: 16530 Via Esprillo,
San Diego, CA 92127U.S.A.
Telephone No.: 858-942-2230

This device complies with Part 15 of the FCC Rules. Operation is subject to the following two conditions: (1) This device may not cause harmful interference, and (2) this device must accept any interference received, including interference that may cause undesired operation.

Declaration of Conformity

Trade Name: SONY
Model No.: DSC-W210, DSC-W215
Responsible Party: Sony Electronics Inc.
Address: 16530 Via Esprillo,
San Diego, CA 92127U.S.A.
Telephone No.: 858-942-2230

This device complies with Part 15 of the FCC Rules. Operation is subject to the following two conditions: (1) This device may not cause harmful interference, and (2) this device must accept any interference received, including interference that may cause undesired operation.

CAUTION

You are cautioned that any changes or modifications not expressly approved in this manual could void your authority to operate this equipment.

Note:

This equipment has been tested and found to comply with the limits for a Class B digital device, pursuant to Part 15 of the FCC Rules.

These limits are designed to provide reasonable protection against harmful interference in a residential installation. This equipment generates, uses, and can radiate radio frequency energy and, if not installed and used in accordance with the instructions, may cause harmful interference to radio communications. However, there is no guarantee that interference will not occur in a particular installation. If this equipment does cause harmful interference to radio or television reception, which can be determined by turning the equipment off and on, the user is encouraged to try to correct the interference by one or more of the following measures:

- Reorient or relocate the receiving antenna.
- Increase the separation between the equipment and receiver.
- Connect the equipment into an outlet on a circuit different from that to which the receiver is connected.
- Consult the dealer or an experienced radio/TV technician for help.

The supplied interface cable must be used with the equipment in order to comply with the limits for a digital device pursuant to Subpart B of Part 15 of FCC Rules.

For Customers in Europe

Notice for the customers in the countries applying EU Directives

The manufacturer of this product is Sony Corporation, 1-7-1 Konan Minato-ku Tokyo, 108-0075 Japan. The Authorized Representative for EMC and product safety is Sony Deutschland GmbH, Hedelfinger Strasse 61, 70327 Stuttgart, Germany. For any service or guarantee matters please refer to the addresses given in separate service or guarantee documents.

This product has been tested and found compliant with the limits set out in the EMC Directive for using connection cables shorter than 3 meters (9.8 feet).

Attention

The electromagnetic fields at the specific frequencies may influence the picture and sound of this unit.

Notice

If static electricity or electromagnetism causes data transfer to discontinue midway (fail), restart the application or disconnect and connect the communication cable (USB, etc.) again.

Disposal of Old Electrical & Electronic Equipment (Applicable in the European Union and other European countries with separate collection systems)



This symbol on the product or on its packaging indicates that this product shall not be treated as household waste. Instead it shall be handed over to the applicable collection point for the recycling of electrical and electronic equipment. By ensuring this product is disposed of correctly, you will help prevent potential negative consequences for the environment and human health, which could otherwise be caused by inappropriate waste handling of this product. The recycling of materials will help to conserve natural resources. For more detailed information about recycling of this product, please contact your local Civic Office, your household waste disposal service or the shop where you purchased the product.

Disposal of waste batteries (applicable in the European Union and other European countries with separate collection systems)



This symbol on the battery or on the packaging indicates that the battery provided with this product shall not be treated as household waste.

By ensuring these batteries are disposed of correctly, you will help prevent potentially negative consequences for the environment and human health which could otherwise be caused by inappropriate waste handling of the battery. The recycling of the materials will help to conserve natural resources.

In case of products that for safety, performance or data integrity reasons require a permanent connection with an incorporated battery, this battery should be replaced by qualified service staff only. To ensure that the battery will be treated properly, hand over the product at end-of-life to the applicable collection point for the recycling of electrical and electronic equipment.

For all other batteries, please view the section on how to remove the battery from the product safely.

Hand the battery over to the applicable collection point for the recycling of waste batteries.

For more detailed information about recycling of this product or battery, please contact your local Civic Office, your household waste disposal service or the shop where you purchased the product.

Notice for customers in the United Kingdom

A moulded plug complying with BS 1363 is fitted to this equipment for your safety and convenience.

Should the fuse in the plug supplied need to be replaced, a fuse of the same rating as the supplied one and approved by ASTA or BSI to BS 1362, (i.e., marked with an ⚡ or ⚡ mark) must be used.

If the plug supplied with this equipment has a detachable fuse cover, be sure to attach the fuse cover after you change the fuse. Never use the plug without the fuse cover. If you should lose the fuse cover, please contact your nearest Sony service station.

Table of contents

Notes on using the camera	8
Getting started	9
Checking the accessories supplied	9
1 Preparing the battery pack	10
2 Inserting the battery pack/a "Memory Stick Duo" media (sold separately)	11
3 Turning the camera on/setting the clock	13
Shooting images easily	14
Mode dial/Zoom/Flash/Macro/Self-timer/Display	15
Detecting smiles and shooting automatically (Smile Shutter)	17
Detecting the shooting conditions (Scene Recognition)	18
Viewing/deleting images	19
Learning the various functions – HOME/Menu	22
Using the HOME screen	22
HOME items	23
Using menu items	24
Menu items	25
Enjoying your computer	27
Supported Operating Systems for USB connection and application software (supplied)	27
Viewing "Cyber-shot Handbook"	27
Indicators on the screen	28
Battery life and memory capacity	30
Battery life and number of images you can record/view	30
Number of still images and recordable time of movies	31
Troubleshooting	32
Battery pack and power	32
Shooting still images/movies	33
Viewing images	34
Precautions	35
Specifications	36

Notes on using the camera

Internal memory and “Memory Stick Duo” media back up

Do not turn off the camera, remove the battery pack, or remove the “Memory Stick Duo” media while the access lamp is lit. Otherwise, the internal memory data or “Memory Stick Duo” media may be damaged. Be sure to make a backup copy to protect your data.

Notes on recording/playback

- Before you start recording, make a trial recording to make sure that the camera is working correctly.
- The camera is neither dust-proof, nor splash-proof, nor water-proof. Read “Precautions” (page 35) before operating the camera.
- Avoid exposing the camera to water. If water enters inside the camera, a malfunction may occur. In some cases, the camera cannot be repaired.
- Do not aim the camera at the sun or other bright light. It may cause the malfunction of the camera.
- Do not use the camera near a location that generates strong radio waves or emits radiation. Otherwise, the camera may not properly record or play back images.
- Using the camera in sandy or dusty locations may cause malfunctions.
- If moisture condensation occurs, remove it before using the camera (page 35).
- Do not shake or strike the camera. It may cause a malfunction and you may not be able to record images. Furthermore, the recording media may become unusable or image data may be damaged.
- Clean the flash surface before use. The heat of flash emission may cause dirt on the flash surface to become discolored or to stick to the flash surface, resulting in insufficient light emission.

Notes on the LCD screen and lens

- The LCD screen is manufactured using extremely high-precision technology so over 99.99% of the pixels are operational for effective use. However, some tiny black and/or bright dots (white, red, blue or green) may appear on the LCD screen. These dots are a normal result of the manufacturing process, and do not affect the recording.
- When the battery level becomes low, the lens might stop moving. Insert a charged battery pack and turn on the camera again.

On image data compatibility

- The camera conforms with DCF (Design rule for Camera File system) universal standard established by JEITA (Japan Electronics and Information Technology Industries Association).
- Sony does not guarantee that the camera will play back images recorded or edited with other equipment, or that other equipment will play back images recorded with the camera.

On the overheat protection

The power may go off automatically to protect the camera depending on the temperature of the unit or the battery pack. In this case, the message appears on the screen before the power goes off.

Warning on copyright

Television programs, films, videotapes, and other materials may be copyrighted. Unauthorized recording of such materials may be contrary to the provisions of the copyright laws.

No compensation for damaged content or recording failure

Sony cannot compensate for failure to record or loss or damage of recorded content due to a malfunction of the camera or recording media, etc.

Getting started

Checking the accessories supplied

- Battery charger BC-CSGD/BC-CSGE (1)

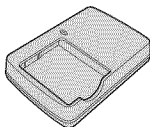

- Power cord (mains lead) (1)
(not supplied in the USA and Canada)

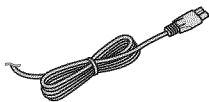

- Rechargeable battery pack NP-BG1 (1)/
Battery case (1)

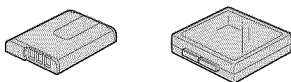

- USB, A/V cable for multi-use terminal (1)

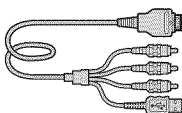

- Wrist strap (1)



- Soft carrying case (1) (DSC-W215 only)

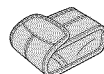

- CD-ROM (1)
 - Cyber-shot application software
 - “Cyber-shot Handbook”
 - “Cyber-shot Step-up Guide”
- Instruction Manual (this manual) (1)

The camera is supplied with a wrist strap.

Attach the strap and place your hand through the loop to prevent the camera from damage by being dropped.

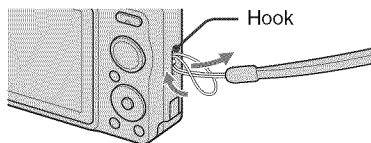

1 Preparing the battery pack

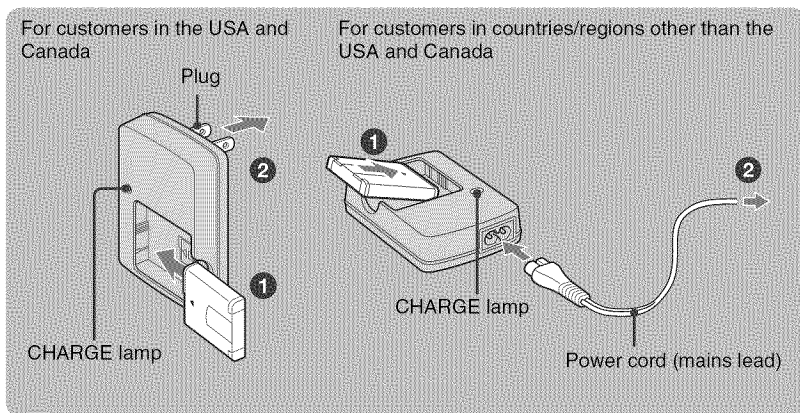

1 Insert the battery pack into the battery charger.

2 Connect the battery charger to the wall outlet (wall socket).

The CHARGE lamp lights up, and charging starts.

When the CHARGE lamp turns off, charging is finished (Normal charge).

If you continue charging the battery pack for about one more hour (until it is fully charged), the charge will last slightly longer.

|| Charging time

Full charge time	Normal charge time
Approx. 330 min.	Approx. 270 min.

- The table above shows the time required to charge a fully depleted battery pack at a temperature of 25°C (77°F). Charging may take longer depending on conditions of use and circumstances.
- See page 30 for the battery life and the number of images that can be recorded.
- Connect the battery charger to the nearest wall outlet (wall socket).
- When charging is finished, disconnect the power cord (mains lead) from the wall outlet (wall socket), and remove the battery pack from the battery charger.
- Be sure to use the battery pack or the battery charger of the genuine Sony brand.

2 Inserting the battery pack/a “Memory Stick Duo” media (sold separately)

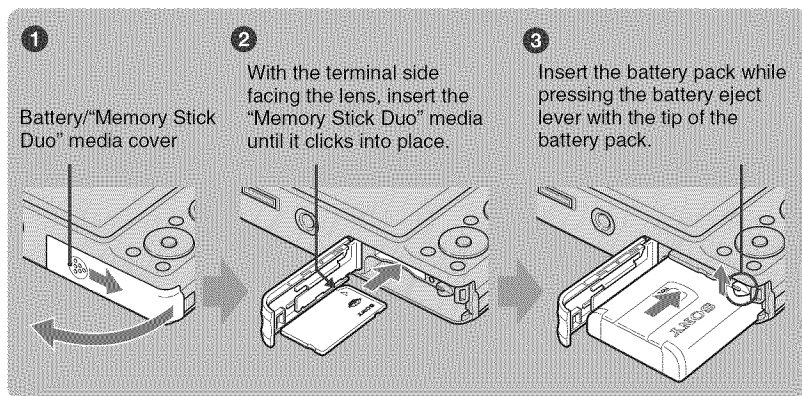

- 1** Open the battery/“Memory Stick Duo” media cover.
- 2** Insert the “Memory Stick Duo” media (sold separately).
- 3** Insert the battery pack.
- 4** Close the battery/“Memory Stick Duo” media cover.

When there is no “Memory Stick Duo” media inserted

The camera records/plays back images using the internal memory (approx. 15 MB).

To check the remaining battery charge

Press ON/OFF (Power) button to turn on and check the remaining battery charge on the LCD screen.

Remaining charge indicator					
Status	Sufficient power remaining	Battery almost fully charged	Battery half full	Battery low, recording/playback will stop soon.	Change the battery with fully charged one, or charge the battery. (The warning indicator flashes.)

- If you use the NP-FG1 battery pack (sold separately), the minutes also appear after the battery remaining indicator (🔋 60 Min).
- It takes about one minute until the correct remaining charge indicator appears.
- The remaining charge indicator may not be correct depending on conditions of use and circumstances.
- Battery capacity decreases over time and through repeated use. When the operating time per charge decreases markedly, the battery pack needs to be replaced. Purchase a new battery pack.

|| To remove the battery pack/“Memory Stick Duo” media

Open the battery/“Memory Stick Duo” media cover.

“Memory Stick Duo” media

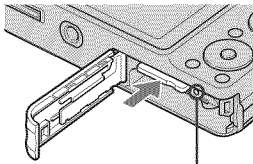

Make sure that **the access lamp** is not lit, then push the “Memory Stick Duo” media in once.

Battery pack

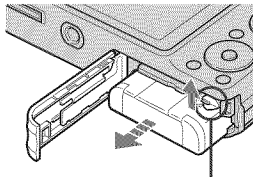

Slide **the battery eject lever**. Be sure not to drop the battery pack.

- Never remove the battery pack/“Memory Stick Duo” media when the access lamp is lit. This may cause damage to data in the “Memory Stick Duo” media/internal memory.

3 Turning the camera on/setting the clock

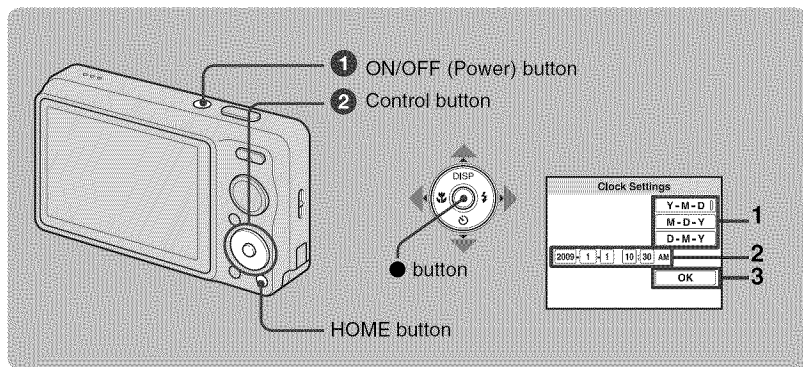

1 Press ON/OFF (Power) button.

2 Set the clock with the control button.

- 1 Select the date display format with ▲/▼, then press ●.
- 2 Select each item with ◀/▶ and set the numeric value with ▲/▼, then press ●.
- 3 Select [OK], then press ●.

- The camera does not have a feature for superimposing dates on images. By using "PMB" in the CD-ROM (supplied), you can print or save images with the date.
- Midnight is indicated as 12:00 AM, and noon as 12:00 PM.

| To change the date and time

Press HOME, and select [⌚ Clock Settings] in  (Settings) (pages 22, 23).

| Notes on when the power is turned on

- Once the battery pack is inserted in the camera, it may take time before operation becomes possible.
- If the camera is running on battery power and you do not operate the camera for about three minutes, the camera turns off automatically to prevent wearing down the battery pack (Auto power-off function).

Shooting images easily

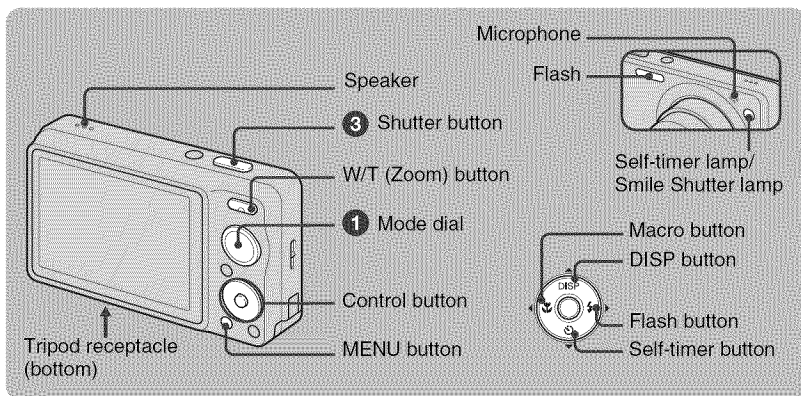

① Select the desired function on the mode dial.

When shooting still images (Auto Adjustment mode): Select .

When shooting movies: Select .

② Hold the camera, with your elbows pressed against your body to steady it.

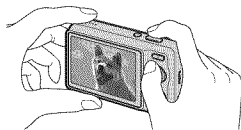

Position the subject in the center of the focus frame. Do not cover the speaker with your finger.

③ Shoot with the shutter button.

When shooting still images:

1 Press and hold the shutter button halfway down to focus.

The ● (AE/AF lock) indicator (green) flashes, a beep sounds, the indicator stops flashing and remains lit.

2 Press the shutter button fully down.



AE/AF lock indicator

When shooting movies:

Press the shutter button fully down.

To stop recording, press the shutter button fully down again.

• The shortest shooting distance is approx. 4 cm (1 5/8 inches) (W)/50 cm (1 foot 7 3/4 inches) (T) (from the lens).

Mode dial/Zoom/Flash/Macro/Self-timer/Display

Using the mode dial

Auto Adjustment

Allows you to shoot with the settings adjusted automatically.

EASY Easy Shooting

Allows easy shooting with easy-to-see indicators.

Smile Shutter

When the camera detects a smile, the shutter is released automatically (page 17).

High Sensitivity (DSC-W220/W230 only)

Shoots images without a flash even in low lighting.

SteadyShot (DSC-W210/W215 only)

Shoots images clearly, reducing blur.

Soft Snap

Shoots images with a softer atmosphere for portraits of people, flowers, etc.

Landscape

Shoots with the focus on a distant subject.

Twilight Portrait

Shoots sharp images of people in a dark place without losing the nighttime atmosphere.

SCN* Scene Selection

Selects a setting from the Scene Selection menu.

Movie Mode

Allows you to record movies with audio.

P Program Auto

Allows you to shoot with the exposure adjusted automatically (both the shutter speed and the aperture value). You can adjust other settings using the menu.

* Scene Selection in SCN mode

Press MENU and select a setting (page 24).

High Sensitivity (DSC-W210/W215 only)

Shoots images without a flash even in low lighting.

Twilight

Shoots night scenes without losing the nighttime atmosphere.

Gourmet

Shifts to Macro mode, allowing you to shoot food arrangements in delicious color.

Beach

Shoots seaside or lakeside scenes with the blueness of the water captured more vividly.

Snow

Shoots snow scenes in white more clearly.

Fireworks

Shoots fireworks in all their splendor.

Underwater

Shoots underwater in natural colors when the water-proof case is attached.

|| W/T Using the zoom

Press T to zoom, press W to return the zoom.

|| ⚡ Flash (Selecting a flash mode for still images)

Press  (⚡) on the control button repeatedly until the desired mode is selected.

AUTO: Flash Auto



Flashes when there is insufficient light or backlight (default setting)

: Flash forced on

SL: Slow synchro (Flash forced on)

The shutter speed is slow in a dark place to clearly shoot the background that is out of flash light.

: Flash forced off

- You cannot use  (Flash forced on) or SL (Slow synchro) when [Scene Recognition] is set to [Auto] or [Advanced].
- Even with flash on, the flash may not operate during burst.

|| 🌸 Macro (Shooting close-up)

Press  (🌸) on the control button repeatedly until the desired mode is selected.

AUTO: Auto

The camera adjusts the focus automatically from distant subjects to close-up.
Normally, put the camera in this mode.

: Macro On

The camera adjusts the focus with priority on close-up subjects. Set Macro on when shooting close subjects.

|| ⌚ Using the self-timer

Press  (⌚) on the control button repeatedly until the desired mode is selected.

OFF: Not using the self-timer

10: Setting the 10-second delay self-timer

Use this setting if you want to include yourself in the image.

2: Setting the 2-second delay self-timer

This is to prevent blurring due to unsteadiness when the shutter button is pressed.

When you press the shutter button, the self-timer lamp flashes and a beep sounds until the shutter operates.

To cancel, press  (⌚) again.

|| DISP Changing the screen display

Press  (DISP) on the control button.

Each time you press  (DISP), the display and brightness changes as follows:

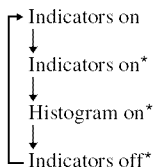

* The LCD Backlight brightens.

Detecting smiles and shooting automatically (Smile Shutter)

When the camera detects a smile, the shutter is released automatically.

- 1 Select ☺ (Smile Shutter) mode on the mode dial.
- 2 Aim the camera at the subject and press the shutter button halfway down to focus.
- 3 Press the shutter button all the way down to set Smile Detection mode.

The Smile Shutter enters standby.

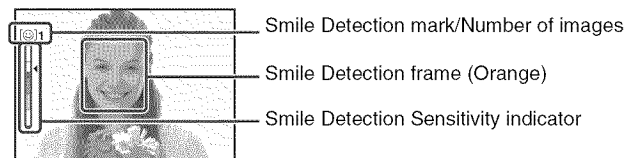

- 4 Wait detecting a smile.

When the smile level exceeds the ◀ point on the indicator, the camera records up to six images. Press the shutter button all the way down again to exit the Smile Shutter mode.

- Shooting using the Smile Shutter ends automatically when either the "Memory Stick Duo" media or internal memory becomes full or when six images have been recorded.
- Smiles may not be detected correctly depending on the conditions.



💡 Hints for better capturing of smiles



- ① Do not cover the eyes with the bangs.
- ② Try to orient the face in front of the camera and be as level as possible. The detection rate is higher when the eyes are narrowed.
- ③ Give a clear smile with an open mouth. The smile is easier to detect when the teeth are showing.

Detecting the shooting conditions (Scene Recognition)

The camera automatically detects the shooting conditions, and then takes the shot.

- 1 Select  (Auto Adjustment) mode on the mode dial.
- 2 Press MENU button (pages 24, 25).
- 3 Select  (Scene Recognition) with ▲/▼ on the control button.
- 4 Select the desired setting, then press ●.

 : Off (Default setting)

Does not use Scene Recognition.

 : Auto

When the camera recognizes the scene, it switches to the optimal settings and shoots the image.

 : Advanced

The camera shoots one image without using the scene recognition function and another image using scene recognition. (A total of two shots)





- Scene recognition does not function in the following situations:
 - During burst shooting
 - When using Digital Zoom

 When the camera recognizes the scene



Setting value icon

Scene Recognition icon

When the camera recognizes the scene,  (Twilight),  (Twilight Portrait),  (Twilight using a tripod) (DSC-W220/W230 only),  (Backlight),  (Backlight Portrait) appears.

When the camera does not recognize the scene, the image is shot as Scene Recognition [Off].

Viewing/deleting images

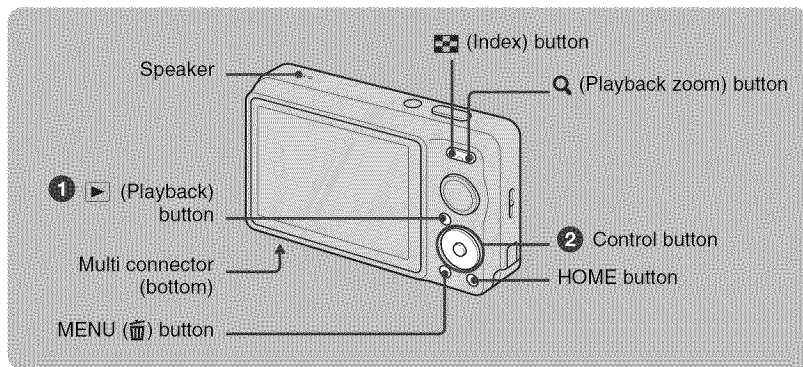

1 Press (Playback).

If you press when the camera is powered off, the camera is turned on automatically and set to playback mode. To switch to the shooting mode, press again.

2 Select an image with / on the control button.

Movie:

Press to play back a movie. (Press again to stop playback.)

Press to fast forward, to rewind. (Press to return to normal playback.)

Press to display the volume control screen, then press / to adjust the volume.

To delete images

1 Display the image you want to delete, then press MENU ().

2 Select [Delete] with / and select [This Image] with / , then press .

3 Select [OK] with , then press .

To view an enlarged image (playback zoom)

Press (T) while displaying a still image.

To return the zoom, press .

Adjust the position with / / / .

To cancel the playback zoom, press .





Shows the displayed area of the whole image

|| To view an index screen

Press  (Index) while a single image is displayed.







Then, select an image with ///.





To return to the single image screen, press .

- Each time you press , the number of images on the index screen increases.

|| To delete images in index mode

1 Press MENU while the index screen is displayed.

2 Select  (Delete) with / and select [Multiple Images] with /, then press .

3 Select the image you want to delete with ///, then press .

The  mark is checked in the checkbox of the image.





To cancel a selection, select an image you have selected for deletion, then press  again.

4 Press MENU and select [OK] with , then press .

- To delete all the images in a folder, select [All In This Folder], then press  in step 2.

|| To play back a series of images with effects and music (Slideshow)

1 Press MENU button.

2 Select  (Slideshow) with / on the control button, then press .

The Setup screen appears.



3 Select [OK], then press .

The slideshow starts.

The music will change together with the [Effects]. You can also transfer and change the music to your desired music.

To transfer and change the music, take the following steps.

① Install the software included in the CD-ROM (supplied) to your computer.

② Press HOME button. Then select [ Music Tool] → [Download Music] in [ Slideshow] (pages 22, 23).

③ Connect the camera and a computer with cable for multi-use terminal.

④ Start up "Music Transfer" installed to your computer and change the music.

For details on changing the music, refer to Help in "Music Transfer".

I To view images on TV

Connect the camera to the TV with the cable for multi-use terminal (supplied).

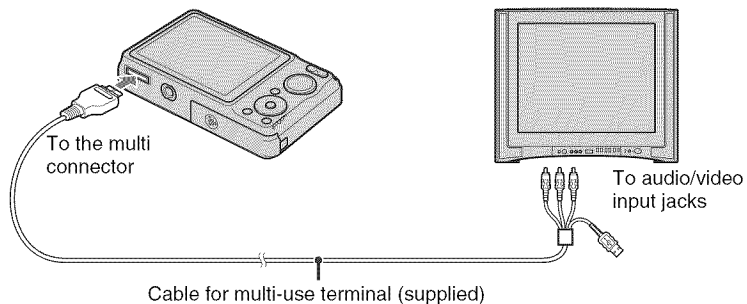

To view on HD (High Definition) TV, an HD Output Adaptor Cable (sold separately) is needed.

- If you set the image size to [16:9], you can record images in the size that fills the entire screen of the HD TV.
- You cannot view movies output in [HD(1080i)] signal format. Set [COMPONENT] to [SD] when shooting movies.
- Use a Type2b-compliant HD Output Adaptor Cable.

Learning the various functions – HOME/Menu

Using the HOME screen

The HOME screen is the gateway screen for all the functions of the camera, and can be called up regardless of the mode setting (shooting/viewing).

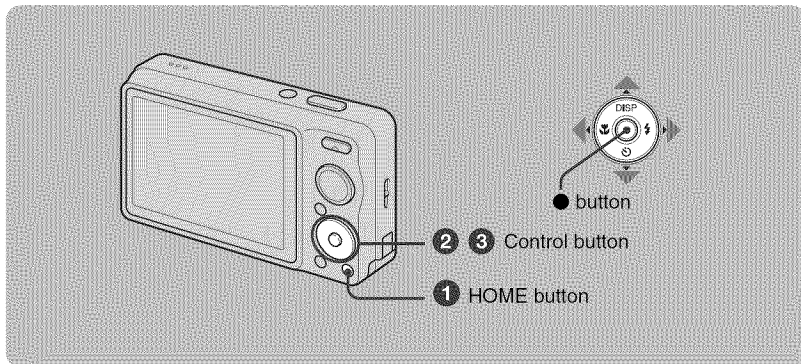

1 Press HOME to display the HOME screen.

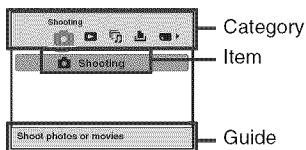

2 Select a category with \leftarrow/\rightarrow on the control button.

3 Select an item with \uparrow/\downarrow , then press \bullet .

|| When you select the [Memory] (Manage Memory) or [Settings] (Settings) category

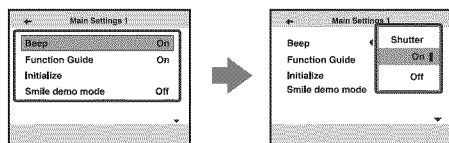

1 Select the desired setting with \uparrow/\downarrow , then press \bullet .







• HOME screen is displayed by pressing \leftarrow .

2 Select a setting with \uparrow/\downarrow , then press \bullet .

• The camera is set to the shooting or viewing mode by pressing HOME again.

HOME items

Pressing HOME displays the following items. Only the available items are displayed on the screen. Details on the items are displayed on the screen by the guide.

Categories	Items
 Shooting	Shooting
 View Images	Single Image Image Index
 Slideshow	Slideshow Music Tool Download Music Format Music
 Print	Print
 Manage Memory	Memory Tool Memory Stick Tool Format Create REC.Folder Change REC.Folder Copy Internal Memory Tool Format
 Settings	Main Settings Main Settings 1 Beep Function Guide Initialize Smile demo mode Main Settings 2 USB Connect COMPONENT Video Out Wide Zoom Display Shooting Settings Shooting Settings 1 AF Illuminator Grid Line AF Mode Digital Zoom Conversion Lens Shooting Settings 2 Auto Orientation* Auto Review Clock Settings Language Setting

* DSC-W220/W230 only.

Using menu items

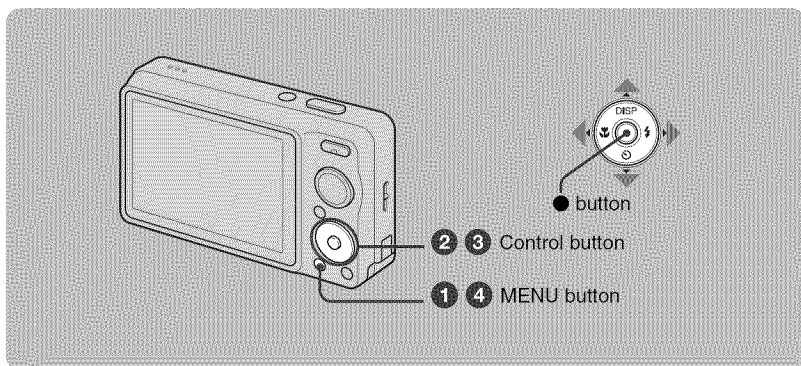

- 1 Press MENU to display the menu.

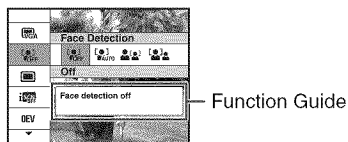

- The menu will be displayed only during shooting and playback mode.
- Different items will become visible depending on the selected mode.

- 2 Select a desired menu item with ▲/▼ on the control button.

- If the desired item is hidden, keep pressing ▲/▼ until the item appears on the screen.

- 3 Select a setting with ◀/▶.

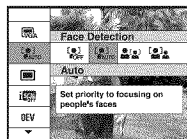

- If the desired item is hidden, keep pressing ◀/▶ until the item appears on the screen.
- Select an item in playback mode, and press ●.

- 4 Press MENU to turn off the menu.









Menu items

The available menu items vary depending on the mode setting (shooting/viewing), and the mode dial position in the shooting mode. Only the available items are displayed on the screen.

Shooting menu

Scene Selection	Selects the settings pre-adjusted to match various scene conditions.
Image Size	Selects the image size.
Flash	Selects the flash setting in Easy Shooting mode.
Face Detection	Selects the priority subject for adjusting the focus when using face detection.
Smile Detection	Selects the priority subject for the Smile Shutter function.
Smile Detection Sensitivity	Sets the level of sensitivity to detect smile.
REC Mode	Selects the continuous shooting method.
Scene Recognition	Automatically detects the shooting conditions such as backlight and Twilight and then takes the shot.
EV	Adjusts Exposure.
ISO	Selects a luminous sensitivity.
Metering Mode	Selects the metering mode.
Focus	Changes the focus method.
White Balance	Adjusts the color tones.
Underwater White Balance	Adjusts the color tones underwater.
Flash Level	Adjusts the amount of flash light.
Red Eye Reduction	Sets to reduce the red-eye phenomenon.
DRO	Optimizes the brightness and contrast.
Color Mode	Changes the vividness of the image or adds special effects.
SteadyShot (DSC-W220/W230 only)	Selects the anti-blur mode.
 Shooting Settings	Selects the shooting settings.

Viewing menu

 (Delete)	Deletes images.
 (Slideshow)	Plays back a series of images with effects and music.
 (Retouch)	Retouches still images.
 (Multi-Purpose Resize)	Changes the image size according to usage.
 (Protect)	Prevents accidental erasure.
DPOF	Adds a Print order mark on image that you want to print out.
 (Print)	Prints images using a PictBridge compliant printer.
 (Rotate)	Rotates a still image.
 (Select Folder)	Selects the folder for viewing images.

Enjoying your computer

You can view images shot with the camera on a computer. By using the software in the CD-ROM (supplied), you can enjoy still images and movies from the camera more than ever. For details, refer to “Cyber-shot Handbook” in the CD-ROM (supplied).

Supported Operating Systems for USB connection and application software (supplied)

	For Windows users	For Macintosh users
USB connection	Microsoft Windows 2000 Professional SP4/Windows XP* ¹ SP3/Windows Vista* ² SP1	Mac OS 9.1/9.2/ Mac OS X(v10.1 to v10.5)
Application software “PMB”	Microsoft Windows XP* ¹ SP3/ Windows Vista* ² SP1	not compatible

*¹ 64-bit editions are not supported.

*² Starter (Edition) is not supported.

- Your computer must be pre-installed with an OS listed above. OS upgrades are not supported.
- If your OS does not support USB connections, copy images by inserting the “Memory Stick Duo” media into the “Memory Stick” media slot on your computer, or use a commercially available “Memory Stick” media Reader/Writer.
- For further details on the operating environment of “PMB” Cyber-shot application software, refer to “Cyber-shot Handbook”.



Viewing “Cyber-shot Handbook”

“Cyber-shot Handbook” in the CD-ROM (supplied) explains how to use the camera in detail. Adobe Reader is required to view it.

For Windows users

- 1 Turn on your computer, and insert the CD-ROM (supplied) into the CD-ROM drive.
The installation menu screen appears.
- 2 Click the [Cyber-shot Handbook] button.
 - When you install “Cyber-shot Handbook”, the “Cyber-shot Step-up Guide” will be installed automatically.
- 3 After the installation is complete, double-click the shortcut created on the desktop.

For Macintosh users

- 1 Turn on your computer, and insert the CD-ROM (supplied) into the CD-ROM drive.
- 2 Select the [Handbook] folder and copy “Handbook.pdf” stored in the [GB] folder to your computer.
- 3 After copying is complete, double-click “Handbook.pdf”.

Indicators on the screen

Each time you press ▲ (DISP) on the control button, the display changes (page 16).

When shooting still images

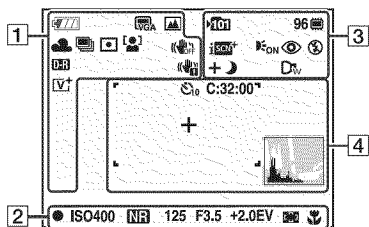

- The indicators are limited in Easy Shooting mode.

When shooting movies

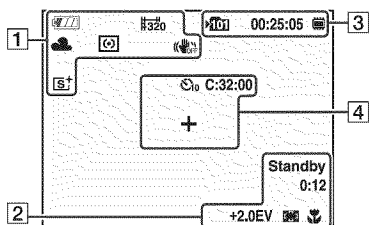

When playing back

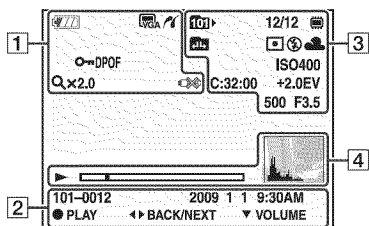

1

	Battery remaining
	Low battery warning
	Image Size
	Mode dial/Menu (Scene Selection) • (hand) (SteadyShot) mode is available only for DSC-W210/W215.
	Mode dial (Program Auto)
	White balance
	Burst mode/Bracket mode
	Metering mode
	Face Detection/Smile Detection
	SteadyShot (DSC-W220/W230 only)
	DRO
	Vibration warning
	Smile Detection Sensitivity indicator/Number of images
	Zoom scaling
	Color mode
	PictBridge connecting
	Protect
	Print order (DPOF) mark

Qx2.0	Zoom scaling
VOL. ■■■■■■	Volume
	PictBridge connecting

2

	AE/AF lock
ISO400	ISO number
NR	NR slow shutter
125	Shutter speed
F3.5	Aperture value
+2.0EV	Exposure value
	AF range finder frame indicator
1.0m	Semi manual value
	Macro
REC Standby	Recording a movie/Standby a movie
0:12	Recording time (minutes : seconds)
101-0012	Folder-file number
2009 11 9:30 AM	Recorded date/time of the playback image
● STOP ● PLAY	Function guide for playing image
BACK/NEXT	Selecting images
VOLUME	Adjusting volume

3

f01	Recording folder
f01	Playback folder
96	Number of recordable images
8/8 12/12	Image number/Number of images recorded in selected folder
	Recording/playback Media ("Memory Stick Duo" media, Internal memory)

00:25:05	Recordable time (hours : minutes : seconds)
	Changing folder
iSCN iSCN+ 	Scene Recognition
	AF illuminator
	Red-eye reduction
	Metering mode
	Flash mode
	Flash charging
AWB	White balance
C:32:00	Self-diagnosis display
ISO400	ISO number
+2.0EV	Exposure Value
500	Shutter speed
F3.5	Aperture value
D₁ D_w	Conversion lens

4

0 2	Self-timer
C:32:00	Self-diagnosis display
	AF range finder frame
	Playback
	Playback bar
	Spot metering cross hair
	Histogram <ul style="list-style-type: none"> appears when histogram display is disabled.

Battery life and memory capacity

Battery life and number of images you can record/view

The numbers shown in the following tables assume a fully charged battery pack (supplied) is used at an ambient temperature of 25°C (77°F). The numbers shown for images you can record/view are approximations and allow for changing of the “Memory Stick Duo” media as necessary.

Note that the actual numbers may be less than those indicated in the table depending on the conditions of use.

When shooting still images

Battery life (min.)	No. of Images
DSC-W230	
Approx. 175	Approx. 350
DSC-W220	
Approx. 185	Approx. 370
DSC-W210/W215	
Approx. 215	Approx. 430

- Shooting in the following situations:
 - [REC Mode] is set to [Normal].
 - [AF Mode] is set to [Single].
 - [SteadyShot] is set to [Shooting] (DSC-W220/W230 only).
 - Shooting once every 30 seconds.
 - The zoom is switched alternately between the W and T ends.
 - The flash strobes once every two times.
 - The power turns on and off once every ten times.
- The measurement method is based on the CIPA standard.
(CIPA: Camera & Imaging Products Association)
- The battery life and the number of images do not change, regardless of image size.

When viewing still images

Battery life (min.)	No. of Images
DSC-W230	
Approx. 360	Approx. 7200
DSC-W220	
Approx. 420	Approx. 8400
DSC-W210/W215	
Approx. 470	Approx. 9400

- Viewing single images in order at about three second intervals

Notes on the battery pack

- Battery capacity decreases over time and through repeated use.
- The battery life and the number of images you can record/view are decreased under the following conditions:
 - The surrounding temperature is low.
 - The flash is used frequently.
 - The camera has been turned on and off many times.
 - The zoom is used frequently.
 - The LCD Backlight brightens.
 - [AF Mode] is set to [Monitor].
 - [SteadyShot] is set to [Continuous] (DSC-W220/W230 only).
 - The battery power is low.
 - The Face Detection function is activated.

Number of still images and recordable time of movies

The number of still images and the length of time for movies may vary depending on the shooting conditions.

- Even if the capacity of your recording media is the same as the one in the table below, the number of still images and the length of time for movies may be different.
- You can select the image size from the menu (pages 24, 25).

The approximate recordable number of still images

(Units: Images)

Capacity Size	Internal memory	"Memory Stick Duo" media formatted with the camera						
	Approx. 15 MB	256 MB	512 MB	1 GB	2 GB	4 GB	8 GB	16 GB
12M	3	48	100	204	412	815	1638	3321
8M	4	72	150	306	618	1223	2457	4981
5M	6	92	191	390	787	1557	3127	6340
3M	10	148	306	626	1262	2498	5017	10170
VGA	96	1428	2941	6013	12120	23980	48160	97640
3:2(11M)	3	54	112	229	462	915	1838	3726
16:9(9M)	3	58	120	246	496	982	1974	4001
16:9(2M)	16	238	490	1002	2020	3997	8027	16270

- The numbers of images listed assume [REC Mode] is set to [Normal].
- When the number of remaining shootable images is greater than 9,999, the ">9999" indicator appears.
- When an image was recorded using an earlier Sony model and is played back on the camera, the image may not appear in the actual image size.

The approximate recordable time of movies

The numbers in the table below show the approximate maximum recordable time obtained by totaling all movie files.

(Units: hour : minute : second)

Capacity Size	Internal memory	"Memory Stick Duo" media formatted with the camera						
	Approx. 15 MB	256 MB	512 MB	1 GB	2 GB	4 GB	8 GB	16 GB
640(Fine)	–	0:02:50	0:06:00	0:12:30	0:25:10	0:49:50	1:40:20	3:23:20
640(Standard)	0:00:40	0:10:40	0:22:00	0:45:00	1:30:50	2:59:50	6:01:10	12:12:20
320	0:02:50	0:42:50	1:28:10	3:00:20	6:03:30	11:59:30	24:04:50	48:49:20

- Movies with the size set to [640(Fine)] can only be recorded on a "Memory Stick PRO Duo" media.
- The camera does not support HD recordings or playbacks for movies.
- The size of a movie file is limited to approx. 2 GB. During recording, movie recording stops automatically when the file size of the movie reaches approx. 2 GB.

Troubleshooting

If you experience trouble with the camera, try the following solutions.

1 Check the items below, and refer to “Cyber-shot Handbook” (PDF).

If a code such as “C/E:□□:□□” appears on the screen, refer to “Cyber-shot Handbook”.

2 Remove the battery pack, wait for about one minute, reinsert the battery pack, then turn on the power.

3 Initialize the settings (page 23).

4 Consult your Sony dealer or local authorized Sony service facility.

Be aware that by sending the camera for repair, you give consent that the contents of the internal memory, music files may be checked.

Battery pack and power

Cannot insert the battery pack.

- Insert the battery pack correctly by pushing the battery eject lever (page 11).

Cannot turn on the camera.

- After inserting the battery pack into the camera, it may take a few moments for the camera to power up.
- Insert the battery pack correctly (page 11).
- The battery pack is discharged. Insert charged battery pack (page 10).
- The battery pack is dead. Replace it with a new one.
- Use a recommended battery pack.

The power turns off suddenly.

- If you do not operate the camera for about three minutes while the power is on, the camera turns off automatically to prevent wearing down the battery pack. Turn on the camera again (page 13).
- The battery pack is dead. Replace it with a new one.
- Depending on the temperature of the camera and the battery pack, the power may turn off automatically to protect the camera. In this case, a message appears on the LCD screen before the camera turns off.

The remaining charge indicator is incorrect.

- This phenomenon occurs when you use the camera in an extremely hot or cold location.
- A discrepancy arose between the remaining charge indicator and the actual remaining battery charge. Fully discharge the battery pack once, then charge it to correct the indication.
- The battery pack is discharged. Insert the charged battery pack (page 10).
- The battery pack is dead. Replace it with a new one.

The CHARGE lamp flashes while charging the battery.



- Remove and reinsert the battery pack, making sure it is installed correctly.
- The temperature may be inappropriate for charging. Try charging the battery pack again within the proper charging temperature range (10°C to 30°C).

Cannot charge the battery pack.

- You cannot charge the battery pack using the AC Adaptor (sold separately). Use the battery charger to charge the battery.

Shooting still images/movies

Cannot record images.

- Check the free capacity of the internal memory or “Memory Stick Duo” media (page 31). If it is full, do one of the following:
 - Delete unnecessary images (page 19).
 - Change the “Memory Stick Duo” media.
- You cannot record images while charging the flash.
- When shooting a still image, set the mode dial to a position other than .
- Set the mode dial to  when shooting movies.
- The image size is set to [640(Fine)] when recording movies. Do one of the following:
 - Set the image size to other than [640(Fine)].
 - Insert a “Memory Stick PRO Duo” media.

Cannot shoot in Smile Shutter mode.

- Press the shutter button all the way down.
- No image is shot unless a smile is detected (page 17).
- [Smile demo mode] is set to [On]. Set [Smile demo mode] to [Off] (page 23).

White, black, red, purple or other streaks appear on the image, or the image seems reddish.

- This phenomenon is called smearing. This is not a malfunction.

The same image is shot several times.

- [REC Mode] is set to [Burst] or Exposure Bracket. Or, [Scene Recognition] is set to [Advanced] (page 25).

Viewing images

Cannot play back images.

- Press  (Playback) (page 19).
- The folder/file name has been changed on your computer.
- Sony does not guarantee playback of image files on the camera if the files have been processed using a computer or recorded with another camera.
- The camera is in USB mode. Delete the USB connection.
- Playback is impossible if the Smile Shutter is in standby mode. Exit standby mode by pressing the shutter button all the way down.

Precautions

Do not use/store the camera in the following places

- In an extremely hot, cold or humid place
In places such as in a car parked in the sun, the camera body may become deformed and this may cause a malfunction.
- Under direct sunlight or near a heater
The camera body may become discolored or deformed, and this may cause a malfunction.
- In a location subject to rocking vibration
- Near strong magnetic place
- In sandy or dusty places
Be careful not to let sand or dust get into the camera. This may cause the camera to malfunction, and in some cases this malfunction cannot be repaired.

On carrying

Do not sit down in a chair or other place with the camera in the back pocket of your trousers or skirt, as this may cause malfunction or damage the camera.

On the battery pack

- Avoid rough handling, disassembling, modifying, physical shock, or impact such as hammering, dropping or stepping on the battery pack.
- Do not use a deformed or damaged battery pack.

On cleaning

Cleaning the LCD screen

Wipe the screen surface with an LCD cleaning kit (sold separately) to remove fingerprints, dust, etc.

Cleaning the lens

Wipe the lens with a soft cloth to remove fingerprints, dust, etc.

Cleaning the camera surface

Clean the camera surface with a soft cloth slightly moistened with water, then wipe the surface with a dry cloth. To prevent damage to the finish or casing:

- Do not expose the camera to chemical products such as thinner, benzine, alcohol, disposable cloths, insect repellent, sunscreen or insecticide.
- Do not touch the camera with any of the above on your hand.
- Do not leave the camera in contact with rubber or vinyl for a long time.

On operating temperatures

The camera is designed for use under the temperatures between 0°C and 40°C (32°F and 104°F). Shooting in extremely cold or hot places that exceed this range is not recommended.

On camera's temperature

Your camera and battery may get warm due to continuous use, but it is not a malfunction.

On moisture condensation

If the camera is brought directly from a cold to a warm location, moisture may condense inside or outside the camera. This moisture condensation may cause a malfunction of the camera.

If moisture condensation occurs

Turn off the camera and wait about an hour for the moisture to evaporate. Note that if you shoot with moisture remaining inside the lens, images will not be clear.

On the internal rechargeable backup battery

The camera has an internal rechargeable battery for maintaining the date and time and other settings regardless of whether the power is on or off.

This rechargeable battery is continually charged as long as you are using the camera. However, if you use the camera for only short periods, it discharges gradually, and if you do not use the camera at all for about one month it becomes completely discharged. In this case, be sure to charge this rechargeable battery before using the camera.

However, even if this rechargeable battery is not charged, you can still use the camera, but the date and time will not be indicated.

Charging method of the internal rechargeable backup battery

Insert charged battery pack in the camera, and then leave the camera for 24 hours or more with the power off.

Specifications

Camera

[System]

Image device:

7.79 mm (1/2.3 type) color CCD, Primary color filter

Total pixel number of camera:

Approx. 12.4 Megapixels

Effective pixel number of camera:

Approx. 12.1 Megapixels

Lens: Carl Zeiss Vario-Tessar 4× zoom lens

f = 5.35 – 21.4 mm (30 – 120 mm (35 mm film equivalent)) F2.8 (W) – F5.8 (T)

Exposure control:

DSC-W220/W230

Automatic exposure, Scene Selection (11 modes)

DSC-W210/W215

Automatic exposure, Scene Selection (12 modes)

White balance: Automatic, Daylight, Cloudy,

Fluorescent 1,2,3, Incandescent, Flash

Underwater White Balance: Auto, Underwater

1,2, Flash

File format (DCF compliant):

Still images: Exif Ver. 2.21 JPEG compliant, DPOF compatible

Movies: MPEG1 compliant (Monaural)

Recording media: Internal Memory (approx.

15 MB), "Memory Stick Duo" media

Flash: Flash range (ISO sensitivity

(Recommended exposure Index) set to Auto):

Approx. 0.2 to 3.9 m (7 7/8 inches to 12 feet 9 5/8 inches) (W)/approx. 0.5 to 1.9 m (1 foot 7 3/4 inches to 6 feet 2 7/8 inches) (T)

[Input and Output connectors]

Multi use terminal Type2b (AV-out(SD/HD

Component)/USB/DC-in):

Video output

Audio output (Monaural)

USB communication

USB communication: Hi-Speed USB (USB 2.0 compliant)

[LCD screen]

LCD panel:

DSC-W230

7.5 cm (3.0 type)

TFT drive

DSC-W210/W215/W220

6.7 cm (2.7 type)

TFT drive

Total number of dots: 230 400 (960 × 240) dots

[Power, general]

Power: Rechargeable battery pack

NP-BG1, 3.6 V

NP-FG1 (sold separately), 3.6 V

AC-LS5K AC Adaptor (sold separately), 4.2 V

Power consumption (during shooting):

DSC-W230

1.1 W

DSC-W220

1.0 W

DSC-W210/W215

0.9 W

Operating temperature: 0°C to 40°C (32°F to 104°F)

Storage temperature: -20°C to +60°C (-4°F to +140°F)

Dimensions:

95.2 × 56.5 × 21.8 mm (3 3/4 × 2 1/4 × 7/8 inches) (W/H/D, excluding protrusions)

Mass:

DSC-W230

Approx. 156 g (5.5 oz) (including NP-BG1 battery pack, "Memory Stick Duo" media)

DSC-W220

Approx. 147 g (5.2 oz) (including NP-BG1 battery pack, "Memory Stick Duo" media)

DSC-W210/W215

Approx. 146 g (5.1 oz) (including NP-BG1 battery pack, "Memory Stick Duo" media)

Microphone: Monaural

Speaker: Monaural

Exif Print: Compatible

PRINT Image Matching III: Compatible

PictBridge: Compatible

BC-CSGD/BC-CSGE battery charger

Power requirements: AC 100 V to 240 V, 50/60 Hz, 2 W

Output voltage: DC 4.2 V, 0.25 A

Operating temperature: 0°C to 40°C (32°F to 104°F)

Storage temperature: -20°C to +60°C (-4°F to +140°F)

Dimensions: Approx. 83 × 55 × 24 mm (3 3/8 × 2 1/4 × 31/32 inches) (W/H/D)

Mass: Approx. 55 g (1.9 oz)

Rechargeable battery pack NP-BG1

Used battery: Lithium-ion battery

Maximum voltage: DC 4.2 V

Nominal voltage: DC 3.6 V

Maximum charge current: 1.44 A

Maximum charge voltage: DC 4.2 V

Capacity:

typical: 3.4 Wh (960 mAh)

minimum: 3.3 Wh (910 mAh)

Design and specifications are subject to change without notice.

Trademarks

- The following marks are trademarks of Sony Corporation.
Cyber-shot, “Cyber-shot,” “Memory Stick,”  “Memory Stick PRO,” **MEMORY STICK PRO**, “Memory Stick Duo,” **MEMORY STICK DUO**, “Memory Stick PRO Duo,” **MEMORY STICK PRO DUO**, “Memory Stick PRO-HG Duo,” **MEMORY STICK PRO-HG DUO**, “Memory Stick Micro,” “MagicGate,” **MAGICGATE**, “PhotoTV HD,” “Info LITHIUM”
- Microsoft, Windows, DirectX and Windows Vista are either registered trademarks or trademarks of Microsoft Corporation in the United States and/or other countries.
- Macintosh, Mac OS, iMac, iBook, PowerBook, Power Mac and eMac are trademarks or registered trademarks of Apple Inc.
- Intel, MMX, and Pentium are trademarks or registered trademarks of Intel Corporation.
- Adobe and Reader are either registered trademarks or trademarks of Adobe Systems Incorporated in the United States and/or other countries.
- In addition, system and product names used in this manual are, in general, trademarks or registered trademarks of their respective developers or manufacturers. However, the TM or © marks are not used in all cases in this manual.

Additional information on this product and answers to frequently asked questions can be found at our Customer Support Website.

<http://www.sony.net/>



Printed on 70% or more recycled paper using VOC (Volatile Organic Compound)-free vegetable oil based ink.

Printed in China



4140272110