

PRO-FORM[®]
CROSS WALK
DUAL • MOTION • CROSS • TRAINER

Model No. 831.297300

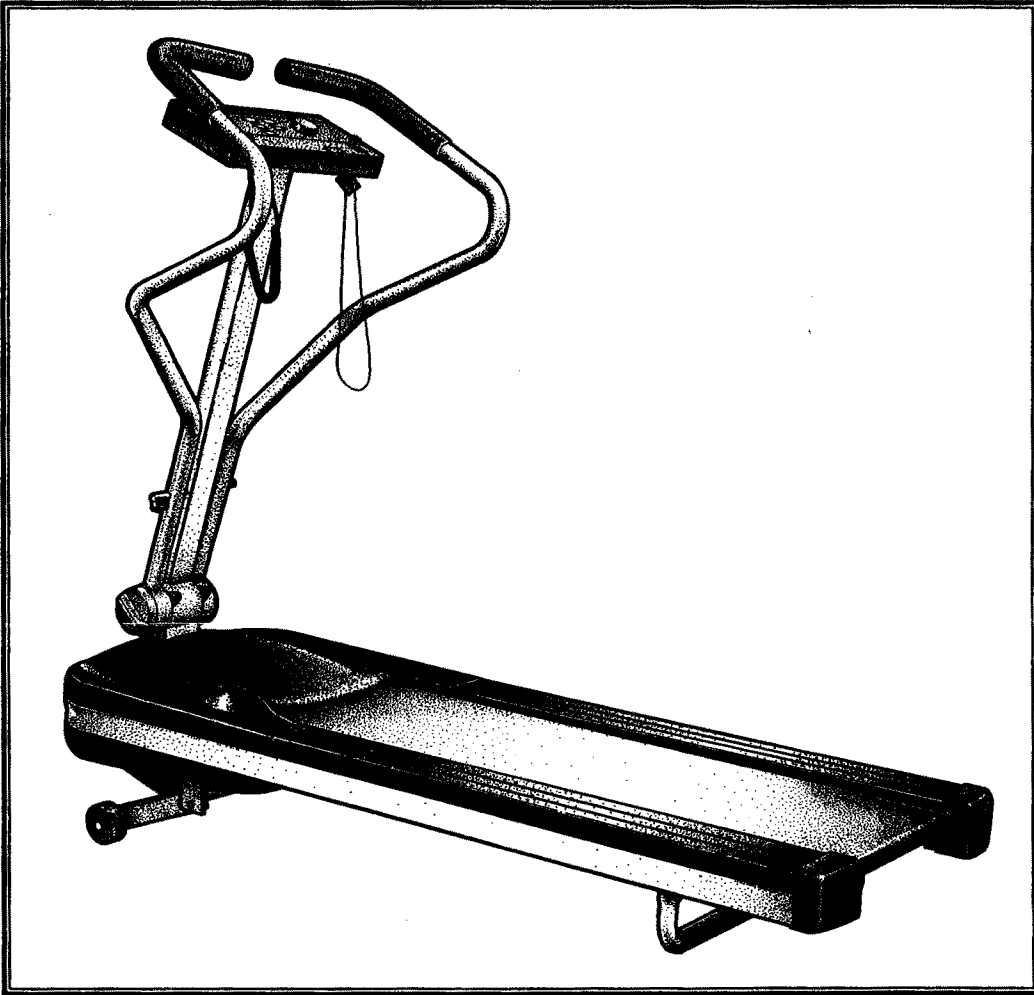

OWNER'S MANUAL

SEARS[®]

▲WARNING: For your safety, read and understand all safety precautions and instructions in this manual before using the CROSS WALK Dual Motion Cross Trainer. Save this manual for future reference.

TABLE OF CONTENTS

LIMITED WARRANTY	3
IMPORTANT SAFETY PRECAUTIONS	4
BEFORE YOU BEGIN	5
OPERATION AND ADJUSTMENT	6
TROUBLE-SHOOTING AND MAINTENANCE	9
CONDITIONING GUIDELINES	11
PART LIST	13
EXPLODED DRAWING	14
ORDERING REPLACEMENT PARTS	Back Cover

FULL 90 DAY WARRANTY ON PARTS

For 90 days from the date of purchase, when proper assembly and maintenance procedures detailed in the Owner's Manual are followed, SEARS will, free of charge, repair or replace and install a replacement part for any defective part, when the CROSS WALK is used in a normal manner.

This warranty does not apply when the CROSS WALK is used for commercial or rental purposes.

SERVICE IS AVAILABLE SIMPLY BY CONTACTING YOUR NEAREST SEARS SERVICE CENTER/DEPARTMENT IN THE UNITED STATES.

This warranty gives you specific legal rights, and you may also have other rights which vary from state to state.

**SEARS, ROEBUCK AND CO., DEPT. 817WA,
3333 BEVERLY ROAD, HOFFMAN ESTATES, IL 60179**

IMPORTANT SAFETY PRECAUTIONS

▲ WARNING: To reduce the risk of burns, fire, electric shock or injury to persons, read the following important safety precautions and information before operating the CROSS WALK.

1. Place the CROSS WALK on a level surface, with at least 8 feet of clearance behind. Do not place the CROSS WALK near water, outdoors or on any surface that blocks air openings. Do not operate where aerosol products are used or where oxygen is being administered.
2. Plug the power cord directly into a grounded circuit carrying 12 or more amps. No other appliances should be on the same circuit. (See OPERATION AND ADJUSTMENT for proper grounding instructions.) Keep the power cord away from heated surfaces. If an extension cord is needed, use only a 14-gauge general-purpose cord of approximately five feet in length with a three-wire conductor.
3. Never move the walking belt while the power is turned off. Do not operate the treadmill if the power cord or plug is damaged, or if the CROSS WALK is not working properly. (See BEFORE YOU BEGIN if the CROSS WALK is not working properly.)
4. The roller guards must be 1/8 inch from the rear roller. Turn the power off and adjust the roller guards, if necessary.
5. Wear appropriate clothing when exercising. Never wear loose clothing that could become caught in the CROSS WALK. *Always wear running shoes; never use the CROSS WALK with bare feet, wearing only stockings or in sandals.* Athletic support clothes are recommended for both men and women.
6. The pulse earclip is not a medical device. Various factors, including the user's movement while exercising, may affect the accuracy of heart rate readings. The earclip is intended only as an exercise aid in determining heart rate trends in general.
7. Never start the CROSS WALK while you are standing on the walking belt. Always hold the upper body arms when exercising on the CROSS WALK.
8. To reduce the possibility of overheating, never operate the CROSS WALK continuously for longer than 1 hour.
9. Never allow more than one person on the CROSS WALK at a time. The CROSS WALK should be used only by persons weighing 250 pounds or less.
10. Use the CROSS WALK only as described in this manual.
11. Keep small children away from the CROSS WALK at all times. Never leave the CROSS WALK unattended while the walking belt is moving. Always turn the power off when the CROSS WALK is not in use.
12. Never drop or insert any object into any opening.
13. The CROSS WALK is capable of high speeds. Adjust the speed slowly to avoid sudden jumps in speed.
14. Always unplug the power cord before performing the maintenance and adjustment procedures described in this manual. Never remove the motor hood unless instructed to do so by an authorized service representative. Servicing other than the procedures described in this manual should be performed by an authorized service representative only.

▲ WARNING: Before beginning this or any exercise program, consult your physician. This is especially important for persons over the age of 35 or persons with pre-existing health problems. Read all instructions before using the CROSS WALK. SEARS assumes no responsibility for personal injury or property damage sustained by or through the use of the CROSS WALK.

SAVE THESE INSTRUCTIONS

BEFORE YOU BEGIN

Congratulations for selecting the PROFORM® CROSS WALK Dual Motion Cross Trainer. The CROSS WALK combines the best features of today's most popular home exercise equipment in one compact unit. The natural motion and versatility of treadmills have made them the most popular way to get an effective lower body and cardiovascular workout. Now with the dual motion design of the CROSS WALK, you can get a complete upper body workout as well. And the adjustability of the CROSS WALK allows every user to work at their own level. Whether you are a beginner or a seasoned athlete, you'll enjoy the performance and uncompromising quality that only the CROSS WALK offers.

For your safety and benefit, read this manual carefully before using the CROSS WALK. If you have additional questions, please call our Customer Service Department toll-free at 1-800-999-3756, Monday through Friday, 6 a.m. until 6 p.m. Mountain Time (excluding holidays). To help us assist you, please note the product model number and serial number before calling. The model number is 831.29730. The serial number can be found on a decal attached to the CROSS WALK (see the drawing below for the location of the decal).

Before reading further, please review the drawing below and familiarize yourself with the parts that are labeled.

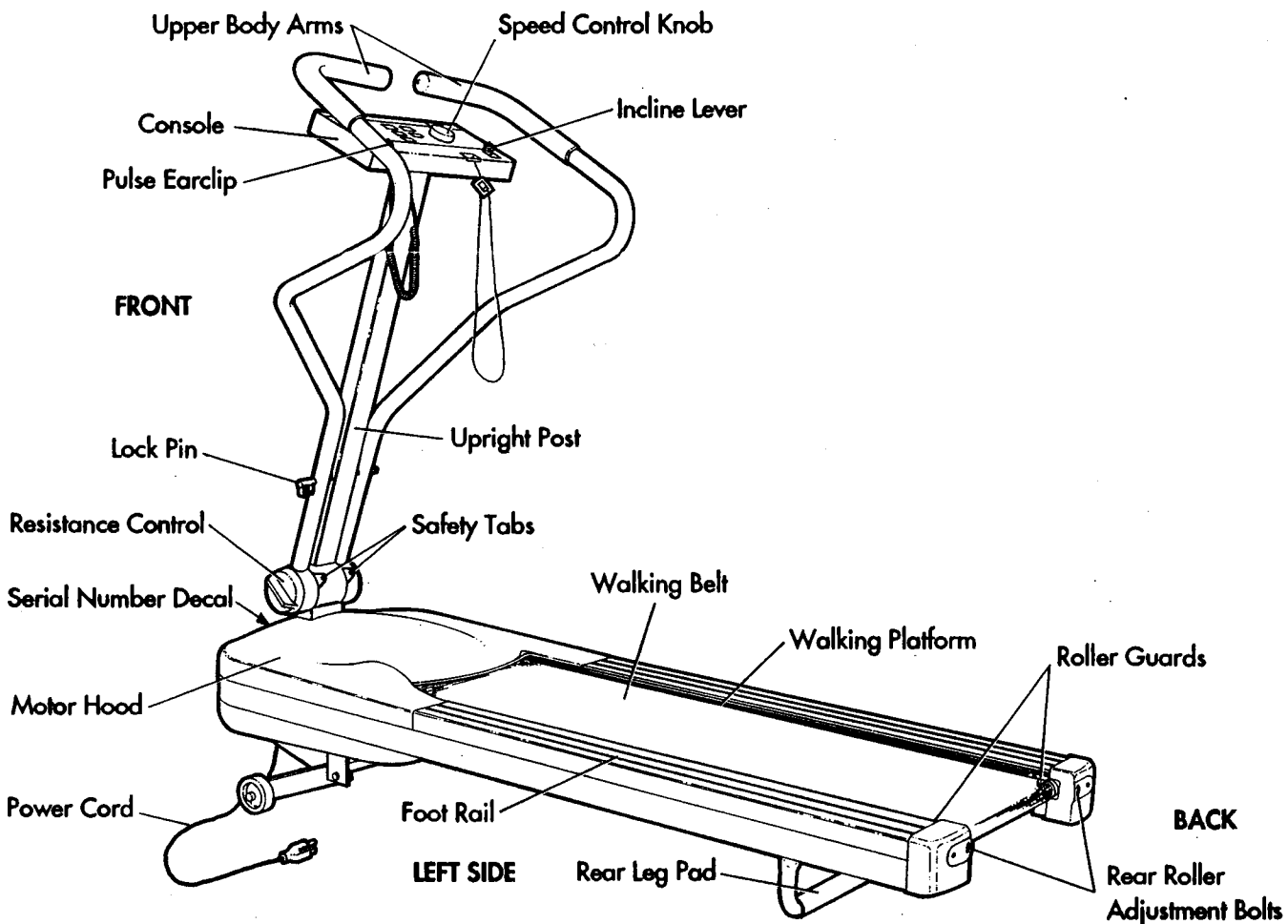

Note: The rear leg pad may mark some types of linoleum. Mild household cleaning agents will remove any marks.

OPERATION AND ADJUSTMENT

For your convenience, the CROSS WALK is delivered completely assembled in the compact stowaway position. Set the CROSS WALK in a cleared area and remove all packing materials. Make sure that all parts are included before disposing of the packing materials. To convert the CROSS WALK to the operating position, first slide the Lock Knob Washer (78) onto the Lock Knob (77). Raise the Upright (10) to the vertical position and tighten the Lock Knob into the Upright.

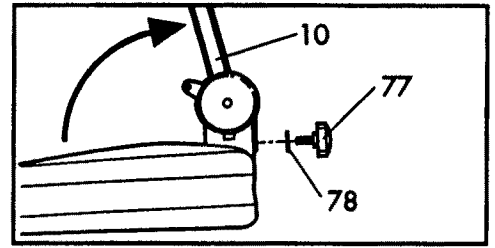

APPLYING SILICONE LUBRICANT

To reduce the friction of the walking belt and minimize wear, a non-oil, non-petroleum-base silicone lubricant must be applied to the walking platform before the CROSS WALK is used. WITH THE POWER CORD UNPLUGGED, lift each side of the walking belt and spray lubricant generously onto the indicated area. Reapply lubricant after every ten hours of use, or whenever performance decreases. Lubricant is available at hardware and automotive stores. Uni•Sport™ spray is recommended.

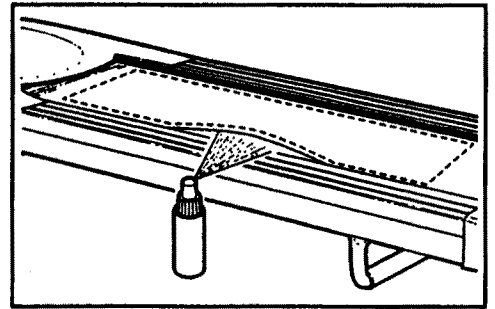

PLUGGING THE POWER CORD IN

This product must be grounded. If it should malfunction or break down, grounding provides a path of least resistance for electric current to reduce the risk of electric shock. This product is equipped with a cord having an equipment-grounding conductor and a grounding plug. Plug the power cord into an appropriate outlet that is properly installed and grounded in accordance with all local codes and ordinances.

⚠ DANGER: Improper connection of the equipment-grounding conductor can result in a risk of electric shock. Check with a qualified electrician or serviceman if you are in doubt as to whether the product is properly grounded. Do not modify the plug provided with the product—if it will not fit the outlet, have a proper outlet installed by a qualified electrician.

This product is for use on a nominal 120-volt circuit, and has a grounding plug as shown in Drawing 1. A temporary adapter like the adapter shown in Drawing 2 may be used to connect this plug to a 2-pole receptacle as shown in Drawing 2 if a properly grounded outlet is not available. The temporary adapter should be used only until a properly grounded outlet (Drawing 1) can be installed by a qualified electrician. The green-colored ear, lug, or the like extending from the adapter must be connected to a permanent ground such as a properly grounded outlet box cover. Whenever the adapter is used, it must be held in place by a metal screw. Some 2-pole receptacle outlet box covers are not grounded. Contact a qualified electrician to determine if the outlet box cover is grounded before using an adapter.

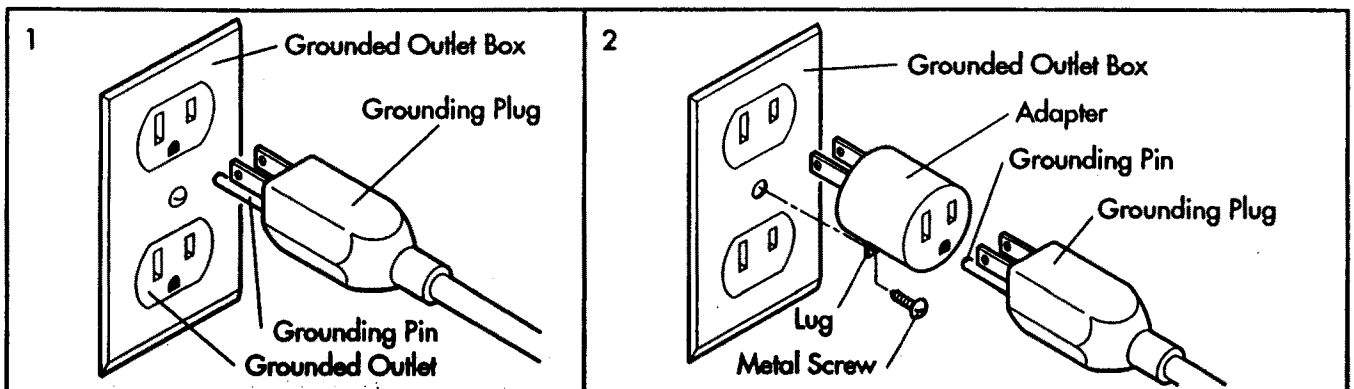
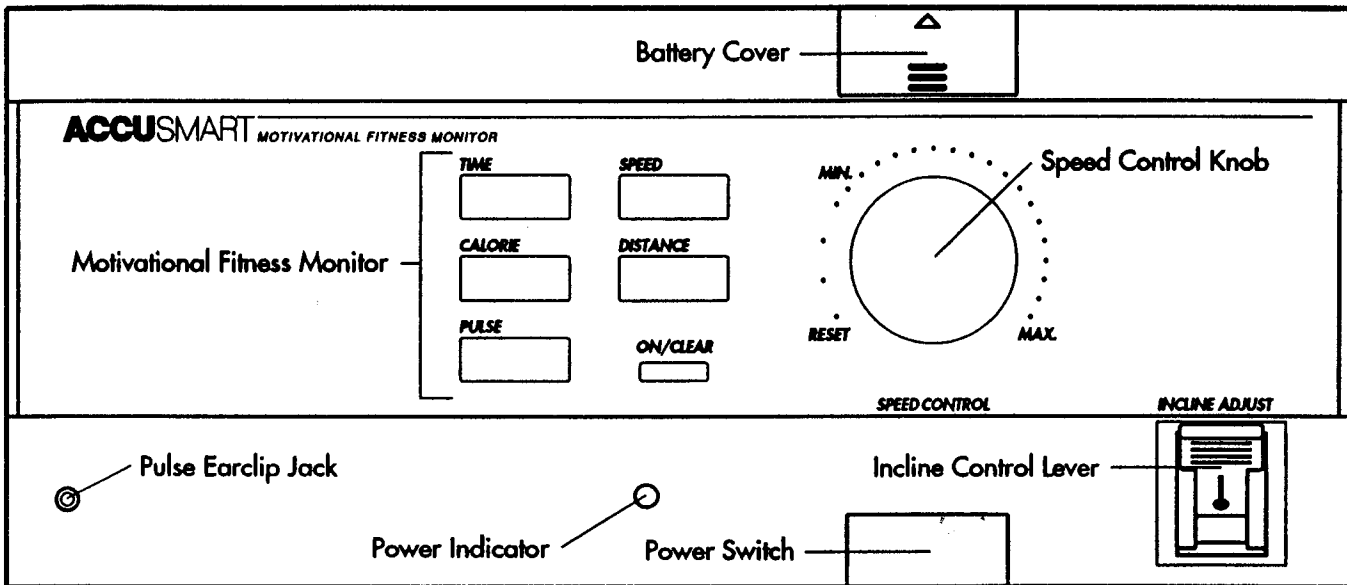

DIAGRAM OF THE CONSOLE

The CROSS WALK features the innovative ACCUSMART console, designed to help you get the most from your workouts. The ACCUSMART console offers electronic speed control, finger-touch incline control and a motivational fitness monitor with five independent displays. Please read the instructions below before operating the console.



INSTALLING BATTERIES

The motivational fitness monitor requires two "AA" batteries (not included); alkaline batteries are recommended. Slide the battery cover open and remove the battery clip from the console. Find the markings inside the battery clip showing the correct orientation of the batteries. Press the batteries into the battery clip. Replace the battery clip in the console and close the battery cover.

TURNING THE POWER ON

Step onto the foot rails of the CROSS WALK and hold the upper body arms. (See OPERATING THE UPPER BODY ARMS on the following page.) Locate the clip attached by a cord to the safety key. Slide the clip onto the waistband of your clothing. **CAUTION: Do not stand on the walking belt while turning the power on. Always wear the clip while operating the CROSS WALK; if you fall, the safety key will be pulled from the power switch, instantly turning the power off.**

Insert the safety key into the power switch. The power indicator will light. The five displays of the motivational fitness monitor will not light until the ON/CLEAR button is pressed or the walking belt begins to move. (See CONTROLLING THE SPEED OF THE WALKING BELT below.) Note: If batteries were just installed, the five displays will be lighted already.

CONTROLLING THE SPEED OF THE WALKING BELT

For your safety, the walking belt will be motionless each time the power is turned on. To start the walking belt, first turn the speed control knob to the "reset" position. Next, turn the knob slowly clockwise until the walking belt begins to move at slow speed. **CAUTION: After the knob is turned, there will be a brief pause before the walking belt begins to move. Adjust the speed slowly until you are familiar with the operation of the CROSS WALK.**

Step carefully onto the walking belt and begin exercising. Change the speed of the walking belt as desired by turning the speed control knob. Keep the speed below 2 miles per hour for walking, or increase it up to 8 miles per hour for a challenging run. To stop the walking belt, turn the knob to the "reset" position.

CHANGING THE INCLINE

To vary the intensity of your exercise, the incline of the CROSS WALK can be changed using the lever on the right side of the console. The incline can be adjusted from a minimum of 1.5% up to a maximum of 12%. To increase the incline, stand toward the back of the foot rails and pull back the lever until the desired incline is reached. To decrease the incline, stand toward the front of the foot rails, lean forward, and pull back the lever until the desired incline is reached. **CAUTION:** Do not change the incline while you are walking or running on the CROSS WALK.

OPERATING THE UPPER BODY ARMS

The unique upper body arms can be used in either the dual motion position or the stationary position. To use the arms in the dual motion position, remove the lock pin from the arms and the upright. Insert the lock pin through the safety tabs at the base of the upright. In the dual motion position, you can move the arms forward and back as you walk or run, exercising your arms, back and shoulders for a total body workout. To tailor the intensity of your upper-body exercise, the resistance of the arms can be changed. To increase the resistance, turn the resistance control clockwise; to decrease the resistance, turn the control counter-clockwise. **CAUTION:** Always insert the lock pin through the safety tabs when using the upper body arms in the dual-motion position. If you fall while exercising, the pin will limit the downward movement of the arms.

To use the upper body arms in the stationary position, insert the lock pin through the arms and the upright. In the stationary position, the arms provide a stable handle as you focus on a lower-body workout.

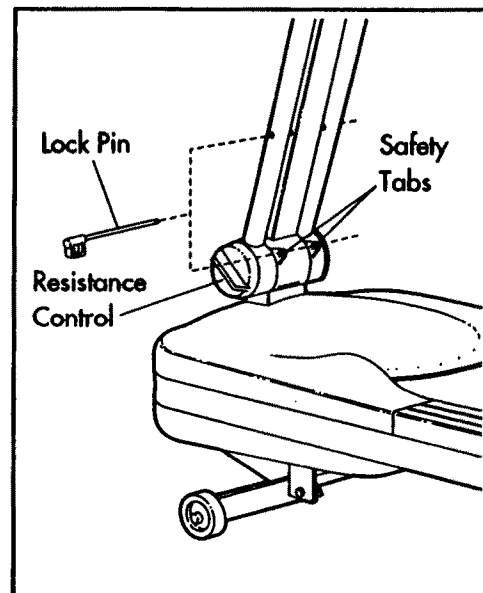

OPERATING THE MOTIVATIONAL FITNESS MONITOR

The five displays of the motivational fitness monitor are designed to provide you with instant exercise feedback. To reset the displays, press the ON/CLEAR button. The five displays are described below:

TIME—This display shows the elapsed time. Note: When the walking belt is stopped, the TIME display will go into a pause mode after a few seconds.

CALORIE—This display shows the total number of nutritional Calories that you have burned.

PULSE—This display shows your heart rate. Plug the pulse earclip into the jack on the console, and attach the earclip to your left ear lobe. (When exercising with the upper body arms in the dual motion position, attach the earclip to your right ear lobe.) Slide the clothes clip onto your collar to minimize movement of the earclip wire. After a few seconds, your heart rate will be displayed. If your heart rate is not displayed after a few seconds, rub your ear lobe and reposition the earclip. It may be helpful to stand still while measuring your heart rate.

SPEED—This display shows the current speed of the walking belt.

DISTANCE—This display shows the total distance that you have walked or run.

TURNING THE POWER OFF

To turn the power off, remove the safety key from the power switch. Keep the safety key in a secure location. The five displays of the motivational fitness monitor will turn off automatically a few minutes after the walking belt is stopped.

TROUBLE-SHOOTING AND MAINTENANCE

Most problems can be solved by following the simple steps below. If further assistance is needed, please call our Customer Service Department toll-free at 1-800-999-3756, Monday through Friday, 6 a.m. until 6 p.m. Mountain Time (excluding holidays).

1. SYMPTOM: THE POWER DOES NOT TURN ON

- a. Make sure that the power cord is plugged in properly. (See OPERATION AND ADJUSTMENT.) If an extension cord is needed, use only a 14-gauge general-purpose cord of approximately five feet in length.
- b. Make sure that the safety key is inserted fully into the console. Turn the speed control knob to the "reset" position. (See OPERATION AND ADJUSTMENT.)
- c. Check the circuit breaker located on the front of the frame. The circuit breaker is designed to protect the electrical system. If the circuit breaker has tripped, the switch will protrude as shown. To reset the circuit breaker, allow the CROSS WALK to cool for five minutes, and then push the switch back in.

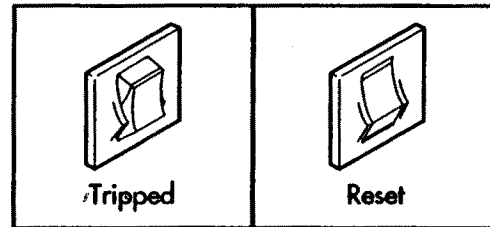

2. SYMPTOM: THE POWER TURNS OFF DURING USE

- a. Make sure that the power cord is plugged in.
- b. Check the circuit breaker located on the front of the frame. If the circuit breaker has tripped, the switch will protrude. (See the drawing above.) To reset the circuit breaker, allow the CROSS WALK to cool for five minutes, and then push the switch back in.
- c. Remove the safety key from the console. Reinsert the safety key fully into the console. Turn the speed control knob to the "reset" position.

3. SYMPTOM: THE MOTIVATIONAL FITNESS MONITOR DOES NOT FUNCTION PROPERLY

- a. Check the batteries in the console. (See OPERATION AND ADJUSTMENT.) Most problems are the result of drained batteries.

4. SYMPTOM: THE PULSE EARCLIP DOES NOT FUNCTION PROPERLY

- a. Make sure that the pulse earclip is plugged fully into the console. Attach the clothes clip to your collar.
- b. Rub your left ear lobe and reposition the earclip.
- c. Try standing still while measuring your pulse.
- d. The pulse earclip may need to be cleaned. Press the earclip open, and wipe the two clear circles inside the earclip, using a cotton swab saturated with denatured alcohol.

▲ WARNING: The pulse earclip is not a medical device. Various factors, including your movement while exercising, may affect the accuracy of heart rate readings. The earclip is intended only as an exercise aid in determining heart rate trends in general.

5. SYMPTOM: THE CROSS WALK DOES NOT INCLINE

- a. Stand at the back of the foot rails while increasing the incline. Stand at the front of the foot rails and lean forward while decreasing the incline. (See OPERATION AND ADJUSTMENT.)

6. SYMPTOM: THE WALKING BELT SLOWS WHEN WALKED ON

- a. Silicone lubricant must be applied to the walking platform before the CROSS WALK is used. Lubricant should be reapplied after every 10 hours of use, and whenever a decrease in performance is noticed. (See OPERATION AND ADJUSTMENT for application instructions.) Uni-Sport silicone spray is recommended. CAUTION: ALWAYS UNPLUG THE POWER CORD WHEN APPLYING LUBRICANT.

- b. If an extension cord is needed, use only a 14-gauge general-purpose cord of approximately five feet in length.

- c. If the walking belt is overtightened, performance may be reduced and the walking belt permanently damaged. UNPLUG THE POWER CORD. Using the allen wrench included, turn both rear roller adjustment bolts counterclockwise 1/4 of a turn. Repeat until the tension of the walking belt is correct. When the tension is correct, you should be able to lift each side of the walking belt 2-3 inches off the walking platform; the center of the walking belt should remain just at the surface of the walking platform. Be careful to keep the walking belt centered on the walking platform.

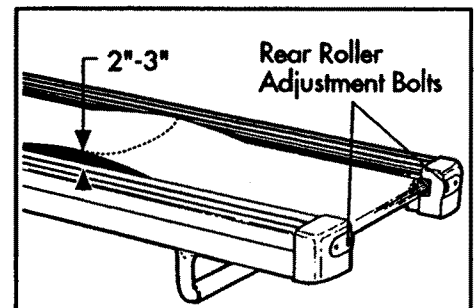

7. SYMPTOM: THE WALKING BELT IS OFF-CENTER OR SLIPS WHEN WALKED ON

- a. If the walking belt has shifted to the left, first UNPLUG THE POWER CORD. Using the allen wrench included, turn the left rear roller adjustment bolt clockwise, and the right bolt counterclockwise 1/4 of a turn each. Repeat as necessary until the walking belt is centered.

- b. If the walking belt has shifted to the right, first UNPLUG THE POWER CORD. Using the allen wrench included, turn the left rear roller adjustment bolt counterclockwise, and the right bolt clockwise 1/4 of a turn each. Repeat as necessary until the walking belt is centered.

- c. If the walking belt slips when walked on, first UNPLUG THE POWER CORD. Using the allen wrench included, turn both rear roller adjustment bolts clockwise 1/4 of a turn. Repeat as necessary until the tension of the walking belt is correct. When the tension is correct, you should be able to lift each side of the walking belt 2-3 inches off the walking platform; the center of the walking belt should remain just at the surface of the walking platform. Be careful to keep the walking belt centered on the walking platform.

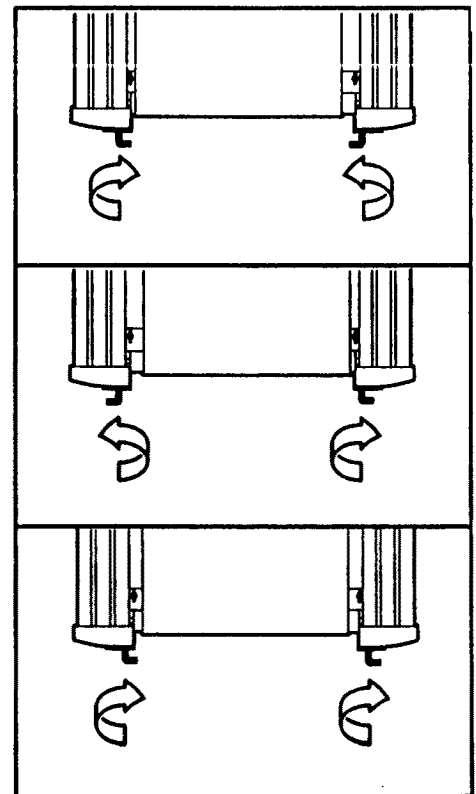

To convert the CROSS WALK to the stowaway position, first unplug the power cord. Remove the lock knob and washer from the upright and lay the upright on the walking belt. Keep the lock knob and washer in a secure location.

CONDITIONING GUIDELINES

The following guidelines will help you to plan your exercise program. Remember that proper nutrition and adequate rest are essential for successful results.

▲ WARNING: Before beginning this or any exercise program, consult your physician. This is especially important for individuals over the age of 35 or individuals with pre-existing health problems.

WHY EXERCISE?

Exercise has proven essential for good health, longevity and general well-being. Studies have shown that staying in good physical condition is better than any drug for helping to prevent or alleviate several diseases, including heart disease, diabetes and cancer. Americans are saying that the narrow fitness goals of the past have been replaced by a desire for an overall healthier lifestyle.

Regular participation in a well-rounded exercise program results in: a stronger and more efficient heart, improved respiratory function, increased stamina and endurance, better weight management and body fat control, increased ability to deal with stress, and greater self-esteem and confidence.

EXERCISE INTENSITY

To maximize the benefits of exercising, it is important to exercise with the proper intensity. The proper intensity level can be found by using your heart rate as a guide. For effective aerobic exercise, your heart rate should be maintained at a level between 70% and 85% of your maximum heart rate as you exercise. This is known as your training zone. You can find your training zone in the table below. Training zones are listed for both unconditioned and conditioned persons according to age.

AGE	UNCONDITIONED TRAINING ZONE (BEATS/MIN)	CONDITIONED TRAINING ZONE (BEATS/MIN)	AGE	UNCONDITIONED TRAINING ZONE (BEATS/MIN)	CONDITIONED TRAINING ZONE (BEATS/MIN)
20	138-167	133-162	55	127-155	122-149
25	136-166	132-160	60	126-153	121-147
30	135-164	130-158	65	125-151	119-145
35	134-162	129-156	70	123-150	118-144
40	132-161	127-155	75	122-147	117-142
45	131-159	125-153	80	120-146	115-140
50	129-156	124-150	85	118-144	114-139

During the first few months of your exercise program, keep your heart rate near the low end of your training zone as you exercise. After a few months of regular exercise, your heart rate can be increased gradually until it is near the middle of your training zone as you exercise.

You can measure your heart rate using the pulse mode of the console. Exercise for at least four minutes, and then measure your heart rate immediately. If your heart rate is too high, decrease the intensity of your exercise. If your heart rate is too low, increase the intensity of your exercise.

▲ WARNING: The pulse earclip is not a medical device. Various factors, including your movement during exercise, may affect the accuracy of heart rate readings. The earclip is intended only as an exercise aid in determining heart rate trends in general.

WORKOUT GUIDELINES

A well-rounded workout develops the heart, muscles and body composition by including the following phases:

A warm-up phase, lasting 5 to 10 minutes. Begin with slow, controlled stretches, and progress to more rhythmic stretches to increase the body temperature, heart rate and circulation in preparation for strenuous exercise. Stretching also guards against muscle, tendon and ligament sprains. (See **SUGGESTED STRETCHES** on page 13.)

A cardiovascular phase, including 20-30 minutes of exercising with your heart rate in your training zone.

A cool-down phase, consisting of 5 to 10 minutes of activity similar to that of the warm-up phase. Thorough stretching offsets muscle contractions and other problems caused when you stop exercising suddenly. Stretching for increased flexibility is often most effective during this phase. This phase should leave you relaxed and comfortably tired.

Instead of waiting for a convenient time to exercise, plan a specific time. The morning hours work well for many, and the self-discipline required to rise early and exercise often carries through the day to help increase productivity in other areas. For some, exercising before dinner initiates a period of winding-down from the day's activities. Whatever time you choose, be consistent and stick with it.

To maintain or improve your condition, complete three workouts each week, with at least one day of rest between workouts. After a few months of regular exercise, you may complete up to five workouts each week, if desired. Remember, the key to success is **CONSISTENCY**.

WORKOUT ATTIRE

Exercise clothing should be loose-fitting and comfortable, allowing unrestricted movement. Do not wear rubberized or plastic clothing that can interfere with the evaporation of sweat from your skin. Always wear athletic shoes that are flexible and provide good protection and support.

ADDITIONAL SUGGESTIONS

Creating a more active lifestyle, in addition to establishing a regular exercise program, will help you to achieve your fitness goals. It's easy to improve your lifestyle by making a few changes in your daily routine:

Keep yourself moving throughout the day. Use the stairs instead of the elevator. Park a half mile away from work, or get off the bus a couple of blocks before your stop and walking the remaining distance.

Increase midday productivity, creativity and energy by replacing a heavy lunch with a light meal. Spend the extra time in physical activity such as walking.

Substitute manually operated devices for automatic equipment such as lawn-care machinery, power tools and snow removers.

Stop smoking. Smoking nearly doubles the risk of coronary heart disease. (Framington Heart Study)

Reduce or eliminate alcohol consumption. Alcohol is a major cause of liver problems and other health disorders. (Office of Disease Prevention and Health Promotion)

Reduce your intake of fat. Less than 30% of the calories you consume each day should come from fat. Excessive fat consumption has been linked to numerous causes of death, including heart disease and cancer.

Know and keep a record of your cholesterol level, blood pressure and other health information. Keep your blood pressure below 140/90; below 125/85 is preferable.

SUGGESTED STRETCHES

The following stretches can provide a good warm-up or cool-down. Correct form for each stretch is shown in the drawings below. Move slowly as you stretch—never bounce.

TOE TOUCH STRETCH

Stand with your knees bent slightly and slowly bend forward from your hips. Allow your back and shoulders to relax as you reach down toward your toes as far as possible. Hold for 15 counts, then relax. Repeat 3 times.

Stretches: Hamstrings, back of knees and back.

HAMSTRING STRETCH

Sit with one leg extended. Bring the sole of the opposite foot toward you and rest it against the inner thigh of your extended leg. Reach toward your toes as far as possible. Hold for 15 counts, then relax. Repeat 3 times for both legs.

Stretches: Hamstrings, lower back and groin.

CALF/ACHILLES STRETCH

With one leg in front of the other, reach forward and place your hands against a wall. Keep your back leg straight and your back foot flat on the floor. Bend your front leg, lean forward and move your hips toward the wall. Hold for 15 counts, then relax. Repeat 3 times for both legs. To cause further stretching of the achilles tendons, bend your back leg as well.

Stretches: Calves, achilles tendons and ankles.

QUADRICEPS STRETCH

With one hand against a wall for balance, reach back and grasp one foot with your other hand. Bring your heel as close to your buttocks as possible. Hold for 15 counts, then relax. Repeat 3 times for both legs.

Stretches: Quadriceps and hip muscles.

INNER THIGH STRETCH

Sit with the soles of your feet together and your knees outward. Pull your feet toward your groin area as far as possible. Hold for 15 counts, then relax. Repeat 3 times.

Stretches: Quadriceps and hip muscles.

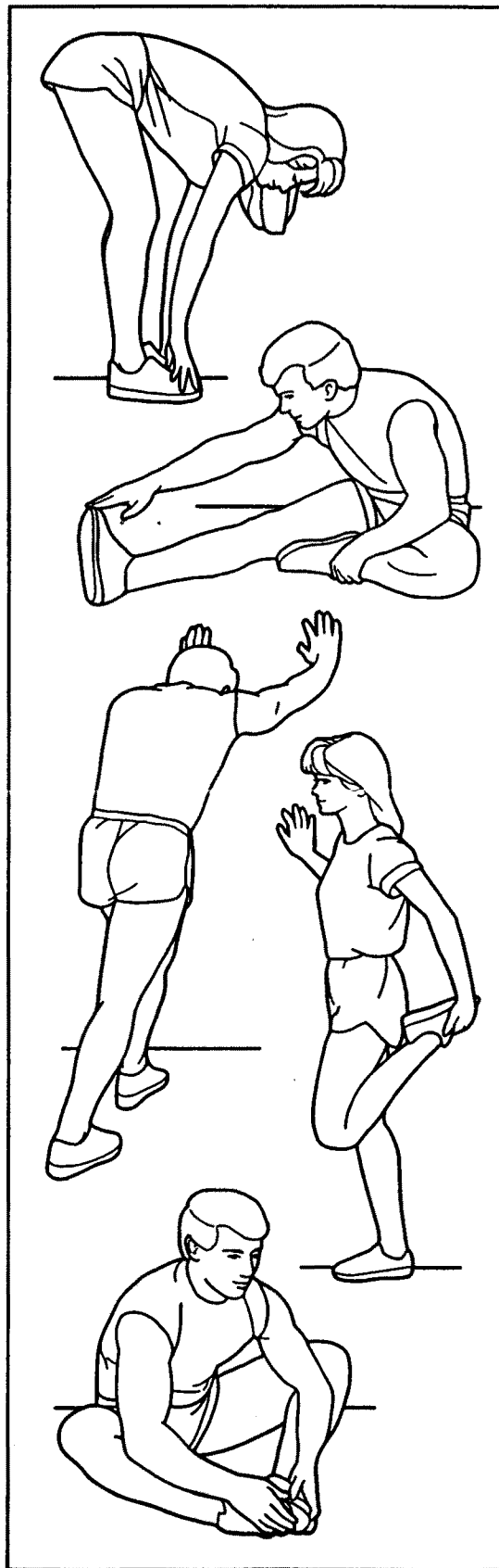

PART LIST—Model No. 831.297300

Rev. 10/92

Key No.	Reorder No.	Qty.	Description	Key No.	Reorder No.	Qty.	Description
1	110824	1	Left Upper Body Arm w/Foam	43	101263	1	Motor Pivot Bolt
2	110825	1	Right Upper Body Arm w/Foam	44	110828	1	Motor Mount Plate
3	054013	1	Clothes Clip	45	013445	4	Motor Mount Bolt
4	101508	1	Pulse Earclip	46	110827	1	Motor
5	106337	1	Safety Key/Clip	47	101630	4	Motor Mount Washer
6	108080	21	Screw	48	108276	1	Pulley/Flywheel/Fan
7	110254	1	Console	49	110048	2	Foot Rail
8	110000	1	Speed Control Knob	50	101577	2	Foot Rail Screw
9	088003	1	Incline Lever	51	013293	2	Incline Leg Bolt
10	109957	1	Upright	52	109941	1	Incline Leg
11	109855	1	Lock Pin	53	NSP	1	Frame
12	109786	1	Controller	54	110822	1	Walking Platform
13	108404	4	Hood Screw	55	100691	6	Platform Screw
14	110810	1	Motor Hood w/Decal	56	014127	3	Roller Adjustment Washer
15	109511	1	Resistance Control	57	013275	1	Front Roller Adjustment Bolt
16	110193	2	Friction Bracket	58	107873	1	Front Roller/Pulley
17	110147	2	Nylon Washer	59	110821	1	Walking Belt
18	110823	2	Upper Body Arm Housing	60	109278	8	Foot Rail Fastener
19	109806	2	Friction Plate	61	110407	1	Rear Leg Pad
20	088005	1	Incline Cable	62	110003	1	Right Roller Bracket
21	012082	7	Nut	63	013300	4	Endcap Screw
22	104514	1	Tension Spring	64	105444	2	Rear Roller Adjustment Bolt
23	014041	2	Tension Washer	65	016028	1	Wrench Clip
24	013207	1	Carriage Bolt	66	045010	1	Allen Wrench
25	109095	4	Hood Bracket	67	110245	1	Rear Roller
26	109382	1	Circuit Breaker	68	010206	2	Roller Guard
27	019084	1	Grommet	69	013162	2	Guard Screw
28	014157	1	Ground Washer	70	109265	2	Belt Guide
29	031238	1	Choke	71	110002	1	Left Roller Bracket
30	031229	1	Power Cord	72	033066	1	Magnet
31	104623	6	Belly Pan Pin	73	033208	1	Reed Switch/Sensor Wire
32	110089	1	Belly Pan	74	107428	1	Switch Screw
33	012108	3	Lock Nut	75	106939	1	Belt
34	052014	2	Front Wheel	76	016055	3	Wire Clip
35	103045	2	Wheel Bolt	77	017088	1	Lock Knob
36	088004	1	Shock Release	78	014156	1	Lock Knob Washer
37	008149	1	Shock Bracket	79	109517	1	Friction Cover
38	054016	1	E-Clip	80	109515	1	Pivot Bolt
39	059019	1	Shock Cushion	81	110194	2	Upper Body Arm Foam Grip
40	109792	1	Incline Shock	82	101049	4	Hood Bracket Screw
41	101639	1	Shock Pin	#	110084	1	Owner's Manual
42	106334	1	Cotter Pin				

Note: "#" indicates a non-illustrated part. Specifications are subject to change without notice. See the back cover of this manual for information about ordering replacement parts.

EXPLODED DRAWING—Model No. 831.297300

Rev. 10/92

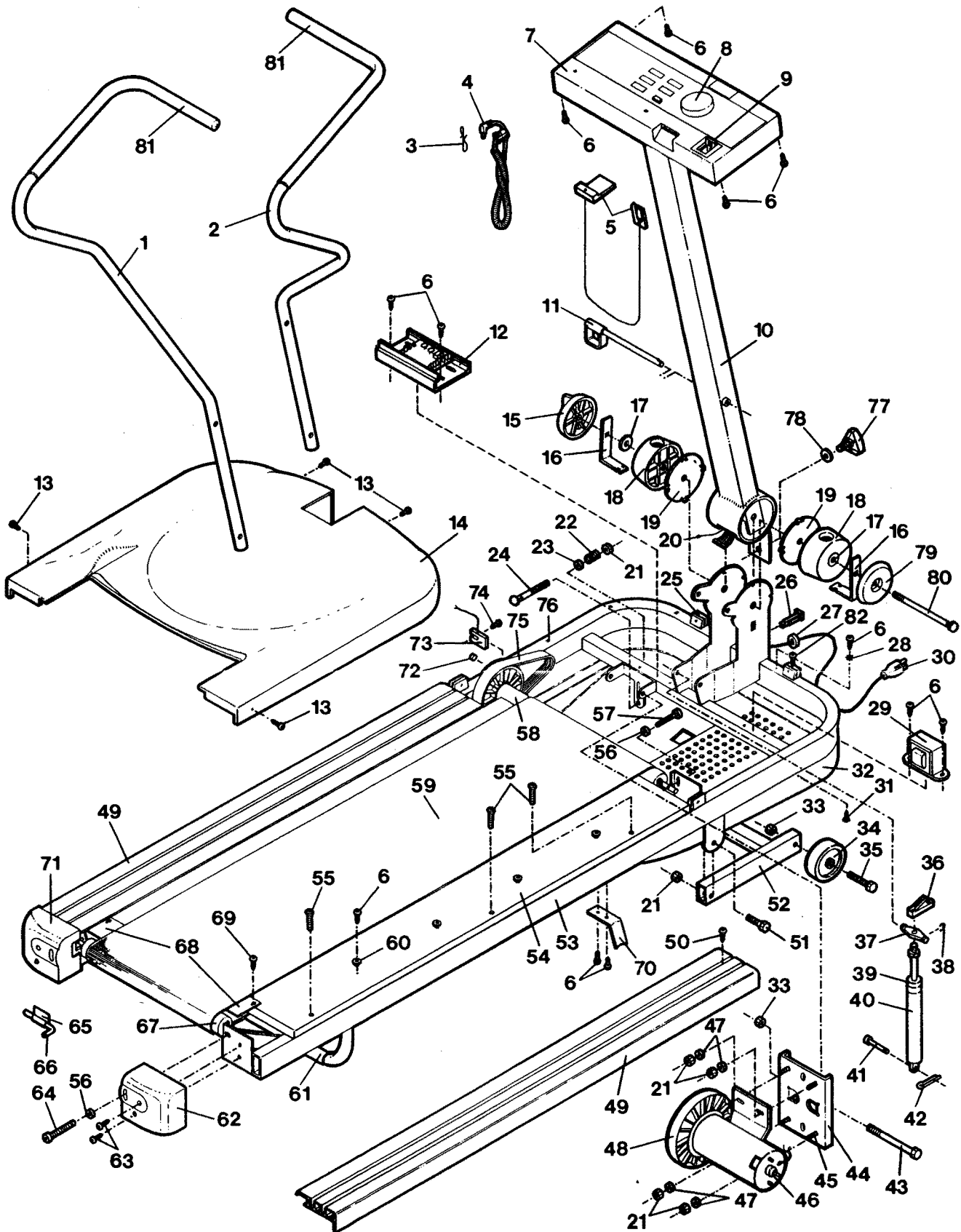

ORDERING REPLACEMENT PARTS

Each TREADMILL has its own MODEL NUMBER. Always mention the MODEL NUMBER when requesting service or repair parts for your TREADMILL.

All parts listed may be ordered through SEARS, ROEBUCK AND CO. SERVICE CENTERS and most SEARS RETAIL STORES.

If parts you need are not stocked locally, your order will be electronically transmitted to a SEARS PARTS DISTRIBUTION CENTER for expedited handling.

WHEN ORDERING REPAIR PARTS, ALWAYS GIVE THE FOLLOWING INFORMATION:

1. The MODEL NUMBER of the product (831.297300).
2. The NAME of the product. (PROFORM® CROSS WALK Dual Motion Cross Trainer)
3. The SERIAL NUMBER of the product. (See BEFORE YOU BEGIN.)
4. The REORDER NUMBER of the part(s), from page 14 of this manual.
5. The DESCRIPTION of the part(s), from page 14 of this manual.

Your SEARS merchandise has added value when you consider that SEARS has service units nationwide staffed with SEARS trained technicians specifically trained on SEARS products, having the parts, tools and equipment to ensure that we meet our pledge to you: "We service what we sell."

SOLD BY SEARS, ROEBUCK AND CO., HOFFMAN ESTATES, IL 60179

