

# Use and Care Guide



## Liquid Propane Gas Grill

Sears Model No. 122.16654900

Kmart Item No. 640-082960892-9

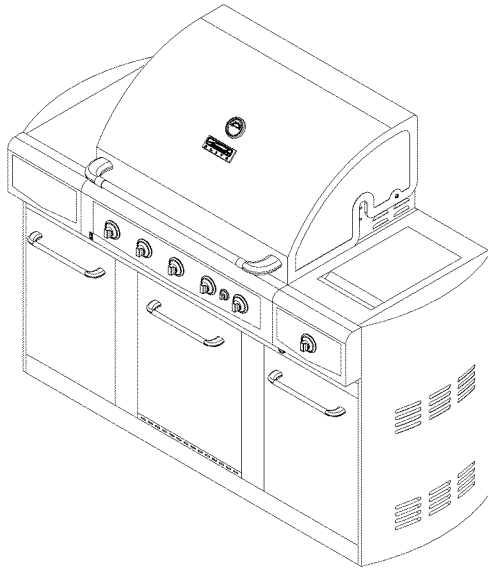

- Parts
- Assembly
- Safety Rules
- Use and Care
- Troubleshooting



### WARNING:

Read this Owner's manual carefully and be sure your gas grill is properly assembled, installed and maintained. Failure to follow these instructions could result in serious injury and/or property damage. This gas grill is intended for outdoor use only and is not intended to be installed in or on recreational vehicles or boats.

### Note to Installer

Leave this Owner's Manual with the customer after delivery and/or installation.

### Note to Consumer

Leave this Owner's Manual in a convenient place for future reference.

### Customer Service Helpline:

For parts ordering, call:  
1-800-4-MY-HOME ®

For assembly questions, call:  
1-800-913-8999  
MFG No: 810-0010

Date: 10/20/2008

## Table of Contents

Table of Contents-----	2
Warranty-----	2
Safety Precautions-----	2~4
Parts Diagram -----	5
Parts List-----	6
Assembly Instructions-----	7~8
Lighting Instructions-----	8~9
Light Operation Instruction-----	10-11
Refrigerator safety guide-----	12-13
Cleaning and Maintenance-----	14~15
Troubleshooting-----	15
Cooking Instruction-----	16
Cooking Chart-----	17

## Kenmore Grill Warranty

### Two-Year Full Warranty on Kenmore Grill

If this grill fails due to a defecting material or workmanship within two years from the date of purchase, call 1-800-4-MY-HOME to arrange for free repair (or replacement if repair proves impossible).

### Lifetime Limited Warranty on Stainless Steel Burners

For lifetime from the date of purchase, any stainless steel burner that rusts through will be replaced free of charge. After the second year from the date of purchase, you pay for labor if you wish to have it installed.

All warranty coverage excludes ignitor batteries and grill part paint loss, discoloration or rusting, which are either expendable parts that can wear out from normal use within the warranty period, or are conditions that can be the result of normal use, accident or improper maintenance,

All warranty coverage is void if this grill is ever used for commercial or rental purposes.

All warranty coverage applies only if this grill is used in the United States.

This warranty gives you specific legal rights, and you may have other right which vary from state to state.

**Sears, Roebuck and Co.,  
Hoffman Estates, IL 60179  
U.S.A.**

## Precautions

### **WARNING**

Combustion by products produced when using this product contain chemicals known to the State of California to cause cancer, birth defects, or other reproductive harm.

### **WARNING**

Failure to comply with these instructions could result in a fire or explosion that could cause serious bodily injury, death, or property damage.

### **WARNING**

**Your grill will get very hot.** Never lean over the cooking area while using your grill. Do not touch cooking surfaces, grill housing, lid or any other grill parts while the grill is in operation, or until the gas grill has cooled down after use.

**Failure to comply with these instructions may result in serious bodily injury.**

### **WARNING**

- 1. Do not store or use gasoline or other flammable liquids or vapors in the vicinity of this or any other appliance.**
- 2. An LP cylinder not connected for use shall not be stored in the vicinity of this or any other appliance.**

### **DANGER**

**If you smell gas:**

- 1. Shut off gas to the appliance.**
- 2. Extinguish any open flame.**
- 3. Open lid.**
- 4. If the odor continues, keep away from the appliance and immediately call your gas supplier or your fire department.**

### Grill Installation Codes

The installation must conform with local codes or, in the absence of local codes, with either the national fuel gas code, ANSI Z 223.1/NFPA S4, Natural gas and propane installation code, CSA B149.1, or propane storage and handling code, B149.2, or the standard for Recreational vehicles, ANSI A 119.2, and CSA Z240 RV series recreational vehicle code, as applicable.

LP gas grill models are designed for use with a standard 20 lb. Liquid Propane Gas tank, not included with grill. Never connect your gas grill to an LP gas tank that exceeds this capacity.

## Precautions

A tank of approximately 12 inches in diameter by 18-1/2 inches high is the maximum size LP gas tank to use. **You must use an OPD gas tank which offers an Overfill Prevention Device.**

This safety feature prevents the tank from being overfilled which can cause malfunction of the LP gas tank, regulator and/or grill.

The LP gas tank must be constructed and marked in accordance with specifications of the U.S. Dept. of Transportation (DOT). In Canada, the LP gas tank must meet the National Standard of Canada, Can CSA –B339, Cylinders, spheres and Tubes for Transportation of Dangerous Goods and Commission.

1. The LP gas tank must have a shutoff valve, terminating in an LP gas supply tank valve outlet, that is compatible with a Type 1 tank connection device. The LP gas tank must also have a safety relief device that has a direct connection with the vapor space of the tank.
2. The tank supply system must be arranged for vapor withdraw.
3. The LP gas tank used must have a collar to protect the tank valve.

### Proper Placement and Clearance of Grill

**Never** use your gas grill in a garage, porch, shed, breezeway or any other enclosed area. Your gas grill is to be used **outdoors only**, at least 24 inches from the back and side of any combustible surface. Your gas grill should not be used under overhead combustible construction. Do not obstruct the flow of ventilation air around the gas grill housing.

- Do not install this outdoor gas grill in or on recreational vehicles or boats
- Keep outdoor gas grill area clear and free from combustible materials, gasoline and other flammable vapors and liquids
- Do not obstruct the flow of combustion and ventilation air. Check for this each time prior to using grill.
- **Never** connect an unregulated LP gas tank to your gas grill. The gas regulator assembly supplied with your gas grill is adjusted to have an outlet pressure of 11" water column (W.C.) for connection to an LP gas tank.
- Only use the regulator and the hose assembly supplied with your gas grill. Replacement regulators and hose assemblies must be those specified in this manual.

- Have your LP gas tank filled by a reputable propane gas dealer and visually inspected and re-qualified at each filling.
- Do not store a spare LP gas tank under or near this appliance.
- Never fill the tank beyond 80 percent full. If this information is not followed exactly, a fire causing death or serious injury may occur.
- Always keep LP gas tanks in an upright position.
- Do not store (or) or use gasoline or other flammable vapors and liquids in the vicinity of this gas grill.
- Do not subject the LP gas tank to excessive heat.
- Never store an LP gas tank indoors. If you store your gas grill in the garage or other indoor location, **always** disconnect the LP gas tank first and store it safely outside.



- Place dust cap on cylinder valve outlet whenever the cylinder is not in use. Only install the type of dust cap on the cylinder valve outlet that is provided with the cylinder valve. Other types of caps or plugs may result in leakage of propane.
- LP gas tanks must be stored outdoors in a well-ventilated area and out of reach of children. Disconnected LP gas tanks must not be stored in a building, garage or any other enclosed area.
- When your gas grill is not in use the gas must be turned off at the LP gas tank.
- The regulator and hose assembly must be inspected before each use of the grill. If there is excessive abrasion or wear or if the hose is cut, it must be replaced prior to the grill being used again.
- Keep the gas regulator hose away from hot grill surfaces and dripping grease. Avoid unnecessary twisting of hose. Visually inspect the hose prior to each use for cuts, cracks, excessive wear or other damage. If the hose appears damaged do not use the gas grill. Call 1-800-4-MY-HOME for assistance.
- **Never** light your gas grill with the lid closed or before checking to ensure the burner tubes are fully seated over the gas valve orifices.
- **Never** allow children to operate your grill.
- **Warning:** The grilling unit, including, if applicable, built in refrigerator, built in lights, should never be left unattended while in use. After use of the grill, always turn off all burners and the main gas supply on the propane tank, remove the tank and unplug all electronic components before covering your grill for storage, to prevent personal injuries or property damage.

**⚠ WARNING**

A strong gas smell, or the hissing sound of gas indicates a serious problem with your gas grill or the LP gas tank. Failure to immediately follow the steps listed below could result in a fire or explosion that could cause serious bodily injury, death, or property damage.

- Shut off gas supply to the gas grill.
- Turn the control knobs to OFF position.
- Put out any flame with a proper fire extinguisher.
- Open Grill Lid.
- Get away from the LP gas tank.
- Do not try to fix the problem yourself.
- If odor continues or you have a fire you can not extinguish, call your fire department. Do not call near the LP gas tank because your telephone is a form of electrical device and could create a spark resulting in fire and/or explosion.

**NOTE:** The normal flow of gas through the regulator and hose assembly can create a humming noise. A low volume of noise is perfectly normal and will not interfere with operation of the grill. If humming noise is loud and excessive you may need to purge air from the gas line or reset the regulator excess gas flow device. This purging procedure should be done every time a new LP gas tank is connected to your grill. For help with this procedure refer to page 9, Item 4 of "If Grill Still Fails To Light", or call the Customer Service Helpline 8 AM to 5 PM PST at: 1-800-913-8999

**CAUTION: Beware of Flash-Back**

**CAUTION:** Spiders and small insects occasionally spin webs or make nests in the grill burner tubes during transit and warehousing. These webs can lead to gas flow obstruction which could result in a fire in and around burner tubes. This type of fire is known as "FLASH-BACK" and can cause serious damage to your grill and create an unsafe operating condition for the user.

Although an obstructed burner tube is not the only cause of "FLASH-BACK", it is the most common cause.

To reduce the chance of "FLASH-BACK", you must clean the burner tubes before assembling your grill, and at least once a month in late summer or early fall when spiders are most active. Also perform this burner tube cleaning procedure if your grill has not been used for an extended period of time.

See Cleaning Burner Tubes and Ports on page # 14

**Burner Flame Check**

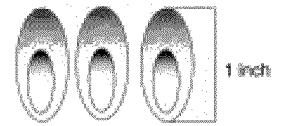
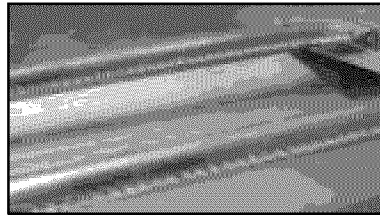

Visually check the burner flames prior to each use. The flames should look like picture, if they do not, refer to the cleaning burner tubes and ports, see page 15 of this manual.

**Repair Protection Agreements**

*Congratulations on making a smart purchase.* Your new Kenmore product is designed and manufactured for years of dependable operation. But like all products, it may require repair from time to time. That's when having a Repair Protection Agreement can save you money and aggravation.

**Here's what the Repair Protection Agreement \* includes:**

- ✓ **Expert service** by our 10,000 professional repair specialists
- ✓ **Unlimited service and no charge** for parts and labor on all covered repairs
- ✓ **Product replacement** up to \$1500 if your covered product can't be fixed
- ✓ **Fast help by phone** - we call it Rapid Resolution - phone support from a Sears representative. Think of us as a "talking owner's manual"

Once you purchase the Repair Protection Agreement, a simple phone call is all that it takes for you to schedule service. You can call anytime day or night, or schedule a service appointment online.

The Repair Protection Agreement is a risk-free purchase. If you cancel for any reason during the product warranty period, we will provide a full refund. Or, a prorated refund anytime after the product warranty period expires.

Purchase your Repair Protection Agreement today!

**Some limitations and exclusions apply. For prices and additional information in the U.S.A. call 1-800-827-6655.**

**\*Coverage in Canada varies on some items. For Full details call Sears Canada at 1-800-361-6665**

**Sears Installation Service**

*For Sears professional installation* of home appliances, garage door openers, water heaters, and other major home items, in the U.S.A. or Canada call **1-800-4-MY-HOME**

# Model 122.16654900 Parts Diagram

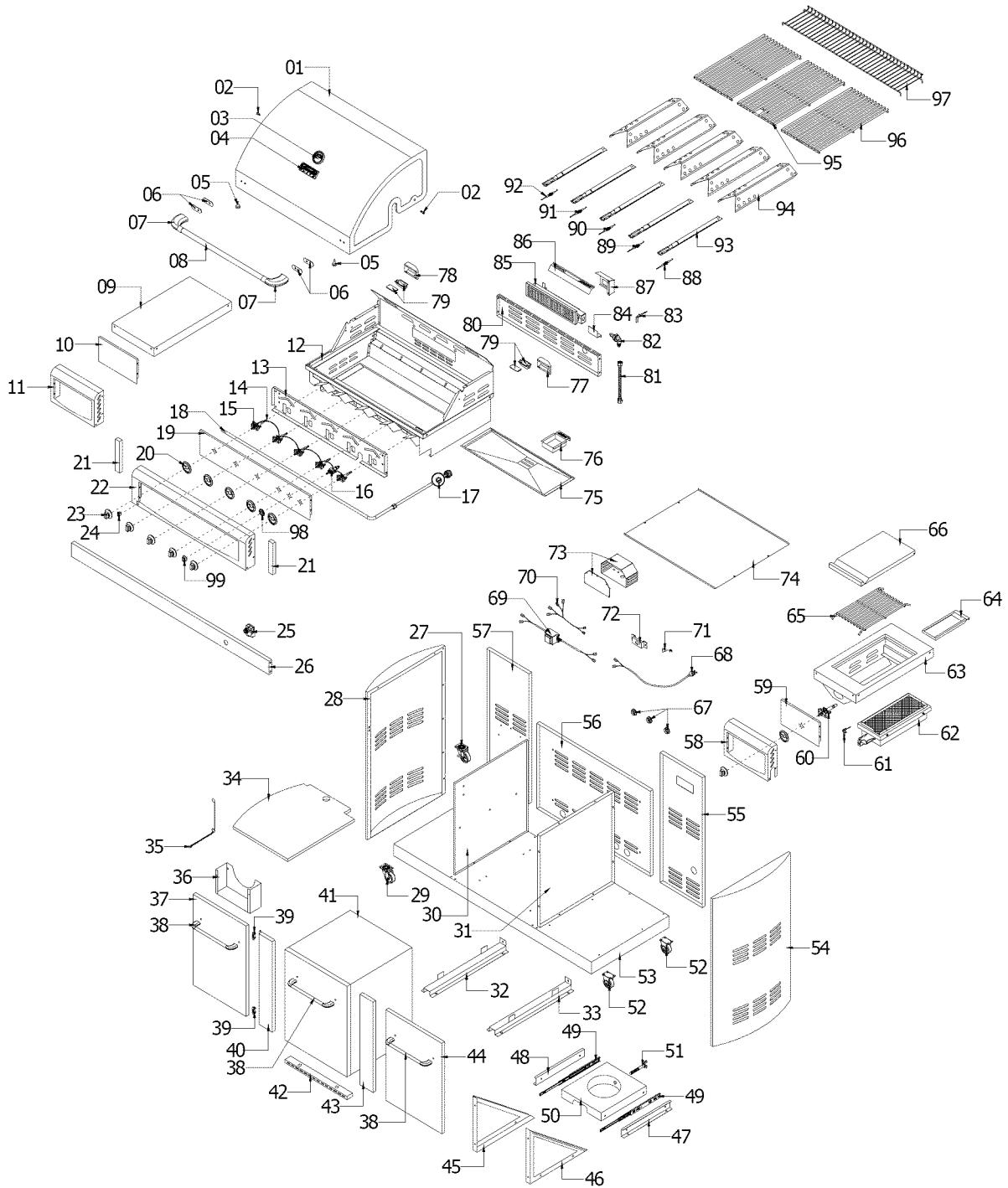

## Model# 122.16654900 / 810-0010 Parts List

KEY#	Part#	DESCRIPTION	Q'ty	KEY#	Part#	DESCRIPTION	Q'ty
1	10-001	Main Lid	1	52	10-051	Caster	2
2	10-002	Main Lid Screw	2	53	10-052	Bottom Panel	1
3	10-003	Temperature Gauge	1	54	10-053	Side Panel, Right	1
4	10-004	Logo	1	55	10-054	Back Panel, Right	1
5	10-005	Hood Buffer	2	56	10-055	Back Panel, Bottom	1
6	10-006	Main Lid Handle Heat Insulating Spacer	4	57	10-056	Back Panel, Left	1
7	10-007	Main Lid Handle Seat	2	58	10-057	Side Burner Control Panel	1
8	10-008	Main Lid Handle Tube	1	59	10-058	Side Burner Control Trim Panel	1
9	10-009	Side Shelf	1	60	10-059	Sear Gas Valve	1
10	10-010	Side Shelf Control Panel	1	61	10-060	Sear Burner Igniter Wire	1
11	10-011	Side Shelf Control Panel Frame	1	62	10-061	Sear Burner	1
12	10-012	Main burner Bowl Assembly	1	63	10-062	Sear Burner Bowl Assembly Frame	1
13	10-013	Front Baffle	1	64	10-063	Side Burner Grease Tray	1
14	10-014	Igniter Junction Wire	1	65	10-064	Side Burner Cooking Grid	1
15	10-015	Main Gas Valve	5	66	10-065	Side Burner Lid	1
16	10-016	Rotisserie Gas Valve	1	67	10-066	Rubber Grommet	3
17	10-017	Regulator, LP	1	68	10-067	Main cord	1
18	10-018	Main Manifold	1	69	10-068	Transformer	1
19	10-019	Main Control Trim Panel	1	70	10-069	Lamp Cord	1
20	10-020	Bezel	7	71	10-070	Cable Strainer	1
21	10-021	Firebox Supporting	2	72	10-071	Pow der Code Fix Bracket	1
22	10-022	Main Control Panel	1	73	10-072	Transformer Box	1
23	10-023	Control Knob	7	74	10-073	Refrigerator heat shield	1
24	10-024	Light Sw itch	1	75	10-074	Main Grease Tray	1
25	10-025	Electronic Igniter Module	1	76	10-075	Main Grease Box	1
26	10-026	Cart Frame	1	77	10-076	Lamp Cover, Right	1
27	10-027	Sw ivel Caster With Brake	1	78	10-077	Lamp Cover, Left	1
28	10-028	Side Panel, Left	1	79	10-078	Lamp	2
29	10-029	Sw ivel Caster	1	80	10-079	Back Panel, Top	1
30	10-030	Refrigerator Clapboard, Left	1	81	10-080	Rotisserie Burner Flex Line	1
31	10-031	Refrigerator Clapboard, Right	1	82	10-081	Rotisserie Orifice w/brass Elbow	1
32	10-032	Refrigerator Bracket, Left	1	83	10-082	Rotisserie Burner Igniter Wire	1
33	10-033	Refrigerator Bracket, Right	1	84	10-083	Rotisserie Igniter Wire Block Piece	1
34	10-034	Door Clapboard	1	85	10-084	Rotisserie Burner	1
35	10-035	Lighting Rod	1	86	10-085	Rotisserie Heat Shield	1
36	10-036	Condiment Tray	1	87	10-086	Rear Baffle	1
37	10-037	Door, Left	1	88	10-087	Main Buner Igniter Wire A	1
38	10-038	Door Handle	3	89	10-088	Main Buner Igniter Wire B	1
39	10-039	Door magnet	2	90	10-089	Main Buner Igniter Wire C	1
40	10-040	Front trim panel, Left	1	91	10-090	Main Buner Igniter Wire D	1
41	10-041	Refrigerator	1	92	10-091	Main Buner Igniter Wire E	1
42	10-042	Refrigerator trim panel, bottom	1	93	10-092	Main burner	5
43	10-043	Front Trim Panel, Right	1	94	10-093	Heat Diffuser	5
44	10-044	Draw er Panel, Right	1	95	10-094	Cooking Grid w ith hole	1
45	10-045	Tank Tray Guard, left	1	96	10-095	Cooking Grid	2
46	10-046	Tank Tray Guard, Right	1	97	10-096	Warming Rack	1
47	10-047	Tank Tray Slide Bracket, Right	1	98	10-097	Rear control knob	1
48	10-048	Tank Tray Slide Bracket, Left	1	99	10-098	Rear Bezel	1
49	10-049	Tank Tray Slide	2				
50	10-050	Tank Tray	1				
51	10-051	Tank Bolt	1				

For assembly questions, call:  
1-800-913-8999

For parts ordering, please call:  
1-800-4-MY-HOME<sup>®</sup>

To make sure you obtain the correct replacement parts for your Kenmore gas grill, please refer to the part numbers on this page.

Important: Use only parts listed above. When ordering parts, providing the following information:

1. Model #
2. Part Number (see PART# in chart)
3. Part Description
4. Quantity of parts needed

You can purchase the Kenmore rotisserie kit, item # 15803, or NG conversion kit, item # 710-0650, at your local Sear's store.

**Important:** Keep this Owner's Manual for convenient reference and for part replacement.

## Assembly Instructions

**CAUTION:** While it is possible for one person to assemble this grill, obtain assistance from another person when handling some of the larger, heavier pieces

1. Open lid of shipping carton and remove top sheet of cardboard. Lay cardboard sheet on floor and use as a work surface to protect floor and grill parts from scratches.
2. Remove packing materials from shipping carton.
3. You may slice the carton front corners with a utility knife to lay open the carton front panel. This will allow you to raise the grill head lid and remove the components packed inside the head
4. Use the parts list to check that all parts have been included.
5. Inspect the grill for damage as you assemble it. Do not assemble or operate the grill if it appears damaged. If there are damaged or missing parts when you unpack the shipping box, or you have questions during the assembly process, call:

**For Assembly Questions, call 1-800-913-8999  
8AM – 5 PM PST, Monday through Friday.**

**This grill is pre-assembled. All you need to do is remove the packaging material, and perform a few simple steps to set it up.**

### Installing Battery

1. Unscrew the ignition battery cap (Found at cart frame ).
2. Insert battery into ignition box with positive terminal facing outward.
3. Replace the ignition battery cap after the battery has been installed. (Fig.1)

### Connecting LP Gas Tank to LP Grill

1. Remove the screw on tank bolt & take off the washer. Insert the tank bolt from rear of the grill and reinstall the washer & screw set. From Rear of the cart, place foot ring of 20 lb tank into the hole in bottom panel. Make sure the tank valve is in OFF position. Use the tank bolt to secure the tank in a fixed position (Fig.2).
2. Check the tank valve to ensure it has proper external mating threads to fit the hose and regulator assembly provided.
3. Make sure all burner valves are in OFF position.
4. Inspect the valve connection port and regulator assembly. Look for damage or debris. Remove any debris. Inspect hose for damage. Never use damaged or plugged equipment.

5. When connecting regulator and hose assembly to tank valve hand tighten quick coupling nut clockwise to a full stop (Fig.3) Do not use a wrench to tighten because it could damage the quick coupling nut and result in a hazardous condition.

6. Open tank valve fully (counterclockwise). Use a soapy water solution to check all connections for leaks before attempting to light your grill. If a leak is found, turn tank valve off and do not use your grill until the leak is repaired.

**CAUTION: When the appliance is not in use, gas must be turned off at the supply tank.**

Figure 1

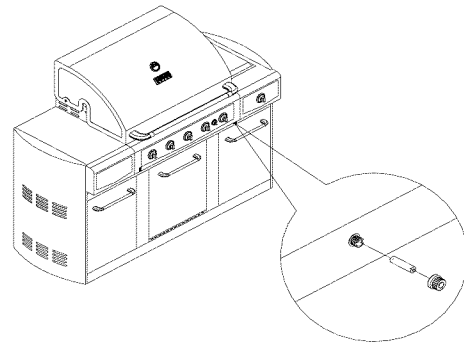

Figure 2

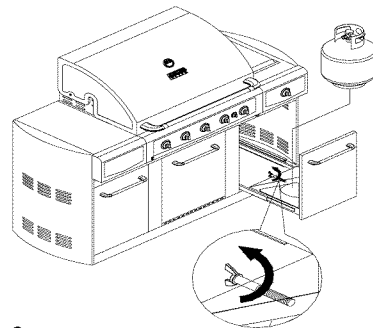
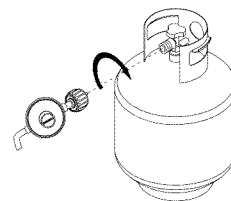

Figure 3

Regulator Connection



### Congratulations

Your Kenmore gas grill is now ready for use. Read all safety, lighting and operating instructions before use.

## Checking for LP gas leaks.

Never test for leaks with a flame. Prior to first use, at the beginning of each season, or every time your LP gas tank is changed, you must check for gas leaks.

1. Make a 50/50 mild soap solution.
2. Turn the control knobs to full OFF position; then turn gas ON at supply tank.
3. Apply the soap solution with a clean brush to all gas connections. See below. If growing bubbles appear in the solution the connections are not properly sealed. Check each fitting and tighten or repair as necessary.

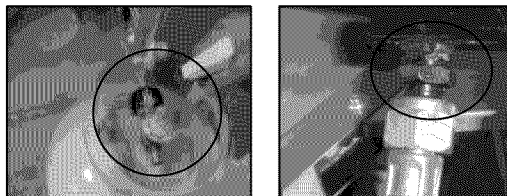

Gas Connection Leak Check

4. If you have a gas connection leak you cannot repair, turn gas OFF at supply tank, disconnect fuel line from your grill and call 1-800-4-MY-HOME or your gas supplier for repair assistance.
5. Also apply soapy solution to the tank seams. See below. If growing bubbles appear, shut tank OFF and do not use or move it! Contact an LP gas supplier or your fire department for assistance.

Gas Tank Leak Check

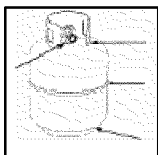

## Grill Lighting Instruction

### Grill Lighting Instructions for Main Burners

1. Do not smoke while lighting grill or checking gas supply connections.
2. Be sure that LP gas tank is sufficiently full.
3. Be sure all gas connections are securely tightened.
4. Open the grill main lid and side burner lid.
5. Push and turn any main burner knob to **HI** position, holding for 3 to 5 seconds until burner ignites.
6. To light additional burners, push and turn burner knob(s) to **HI** until burner(s) ignites, then adjust knob(s) to desired setting.



### WARNING

Failure to open grill lid during the lighting procedure could result in a fire or explosion that could cause serious bodily injury, death, or property damage.

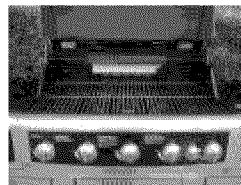

7. If the burner does not light after 5 seconds, turn knob to OFF. Turn gas OFF at LP tank and wait 5 minutes for gas to clear. Then turn gas ON at tank and repeat step 5.
8. If burner still does not light, see Match Lighting section and If Grill Still Fails to Light section on following page.

### LIGHTING INSTRUCTIONS FOR ROTISSERIE BURNER

1. Open lid during lighting.
2. To ignite, turn rotisserie knob to **ON**, hold for 3 to 5 seconds until burner ignites. If ignition does not occur in 5 seconds, turn knob to OFF, wait 5 minutes and repeat the lighting procedure.
3. Important: When using the Rotisserie Burner, do not use the Main Burners.
4. If burner still does not light, see Match Lighting section and If Grill Still Fails to Light Section on following page.

### USING THE SIDE BURNER:

Inspect the gas supply hose prior to turning the gas "ON". If there is evidence of cuts, wear or abrasion, it must be replaced prior to use. Do not use the side burner if the odor of gas is present.

**WARNING: Always keep your face and body as far away from the burner as possible when lighting.**

### LIGHTING INSTRUCTIONS FOR SIDE BURNER

1. Open side burner lid fully.
2. Push and turn side burner knob to **ON** position, holding for 3 to 5 seconds until burner ignites.
3. If the side burner does not light after 5 seconds, turn knob to OFF, turn gas OFF at LP tank and wait 5 minutes for gas to clear. Then turn gas ON at tank and repeat step 2.
4. If burner still does not light, see Match Lighting section and If Grill Still Fails to Light section on following page.

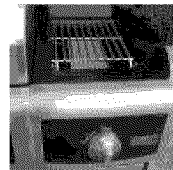

### WARNING

Never lean over the grill cooking area while lighting your gas grill. Keep your face and body a safe distance (at least 18 inches) from the cooking grid surface when lighting your grill by match.



## Manually Lighting Your Grill by Match

1. Take the manual lighting stick
2. Insert a match into the lighting stick.
3. Follow steps 1 through 5 of the Basic Lighting Procedure.
4. Light the match and extend the lighting stick to cooking grid surface.
5. Turn the desired control knob to the HI or ON setting to release gas. The burner should light immediately.

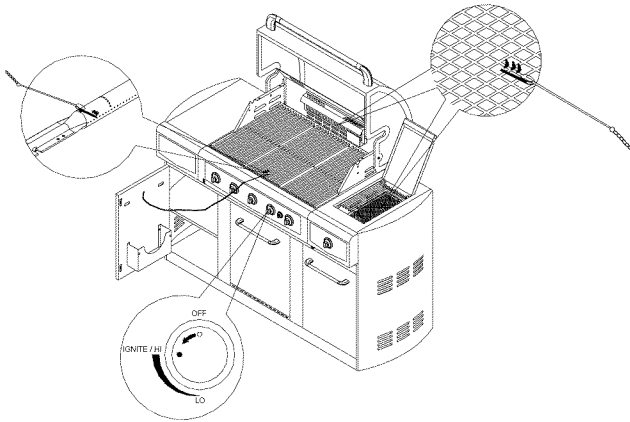

### WARNING

Should a “FLASH-BACK” fire occur in/or around the burner tubes, follow the instructions below. Failure to comply with these instructions could result in a fire or explosion that could cause serious bodily injury, death, or property damage.

- Shut off gas supply to the gas grill.
- Turn the control knobs to OFF position.
- Put out any flame with a proper fire extinguisher.
- Open grill lid.
- Once the grill has cooled down, clean the burner tubes and burners according to the cleaning instructions found on page 15.

## If Grill Still Fails To Light

1. Check gas supply and connections for leaks. Check that all wire connections are secure.
2. Repeat basic lighting procedure. If your grill still fails to operate, turn the gas off at source, turn the control knobs to OFF, then check the following:
  - Misalignment of burner tubes over orifices  
**Correction:** Reposition burner tubes over orifices.
  - Obstruction in gas line  
**Correction:** Remove fuel line from grill. Do not smoke! Open gas supply for 1 second to clear any obstruction from fuel line. Close off gas supply at source and reconnect fuel line to grill.
  - Plugged orifice  
**Correction:** Remove burners from grill, carefully lift each burner up and away from gas valve orifice. Remove the orifice from gas valve and gently clear any obstruction with a fine wire. Then reinstall all orifices, burners, and cooking components.
3. If an obstruction is suspected in gas valves, please call for repair service at 1-800-4-MY-HOME.
4. If the grill still does not light you may need to purge air from the gas line or reset the regulator excess gas flow device. **Note:** This procedure should be done every time a new LP gas tank is connected to your grill.  
**To purge air from your gas line and/or reset the regulator excess gas flow device:**
  - Turn the control knob to OFF position.
  - Turn off the gas at the tank valve.
  - Disconnect regulator from LP gas tank.
  - Let unit stand for 5 minutes.
  - Reconnect regulator to the LP gas tank.
  - Turn the tank valve on slowly until  $\frac{1}{4}$  to  $\frac{1}{2}$  open.
  - Open the grill lid.
  - Set control knobs to OFF. Push and turn any control knob to HIGH.
  - Turn control knobs to HIGH until all the burners are lit.
5. If all checks or corrections have been made and you still have questions about operating your gas grill, call the **Customer Service Helpline 8 AM – 5 PM PST, Monday through Friday at 1-800-913-8999**

## Light Operation Instructions

1. Make sure the light power switch on the control panel is in the "OFF" position.
2. Connect power plug to properly grounded outlet.
3. Turn the light power switch to "ON."

### **WARNING**

Keep any electrical supply cord away from any heated surface.

### Halogen Bulb Replacement

1. Make sure that the grill has cooled before changing the light bulb.
2. Make sure the light's power switch on the control panel is in the "OFF" position and power plug is disconnected from the outlet.
3. Use a Phillips screwdriver to loosen the screw securing the light cover.

**NOTE:** When removing final screw from light cover, make sure to use other hand to hold cover in place, ensuring it doesn't fall and shatter.

4. Loosen the screw securing the light.

5. Remove the glass cover from the light bulb housing.

**HINT:** Use a flathead screwdriver to open it easily.

Remove the glass cover from the light.

6. Use a flathead screwdriver to loosen the four screws locking the bulb in place.

Loosen but do not remove the bottom two screws under the light first.

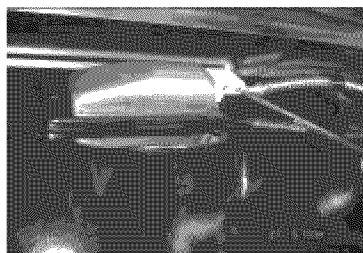
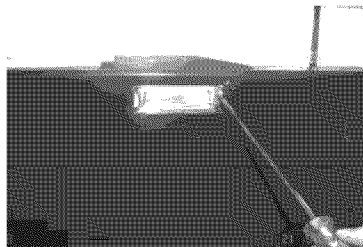
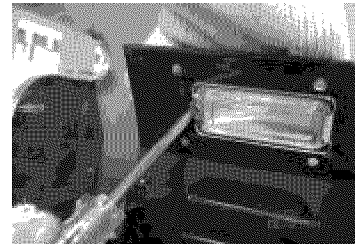
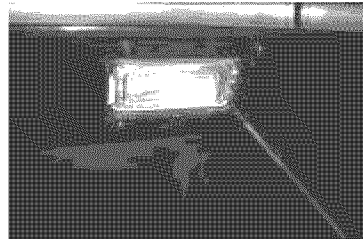

Then loosen but do not remove the upper two screws above the light.

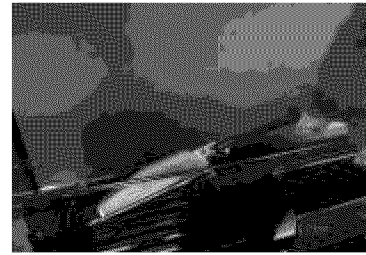

7. Pull out the light bulb and replace with a new bulb. Tighten the four screws.

**Note:** Do not touch the halogen bulb with bare hands.

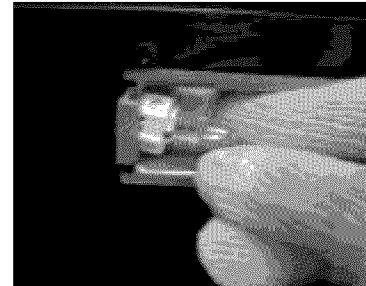

8. Replace glass cover, reinsert light bulb housing into the grill, and insert and tighten the screw.

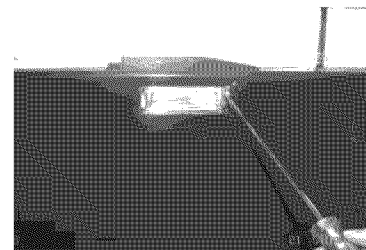

### Cleaning Method

Follow steps 1 through 4 above for glass cover removal. Use a damp towel to clean the surface of the glass cover. Make sure the glass cover is completely dry before re-installing.

#### **WARNING**

Make sure the light switch is in the "OFF" position and the power plug is disconnected from the power outlet prior to cleaning the glass cover.

#### **WARNING**

The glass cover should not be in contact with water or any other liquid when it's warm. Sudden change of temperature may cause cracks in the glass.

#### **WARNING**

To ensure continued protection against electric shock:

1. Connect to properly grounded outlets only.
2. Do not expose to rain.
3. Keep extension cord connections dry and off the ground.

Bulb Type: Halogen  
Wattage: 10 watts per bulb  
Voltage: 12 volts

If you still have questions about replace bulb, call the **Customer Service Helpline 8 AM – 5 PM PST, Monday through Friday at 1-800-913-8999.**

## Refrigerator safety guide

### IMPORTANT:

READ THE FOLLOWING PRIOR TO CONNECTING POWER AND USE

To reduce the risk of fire, electrical shock or injury when using this unit, follow basic precaution, including the following:

**Remove all packages before using this unit.**



Before the refrigerator is used, it must be **PROPERLY POSITIONED, LEVEL and installed as described in this manual.**  
**READ THIS MANUAL CAREFULLY.**



PRODUCT CERTIFIED UNDER UL471



### WARNING

1. Use two or more people to move and install this unit. Failure to do so can result in back or other injury.
2. To ensure proper ventilation for your refrigerator, the front of the unit must be completely unobstructed. Choose a well-ventilated area with temperatures above 40°F (5°C) and below 105°F (40°C). This unit must be installed in an area protected from the elements.
3. The refrigerator must be installed with all electrical connections in accordance with state and local codes. A standard electrical supply (**110V AC only , 60 Hz**), properly grounded in accordance with the National Electrical Code and local codes and ordinances is required.
4. Do not kink or pinch the power supply cord of refrigerator.
5. The fuse (or circuit breaker) size should be 15 amperes.
6. It is **important for the refrigerator to be level in order to work properly.** You may need to make several adjustments to level it.
7. Never allow children to operate, play with or crawl inside the refrigerator.
8. Do not use solvent-based cleaning agents of abrasives on the interior. These cleaners may damage or discolor the interior.
9. Do not use this appliance for any purpose other than its intended usage.

## INSTALLATION INSTRUCTIONS

### Before Using Your Unit

1. Remove the exterior and interior packing before connecting the unit to the power source, let it stand upright for approximately 2 hours. This will reduce the possibility of a malfunction in the cooling system from handling during transportation.
2. Clean the interior surface with lukewarm water using a soft cloth.

### Setting the Temperature Control

1. Your unit has only one control for regulating the temperature in the compartment. The temperature control is located on the upper side of the compartment.
2. The first time you turn the unit on, set the temperature control to "5".  
The range of the temperature control is from position "OFF" to "5". "1" is the warmest and "5" is the coolest. After 24 to 48 hours, adjust the temperature control to the setting that best suits your needs. The setting of "3" should be appropriate for normal use.
3. To turn the appliance off, turn the temperature control to "OFF".

### Electrical Connection

1. Turning the temperature control to "OFF" position stops the cooling cycle but does not shut off the power to the unit.
2. If the unit is unplugged, has lost power, or is turned off, you must wait 3 to 5 minutes before restarting the unit. If you attempt to restart before this time delay, the unit will not start.

### Food Storage

Use plastic wrap to keep food and place evenly on wire rack or drawer. Allow hot food to cool before put into this refrigerator. Allow space between different foods inside refrigerator. Keep food dry before storage.

### Refrigerator Care

1. Remove food from refrigerator if power is lost.
2. Plug the refrigerator into a properly grounded wall outlet. Do not cut or remove the third prong (ground) from the power cord under any circumstances.
3. For any questions concerning power and /or grounding, contact a certified electrician or a Sears service dealer or other qualified service dealer.
4. After plugging the refrigerator into a wall outlet, allow it to cool down for 2-3 hours before placing food in it.

Fig. A

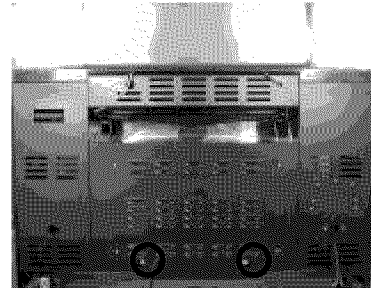

Refrigerator screws location

### Refrigerator Specifications

Voltage (V)	110
Frequency (Hz)	60
Current (A)	1.45
Input Wattage (W)	80
Volume (cu.ft.)	1.7
Dimension (mm)	440*471*494
Refrigerant	R134a
High Pressure (psig)	218
Low Pressure (psig)	88
Net Weight (kg)	17

Fig. B

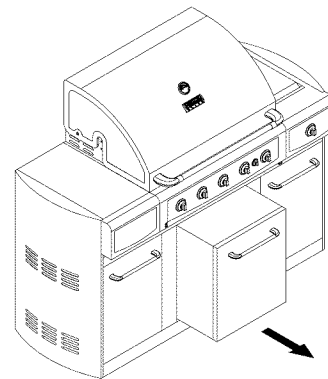

Removing refrigerator

### Refrigerator Replacement

1. Pull out the plug from the wall outlet and take out all food.
2. Unscrew the two screws from the back bracket of the refrigerator, as shown in Fig. A.
3. Pull out the refrigerator from the front of the grill, as shown in Fig. B.
4. Install the new refrigerator into the original location, put the washers and screws back in, and tighten screws securely.

 **WARNING**  
Do not replace refrigerator when plug is plugged into receptacle.

## Cleaning and Maintenance

To ensure a proper working unit the following proper care and maintenance is suggested.

### Cleaning Cooking Grids

We suggest you wash your cooking grids in a mild soap and warm water solution. You can use a wash cloth or soft brush to clean your cooking grids.

### Cleaning Heat Diffusers

Periodically you should wash the heat diffusers in a soap and warm water solution. Use a soft brush to remove stubborn burnt-on cooking residue. The heat diffusers should be dry before you reinstall them.

### Cleaning Grease Tray

The grease tray should be emptied and wiped down periodically and washed in a mild detergent and warm water solution. A small amount of sand or cat litter may be placed in bottom of grease tray to absorb the grease. Check the grease tray frequently, don't allow excess grease to accumulate and overflow out of the grease tray.

### Annual Cleaning of Grill Interior

Burning-off the grill after every use will keep it ready for your next use. However, once a year you should give the entire grill a thorough cleaning to keep it in top operating condition. Follow these steps.

1. Turn all burner valves to full OFF position.
2. Turn LP gas tank valve to full OFF position.
3. Detach LP gas hose and regulator assembly from your gas grill. Inspect for any damage and replace as necessary with manufacturer replacement part number found on parts list.
4. Remove and clean heat diffusers, cooking grids and grill burners.
5. Cover each gas valve orifice with aluminum foil.
6. Brush inside and bottom of grill with a nylon brush, and wash with a mild soap and warm water solution. Rinse thoroughly and let dry.
7. Remove the aluminum foil, then reinstall heat diffusers, and cooking grids.
8. Reconnect gas source and observe burner flame for correct operation.

### Cleaning Exterior Surface

•We suggest you wash your grill using a mild soap and warm water solution. You can use a wash cloth or sponge for this process. Do not use abrasives or a brush that might remove finish during the cleaning process.

### Cleaning Exterior Stainless Steel Surfaces

•Weathering and extreme heat can cause exterior stainless steel surfaces to turn tan in color. Machine oils used in manufacturing process of stainless steel can also cause this tanning color. Use a stainless steel cleaner to polish stainless steel surfaces of your grill. Never use abrasive cleaners or scrubbers because they will scratch and damage your grill.

### Cleaning Burner Tubes and Burner Ports

To reduce the chance of "FLASH-BACK" the procedure below should be followed at least once a month in late summer or early fall when spiders are most active or when your grill has not been used for a period of time.

1. Turn all burner valves and gas tank valve to off position.
2. Detach the LP gas regulator assembly from your gas grill.
3. Remove cooking grids, heat diffusers, and grease tray from the grill.
4. Remove the screws from the underside of each burner and lift the burners up and away from the gas valve orifice.
5. Using a bent stiff wire in the shape of a hook, air hose or a bottle brush, run it through the burner tube and inside several times to remove any debris.
6. Replace burners, see illustration below.

Step 1. Locate the burner onto the orifice.

Step 2. Secure the main burner on the back wall of fire box with 2 screws.

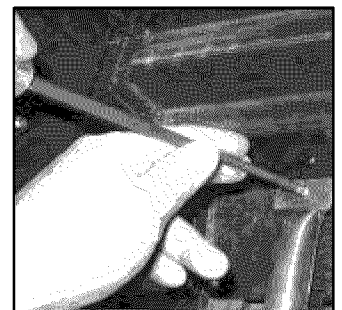
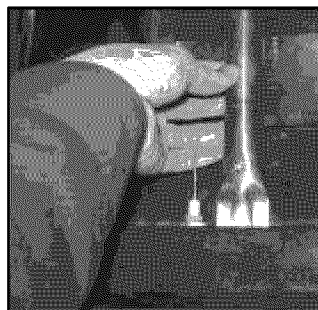

### WARNING

The location of the burner tube with respect to the orifice is vital for safe operation. Check to ensure the orifice is inside the burner tube before using the gas grill. If the burner tube does not fit over the valve orifice, lighting the burner may cause explosion and/or fire.

Regardless of which burner cleaning procedure you use, we recommend you also complete the following steps to help prolong burner life.

1. Use a fiber pad or nylon brush to clean the entire outer surface of each burner until free of food residue and dirt.
2. Clean any clogged ports with a stiff wire, such as an open paper clip.

3. Inspect each burner for damage (cracks or holes) and if such damage is found, order and install a new burner. After installation check to ensure that gas valve orifices are correctly placed inside the ends of the burner tubes.



**WARNING**

Spiders and insects can nest inside the burners of the grill and disrupt gas flow. This very dangerous condition could cause a fire behind the valve panel, thereby damaging the grill and making it unsafe for operation. Inspect the grill at least twice a year.

**Troubleshooting**

**BEFORE CALLING FOR SERVICE**

If the grill does not function properly, use the following check list before calling for service.

You should inspect the burners at least once a year or immediately after any of the following conditions occur:

<b>PROBLEMS</b>	<b>WHAT TO DO</b>
Grill won't light when the control knob is rotated.	<p>Check to see if LP tank is empty.</p> <p>Clean wires and/or electrode by rubbing with alcohol and clean swab.</p> <p>Wipe with dry cloth.</p> <p>Make sure the wire is connected to electrode assembly.</p> <p>Do other burners on the unit operate?</p> <p>Check to see if other burners operate. If so, check the gas orifice on the malfunctioning burner for an obstruction.</p>
Burner flame is yellow or orange, in combination with the odor of gas.	<p>Refer to Clean Burner Tubes and Burner Ports on page 14. If problem still exists, please call 1-800-913-8999.</p>
Low heat with knob in "HI" position.	<p>Is the fuel hose bent or kinked?</p> <p>Is the grill in a dusty area?</p> <p>Is there adequate gas supply available?</p> <p>If it is only one burner that appears low, does the orifice or burner need cleaning?</p> <p>Is the gas supply or gas pressure low?</p>

## Cooking Instructions



### WARNING

**Do not leave the grill unattended.**  
**Your grill will get very hot.** Never lean over the cooking area while using your grill. Do not touch cooking surfaces, grill housing, Grill Lid or any other grill parts while the grill is in operation, or until the grill has cooled down after use. Failure to comply with these instructions may result in serious bodily injury.

### Burn-off

Before cooking on your gas grill for the first time, you will want to “burn off” the grill to eliminate any odor or foreign matter. Just ignite the burners, lower the lid, and operate grill on the HIGH setting for 3 to 5 minutes.

### Cooking Temperatures

**High setting:** Only use this setting for fast warm-up, searing steaks or chops and for burning food residue off the grill after cooking is complete. **Never** use the HIGH setting for extended cooking.

**Medium to Low Settings:** Most recipes specify medium to low settings, including all smoking, rotisserie cooking and for cooking lean cuts such as fish.

**NOTE:** Temperature settings will vary with the temperature and the amount of wind outside your home.

### Direct Cooking

The direct cooking method can be used with the supplied cooking grids and food placed directly over the lit grill Burners. **Direct cooking requires the grill lid to be up.** The method is ideal for searing and whenever you want meat, poultry or fish to have an open-flame barbecued taste. Deep frying and smoking are also best cooked in this manner because they require direct heat.



### WARNING

Do not line the bottom of the grill housing with aluminum foil, sand or any substance that will restrict the flow of grease into the grease tray. Failure to comply with these instructions could result in a fire or explosion which could cause serious bodily injury, death, or property damage.

### Indirect Cooking

To cook **indirectly**, the food should be placed on the left or right side of your grill with the burner lit on the opposite side. **Indirect cooking must be done with the Lid down.**

### Flare-ups

The fats and juices dripping from grilled food can cause flare-ups. Since flare-ups impart a favorably distinctive taste and color to food cooked over an open flame, they should be accepted up to a point. Nevertheless, uncontrolled flaring can result in a ruined meal.



### CAUTION

To prevent damage to adjacent burner (s), the fire box heat shield must be securely inserted in place when operating the Searing burner.



## Grill Cooking Chart

**WARNING:** To ensure that it is safe to eat, food must be cooked to the minimum internal temperatures listed in the table below.

USDA* Safe Minimum Internal Temperatures	
Fish	145° F
Pork	160° F
Egg Dishes	160° F
Steaks and Roasts of Beef, Veal or Lamb	145° F
Ground Beef, Veal or Lamb	160° F
Whole Poultry (Turkey, Chicken, Duck, etc.)	165° F
Ground or Pieces Poultry (Chicken Breast, etc.)	165° F

\* United States Department of Agriculture

FOOD	Weight or thickness	Temperature	Time	Special instructions and tips
Vegetables	NA	Medium	8 to 20 minutes	Slice or chop vegetables and dot with butter or margarine. Wrap tightly in heavy duty foil. Grill turning occasionally.
Potatoes	Whole	Medium	40 to 60 minutes	Wrap individually in heavy duty foil. Cook rotating occasionally.
Meat/Steaks	1/2 to 3/4 inches	High-Medium	4 to 15 minutes	Pre heat grill for 15-20 minutes then sear steaks on each side for two minutes. Next grill 3 to 5 minutes on each side or until desired doneness.
Ground Meats	1/2 to 3/4 inches	Medium	8 to 15 minutes	Grill turning once when juices rise to the surface or until desired amount of doneness. Do not leave hamburgers unattended since a flare-up could occur quickly.
Ribs	1/2 or full rack	Medium	20 to 40 minutes	Grill turning occasionally. During last few minutes brush with barbecue sauce, turn several times.
Hot dogs	NA	Medium	5 to 10 minutes	Grill turning four times. 2-4 minutes on each of four sides.
Poultry-Cut	1/4 to 1/2 pounds	Low or Medium	20 to 40 minutes	Grill turning occasionally. During last few minutes brush with barbecue sauce if desired, turn several times.
Poultry Whole	2 to 3 pounds	Low or	1 to 1-1/2 hours	Use poultry stand and brush frequently as desired
		Medium	40 to 60 minutes	Use poultry stand and brush frequently as desired
Fish	3/4 to 1 inch	Medium	8 to 15 minutes	Grill turning once to desired doneness. Brush with melted butter, margarine or oil.

# Get it fixed, at your home or ours!

## Your Home

For expert troubleshooting and home solutions advice:

**manage my home**

[www.managemyhome.com](http://www.managemyhome.com)

For repair – **in your home** – of **all** major brand appliances, lawn and garden equipment, or heating and cooling systems, **no matter who made it, no matter who sold it!**

For the replacement parts, accessories and owner's manuals that you need to do-it-yourself.

For Sears professional installation of home appliances and items like garage door openers and water heaters.

**1-800-4-MY-HOME<sup>®</sup>** (1-800-469-4663)

Call anytime, day or night (U.S.A. and Canada)

[www.sears.com](http://www.sears.com)    [www.sears.ca](http://www.sears.ca)

## Our Home

For repair of carry-in items like vacuums, lawn equipment, and electronics, call anytime for the location of your nearest

**Sears Parts & Repair Service Center**

**1-800-488-1222** (U.S.A.)

[www.sears.com](http://www.sears.com)

**1-800-469-4663** (Canada)

[www.sears.ca](http://www.sears.ca)

To purchase a protection agreement on a product serviced by Sears:

**1-800-827-6655** (U.S.A.)

**1-800-361-6665** (Canada)

Para pedir servicio de reparación a domicilio, y para ordenar piezas:

**1-888-SU-HOGAR<sup>®</sup>**

(1-888-784-6427)

Au Canada pour service en français:

**1-800-LE-FOYER<sup>MC</sup>**

(1-800-533-6937)

[www.sears.ca](http://www.sears.ca)

**Sears**

® Registered Trademark / <sup>TM</sup> Trademark / <sup>SM</sup> Service Mark of Sears Brands, LLC

© Marca Registrada / <sup>TM</sup> Marca de Fábrica / <sup>SM</sup> Marca de Servicio de Sears Brands, LLC

<sup>MC</sup> Marque de commerce / <sup>MD</sup> Marque déposée de Sears Brands, LLC

© Sears Brands, LLC