

SAVE THIS MANUAL
FOR FUTURE
REFERENCE

SEARS

**owners
manual**

**MODEL NO.
113.244512**

Serial
Number _____
Model and serial
number may be found
at the right-hand side
of the frame.

You should record both
model and serial
number in a safe place
for future use.

CAUTION:

Read **GENERAL** and
**ADDITIONAL SAFETY
INSTRUCTIONS**
carefully



CRAFTSMAN

**10-INCH DIRECT DRIVE
BAND SAW**

- *assembly*
- *operating*
- *repair parts*

Sold by SEARS, ROEBUCK AND CO., Chicago, IL. 60684 U.S.A.

FULL ONE YEAR WARRANTY ON CRAFTSMAN BAND SAW

If within one year from the date of purchase, this Craftsman Band Saw fails due to a defect in material or workmanship, Sears will repair it, free of charge.

WARRANTY SERVICE IS AVAILABLE BY SIMPLY CONTACTING THE NEAREST SEARS SERVICE CENTER/DEPARTMENT THROUGHOUT THE UNITED STATES.

THIS WARRANTY APPLIES ONLY WHILE THIS PRODUCT IS USED IN THE UNITED STATES.

This warranty gives you specific legal rights, and you may also have other rights which vary from state to state.

SEARS, ROEBUCK AND CO., 698/731A, Sears Tower, Chicago, IL 60684

general safety instructions for power tools

1. KNOW YOUR POWER TOOL

Read and understand the owner's manual and labels affixed to the tool. Learn its application and limitations as well as the specific potential hazards peculiar to this tool.

2. GROUND ALL TOOLS

This tool is equipped with an approved 3-conductor cord and a 3-prong grounding type plug to fit the proper grounding type receptacle. The green conductor in the cord is the grounding wire. Never connect the green wire to a live terminal.

3. KEEP GUARDS IN PLACE

— in working order, and in proper adjustment and alignment.

4. REMOVE ADJUSTING KEYS AND WRENCHES

Form a habit of checking to see that keys and adjusting wrenches are removed from tool before turning it on.

5. KEEP WORK AREA CLEAN

Cluttered areas and benches invite accidents. Floor must not be slippery due to wax or sawdust.

6. AVOID DANGEROUS ENVIRONMENT

Don't use power tools in damp or wet locations or expose them to rain. Keep work area well lighted. Provide adequate surrounding work space.

7. KEEP CHILDREN AWAY

All visitors should be kept a safe distance from work area.

8. MAKE WORKSHOP CHILD-PROOF

— with padlocks, master switches, or by removing starter keys.

9. DON'T FORCE TOOL

It will do the job better and safer at the rate for which it was designed.

10. USE RIGHT TOOL

Don't force tool or attachment to do a job it was not designed for.

11. WEAR PROPER APPAREL

Do not wear loose clothing, gloves, neckties or jewelry (rings, wristwatches) to get caught in moving parts. NONSLIP footwear is recommended. Wear protective hair covering to contain long hair. Roll long sleeves above the elbow.

12. USE SAFETY GOGGLES (Head Protection)

Wear safety goggles (must comply with ANSI

Z87.1) at all times. Everyday eyeglasses only have impact resistant lenses, they are NOT safety glasses. Also, use face or dust mask if cutting operation is dusty, and ear protectors (plugs or muffs) during extended periods of operation.

13. SECURE WORK

Use clamps or a vise to hold work when practical. It's safer than using your hand, frees both hands to operate tool.

14. DON'T OVERREACH

Keep proper footing and balance at all times.

15. MAINTAIN TOOLS WITH CARE

Keep tools sharp and clean for best and safest performance. Follow instructions for lubricating and changing accessories.

16. DISCONNECT TOOLS

before servicing; when changing accessories such as blades, bits, cutters, etc.

17. AVOID ACCIDENTAL STARTING

Make sure switch is in "OFF" position before plugging in.

18. USE RECOMMENDED ACCESSORIES

Consult the owner's manual for recommended accessories. Follow the instructions that accompany the accessories. The use of improper accessories may cause hazards.

19. NEVER STAND ON TOOL

Serious injury could occur if the tool is tipped or if the cutting tool is accidentally contacted.

Do not store materials above or near the tool such that it is necessary to stand on the tool to reach them.

20. CHECK DAMAGED PARTS

Before further use of the tool, a guard or other part that is damaged should be carefully checked to ensure that it will operate properly and perform its intended function. Check for alignment of moving parts, binding of moving parts, breakage of parts, mounting, and any other conditions that may affect its operation. A guard or other part that is damaged should be properly repaired or replaced.

21. DIRECTION OF FEED

Feed work into a blade or cutter against the direction of rotation of the blade or cutter only.

22. NEVER LEAVE TOOL RUNNING UNATTENDED

Turn power off. Don't leave tool until it comes to a complete stop.

additional safety instructions for band saw

Safety is a combination of operator common sense and alertness at all times when the band saw is being used.

WARNING: FOR YOUR OWN SAFETY, DO NOT ATTEMPT TO OPERATE YOUR BAND SAW UNTIL IT IS COMPLETELY ASSEMBLED AND INSTALLED ACCORDING TO THE INSTRUCTIONS ... AND UNTIL YOU READ AND UNDERSTAND THE FOLLOWING:

	PAGE
1. General Safety Instructions for Power Tools	2
2. Getting To Know Your Band Saw.....	13
3. Basic Band Saw Operation.....	15
4. Maintenance	16
5. Stability of Machine.	
Your band saw must be bolted securely to a work bench. In addition, if there is any tendency for the band saw to tip over or move during certain operations such as cutting long heavy boards, bolt your workbench to the floor.	
6. Location	
This band saw is intended for indoor use only.	
7. Protection: Eyes, Hands, Face, Ears, Body	
a. Always wear safety goggles that comply with ANSI Z87.1. Wear a face shield if operation is dusty. Wear ear plugs or muffs during extended periods of operation. Do not wear gloves, jewelry or watches. Roll long sleeves above the elbow.	
b. Do not cut pieces of material too small to hold securely by hand.	
c. Avoid awkward hand positions where a sudden slip could cause a hand to move into the blade.	
d. Never turn your band saw "ON" before clearing the table of all Objects (tools, scraps of wood, etc.) except for the workpiece and related feed or support devices for the operation planned.	
e. Make sure the blade runs downward toward the table. Always adjust tracking wheel correctly so that the blade does not run off the wheels.	
f. Always adjust blade tension correctly.	

- g. ALWAYS adjust the upper blade guide and blade guard to just clear the workpiece to protect the operator, to keep blade breakage to a minimum, and to provide maximum support for blade.
- h. When cutting a large piece of material, provide additional support at table height.
- i. Hold the work firmly against the table.
- j. Do not feed the material too fast while cutting. Only feed the material fast enough so that the blade will cut. Keep fingers away from the blade.
- k. Use caution when cutting off material which is irregular in cross section which could pinch the blade before the cut is completed. A piece of molding for example must lay flat on the table and not be permitted to rock while being cut.
- l. Use caution when cutting off round material such as dowel rods, or tubing. They have a tendency to roll while being cut causing the blade to "bite". Always clamp round material to a miter gauge, or provide equivalent support.
- m. When backing up the workpiece, the blade may bind in the kerf (cut) ... this is usually caused by sawdust clogging up the kerf or because the blade comes out of the guides. If this happens:
 - 1. Turn off the band saw ... remove plug from power source outlet ... remove cover from band saw. Insert a screwdriver or wedge in the kerf ... rotate the wheels by hand while backing up the workpiece.
- n. Never leave the band saw work area with the power on, before the machine has come to a complete stop, or without removing and storing the switch key.
- o. Never operate band saw with cover removed.
- p. Do not perform layout, assembly, or setup work on the table while the blade is moving.
- q. Turn saw "off" and remove plug from power supply outlet before installing or removing an accessory.
- r. Use only RECOMMENDED ACCESSORIES listed on page 16.

additional safety instructions for band saw

Should any part of this band saw be missing, bend, or fail in any way, or any electrical component fail to perform properly, shut off power switch and remove plug from power supply outlet. Replace damaged, missing, and/or failed parts before resuming operation.

9. Think Safety.

Safety is a combination of operator common sense and alertness whenever the band saw is in operation.

10. This band saw is designed to cut wood and wood like products only.

WARNING: DO NOT ALLOW FAMILIARITY GAINED FROM FREQUENT USE OF YOUR BAND SAW TO BECOME COMMONPLACE. ALWAYS REMEMBER THAT A CARELESS FRACTION OF A SECOND IS SUFFICIENT TO INFLICT SEVERE INJURY.



The operation of any power tool can result in foreign objects being thrown into the eyes, which can result in severe eye damage. Always wear safety goggles complying with ANSI Z87.1 (shown on Package) before beginning power tool operation. Safety Goggles are available at Sears retail or catalog stores.

READ AND FOLLOW THE INSTRUCTIONS APPEARING ON THE INSTRUCTION PLATE ON THE FRONT OF THE BAND SAW:

An instruction plate for a Sears Craftsman 10 inch Direct Drive Band Saw. The plate is rectangular with rounded corners and a black border. At the top, it says "DANGER FOR YOUR OWN SAFETY." Below that, it says "READ AND UNDERSTAND OWNER'S MANUAL BEFORE OPERATING THIS MACHINE". There are seven numbered safety instructions listed in two columns. A UL logo is in the bottom right corner. At the bottom, it says "SEARS 10 inch DIRECT DRIVE BAND SAW" and "CRAFTSMAN" in large, bold letters.

DANGER FOR YOUR OWN SAFETY.

READ AND UNDERSTAND OWNER'S MANUAL BEFORE OPERATING THIS MACHINE

- 1 ALWAYS WEAR SAFETY GOGGLES PER ANSI Z87.1 AT ALL TIMES WHEN OPERATING THIS MACHINE
- 2 BE POSITIVE THE SAW BLADE IS INSTALLED PROPERLY—TEETH POINTING DOWNWARD TOWARD THE TABLE—BEFORE OPERATING MACHINE
- 3 BE SURE BLADE TENSION, BLADE GUIDES AND THRUST BEARINGS ARE PROPERLY ADJUSTED BEFORE OPERATING MACHINE
- 4 ALWAYS ADJUST UPPER GUIDE SO THAT IT JUST CLEARS WORKPIECE
- 5 MINIMIZE INJURY POTENTIAL OF CONTACT WITH BLADE BY KEEPING FINGERS A SAFE DISTANCE AWAY
- 6 MAINTAIN CONTROL OF THE WORKPIECE AT ALL TIMES—HOLD FIRMLY AGAINST THE TABLE
- 7 BE ATTENTIVE TO THIN CUT-OFF PIECES HITTING END OF SLOT IN INSERT OR JAMMING IN SLOT. ALLOW BLADE TO STOP BEFORE REMOVING JAMMED PIECE

UL

SEARS 10" DIRECT DRIVE BAND SAW

CRAFTSMAN

motor specifications and electrical requirements

This machine is designed to use, and is equipped with, a **1725 RPM** motor. It is wired for operation on 110-120 volts, 60 Hz., alternating current. (TOOL MUST NOT BE CONVERTED TO OPERATE ON 230 VOLT).

For replacement motor refer to parts list in this manual.

CONNECTING TO POWER SUPPLY OUTLET

This machine must be grounded while in use to protect the operator from electric shock.

Plug power cord into a 110-120V properly grounded type outlet protected by a 15-amp. fuse or circuit breaker.

If you are not sure that your outlet is properly grounded, have it checked by a qualified electrician.

WARNING: DO NOT PERMIT FINGERS TO TOUCH THE TERMINALS OF PLUGS WHEN INSTALLING OR REMOVING THE PLUG TO OR FROM THE OUTLET.

WARNING: IF NOT PROPERLY GROUNDED THIS POWER TOOL CAN CAUSE AN ELECTRICAL SHOCK PARTICULARLY WHEN USED IN DAMP LOCATIONS CLOSE TO PLUMBING. IF AN ELECTRICAL SHOCK OCCURS THERE IS THE POTENTIAL OF A SECONDARY HAZARD SUCH AS YOUR HANDS CONTACTING THE SAW BLADE.

If power cord is worn or cut, or damaged in any way, have it replaced immediately.

Your unit is for use on 110-120 volts, and has a plug that looks like below.

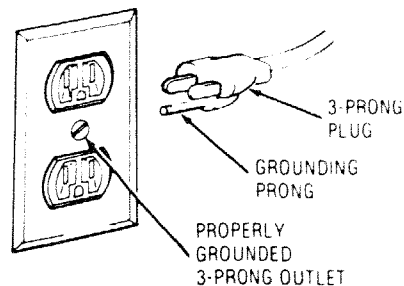

This power tool is equipped with a 3-conductor cord and grounding type plug which has a grounding prong, approved by Underwriters' Laboratories and the Canadian Standards Association. The ground conductor has a green jacket and is attached to the tool housing at one end and to the ground prong in the attachment plug at the other end.

This plug requires a mating 3-conductor grounded type outlet as shown.

If the outlet you are planning to use for this power tool is of the two prong type, DO NOT REMOVE OR ALTER THE GROUNDING PRONG IN ANY MANNER. Use an adapter as shown below and always connect the grounding lug to a known ground.

It is recommended that you have a qualified electrician replace the TWO prong outlet with a properly grounded THREE prong outlet.

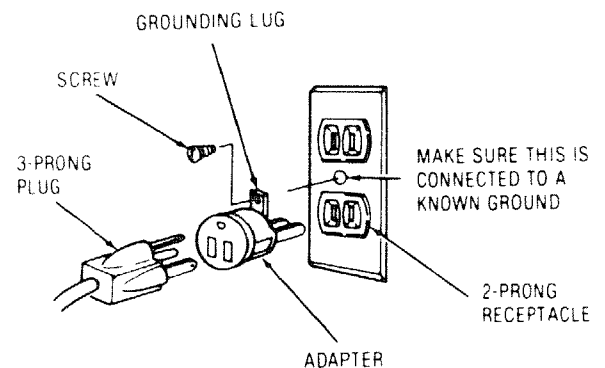

An adapter as illustrated is available for connecting plugs to 2-prong receptacles. The green grounding lug extending from the adapter must be connected to a permanent ground such as to a properly grounded outlet box.

NOTE: The adapter illustrated is for use only if you already have a properly grounded 2-prong receptacle. Adapter is not allowed in Canada by the Canadian Electrical Code.

The use of any extension cord will cause some loss of power. To keep this to a minimum and to prevent overheating and motor burn-out, use the table below to determine the minimum wire size (A.W.G.) extension cord.

Use only 3 wire extension cords which have 3-prong grounding type plugs and 3-prong receptacles which accept the tools plug.

Extension Cord Length	Wire Size A.W.G.
Up to 100 Ft.	16
100 - 200 Ft.	14
200 - 400 Ft.	10

contents

CONTENTS

POWER TOOL WARRANTY	2	Adjusting Lower Blade Guides.....	12
GENERAL SAFETY INSTRUCTIONS FOR POWER TOOLS.....	2	Drive Belt Tension	13
ADDITIONAL SAFETY INSTRUCTIONS FOR BAND SAW	3	Adjusting Table	13
MOTOR SPECIFICATIONS AND ELECTRICAL REQUIREMENTS.....	5	GETTING TO KNOW YOUR BAND SAW	
UNPACKING AND CHECKING CONTENTS.....	6	Tension Adjustment Knob.....	14
ASSEMBLY		Cover Knobs.....	14
Mounting Band Saw to Workbench.....	7	Blade Guides	14
Clamping Band Saw to Workbench.....	8	Tension Lock Knob	14
Installing the Table.....	8	Guide Bar Lock Knob	14
Installing the Blade	9	Table Lock Knobs.....	14
Tensioning the Blade.....	10	Bevel Scale	14
Tracking the Blade	11	On-Off Switch	14
Adjusting the Table Square to Blade	11	BASIC BAND SAW OPERATION	
Adjusting Upper Blade Guide		Sawing	15
Assembly.....	12	MAINTENANCE.....	16
Adjusting Upper Blade Guides.....	12	Lubrication	16
Adjusting Upper Thrust Bearing	12	RECOMMENDED ACCESSORIES	16
Adjusting Lower Blade Guide		TROUBLESHOOTING	17
Assembly.....	12	REPAIR PARTS	18

Unpacking and checking contents

TOOLS NEEDED

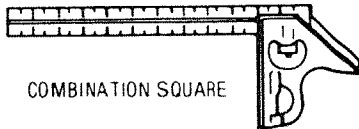

COMBINATION SQUARE

MEDIUM SCREWDRIVER



#2 PHILLIPS SCREWDRIVER

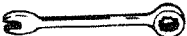
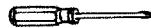

1/2 INCH WRENCH

HEX WRENCH

1/8 & 3/16

COMBINATION SQUARE MUST BE TRUE

DRAW LIGHT
LINE ON BOARD
ALONG THIS EDGE

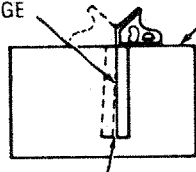

STRAIGHT EDGE OF
BOARD 3/4" THICK
THIS EDGE MUST BE
PERFECTLY STRAIGHT

SHOULD BE NO GAP OR OVERLAP HERE WHEN
SQUARE IS FLIPPED OVER IN DOTTED POSITION

WARNING: FOR YOUR OWN SAFETY, NEVER CONNECT PLUG TO POWER SOURCE OUTLET UNTIL ALL ASSEMBLY STEPS ARE COMPLETE, AND YOU HAVE READ AND UNDERSTAND THE SAFETY AND OPERATIONAL INSTRUCTIONS.

Model 113.244512 Band Saw is shipped complete in one carton.

Separate all parts from packing materials and check each item with illustration and "Table of Loose Parts". Make certain all items are accounted for, before discarding any packing material.

If any parts are missing, do not attempt to assemble the band saw, plug in the power cord, or turn the switch on until the missing parts are obtained and installed correctly.

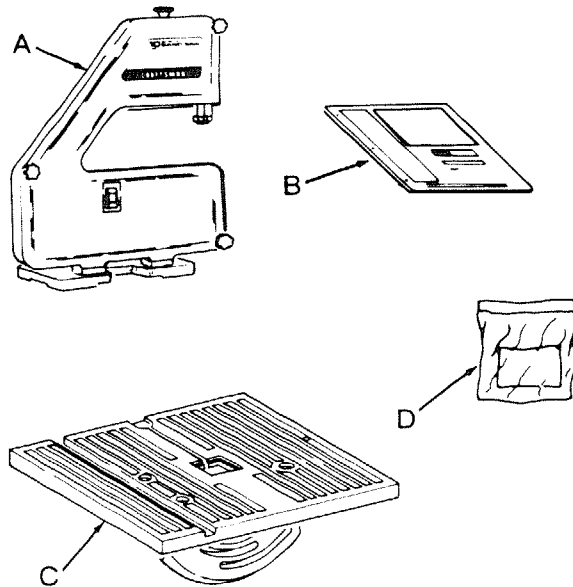

ITEM	TABLE OF LOOSE PARTS	QTY.
A	Basic saw assembly	1
B	Owners Manual	1
C	Saw Table assembly	1
D	Bag Assembly Part #69189 Containing the following parts:	
	Switch, Key	1
	Nut, Wing 1/4-20	1
	Screw, Truss Hd. 1/4-20 x 3/4	1
	Washer 17/64 x 5/8 x 1/16	1
	Washer 17/64 x 47/64 x 1/16	2
	Indicator, Bevel	1
	Screw, Pan Cross 10-24 x 1/4	1
	Insert, Table	1
	Knob	2

assembly

MOUNTING BAND SAW TO WORKBENCH

If band saw is to be used in a permanent location, it should be fastened securely to a firm supporting surface such as a workbench.

If mounting to a workbench, holes should be drilled through supporting surface of the workbench using dimensions illustrated.

1. Each leg should be bolted securely using 5/16" diameter machine screws, lockwashers, and 5/16" hex nuts (not included). Screw length should be 1 1/2" plus the thickness of the bench top.
2. Locate and mark the holes where band saw is to be mounted.
3. Drill (4) 3/8" diameter holes through workbench.
4. Place band saw on workbench aligning holes in feet with holes drilled in workbench.
5. Insert all four 5/16" screws and tighten.

NOTE: Front two mounting bolts should be inserted from the bottom with washer and nut on top.

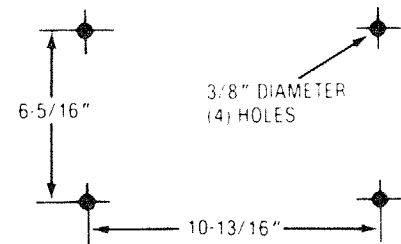

An alternate method of mounting is to fasten band saw to a mounting board. The board should be of sufficient size to avoid tipping of saw while in use. Any good grade of plywood or chipboard with a 3/4" minimum thickness is recommended. (Thinner chipboard can break.)

1. Follow instructions for mounting to workbench, substituting a board 18" x 24" minimum size and using 5/16 inch flat head screws, lockwashers, and hex nuts (not included). Screw length should be 1 1/2" plus the thickness of the mounting board.

NOTE: For proper stability, holes must be counter sunk so screw heads are flush with the bottom surface of supporting board.

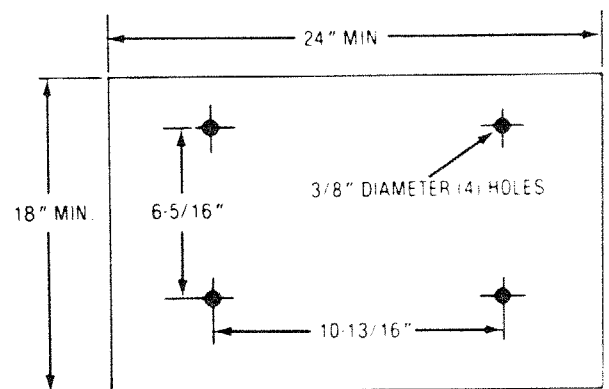

assembly

- Securely clamp board to workbench using "C" clamps.

NOTE: Supporting surface where band saw is mounted should be examined carefully after mounting to insure that no movement during use can result. If any tipping or walking is noted, secure workbench or supporting surface before operating band saw.

CLAMPING BANDSAW TO WORKBENCH

The Band Saw can be clamped directly to a workbench using two (2) or more "C" clamps on base of unit.

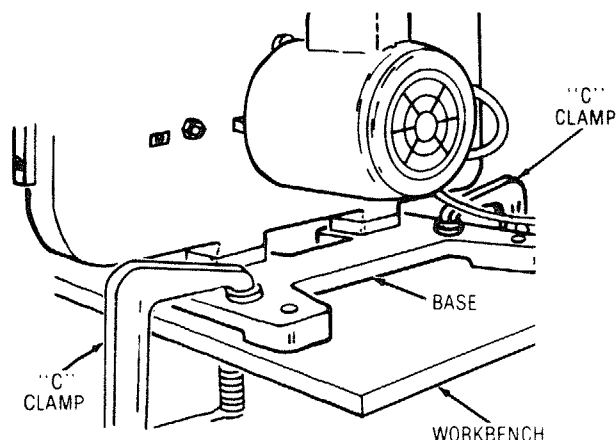

INSTALLING THE TABLE

Apply a coat of automobile wax to the table top and inside surfaces of trunnion that slide on frame.

- Loosen the guide bar lock knob and position the upper guide assembly all of the way up. Tighten lock knob.

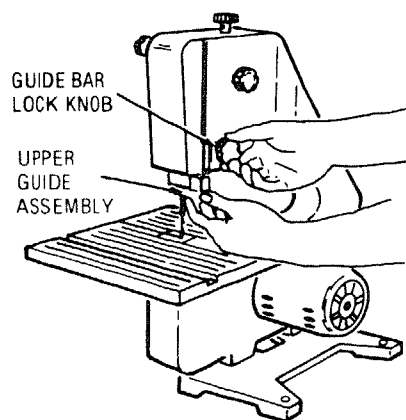

- Locate two (2) knobs and two (2) 17/64 x 47/64 x 1/16 washers in loose parts bag, and the table assembly in loose parts.
- Place table assembly onto band saw frame with the trunnion against mounting rib in frame.

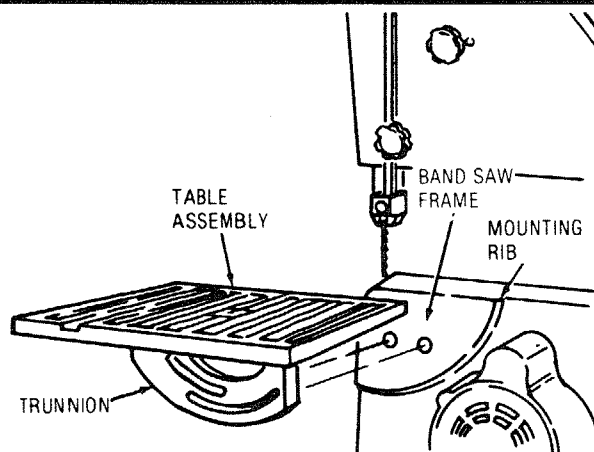

- Hold table assembly against the frame and install two (2) table lock knobs and washers as shown through the trunnion slots and tighten.

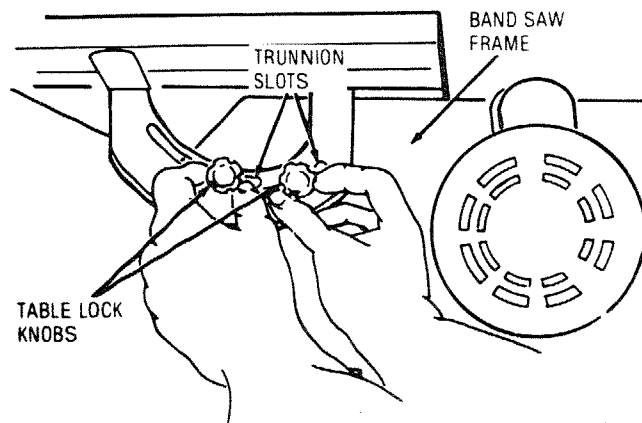

5. Locate bevel indicator and 10-24x1/4 pan cross hd. screw in loose parts bag.
6. Install bevel indicator and screw as shown using a phillips screwdriver.

NOTE: This unit comes with the Band Saw blade installed, assembly continues on p. 10. "Tensioning the Blade."

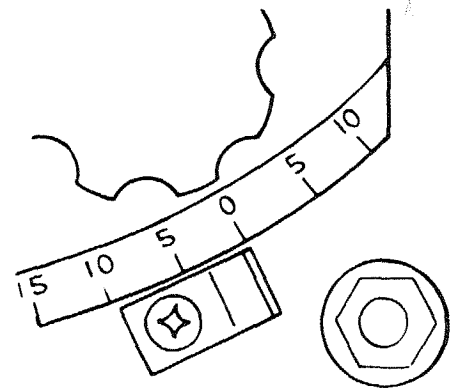

REPLACING THE BLADE

1. Loosen the guide bar lock knob and position the upper guide assembly approximately one inch above the table and tighten lock knob.
2. Loosen the two blade guard mounting screws and remove the blade guard.

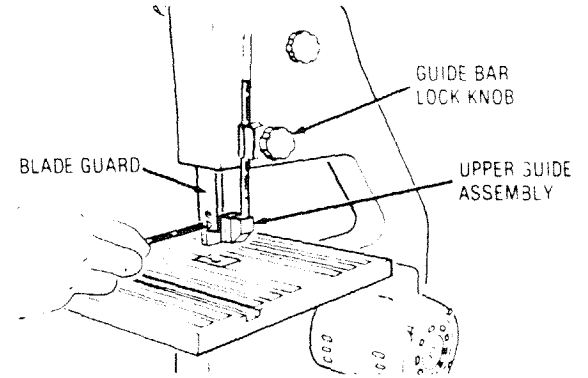

3. Loosen the guide bar lock knob and position the upper guide assembly approximately two inches above the table as shown and tighten the lock knob.
4. Remove table insert, truss head screw, washer and wing nut from the table (See Assembly, p. 13 - "Adjusting the Table"). Replace these parts after the blade is installed, tensioned and tracked.

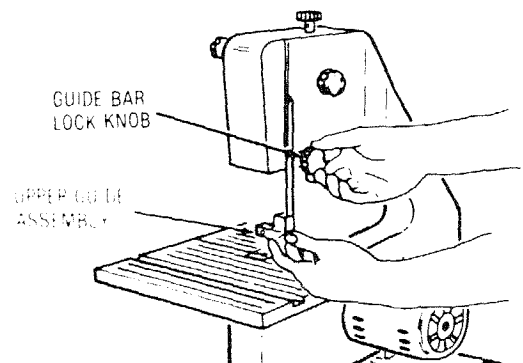

5. Loosen the two screws in the front of the upper blade guide assembly that secure the blade guides and separate them about 1/8".
6. Loosen the two screws in the side of the upper guide assembly and slide guides and thrust bearing all of the way back.
7. Tighten all screws.

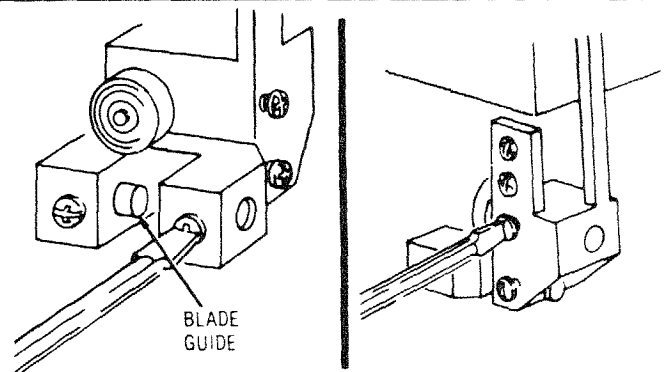

8. Loosen the three (3) cover knobs by turning counterclockwise and remove cover.

NOTE: Replace the bandsaw cover after blade is properly installed, tensioned and tracked.

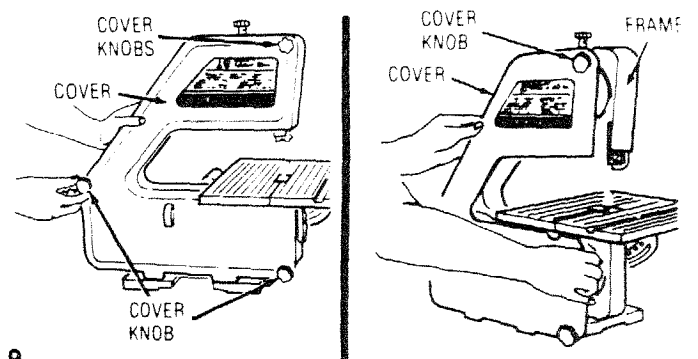

assembly

- Loosen the two screws that secure the lower blade guides and separate them about 1/8".
- Loosen the screw holding the lower blade guide support and slide support all the way toward the rear of the saw, and retighten all screws.

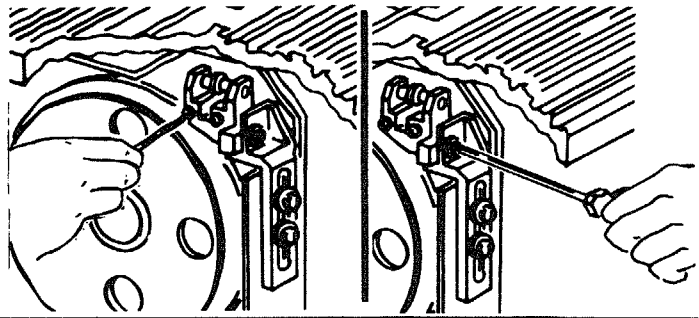

WARNING: TO AVOID BEING SCRAPPED SHOULD BLADE SUDDENLY UNCOIL, WEAR SAFETY GOGGLES AND CAREFULLY UNCOIL THE BLADE HOLDING IT AT ARMS LENGTH.

- Place the blade over the wheels with the teeth pointing downward toward the table as shown. Make sure the blade is in the center of the rubber tires.

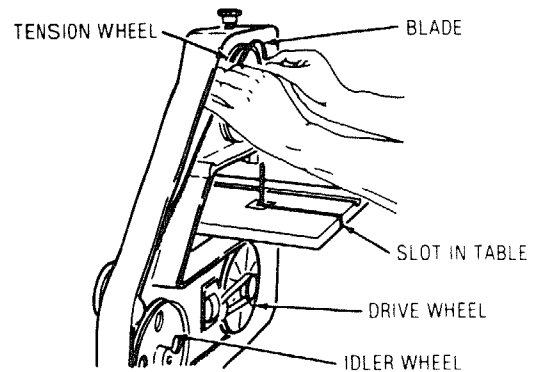

TENSIONING THE BLADE

NOTE: Your bandsaw can use only 1/4 inch wide blades, 56-7/8 inches long. A blade is included with this saw.

- Loosen the tension lock knob (1/4 of a turn counter-clockwise). Turn the tension adjusting knob clockwise until blade has proper tension. To check blade tension, push thumb against side of blade between lower wheels. Blade should move only slightly with moderate pressure. Be careful not to overtension blade. Retighten tension lock knob.
- If too much blade tension has been applied, blades may tend to break more easily and blade life will be shorter.

If too little blade tension has been applied, blade may not track easily, may slip on wheels, or will move too easily when checking tension.
- Turn the upper wheel by hand clockwise a few turns and notice if the blade remains in the approximate center of the tires.

NOTE: Tension lock knob must be tightened before moving blade.

If the blade moves away from the center of the tires while you are turning the wheels, the blade is not TRACKING properly.

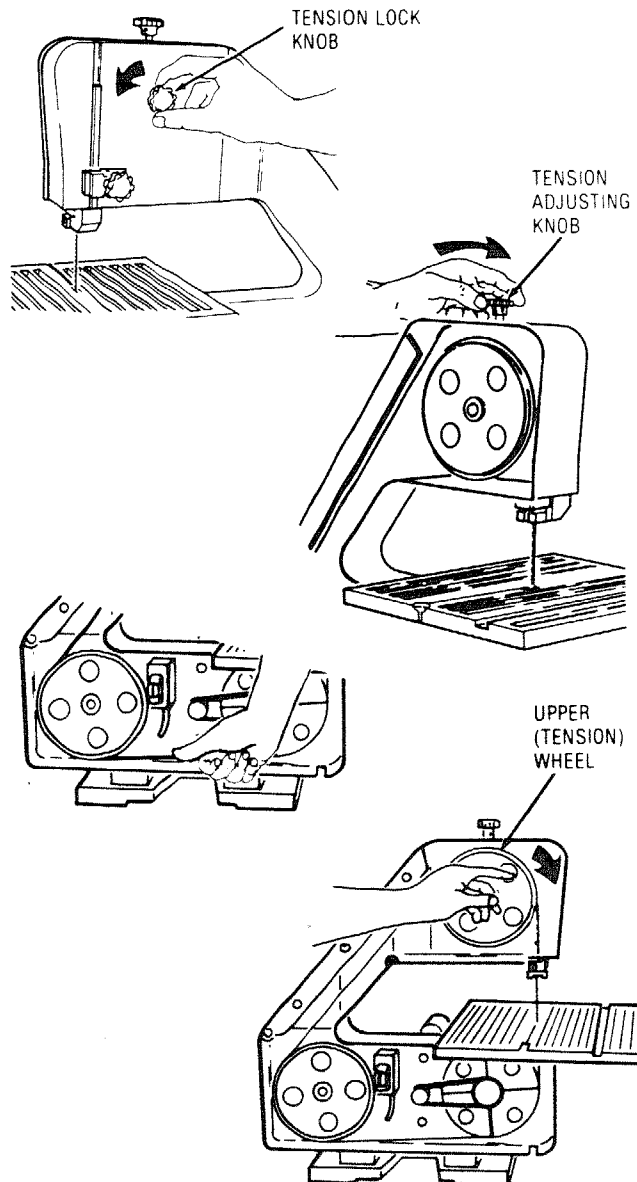

TRACKING THE BLADE

1. Loosen the Tension Lock Knob (1/4 of a turn counter-clockwise) and turn the tracking adjustment set screw slightly with a 1/8" hex wrench. (Turning the set screw moves the tension wheel back and forth.)
2. If the blade moves toward the front of the band saw:
Turn the tracking adjustment screw clockwise about 1/4 of a turn, as though you were tightening it.
If the blade moves toward the back of the band saw:
Turn the tracking adjustment screw counter clockwise about 1/4 of a turn as though you were loosening it.
Turn the screw just enough to cause the blade to run in the approximate center of all tires.
3. After adjusting, tighten tension knob and turn upper wheel by hand clockwise a few turns and notice if the blade remains in the approximate center of the tires, Readjust if necessary, until blade is tracking properly.

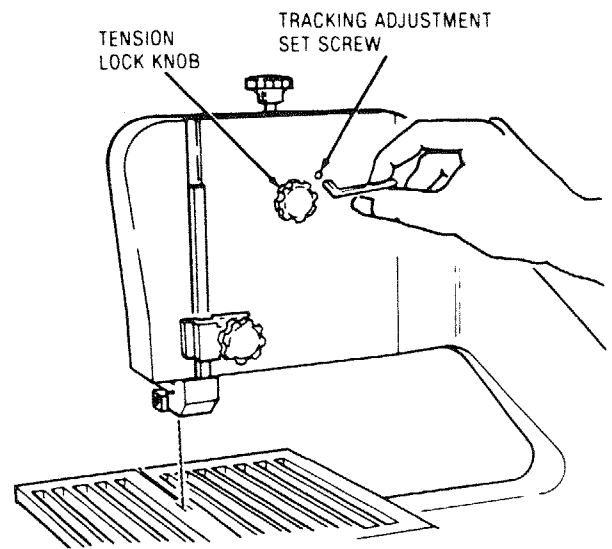

ALIGNING THE TABLE SQUARE TO BLADE

1. Loosen table lock knobs.
2. Place a square on the table in front of the blade as illustrated.
3. Tilt table up or down to align table 90 degrees to blade (0 degree position) and tighten lock knobs.
4. Adjust zero stop set screw using a 1/8" hex wrench until set screw just touches frame.
5. Check squareness of blade to table. Make readjustments if necessary.
6. Set bevel indicator to line up with zero.

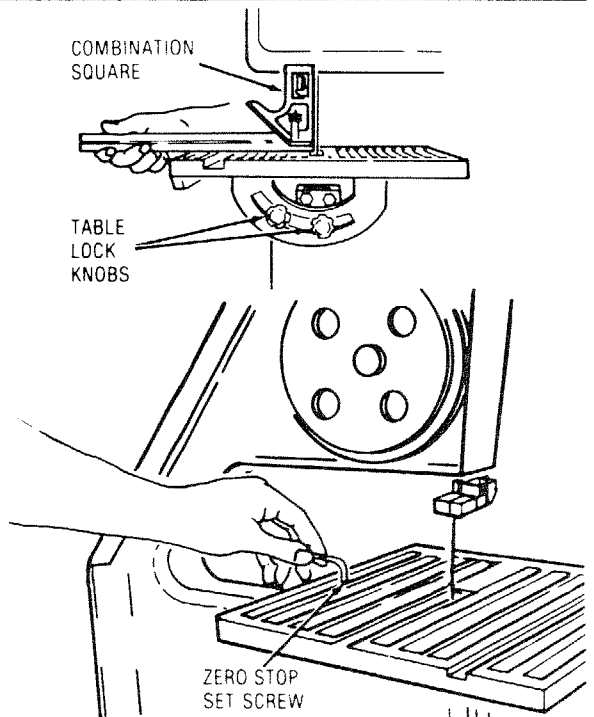

NOTE: When table is tilted to a bevel angle, the lower blade guide support should be lowered to clear the table. After bevel cutting and returning table to zero position, always raise the lower blade guide up to provide maximum support for the blade.

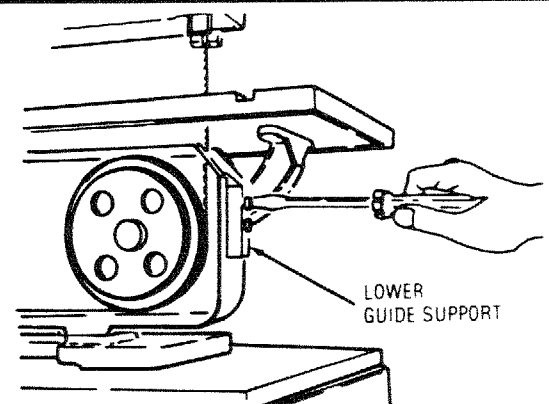

assembly

NOTE: The upper and lower blade guides support the blade and keep it from twisting during operation. An adjustment is necessary when blades are changed, replaced or installed for the first time.

ADJUSTING UPPER BLADE GUIDE ASSEMBLY

1. Loosen lower screw on side of upper blade guide assembly and slide assembly forward until the front edge of the blade guides are approximately $1/32''$ from the GULLET of the saw blade. Tighten screw.

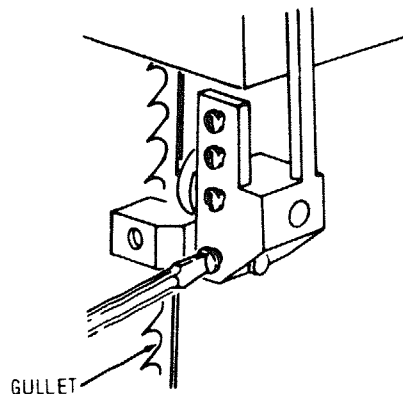

ADJUSTING UPPER BLADE GUIDES

1. Loosen the two screws that lock the upper blade guides and press the two guides evenly against the sides of the blade but do not pinch the blade. Release the guides and rotate the upper wheel slightly clockwise moving the blade downward. Make sure one guide is not further away from the blade than the other. Tighten both screws.

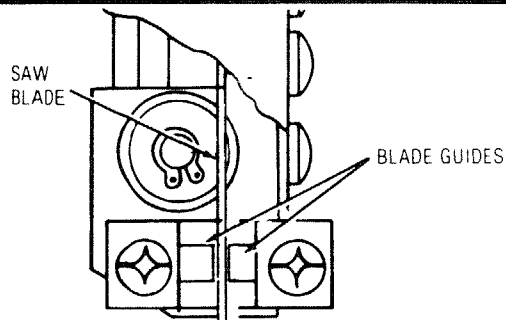

ADJUSTING UPPER THRUST BEARING

NOTE: The thrust bearing supports the blade from the rear and will rotate when the blade is pushed against it while you are cutting. As soon as you stop cutting, the bearing should stop rotating.

1. To adjust, loosen the upper screw on the side of the upper blade guide assembly and slide the bearing forward until it is approximately $1/32''$ from the back of the blade. Tighten screw. Rotate upper wheel slightly clockwise to check clearance. Readjust if necessary.

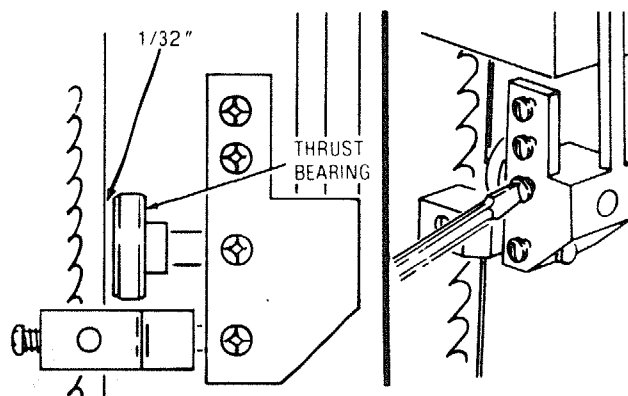

ADJUSTING LOWER BLADE GUIDE ASSEMBLY

1. Loosen the screw (as shown) on the side of the lower blade guide assembly and slide assembly forward until bearing is approximately $1/32''$ from the back of the blade. Blade guides will align with this adjustment. Tighten screw.

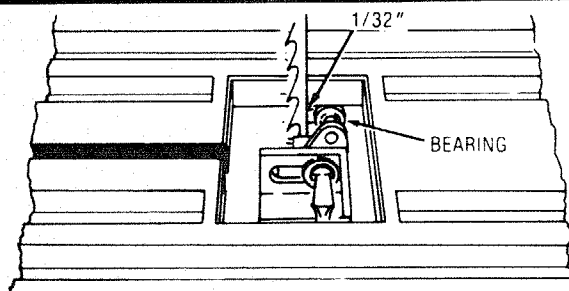

ADJUSTING LOWER BLADE GUIDES

1. Loosen the two screws that lock the lower blade guides and press the two guides evenly against the sides of the blade but do not pinch the blade. Release the guides and rotate the upper wheel slightly clockwise moving the blade downward. Make sure one guide is not further away from the blade than the other. Tighten both screws.

NOTE: After all adjustments have been made, turn the upper wheel by hand (clockwise) a few turns to check blade travel and clearance.

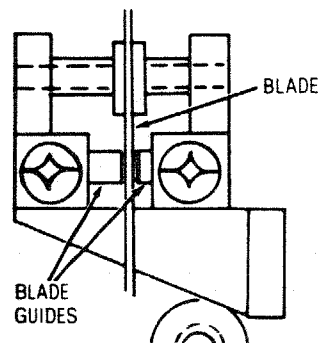

DRIVE BELT TENSION

WARNING: TO AVOID INJURY DUE TO ACCIDENTAL START, UNPLUG TOOL BEFORE MAKING ADJUSTMENTS.

The tension on the drive belt has been set at the factory. If adjustment is needed, use a 3/16" hex wrench to loosen upper and lower cap screws. Pull motor away from drive wheel to apply proper tension to drive belt. Retighten cap screw while holding motor in place.

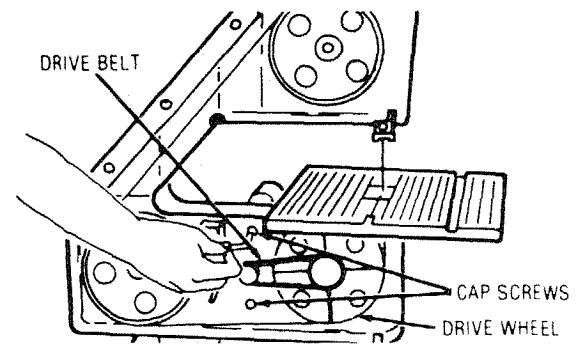

ADJUSTING THE TABLE

1. Replace the blade guard on the upper assembly and tighten screws.
2. Locate the table insert and place it in the opening in the table. Align slot in the insert with the slot in the table.
3. Locate a 1/4 - 20 x 3/4" truss head screw, a flat washer, and a 1/4 - 20 wing nut in loose parts. Insert screw into hole in table top as illustrated.
4. From the underside of the table, install washer and wing nut onto the truss head screw and tighten finger tight. This will keep the table flat and in alignment.
5. Replace the band saw cover.

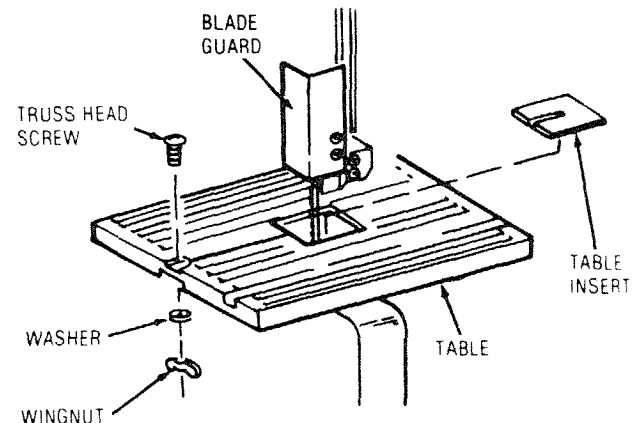

getting to know your band saw

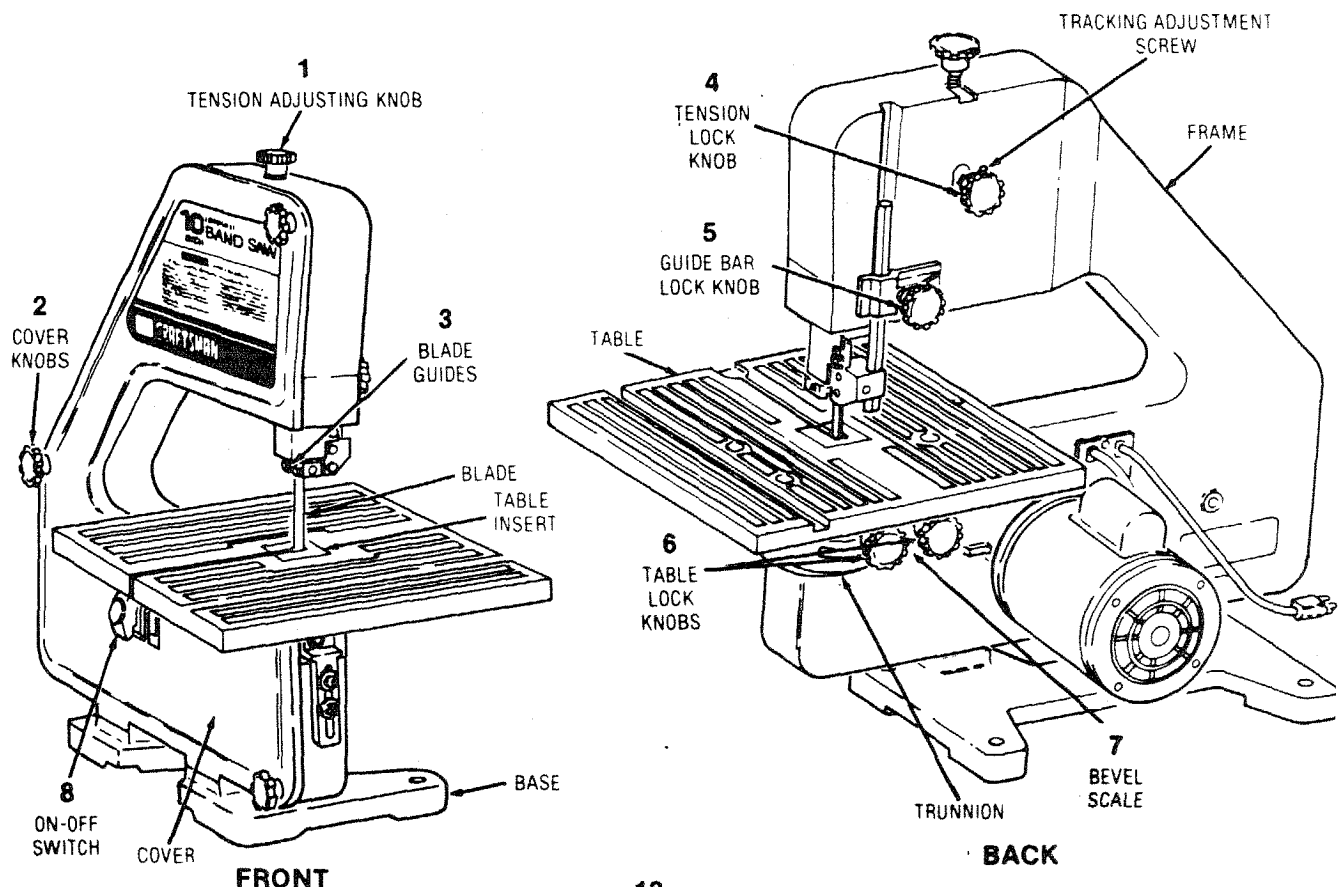

getting to know your band saw

1. Tension adjusting knob... Tightening the knob (clockwise) will increase the tension on the blade. Loosening it (counter clockwise) will decrease the tension. (Tension lock knob must be released).
2. Cover knobs... Secure cover to frame by tightening all three (3) cover knobs.
3. Blade Guides... Supports the blade and keeps it from twisting during operation. An adjustment is necessary when blades are changed or replaced.
4. Tension lock knob... Holds position of the upper wheel which is set by the tension adjusting knob.
5. Guide bar lock knob... The upper blade guide assembly should just clear the workpiece while cutting. Always adjust the upper guide assembly and lock the guide bar by tightening the blade guide lock knob before turning on the band saw.
6. Table lock knobs... Loosening knobs allows the table to be tilted and tightening knobs locks the table in place.
7. Tilt (bevel) scale... Shows degree table is tilted for bevel cutting.

8. **ON-OFF SWITCH.** The On-Off Switch has a locking feature. THIS FEATURE IS INTENDED TO HELP PREVENT UNAUTHORIZED AND POSSIBLY HAZARDOUS USE BY CHILDREN AND OTHERS.

1. To turn machine on insert key into switch.

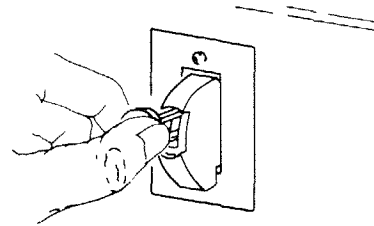

NOTE: Key is made of yellow plastic; locate in loose parts bag.

2. Insert finger under switch lever and pull end of switch out.

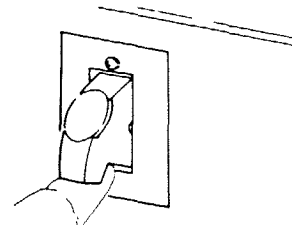

3. To turn machine OFF... PUSH lever in.

NEVER LEAVE THE MACHINE UNATTENDED UNTIL IT HAS COME TO A COMPLETE STOP.

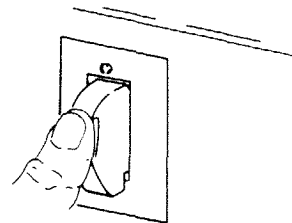

4. To lock switch in OFF position... hold switch IN with one hand... REMOVE key with other hand.

WARNING: FOR YOUR OWN SAFETY, ALWAYS LOCK THE SWITCH "OFF" WHEN MACHINE IS NOT IN USE... REMOVE KEY AND KEEP IT IN A SAFE PLACE... ALSO... IN THE EVENT OF A POWER FAILURE (ALL OF YOUR LIGHTS GO OUT) TURN SWITCH OFF... REMOVE THE KEY AND STORE IT REMOTE FROM BAND SAW. THIS WILL PREVENT THE MACHINE FROM STARTING UP AGAIN WHEN THE POWER COMES BACK ON.

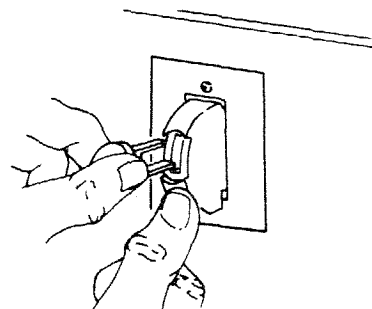

basic band saw operation

A band saw is basically a "curve cutting" machine. It is also used for straight-line cutting operations such as cross cutting, ripping, mitering, beveling, compound cutting, and resawing. It is not capable of doing inside cutting.

This band saw is designed to cut wood and wood like products only.

For general type scroll cutting, follow the pattern lines by pushing and turning the workpiece at the same time. Do not try to turn the workpiece while engaged in the blade without pushing it; the workpiece could bind or twist the blade.

A curve cut is best performed by keeping the pattern line in line with the blade while turning the workpiece **before** the radius of the curve is cut. The blade should cut in the middle of the pattern line (saw kerf) since wood cutting band saw blades are thin.

NOTE: Blade guard is raised for clarity of picture only.

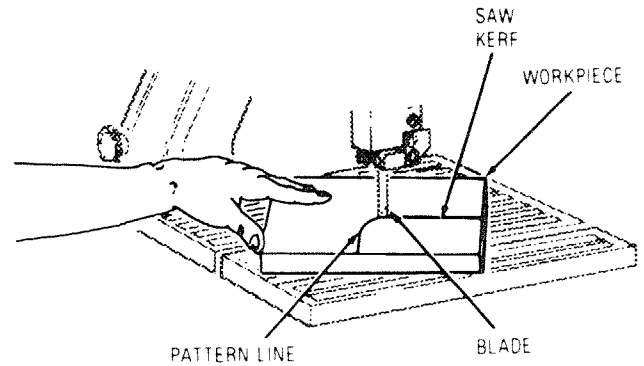

RIGHT - Planning ahead by turning workpiece for cutting a curve.

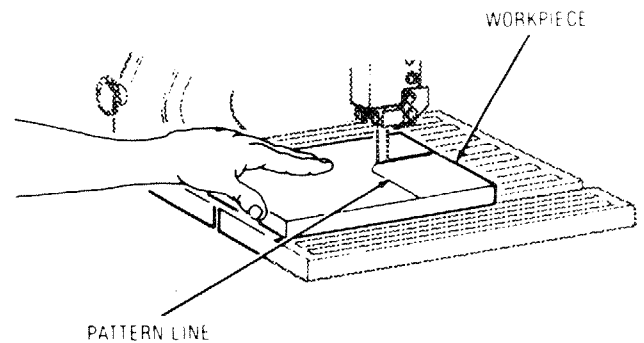

WRONG - Not planning ahead for cutting a curve could bind or twist blade if workpiece is forced.

SAWING

1. Adjust the upper guide assembly to just clear the workpiece.
2. Use both hands while feeding the work into the blade. Hold the workpiece firmly against the table. Use gentle pressure. Do not force the work, but allow the blade to cut.
3. The smallest diameter circle that can be cut out is determined by the width of the blade. A 1/4" wide blade will cut a minimum diameter of approximately 1-1/2".

Relief cuts are made when an intricate curve (too small a radius for a 1/4-inch blade) is to be cut. A relief cut is made by cutting through scrap section of workpiece to curve in pattern line, then carefully backing blade out. Several relief cuts should be made for intricate curves, then follow pattern line as sections are cut off of curve "relieving" blade pressure.

NOTE: Blade guard is raised for clarity of picture only.

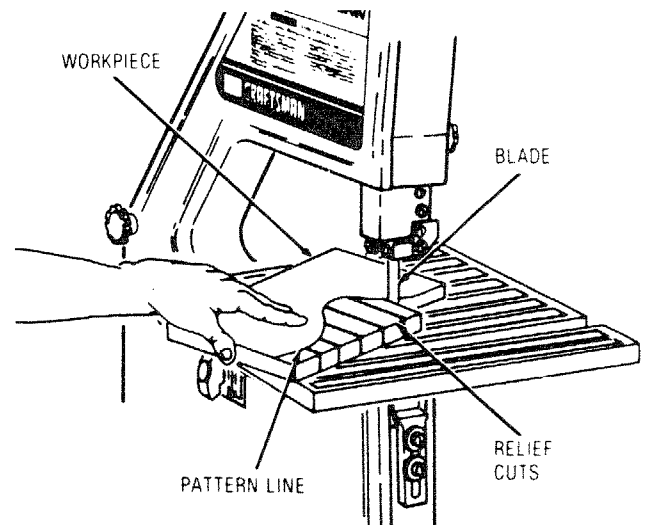

maintenance

WARNING: FOR YOUR OWN SAFETY, TURN SWITCH "OFF" AND REMOVE PLUG FROM POWER OUTLET BEFORE MAINTAINING OR LUBRICATING YOUR BAND SAW.

TIRES

Pitch and sawdust that accumulate on the tires should be removed with a stiff brush or scraped off with a piece of wood. Do not use a sharp knife or any kind of solvent.

When the tires become worn they should be replaced. When replacing the tires, put a thin layer of rubber cement on the outside of the wheels and inside of the tires. Allow to dry, then slide tires onto wheels aligning tires inside wheel edges.

GENERAL

Keep your Band Saw clean.

Remove sawdust from the inside frequently.

Do not allow pitch to accumulate on the table, blade insert, blade guides, or thrust bearings. Clean them with Craftsman Gum and Pitch Remover.

Apply a thin coat of automobile-type wax to the table so the wood slides easily while cutting. Also apply wax to the inside surfaces of the trunnion.

MOTOR/ELECTRICAL

Frequently vacuum or blow out any sawdust from the motor.

If the power cord is worn, cut, or damaged in any way, have it replaced immediately.

LUBRICATION

All of the BALL BEARINGS are permanently lubricated. They require no further lubrication.

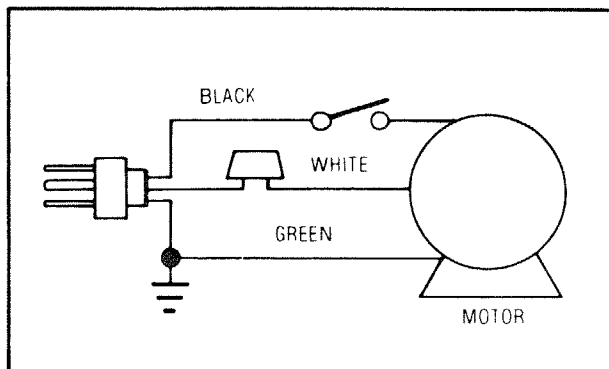

RECOMMENDED ACCESSORIES

Item	Cat. No.
Miter Gauge	9-24214
Blades (56-7/8" length).....	See Catalog

The above recommended accessories are current and were available at the time this manual was printed.

troubleshooting

WARNING: FOR YOUR OWN SAFETY, TURN SWITCH "OFF" AND REMOVE PLUG FROM POWER OUTLET BEFORE READJUSTING OR ALIGNING YOUR BAND SAW.

TROUBLE	PROBABLE CAUSE	REMEDY
Motor will not run.	<ol style="list-style-type: none"> 1. Defective On-Off switch. Defective power or motor cord. 2. Motor Defective. 	<ol style="list-style-type: none"> 1. Replace defective parts before using Band Saw again. 2. Consult Sears Service. Any attempt to repair this motor may create a HAZARD unless repair is done by a qualified service technician. Repair service is available at your nearest Sears Store.
Blade does not run in the approximate center of the upper wheel.	<ol style="list-style-type: none"> 1. Not tracking properly. 	<ol style="list-style-type: none"> 1. Adjust tracking, see Assembly Section, "Tracking the Blade."
Band Saw slows down when cutting.	<ol style="list-style-type: none"> 1. Cutting too small a radius. 2. Dull blade. 	<ol style="list-style-type: none"> 1. Stop feeding, and back up the material slightly, until the band saw speeds up. 2. Replace blade.
Blades breaking.	<ol style="list-style-type: none"> 1. Too much tension. 2. Kink in blade caused by cutting too small a radius or turning the material too fast when cutting. 	<ol style="list-style-type: none"> 1. Adjust tension. See Assembly section "Tensioning The Blade." 2. Use correct cutting technique. See Basic Band Saw Operation Section.
Motor sounds under load when not cutting.	<ol style="list-style-type: none"> 1. Too much blade tension. 2. Too much belt tension. 	<ol style="list-style-type: none"> 1. Adjust blade tension. See Assembly section "Tensioning The Blade." 2. Adjust belt tension. See Assembly Section "Drive Belt Tension."
Blade will not allow for general straight cutting.	<ol style="list-style-type: none"> 1. Blade guides and bearings not properly adjusted. 2. Defective blade. 	<ol style="list-style-type: none"> 1. Adjust upper and lower blade guides and bearings. See Assembly section "Adjusting Upper Blade Guide Assembly." 2. Replace blade.

PARTS LIST FOR CRAFTSMAN 10 INCH MOTORIZED BANDSAW MODEL NO. 113.244512

repair parts

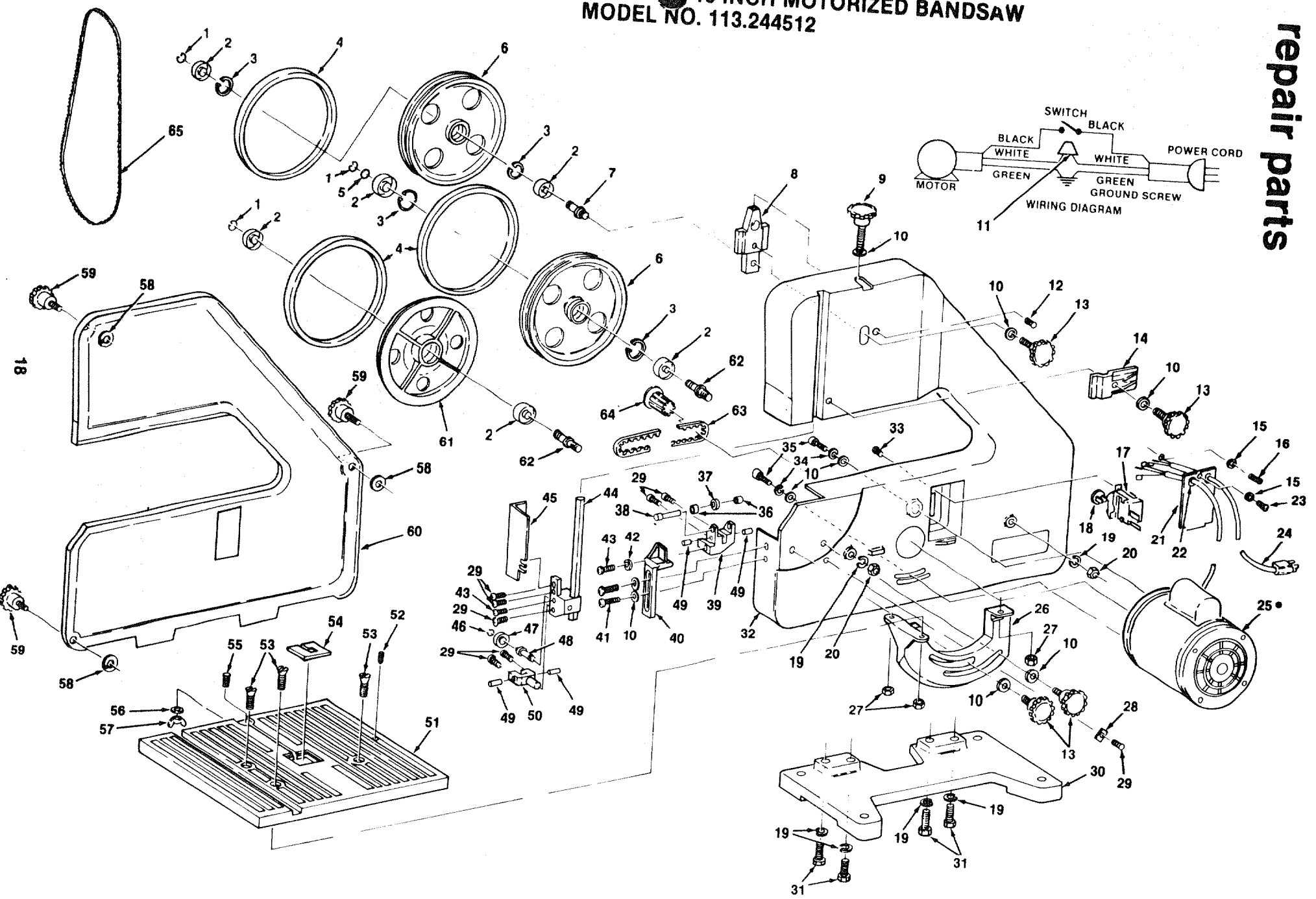

**PARTS LIST FOR CRAFTSMAN 10 INCH MOTORIZED BANDSAW
MODEL NO. 113.244512**

ALWAYS ORDER BY PART NO. AND DESCRIPTION - NOT BY KEY NO.

Key No.	Part No.	Description
1	69165	Ring-Retaining 5160
2	STD315505	*Bearing-Ball
3	69166	Ring-Retaining 5000
4	69177	Tire
5	814351	Washer-Plastic
6	69179	Wheel-Idler
7	69170	Shaft-Upper Wheel
8	69154	Guide-Wheel
9	69158	Knob
10	STD551025	*Washer 17/64x47/64x1/16
11	803709	Connector Wire
12	STD502503	*Screw-Set Hex Cup 1/4-20x3/8
13	69157	Knob
14	69146	Clamp-Guide Rod
15	STD551208	*Lockwasher-Ext. #8
16	STD600803	*Screw-Pan Cross 8-32x3/8
17	62442	Switch-Locking
18	60256	Switch-Key
19	STD551131	*Lockwasher-5/16
20	STD541031	*Nut-Hex 5/16-18
21	69149	Cover-Switch
22	69164	Relief Strain
23	STD510802	*Screw-Pan HD. 8-32x5/16
24	69147	Cord-Power
25	69161	•Motor
26	69178	Trunnion
27	STD541025	*Nut Hex 1/4-20
28	69155	Indicator Bevel
29	STD511003	*Screw-Pan Cross 10-24x3/8
30	69150	Foot-Frame
31	STD523115	*Screw-Hex Hd. 5/16-18x1 1/2
32	69151	Frame
33	STD510603	*Screw-Pan Hd. 6-32x3/8
34	STD551125	*Lockwasher-1/4

Key No.	Part No.	Description
35	60102	Screw-Soc. Cap. 1/4-20x1
36	69172	Spacer
37	60528	Bearing-Ball
38	69169	Shaft-Guide Support
39	69174	Support-Lower Guide
40	69175	Support-Guide
41	STD512507	*Screw-Pan Cross 1/4-20x3/4
42	STD551010	*Washer 13/64x1/2x3/64
43	STD511005	*Screw-Pan Cross 10-24x1/2
44	69167	Rod-Guide Support
45	69152	Guard-Blade
46	69163	Ring-Retaining
47	60529	Bearing-Ball
48	69171	Shaft-Upper Guide
49	69153	Guide
50	69173	Support-Upper Guide
51	69176	Table-Band Saw
52	60531	Screw-Locking Set 1/4-20x5/8
53	60532	Screw-Flat Cross 1/4x20x1
54	69156	Insert-Table
55	60530	Screw-Truss Hd. 1/4-20x3/4
56	9414920	Washer 17/64x5/8x1/16
57	STD541625	*Nut-Wing 1/4-20
58	60533	Ring-Retaining
59	69160	Knob
60	69148	Cover-Frame
61	69180	Wheel-Drive
62	69168	Shaft-Wheel
63	69144	Belt-Timing
64	69162	Pulley-Timing Belt
65	69145	Blade-Band Saw (56-7/8" Long)
—	69188	Owners Manual (Not Ills.)
—	69189	Bag Of Loose Parts (Not Ills.)

- Any attempt to repair this motor may create a hazard unless repair is done by a qualified service technician. Repair service is available at your nearest Sears store.

* Standard Hardware Items - May Be Purchased Locally



**owners
manual**

SERVICE

**MODEL NO.
113.244512**

**HOW TO ORDER
REPAIR PARTS**

10-INCH BAND SAW

Now that you have purchased your 10-Inch Band Saw should a need ever exist for repair parts or service, simply contact any Sears Service Center and most Sears, Roebuck and Co. stores. Be sure to provide all pertinent facts when you call or visit.

The model number of your 10-Inch Band Saw will be found on a plate at the right-hand side of the saw.

**WHEN ORDERING REPAIR PARTS, ALWAYS
GIVE THE FOLLOWING INFORMATION:**

PART NUMBER	PART DESCRIPTION
MODEL NUMBER 113.244512	NAME OF ITEM 10-Inch Band Saw

All parts listed may be ordered from any Sears Service Center and most Sears stores. If the parts you need are not stocked locally, your order will be electronically transmitted to a Sears Repair Parts Distribution Center for handling.

Sold by SEARS, ROEBUCK AND CO., Chicago, IL. 60684 U.S.A.