

SONY®

4-105-996-21(1)

Digital Still Camera Instruction Manual

DSC-G3

Before operating the unit, please read this manual thoroughly and retain it for future reference.

Getting started

Shooting/viewing images

Uploading images

Using shooting functions

Using viewing functions

Connecting to other devices

Changing camera settings

GB

Cyber-shot

Owner's Record

The model and serial numbers are located on the bottom. Record the serial number in the space provided below. Refer to these numbers whenever you call upon your Sony dealer regarding this product.

Model No. DSC-G3

Serial No. _____

WARNING

To reduce fire or shock hazard, do not expose the unit to rain or moisture.

For Customers in the U.S.A.

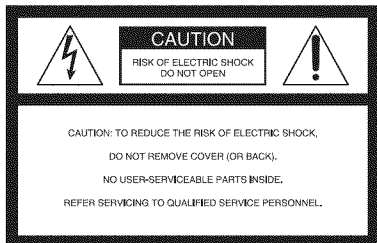

This symbol is intended to alert the user to the presence of uninsulated "dangerous voltage" within the product's enclosure that may be of sufficient magnitude to constitute a risk of electric shock to persons.



This symbol is intended to alert the user to the presence of important operating and maintenance (servicing) instructions in the literature accompanying the appliance.

IMPORTANT SAFEGUARDS

For your protection, please read these safety instructions completely before operating the appliance, and keep this manual for future reference.

Carefully observe all warnings, precautions and instructions on the appliance, or the one described in the operating instructions and adhere to them.

Use

Power Sources

This set should be operated only from the type of power source indicated on the marking label. If you are not sure of the type of electrical power supplied to your home, consult your dealer or local power company. For those sets designed to operate from battery power, or other sources, refer to the operating instructions.

Polarization

This set may be equipped with a polarized ac power cord plug (a plug having one blade wider than the other).

This plug will fit into the power outlet only one way. This is a safety feature. If you are unable to insert the plug fully into the outlet, try reversing the plug. If the plug should still fail to fit, contact your electrician to have a suitable outlet installed. Do not defeat the safety purpose of the polarized plug by forcing it in.

Overloading

Do not overload wall outlets, extension cords or convenience receptacles beyond their capacity, since this can result in fire or electric shock.

Object and Liquid Entry

Never push objects of any kind into the set through openings as they may touch dangerous voltage points or short out parts that could result in a fire or electric shock. Never spill liquid of any kind on the set.

Attachments

Do not use attachments not recommended by the manufacturer, as they may cause hazards.

Cleaning

Unplug the set from the wall outlet before cleaning or polishing it. Do not use liquid cleaners or aerosol cleaners. Use a cloth lightly dampened with water for cleaning the exterior of the set.

Installation

Water and Moisture

Do not use power-line operated sets near water – for example, near a bathtub, washbowl, kitchen sink, or laundry tub, in a wet basement, or near a swimming pool, etc.

Power-Cord Protection

Route the power cord so that it is not likely to be walked on or pinched by items placed upon or against them, paying particular attention to the plugs, receptacles, and the point where the cord exits from the appliance.

Accessories

Do not place the set on an unstable cart, stand, tripod, bracket, or table. The set may fall, causing serious injury to a child or an adult, and serious damage to the set. Use only a cart, stand, tripod, bracket, or table recommended by the manufacturer.

Ventilation

The slots and openings in the cabinet are provided for necessary ventilation. To ensure reliable operation of the set, and to protect it from overheating, these slots and openings must never be blocked or covered.

- Never cover the slots and openings with a cloth or other materials.
- Never block the slots and openings by placing the set on a bed, sofa, rug, or other similar surface.
- Never place the set in a confined space, such as a bookcase, or built-in cabinet, unless proper ventilation is provided.
- Do not place the set near or over a radiator or heat register, or where it is exposed to direct sunlight.

Lightning

For added protection for this set during a lightning storm, or when it is left unattended and unused for long periods of time, unplug it from the wall outlet and disconnect the antenna or cable system. This will prevent damage to the set due to lightning and power-line surges.

Service

Damage Requiring Service

Unplug the set from the wall outlet and refer servicing to qualified service personnel under the following conditions:

- When the power cord or plug is damaged or frayed.
- If liquid has been spilled or objects have fallen into the set.
- If the set has been exposed to rain or water.
- If the set has been subject to excessive shock by being dropped, or the cabinet has been damaged.
- If the set does not operate normally when following the operating instructions. Adjust only those controls that are specified in the operating instructions. Improper adjustment of other controls may result in damage and will often require extensive work by a qualified technician to restore the set to normal operation.
- When the set exhibits a distinct change in performance – this indicates a need for service.

Servicing

Do not attempt to service the set yourself as opening or removing covers may expose you to dangerous voltage or other hazards.

Refer all servicing to qualified service personnel.

Replacement parts

When replacement parts are required, be sure the service technician has used replacement parts specified by the manufacturer that have the same characteristics as the original parts.

Unauthorized substitutions may result in fire, electric shock, or other hazards.

Safety Check

Upon completion of any service or repairs to the set, ask the service technician to perform routine safety checks (as specified by the manufacturer) to determine that the set is in safe operating condition.

Read this first

CAUTION

Replace the battery with the specified type only. Otherwise, fire or injury may result.

Do not expose the batteries to excessive heat such as sunshine, fire or the like.

For Customers in the U.S.A. and Canada

RECYCLING LITHIUM-ION BATTERIES

Lithium-Ion batteries are recyclable.

You can help preserve our environment by returning your used rechargeable batteries to the collection and recycling location nearest you.



For more information regarding recycling of rechargeable batteries, call toll free 1-800-822-8837, or visit <http://www.rbrcc.org/>

Caution: Do not handle damaged or leaking Lithium-Ion batteries.

Battery charger

This power unit is intended to be correctly orientated in a vertical or floor mount position.

This device complies with Part 15 of the FCC Rules and RSS-Gen of IC Rules. Operation is subject to the following two conditions: (1) This device may not cause harmful interference, and (2) this device must accept any interference received, including interference that may cause undesired operation.

This Class B digital apparatus complies with Canadian ICES-003.

IMPORTANT NOTE

To comply with FCC RF exposure requirements, the following antenna installation and device operating configurations must be satisfied: the antenna has been installed by the manufacturer and no change can be made.

This device and its antenna(s) must not be co-located or operating in conjunction with any other antenna or transmitter.

For Customers in the U.S.A.

The available scientific evidence does not show that any health problems are associated with using low power wireless devices. There is no proof, however, that these low power wireless devices are absolutely safe. Low power Wireless devices emit low levels of radio frequency energy (RF) in the microwave range while being used. Whereas high levels of RF can produce health effects (by heating tissue), exposure to low-level RF that does not produce heating effects causes no known adverse health effects. Many studies of low-level RF exposures have not found any biological effects. Some studies have suggested that some biological effects might occur, but such findings have not been confirmed by additional research. DSC-G3 has been tested and found to comply with FCC radiation exposure limits set forth for an uncontrolled equipment and meets the FCC radio frequency (RF) Exposure Guidelines in Supplement C to OET65.

If you have any questions about this product, you may call:

Sony Customer Information Center
1-800-222-SONY (7669)

The number below is for the FCC related matters only.

Regulatory Information

Declaration of Conformity

Trade Name: SONY
Model No.: DSC-G3
Responsible Party: Sony Electronics Inc.
Address: 16530 Via Esprillo,
San Diego, CA 92127 U.S.A.
Telephone No.: 858-942-2230

This device complies with Part 15 of the FCC Rules. Operation is subject to the following two conditions: (1) This device may not cause harmful interference, and (2) this device must accept any interference received, including interference that may cause undesired operation.

CAUTION

You are cautioned that any changes or modifications not expressly approved in this manual could void your authority to operate this equipment.

Note:

This equipment has been tested and found to comply with the limits for a Class B digital device, pursuant to Part 15 of the FCC Rules. These limits are designed to provide reasonable protection against harmful interference in a residential installation. This equipment generates, uses, and can radiate radio frequency energy and, if not installed and used in accordance with the instructions, may cause harmful interference to radio communications. However, there is no guarantee that interference will not occur in a particular installation. If this equipment does cause harmful interference to radio or television reception, which can be determined by turning the equipment off and on, the user is encouraged to try to correct the interference by one or more of the following measures:

- Reorient or relocate the receiving antenna.
- Increase the separation between the equipment and receiver.
- Connect the equipment into an outlet on a circuit different from that to which the receiver is connected.
- Consult the dealer or an experienced radio/TV technician for help.

The supplied interface cable must be used with the equipment in order to comply with the limits for a digital device pursuant to Subpart B of Part 15 of FCC Rules.

For Customers in Europe

Hereby, Sony Corporation, declares that this DSC-G3 Digital Still Camera is in compliance with the essential requirements and other relevant provisions of the Directive 1999/5/EC. For details, please access the following URL: <http://www.compliance.sony.de/>



This product has been tested and found compliant with the limits set out in the EMC regulation for using connection cables shorter than 3 meters (9.8 feet).

Attention

The electromagnetic fields at the specific frequencies may influence the picture and sound of this unit.

Notice

If static electricity or electromagnetism causes data transfer to discontinue midway (fail), restart the application or disconnect and connect the communication cable (USB, etc.) again.

Disposal of Old Electrical & Electronic Equipment (Applicable in the European Union and other European countries with separate collection systems)



This symbol on the product or on its packaging indicates that this product shall not be treated as household waste. Instead it shall be handed over to the applicable collection point for the recycling of electrical and electronic equipment. By ensuring this product is disposed of correctly, you will help prevent potential negative consequences for the environment and human health, which could otherwise be caused by inappropriate waste handling of this product. The recycling of materials will help to conserve natural resources. For more detailed information about recycling of this product, please contact your local Civic Office, your household waste disposal service or the shop where you purchased the product.

Disposal of waste batteries (applicable in the European Union and other European countries with separate collection systems)

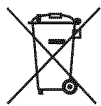

This symbol on the battery or on the packaging indicates that the battery provided with this product shall not be treated as household waste.

By ensuring these batteries are disposed of correctly, you will help prevent potentially negative consequences for the environment and human health which could otherwise be caused by inappropriate waste handling of the battery. The recycling of the materials will help to conserve natural resources.

In case of products that for safety, performance or data integrity reasons require a permanent connection with an incorporated battery, this battery should be replaced by qualified service staff only.



To ensure that the battery will be treated properly, hand over the product at end-of-life to the applicable collection point for the recycling of electrical and electronic equipment.

For all other batteries, please view the section on how to remove the battery from the product safely. Hand the battery over to the applicable collection point for the recycling of waste batteries.

For more detailed information about recycling of this product or battery, please contact your local Civic Office, your household waste disposal service or the shop where you purchased the product.

Notice for customers in the United Kingdom

A moulded plug complying with BS 1363 is fitted to this equipment for your safety and convenience.

Should the fuse in the plug supplied need to be replaced, a fuse of the same rating as the supplied one and approved by ASTA or BSI to BS 1362, (i.e., marked with an  or  mark) must be used.

If the plug supplied with this equipment has a detachable fuse cover, be sure to attach the fuse cover after you change the fuse. Never use the plug without the fuse cover. If you should lose the fuse cover, please contact your nearest Sony service station.

For use in Norway

Use of this radio equipment is not allowed in the geographical area within a radius of 20 km from the centre of Ny-Alesund, Svalbard.

For use in Cyprus

The end user must register the RLAN (or WAS or WiFi) devices in the Department of Electronic Communications (P.I. 6/2006 and P.I. 6A/2006). P.I. 6/2006 is the Radiocommunications (Categories of Stations Subject to General Authorization and Registration) Order of 2006. P.I. 6A/2006 is the General Authorization for the use of Radiofrequencies by Radio Local area Networks and by Wireless Access Systems, including Radio Local Area Networks (WAS/RLAN).

Table of contents

IMPORTANT SAFEGUARDS	2
Read this first	4
Notes on using the camera	9

Getting started

11

Checking the accessories supplied	11
Identifying parts	12
Charging the battery pack	13
Inserting the battery pack	15
Setting the clock	17
Setting the wireless network	18

Shooting/viewing images

20

Shooting images	20
Viewing images	21
Storing images	22

Uploading images

23

Uploading images via wireless connection	23
--	----

Using shooting functions

25

Selecting the desired shooting mode	25
Detecting smiles and shooting automatically (Smile Shutter)	26
Detecting the shooting conditions automatically (Scene Recognition)	27
Shooting close-ups (Macro/Close focus)	28
Using the self-timer	28
Selecting a flash mode	29
Focusing on a specific point of the frame	30
Focusing on the face of the subject (Face Detection)	30
Selecting the image size to match the usage	31

Using viewing functions	33
Viewing an enlarged image (Playback zoom)	33
Displaying images full-screen (Wide Zoom).....	33
Rotating a vertical orientation image (Temporarily rotated display).....	34
Viewing still images with music (Slideshow).....	34
Viewing images with the Scrapbook display	35
Searching for an image (Image Index).....	36
Selecting the display format (View Mode).....	36

Connecting to other devices	38
Viewing images on "BRAVIA"	38
Sending images to "BRAVIA"	39
Viewing images on a TV	41
Using the camera with a computer.....	42

Changing camera settings	47
Changing the screen display.....	47
Setting the password lock for the internal memory	48
Using the HOME screen	49
Using the MENU items.....	52
Using functions in Program Auto mode.....	54

Others	55
Viewing "Cyber-shot Handbook"	55
List of icons displayed on the screen	56
Troubleshooting	58
Precautions	61
Specifications	62

■ Notes on using the camera

Internal memory and “Memory Stick Duo” back up

Do not turn off the camera, remove the battery pack, or remove the “Memory Stick Duo” while the access lamp is lit. Otherwise, the internal memory data or “Memory Stick Duo” may be damaged. Be sure to make a backup copy to protect your data.

On management files

When you insert a “Memory Stick Duo” without a management file into the camera and turn on the power, part of the “Memory Stick Duo” capacity is used to automatically create a management file. It may take some time until you can perform the next operation.

Notes on recording/playback

- Before you start recording, make a trial recording to make sure that the camera is working correctly.
- The camera is neither dust-proof, nor splash-proof, nor water-proof. Read “Precautions” (page 61) before operating the camera.
- Avoid exposing the camera to water. If water enters inside the camera, a malfunction may occur. In some cases, the camera cannot be repaired.
- Do not aim the camera at the sun or other bright light. It may cause the malfunction of the camera.
- Do not use the camera near a location that generates strong radio waves or emits radiation. Otherwise, the camera may not properly record or play back images.
- Using the camera in sandy or dusty locations may cause malfunctions.
- If moisture condensation occurs, remove it before using the camera (page 61).
- Do not shake or strike the camera. It may cause a malfunction and you may not be able to record images. Furthermore, the recording media may become unusable or image data may be damaged.
- Clean the flash surface before use. The heat of flash emission may cause dirt on the flash surface to become discolored or to stick to the flash surface, resulting in insufficient light emission.

Notes on the LCD screen

- The LCD screen is manufactured using extremely high-precision technology so over 99.99% of the pixels are operational for effective use. However, some tiny black and/or bright dots (white, red, blue or green) may appear on the LCD screen. These dots are a normal result of the manufacturing process, and do not affect the recording.
- If water droplets or other liquids splash on the LCD screen and make it wet, immediately wipe off the screen with a soft cloth. Leaving liquids on the LCD screen surface can harm the quality and cause a malfunction.

On image data compatibility

- The camera conforms with DCF (Design rule for Camera File system) universal standard established by JEITA (Japan Electronics and Information Technology Industries Association).
- Sony does not guarantee that the camera will play back images recorded or edited with other equipment, or that other equipment will play back images recorded with the camera.

Warning on copyright

Television programs, films, videotapes, and other materials may be copyrighted. Unauthorized recording of such materials may be contrary to the provisions of the copyright laws.

No compensation for damaged content or recording failure

Sony cannot compensate for failure to record or loss or damage of recorded content due to a malfunction of the camera or recording media, etc.

On wireless network function

- The wireless network function built into this camera has been confirmed to conform with Wi-Fi specifications set forth by the Wi-Fi Alliance (WFA).

- The web browser does not necessary work with all wireless access points or with all home pages. Depending on the region, access to a wireless LAN may not be available, may require a separate service charge, or communications may be blocked or suffer from intermittent outages. For details, check with your wireless LAN administrator and/or service provider.
- Sony makes no guarantees whatsoever in the provision of the web browser. Sony bears absolutely no responsibility for damages that may arise from the use of the web browser even in the case of claims made by a third-party.

Security precautions when using wireless network products

Security settings are absolutely critical when using a wireless network.

Sony bears no responsibility for any damages that may arise due to security problems occurring due to failure to implement security measures or unavoidable circumstances associated with the use of a wireless network.

Checking the accessories supplied

- Battery charger BC-CSD (1)

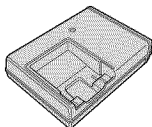

- Power cord (mains lead) (1)
(not supplied in the USA and Canada)



- Rechargeable battery pack NP-BD1 (1)/
Battery case (1)

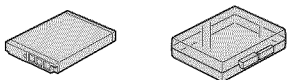

- Paint pen (1)

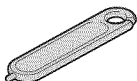

- USB, A/V cable for multi-use terminal (1)

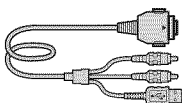

- Wrist strap (1)



- Station plate H (1)
The station plate is used when mounting the camera on Cyber-Shot Station (not supplied).

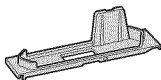

- CD-ROM (1)
 - Cyber-shot application software
 - “Cyber-shot Handbook”
 - “Cyber-shot Step-up Guide”
- Instruction Manual (this manual) (1)

Using the wrist strap

Attach the strap and place your hand through the loop to prevent the camera from damage by being dropped.

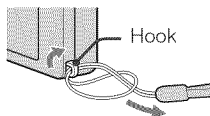

Using the paint pen

The paint pen is used when operating the touch panel. It attaches to the wrist strap.

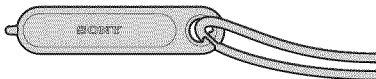

Note

- Do not carry the camera by holding the paint pen. The camera may fall off.

Identifying parts

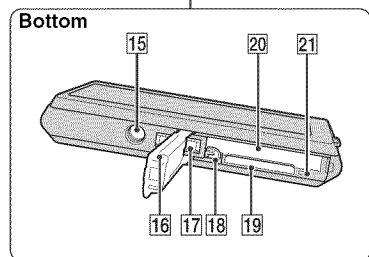
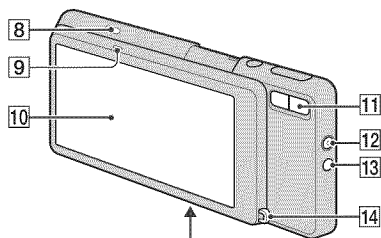
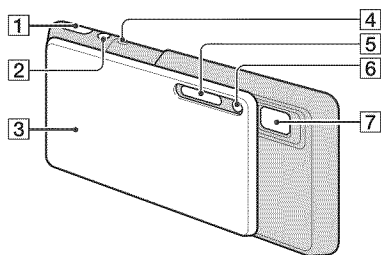

- 1 Shutter button
- 2 ▶ (Playback) button
- 3 Lens cover
- 4 Microphone
- 5 Flash
- 6 Self-timer lamp/Smile Shutter lamp/
AF illuminator lamp
- 7 Lens
- 8 WLAN (Wireless network) lamp
- 9 Speaker
- 10 LCD screen/Touch panel
- 11 Zoom (W/T) button
- 12 POWER button/POWER lamp
- 13 WLAN (Wireless network) button
- 14 Hook for wrist strap
- 15 Tripod receptacle
 - Use a tripod with a screw less than 5.5 mm (7/32 inch) long. Otherwise, you cannot firmly secure the camera, and damage to the camera may occur.
- 16 Battery/"Memory Stick Duo" cover
- 17 Multi connector
- 18 Battery eject lever
- 19 "Memory Stick Duo" slot
- 20 Battery insertion slot
- 21 Access lamp

Charging the battery pack

1 Insert the battery pack into the battery charger.

- You can charge the battery even when it is partially charged.

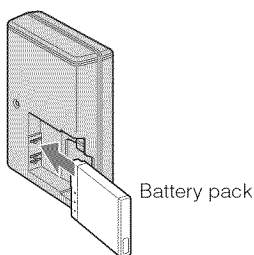

2 Connect the battery charger to the wall outlet (wall socket).

If you continue charging the battery pack for about one more hour after the CHARGE lamp turns off, the charge will last slightly longer (full charge).

CHARGE lamp

Lit: Charging

Off: Charging finished (normal charge)

For customers in the USA and Canada

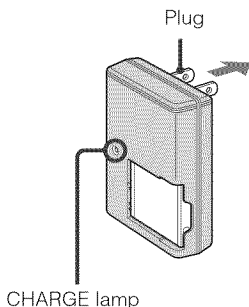

For customers in countries/regions other than the USA and Canada

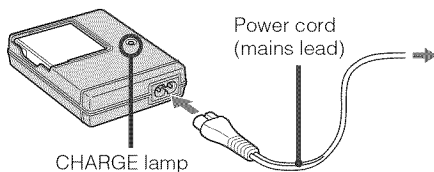

3 When charging is finished, disconnect the battery charger.

Charging time

Full charge time	Normal charge time
Approx. 220 min.	Approx. 160 min.

Notes

- The table above shows the time required to charge a fully depleted battery pack at a temperature of 25°C (77°F). Charging may take longer depending on conditions of use and circumstances.
- Connect the battery charger to the nearest wall outlet (wall socket).
- Even if the CHARGE lamp is not lit, the battery charger is not disconnected from the AC power source (mains) as long as it is connected to the wall outlet (wall socket). If some trouble occurs while using the battery charger, immediately shut off the power by disconnecting the plug from the wall outlet (wall socket).
- When charging is finished, disconnect the power cord (mains lead) from the wall outlet (wall socket), and remove the battery pack from the battery charger.
- Designed for use with compatible Sony batteries.

Battery life and number of images you can record/view

	Battery life (min.)	No. of Images
Shooting still images	Approx. 100	Approx. 200
Viewing still images	Approx. 170	Approx. 3400

- The measurement method is based on the CIPA standard. (CIPA: Camera & Imaging Products Association)

Note

- The battery life and the number of still images may vary depending on the camera settings.



Using the camera abroad

You can use the camera, the battery charger (supplied), and the AC-LS5K AC Adaptor (not supplied) in any country or region where the power supply is within 100 V to 240 V AC, 50/60 Hz.

Do not use an electronic transformer (travel converter). This may cause a malfunction.

Inserting the battery pack

1 Open the cover.

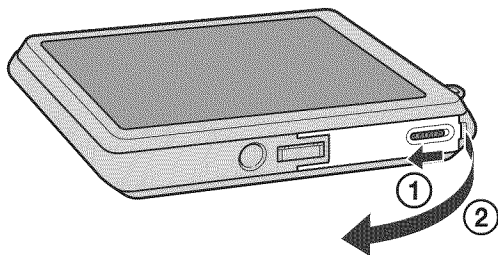

2 Insert the battery pack.

Align the ▲ mark on the battery with the battery eject lever, then insert the battery while pressing the lever in the direction of the arrow.

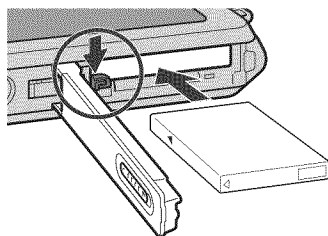

3 Close the cover.

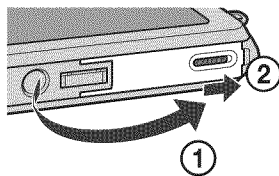

Checking the remaining battery charge

A remaining charge indicator appears on the upper left of the LCD screen.

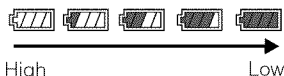

Notes

- It takes about one minute until the correct remaining charge indicator appears.
- The remaining charge indicator may not be correct under certain circumstances.
- If the NP-FD1 battery pack (not supplied) is used, the minute display is also shown after the remaining charge indicator.
- Battery capacity decreases over time and through repeated use. When the operating time per charge decreases markedly, the battery pack needs to be replaced. Purchase a new battery pack.

To remove the battery pack

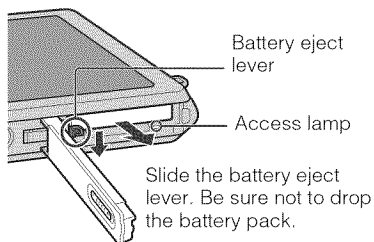

Note

- Never remove the battery pack/“Memory Stick Duo” (not supplied) when the access lamp is lit. This may cause damage to data.

Recording to internal memory

The camera has an approximately 4GB internal memory that allows you to record and play many images even without a “Memory Stick Duo” (not supplied).

Recording to a “Memory Stick Duo”

When a “Memory Stick Duo” is inserted, you can record images to the “Memory Stick Duo” and play images on the “Memory Stick Duo”.

You cannot record or play images on internal memory.

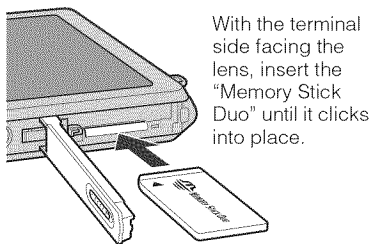

To remove the “Memory Stick Duo”, push the “Memory Stick Duo” in once.

“Memory Stick Duo”



You can also use a “Memory Stick PRO Duo” or “Memory Stick PRO-HG Duo” with the camera.

For details on the number of images/time that can be recorded, see page 32. Other types of “Memory Stick” or memory card are not compatible with the camera.

“Memory Stick”

You cannot use a “Memory Stick” with the camera.



Copying images between recording media

You cannot transfer images between the internal memory and a “Memory Stick Duo” inserted in the camera. Use “PMB” in the CD-ROM (supplied) to move images to the PC and then select the recording media to write the images to. For details, refer to “PMB Guide” after installing “PMB” (page 43).

Setting the clock

- 1 Slide the lens cover as illustrated. Press the frame on the LCD screen with your thumb until it opens fully.

The camera is turned on.

- You can also turn on the camera by pressing the POWER button.

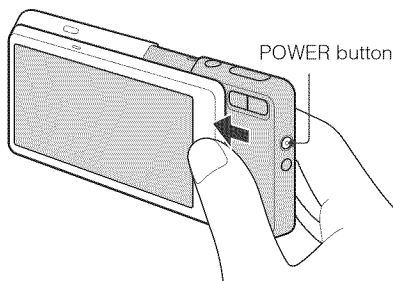

- 2 Touch the desired date display format, then touch \rightarrow .

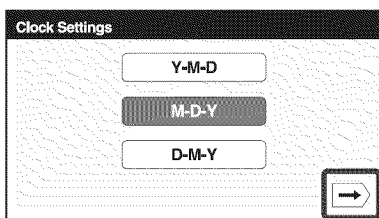

- 3 Touch each item, then touch $\blacktriangle/\blacktriangledown$ to set its numeric value.

- Midnight is indicated as 12:00 AM, and noon as 12:00 PM.

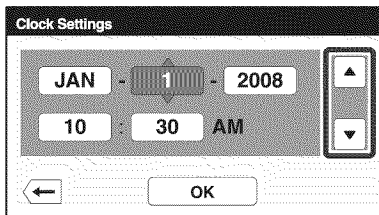

- 4 Touch [OK].

Notes

- The camera does not have a feature for superimposing dates on images. By using “PMB” in the CD-ROM (supplied), you can print or save images with the date.
- If the camera is running on and you do not operate the camera for about three minutes, the camera turns off automatically (Auto power-off function).
- It may take time for the power to turn on and allow operation.

Setting the date and time again

Touch **HOME** \rightarrow  (Settings) \rightarrow [Clock Settings] (page 51).

Setting the wireless network

A wireless LAN function is equipped with this camera.
Connect the camera to a network via an access point.

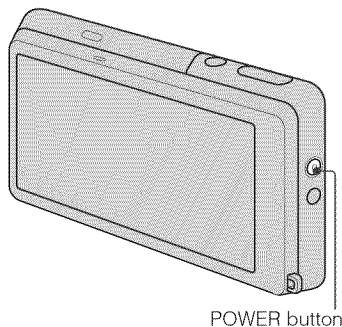

- 1 Press the POWER button to turn on the camera.



- 2 Touch **HOME** →
 (Communication) →
 [Network] → **OK** →
 [Network Settings] →
OK.





- 3 Touch [Time Zone] → **OK** → region in which you live.





- 4 Touch [Access Point] → **OK** → [Create New] → [Auto Scan] →  → access point you want to use → .

The SSID information confirmation screen is displayed.

- 5 Confirm the SSID is displayed → .
- If the SSID is not displayed, select [SSID] → Input using the keyboard → **OK**.

- 6 Select the designated encryption type → .
- If you have selected [Disable], proceed to step 8.

7 Touch [Encryption Key] → Input the encryption key using the keyboard → .

8 Touch [Easy] →  → check your connection name → 
→ check your settings on the confirmation screen →  → [Save] →  → [OK].

Notes

- Network device connections and setting methods differ according to the device.
- The following are needed to connect the camera to a network:
 - An internet service provider (ISP) contract
 - ADSL modem or other network device
 - Access point or wireless router
 - Access point setting information (SSID)
- If you do not know the settings to make, be sure to check with the person who set up the access point, administrator, or with your service provider.
- The auto power-off function does not operate.
- When connected to a network, if you do not operate the camera for about three minutes, the camera may disconnect from the network automatically to save battery power. In these cases establish the connection again.



Using the keyboard

When manual character input is needed, touch the input field to display the keyboard screen. When you are finished with input, touch  on the bottom-right of the screen.

- The input language is the display language of the camera.

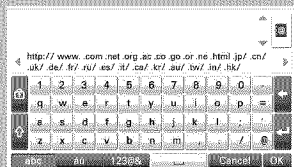

Shooting images

- 1** Slide the lens cover as illustrated.
Press the frame on the LCD screen with your thumb until it opens fully.
The camera is turned on.

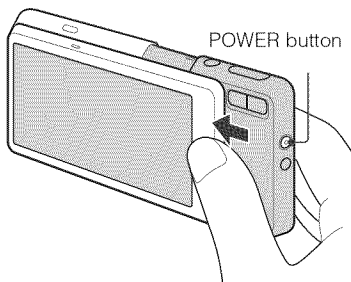

- 2** Hold the camera steady as illustrated.

- Press the T side of the zoom (W/T) button to zoom in. Press the W side to zoom out.

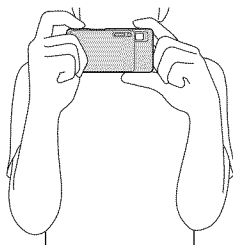

Zoom (W/T) button

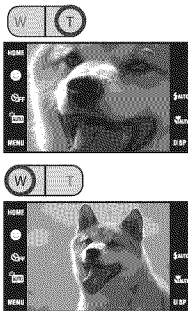

- 3** Press the shutter button halfway down to focus.

 is displayed to indicate that SteadyShot is working. When the image is in focus, a beep sounds and the ● indicator lights.

- The shortest shooting distance is approximately 8 cm (3 1/4 inches) (W)/50 cm (19 3/4 inches) (T) (from the lens).

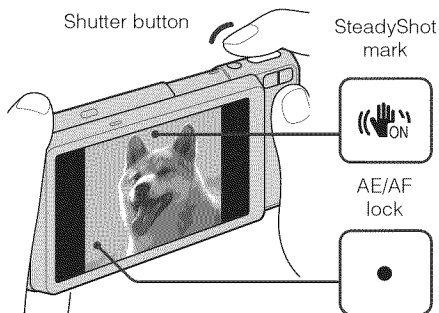

- 4** Press the shutter button fully down.
The image is shot.

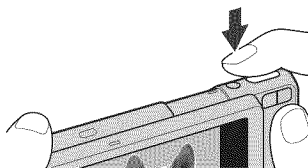

Viewing images

1 Press the (Playback) button.

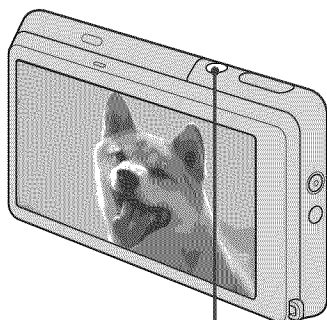

The last image shot is displayed.

- When images on the “Memory Stick Duo” recorded with other cameras cannot be played back on this camera, view the images in [Folder View] (page 36).



 (Playback) button

■ Selecting next/previous image

Touch  (Next)/ (Previous) on the screen.



■ Deleting an image

Touch  (Delete), then touch [OK].



■ Returning to shooting images

Press the shutter button halfway down.

■ Turning off the camera

Close the lens cover.

- You can also turn off the camera by pressing the POWER button.

Storing images

The camera has an approximately 4GB internal memory that can store many images. You can import images from a computer to the camera and view them anytime using the camera.

1 Export images to the camera using “PMB”.

- For details on the computer connection or “PMB”, see page 42.

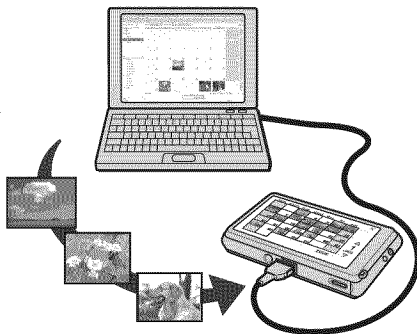

■ Viewing stored images

You can play back images stored in the camera using the Slideshow and Scrapbook functions. You can also organize large numbers of images using the desired View Mode and easily search through them.

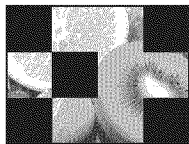

Slideshow (page 34)

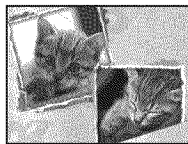

Scrapbook (page 35)

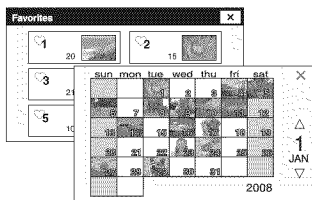

View Mode (page 36)

Uploading images via wireless connection

You can access media services via an access point using wireless LAN and upload images.

Network settings are required before use (page 18).

- 1 Press the WLAN (wireless network) button during the power is on.

The internet browser starts up.
The default setting displays the Sony portal site.

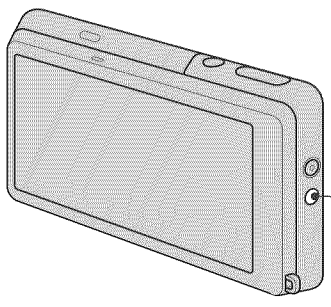

WLAN (Wireless network) button

- 2 Log in to a media service.

- 3 Upload images according to the on-screen instructions.

Notes

- Some media services may not operate correctly.
- You must create an account at the website for each media service in advance.
- The number of images that can be uploaded at once differs depending on the media service.
- It may not be possible to upload some images due to the size of the still image. In addition, the maximum movie size that can be uploaded is 100 MB.
- Operation may become slower if you remove or insert the “Memory Stick Duo” while connected to the network.
- Be sure to use sufficiently charged batteries while connected to the network.

Shutting down the browser

Press the WLAN (wireless network) button, or touch → [OK].

Operation buttons on the internet browser

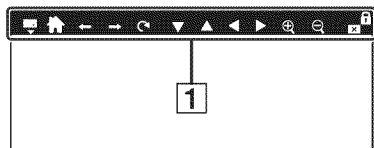

1

Button	Action
	Switches screen display
	Displays Sony portal site
	Next/Previous page
	Update/Cancel loading data
	Scroll key
	Zoom in/zoom out
	Closes the browser

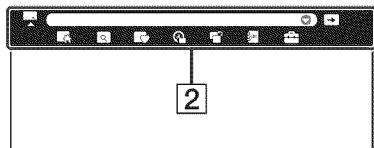

2







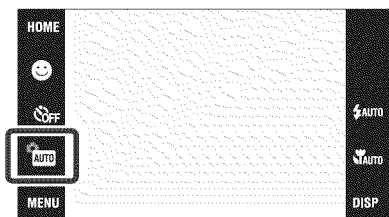

Button	Action
	Switches screen display
	URL display <ul style="list-style-type: none"> You can enter a URL address manually by touching the tab. You can display the URL history by touching

Button	Action
	Jump <ul style="list-style-type: none"> Enter a URL address manually, then touch this button. The screen is moved to the specified website.
	Displays HOME <ul style="list-style-type: none"> You can return to the default Web page.
	Search <ul style="list-style-type: none"> You can search text within the browser.
	Bookmark list
	Displays history
	Switch Tab
	Address Book registration and display
	Web Browser Settings <ul style="list-style-type: none"> Display Mode Settings Text Size Character Encoding Detailed Display Settings Home Page Proxy Cookie Cache Web Browser Information Security





Selecting the desired shooting mode

- 1 Touch  (REC Mode) → desired mode → .



	Shooting mode	Function
	Auto Adjustment	Allows you to shoot still images with the setting adjusted automatically.
	Program Auto	Allows you to shoot with the exposure adjusted automatically (both the shutter speed and the aperture value). You can adjust other settings using the menu.
EASY	Easy Shooting	Allows easy shooting with easy-to-see indicators.
	High Sensitivity	Shoots images without a flash even in low lighting.
	Movie Mode	Shoots movies.
	Landscape	Allows easy shooting of distant scenes by focusing in the distance. Shoots vivid blue sky and flora colors.
	Soft Snap	Shoots images with a softer atmosphere for portraits of people, flowers, etc.
	Twilight Portrait	Shoots sharp images of people in a dark place without losing the nighttime atmosphere.
	Twilight	Shoots night scenes without losing the nighttime atmosphere.
	Scene Selection	Selects the other Scene Selection modes.





Scene Selection modes below 

	Gourmet	Shifts to Macro mode, allowing you to shoot food arrangements in delicious color.
	Beach	Shoots seaside or lakeside scenes with the blueness of the water captured more vividly.
	Snow	Shoots snow scenes in white more clearly.
	Fireworks	Shoots fireworks in all their splendor.
	Hi-Speed Shutter	Shoots moving subjects in bright places.

Note

- The flash does not operate in some Scene Selection modes.

Detecting smiles and shooting automatically (Smile Shutter)

- 1 Touch  (REC Mode) →  (Auto Adjustment) →  or  →  (Smile icon).

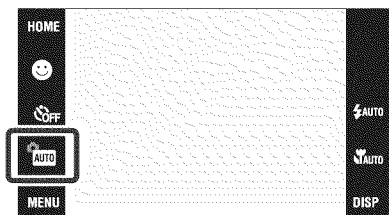

2 Wait detecting a smile.

When the smile level exceeds the point on the indicator, the camera shoots images automatically. When you touch  (Smile icon) again, Smile Shutter ends.

- If you press the shutter button during Smile Shutter, the camera shoots the image in Auto Adjustment, and then returns to Smile Shutter mode.

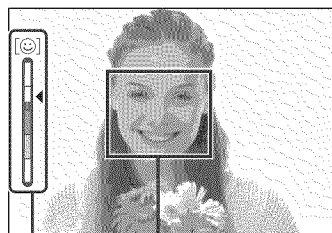

Face Detection frame

Smile Detection Sensitivity indicator





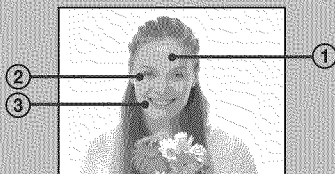

Hints for better capturing of smiles



- ① Do not cover the eyes with the bangs.
- ② Try to orient the face in front of the camera and be as level as possible. The detection rate is higher when the eyes are narrowed.
- ③ Give a clear smile with an open mouth. The smile is easier to detect when the teeth are showing.

Detecting the shooting conditions automatically (Scene Recognition)

The camera automatically detects the shooting conditions, and then takes the shot.

- 1 Touch  (REC Mode) →
 (Auto Adjustment) →
 or .

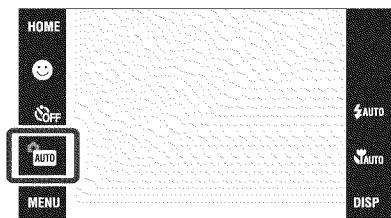







- 2 Touch **MENU** →  (Scene Recognition) → desired mode → **OK**.



 (**Off**): Does not use Scene Recognition.

 (**Auto**): When the camera recognizes the scene, it switches to the optimal settings and shoots the image.

 (**Advanced**): When the camera recognizes the scene, it switches to the optimal settings and shoots the image.

In addition, when the camera recognizes  (Twilight),  (Twilight Portrait),  (Twilight using a tripod),  (Backlight) or  (Backlight Portrait), it shoots another image. When the camera recognizes  (Portrait), Anti Blink operates.

Note

- Scene Recognition does not operate in  (Macro On),  (Close focus enabled) or Burst mode.











When the camera recognizes the scene



Scene Recognition icon

Setting value icon

When the camera recognizes the scene,  (Twilight),  (Twilight Portrait),  (Twilight using a tripod),  (Backlight),  (Backlight Portrait),  (Landscape),  (Macro) or  (Portrait) appears.

When the camera does not recognize the scene, the image is shot as Scene Recognition [Off].

Shooting close-ups (Macro/Close focus)

You can shoot beautiful close-up images of small subjects such as insects or flowers.

- 1 Touch  **AUTO (Macro)** → desired mode → .

 **(Auto):** The camera adjusts the focus automatically from distant subjects to close-up.

Normally, put the camera in this mode.

 **(Macro On):** The camera adjusts the focus with priority on close-up subjects.



Set Macro On when shooting close subjects.

 **(Close focus enabled):** Use this mode to shoot at even closer distances than Macro recording.

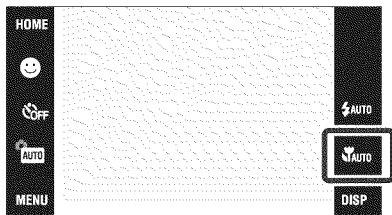

Locked to the W side: Approximately 1 to 20 cm (13/32 to 7 7/8 inches)



Using the self-timer

- 1 Touch  **OFF (Self-Timer)** → desired mode → .

 **(Off):** Not using the self-timer.

 **(Self-Timer 10sec):** Shooting starts after a 10-second delay. Use this setting if you want to include yourself in the image. To cancel, touch .

 **(Self-Timer 2sec):** Shooting starts after a two-second delay. This is to prevent blurring due to unsteadiness when the shutter button is pressed.

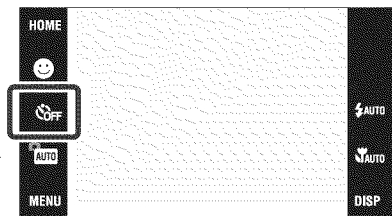

- 2 Press the shutter button.

The self-timer lamp flashes and a beep sounds until the shutter operates.

Selecting a flash mode

- 1 Touch ⚡AUTO (Flash) → desired mode → **OK**.

⚡AUTO (**Flash Auto**): Flashes when there is insufficient light or backlight.

⚡ (**Flash On**): Flash always operates.

⚡SL (**Slow Synchro**): Flash always operates. The shutter speed is slow in a dark place to clearly shoot the background that is out of flash light.

ⓧ (**Flash Off**): Flash does not operate.

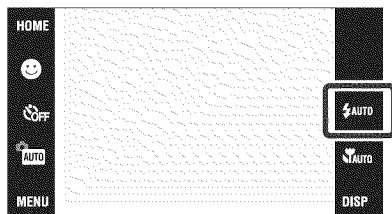

Notes

- You cannot use ⚡ (Flash On) or ⚡SL (Slow Synchro) when Scene Recognition is set to [Auto] or [Advanced].
- Even with flash on, the flash may not operate during burst.



Focusing on a specific point of the frame

Simply touch the point of the frame you wish to focus on to change the focus position.

1 Point the camera at the subject, then touch the point of the frame you want to focus on.

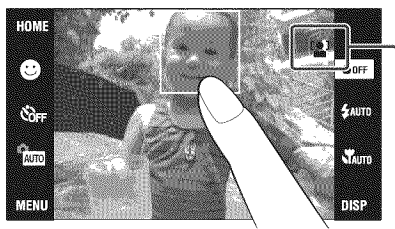
- You can change the focus point as many times as you wish before pressing the shutter button halfway down.
- If you want the camera to choose a focus point automatically, touch  OFF.





: Face detected.
: No face detected.

Focusing on the face of the subject (Face Detection)

The camera detects the face of the subject and focuses on it. You can select which subject takes priority when focusing.

1 Touch **MENU** →  (Face Detection) → desired mode → **OK**.

 **(When touched)**: Detects the face when an area with a face is touched on the screen.

 **(Auto)**: Selects the face the camera is to automatically focus on.

 **(Child Priority)**: Detects and shoots with priority on a child's face.

 **(Adult Priority)**: Detects and shoots with priority on an adult's face.

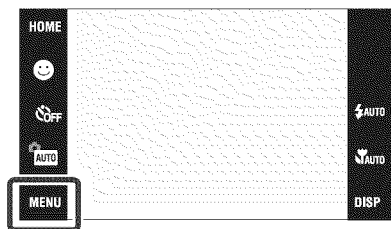

Selecting the image size to match the usage

The image size determines the size of the image file that is recorded when you take a image.

- 1 **MENU** →  (Image Size)
→ desired size → **OK**.

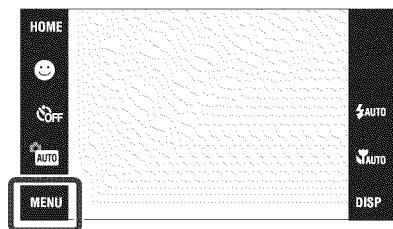













Image size	Usage guidelines	LCD screen
 10M (3648×2736)	For prints up to A3+ size	
 5M (2592×1944)	For prints up to A4 size	
 3M (2048×1536)	For prints up to L/L2 size	
 VGA (640×480)	For e-mail attachments	Images are displayed in 4:3 or 3:2 aspect ratio.
 3:2 (8M) (3648×2432)	3:2 aspect ratio as in photo prints and postcards	
 16:9 (7M) (3648×2056)	For viewing on a high-definition TV	 Images will fill the entire screen.
 16:9 (2M) (1920×1080)		

Movie image size	Frame/Second	Usage guidelines
 640(Fine) (640×480)	Approx. 30	For viewing on a TV (high picture quality)
 640(Standard) (640×480)	Approx. 17	For viewing on a TV (standard picture quality)
 320 (320×240)	Approx. 8	For e-mail attachments

Note

- When you print images shot with 16:9 aspect ratio, both edges may be cut off.

■ Number of images and recording time of movies

The figures in the table below indicate the number of images when [REC Mode] is set to [Normal].

(Units: Images)

Capacity Size	Internal memory	"Memory Stick Duo" formatted with this camera						
	Approx. 4 GB	256 MB	512 MB	1 GB	2 GB	4 GB	8 GB	16 GB
10M	988	56	118	242	493	972	1963	3991
5M	1566	89	188	384	781	1541	3111	6324
3M	2512	144	301	617	1253	2472	4991	10140
VGA	24120	1385	2898	5925	12030	23730	47910	97390
3:2(8M)	996	57	119	244	497	980	1980	4024
16:9(7M)	1048	60	126	257	523	1031	2083	4234
16:9(2M)	4020	230	483	987	2005	3955	7986	16230

The table below shows the approximate maximum recording times. These are the total times for all movie files. Continuous shooting is possible for approximately 10 minutes.

(Units: hour : minute : second)

Capacity Size	Internal memory	"Memory Stick Duo" formatted with this camera						
	Approx. 4 GB	256 MB	512 MB	1 GB	2 GB	4 GB	8 GB	16 GB
640(Fine)	0:50:10	0:02:50	0:06:00	0:12:20	0:25:00	0:49:20	1:39:40	3:22:50
640(Standard)	3:00:50	0:10:20	0:21:40	0:44:20	1:30:10	2:58:00	5:59:20	12:10:20
320	12:03:30	0:41:30	1:25:20	2:57:40	6:01:00	11:52:00	23:57:30	48:41:50

Notes

- The number of still images and the recording time of movies may vary depending on the shooting conditions and the recording media.
- When the number of remaining shootable still images is greater than 9,999, the ">9999" indicator appears.
- When using a "Memory Stick Duo", movies with the size set to [640(Fine)] can be recorded to only a "Memory Stick PRO Duo".
- This camera does not support HD recordings or playbacks for movies.
- When an image shot with other camera is played back on this camera, the image may not appear in the actual image size.
- When many images are recorded in the internal memory, operation may become slightly slower.

Viewing an enlarged image (Playback zoom)

- 1 Press the  (Playback) button to display an image, then touch the area you want to enlarge.

The image is enlarged at twice the size, with the area you touched at the center. When **DISP** (screen display) is set to [Image Only], touch the center of the screen, then touch the area you want to enlarge.

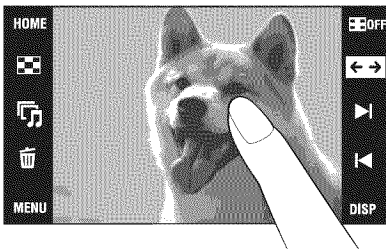

- 2 Adjust the zoom scale and position.

The zoom scale increases each time you touch the screen.

: Adjusts the position.

: Changes the zoom scale.

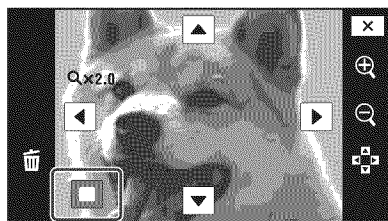

: Turns  on/off.

: Cancels playback zoom.



Shows the displayed area of the whole image



Displaying images full-screen (Wide Zoom)

- 1 Press the  (Playback) button to display the still image, then touch  (Wide Zoom).

• Touch  again to end the wide zoom.



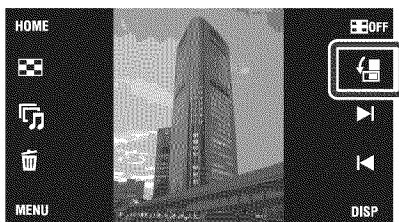

Rotating a vertical orientation image (Temporarily rotated display)

- 1 Press the  (Playback) button to display the still image, then select the vertical orientation images, then touch .
 - Touch  again to end the display.



Viewing still images with music (Slideshow)

- 1 Press the  (Playback) button to display a still image, then touch  (Slideshow).



- 2 Touch [Start].

The slideshow starts.

- To end the slideshow, touch the screen, and then touch [Exit].



Selecting background music

You can transfer a desired music file from your CDs or MP3 files to the camera to play back during slideshow.



To transfer music files, install the "Music Transfer" software (supplied) to your computer (page 43), then follow the steps below.

- ① Touch **HOME** →  (View Images 2) → [Music Tool] → [Download Music].
- ② Make a USB connection between the camera and your computer.
- ③ Start and operate "Music Transfer".







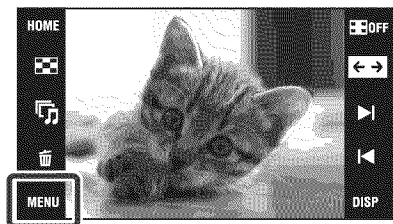

For details on "Music Transfer", see the "Music Transfer" help.

Viewing images with the Scrapbook display

The camera automatically presents images against a background like a homemade photo album.

- 1 Press the  (Playback) button to display a still image, then touch **MENU** →  (Scrapbook) → **OK**.



- 2 Turn the page with / .
- / : Save image in recording media
 - : Background select
 - : Auto playback start
- Touch the screen to stop auto playback.
- : Exit
 - : Return to front cover

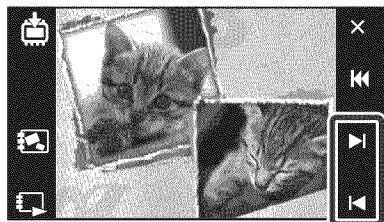



Note

- Scrapbook display is not available when the view mode is set to [Folder View].



To select the save method



[Save This Page]: Save the page you are currently viewing.

[Select pages and save]: Touch /  to display the image, then touch the image to save.

[Save All Pages in Scrapbook]: Saves all images in the scrapbook.

The image size to be saved is 3M.

Searching for an image (Image Index)

- 1 Press the  (Playback) button to display an image, then touch  (Image Index).

- If you touch **DISP**, you can set the number of images displayed in the index screen to 12 or 20 images.

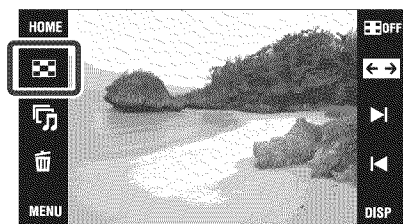



- 2 Touch the / buttons to turn the pages.

- To return to the single-image screen, touch the thumbnail image.





Selecting the display format (View Mode)

Allows you to select the display format for viewing multiple images.

- 1 Press the  (Playback) button to display an image, then touch  (Image Index) →  (View Mode) → desired mode.

-  (Date View): Displays images by the date.

-  (Event View): Analyzes the dates shots and frequency, automatically organizes the images into groups and displays them.

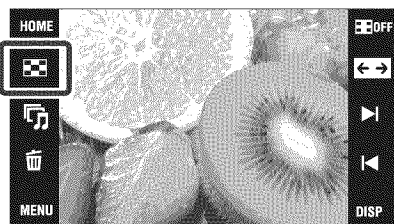

-  (Favorites): Displays images registered as Favorites.

-  (Folder View): Displays and organizes images by folders.



■ Easily locating the images to be displayed

When set to Date View/Event View/Folder View:

Touch  (Date List),  (Event List) or  (Select Folder) to easily locate the desired images.

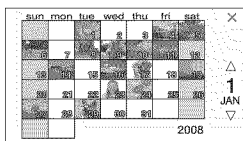

Date List: Displays a list of the images taken on the selected date.

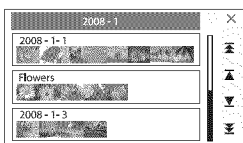

Event List: Displays a list of the images registered to the selected event.

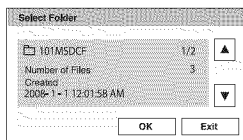

Select Folder: Touch [OK] to display a list of the images contained in the selected folder.

When set to Favorites: You can display images registered to Favorites divided into six groups.

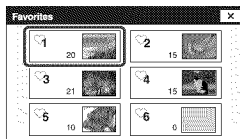

Favorites: Displays a list of the images registered to the selected Favorites number.

Note

- When you cannot play back images recorded with other cameras, view the images in [Folder View].

Viewing images on “BRAVIA”



Operate the DLNA-enabled “BRAVIA” via the home network and set the camera so that images stored in the camera can be viewed.

- 1 **HOME** →
👤 (Communication) →
[Network] → **OK** → 🏠 (Be Viewed) → **OK**.



- 2 Touch [Connect].
If there are multiple access points,
touch [Access pt. to connect to]
to select the access point.

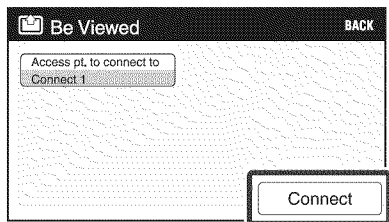

- 3 Select the image to be shared on the network.

- 4 Select the sharing method.

Notes

- You can share only still images.
- You can select up to 100 images at a time.
- To view the images with a DLNA-enabled device, setup and some operations of a playback device are required. For details, see the operating manual of the playback device.
- Be sure to use sufficiently charged batteries while connected to the network.

■ Cancelling one image to be shared

Touch the image during sharing to remove the checkmark.

■ Cancelling all images to be shared

- 38 Touch **MENU** → 🏠 (Remove) → **OK** → [OK] during sharing.

Exiting image sharing

Press the WLAN (wireless network) button, or touch **MENU** → **X** (Exit) → **OK** → [OK].

Sending images to “BRAVIA”



Operate the camera over your home network to send images to a “BRAVIA” that supports a renderer function.

- 1 Touch **HOME** →
[Communication] →
[Network] → **OK** →
[Send and View] →
OK.



- 2 Touch [Search ext. devices].

The camera searches for connectable devices. Detected devices are displayed on the LCD screen.

To connect to the same device as previously, touch [Last Connected Device] → Go to step 4.

- 3 Touch the device you want to connect with.

: Last-connected device

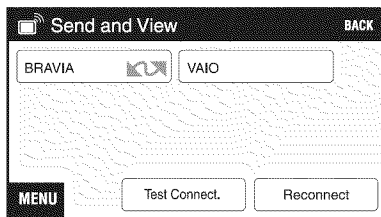

- 4 Select the image you want to send.

- 5 Touch the image to be sent.

To stop sending images

Press the WLAN (wireless network) button, or touch **MENU** → **X** (Exit) → **OK** → [OK].

Notes

- Images can only be played on equipment that supports a renderer function. For details on renderer settings, refer to the “BRAVIA” instruction manual.
- Be sure to use sufficiently charged batteries while connected to the network.



Sending multiple images to the “BRAVIA” all at once

Using slideshow is useful when you want to send multiple images at once.

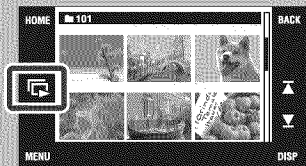

- ① Touch **Slideshow** (Slideshow) in index mode while the connection is made.
- ② Touch the image you want to begin the slideshow from.

Changing the slideshow settings

- 1 Touch **Slideshow** (Slideshow) → **OK** → desired item → desired setting → **OK** in index mode.
- 2 Touch [OK].
Set the following items:
 - Interval Settings (Fast/Normal/Slow)
 - Repeat (On/Off)

Viewing images on a TV

- 1 Connect the camera to the TV with the cable for multi-use terminal (supplied).

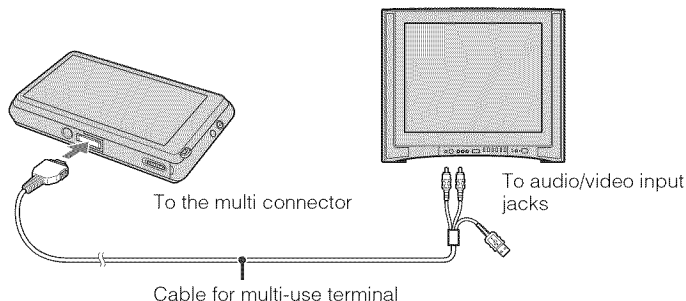

Note

- Output to a TV is not possible while connected to the network.



Viewing images on an HD (High Definition) TV

- You can view images recorded on the camera by connecting the camera to an HD (High Definition) TV with the HD Output Adaptor Cable (not supplied) or Cyber-shot Station (not supplied).
- Set [COMPONENT] to [HD(1080i)] in [Main Settings 2] by selecting  (Settings) on the HOME screen.
- You cannot view movies output in [HD(1080i)] signal format. Set [COMPONENT] to [SD] when viewing movies.

Using the camera with a computer

■ Using “PMB (Picture Motion Browser)”

You can enjoy the recorded still images and movies more than ever by taking advantage of the software, and “PMB” is included on a CD-ROM (supplied).

There are more functions, in addition to those listed below, for enjoying your still images and movies. For details, see “PMB Guide”.

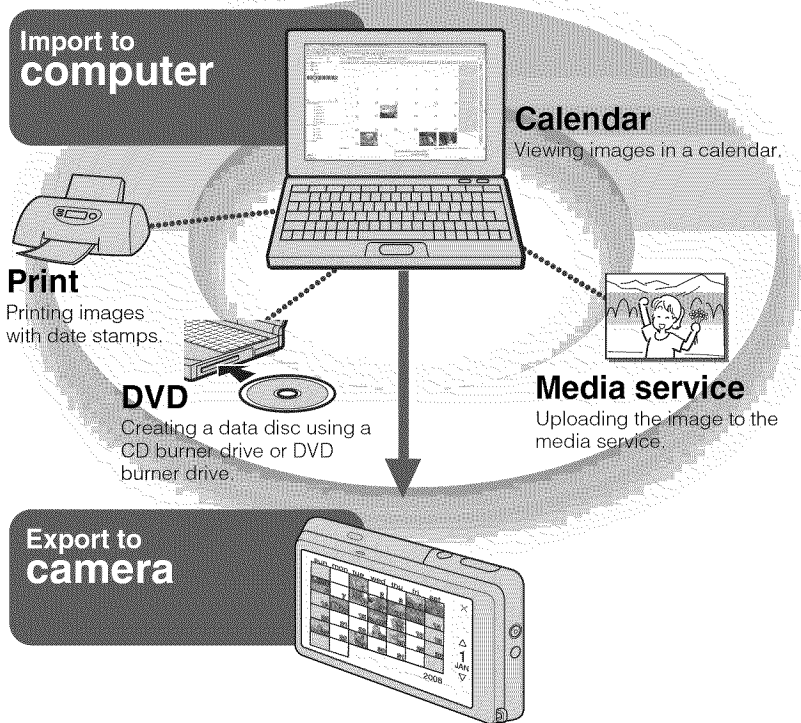

■ Using “PMB Portable”

The camera has a built-in application “PMB Portable” that lets you easily upload images to a media service. You can also upload images with this application from a computer that does not have “PMB” installed. For details, see the “PMB Portable” help.

Note

- “PMB” and “PMB Portable” are not compatible with Macintosh computers.

■ Installing the “PMB” (supplied)

You can install the software (supplied) using the following procedure. When you install “PMB”, “Music Transfer” is also installed.

- Log on as Administrator.

1 Check your computer environment.

Recommended environment for using “PMB” and “Music Transfer”

OS (pre-installed): Microsoft Windows 2000 Professional SP4/Windows XP* SP3/Windows Vista SP1

CPU: Intel Pentium III 500 MHz or faster (Recommended: Intel Pentium III 800 MHz or faster)

Memory: 256 MB or more (Recommended: 512 MB or more)

Hard Disk: Disk space required for installation—approximately 400 MB

Display: Screen resolution: 1,024 × 768 dots or more

* 64-bit editions and Starter (Edition) are not supported.

2 Turn on your computer, and insert the CD-ROM (supplied) into the CD-ROM drive.

The installation menu screen appears.

3 Click [Install].

The “Choose Setup Language” screen appears.

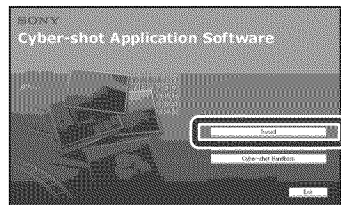

4 Follow the instructions on the screen to complete the installation.



5 Remove the CD-ROM after the installation is complete.

■ Importing images to your computer using “PMB”

1 Insert a fully charged battery pack to the camera, then press the  (Playback) button.

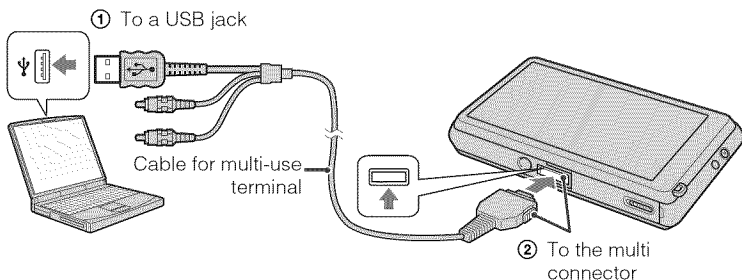
2 Connect the camera to your computer.
“Connecting...” appears on the screen of the camera.



-  is displayed on the screen during the communication session. Do not operate the computer while the indicator is displayed. When the indicator changes to , you can start using the computer again.
-

3 Click the [Import] button.
For details, see the “PMB Guide”.

Notes

- Do not disconnect the cable for multi-use terminal from the camera while the camera is operating or while “Accessing...” appears on the screen of the camera. Doing so may corrupt the data.
- When using a battery with little remaining charge, you may not be able to transfer the data or the data may be corrupted. Using the AC Adaptor (not supplied) and the USB / A/V / DC IN cable for multi-use terminal (not supplied) is recommended.

■ Exporting images to the camera using “PMB”

You can select and export images that have not been exported to the internal memory automatically.

1 Connect the camera to your computer.

If the AutoPlay Wizard appears, close it.

2 Double-click (PMB) on the desktop to start up “PMB”.

3 Click on the top of the screen.

The easy export screen appears.
For details, see the “PMB Guide”.

■ Viewing “PMB Guide”

1 Double-click the (PMB Guide) icon on the desktop.

- To access the “PMB Guide” from the start menu: Click [Start] → [All Programs] → [Sony Picture Utility] → [Help] → [PMB Guide].
-

■ Using “PMB Portable”

1 Connect the camera to your computer.

When you connect the camera and your computer, AutoPlay Wizard [PMBPORTABLE] appears.

- If the desired AutoPlay Wizard does not appear, click [Computer] (in Windows XP/2000, [My Computer]) → [PMBPORTABLE], then double-click “PMB_P.exe”.
-

2 Click “PMB Portable” in AutoPlay Wizard.

The User Agreement screen appears.

3 Follow the instructions on the screen to complete the installation.

“PMB Portable” starts up.

For details, see the “PMB Portable” help.

Note

- Always connect to a network when using “PMB Portable”.

■ Using the camera with your Macintosh computer

You can copy images to your Macintosh computer. “PMB” is not compatible, but you can install “Music Transfer” on your Macintosh computer. When images are exported to the camera, view them in [Folder View].

Recommended computer environment

The following environment is recommended for a computer connected to the camera.

Recommended environment for importing images

OS (pre-installed): Mac OS 9.1/9.2/ Mac OS X (v10.1 to v10.5)

USB jack: Provided as standard

Recommended environment for using “Music Transfer”

OS (pre-installed): Mac OS X (v10.3 to v10.5)

Memory: 64 MB or more (128 MB or more is recommended)

Hard Disk: Disk space required for installation—approximately 250 MB

Changing the screen display

1 Touch **DISP.** → desired mode → **OK**.

 **(Normal):** Displays buttons and icons

 **(Simple):** Displays only buttons

 **(Image Only):** Hides buttons and icons

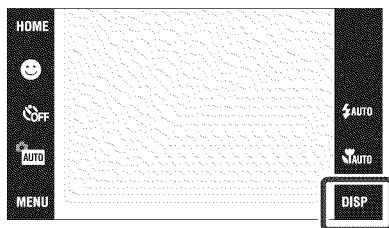

Note

- **DISP** disappears from the screen if [Image Only] playback is selected. To display the buttons, touch the center of the screen. The [Normal] display returns temporarily.



Histogram and brightness settings

The following setting can be accessed by touching **DISP**.

Histogram: A histogram is a graph showing the brightness of an image. The graph display indicates a bright image when skewed to the right side, and a dark image when skewed to the left side.

Brightness: This sets the backlight brightness ([Normal]/[Bright]). When viewing images in bright outside light, reset to [Bright]. However, the battery power may decrease faster under such condition.

Setting the password lock for the internal memory

You can set a password to prevent the playback of images in the internal memory.

- 1 Touch **HOME** →  (Settings) → [Main Settings] → **OK** → [Password Lock] → **OK**.

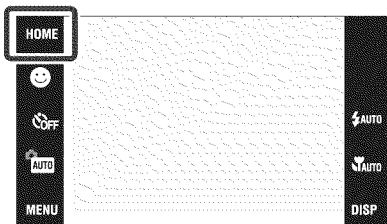

- 2 Input the 4-digit number of your choice → touch [OK].
- 3 Input the same 4-digit number again → touch [OK] → [OK].
- 4 Turn off the camera.

Password Lock is enabled starting from the next playback.

■ Entering the password and playing back images

The password input screen appears → input the password number which you set → touch [OK].

■ Releasing the password lock of the camera

Touch **HOME** →  (Settings) → [Main Settings] → **OK** → [Password Lock] → **OK** → input the password number which you set → [OK] → [OK].

Note

- You cannot set the password for “Memory Stick Duo” images.



What to do when you have forgotten the password

- ① Slide the lens cover.
- ② Press the POWER button to turn off the camera.
- ③ Press  (Playback) button while pressing the W side of the zoom (W/T) button.
- ④ The power is now turned on, and the password release screen appears → touch [OK].
- ⑤ Enter the password release number (page 62) → touch [OK] → [OK].

Using the HOME screen

On the HOME screen, camera operations are organized for convenience into broad categories for selection, such as shooting, viewing and printing images.

Only the available items are displayed on the screen.

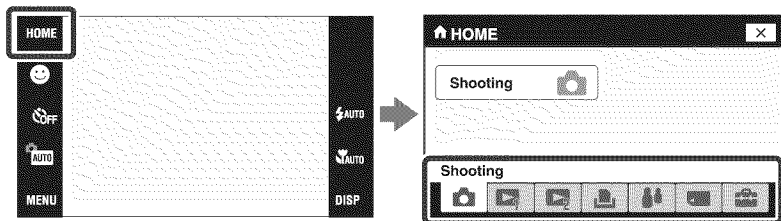

📷 Shooting

Item	Description
Shooting	Records still images or movies.

🖼️ View Images 1

Item	Description
Date View	Displays images by the date.
Event View	Analyzes the dates shots and frequency, automatically organizes the images into groups and displays them.
Favorites	Displays images registered as Favorites.
Folder View	Displays and organizes images by folders.

🖼️ View Images 2

Item	Description
Slideshow	Plays back images in succession along with effects and music.
Music Tool	Download Music: Changes the slideshow music. Format Music: Deletes all slideshow music.
Scrapbook	Attaches a background and displays images like a photo album.

🖨️ Print

Item	Description
Print	Prints still images.

Communication

Item	Description
Network	Upload Images/Browse the Web: Displays the web browser. Be Viewed: Allows you to operate the camera via DLNA-enabled device and view images on the camera. Send and View: Allows you to send images to the DLNA-enabled device and view the images. Network Settings: Sets the network connection settings. (Access Point/Nickname/Network Power Save/Time Zone/Initialize)

Manage Memory

Item	Description
Memory Tool	Format: Formats recording media. Create REC.Folder: Creates a new folder on recording media. Change REC.Folder: Changes the folder used for recording images.

Settings

Item	Description
Main Settings - Main Settings 1	Beep: Selects the beeps produced when you operate the camera. Function Guide: Displays the function guide. Initialize: Restores the camera to its default settings. Calibration: Corrects misalignment of the response positions of the buttons on the touch panel. Demo Mode: Demonstrates the Smile Shutter and Scene Recognition function.
Main Settings - Main Settings 2	USB Connect: Sets the mode used when connecting the camera to a computer or a printer. LUN Settings: Sets the recording media to be displayed on a computer or other device when connecting the camera using a USB connection. COMPONENT: Sets the video signal according to a connected TV terminal. Video Out: Sets the mode according to the video output system to be connected. TV TYPE: Set to the aspect ratio of a TV to be connected. Password Lock: Sets the password for images in the internal memory.

Item	Description	
Shooting Settings - Shooting Settings 1	AF Illuminator: Grid Line: AF Mode: Digital Zoom:	Strobes the fill light when focusing in low light. Displays lines to easily set a subject in a horizontal or vertical position. Selects the auto focus operation mode. Selects the digital zoom method.
Shooting Settings - Shooting Settings 2	Auto Orientation: Auto Review:	Recognizes the orientation change and saves the image in the proper orientation. Displays the image on the screen for approximately two seconds after shooting a still image.
Clock Settings	Sets the date and time.	
Language Setting	Selects the language to be used in the menu items, warnings and messages.	

Using the MENU items

Displays available functions for easy setting when the camera is in shooting or playback mode. Only the available items are displayed on the screen.

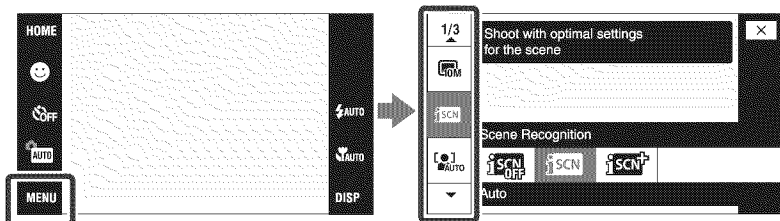

MENU in shooting mode

Item	Description
Image Size	Sets the image size. (10M 10M/5M 5M/3M 3M/LVGA VGA/3:2(8M)/16:9+ 16:9(7M)/16:9 16:9(2M)/FINE 640(Fine)/STD 640(Standard)/320 320)
Scene Recognition	Automatically detects the shooting conditions and then takes the shot. (SCN OFF Off/SCN Auto/SCN+ Advanced)
Face Detection	Selects the priority subject for adjusting the focus when using face detection. (When touched/AUTO Auto/Child Priority/Adult Priority)
Smile Detection Sensitivity	Sets the level of sensitivity to detect smile. (Low/Medium/High)
REC Mode	Selects the continuous shooting method. (Normal/Burst/BRK±0.3EV, BRK±0.7EV, BRK±1.0EV)
EV	Adjusts exposure manually. (-2.0EV to +2.0EV)
Metering Mode	Sets which part of the subject to measure to determine the exposure. (Multi/Center)
Focus	Changes the focus method. (Multi AF/∞ unlimited distance)
White Balance	Adjusts color tones according to the surrounding light conditions. (WB AUTO Auto/Daylight/Cloudy/Fluorescent Light 1, Fluorescent Light 2, Fluorescent Light 3/Incandescent/Flash)
Flash Level	Adjusts the amount of flash light. (Standard/Flash)

Item	Description
Anti Blink	Sets Anti Blink function. (Auto/ Off)
Red Eye Reduction	Sets to reduce the red-eye phenomenon. (Auto/ On/ Off)
DRO	Optimizes the brightness and contrast. (Off/ DRO standard/ DRO plus)
Color Mode	Changes the vividness of the image or adds special effects. (Normal/ Vivid/ Sepia/ B & W)
SteadyShot	Selects the anti-blur mode. (Shooting/ Continuous/ Off)
Shooting Settings	Selects the shooting settings.

MENU in viewing mode

Item	Description
(Date List)	Selects the playback date list.
(Event List)	Selects the event group to be played back.
(Select Folder)	Selects the folder for viewing images.
(View Mode)	Switches the View Modes. (Date View/ Event View/ Favorites/ Folder View)
(Filter by Faces)	Plays back images filtered to meet certain conditions. (OFF/ All people/ Children/ Infants/ Smiles)
(Slideshow)	Plays back images in succession along with effects and music.
(Scrapbook)	Attaches a background and displays images like a photo album.
(Add / Remove Favorites)	Adds images to Favorites or removes images from Favorites. (This Image/ Multiple Images/ Add All in Date Range*/ Remove All in Date Range*) * The displayed text differs according to each View Mode.
(Add / Remove Sharemark)	Registers/cancels registration of images to be uploaded to a media service. (This Image/ Multiple Images/ Add All in Date Range*/ Remove All in Date Range*) * The displayed text differs according to each View Mode.
(Retouch)	Retouches still images. Trimming/ Red Eye Correction/ Unsharp masking/ Soft Focus/ Partial Color/ Fisheye Lens/ Cross Filter/ Radial Blur/ Retro/ Happy Faces)
(Paint)	Paints on a still image and saves as a new image.
(Multi-Purpose Resize)	Changes the image size according to usage. (HDTV/ Blog/E-mail)

Item	Description
(Delete)	Deletes images. (This Image/ Multiple Images/ All in Date Range*) * The displayed text differs according to each View Mode.
(Protect)	Prevents accidental erasure. (This Image/ Multiple Images/ Set All in Date Range*/ Remove All in Date Range*) * The displayed text differs according to each View Mode.
DPOF	Adds a Print order mark to the images you want to print in a "Memory Stick Duo". (This Image/ Multiple Images/ Set All in Date Range*/ Remove All in Date Range*) * The displayed text differs according to each View Mode.
(Print)	Prints images using a PictBridge compliant printer. (This Image/ Multiple Images/ All in Date Range*) * The displayed text differs according to each View Mode.
(Rotate)	Rotates a still image.
(Volume Settings)	Adjusts the volume.

Using functions in Program Auto mode

You can change the Focus, Metering Mode, ISO, and EV settings when [REC Mode] is set to **PGM** (Program Auto).

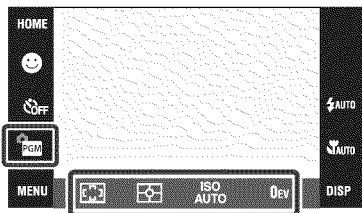

Item	Description
(Focus)	Changes the focus method. (Multi AF/ Center AF/ Spot AF/1.0m/3.0m/7.0m/ ∞ unlimited distance)
(Metering Mode)	Measures the metering area. (Multi/ Center/ Spot)
ISO AUTO (ISO)	Sets the ISO sensitivity. (ISO AUTO/ISO80 to ISO3200)
0EV (EV)	Adjusts the exposure. (-2.0EV to +2.0EV)

Viewing “Cyber-shot Handbook”

“Cyber-shot Handbook”, which explains how to use the camera in detail, is included on the CD-ROM (supplied). Refer to it for in-depth instructions on the many functions of the camera.

■ For Windows users

1 Turn on your computer, and insert the CD-ROM (supplied) into the CD-ROM drive.

2 Click “Cyber-shot Handbook”.

“Cyber-shot Step-up Guide”, which contains information on accessories for the camera, is installed at the same time.

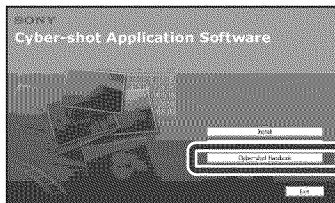

3 Start “Cyber-shot Handbook” from the shortcut on the desktop.

■ For Macintosh users

1 Turn on your computer, and insert the CD-ROM (supplied) into the CD-ROM drive.

2 Select the [Handbook] folder and copy “Handbook.pdf” stored in the [GB] folder to your computer.

3 After copying is complete, double-click “Handbook.pdf”.

List of icons displayed on the screen

Icons are displayed on the screen to indicate the camera status.

You can select the display settings by touching the **DISP** indication on the bottom right of the screen (page 47).

When shooting still images

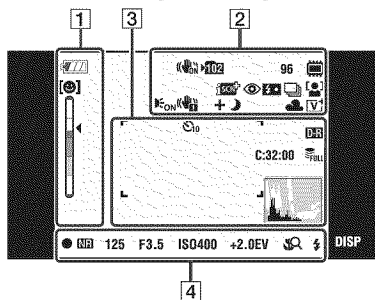

- The icons are limited in **EASY** (Easy Shooting) mode.

When shooting movies

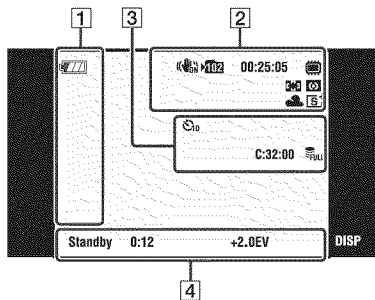

When playing back

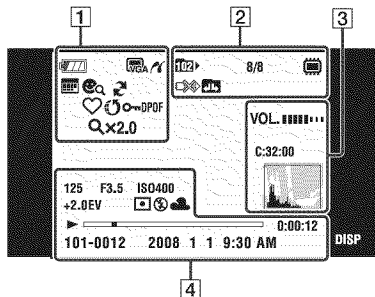

1

Display	Indication
	Battery remaining
	Low battery warning
	Image size
	PictBridge connecting
	Smile Detection Sensitivity indicator
	Zoom scaling
	View Mode
	Filter by Faces
	PMB export
	Favorites
	Sharemark
	Protect
	Print order (DPOF) mark
	Playback zoom

2

Display	Indication
	SteadyShot
	Recording folder

Display	Indication
	Playback folder
96	Number of recordable images
8/8	Image number/Number of images recorded in selected folder
00:25:05	Recordable time (h:m:s)
	Recording/Playback Media ("Memory Stick Duo", internal memory)
	PictBridge connecting
	Changing folder
	Scene Recognition
	Red-eye reduction
	Flash level
	Flash charging
	Recording mode
	Face Detection
	Metering Mode
	Focus
	AF illuminator
	Vibration warning
	Touch AF indicator
	White balance
	Color mode

3

Display	Indication
	AF range finder frame

Display	Indication
	Self-timer
	DRO
	Management file full
	Volume
C:32:00	Self-diagnosis display
	Histogram <ul style="list-style-type: none"> appears when histogram display is disabled.

4

Display	Indication
	AE/AF lock
	NR slow shutter
125	Shutter speed
F3.5	Aperture value
ISO400	ISO number
+2.0EV	Exposure Value
	Metering mode
	Flash
	White balance
	Macro/Close focus <ul style="list-style-type: none"> Displayed when [Display Setup] is set to [Image Only].
	Flash mode <ul style="list-style-type: none"> Displayed when [Display Setup] is set to [Image Only].
REC Standby	Recording a movie/Standby a movie
0:12	Recording time (m:s)
	Playback
	Playback bar
0:00:12	Counter
101-0012	Folder-file number
2008 1 1 9:30 AM	Recorded date/time of the playback image

Troubleshooting

If you experience trouble with the camera, try the following solutions.

- 1 Check the items below, and refer to “Cyber-shot Handbook” (PDF).**
If a code such as “C/E:□□:□□” appears on the screen, refer to “Cyber-shot Handbook”.

- 2 Remove the battery pack, wait for about one minute, re-insert the battery pack, then turn on the power.**

- 3 Initialize the settings (page 50).**

- 4 Consult your Sony dealer or local authorized Sony service facility.**

On repairing cameras with internal memory or Music files function included, data in the camera may be checked on minimum necessity to verify and improve the malfunction symptoms. Sony will not copy or save any of those data.

Battery pack and power

Cannot insert the battery pack.

- Insert the battery pack correctly to push the battery eject lever (page 15).

Cannot turn on the camera.

- After inserting the battery pack into the camera, it may take a few moments for the camera to power up.
- Insert the battery pack correctly (page 15).
- The battery pack is discharged. Insert a charged battery pack (page 13).
- The battery pack is dead. Replace it with a new one.
- Use a recommended battery pack.

The power turns off suddenly.

- If you do not operate the camera for about three minutes while the power is on, the camera turns off automatically to prevent wearing down the battery pack. Turn on the camera again (page 17).
- The battery pack is dead. Replace it with a new one.

The remaining charge indicator is incorrect.



- The battery charge is quickly used up in the following cases:
 - When you use the camera in an extremely hot or cold location.
 - When you use the flash and zoom frequently.
 - When you repeatedly turn the power on and off.
 - When [Brightness] of the **DISP** (screen display) is set to [Bright].
- A discrepancy arose between the remaining charge indicator and the actual remaining battery charge. Fully discharge the battery pack once, then charge it to correct the indication.
- The battery pack is discharged. Insert the charged battery pack (page 13).
- The battery pack is dead. Replace it with a new one.

Cannot charge the battery pack while inside the camera.

- You cannot charge the battery pack using the AC Adaptor (not supplied). Use the battery charger (supplied) to charge the battery.

Shooting still images/movies

Cannot record images.

- Check the free capacity of the internal memory or “Memory Stick Duo” (page 32). If it is full, do one of the following:
 - Delete unnecessary images.
 - Change the “Memory Stick Duo”.
- You cannot record images while charging the flash.
- When shooting a still image, set the shooting mode other than  (Movie).
- Set the shooting mode to  (Movie) when shooting movies.
- The image size is set to [640(Fine)] when recording movies. Do one of the following:
 - Set the image size to other than [640(Fine)].
 - Record images in the internal memory or on a “Memory Stick PRO Duo.”

Vertical streaks appear when you are shooting a very bright subject.

- The smear phenomenon is occurring and white, black, red, purple or other streaks appear on the image. This phenomenon is not a malfunction.

Viewing images

Cannot play back images.

- Press  (Playback) button (page 21).
- The folder/file name has been changed on your computer.
- No guarantees are made for playing back, on this camera, files containing images which were processed on a computer or images which were shot using other cameras.
- The camera is in USB mode. Delete the USB connection.
- You may not be able to play back some images stored on the “Memory Stick Duo” shot using other cameras. Play such images in Folder View (page 36).
- This is caused by copying images on your computer to the “Memory Stick Duo” without using the “PMB”. Play such images in Folder View (page 36).

Wireless network

Cannot establish a connection with the Wireless LAN access point.

- Check to make sure the power of the Wireless LAN access point is on.
- The communication range may be shortened by the surrounding conditions, such as various obstacles, radio wave traffic, and the wall material between this camera and the Wireless LAN access point. Change the location of the camera or move the camera closer to the access point.
- Check whether an encryption key (WEP/WPA) or other special settings (Fixed IP address, proxy settings, etc.) are needed to connect to the access point.
- When the access point is set so that the SSID is hidden, the SSID may not be displayed on the network list. Check the SSID of the access point with an administrator and make settings manually. Or cancel the setting on the access point.
- You may be unable to use the internet at public Wireless LAN access points unless you use the Web or another method to enter your login ID, password, or other identifying information. Check with the wireless network service that you are connecting to.
- Microwave ovens or Bluetooth-enabled devices use the 2.4 GHz wavelength and could hinder the communication. If such devices are in the vicinity, move the camera away from those devices or shut those devices down.

Cannot enter the encryption key.

- For details on the verification method used for the encryption key (WEP key or WPA key), see the operation manual for the access point or the information listed on the bottom panel of the device.
- The number of characters and numbers that can be input differs depending on the encryption type.

The MAC address of this camera is unknown.

- To check the MAC address, enter an invalid SSID and test the connection to force a connection failure. The MAC address of this camera will be displayed after the connection test.

It takes too much time to transfer an image.

- The communication range may be shortened by the surrounding conditions, such as various obstacles, radio wave traffic, and the wall material between the devices or between this camera and the Wireless LAN access point. Change the location of the devices, put the devices closer together, or move the camera closer to the access point.
- You may be getting a crossed connection with another Wireless LAN access point. Set the wireless channel at the Wireless LAN access point. For further information, refer to the operating manual of the Wireless LAN access point.
- Microwave ovens or Bluetooth-enabled devices use the 2.4 GHz wavelength and could hinder the communication. If such devices are in the vicinity, move the camera away from those devices or shut those devices down.

Cannot connect to a hotspot (public Wireless LAN access point) service.

- Check with the hotspot service provider that you have contracted with.

Precautions

Do not use/store the camera in the following places

- In an extremely hot, cold or humid place
In places such as in a car parked in the sun, the camera body may become deformed and this may cause a malfunction.
- Under direct sunlight or near a heater
The camera body may become discolored or deformed, and this may cause a malfunction.
- In a location subject to rocking vibration
- Near strong magnetic place
- In sandy or dusty places
Be careful not to let sand or dust get into the camera. This may cause the camera to malfunction, and in some cases this malfunction cannot be repaired.

On carrying

Do not sit down in a chair or other place with the camera in the back pocket of your trousers or skirt, as this may cause malfunction or damage the camera.

On cleaning

Cleaning the LCD screen

Wipe the screen surface with an LCD cleaning kit (not supplied) to remove fingerprints, dust, etc.

Cleaning the lens

Wipe the lens with a soft cloth to remove fingerprints, dust, etc.

Cleaning the camera surface

Clean the camera surface with a soft cloth slightly moistened with water, then wipe the surface with a dry cloth. To prevent damage to the finish or casing:

- Do not expose the camera to chemical products such as thinner, benzine, alcohol, disposable cloths, insect repellent, sunscreen or insecticide.
- Do not touch the camera with any of the above on your hand.
- Do not leave the camera in contact with rubber or vinyl for a long time.

On operating temperatures

Your camera is designed for use under the temperatures between 0°C and 40°C (32°F and 104°F). Shooting in extremely cold or hot places that exceed this range is not recommended.

On moisture condensation

If the camera is brought directly from a cold to a warm location, moisture may condense inside or outside the camera. This moisture condensation may cause a malfunction of the camera.

If moisture condensation occurs

Turn off the camera and wait about an hour for the moisture to evaporate. Note that if you attempt to shoot with moisture remaining inside the lens, you will be unable to record clear images.

On the internal rechargeable backup battery

This camera has an internal rechargeable battery for maintaining the date and time and other settings regardless of whether the power is on or off.

This rechargeable battery is continually charged as long as you are using the camera. However, if you use the camera for only short periods, it discharges gradually, and if you do not use the camera at all for about one month it becomes completely discharged. In this case, be sure to charge this rechargeable battery before using the camera.

However, even if this rechargeable battery is not charged, you can still use the camera, but the date and time will not be indicated.

Charging method of the internal rechargeable backup battery

Insert charged battery pack in the camera, and then leave the camera for 24 hours or more with the power off.

Precaution when disposing of the camera

Formatting the camera does not completely delete all of the data in the internal memory. Therefore, when disposing of the camera, physically destroying the camera is recommended.

Specifications

Camera

[System]

Image device: 7.7 mm (1/2.3 type) color CCD,
Primary color filter

Total pixel number of camera:
Approx. 10.3 Megapixels

Effective pixel number of camera:
Approx. 10.1 Megapixels

Lens: Carl Zeiss Vario-Tessar 4x zoom lens
f = 6.18 – 24.7 mm (35 – 140 mm (35 mm
film equivalent))
F3.5 (W) – F4.6 (T)

Exposure control: Automatic exposure, Scene
Selection (10 modes)

White balance: Automatic, Daylight, Cloudy,
Fluorescent 1,2,3, Incandescent, Flash

File format (DCF compliant):
Still images: Exif Ver. 2.21 JPEG compliant,
DPOF compatible
Movies: MPEG1 compliant (Monaural)

Recording media: Internal Memory
(approx. 4 GB*), "Memory Stick Duo"

* When measuring media capacity, 1GB equals
1 billion bytes, a portion of which is used for
system management and/or application files.
The capacity that a user can use is
approximately 3.71GB.

Flash: Flash range (ISO sensitivity
(Recommended exposure Index) set to Auto):
Approx. 0.08 to 4.3 m (3 1/4 inches to
14 feet 1 3/8 inches) (W)/
approx. 0.5 to 3.4 m (1 feet 7 3/4 inches to
11 feet 1 7/8 inches) (T)

[Input and Output connectors]

Multi-use terminal Type1a (AV-out(SD/HD
Component)/USB/DC-in):
Video output
Audio output (Monaural)
USB communication

USB communication: Hi-Speed USB (USB 2.0
compliant)

[LCD screen]

LCD panel: Wide (16:9), 8.8 cm (3.5 type) TFT
drive

Total number of dots: 921 600 (1920 × 480) dots

[Power, general]

Power: Rechargeable battery pack NP-BD1, 3.6 V
NP-FD1 (not supplied), 3.6 V
AC-LSSK AC Adaptor (not supplied), 4.2 V

Power consumption (during shooting): 1.2 W
Operating temperature: 0 to 40°C (32 to 104°F)
Storage temperature: –20 to +60°C (–4 to +140°F)

Dimensions

During shooting: 123.7 × 62.3 × 19.4 mm
(4 7/8 × 2 1/2 × 25/32 inches) (W/H/D,
excluding protrusions)

During playback: 101.7 × 62.3 × 19.4 mm
(4 1/8 × 2 1/2 × 25/32 inches) (W/H/D,
excluding protrusions)

Mass (including NP-BD1 battery pack and strap
etc.): Approx. 198 g (7.0 oz)

Microphone: Monaural

Speaker: Monaural

Exif Print: Compatible

PRINT Image Matching III: Compatible

PictBridge: Compatible

[Password]

Release number: 7669

[Wireless LAN]

Standards: IEEE802.11b/g

Channel: 1 to 11 (USA, Canada, Taiwan)
1 to 13 (EU, China, Hong Kong, South Korea)

BC-CSD battery charger

Power requirements: AC 100 V to 240 V,
50/60 Hz, 2.2 W

Output voltage: DC 4.2 V, 0.33 A

Operating temperature: 0 to 40°C (32 to 104°F)

Storage temperature: –20 to +60°C (–4 to +140°F)

Dimensions: Approx. 62 × 24 × 91 mm (2 1/2 ×
31/32 × 3 5/8 inches) (W/H/D)

Mass: Approx. 75 g (2.7 oz)

Rechargeable battery pack NP-BD1

Used battery: Lithium-ion battery

Maximum voltage: DC 4.2 V

Nominal voltage: DC 3.6 V

Capacity: 2.4 Wh (680 mAh)

Design and specifications are subject to
change without notice.

Trademarks

- The following marks are trademarks of Sony Corporation.
Cyber-shot, “Cyber-shot”, “Memory Stick”,  “Memory Stick PRO”, **MEMORY STICK PRO**, “Memory Stick Duo”, **MEMORY STICK DUO**, “Memory Stick PRO Duo”, **MEMORY STICK PRO DUO**, “Memory Stick PRO-HG Duo”, **MEMORY STICK PRO-HG DUO**, “Memory Stick Micro”, “MagicGate”, **MAGIC GATE**, “PhotoTV HD”, “Info LITHIUM”, “BRAVIA”
 - Microsoft, Windows, DirectX and Windows Vista are either registered trademarks or trademarks of Microsoft Corporation in the United States and/or other countries.
 - Macintosh and Mac OS are trademarks or registered trademarks of Apple Inc.
 - Intel, MMX, and Pentium are trademarks or registered trademarks of Intel Corporation.
 - DLNA and DLNA CERTIFIED are trademarks and/or service marks of Digital Living Network Alliance.
 - Adobe and Reader are either trademarks or registered trademarks of Adobe Systems Incorporated in the United States and/or other countries.
 - This product contains Adobe® Flash® Player under license from Adobe Systems Incorporated. Copyright© 1995-2007 Adobe Macromedia Software LLC. All rights reserved.
 Adobe and Flash are either registered trademarks or trademarks of Adobe Systems Incorporated in the United States and/or other countries.
 - This product contains NetFront Browser, NetFront Living Connect, AVE-TCP of ACCESS CO., LTD.
 ACCESS, ACCESS logo, NetFront and AVE are trademarks or registered trademarks of ACCESS CO., LTD. in the United States, Japan and other countries.
 © 2008 ACCESS CO., LTD. All rights reserved.
 This software is based in part on the work of the Independent JPEG Group.
- ACCESS™ NetFront™**
- AdvancedWnn© Copyright OMRON SOFTWARE Co., Ltd. 2003-2006 All Rights Reserved.
 - Contains iType™ from Monotype Imaging, Inc. iType is a trademark of Monotype Imaging Inc. and registered in the U.S. Patent and Trademarks Office and which may be registered in certain jurisdictions.
 - In addition, system and product names used in this manual are, in general, trademarks or registered trademarks of their respective developers or manufacturers. However, the ™ or ® marks are not used in all cases in this manual.

Additional information on this product and answers to frequently asked questions can be found at our Customer Support Website.

<http://www.sony.net/>



Printed on 70% or more recycled paper using VOC (Volatile Organic Compound)-free vegetable oil based ink.

Printed in Japan



4105996210