

Operator's Manual

CRAFTSMAN®

175LB PROFESSIONAL SPREADER

Model No. 71-24594

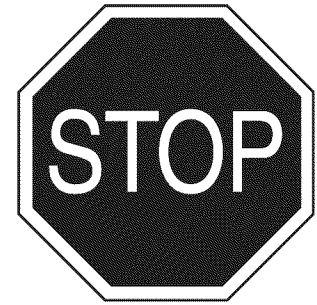

DO NOT RETURN TO STORE
For Missing Parts or Assembly
Questions Call 1-866-576-8388



CAUTION:

Before using this product, read this manual and follow all Safety Rules and Operating Instructions.

- Safety
- Assembly
- Operation
- Maintenance
- Parts

Sears, Roebuck and Co., Hoffman Estates, IL 60179 U.S.A.
www.sears.com/craftsman

TABLE OF CONTENTS

WARRANTY.....2	MAINTENANCE.....9
SAFETY.....2	SERVICE AND ADJUSTMENTS.....9
CARTON CONTENTS.....3	STORAGE.....9
FULL SIZE HARDWARE CHART.....3	REPAIR PARTS ILLUSTRATION.....10
ASSEMBLY.....5	REPAIR PARTS LIST.....11
ACCESSORIES AND ATTACHMENTS.....8	PARTS ORDERING/SERVICE.....BACK PAGE

WARRANTY

CRAFTSMAN PROFESSIONAL FULL WARRANTY

When operated and maintained according to all supplied instructions, if this Craftsman Professional product fails due to a defect in material or workmanship within two years from the date of purchase, return it to any Sears store or other Craftsman Professional outlet in the United States for free replacement.

This warranty applies for only 90 days from the date of purchase if this product is ever used for commercial or rental purposes.

This warranty does not include items considered to expendable parts that can wear out from normal use within the warranty period.

This warranty gives you specific legal rights, and you may also have other rights which vary from state to state.

Sears, Roebuck and Co., D817WA, Hoffman Estates, IL 60179

DO NOT RETURN TO STORE for Missing Parts or Assembly Questions

Call 1-866-576-8388 Attachment Hotline

<p>The model number and serial numbers will be found on a decal attached to the 175lb Professional Spreader.</p> <p>You should record both the serial number and the date of purchase and keep in a safe place for future reference.</p>	<table style="width: 100%; border-collapse: collapse;"> <tr> <td style="width: 60%;">MODEL NUMBER:</td> <td style="width: 40%;">71-24594</td> </tr> <tr> <td>SERIAL NUMBER:</td> <td>_____</td> </tr> <tr> <td>DATE OF PURCHASE:</td> <td>_____</td> </tr> </table>	MODEL NUMBER:	71-24594	SERIAL NUMBER:	_____	DATE OF PURCHASE:	_____
MODEL NUMBER:	71-24594						
SERIAL NUMBER:	_____						
DATE OF PURCHASE:	_____						



SAFETY



Any power equipment can cause injury if operated improperly or if the user does not understand how to operate the equipment. Exercise caution at all times when operating equipment.

- Read the towing vehicle owners manual and towing vehicle safety rules. Know how to operate your tractor before using the broadcast spreader attachment.
- Read the chemical label instructions and cautions for handling and applying the chemicals purchased for spreading.
- Wear eye and hand protection when handling and when applying lawn or garden chemicals.
- Never operate tractor and spreader attachment without wearing substantial footwear, and do not allow anyone to ride or sit on spreader attachment frame.
- Never allow children to operate the tractor or spreader attachment, and do not allow adults to operate without proper instructions.
- Always begin with the transmission in first (low) gear and with the engine at low speed, and gradually increase speed as conditions permit.
- When towing broadcast spreader do not drive too close to a creek or ditch and be alert for holes and other hazards which could cause you to loose control of the broadcast spreader and tractor.
- Before operating vehicle on any grade (hill) refer to the safety rules in the vehicle owner's manual concerning safe operation on slopes. **Stay off steep slopes!**
- Follow maintenance and lubrication instructions as outlined in this manual.



LOOK FOR THIS SYMBOL TO POINT OUT IMPORTANT SAFETY PRECAUTIONS. IT MEANS — ATTENTION! BECOME ALERT! YOUR SAFETY IS INVOLVED.

CARTON CONTENTS

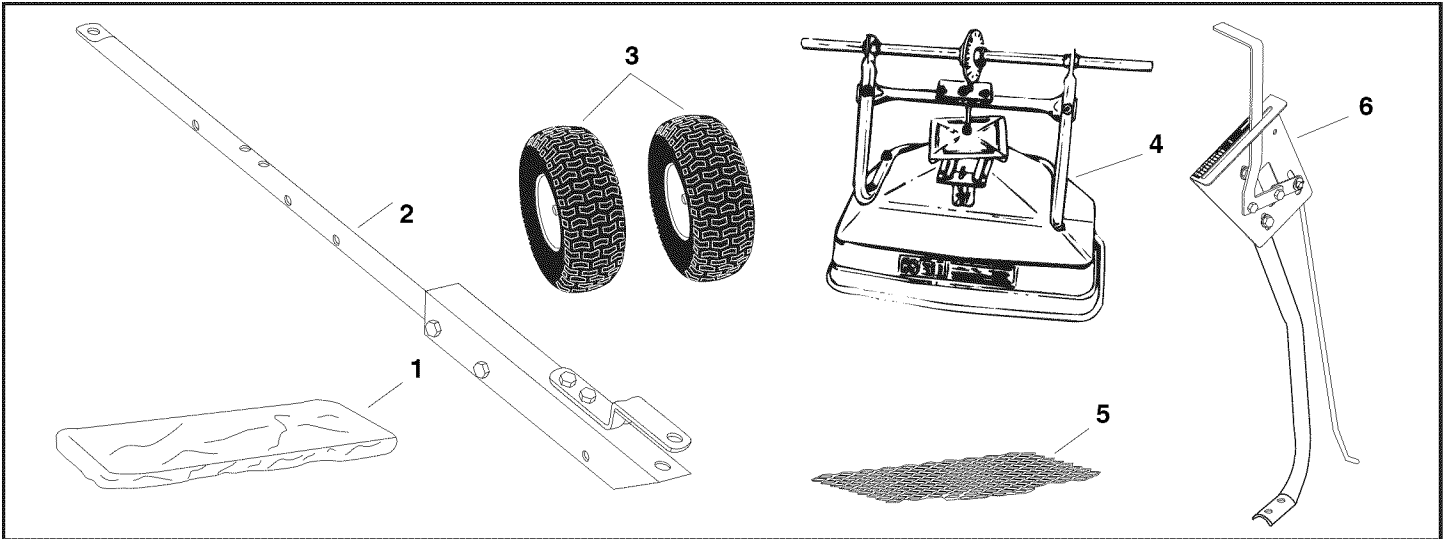

REF	DESCRIPTION	REF	DESCRIPTION
1	Hopper Cover	4	Hopper Assembly
2	Hitch Tube	5	Screen
3	Wheels (2)	6	Flow Control Mounting Tube

FULL SIZE HARDWARE CHART

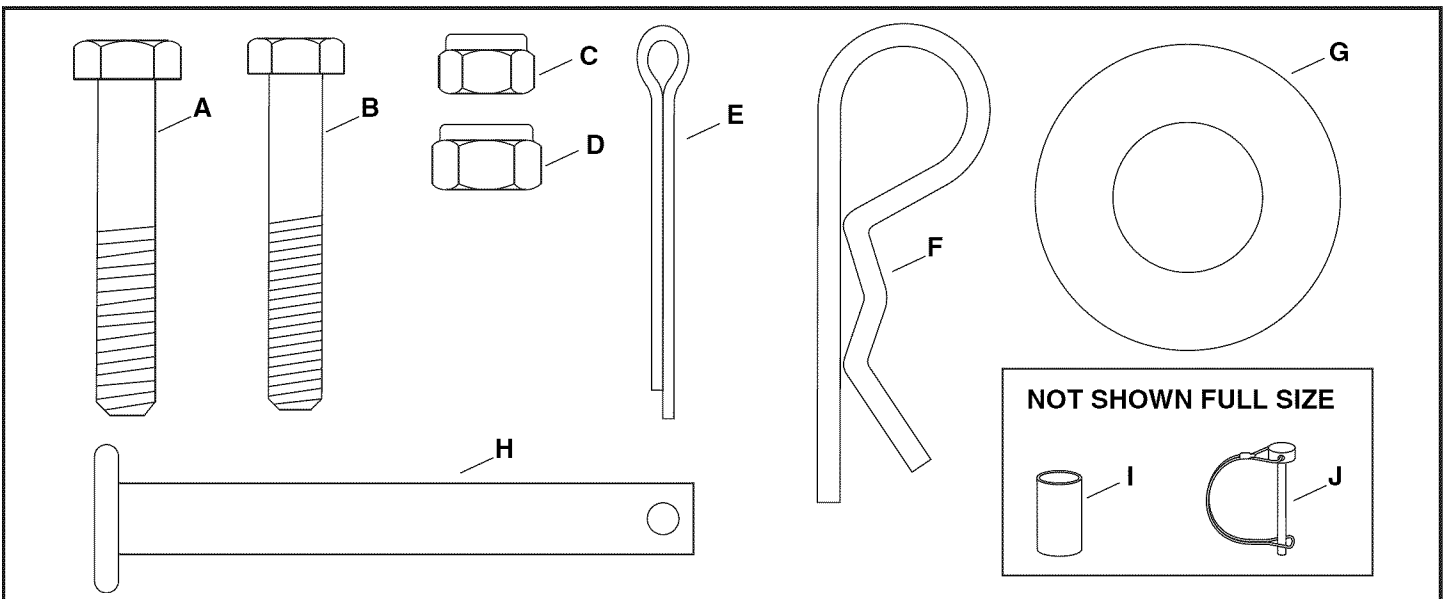

KEY	QTY	DESCRIPTION	KEY	QTY	DESCRIPTION
A	2	Hex Bolt, 5/16" x 1-3/4"	F	1	Hair Cotter Pin, 1/8"
B	2	Hex Bolt, 1/4" x 1-3/4"	G	4	Flat Washers 3/4"
C	2	Nylock Hex Nut, 1/4"	H	1	Hitch Pin
D	2	Nylock Hex Nut, 5/16"	I	2	Spacers
E	2	Cotter Pin, 1/8 x 1-1/2"	J	1	Drive Pin

ASSEMBLY

TOOLS REQUIRED FOR ASSEMBLY

- (1) Pliers
- (2) 7/16" Wrenches
- (2) 1/2" Wrenches
- (2) 9/16" Wrenches

REMOVAL OF PARTS FROM CARTON

Remove all parts and hardware packages from the carton. Lay out all parts and hardware and identify using the illustrations on page 3.

STEP 1: (SEE FIGURE 1)

1. Turn the spreader upside down.
2. Remove lock nut from middle bolt in crossover tube and shaft support plate. Leave the bolt in place.
3. Assemble hitch tube onto middle bolt and secure it with the same lock nut you removed. **DO NOT TIGHTEN YET.**

IMPORTANT: The hitch tube must attach to the side of the crossover tube opposite the shaft support plate.

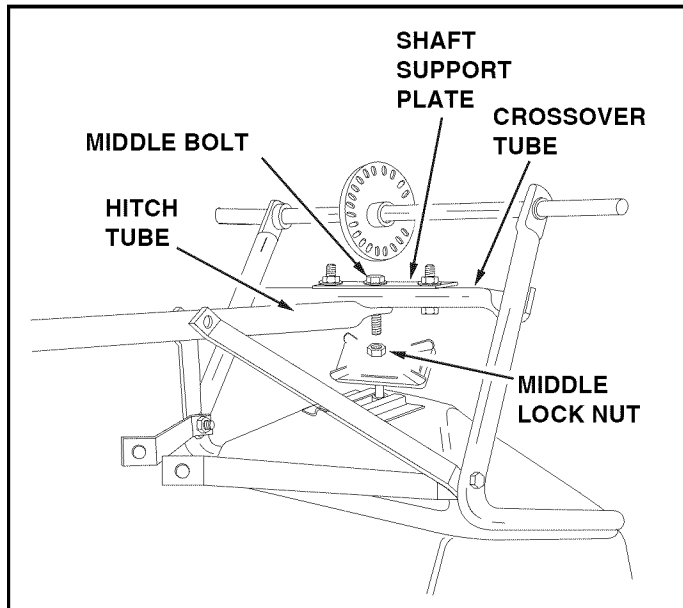

FIGURE 1

STEP 2: (SEE FIGURE 2)

4. Assemble the two **OUTER** hitch braces to the hitch tube using a 1/4" x 1-3/4" (B) hex bolt and a 1/4" nylock hex nut (C). **DO NOT TIGHTEN YET.** Do not assemble the inner hitch braces at this time.

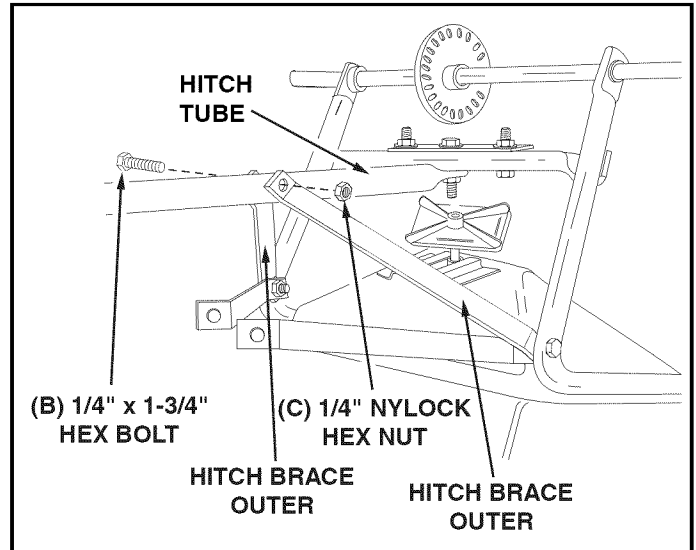

FIGURE 2

STEP 3: (SEE FIGURE 3)

5. Assemble a spacer (I), a 3/4" flat washer (G), a wheel (air valve facing out) and another 3/4" flat washer (G) onto the end of the axle that has only the **small hole**.
6. Install a 1/8" x 1-1/2" cotter pin (E) into the hole in the axle.

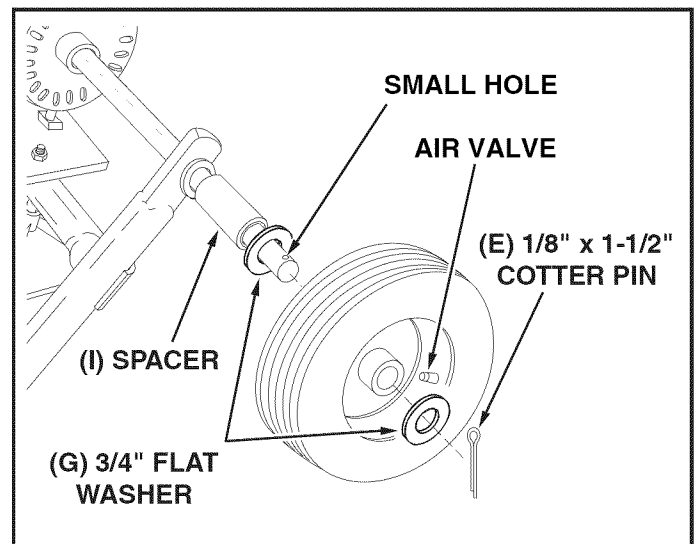

FIGURE 3

STEP 4: (SEE FIGURE 4)

10. Assemble a spacer (I), a 3/4" flat washer (G), a wheel (air valve facing out) and another 3/4" flat washer (G) onto the end of the axle that has both the **large and small holes**.
11. Install a 1/8" x 1-1/2" cotter pin (E) into the small hole in the end of the axle.
12. Open the bail on the drive pin (J) and install it through the wheel and the large hole in the axle. Close the bail to lock the pin in place.

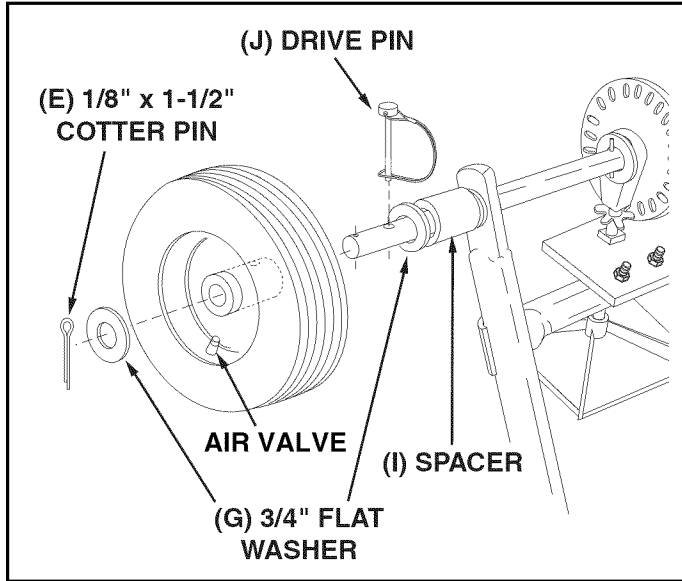

FIGURE 4

STEP 5: (SEE FIGURE 5)

9. Hook the double bent end of the flow control rod through the hole in the slide gate bracket located near the bottom of the hopper.

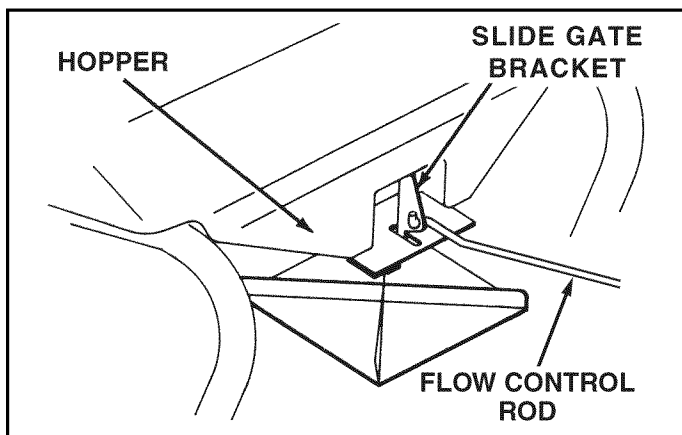

FIGURE 5

STEP 6: (SEE FIGURE 6)

7. Turn the spreader upright on its wheels.
8. Assemble the flow control mounting tube to the hitch tube using two 5/16" x 1-3/4" hex bolts (A) and 5/16" nylock hex nuts (D). **DO NOT TIGHTEN YET.**

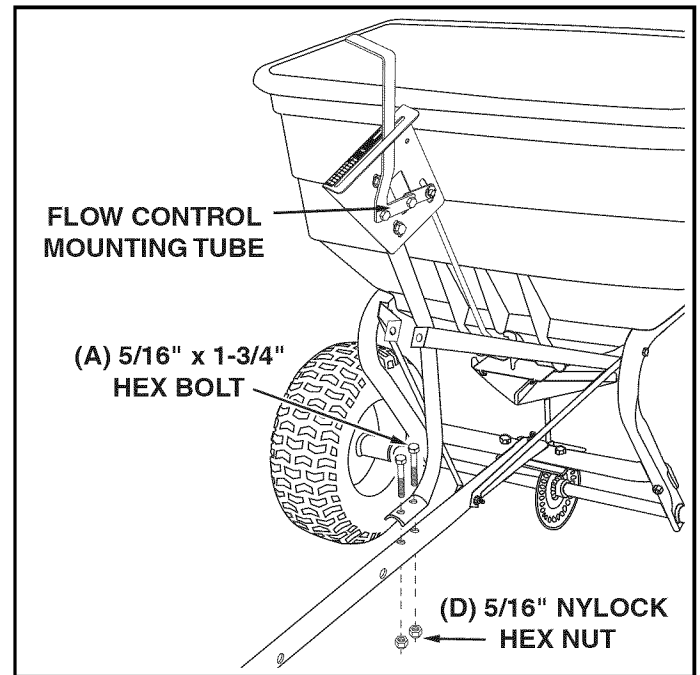

FIGURE 6

STEP 7: (SEE FIGURE 7)

13. Assemble the two **INNER** hitch braces to flow control mounting tube using a 1/4" x 1-3/4" hex bolt (B) and a 1/4" nylock hex nut (C). **DO NOT TIGHTEN YET.**
14. **TIGHTEN** all nuts and bolts assembled up to this point. **Do not collapse the tubes when tightening.**

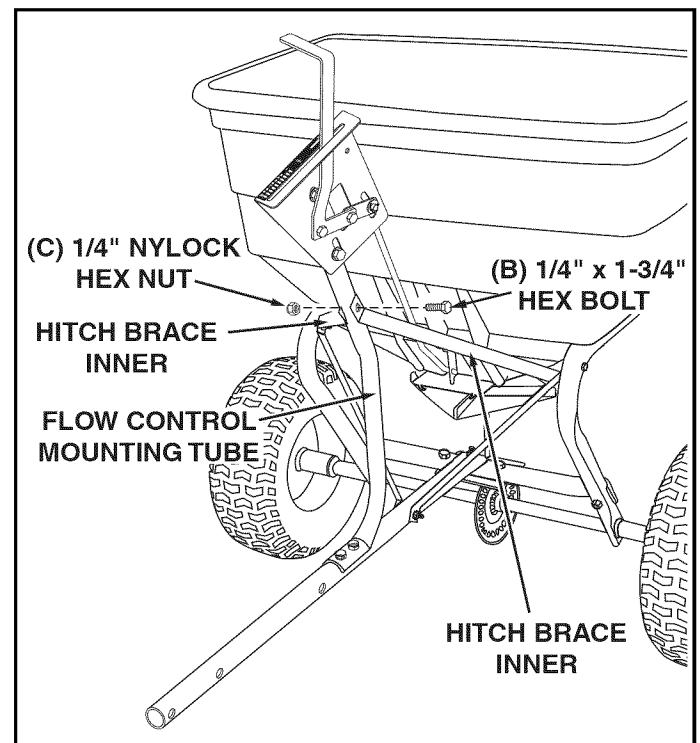

FIGURE 7

STEP 8: (SEE FIGURE 8)

- Push on flow control arm until it locks in "OFF" position.
- Slide flow control mounting bracket along tube until closure plate in bottom of hopper just closes.
- Snug the 5/16" nylock hex nuts just enough to hold flow control mounting bracket in place.
- Set adjustable stop at "5". Pull flow control arm against stop. Verify that closure plate has opened about half way.
- If closure plate does not open half way, adjust position of flow control mounting bracket until closure plate will open about half way at "5" and will still close when arm is locked in "OFF" position. Tighten the 5/16" nylock hex nuts.

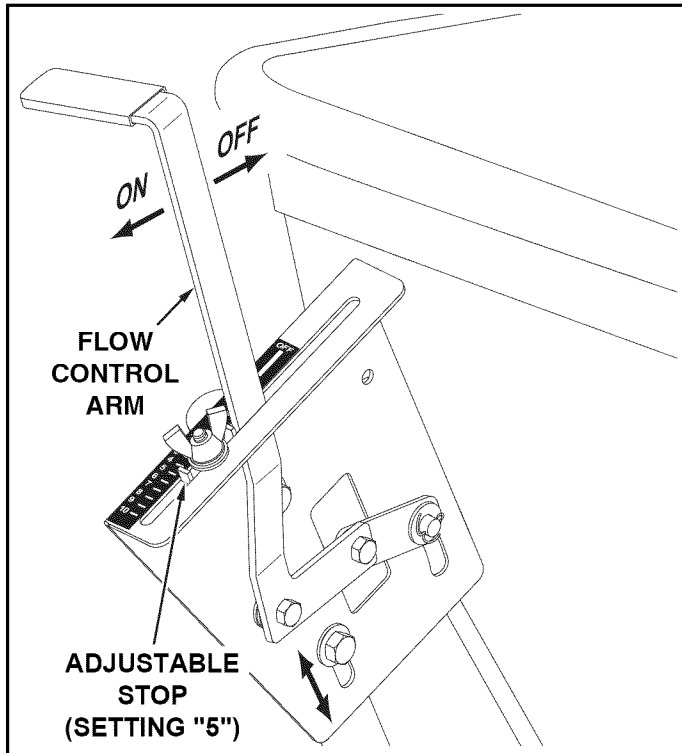

FIGURE 8

STEP 9: (SEE FIGURE 9)

- Place screen down into hopper, sliding edge of screen under one of the clips. Slightly bow the screen to slide opposite side of the screen under other clip.

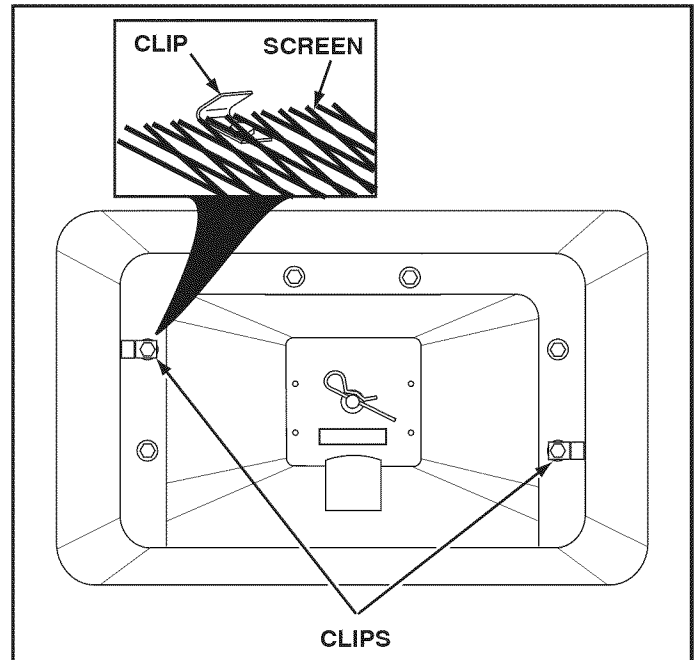

FIGURE 9

STEP 10: (SEE FIGURE 10)

- For most vehicles, you can keep the assembled hitch extension bracket in its default position shown in figure 10. Attach the spreader hitch to your vehicle hitch. Check for interference with the spreader directly behind and out to both sides of the vehicle. Lift the spreader at each position to make sure there is no interference with the spreader's flow control. If there is interference with the rear of the vehicle, assemble the hitch extension bracket as shown at the **bottom** of figure 10. **Tighten** bolts and nuts when finished.

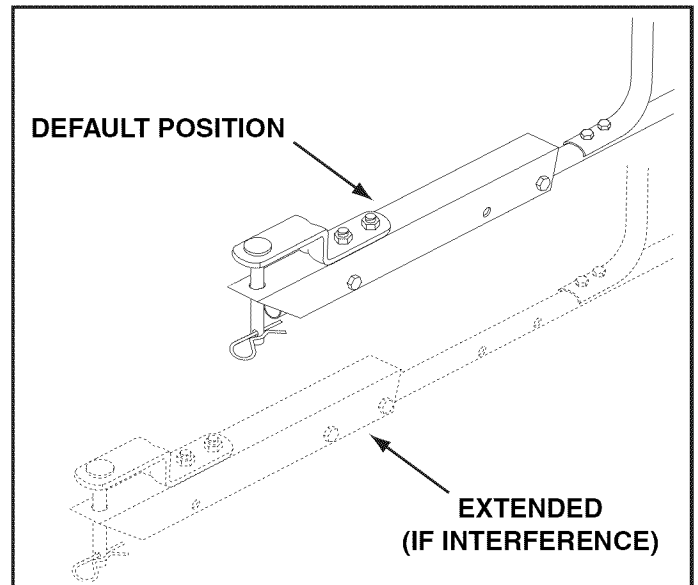

FIGURE 10

ACCESSORIES AND ATTACHMENTS

HOW TO USE YOUR SPREADER

SETTING THE FLOW CONTROL

(Refer to figure 8 on page 6.)

- Loosen the nylon wing nut, set the adjustable stop to the desired flow rate setting and retighten the wing nut. The higher the setting number, the wider the opening in the bottom of the hopper.
- Refer to the application chart on this page and to the instructions on the fertilizer bag to select the proper flow rate setting.
- Pull the flow control arm against the adjustable stop for the on position and toward the hopper for the off position.

THE FREE WHEELING FEATURE

(Refer to figure 4 on page 5.)

The spreader is equipped with a removable pin in the left (drive) wheel. Remove the pin to disengage the drive wheel so that the axle, gears and spreader plate do not rotate. With the drive wheel disengaged, the spreader may be towed at speeds up to 20 mph. If the drive wheel is engaged do not exceed 6 mph.

USING YOUR SPREADER

We do not recommend the use of any powdered lawn chemicals, due to difficulty in obtaining a satisfactory or consistent broadcast pattern.

- Determine approximate square footage of area to be covered and estimate amount of material required.
- Before filling the hopper make sure the flow control arm is in the off position and the closure plate is shut.
- Break up any lumpy fertilizer as you fill the hopper.
- Set the adjustable stop with the flow control arm still in the off position. Refer to the application chart on this page and to the instructions on the fertilizer bag to select the proper flow rate setting.
- The application chart is calculated for light to heavy application at a vehicle speed of 3 mph, or 100 ft. in 23 seconds. A variation in speed will require an adjustment of the flow rate to maintain the same coverage. The faster you drive, the wider the broadcast width.
- Make sure the drive pin is installed in the axle before starting the spreader.
- Always start the tractor in motion before opening closure plate.
- Always shut the closure plate before turning or stopping the tractor.
- If fertilizer is accidentally deposited too heavily in a small area, soak the area thoroughly with a garden hose or sprinkler to prevent burning of the lawn.

- To insure uniform coverage, make each pass so that the broadcast pattern slightly overlaps the pattern from the previous pass as shown in figure 11. The approximate broadcast widths for different materials are shown in the application chart on this page.
- When broadcasting weed control fertilizers, make sure the broadcast pattern does not hit evergreen trees, flowers or shrubs.
- Heavy moisture conditions may require a cover over the hopper to keep contents dry. The vinyl cover acts as a wind and moisture shield, but should not be used as a rain cover.

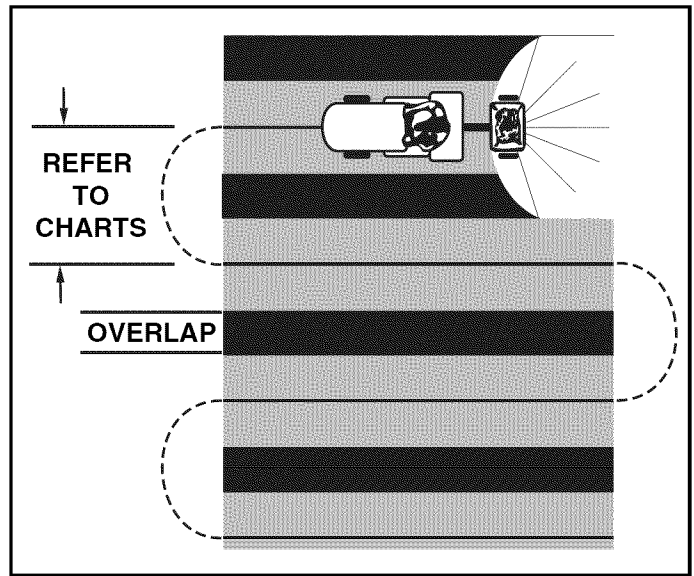

FIGURE 11

IMPORTANT: Application rates shown in the chart are affected by humidity and by the moisture content of the material (granular and pellet). Some minor setting adjustments may be necessary to compensate for this condition.

APPLICATION CHART		
TYPE MATERIAL	FLOW SETTING	SPREAD WIDTH
FERTILIZER		
Powder	3 - 5	3' - 4'
Granular	3 - 5	8' - 10'
Pelleted	3 - 5	10' - 12'
Organic	6 - 8	6' - 8'
GRASS SEED		
Fine	3 - 4	6' - 7'
Coarse	4 - 5	8' - 9'
ICE MELTER	6 - 8	10' - 12'

OPERATING SPEED - 3 MPH. (100 ft. in 23 seconds)

MAINTENANCE

CHECK FOR LOOSE FASTENERS

- Before each use make a thorough visual check of the spreader for any bolts and nuts which may have loosened. Retighten any loose bolts and nuts.

CHECK FOR WORN OR DAMAGED PARTS

- Check for worn or damaged parts before each use. Repair or replace parts if necessary.

CHECK TIRE INFLATION

- Check if tires are adequately inflated before each use. Do not inflate beyond maximum recommended pressure.



CAUTION: DO NOT inflate tires beyond the maximum recommended pressure printed on side of tire.

CLEANING

- Rinse inside of hopper and exterior of spreader and dry off before storing.

LUBRICATE (See figure 12)

- Lightly apply automotive grease as needed to the sprocket and gear.
- Oil the nylon bushings on the vertical sprocket shaft and on the axle at least once a year, or more often as needed.
- Oil right hand (idler) wheel bearing at least once a year or more often as needed.

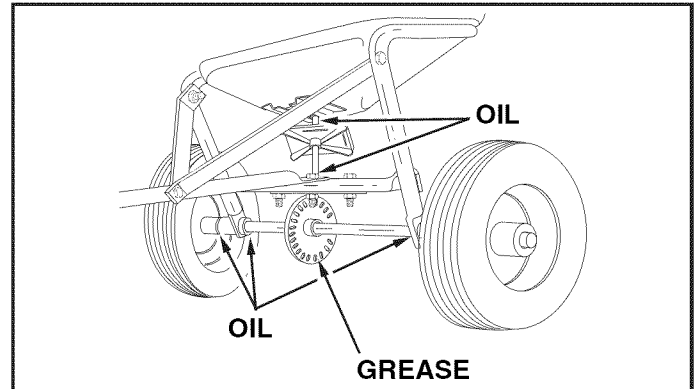

FIGURE 12

SERVICE AND ADJUSTMENTS

REPLACING SLOTTED GEAR

- If the axle, slotted gear and sprocket assembly is disassembled, mark down the positions of the parts as they are removed. The drive wheel and sprocket positions in relation to the slotted gear determine which direction the spreader plate will spin. Be sure to reassemble them in their original positions. (Refer to figure 4 on page 5.) Use shim washers (Ref. no. 21 on pages 10 and 11) as needed for minimum backlash. Add grease to gear and sprocket.

LOCKED UP SPREADER

- Turn the spreader over so that the wheels are off the ground.
- Loosen all three nuts on the shaft support plate just enough so that the bolts can be turned easily with a wrench but cannot be turned by hand.
- Spin the drive wheel and note how freely it spins and how much noise the slotted gear makes.
- To free up the wheel and gear, tap gently on the front or rear edge of the shaft support plate to move it slightly forward or backward. You can also tap at the corners of the plate to angle it slightly.
- Spin the drive wheel after each adjustment to see if it spins more freely and if the gear noise is reduced.

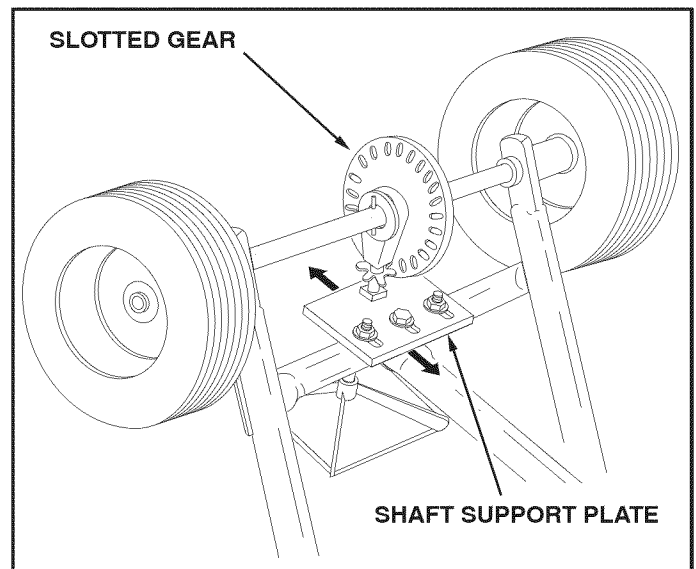

FIGURE 13

- Continue making slight adjustments until you find the position where the drive wheel spins most freely and the gear makes the least noise.
- Secure the shaft support plate in this position by retightening all three nuts that you loosened.

STORAGE

- Rinse inside of hopper and exterior of spreader and dry off before storing.
- Store in a clean, dry area.

REPAIR PARTS ILLUSTRATION

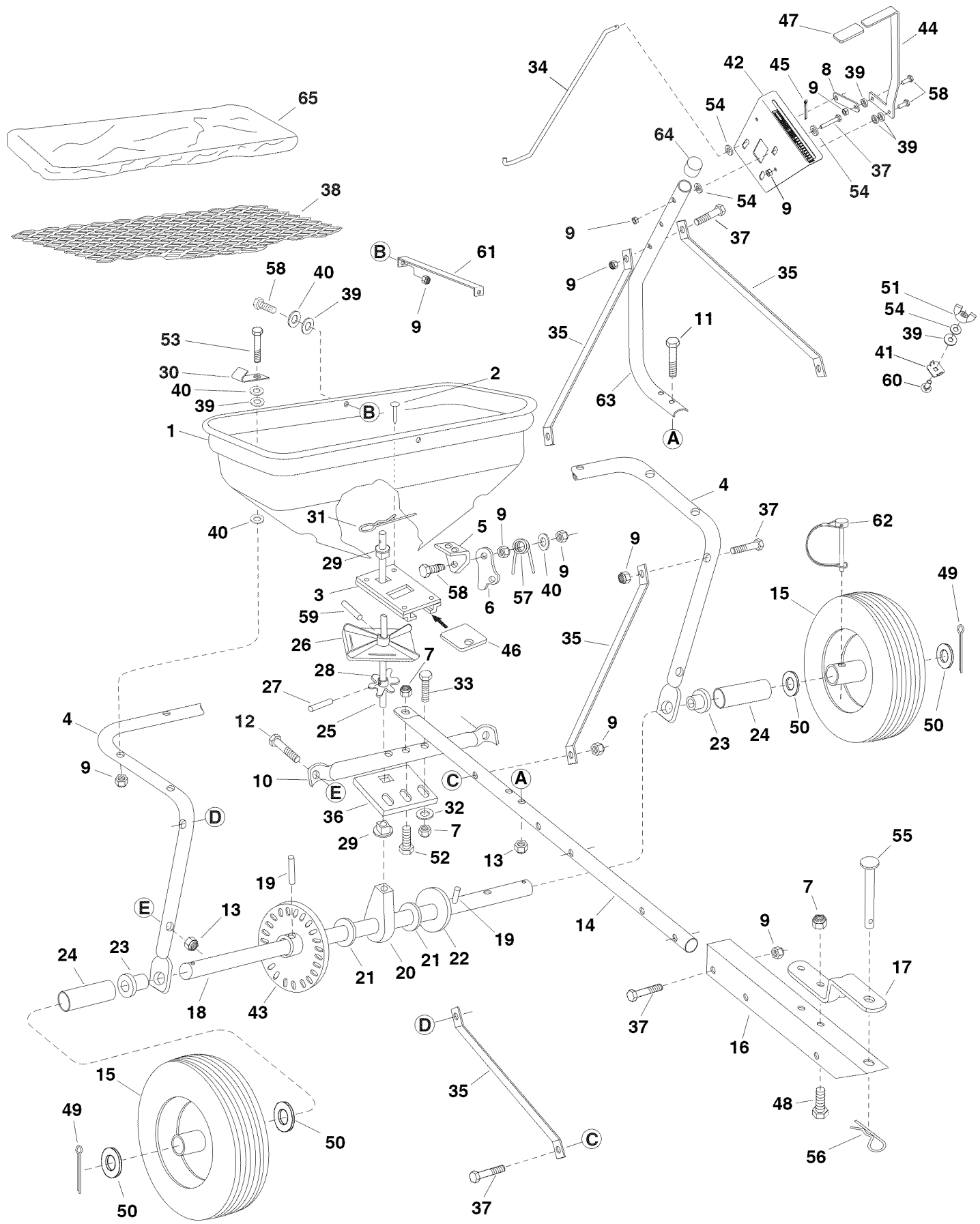

REPAIR PARTS

REF.	PART NO.	QTY.	DESCRIPTION	REF.	PART NO.	QTY.	DESCRIPTION
1	44480	1	Hopper	34	48586	1	Rod, Flow Control
2	43882	6	Rivet, Stainless	35	23525	4	Brace, Hitch
3	65129	1	Ass'y, Guide Closure	36	23762	1	Shaft Support Plate
4	44462	1	Tube, Frame	37	1509-69	8	Bolt, Hex 1/4-20 x 1-3/4"
5	23753	1	Slide Gate Angle Bracket	38	47441	1	Screen
6	23758	1	Slide Gate Bracket	39	1543-69	12	Washer, Nylon
7	HA21362	6	Nut, Nylock Hex 3/8-16 Thd.*	40	43088	15	Washer, Flat 1/4" Std.
8	24857	1	Flow Control Link	41	24858	1	Stop, Adjustable
9	47189	18	Nut, Nylock Hex 1/4-20 Thd.*	42	24915	1	Bracket, Flow Control Mount
10	43808	1	Tube, Crossover	43	62474	1	Gear Assembly
11	43084	2	Bolt, Hex 5/16-18 x 1-3/4" Lg.	44	24917	1	Flow Control Arm
12	44180	2	Bolt, Hex 5/16-18 x 2"	45	44101	1	Cotter Pin 3/32" x 3/4" Lg.*
13	47810	4	Nut, Nylock Hex 5/16-18 Thd.*	46	23533	1	Plate, Closure
14	48864	1	Tube, Hitch	47	43848	1	Grip, Flow Control Arm
15	48511	2	Wheel	48	43407	2	Bolt, Hex 3/8-16 x 3/4" Lg. *
16	25080	1	Bracket, Hitch Extension	49	43093	2	Pin, Cotter 1/8" x 1-1/2"
17	23014	1	Bracket, Hitch	50	43009	4	Washer, Flat 3/4"
18	24914	1	Shaft, Axle	51	47141	1	Wing Nut, Nylon
19	43851	2	Pin, Spring 3/16" Dia. x 1-1/4" Lg.	52	HA180132	1	Bolt, Hex 3/8-16 x 2-1/4" Lg. *
20	43871	1	Bushing, Axle Shaft	53	46699	6	Bolt, Hex 1/4-20 x 2-1/2"
21	1540-32	5	Washer, Flat .78 I.D.	54	R19111116	6	Washer, 5/16 SAE
22	1540-162	1	Washer, Flat 1/2"	55	47623	1	Hitch Pin
23	47615	2	Bearing, Flange	56	43343	1	Hair Cotter Pin, 1/8"
24	47683	2	Tube, Spacer	57	44566	1	Spring, Torsion
25	25305	1	Shaft, Sprocket	58	43661	5	Bolt, Hex 1/4-20 x 1" Lg.*
26	04367	1	Spreader Plate	59	46055	1	Pin, Spring 1/8" Dia. x 1" Lg.
27	43850	1	Pin, Spring 1/8" Dia. x 5/8".	60	44950	1	Bolt, Carriage 1/4-20 x 3/4"
28	44468	1	Sprocket, 6 Tooth	61	23697	1	Hopper Strap
29	44285	2	Bushing, Delrin	62	48515	1	Drive Pin W/Bail, 1/4" x 2"
30	25672	2	Clip	63	48514	1	Flow Control Mounting Tube
31	48934	1	Hairpin Agitator	64	44481	1	Vinyl Cap
32	43070	5	Washer, Flat 3/8" *	65	40825	1	Vinyl Cover
33	43054	2	Bolt, Hex 3/8-16 x 2" Lg.*		42012	1	Owner's Manual

* Purchase standard hardware locally.

Get it fixed, at your home or ours!

Your Home

For expert troubleshooting and home solutions advice:

manage my home

www.managemyhome.com

For repair – **in your home** – of **all** major brand appliances, lawn and garden equipment, or heating and cooling systems, **no matter who made it, no matter who sold it!**

For the replacement parts, accessories and owner's manuals that you need to do-it-yourself.

For Sears professional installation of home appliances and items like garage door openers and water heaters.

1-800-4-MY-HOME[®] (1-800-469-4663)

Call anytime, day or night (U.S.A. and Canada)

www.sears.com www.sears.ca

Our Home

For repair of carry-in items like vacuums, lawn equipment, and electronics, call anytime for the location of your nearest

Sears Parts & Repair Service Center

1-800-488-1222 (U.S.A.)

www.sears.com

1-800-469-4663 (Canada)

www.sears.ca

To purchase a protection agreement on a product serviced by Sears:

1-800-827-6655 (U.S.A.)

1-800-361-6665 (Canada)

Para pedir servicio de reparación a domicilio, y para ordenar piezas:

1-888-SU-HOGAR[®]

(1-888-784-6427)

Au Canada pour service en français:

1-800-LE-FOYER^{MC}

(1-800-533-6937)

www.sears.ca

Sears

© Registered Trademark / TM Trademark / SM Service Mark of Sears Brands, LLC

© Marca Registrada / TM Marca de Fábrica / SM Marca de Servicio de Sears Brands, LLC

^{MC} Marque de commerce / ^{MD} Marque déposée de Sears Brands, LLC

© Sears Brands, LLC