

Amana®

Standard Door Top Mount Refrigerator Installation¹ Instructions

ATTENTION INSTALLER:

Please read these instructions.

Amana Refrigeration, Inc., will not pay warranty claims caused by improper installation.

| | |
|--|----|
| SAFETY INSTRUCTIONS | 2 |
| PROPER USE OF AN APPLIANCE "DOLLY" | 2 |
| REMOVING WOODEN BASE ("SKID") | 3 |
| REMOVING REFRIGERATOR DOORS..... | 5 |
| CONNECTING WATER FOR FACTORY INSTALLED AUTOMATIC ICE MAKER | 14 |
| MOVING THE REFRIGERATOR INTO PLACE/ELECTRIC REQUIREMENTS | 20 |
| LEVELING REFRIGERATOR | 21 |
| REVERSING REFRIGERATOR DOORS | 23 |
| SETTING CONTROLS | 31 |
| 1/16" DECORATOR DOOR PANEL INSTALLATION | 32 |
| AMANA ASSURE | 32 |

CONSUMER INFORMATION LINE

AMANA TOLL FREE
1-800-843-0304

Amana®
A **Raytheon** Company

Safety Instructions



RECOGNIZE THIS SYMBOL AS A SAFETY PRECAUTION

Proper use of an appliance dolly

Procedure

1. Leave tape on refrigerator doors.
2. Wipe dirt from cart wheels to prevent damaging the floor.
3. Slide appliance cart under side of refrigerator opposite hinges.

4. Thread strap from cart around refrigerator, putting strap between refrigerator door and door handle. See Figure 1.
5. Put foam shipping pads, located in shipping carton, under strap to protect refrigerator trim.
6. Tighten strap, but do not over-tighten.
7. Protect floor.
8. Move refrigerator to location.
9. Loosen cart straps from around refrigerator.
10. Slide cart from underneath refrigerator.
11. Remove remaining package materials from exterior and interior of refrigerator.

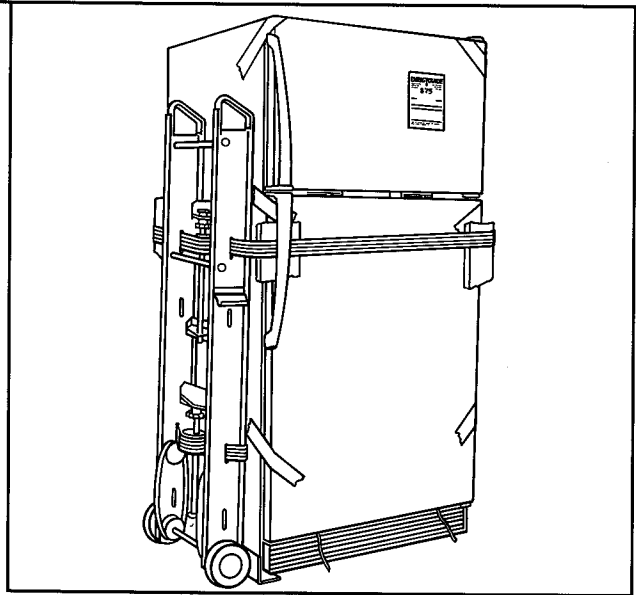

Figure 1

Remove skid (wooden base)

Recommended Tools

- 7/16 inch hex head socket/wrench
- Blanket
- Tightly fitted gloves
- Appliance Cart

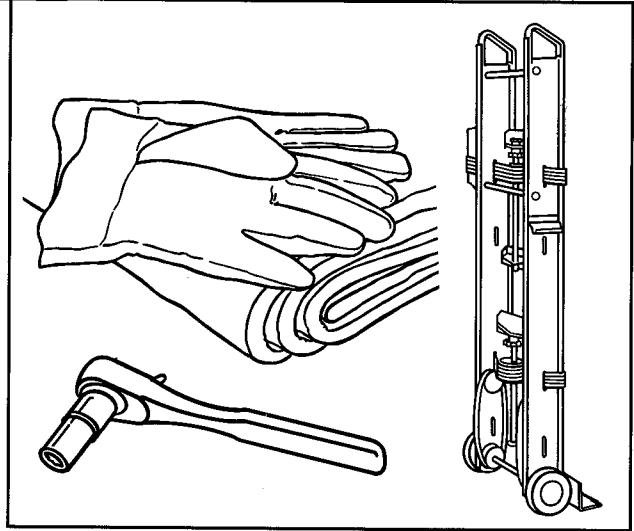

Figure 2

Procedure

1. Removing wooden base (skid) will require two strong individuals.
2. Leave tape on refrigerator doors.
3. Slide appliance cart under side of refrigerator opposite hinges.
4. Thread strap from cart around refrigerator, putting strap between refrigerator door and door handle. See Figure 3.
5. Put foam shipping pads, located in shipping carton, under strap to protect refrigerator trim.
6. Tighten strap, but do not over-tighten.
7. Gently lower the appliance cart so handles are resting on the floor.

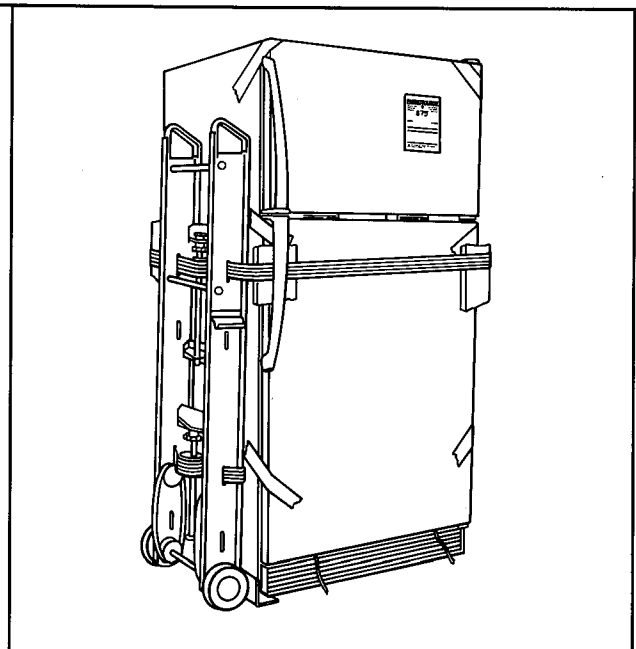

Figure 3

8. Using 7/16" hex head socket/wrench, remove bolts from skid. See Figure 4.

9. Gently return refrigerator and cart to an upright position.

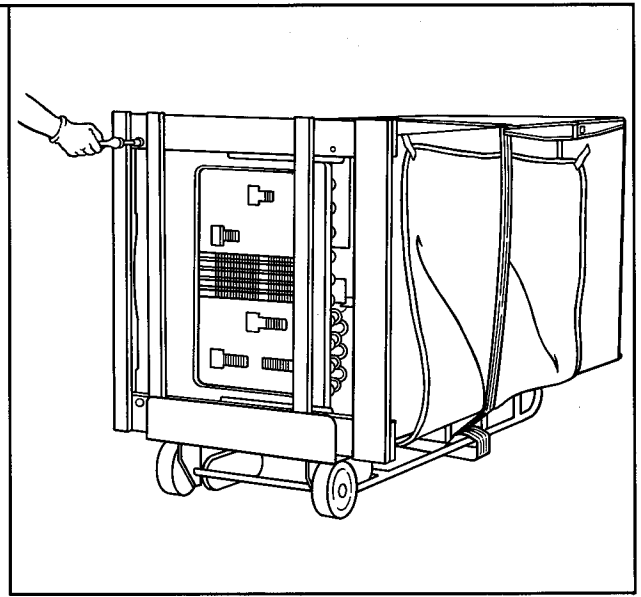

Figure 4

10. Slide cart between refrigerator and skid on the opposite side and gently lower the dolly so handles are resting on the floor. See Figure 5.

11. Using 7/16" hex head socket/wrench, remove remaining two bolts from skid.

12. Discard bolts and wooden base.

13. Gently return refrigerator and cart to an upright position and remove cart from underneath refrigerator.

14. Do not leave refrigerator on its side longer than necessary to remove bolts.

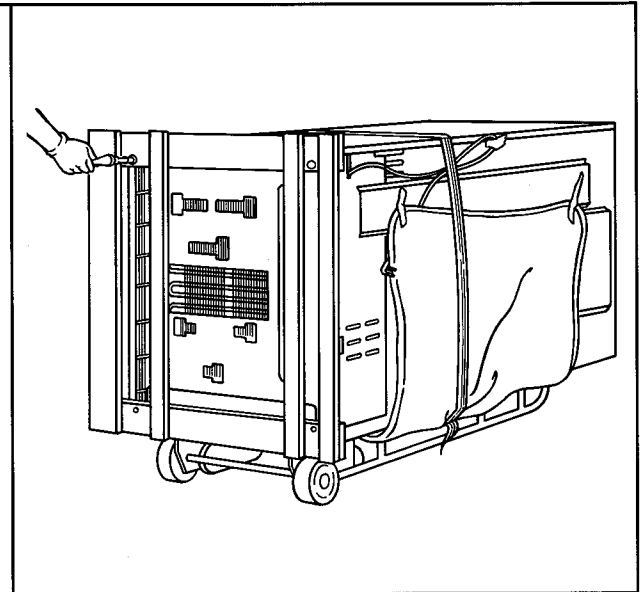

Figure 5

Door removal and replacement

If refrigerator doors need to be removed to fit through entry doors, complete the following steps, otherwise proceed to page 14.

In some cases, only handles may need to be removed to fit refrigerator through doorway. Refer to pages 26-27, Step 4 for directions.

Recommended Tools

- Tightly fitted gloves
- 5/16" hex nut driver
- Phillips screwdriver
- 3/8-inch hex head socket/wrench
- Screwdriver
- Strapping tape
- Blanket or moving pad

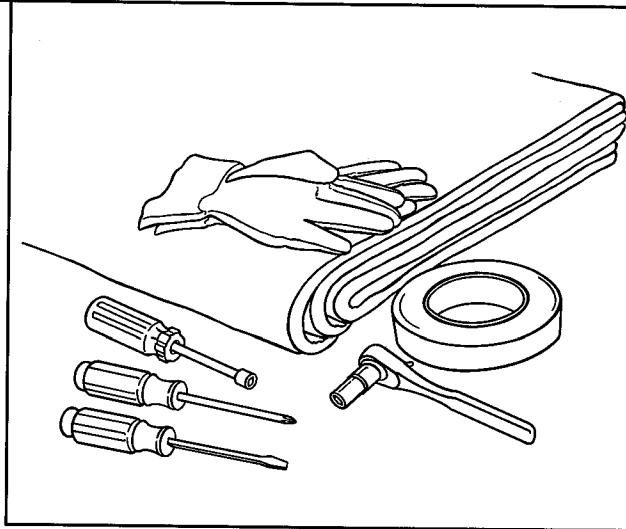

Figure 6

⚠ CAUTION: To Avoid Personal Injury Or Property Damage from falling doors during removal and installation of doors: Temporarily tape both doors shut with strapping tape on top right and left corners of each door. See Figure 7.

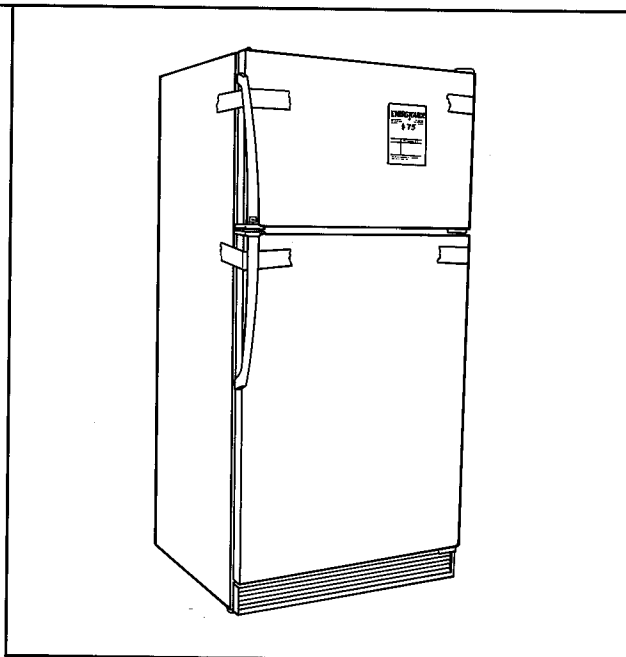

Figure 7

Procedure

1. Remove top hinge cover (on some models).
 - a. Lift back of hinge cover about 1/4".
 - b. Slide hinge cover toward front and off hinge. See Figure 8.
 - c. Trace around the outside of hinge with a pencil. This allows easier aligning when reassembling.

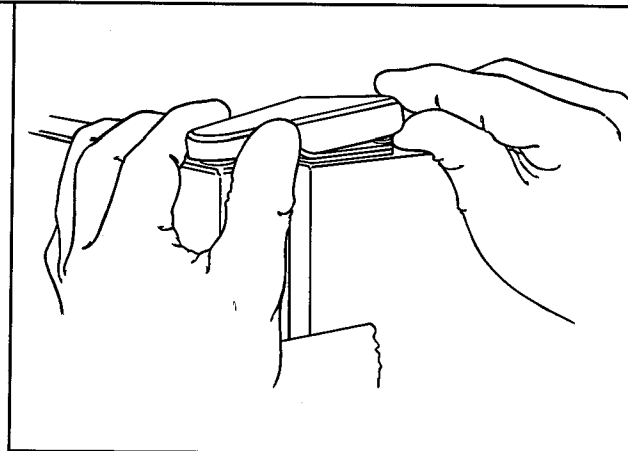

Figure 8

2. Free top hinge of freezer door.
 - a. Remove three 5/16" hex head screws with a 5/16" hex nut driver. See Figure 9.
 - b. Pull hinge upward to release freezer door.

⚠ CAUTION: To Avoid Risk of Personal Injury or Property Damage have (2) two people help remove each door, one person to hold door while the other removes strapping tape.

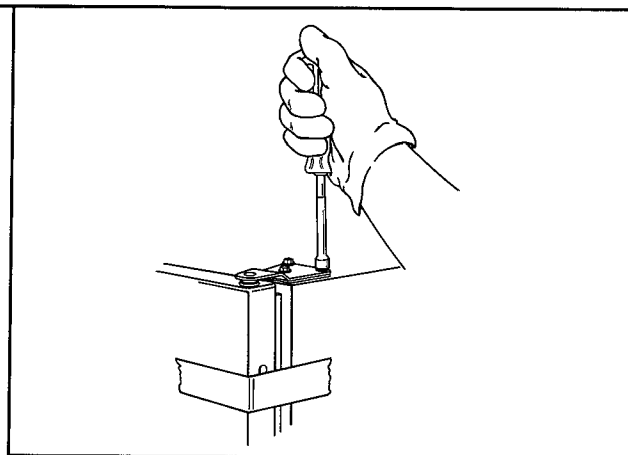

Figure 9

⚠ CAUTION: To Avoid Personal Injury or Property Damage: Do NOT allow door to drop to floor; to do so could damage door.

- c. Save plastic top hinge plate spacer(s) and all unattached plastic hinge spacer ring(s) from underneath top hinge plate pin and use in Step 12. See Figure 10.

NOTE: Some refrigerators may not have spacer(s).

3. Remove freezer door.
 - a. Remove tape from freezer door.
 - b. Grasp freezer door securely and lift upward as you open it. This will free door from center hinge pin and you can set it aside.
 - c. Lay door down on blanket or moving pad.
 - d. At no time should door rest on its bottom edge after removal.

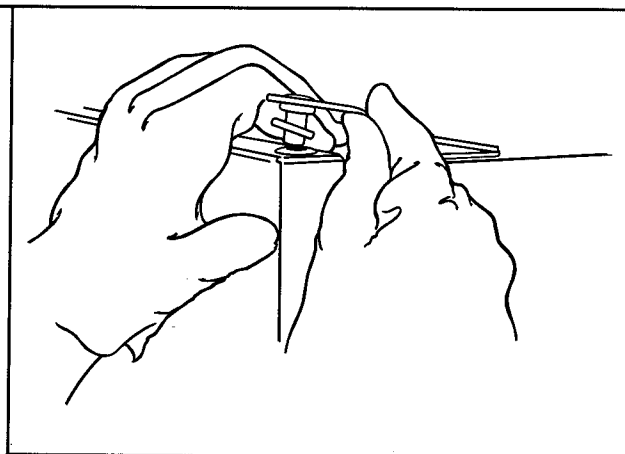

Figure 10

4. Remove center hinge pin.

- a. Save plastic center hinge spacer ring(s) from center hinge pin and use in Step 14. See Figure 11.

NOTE: Some refrigerators may not have spacer ring(s).

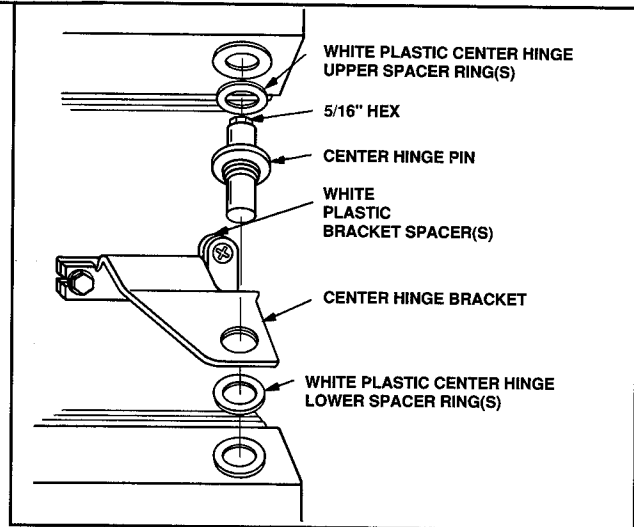

Figure 11

- b. Use a 5/16" nut driver to remove center hinge pin. See Figure 12.

- c. Pull hinge pin straight up to release it from refrigerator door.

- d. Save plastic center hinge spacer ring(s) from center hinge pin bracket and top of door and use in Step 14. See Figure 11.

NOTE: Some refrigerators may not have spacer ring(s).

5. Remove refrigerator door.

- a. Remove tape from refrigerator door.

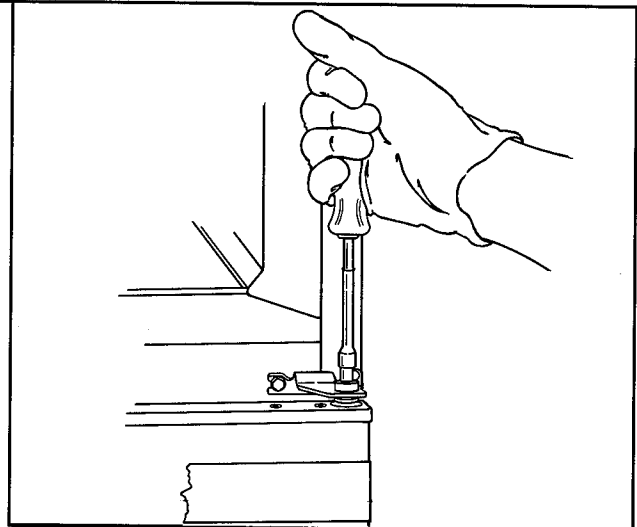

Figure 12

- b. Grasp refrigerator door securely and lift door upward as you open it. This will free refrigerator door from bottom hinge pin plate. See Figure 13.

- c. Lay door down on blanket or moving pad.

6. Remove center hinge bracket (if needed to get through doorway).

- a. Remove center hinge bracket and plastic bracket spacer(s) from center right side of refrigerator by removing two Phillips head screws and one 5/16" hex head screw. Save all parts for use in Step 14.

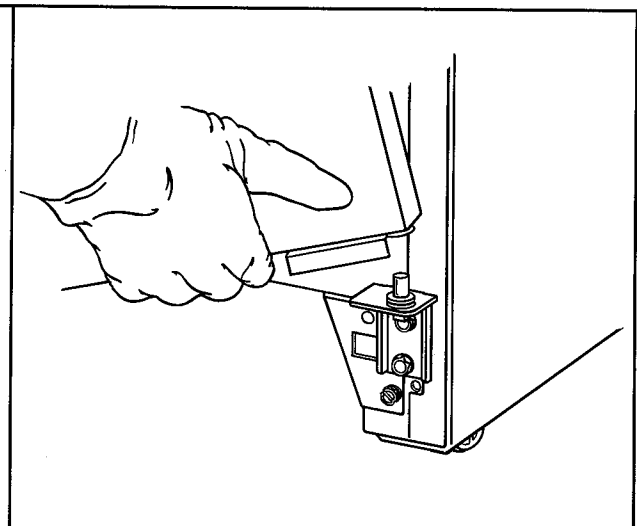

Figure 13

7. Remove toe grille by pulling forward at both ends.

8. Remove bottom hinge bracket (if needed to get through doorway).

a. Use a ratchet wrench and 3/8" hex socket to remove hex head screws and bottom hinge bracket from bottom right side of cabinet. See Figure 14.

b. Save all white bottom hinge spacer ring(s) from top of bottom hinge pin and bottom hinge spacers from bottom bracket.

NOTE: If rings and pin are missing, check bottom of refrigerator door. It is very important rings and pin are placed in same position as originally shipped from the factory. Do not misplace.

9. Move refrigerator into place.

10. Place bottom hinge bracket into position.

a. Place bottom hinge spacers between bottom hinge bracket and refrigerator.

b. Tighten hinge with 3/8" hex head screws. See Figure 15.

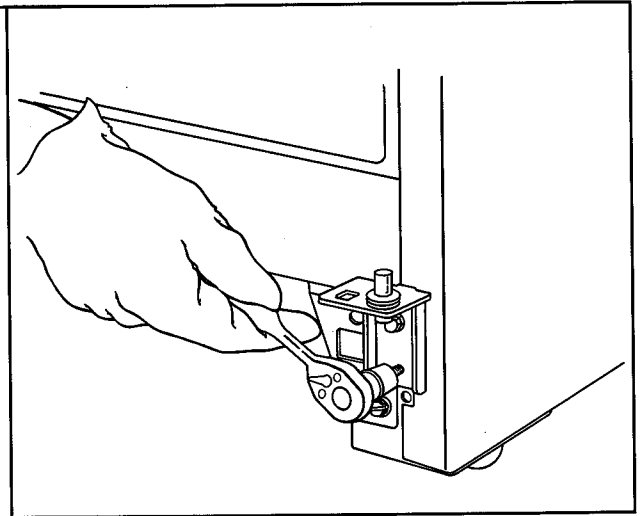

Figure 14

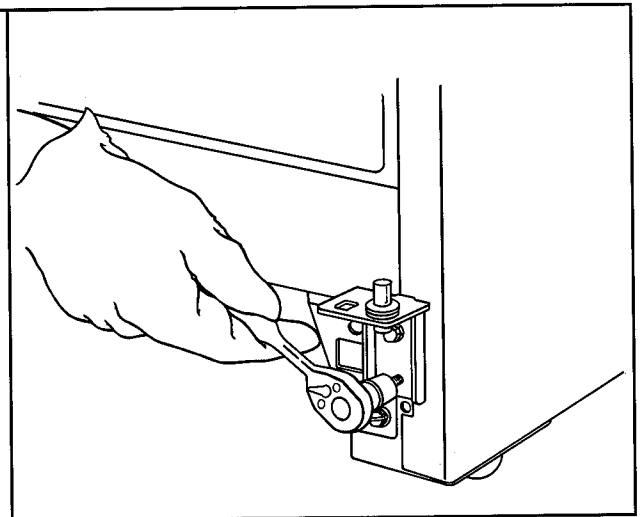

Figure 15

11. Place center hinge bracket in position.

- a. Place all plastic bracket spacer(s) in between center hinge bracket and refrigerator. See Figure 16.
- b. Screw in a 5/16" hex head screw and two Phillips screws by hand through end of center hinge bracket. Take care not to overtighten.

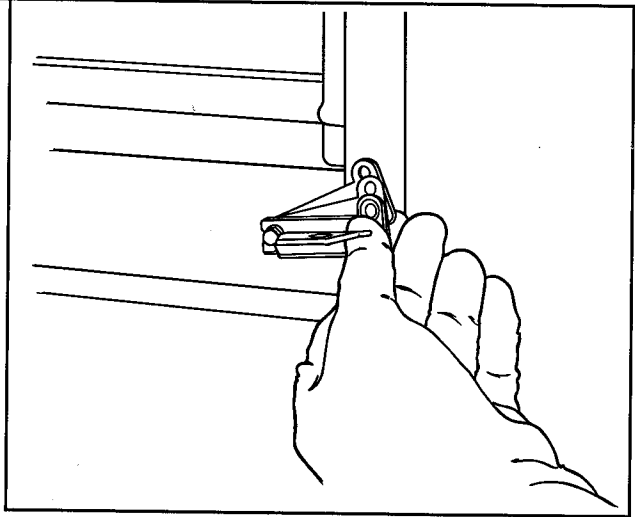

Figure 16

- c. Secure bracket by tightening the two Phillips head screws. Tighten 5/16" hex head screw to secure bracket. See Figure 17.

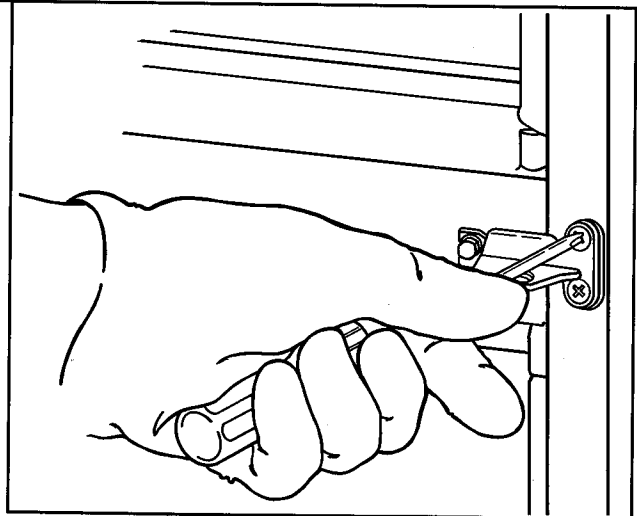

Figure 17

12. Place top hinge plate in position.

- a. Place top plastic hinge plate spacer(s) on top of refrigerator.
- b. Place top hinge plate on top of spacers on top right side of refrigerator. See Figure 18.
- c. Turn top two screws closest to back of hinge. Leave front screw out.

⚠ CAUTION: To Avoid Risk of Personal Injury or Property Damage have (2) two people help rehang each door, one person to hold door while other secures the hinge pin.

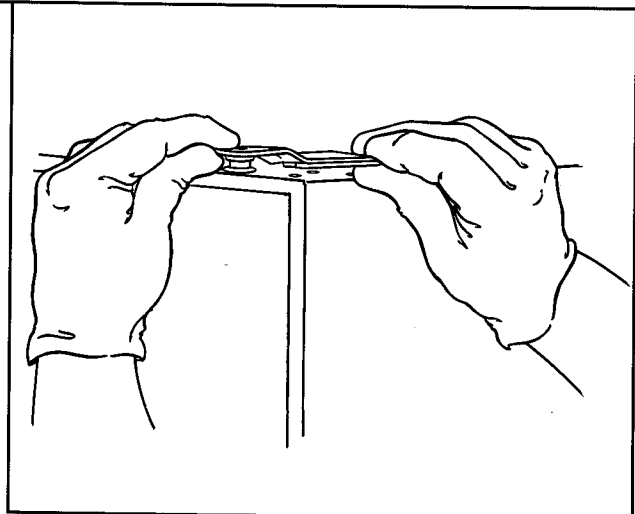

Figure 18

13. Rehang refrigerator door.

NOTE: All shims and spacer rings must be in place on lower hinge pin assembly before hanging door.

- a. Place door on cabinet by fitting bottom right socket over pin on bottom hinge bracket. See Figure 19.

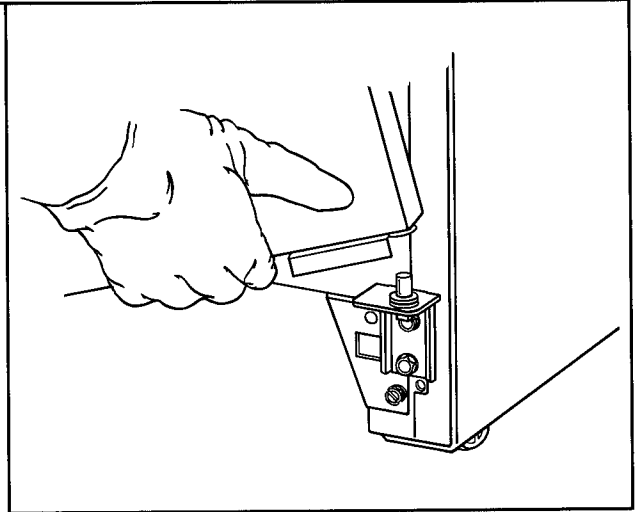

Figure 19

14. Center hinge assembly.

- a. Install all of the plastic center spacer ring(s) in the same position as in Steps 4a, 4d, and 6a. See Figure 20.

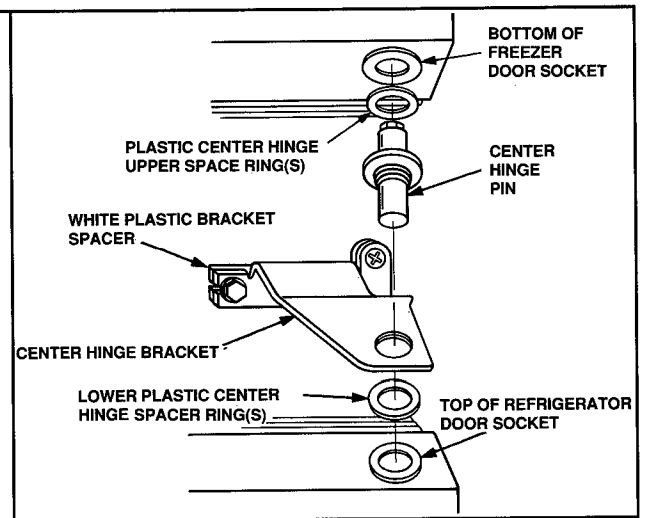

Figure 20

b. Holding door shut, reinstall center hinge pin so pin fits through bracket and into door socket. See Figure 21.

c. Secure hinge pin with 5/16" nut driver.

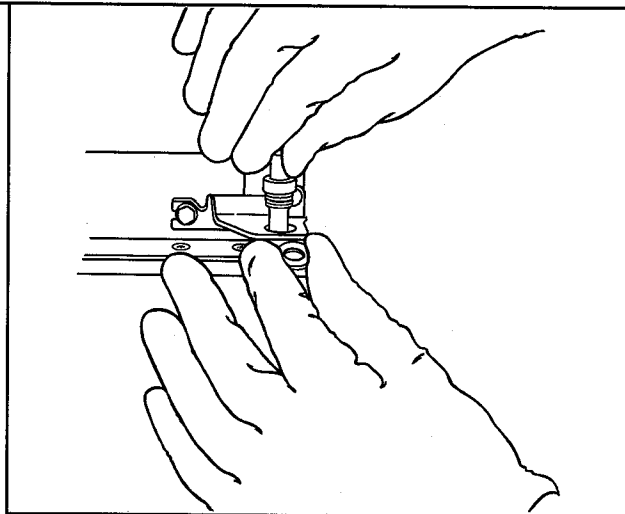

Figure 21

15. Check light switch operation.

a. Ease door slowly shut and visually observe if refrigerator doorliner engages on/off light switch to assure door is shutting off light when door is in closed position. See Figure 22.

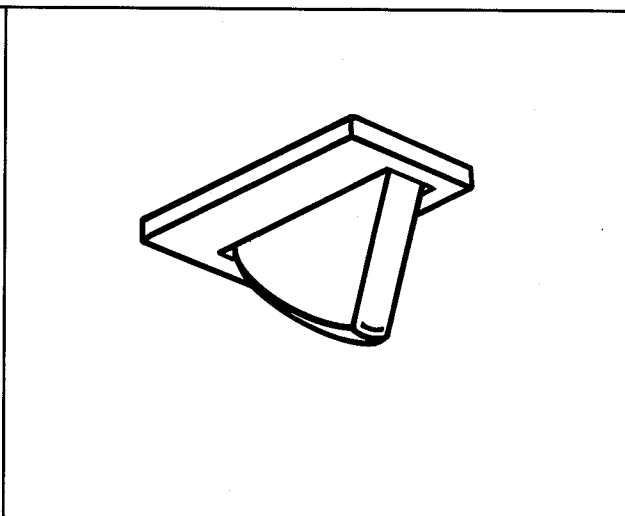

Figure 22

16. Rehang freezer door.

a. Position all plastic spacer rings from Step 2c and 4a on top hinge.

b. Place door on cabinet by fitting bottom right socket over pin on center hinge. See Figure 23.

c. Push door toward cabinet, lifting top hinge so pin fits into top right door socket.

d. Install third (front) top hinge screw.

e. Align hinge with outline of hinge traced in Step 1C.

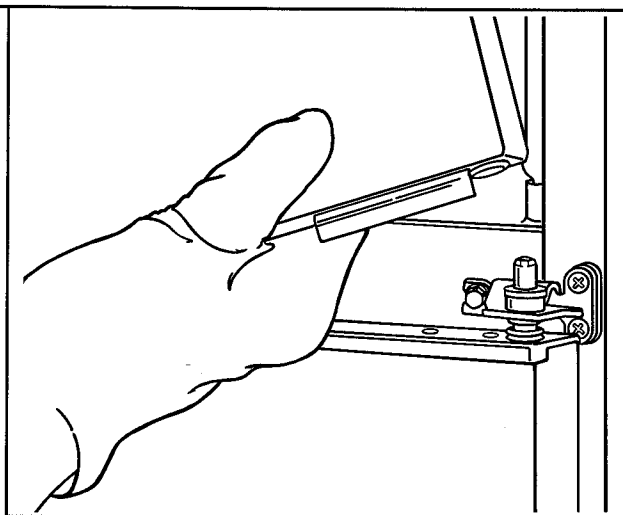

Figure 23

- f. Secure door by 'snugging' screws partially tight with 5/16" hex head screwdriver into top hinge. See Figure 24.

17. Align freezer door from side-to-side and top-to-bottom.

- a. Top hinge adjusts from front-to-back and side-to-side.
- b. Loosen top hinge screw and adjust so door is flush with side of refrigerator cabinet.
- c. Handle side of door should be approximately 1/8" higher than top of refrigerator. The door will settle when loaded with food. Tighten top hinge screws.

18. Check freezer light switch operation.
See Step 15.

19. Replace top hinge covers.

- a. Position back lip of hinge cover over grooves.
- b. Snap back into place.
- c. Install the bottom toe grille.

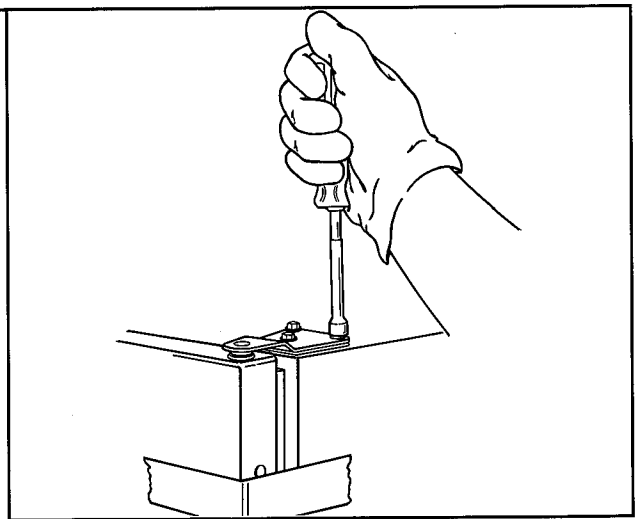



Figure 24

Read and understand the following safety instructions before proceeding with installation.

 **WARNING:** To avoid the risk of electrical shock, which can cause severe personal injury or death, observe the following precautions:

1. Disconnect refrigerator from its electrical power source.
2. Make absolutely certain that electric drill being used is properly grounded and/or double insulated.
3. Do not drill into a water pipe until water has been shut off and pipe has drained through a faucet at some low point in water system.
4. If a horizontal water pipe is chosen, drill only into side or top of it. Drilling on underside can allow trapped water to enter drill and cause electrical shock.

 **CAUTION:** Failure to observe the following may result in damage to your appliance or to other property:

1. Use care to ensure that you drill through only one wall of water pipe in preparation for saddle valve installation.
2. Check carefully for any water leaks following installation of saddle valve, and before returning refrigerator or freezer to its normal location.
3. Always start tubing nuts by hand, to avoid cross threading. Finish tightening nuts using an adjustable wrench or a 1/2 inch open end wrench.

Kit Installation Procedure

For best results, perform installation procedure in order given below. Doing so will minimize time during which household water supply is turned off, and time during which refrigerator must be disconnected.

Note that unless otherwise stated, all parts referenced throughout installation procedure are from water supply hookup kit.

1. Install water supply saddle valve and connect copper tubing:

- a. A suitable cold water pipe should have been selected prior to purchasing 1/4 inch copper tubing that will carry ice making water to refrigerator or freezer. If convenient, a vertical pipe is preferred.

- b. Shut off household water supply at main water valve.
- c. Open a cold water faucet, at some low point in water system. Allow cold water system to drain until water no longer flows from faucet.
- d. Select exact spot on water pipe at which hole is to be drilled, and mark spot using a center punch and hammer.
- e. Drill a 1/4 inch hole through top or one side wall of selected pipe, as applicable. **Use care to avoid drilling through opposite wall of pipe.**

NOTE: Use only saddle valve supplied with water supply hookup kit, or an identical valve. Do not use a self-piercing type, as it may become restricted due to the small hole the piercing type valve makes in water pipe.

f. Attach saddle valve to water pipe using parts illustrated in Figure 26. Thread valve to saddle valve clamp. Make sure rubber washer is in place between saddle valve clamp and water pipe. Also note saddle valve clamp must be threaded onto saddle valve stem before clamping saddle valve to water pipe. **NOTE: Valve will not thread completely into saddle valve clamp because of tapered threads.** Tighten two attaching screws evenly, in increments so spacing is equal between both sides of clamps. **Do not overtighten.**

g. Slip brass nut and brass sleeve onto 1/4 inch copper tubing as shown in Figure 26.

h. Insert 1/4" copper tubing to saddle valve outlet port, making sure tube is inserted fully. Be sure to start nut by hand, turning clockwise, to avoid cross threading. Firmly connect copper tube to saddle valve outlet fitting using a 1/2 inch open end wrench to secure brass nut. **NOTE: Pull on copper tubing to see if tubing is secured to coupling.**

i. Shut off saddle valve, by turning handle fully clockwise, and then turn on household water supply valve.

j. Make certain there are no leaks in connections, and saddle valve shuts off water completely before proceeding.

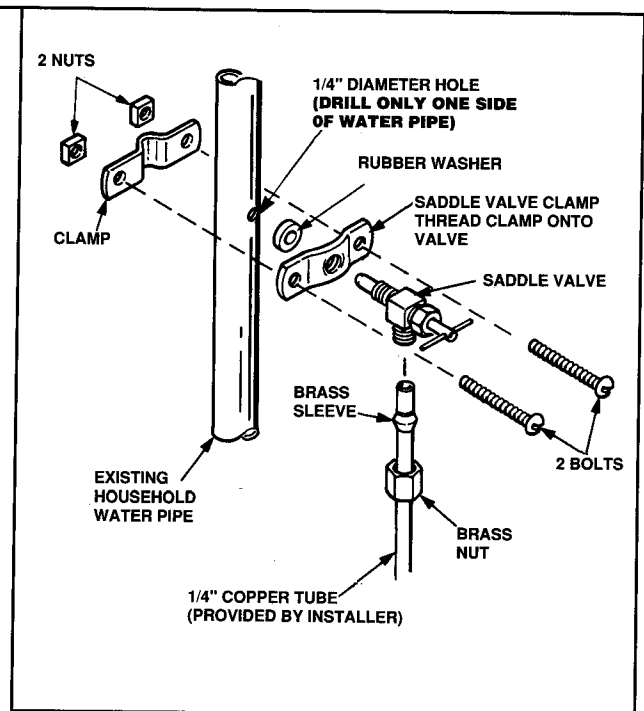

Figure 26

2. Protect floor when moving refrigerator with thin 1/4" plywood strips or scrap pieces of linoleum under wheels. Unplug refrigerator power cord from its electrical outlet, and then pull refrigerator away from wall. Position refrigerator so its back is accessible.

- a. Route copper tube up to refrigerator, through floor or interior wall behind refrigerator, whichever is more convenient, using 3/8" holes when required.
- b. Put other end of copper tubing into a sink, or a pail if desired, and open saddle valve slightly. Keep in mind that water will be under considerable pressure. Allow water to run through copper tubing for several minutes to flush out saddle valve and copper tubing. Shut off saddle valve when flushing is completed.

3. Remove the lower cover from the back of the refrigerator. See Figure 27. Do not discard the lower cover; it must be reinstalled after the ice maker kit installation is completed.

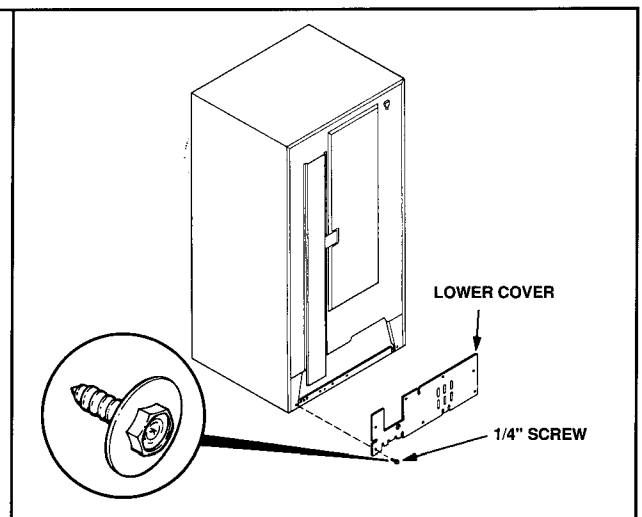

Figure 27

4. Remove brass nut and brass sleeve from adapter fitting. See Figure 28.

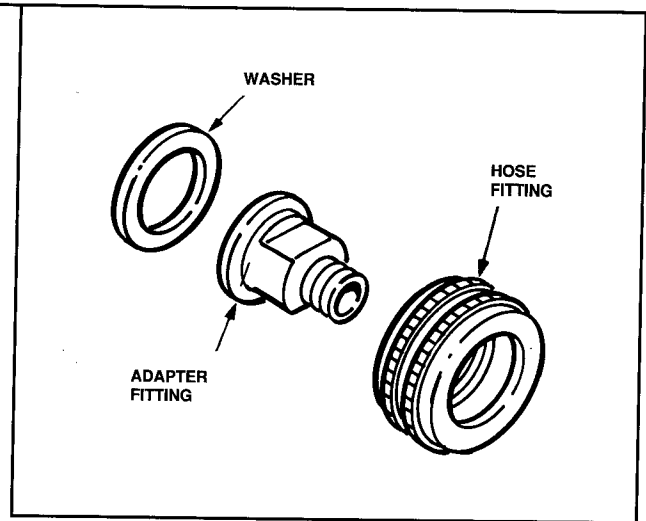

Figure 28

5. Slip brass nut and brass sleeve over end of 1/4 inch copper tube. *Make sure you start brass nut by hand to avoid cross threading.* Insert 1/4" tube completely into adapter fitting using two 1/2" open end wrenches, and secure with one to hold brass nut on tube and other to hold 1/2" flat on hose adapter. See Figure 29. **NOTE: Pull on copper tubing to see if the tubing is secured to adapter fitting.**

6. Check hose fitting to assure washer is in place.

7. Connect hose fitting to water valve. Tighten hose fitting as far as possible by hand, being careful not to cross thread hose fitting to water valve, then carefully tighten it an additional 1/2 turn using pliers.

8. Open saddle valve and check for leaks around valve inlet fitting, and around brass nut and adaptor fitting. If leaks are present tighten fittings until leaks stop.

9. Before reinstalling lower rear cover on refrigerator, and before moving refrigerator back to its normal position, plug refrigerator in and allow it to run long enough for valve to open, and ice maker to begin operation. Note that saddle valve must be fully opened (turned counterclockwise \odot) to make this check. While ice maker is operating, check connections on both copper tube and plastic tube for leaks. Also check to be sure water extension tube in freezer compartment remains firmly in place on water tube and water enters water cup properly.

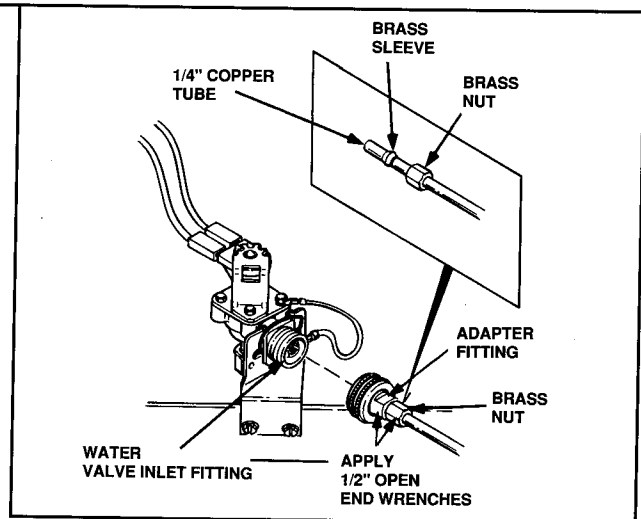

Figure 29

10. When you are confident that no leaks exist or after correcting any apparent leaks, install lower cover on back of refrigerator. Clamp copper tube to back of unit using "P" clamp provided in kit and upper right attaching screw of lower cover. Using extreme care to avoid kinks, put a service loop in copper tube as shown in Figure 30.

CAUTION: Lower rear cover must be in place for proper operation of refrigerator.

11. Move refrigerator back to its normal position and turn freezer control to mid-position.

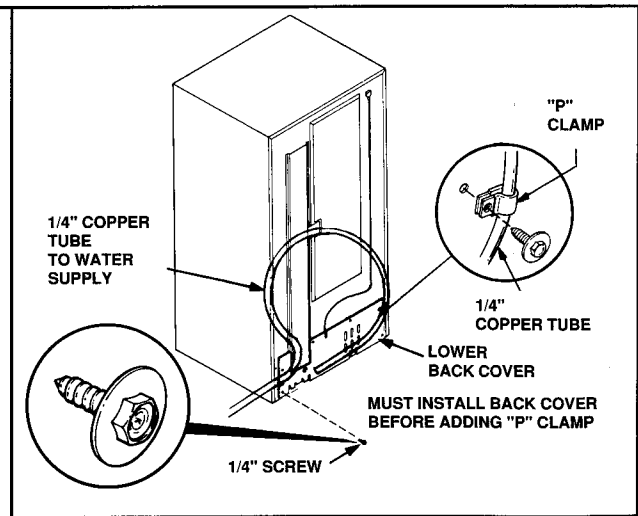

Figure 30

Operation of Ice Maker

1. Check to be sure that ice storage bin is in place, that ice maker shut-off arm is in "Down" position and that saddle valve is open (handle fully counterclockwise).

2. After freezer reaches normal temperature ice cubes will be produced.

3. Ice will now be lifted out of ice maker after it is formed, and be deposited in ice bin. This will continue until ice bin is filled, at which time ice maker will automatically shut off.

4. To stop ice maker at any time, lift shut off arm to upper detent position. A definite "click" will be heard when upper detent position is reached, and shut-off arm will remain in that position.

5. As ice maker operates, sounds of ice maker motor and ejector, and sounds of ice dropping into bin will be heard. All these sounds are normal.

NOTE: First three batches of ice should be discarded, since they may contain contaminants from ice maker or from water system.

CAUTION: Before leaving on vacation, or other extended absence, shut off water supply to ice maker at saddle valve and move ice maker shut-off arm to "up" position. Failure to do this may result in possible property damage.

If preceding installation instructions were carefully followed, there is little chance that ice maker will fail to function properly. In the event that ice maker does fail to function properly, the following checks should be made by you, the owner, prior to contacting an authorized Amana Servicer. In general, give ice maker one overnight period before assuming that a problem exists.

NOTE: Ice maker is designed to produce up to eight (8) pounds of ice in a 24 hour period under ideal conditions of room temperature, water inlet pressure and freezer compartment interior temperature. If low ice production is experienced, preceding conditions should be considered before assuming a problem with ice maker itself. A freezer compartment interior temperature above +20° F will noticeably affect ice production, as will room temperatures above 75° F.

 **WARNING:** To avoid risk of electrical shock, which can cause severe personal injury or death, disconnect refrigerator from its power source before attempting any disassembly.

1. Check to make sure that saddle valve installed on household water pipe is fully turned on (handle fully counterclockwise).
2. Make sure that ice maker wiring harness plug pins are fully inserted into their proper holes in receptacle at rear of freezer compartment.
3. Check closely for kinks in either copper tube or in plastic tube, which could block the flow of water to ice maker. Remove kinks or replace kinked tube, as appropriate.
4. Remove lower rear cover from refrigerator and check electrical connections to water valve coil. The plugs must be tight on spade terminals of water valve coil. *Replace lower rear cover before returning refrigerator to normal use. Refrigerator will not operate properly with this cover removed.*

Moving Refrigerator into Place

Procedure

1. Electrical outlet.
 - a. Check to be sure you have a separate electrical circuit (103-126 volt, 15 amp, 60 cycle) with a grounded outlet.

WARNING

Electrical Grounding Instructions—This appliance is equipped with a three-prong (grounding) plug for your protection against possible shock hazards. Where a two-prong wall receptacle is encountered, it is the personal responsibility and obligation of the customer to contact a qualified electrician and have it replaced with a properly grounded three-prong wall receptacle in accordance with the National Electrical Code (see figure).

Unit is designed to operate on a separate 103 to 126 volt, 15 amp., 60 cycle line.

DO NOT UNDER ANY CIRCUMSTANCES CUT OR REMOVE THE ROUND GROUNDING PRONG FROM THE PLUG. THE UNIT MUST BE GROUNDED AT ALL TIMES. DO NOT REMOVE WARNING TAG FROM THE SERVICE CORD.

WARNING

**DO NOT USE A TWO-PRONG ADAPTER.
DO NOT USE AN EXTENSION CORD.**

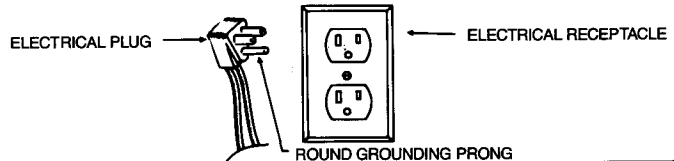

20

2. Protect soft vinyl or other flooring with cardboard, rugs or other protective material.
3. Install on a solid floor.
 - a. The floor must be able to support up to 800 lbs.
 - b. If floor is uneven, place a thin metal plate under one of rear wheels in order to level refrigerator side-to-side. A slight tilt to rear assures doors will remain closed.
4. Please refer to leveling refrigerator, page 21 to level refrigerator.
5. Plug refrigerator into electrical outlet.
6. Roll into place.
7. Remove tape and packing material.

Leveling Refrigerator

Recommended Tools

- 18-36" level
- 3/8" hex head nut driver
- Pliers

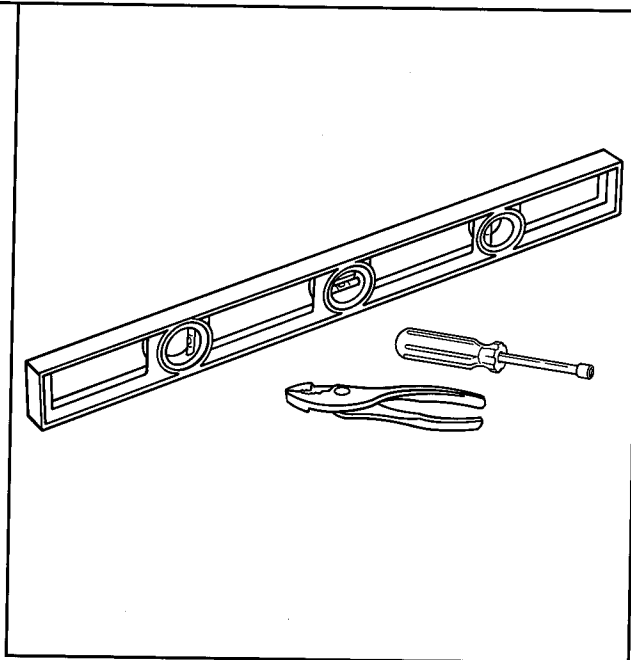

Figure 31

Procedure

1. Level refrigerator. Refrigerator must be level from side-to-side. Don't guess — use a level. Refrigerator should tilt slightly backward (no more than 1/4") to allow doors to close by themselves from an open position.

a. To level refrigerator, first place level side-to-side at top front of refrigerator.

b. Remove grille at bottom front of refrigerator.

c. Adjust leveling wheels (or leveling feet), depending on model.

d. Leveling legs (shipped taped to a shelf, inside refrigerator). Thread screw-type end into holes at bottom front of refrigerator. (Some models)

e. To raise cabinet, unscrew (↺) leveling legs. See Figure 32.

f. All four corners of refrigerator should be firmly in contact with the floor.

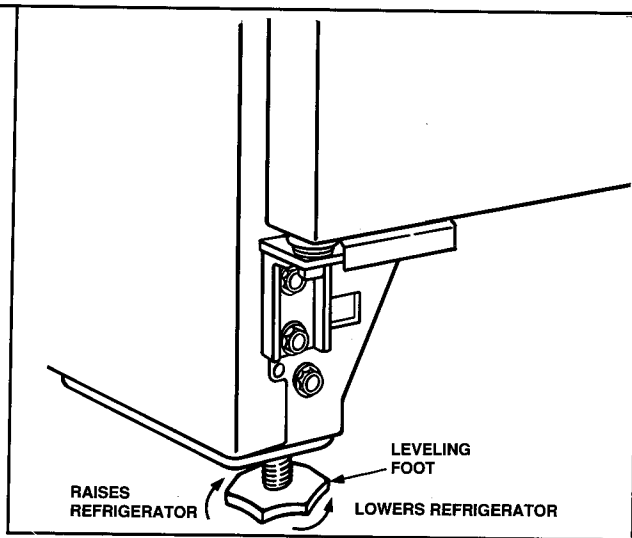

Figure 32

- g. Leveling wheels. To raise cabinet, rotate leveling screw in front of roller clockwise (↻) using the 3/8" hex nut driver. See Figure 33.
- h. Using level (front to back) raise wheels until front of cabinet is 1/4" higher than rear of cabinet. Doors should close slowly by themselves when opened 45°.
- i. All wheels should be firmly in contact with floor.

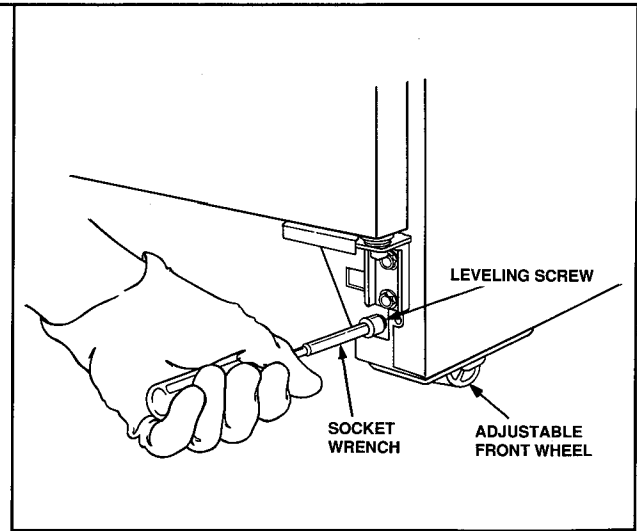

Figure 33

2. Defrost drain pan.

- a. Check to be sure defrost drain pan is in place underneath defrost water drain tube (left side, behind grille, under refrigerator). Front of pan is marked. Make sure it is pushed all the way back - and held securely in place on glide supports on either side of refrigerator cabinet. The pan will rattle if not properly placed on glides.

3. Toe grille.

- a. Replace grille at bottom front of refrigerator.

Reversing Refrigerator Doors

Recommended Tools

- Tightly fitted gloves
- 5/16" hex nut driver
- 3/8" hex head socket and ratchet
- Straight edge screwdriver
- Phillips screwdriver
- Strapping tape

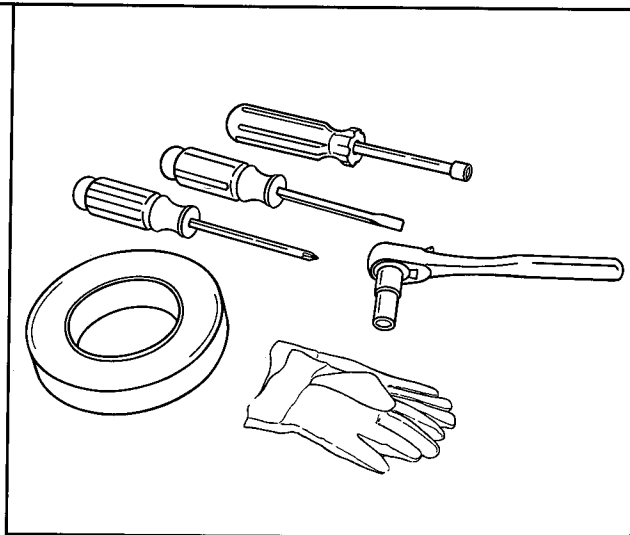

Figure 34

Amana top mount refrigerators are shipped with "right hand doors," hinged as shown in Figure 35.

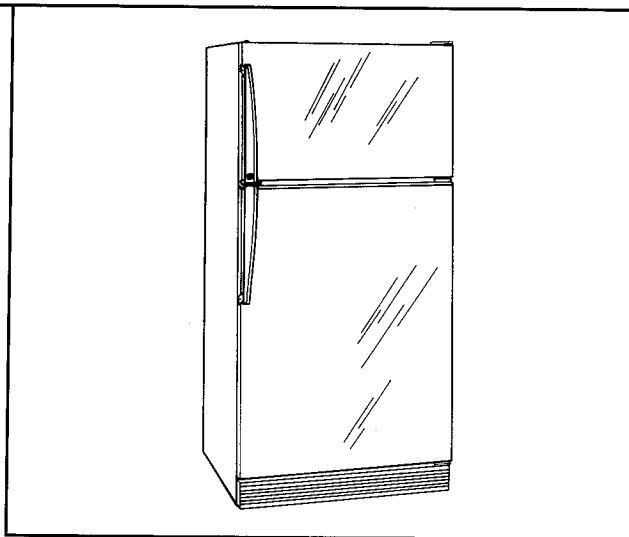

Figure 35

Refrigerators can be changed to "left hand doors," as shown in Figure 36, by completing following steps.

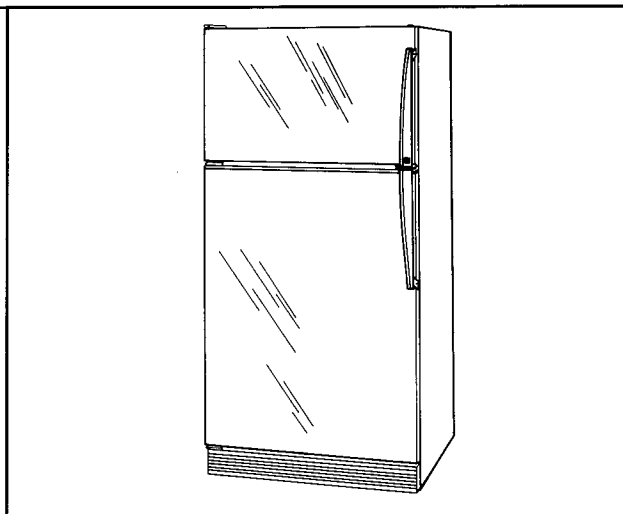

Figure 36

Procedure

To remove doors, follow steps 1-8 of door removal procedure, described on pages 5-7.

1. Transfer bottom hinge bracket to left side.
 - a. Place bottom hinge spacers between bottom hinge bracket and refrigerator on **bottom left side** of refrigerator.
 - b. Move bottom hinge bracket to **bottom left side** of cabinet.

- c. Tighten original 3/8" hex head screw with ratchet. See Figure 37.

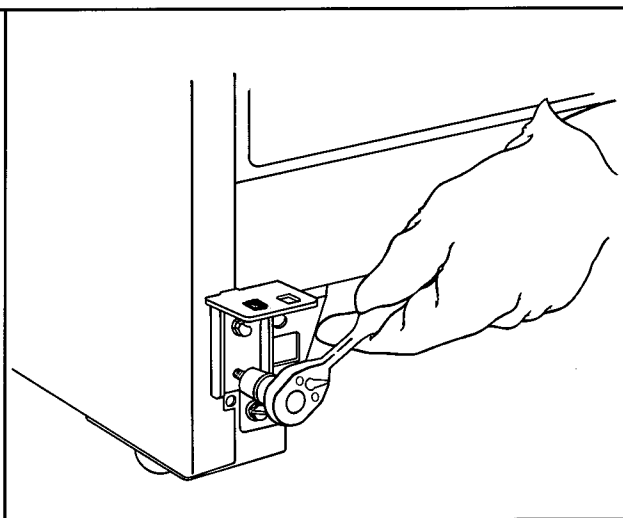

Figure 37

- d. Switch bottom hinge pin from right square hole in bracket to left square hole. See Figure 38. All hinge spacers and ring washers must be in place behind and on hinge pin.

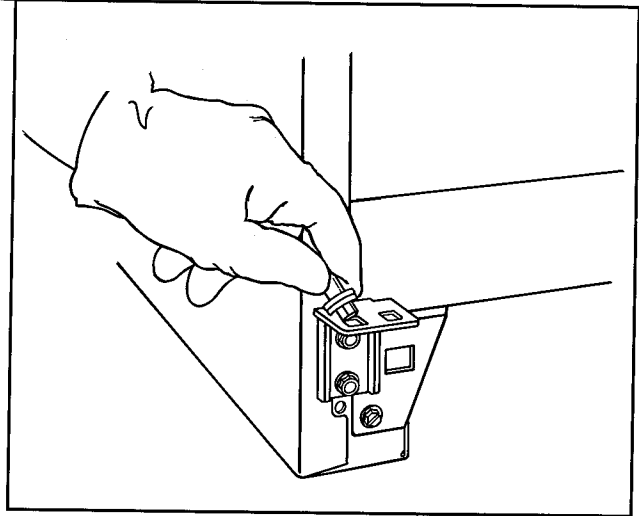

Figure 38

2. Transfer center hinge bracket to left.

- a. Remove two outermost 5/16" hex head screws from **center left side** of cabinet and insert them in holes previously occupied by Phillips head screws on **center right side**. See Figure 39.
- b. Loosen 5/16" hex head screw on **center left side** of cabinet.
- c. Turn hinge bracket with spacers over.

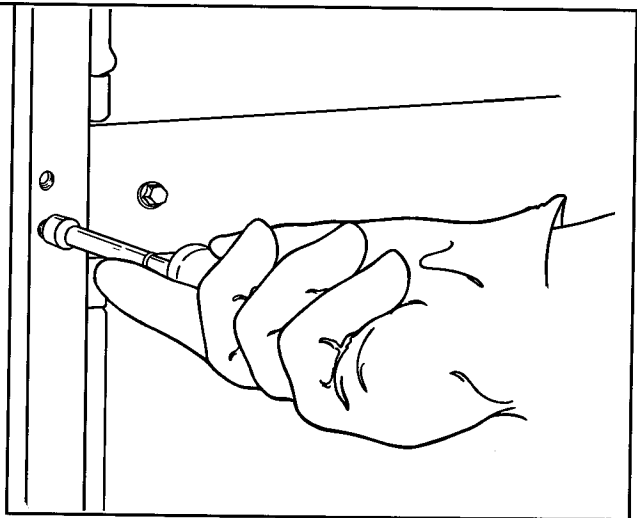

Figure 39

- d. Slide bracket and spacers under loosened hex head screw.

- e. Secure bracket with two Phillips head screws removed from other side. See Figure 40.

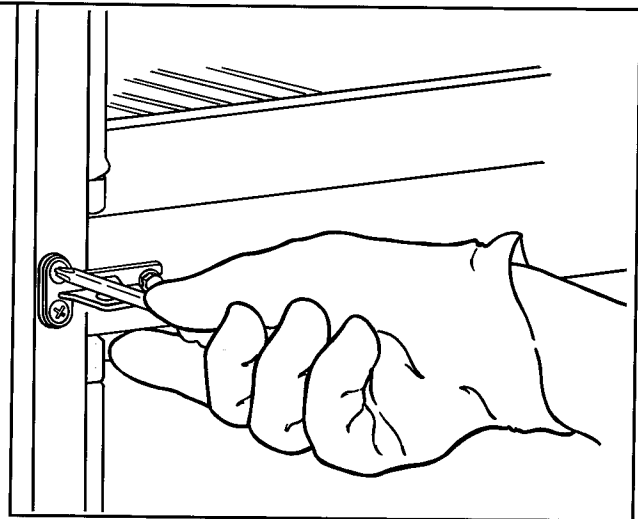

Figure 40

- f. Re-tighten hex head screw to secure bracket. See Figure 41.
3. Transfer top hinge to left.
- a. Remove plastic plug button at top left side of refrigerator. Place plug buttons on top right side of refrigerator, where 5/6" hex head screws were previously located.
- b. Place top plastic hinge plate spacer(s) on top of refrigerator and place top hinge plate on top of spacers on top left side of refrigerator. Do not tighten screws at this point. Some refrigerators may not have spacers.
- c. Position plastic top hinge plate rings on top hinge pin.

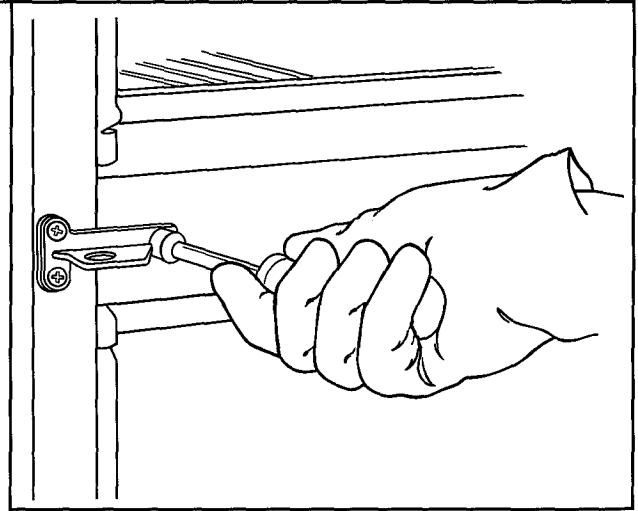

Figure 41

4. Remove handles from doors.

- a. Using a small taped straight edge screwdriver, remove screw cap located on each handle on outside of door by prying back end of screw cap up. See Figure 42.

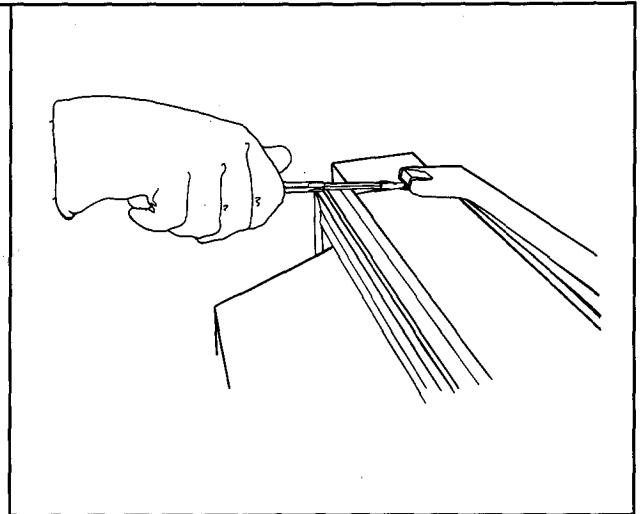

Figure 42

- b. Using a Phillips screwdriver, remove handle screws on top side of each handle on both doors. See Figure 43.

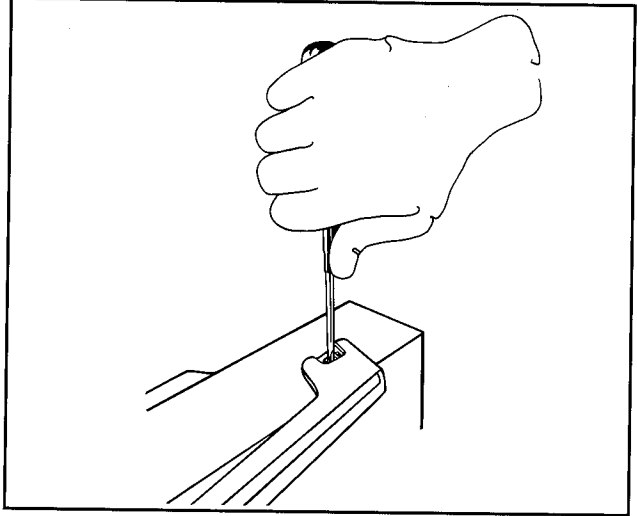

Figure 43

- c. Using a Phillips screwdriver, remove handle, remove handle screws on bottom side of each handle on both doors. See Figure 44.

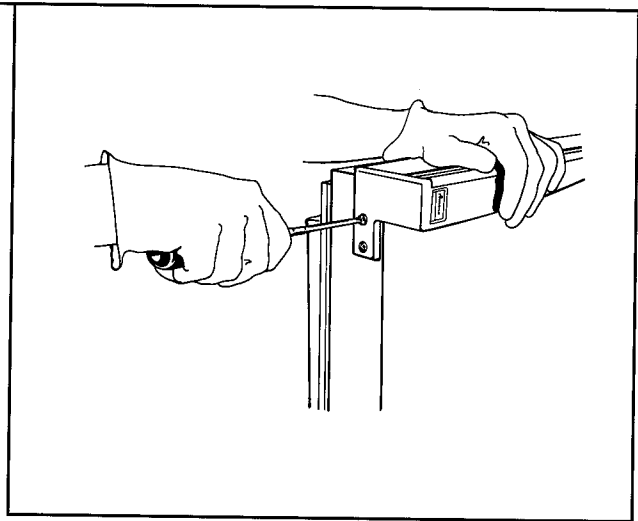

Figure 44

5. Move nameplate on handle to maintain upright position.

- a. Using a taped small screwdriver, pry off cover located behind nameplate. See Figure 45.
- b. Bend tabs behind nameplate up to remove nameplate.
- c. Rotate nameplate one half turn.

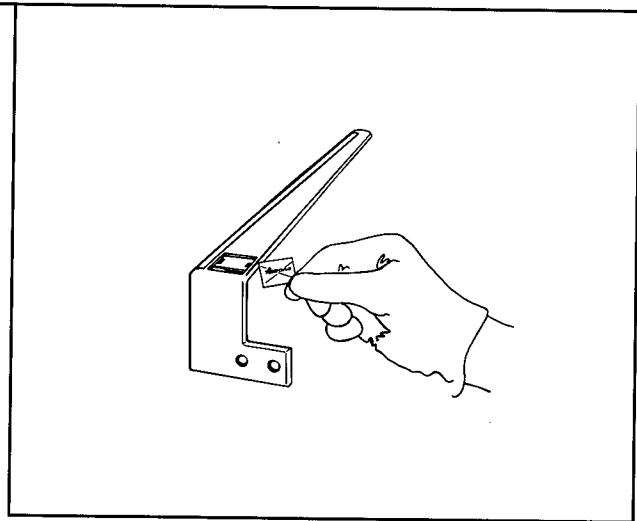

Figure 45

- d. Insert nameplate back into handle pad, then rebend tabs to lock nameplate in place. See Figure 46.

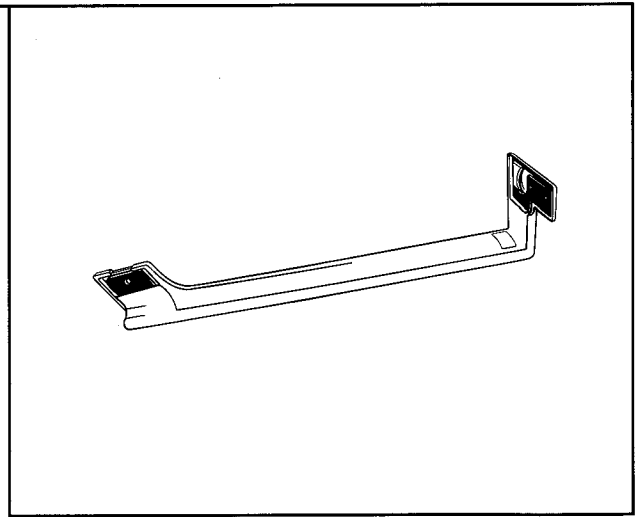

Figure 46

- e. Replace cover behind nameplate. See Figure 47.

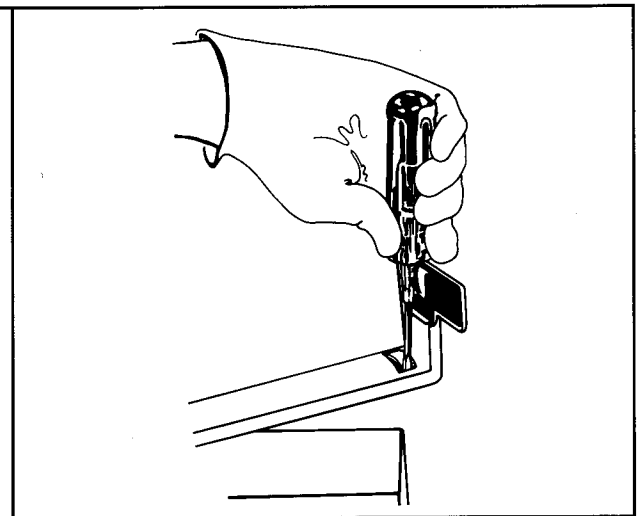

Figure 47

6. Using a Phillips screwdriver, transfer refrigerator and freezer door stops (featured on most models.)

a. Turn refrigerator door upside-down. Protect top trim by setting refrigerator door on a blanket or moving pad.

b. Transfer door stop from **right side to the left.**

c. Repeat this process on freezer door. See Figures 48 and 49.

7. Reverse handles. Former refrigerator door handle becomes freezer handle; former freezer door handle becomes refrigerator door handle.

a. Replace handles using original screws removed in Step 4. Screws with large heads go on side edge.

b. On refrigerator door, transfer any remaining screws from top right to top left as required.

c. On both doors, use plastic buttons from right side edges to fill corresponding screw holes on left side edges.

d. Replace screw cap on each handle.

⚠ CAUTION: To Avoid Risk of Personal Injury or Property Damage have (2) two people help rehang each door, one person to hold door while other secures hinge pin.

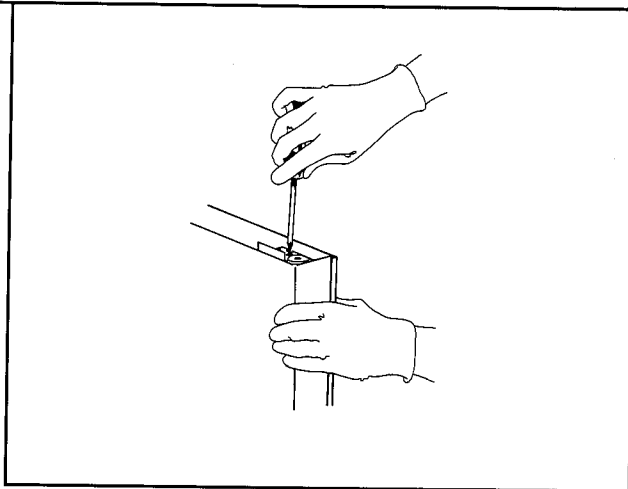

Figure 48

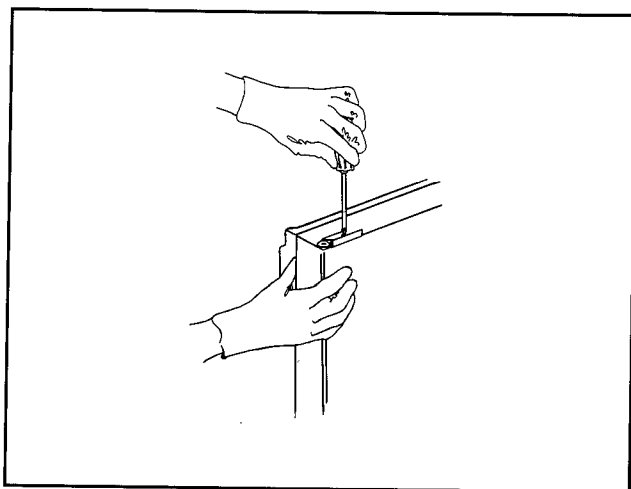

Figure 49

8. Rehang refrigerator and align door as described in steps 13-15 of door removal and replacement instructions, pages 10-12.

9. Rehang and align freezer door as described in steps 16-18 of door removal and replacement instructions, pages 11-12.

10. Install toe grille.

a. Slip grille insert out from left side and replace on right so that left-handed opening doors can operate with grille in place. See Figure 50.

b. Replace toe grille.

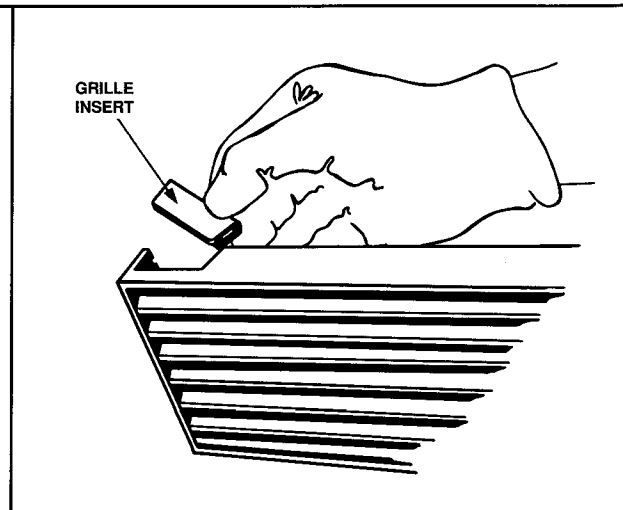

Figure 50

11. Transfer meat keeper and freezer ice service rack (some models). Transfer from left side of refrigerator to right side.

a. On refrigerated meat keeper refrigerators, pull plastic cap from air inlet port in back wall of refrigerator. See Figure 51.

b. Use a screwdriver with end taped to prevent scratching liner.

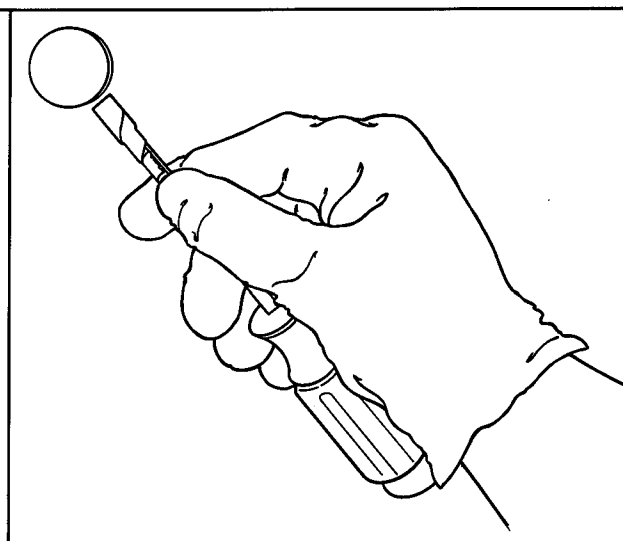

Figure 51

- c. Move meat storage shelf to a new position. See Figure 52.
- d. To ensure proper alignment, only insert the upper hooks of shelf into 1-3rd slots from the top. Food may freeze if refrigerated meat keeper is installed lower, leaving the air duct hole in the rear wall exposed.
- e. On refrigerated meat keeper refrigerators, plug previous inlet opening with plastic cap removed from other opening to ensure proper operation of meat keeper and refrigerated compartment, otherwise food will freeze on shelf under unplugged hole.

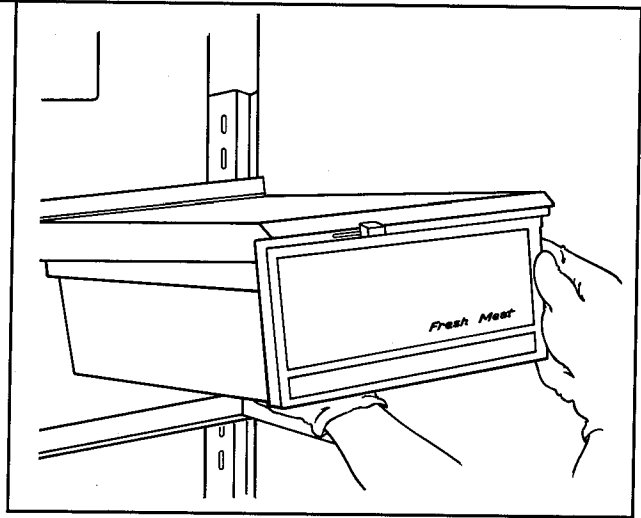

Figure 52

12. Refer back to leveling section on pages 21 and 22.

Setting the Controls

- 1. Locate refrigerator and freezer controls at inside back of refrigerator section. See Figure 53.
 - a. When the freezer control is set to "OFF", neither refrigerator or freezer will cool.
 - b. Set both controls to "4".

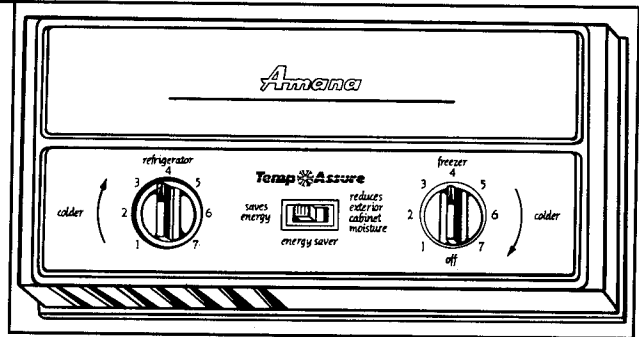

Figure 53

"Energy Saver Control"

- 1. Set this control in the "reduces exterior cabinet moisture," position for high humidity. See Figure 54.

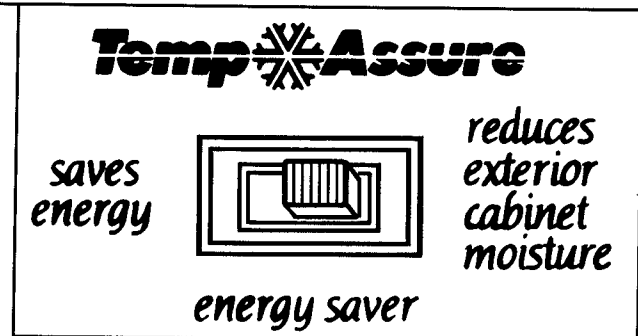

Figure 54

1/16" Decorator Door Panel Installation

Recommended Tools

- Tightly fitted gloves
- 5/16" hex nut driver
- Phillips screwdriver
- Flat screwdriver
- Putty knife
- Strapping tape
- Blanket or moving pad

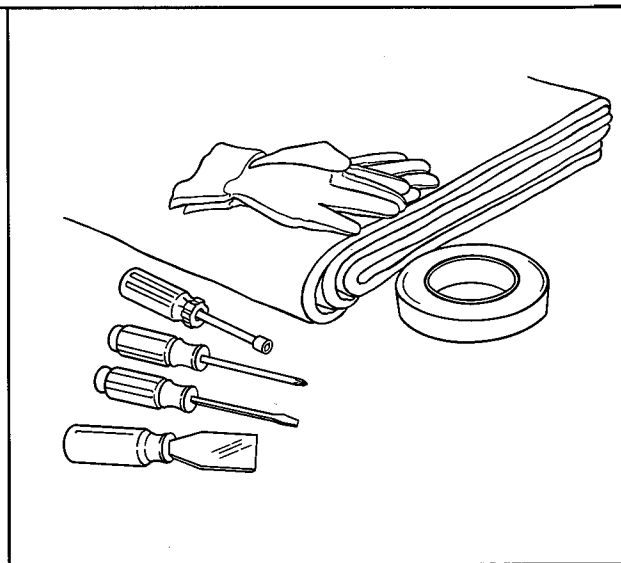

Figure 55

Procedure

1. Have custom made panels cut to size. See Figure 56.

2. Remove food from interior and door shelves and store in a cool place.

| | 18 Cu. Ft. | 20/22/23 Cu. Ft. |
|-------------------|---|---|
| Freezer Door | 31 ⁷ / ₈ " x 18 ⁷ / ₁₆ " 80.96 x 46.8 cm | 31 ⁷ / ₈ " x 19 ¹⁵ / ₁₆ " 80.96 x 50.64 cm |
| Refrigerator Door | 31 ⁷ / ₈ " x 40 ⁵ / ₁₆ " 80.96 x 102.93 cm | 31 ⁷ / ₈ " x 41 ⁵ / ₁₆ " 80.96 x 104.93 cm |

Figure 56

3.

CAUTION: To Avoid Personal Injury Or Property Damage from falling doors during removal and installation of doors: Temporarily tape both doors shut with strapping tape on top right and left corners of each door. See Figure 57.

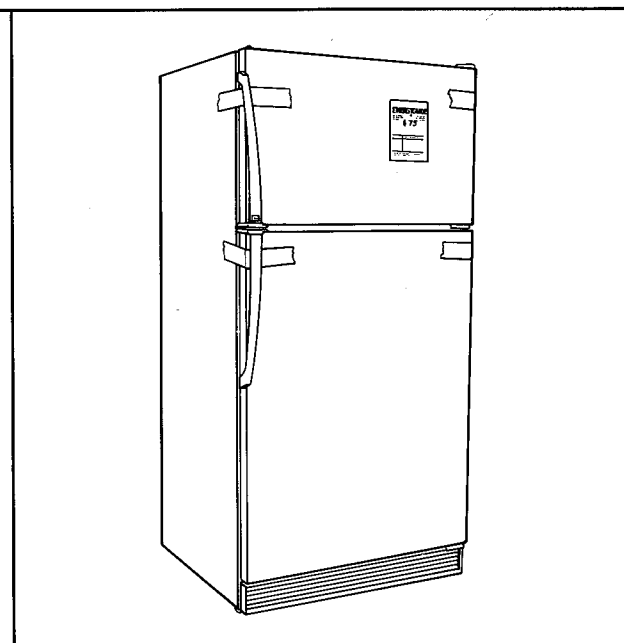

Figure 57

4. Remove top hinge cover.
 - a. Lift back of hinge cover about 1/4".
 - b. Slide hinge cover toward front and off hinge. See Figure 58.
 - c. Trace around the outside of hinge with a pencil. This allows easier aligning when reassembling.

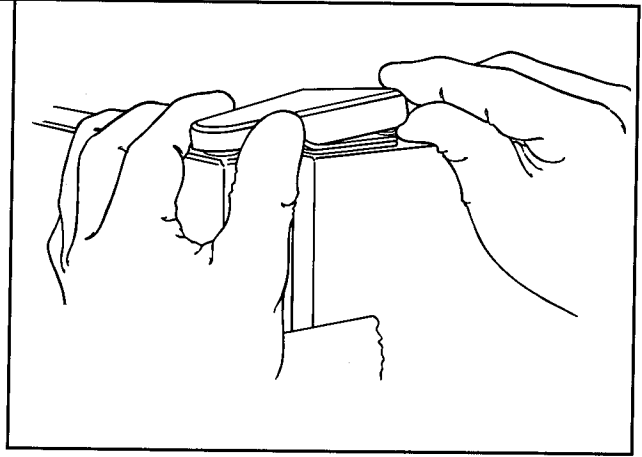

Figure 58

5. Free top hinge of freezer door.
 - a. Loosen the three 5/16" hex head screws with a 5/16" hex nut driver. See Figure 59.
 - b. Pull hinge upward to release freezer door.

⚠ CAUTION: To Avoid Risk of Personal Injury or Property Damage have (2) two people help remove each door, one person to hold door while the other removes strapping tape.

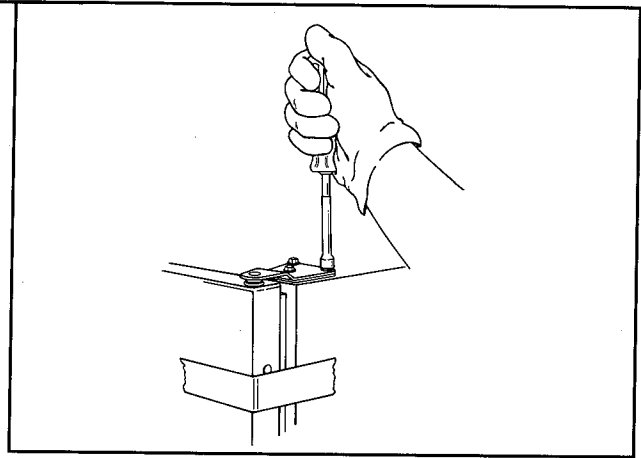

Figure 59

⚠ CAUTION: To Avoid Personal Injury or Property Damage: Do NOT allow door to drop to floor; to do so could damage door.

- c. Save plastic top hinge plate spacer(s), if used, and all unattached plastic hinge spacer ring(s) from underneath top hinge plate pin and use in Step 21. See Figure 60.

NOTE: Some refrigerators may not have spacer(s).

6. Remove freezer door.
 - a. Remove tape from freezer door.
 - b. Grasp freezer door securely and lift upward as you open it. This will free door from center hinge pin and you can set it aside.
 - c. Lay door down on blanket or moving pad.
 - d. At no time should door rest on its bottom edge after removal.

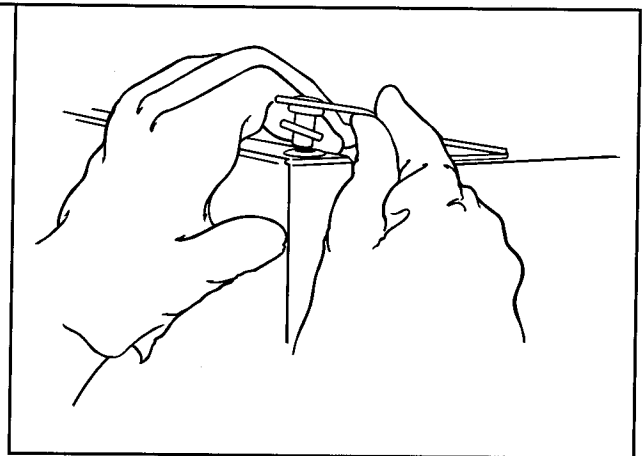

Figure 60

7. Remove top freezer trim.

- a. Carefully remove only topdoor trim with a putty knife. Do not remove peel-off tape from double back tape on trim. See Figure 61.

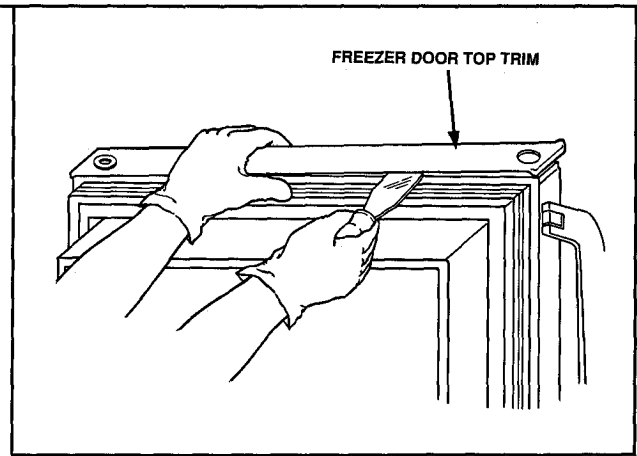

Figure 61

8. Practice putting decorator panel in place.

- a. Add four strips of masking tape to back side of decorator panel to prevent scratching door.

- b. Slide decorator panel in place between side trim. Do NOT remove peel-off paper from double back tape on trim. First practice installing top trim to avoid mistakes. See Figure 62.

9. Remove peel-off paper from double back tape and carefully install trim.

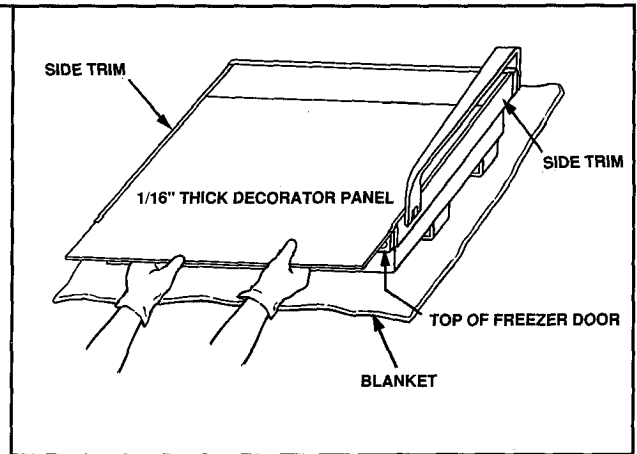

Figure 62

10. Remove center hinge pin.

- a. Save plastic center hinge spacer ring(s) from center hinge pin and use in Step 19. See Figure 63.

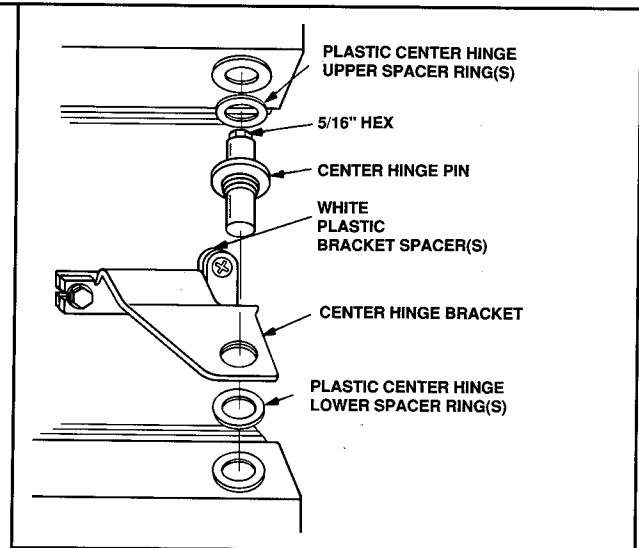

Figure 63

- b. Use a 5/16" nut driver to remove center hinge pin. See Figure 64.
- c. Pull hinge pin straight up to release it from refrigerator door.
- d. If plastic center hinge spacer rings from center hinge pin bracket and top of door were saved, then reuse in Step 19. See Figure 64.

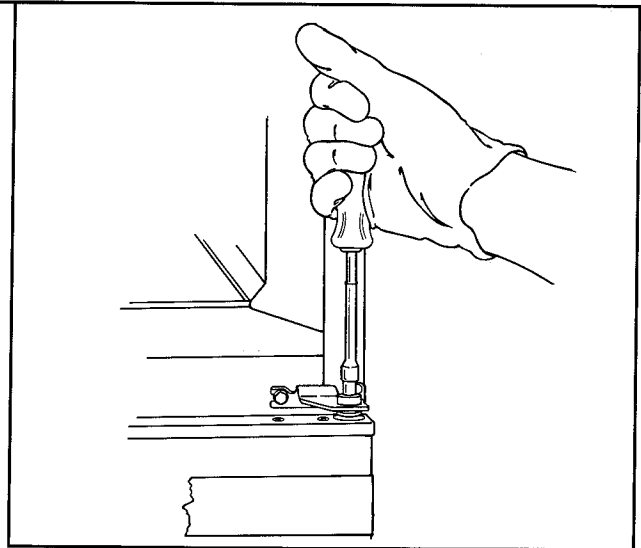

Figure 64

11. Remove refrigerator door.

- a. Remove tape from refrigerator door.
- b. Grasp refrigerator door securely and lift door upward as you open it. This will free refrigerator door from bottom hinge pin plate. See Figure 65.
- c. Lay door down on blanket or moving pad.

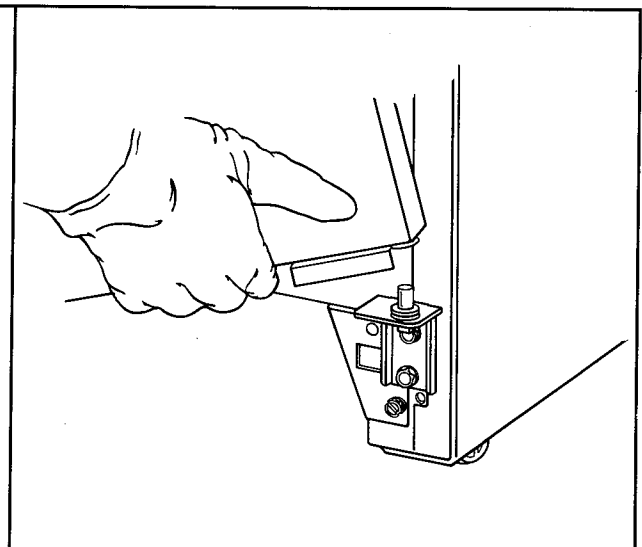

Figure 65

12. Remove refrigerator handle.

- a. Use flat screwdriver and pry up door handle side screw cover. See Figure 66.

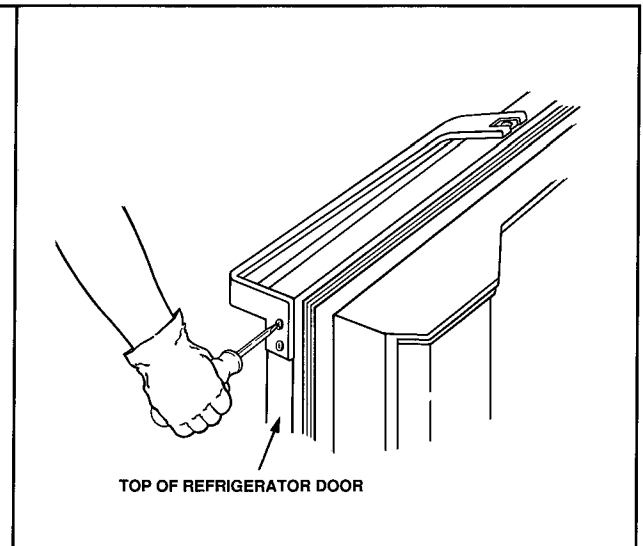

Figure 66

- b. Use phillips screwdriver to remove all door handle screws. See Figure 67.

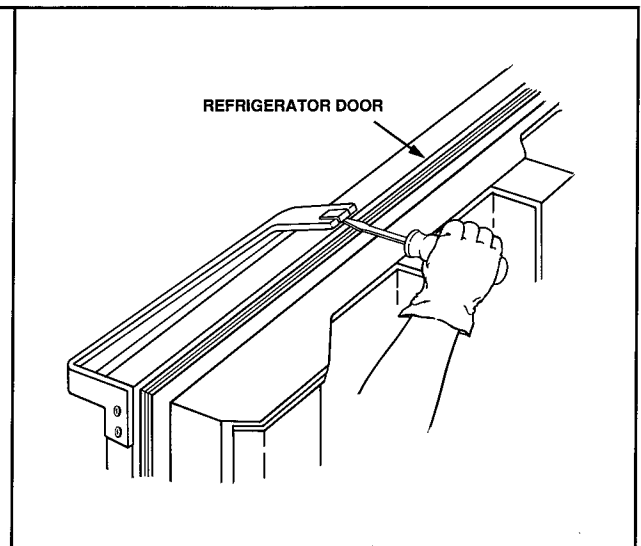

Figure 67

13. Remove top refrigerator trim.

- a. With a putty knife remove refrigerator door top trim. See Figure 68. Do not remove peel-off tape from double back tape on trim.

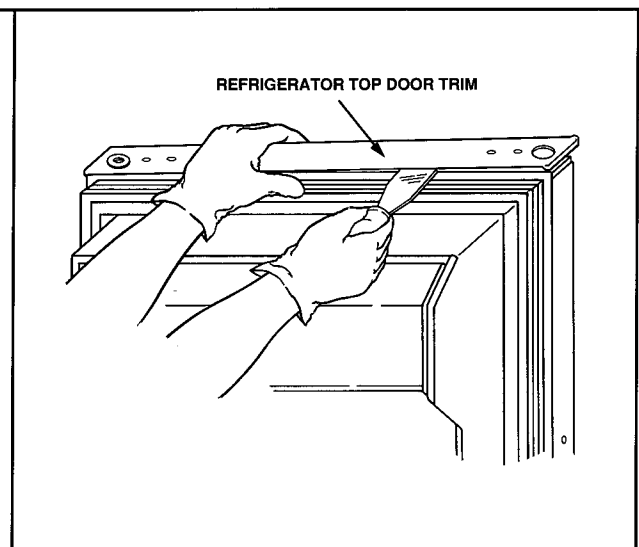

Figure 68

14. Practice putting decorator panel in place.
 - a. Add four strips of masking tape to back side of decorator panel to prevent scratching.

- b. Slide decorator panel in place between side trims. Do not remove peel-off paper from double back tape on trim. First practice installing top trim to avoid mistakes. See Figure 69.

15. Remove peel-off paper from double back tape and carefully install panel.

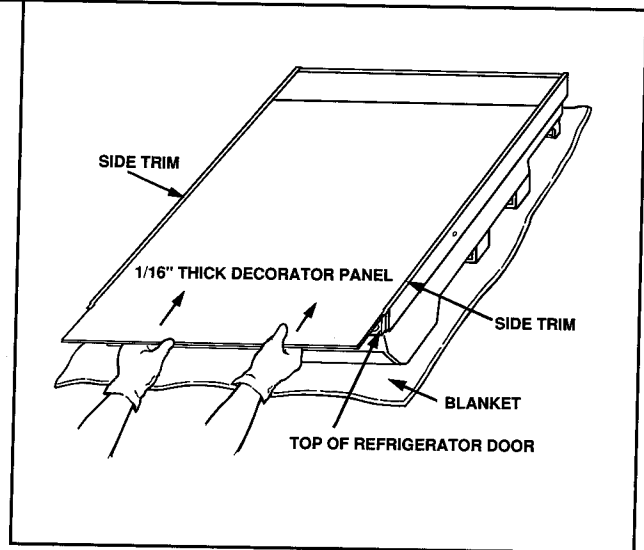

Figure 69

16. Place top hinge plate in position.
 - a. Place top plastic hinge plate spacer(s) on top of refrigerator.

- b. Place top hinge plate on top of spacers on top right side of refrigerator. See Figure 70.

- c. Turn top two screws closest to back of hinge. Leave front screw out.

⚠ CAUTION: To Avoid Risk of Personal Injury or Property Damage have (2) two people help rehang each door, one person to hold door while other secures hinge pin.

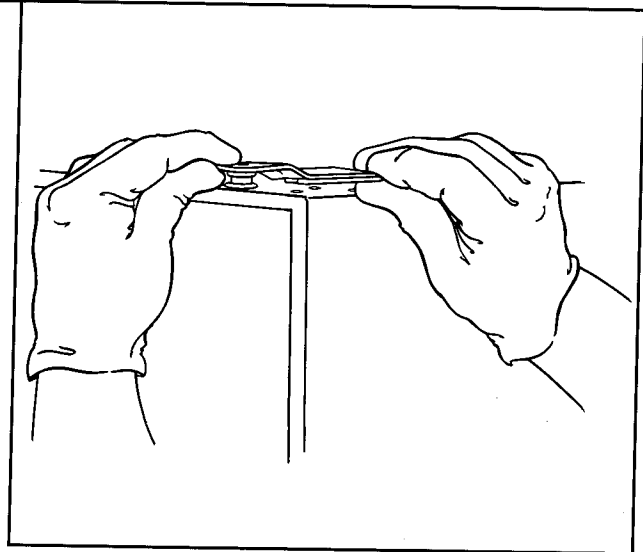

Figure 70

17. Install refrigerator door handle
 - a. Secure with original screws.
 - b. Snap handle side cover in place.

18. Rehang refrigerator door.

NOTE: All shims and spacer rings must be in place on lower hinge pin assembly before hanging door.

- a. Place door on cabinet by fitting bottom right socket over pin on bottom hinge bracket. See Figure 71.

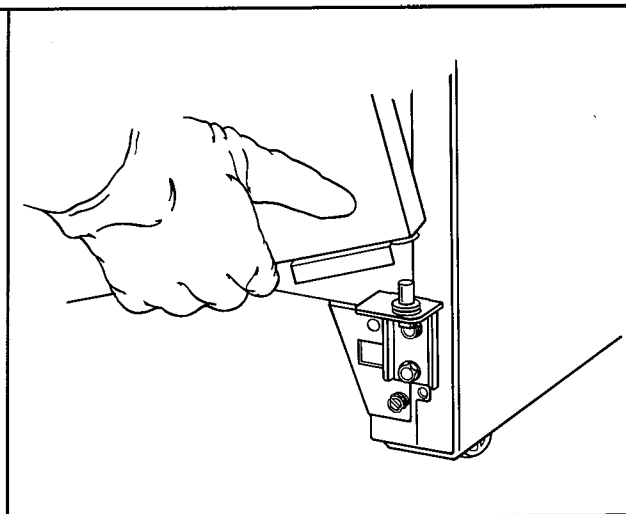

Figure 71

19. Center hinge assembly.

- a. Install all of the plastic center spacer ring(s) in the same position as in Steps 10. See Figure 72.

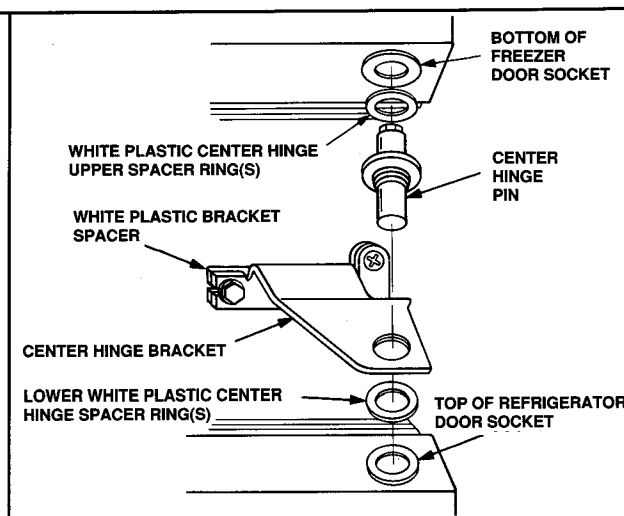

Figure 72

b. Holding door shut, reinstall center hinge pin so pin fits through bracket and into door socket. See Figure 73.

c. Secure hinge pin with 5/16" nut driver.

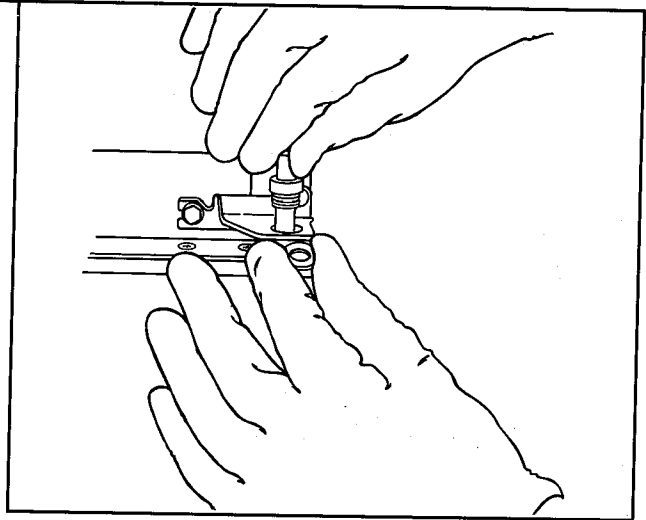

Figure 73

20. Check light switch operation.

a. Ease door slowly shut and visually observe if refrigerator doorliner engages on/off light switch to assure door is shutting off light when door is in closed position. See Figure 74.

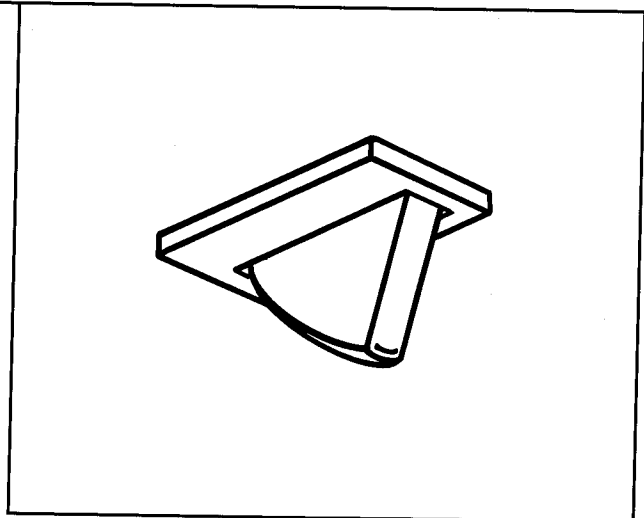

Figure 74

21. Rehang freezer door.

a. Position all plastic spacer rings from Step 5 and 10 on top hinge.

b. Place door on cabinet by fitting bottom right socket over pin on center hinge. See Figure 75.

c. Push door toward cabinet, lifting top hinge so pin fits into top right door socket.

d. Install third (front) top hinge screw.

e. Align hinge with outline of hinge traced in Step 4.

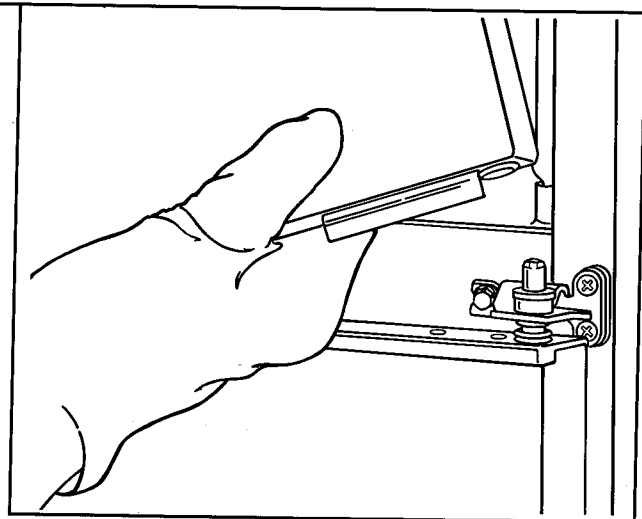

Figure 75

- f. Secure door by 'snugging' screws partially tight with 5/16" hex head screwdriver into top hinge. See Figure 76.

22. Align freezer door from side-to-side and top-to-bottom.

- a. Top hinge adjusts from front-to-back and side-to-side.
- b. Loosen top hinge screw and adjust so door is flush with side of refrigerator cabinet.

c. Handle side of door should be approximately 1/8" higher than top of refrigerator. The door will settle when loaded with food. Tighten top hinge screws.

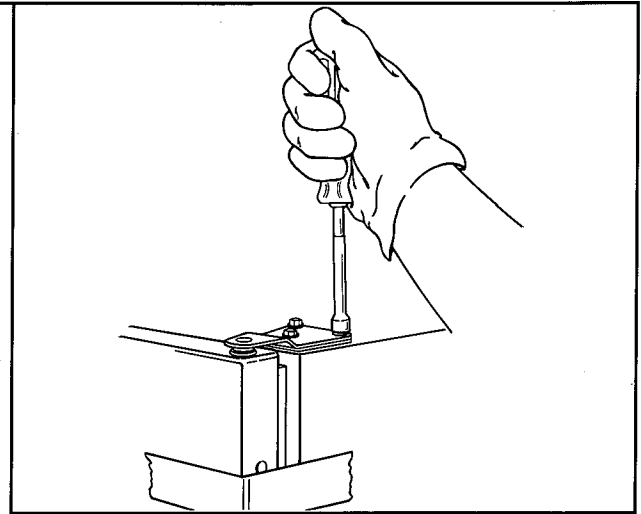

Figure 76

23. Check freezer light switch operation.
See Step 19.

24. Replace hinge covers.

- a. Position back lip of hinge cover over grooves.
- b. Snap back into place.

CONSUMER INFORMATION LINE
AMANA TOLL FREE
1-800-843-0304

Amana
A **Raytheon** Company