

# SEARS

## OWNER'S MANUAL

**MODEL  
NUMBERS:  
583.356500  
583.356820  
583.356830**

SERIAL NO. \_\_\_\_\_  
(owner - write in No.)

**CAUTION:  
Read Rules for  
Safe Operation  
and Instructions  
Carefully**

SAVE THIS MANUAL FOR  
FUTURE REFERENCE

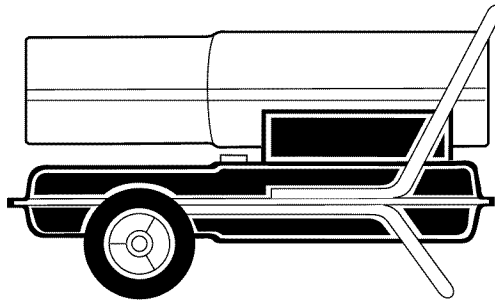
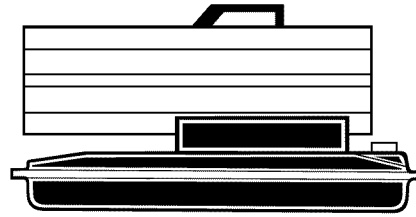

**Heater Sizes:  
35,000 55,000 and 110,000 Btu/Hr**

**Operation and Maintenance  
Instructions with Parts List**



# WARRANTY

For one year from the date of purchase, Sears will repair any defect in material or workmanship in this portable heater at no charge.

If the portable heater is used for commercial or rental purposes, this warranty applies for only thirty days from the date of purchase.

Warranty service is available by simply returning the heater to the nearest Sears Service Center. This warranty gives you the specific legal rights, and you may also have other rights which vary from state to state.

Sold by Sears, Roebuck and Co., 3333 Beverly Road, Hoffman Estates, IL 60179

# CONTENTS

SECTION	PAGE
Warranty .....	2
Safety Information .....	3
Product Identification .....	4
Unpacking .....	5
Assembly .....	5
Theory of Operation .....	6
Fuels .....	6
Ventilation .....	7
Operation .....	7
Storing, Transporting, or Shipping .....	8
Preventative Maintenance Schedule .....	8
Troubleshooting .....	9
Service Procedures .....	10
Upper Shell Removal .....	10
Fan .....	10
Air Output, Air Intake, and Lint Filters .....	10
Pump Pressure Adjustment .....	11
Fuel Filter .....	11
Spark Plug (35/55,000 Btu/Hr Models) .....	11
Spark Plug (110,000 Btu/Hr Model) .....	12
Nozzle (35/55,000 Btu/Hr Models) .....	12
Nozzle (110,000 Btu/Hr Model) .....	13
Pump Rotor .....	13
Specifications .....	14
Wiring Diagrams .....	14
Accessories .....	15
Maintenance Kits .....	15
Illustrated Parts Breakdowns and Parts Lists .....	16
Wheels and Handle Parts List (110,000 Btu/Hr Model) .....	22
How To Order Parts .....	Back Cover

## SAFETY INFORMATION

### WARNINGS

**IMPORTANT:** Read this owner's manual carefully and completely before trying to assemble, operate, or service this heater. Improper use of this heater can cause serious injury or death from burns, fire, explosion, electrical shock, and carbon monoxide poisoning.

### DANGER

**Carbon monoxide poisoning may lead to death!**

**Carbon Monoxide Poisoning:** Early signs of carbon monoxide poisoning resemble the flu, with headaches, dizziness, or nausea. If you have these signs, the heater may not be working properly. **Get fresh air at once!** Have heater serviced. Some people are more affected by carbon monoxide than others. These include pregnant women, people with heart or lung disease or anemia, those under the influence of alcohol, and those at high altitudes.

Make certain you read and understand all warnings. Keep this manual for reference. It is your guide to safe and proper operation of this heater.

- Use only kerosene or No. 1 fuel oil to avoid risk of fire or explosion. Never use gasoline, naphtha, paint thinners, alcohol, or other highly flammable fuels.
- Fueling
  - a) Personnel involved with fueling shall be qualified and thoroughly familiar with the manufacturer's instructions and applicable federal, state, and local regulations regarding the safe fueling of heating units.
  - b) Only the type of fuel specified on the heater's data plate shall be used.
  - c) All flame, including the pilot light, if any, shall be extinguished and the heater allowed to cool, prior to fueling.
  - d) During fueling, all fuel lines and fuel-line connections shall be inspected for leaks. Any leaks shall be repaired prior to returning the heater to service.
  - e) At no time shall more than one day's supply of heater fuel be stored inside a building in the vicinity of the heater. Bulk fuel storage shall be outside the structure.
  - f) All fuel storage shall be located a minimum of 25 feet from heaters, torches, welding equipment, and similar sources of ignition (exception: the fuel reservoir integral with the heater unit).
  - g) Whenever possible, fuel storage shall be confined to areas where floor penetrations do not permit fuel to drip onto or be ignited by a fire at lower elevation.
  - h) Fuel storage shall be in accordance with the federal, state, or local authority having jurisdiction.
- Never use heater where gasoline, paint thinner, or other highly flammable vapors are present.
- Follow all local ordinances and codes when using heater.
- Heaters used in the vicinity of tarpaulins, canvas, or similar enclosure materials shall be located a safe distance from such materials. The recommended minimum safe distance is 10 feet. It is further recommended that these enclosure materials be of a fire retardant nature. These enclosure materials shall be securely fastened to prevent them from igniting or from upsetting the heater due to wind action.
- Use only in well-vented areas. Provide at least three square feet of fresh, outside air for each 100,000 Btu/Hr of rating. This heater produces carbon monoxide, which is listed by the State of California as a reproductive toxin under Proposition 65.
- Use only in places free of flammable vapors or high dust content.

# SAFETY INFORMATION

- Use only with the electrical voltage and frequency specified on model plate.
- Use only a three-prong, grounded extension cord.
- Minimum heater clearances from combustibles:  
 Outlet: 8 Ft.    Sides: 4 Ft.    Top: 4 Ft.    Rear: 4 Ft.
- Locate heater on a stable and level surface while hot or running or a fire may occur.
- When moving or storing heater, keep heater in a level position or fuel spillage may occur.
- Keep children and animals away from heater.
- Unplug heater when not in use.
- When used with thermostat, heater may start anytime.
- Never use heater in living or sleeping areas.
- Never block air inlet (rear) or air outlet (front) of heater.
- Never move, handle, refuel, or service a hot, operating, or plugged-in heater.
- Never attach duct work to front or rear of heater.

# PRODUCT IDENTIFICATION

*Continued*

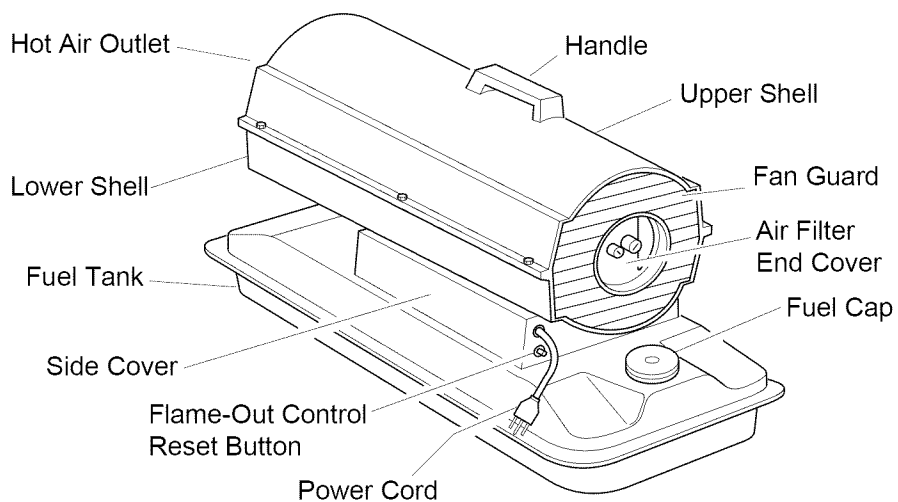

**Figure 1 - 35/55,000 Btu/Hr Models**

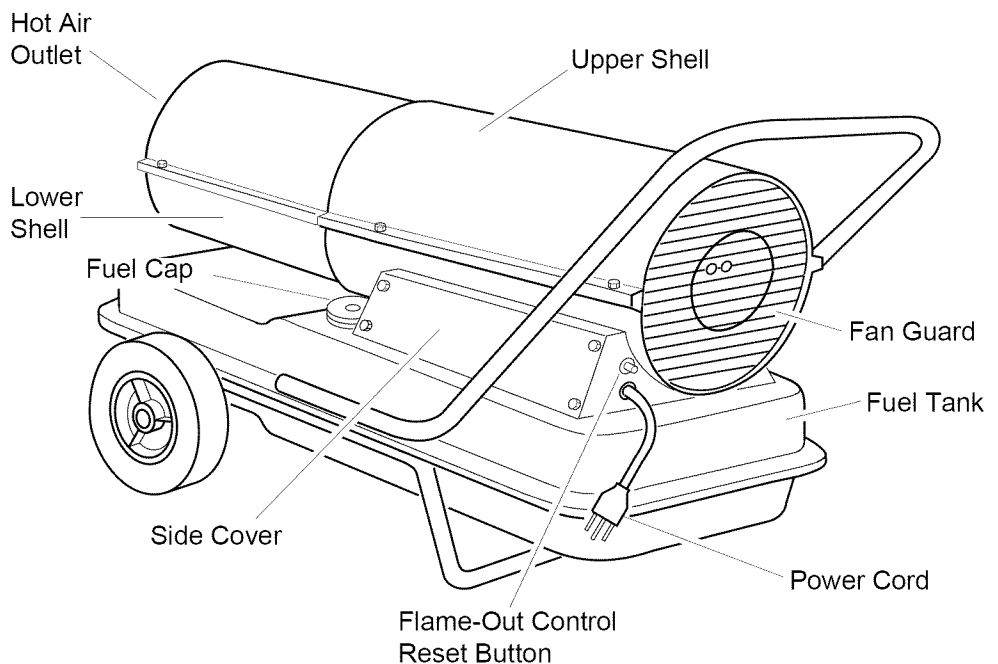

**Figure 2 - 110,000 Btu/Hr Model**

## UNPACKING

1. Remove all packing items applied to heater for shipment.
2. Remove all items from carton.
3. Check items for shipping damage. If heater is damaged, promptly inform dealer where you bought heater.

## ASSEMBLY

(For 110,000 Btu/Hr  
Model Only)

This model is furnished with wheels and a handle. Wheels, handle, and the mounting hardware are found in the shipping carton.

### Tools Needed

- Medium Phillips Screwdriver
- 3/8" Open or Adjustable Wrench
- Hammer

1. Slide axle through wheel support frame. Install wheels on axle.  
*IMPORTANT:* When installing wheels, point extended hub of wheels toward wheel support frame (see Figure 3).
2. Place cap nuts on axle ends. Gently tap with hammer to secure.
3. Place heater on wheel support frame. Make sure hot air outlet end (front) of heater is over wheels. Line up holes on fuel tank flange with holes on wheel support frame.
4. Place plastic tube caps onto open ends of handle.
5. Place handle on top of fuel tank flange. Make sure handle is over air inlet end (rear) of heater. Insert four screws through handle, fuel tank flange, and wheel support frame. Attach nut finger tight after each screw is inserted.
6. Insert remaining four screws through tank flange and wheel support frame. Attach nut finger tight after each screw is inserted.
7. After all screws are inserted, tighten nuts firmly.

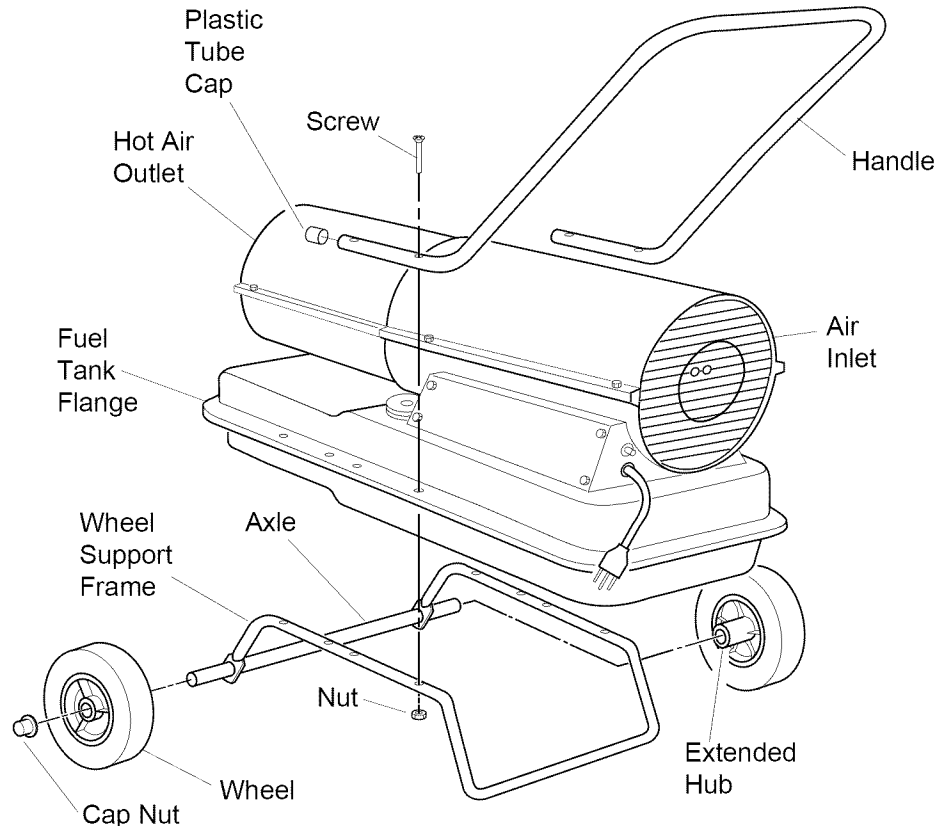

**Figure 3 - Wheel and Handle Assembly, 110,000 Btu/Hr Model Only**

# THEORY OF OPERATION

**The Fuel System:** The air pump forces air through the air line. The air is then pushed through the burner head nozzle. This air causes fuel to lift from the tank. A fine mist of fuel is sprayed into the combustion chamber.

**The Air System:** The motor turns the fan. The fan pushes air into and around the combustion chamber. This air is heated and provides a stream of clean, hot air.

**The Ignition System:** The electronic ignitor sends voltage to the spark plug. The spark plug ignites the fuel and air mixture.

**The Flame-Out Control System:** This system causes the heater to shut down if the flame goes out.

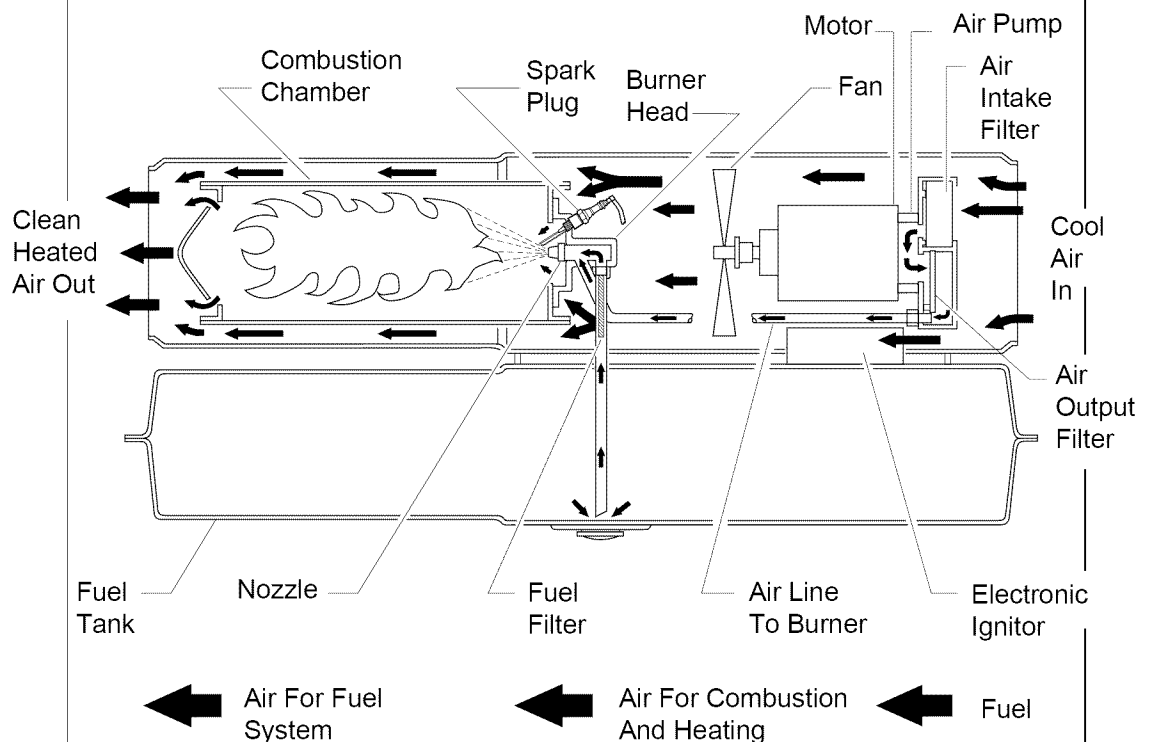

Figure 4 - Cross Section Operational View

# FUELS

## ⚠ WARNING

**Use only kerosene or No. 1 fuel oil to avoid risk of fire or explosion. Never use gasoline, naphtha, paint thinners, alcohol, or other highly flammable fuels.**

Do not use heavy fuels such as No. 2 fuel oil or No. 2 diesel. Using heavy fuels will result in:

- clogged fuel filter and nozzle
- carbon build-up on spark plug
- the need of non-toxic anti-icer in fuel during very cold weather

**IMPORTANT:** Use a KEROSENE ONLY storage container. Be sure storage container is clean. Foreign matter such as rust, dirt, or water will cause the flame-out control to shut down heater. Foreign matter may also require you to clean fuel system often.

## VENTILATION

### **⚠ WARNING**

**Follow the minimum fresh, outside air ventilation requirements. If proper fresh, outside air ventilation is not provided, carbon monoxide poisoning can occur. Provide proper fresh, outside air ventilation before running heater.**

Provide a fresh air opening of at least three square feet for each 100,000 Btu/Hr rating. Provide extra fresh air if more heaters are being used.

*Example:* A 110,000 Btu/Hr heater requires one of the following:

- a two-car garage door raised three inches
- a single-car garage door raised five inches
- two thirty-inch windows raised eight inches

## OPERATION

### **IMPORTANT**

Review and understand the warnings in the Safety Information Section. They are needed to safely operate this heater. Follow all local codes when using this heater.

### **To Start Heater**

1. Follow all ventilation and safety information.
2. Fill fuel tank with kerosene or No. 1 fuel oil.
3. Attach fuel cap.
4. Plug power cord of heater into three-prong, grounded extension cord. Extension cord must be at least six feet long.

### **Extension Cord Wire Size Requirements**

6 to 10 feet long, use 18 AWG rated cord

11 to 100 feet long, use 16 AWG rated cord

101 to 200 feet long, use 14 AWG rated cord

5. Plug extension cord into standard 120 volt/60 hertz, three-hole, grounded outlet. Heater will start when extension cord is plugged into outlet. If not, push in flame-out control reset button (see Figures 5 and 6).

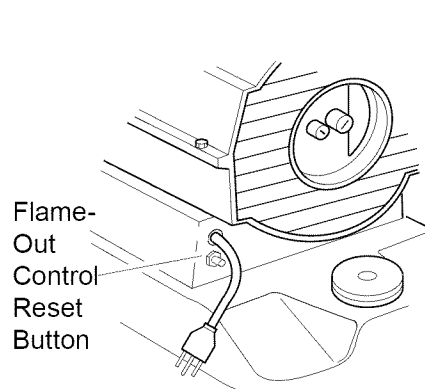

**Figure 5 - Flame-Out Control Reset Button, 35/55,000 Btu/Hr Models**

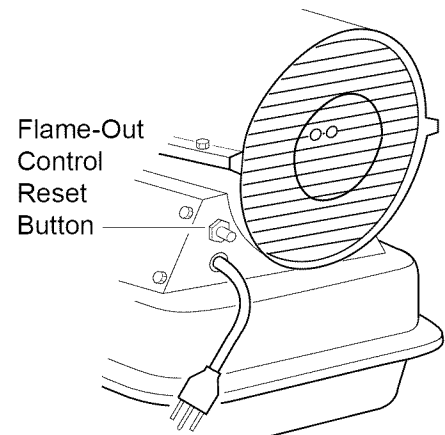

**Figure 6 - Flame-Out Control Reset Button, 110,000 Btu/Hr Model**

Continued

# OPERATION

*Continued*

## STORING, TRANSPORTING, OR SHIPPING

## PREVENTATIVE MAINTENANCE SCHEDULE

### To Stop Heater

1. Unplug extension cord from outlet.

### To Restart Heater

1. Wait 2 minutes after stopping heater.
2. Repeat steps under *To Start Heater*, page 7.

*Note:* If shipping, transport companies require fuel tanks to be empty.

1. Drain fuel tank.  
*Note:* Some models have drain plug on underside of fuel tank. If so, remove drain plug to drain all fuel. If heater does not have drain plug, drain fuel through fuel cap opening. Be sure all fuel is removed.
2. Replace drain plug if provided.
3. If any debris is noted in old fuel, add 1 or 2 quarts of clean kerosene to tank, stir, and drain again. This will prevent excess debris from clogging filters during future use.
4. Replace fuel cap or drain plug. Properly dispose of old and dirty fuel. Check with local automotive service stations that recycle oil.
5. If storing, store heater in dry place. Make sure storage place is free of dust and corrosive fumes.

**IMPORTANT:** Do not store kerosene over summer months for use during next heating season. Using old fuel could damage heater.

### WARNING

**Never service heater while it is plugged in, operating, or hot. Severe burns and electrical shock can occur.**

<u>Item</u>	<u>How Often</u>	<u>How To</u>
Fuel tank	Flush every 150-200 hours of operation or as needed.	See <i>Storing, Transporting, or Shipping</i> , above.
Air output and lint filters	Replace every 500 hours of operation or once a year.	See <i>Air Output, Air Intake, and Lint Filters</i> , page 10.
Air intake filter	Wash and dry with soap and water every 500 hours of operation or replace as needed.	See <i>Air Output, Air Intake, and Lint Filters</i> , page 10.
Fuel filter	Clean twice a heating season or replace as needed.	See <i>Fuel Filter</i> , page 11.
Spark plug	Clean and regap every 600 hours operation or replace as needed.	See <i>Spark Plug</i> , pages 11 and 12.
Fan blades	Clean each season or as needed.	See <i>Fan</i> , page 10.
Motor	Not required/permanently lubricated.	



# TROUBLE-SHOOTING

## WARNING

Never service heater while it is plugged in, operating, or hot. Severe burns and electrical shock can occur.

<u>OBSERVED FAULT</u>	<u>POSSIBLE CAUSE</u>	<u>REMEDY</u>
Heater ignites, but flame-out control shuts off heater after a short period of time.	Wrong pump pressure	See <i>Pump Pressure Adjustment</i> , page 11.
	Dirty air output, air intake and lint filters	See <i>Air Output, Air Intake, and Lint Filters</i> , page 10.
	Dirty fuel filter	See <i>Fuel Filter</i> , page 11.
	Dirt in nozzle	See <i>Nozzle</i> , pages 12 and 13.
	Dirty photocell lens	Clean photocell lens.
	Bad flame-out control	Replace flame-out control.

Heater will not ignite, but motor runs for a short period of time.	Wrong pump pressure	See <i>Pump Pressure Adjustment</i> , page 11.
	Carbon deposits on spark plug and/or improper gap	See <i>Spark Plug</i> , pages 11 and 12.
	Dirty fuel filter	See <i>Fuel Filter</i> , page 11.
	Dirt in nozzle	See <i>Nozzle</i> , page 12 and 13.
	Water in fuel tank	Drain and flush fuel tank with clean kerosene. See <i>Storing, Transporting, or Shipping</i> , above, page 8.

## WARNING: High Voltage!

Electronic ignitor not grounded	Make sure electronic ignitor mounting is tight.
Bad electronic ignitor	Replace electronic ignitor.

Motor does not start when heater is plugged in, fan rotates slowly or does not turn.	Flame-out control not reset	Press flame-out control reset button.
	Solid state relay not allowed to reset	Wait two minutes before trying to restart heater.
	Binding pump rotor	If fan is hard to turn, see <i>Pump Rotor</i> , page 13.

# SERVICE PROCEDURES

## Upper Shell Removal

1. Remove screws along each side of heater using 5/16" nut-driver. These screws attach upper and lower shells together.
2. Lift upper shell off.
3. Remove fan guard.

## Fan

**IMPORTANT:** Remove fan from motor shaft before removing motor from heater. The weight of the motor resting on the fan could damage the fan pitch.

1. Remove upper shell (see above).
2. Use 1/8" Allen wrench to loosen set-screw which holds fan to motor shaft.
3. Slip fan off motor shaft.
4. Clean fan using soft cloth moistened with kerosene or solvent.
5. Dry fan thoroughly.
6. Replace fan on motor shaft. Place fan hub flush with end of motor shaft (see Figure 9).
7. Place setscrew on flat of shaft. Tighten setscrew firmly (40-50 inch-pounds).
8. Replace fan guard and upper shell.

## Air Output, Air Intake, and Lint Filters

1. Remove upper shell (see above).
2. Remove filter end cover screws using 5/16" nut-driver.
3. Remove filter end cover.
4. Replace air output and lint filters.
5. Wash or replace air intake filter (see *Preventative Maintenance Schedule*, page 8).
6. Replace filter end cover.
7. Replace fan guard and upper shell.

**IMPORTANT:** Do not oil filters.

## ⚠ WARNING

Never service heater while it is plugged in, operating, or hot. Severe burns and electrical shock can occur.

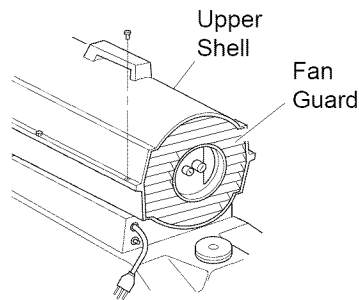

**Figure 7 - Upper Shell Removal, 35/55,000 Btu/Hr Models**

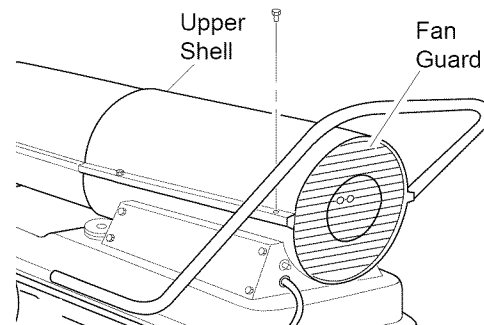

**Figure 8 - Upper Shell Removal, 110,000 Btu/Hr Model**

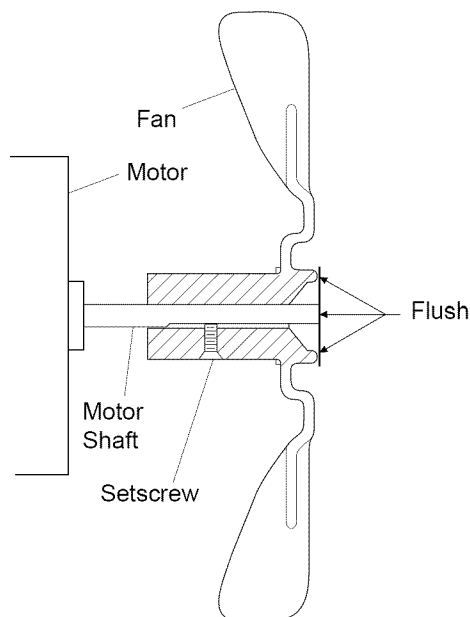

**Figure 9 - Fan Cross Section 35/55/110,000 Btu/Hr Models**

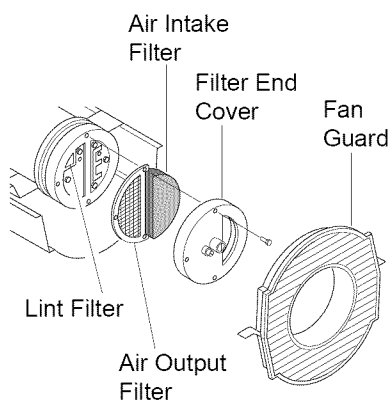

**Figure 10 - Air Output, Air Intake, and Lint Filters, 35/55,000 Btu/Hr Models**

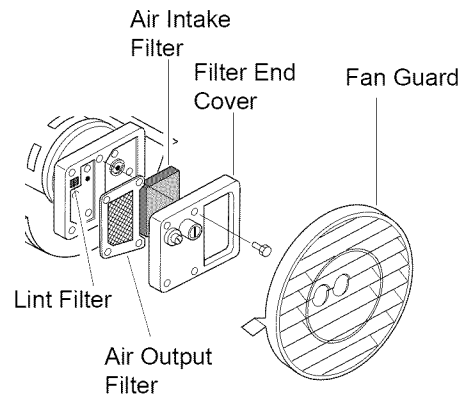

**Figure 11 - Air Output, Air Intake, and Lint Filters, 110,000 Btu/Hr Model**

## Pump Pressure Adjustment

1. Remove pressure gauge plug from filter end cover.
2. Install accessory pressure gauge (part number 583.35802).
3. Start heater (see *Operation*, page 7). Allow motor to reach full speed.
4. Adjust pressure. Turn relief valve to right to increase pressure. Turn relief valve to left to decrease pressure. See specifications at right for correct pressure for each model.
5. Remove pressure gauge. Replace pressure gauge plug in filter end cover.

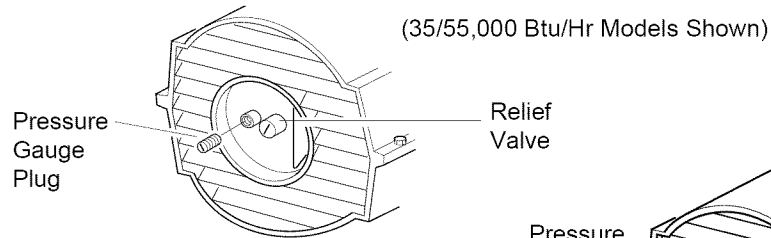

**Figure 12 - Pressure Gauge Plug Removal**

Model	Pump Pressure
35,000 Btu/Hr	3.0 PSI
55,000 Btu/Hr	3.4 PSI
110,000 Btu/Hr	4.5 PSI

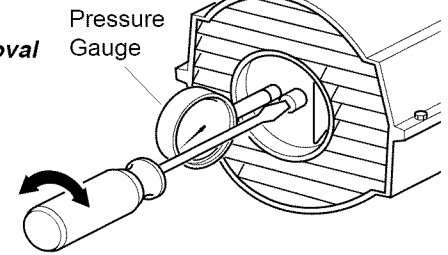

**Figure 13 - Adjusting Pump Pressure**

## Fuel Filter

1. Remove side cover screws using 5/16" nut-driver.
2. Remove side cover.
3. Pull upper fuel line off fuel filter neck.
4. Carefully pry bushing, fuel filter, and lower fuel line (110,000 Btu/Hr Model only) out of fuel tank.
5. Wash fuel filter with clean fuel and replace in tank.
6. Attach upper fuel line to fuel filter neck.
7. Replace side cover.

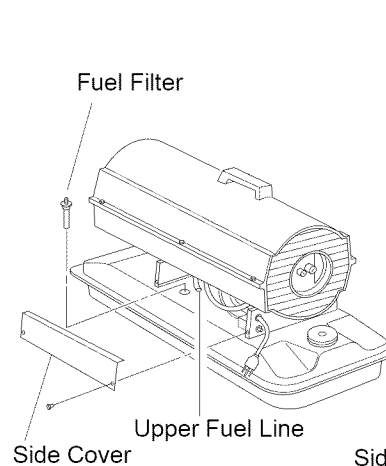

**Figure 14 - Fuel Filter Removal, 35/55,000 Btu/Hr Models**

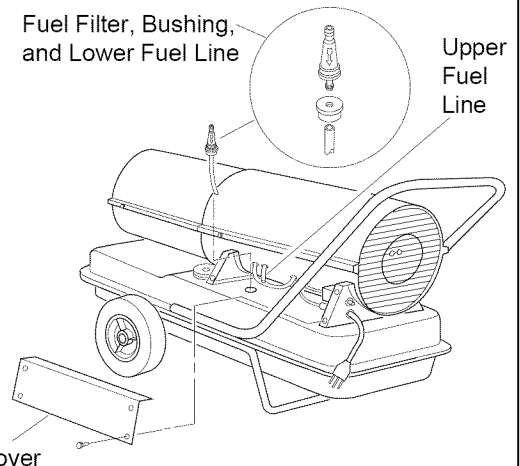
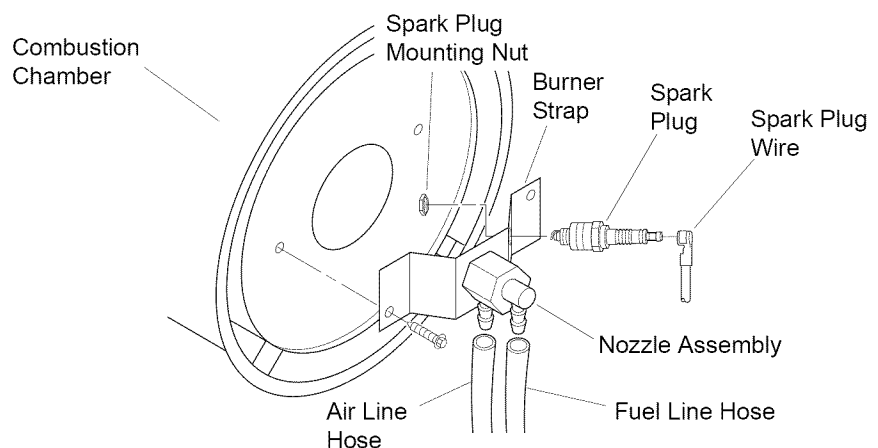

**Figure 15 - Fuel Filter Removal, 110,000 Btu/Hr Model**

## Spark Plug

(35/55,000 Btu/Hr Models)

1. Remove upper shell (see page 10).
2. Remove fan (see page 10).
3. Remove fuel and air line hoses from nozzle assembly.
4. Remove spark plug wire from spark plug.
5. Remove two screws using 5/16" nut-driver and remove burner strap.
6. Place hex-body of spark plug into vise and tighten.
7. Remove spark plug mounting nut using 11/16" open-end wrench.
8. Remove burner strap from spark plug.
9. Clean and regap spark plug electrodes to .055" gap.
10. Replace burner strap onto spark plug. Rotate burner strap to position spark plug electrodes (see Figure 18, page 12).



**Figure 16 - Spark Plug Removal, 35/55,000 Btu/Hr Models**

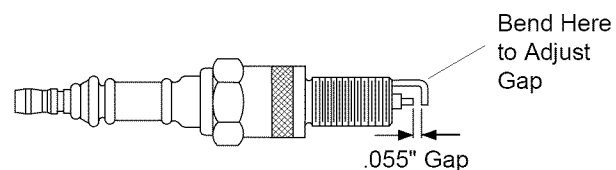

**Figure 17 - Spark Plug Gap, 35/55,000 Btu/Hr Models**

*Continued*

11. Tighten spark plug with spark plug mounting nut.
12. Release hex-body of spark plug from vise.
13. Replace burner strap onto combustion chamber.
14. Attach spark plug wire to spark plug.
15. Attach fuel and air line hoses to nozzle assembly.
16. Replace fan (see page 10).
17. Replace fan guard and upper shell.

## Spark Plug

### (110,000 Btu/Hr Model)

1. Remove upper shell (see page 10).
2. Remove fan (see page 10).
3. Remove spark plug wire from spark plug.
4. Remove spark plug from burner head using 13/16" open-end wrench.
5. Clean and regap spark plug electrodes to .075" gap
6. Install spark plug in burner head.
7. Attach spark plug wire to spark plug.
8. Replace fan (see page 10).
9. Replace fan guard and upper shell.

## Nozzle

### (35/55,000 Btu/Hr Models)

1. Remove upper shell (see page 10).
2. Remove fan (see page 10).
3. Remove fuel and air line hoses from nozzle assembly.
4. Turn nozzle assembly 1/4 turn to left and pull toward motor to remove.
5. Place plastic hex-body into vise and lightly tighten.
6. Carefully remove nozzle from the nozzle adapter using 5/8" socket wrench.
7. Blow compressed air thru face of nozzle. This will free any dirt in nozzle area.
8. Inspect nozzle sleeve for damage.
9. Replace nozzle into nozzle adapter until nozzle seats. Tighten 1/3 turn more using 5/8" socket wrench (40-45 inch-pounds).
10. Attach nozzle assembly to burner strap.
11. Attach fuel and airline hoses to nozzle assembly.
12. Replace fan (see page 10).
13. Replace fan guard and upper shell.

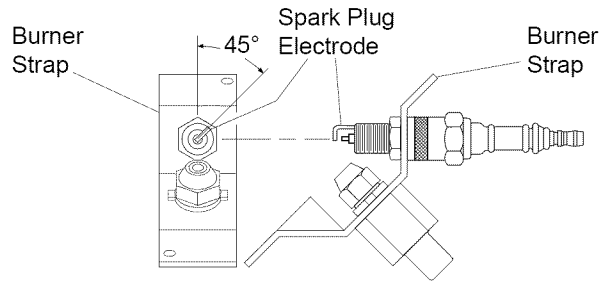

**Figure 18 - Spark Plug Rotation, 35/55,000 Btu/Hr Models Only**

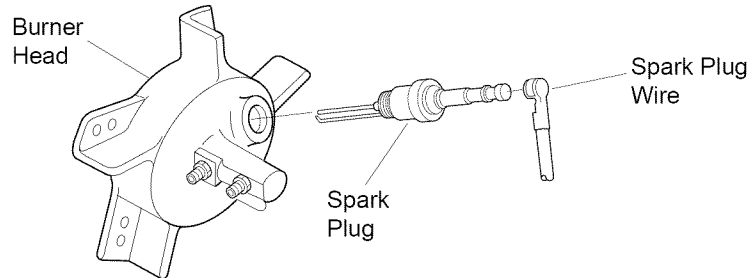

**Figure 19 - Spark Plug Removal, 110,000 Btu/Hr Model**

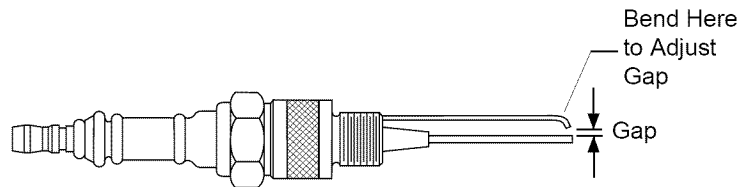

**Figure 20 - Spark Plug Gap, 110,000 Btu/Hr Model**

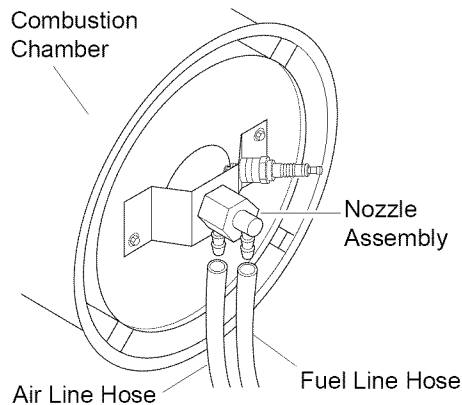

**Figure 21 - Removing Air and Fuel Line Hoses, 35/55,000 Btu/Hr Models**

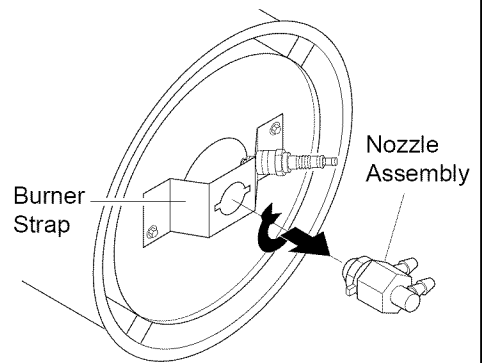

**Figure 22 - Removing Nozzle Assembly, 35/55,000 Btu/Hr Models**

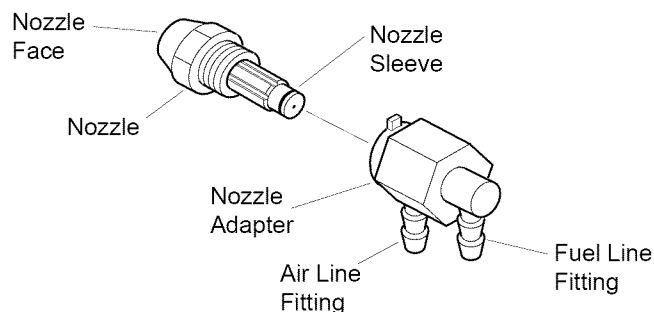

**Figure 23 - Nozzle and Nozzle Adapter, 35/55,000 Btu/Hr Models**

## Nozzle

### (110,000 Btu/Hr Model)

1. Remove upper shell (see page 10).
2. Remove fan (see page 10).
3. Remove fuel and air line hoses from burner head.
4. Remove spark plug cable from spark plug.
5. Remove spark plug from burner head using 13/16" open-end wrench.
6. Remove three screws using 5/16" nut-driver and remove burner head from combustion chamber.
7. Place burner head into vise and lightly tighten.
8. Carefully remove nozzle from burner head using 5/8" socket wrench (see Figure 25).
9. Blow compressed air thru face of nozzle. This will free any dirt in nozzle area.
10. Inspect nozzle sleeve for damage.
11. Replace nozzle into burner head and tighten firmly (80-110 inch-pounds).
12. Attach burner head to combustion chamber.
13. Install spark plug in burner head.
14. Attach spark plug cable to spark plug.
15. Attach fuel and airline hoses to burner head.
16. Replace fan (see page 10).
17. Replace fan guard and upper shell.

## Pump Rotor

### (Procedure if rotor is binding)

1. Remove upper shell (see page 10).
2. Remove filter end cover screws using 5/16" nut-driver.
3. Remove filter end cover and air filters.
4. Remove pump plate screws using 5/16" nut-driver.
5. Remove pump plate.
6. Remove rotor, insert, and blades.
7. Check for debris in pump. If debris is found, blow out with compressed air.
8. Install insert and rotor.
9. Check gap on rotor. Adjust to .003"/.004" if needed (see Figure 28, page 14).

**Note:** Rotate rotor one full turn to insure the gap is .003"/.004" at tightest position. Adjust if needed.

*Continued*

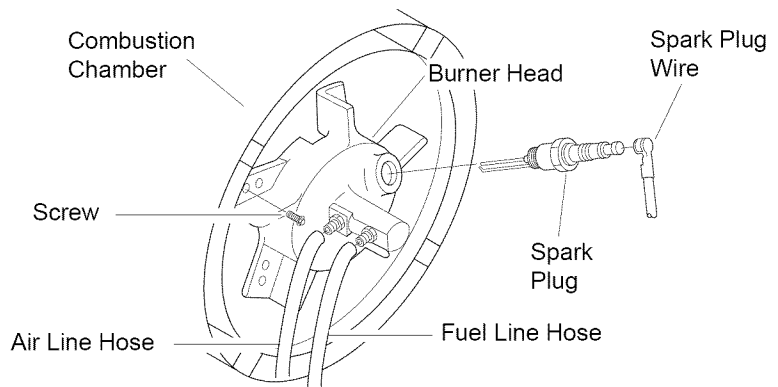

**Figure 24 - Removing Burner Head, 110,000 Btu/Hr Model**

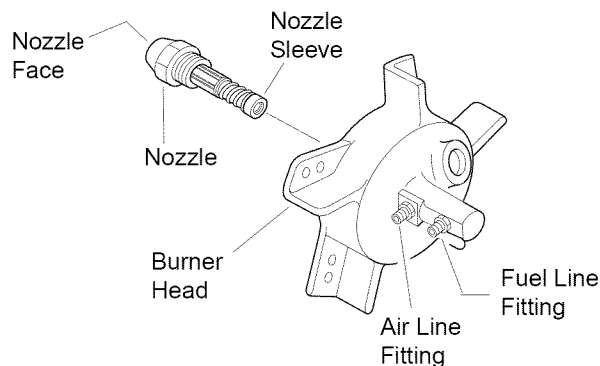

**Figure 25 - Removing Nozzle, 110,000 Btu/Hr Model**

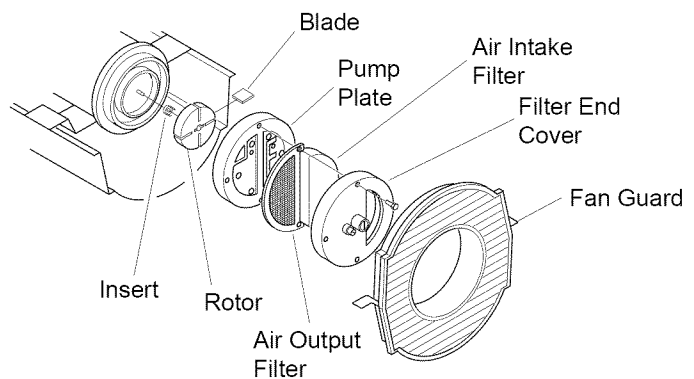

**Figure 26 - Rotor Location, 35/55,000 Btu/Hr Models**

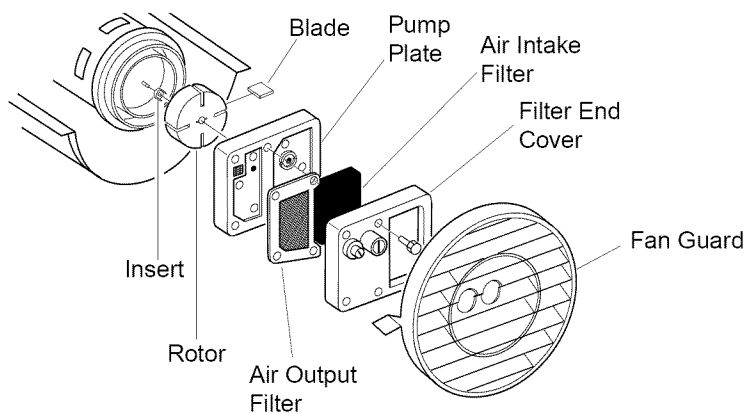

**Figure 27 - Rotor Location, 110,000 Btu/Hr Model**

**(Pump Rotor, continued)**

10. Install blades, pump plate, air filters, and filter end cover.
11. Replace fan guard and upper shell.
12. Adjust pump pressure (see page 11).

*Note:* If rotor is still binding, proceed as follows:

13. Perform steps 1 thru 6 (see page 13).
14. Place fine grade sandpaper (600 grit) on flat surface. Sand rotor lightly in “figure 8” motion four times (see Figure 29).
15. Reinstall insert and rotor.
16. Perform steps 10 thru 12 above.

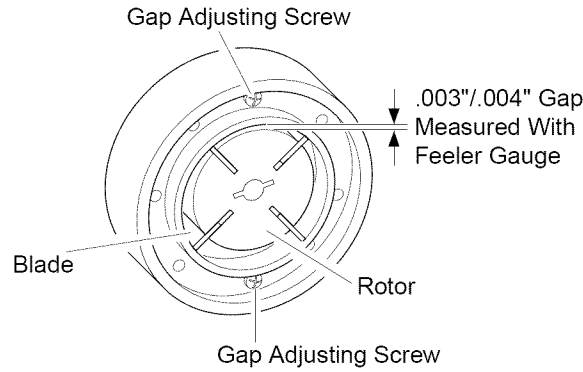

**Figure 28 - Gap Adjusting Screw Locations**

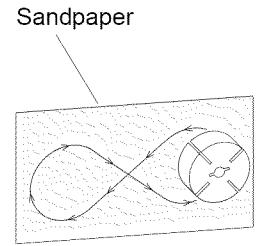
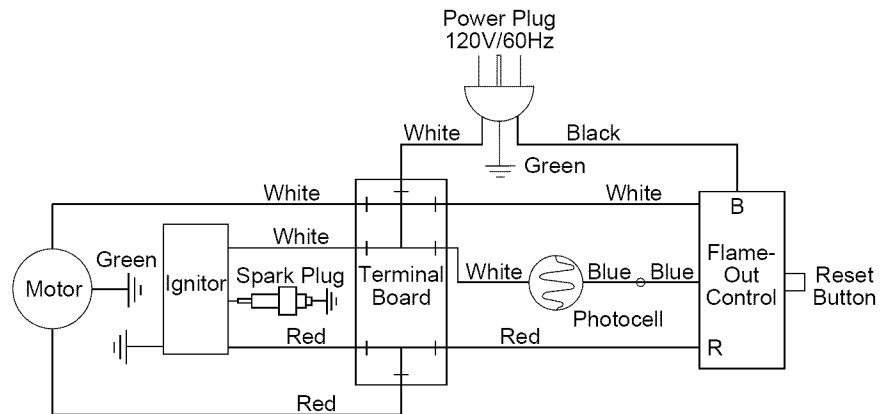

**Figure 29 - Sanding Rotor**

## SPECIFICATIONS

Output Rating (Btu/Hr.)	35,000	55,000	110,000
Fuel	Use Only Kerosene or No. 1 Fuel Oil		
Fuel Tank Capacity (U.S. Gal.)	3.0	5.0	9.0
Fuel Consumption (Gal. Per Hr.)	.26	.40	.82
Electric Requirements	120 V/60 Hz (Same All Models)		
Amperage (Normal Run)	2.0	2.0	4.5
Hot Air Output (CFM)	165	175	490

## WIRING DIAGRAMS



**Figure 30 - Wiring Diagram, 35/55,000 Btu/Hr Models**

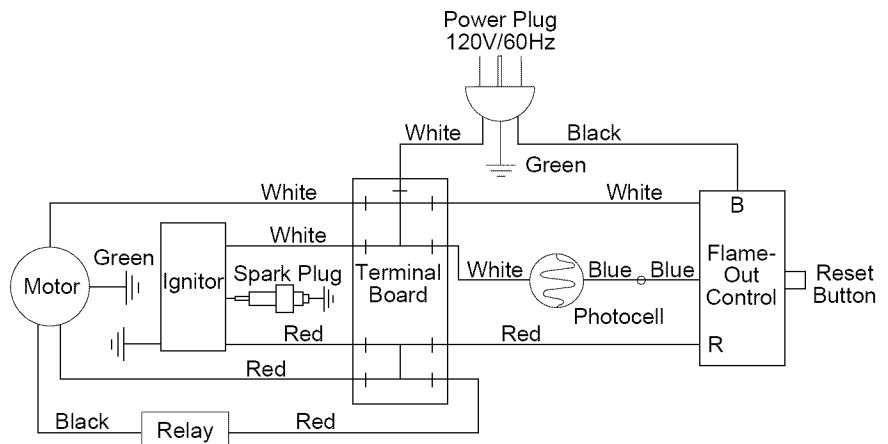

**Figure 31 - Wiring Diagram, 110,000 Btu/Hr Model**

## ACCESSORIES

Purchase these accessories from your local Sears store.

### AIR GAUGE KIT - 583.35802

For all models. Special tool to check pump pressure.

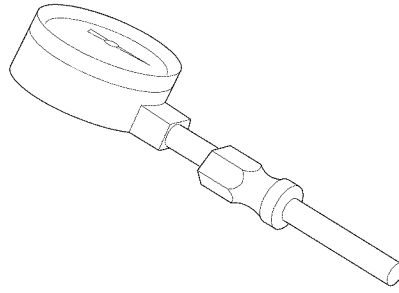

### STANDARD WHEELS AND HANDLE KIT - 583.35800

Makes heater even more portable and convenient. Easy to assemble. Fits 35/55,000 Btu/Hr models.

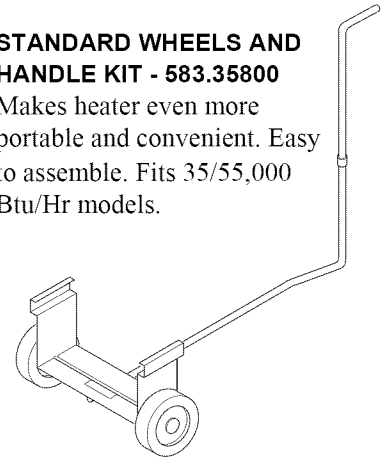

## MAINTENANCE KITS

Btu/Hr	35,000	55,000	110,000
Fuel Tank Filter Screen	HA2210	HA2210	HA2210
Rotor/Air Pump Kit	HA3004	HA3005	HA3004
Filter Kit	HA3014	HA3014	HA3017
Pump Kit	HA3020	HA3020	HA3020

# ILLUSTRATED PARTS BREAKDOWN

Sears Portable Heater  
Model 583.356500  
35,000 Btu/Hr

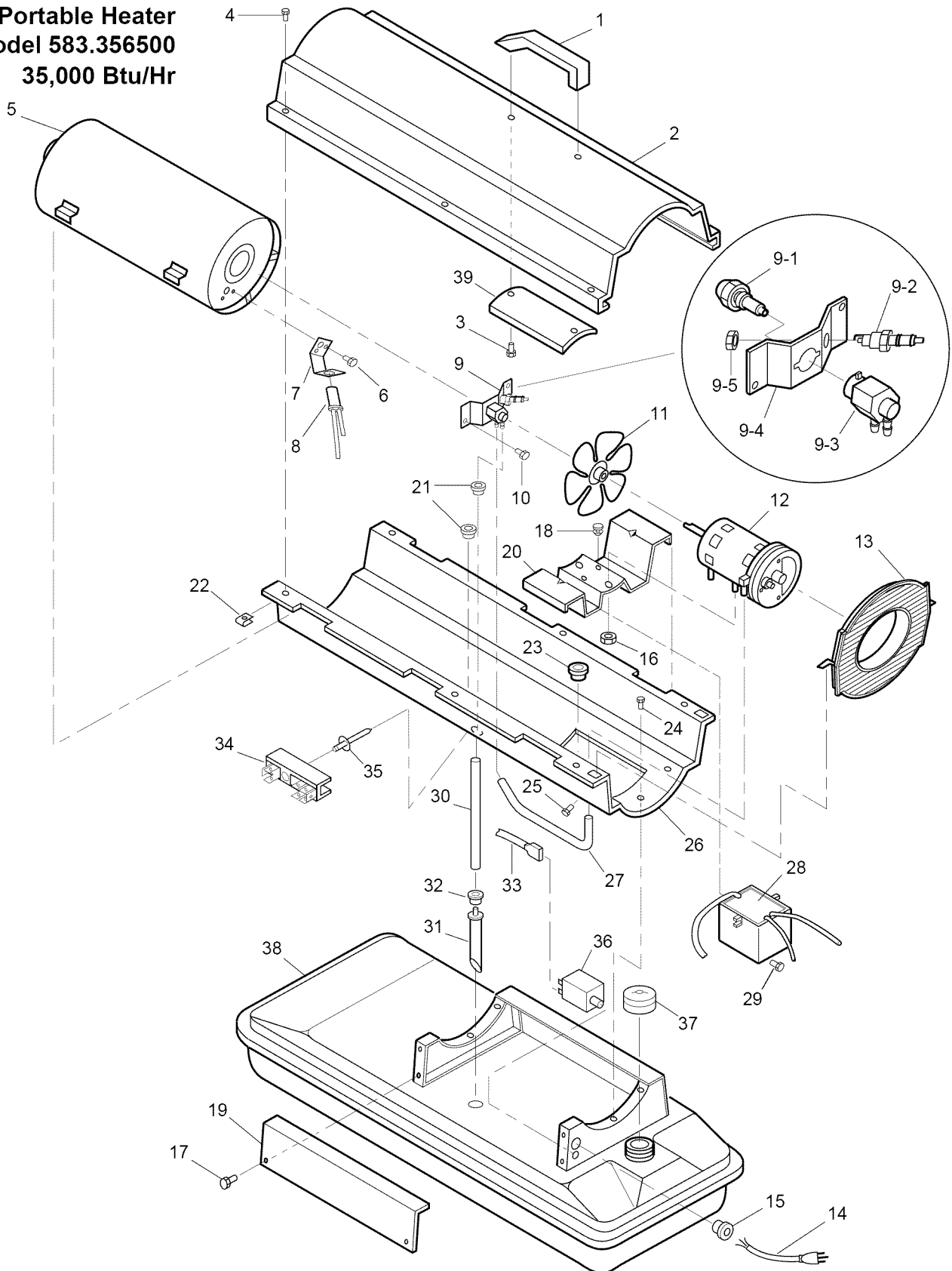



# PARTS LIST

Sears Portable Heater

Model 583.356500

35,000 Btu/Hr

KEY NO.	PART NUMBER	DESCRIPTION	QTY.	KEY NO.	PART NUMBER	DESCRIPTION	QTY.
1	M51104-01	Handle	1	13	M51105-01	Fan Guard	1
2	098511-156	Upper Shell	1	14	098219-18	Power Cord	1
3	M11084-29	Screw, #10-16 x 3/4"	2	15	M11143-1	Strain Relief Bushing	1
4	M15823-27	Screw, #10-16 x 1/2"	6	16	NTC-4C	Hex Lock Nut, 1/4-20	2
5	098512-05	Combustion Chamber	1	17	M11084-26	Screw, #10-16 x 3/8"	2
6	M10908-2	Screw, #6-32 x 3/8"	2	18	M50631	Rubber Bumper	2
7	M16660	Photocell Bracket	1	19	M50899-03AA	Side Cover	1
8	HA3019	Photocell Assembly	1	20	098138-01	Motor Bracket	1
9	**	Burner Head Assembly	1	21	M30865-02	Bushing	2
9-1	HA3006	Nozzle	1	22	M11271-8	Clip Nut	6
9-2	HA3013	Spark Plug	1	23	M50104-02	Bushing	1
9-3	079980-01	Nozzle Adapter	1	24	M11084-26	Screw, #10-16 x 3/8"	6
9-4	097125-01	Bracket	1	25	M15823-37	Screw, #8-18 x 1/4"	1
9-5	M29824	Nut, 14 mm	1	26	098511-155	Lower Shell	1
10	M11084-26	Screw, #10-16 x 3/8"	2	27	M29652-04	Rubber Airline	1
11	M30884	Fan	1	28	098557-06	Ignitor Kit	1
12	**	Motor and Pump Assembly	1	29	M11084-29	Screw, #10-16 x 3/4"	2
12-1	097073-02	Motor	1	30	M29652-05	Fuel Line	1
12-2	079975-01	Pump Body	1	31	M50876-04	Fuel Filter (With Bushing)	1
12-3	M22009	Insert	1	32	M10990-3	Rubber Bushing	1
12-4	M22456-1	Rotor	1	33	M16841-57	Wire Assembly (Red, 6")	1
12-5	M29608	Pump End Cover	1	34	099125-02	Terminal Board	1
12-6	M29632	Lint Filter	1	35	099157-01	Rivet	1
12-7	M29633	Intake Filter	1	36	HA3003	Flame-Out Control	1
12-8	M29609	Filter End Cover	1	37	097702-01	Fuel Cap (Includes Gasket)	1
12-9	M12461-31	Screw, #10-32 x 1"	3	38	098513-23	Fuel Tank	1
12-10	M27694	Adjusting Screw	1	39	M51108-01	Heat-Shell Shield	1
12-11	M10993-1	Pressure Relief Spring	1	<b>PARTS AVAILABLE - NOT SHOWN</b>			
12-12	M22997	Plug	1				
12-13	M8940	Steel Ball, 1/4" Diameter	1		097072-04	General Information Decal	
12-14	M29612-01	Output Filter	1		100506-01	Owner's Manual	
12-15	M12461-31	Screw, #10-32 x 1"	6				
12-16	M50016	Elbow, 90°	1				
12-17	M8643	Blade	4				
12-18	FHPF3-2C	Screw, #10-32 x 1/4"	2				

\*\* Not available as an assembly.

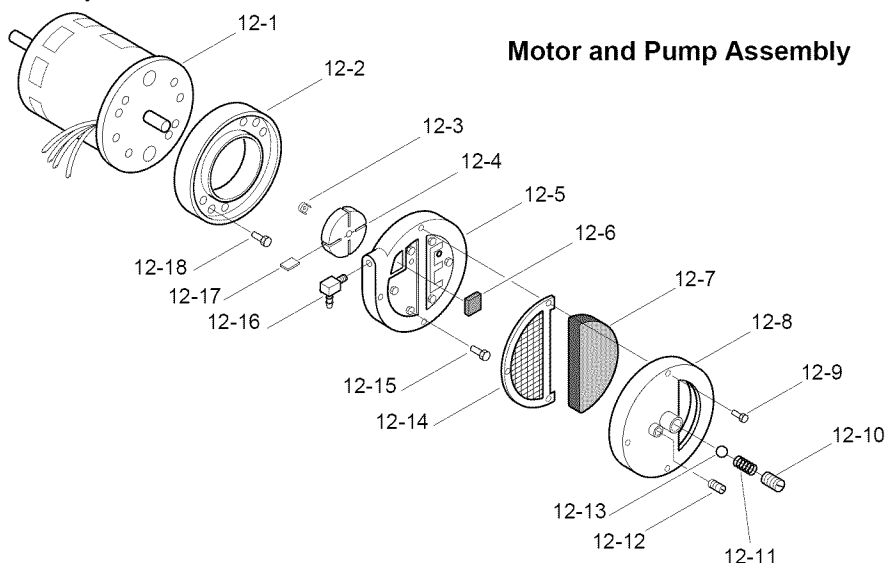

# ILLUSTRATED PARTS BREAKDOWN

Sears Portable Heater  
Model 583.356820  
55,000 Btu/Hr

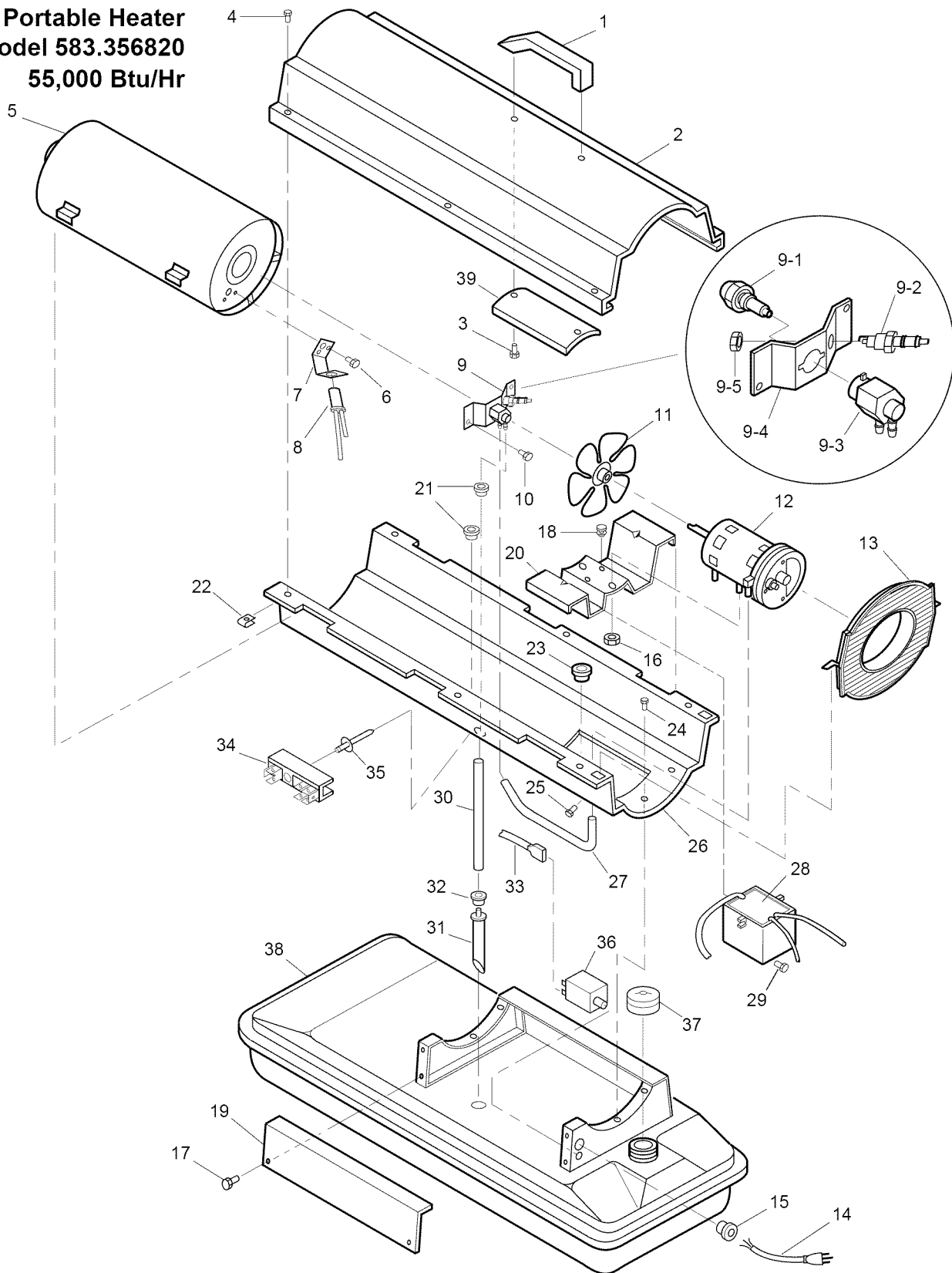

# PARTS LIST

Sears Portable Heater  
 Model 583.356820  
 55,000 Btu/Hr

KEY NO.	PART NUMBER	DESCRIPTION	QTY.	KEY NO.	PART NUMBER	DESCRIPTION	QTY.
1	M51104-01	Handle	1	13	M51105-01	Fan Guard	1
2	098511-156	Upper Shell	1	14	098219-18	Power Cord	1
3	M11084-29	Screw, #10-16 x 3/4"	2	15	M11143-1	Strain Relief Bushing	1
4	M15823-27	Screw, #10-16 x 1/2"	6	16	NTC-4C	Hex Lock Nut, 1/4-20	2
5	098512-32	Combustion Chamber	1	17	M11084-26	Screw, #10-16 x 3/8"	2
6	M10908-2	Screw, #6-32 x 3/8"	2	18	M50631	Rubber Bumper	2
7	M16660	Photocell Bracket	1	19	M50899-03AA	Side Cover	1
8	HA3019	Photocell Assembly	1	20	098138-01	Motor Bracket	1
9	**	Burner Head Assembly	1	21	M30865-02	Bushing	2
9-1	HA3021	Nozzle	1	22	M11271-8	Clip Nut	6
9-2	HA3013	Spark Plug	1	23	M50104-02	Bushing	1
9-3	079980-01	Nozzle Adapter	1	24	M11084-26	Screw, #10-16 x 3/8"	6
9-4	097125-01	Bracket	1	25	M15823-37	Screw, #8-18 x 1/4"	1
9-5	M29824	Nut, 14 mm	1	26	098511-155	Lower Shell	1
10	M11084-26	Screw, #10-16 x 3/8"	2	27	M29652-04	Rubber Airline	1
11	M30884	Fan	1	28	098557-06	Ignitor Kit	1
12	**	Motor and Pump Assembly	1	29	M11084-29	Screw, #10-16 x 3/4"	2
12-1	100088-01	Motor	1	30	079973-01	Fuel Line	1
12-2	M8645-2	Pump Body	1	31	M50876-05	Fuel Filter (With Bushing)	1
12-3	M22009	Insert	1	32	M10990-3	Rubber Bushing	1
12-4	M22456-2	Rotor	1	33	M16841-57	Wire Assembly (Red, 6")	1
12-5	M29608	Pump End Cover	1	34	099125-02	Terminal Board	1
12-6	M29632	Lint Filter	1	35	099157-01	Rivet	1
12-7	M29633	Intake Filter	1	36	HA3003	Flame-Out Control	1
12-8	M29609	Filter End Cover	1	37	097702-01	Fuel Cap (Includes Gasket)	1
12-9	M12461-31	Screw, #10-32 x 1"	3	38	098513-24	Fuel Tank	1
12-10	M27694	Adjusting Screw	1	39	M51108-01	Heat-Shell Shield	1
12-11	M10993-1	Pressure Relief Spring	1	<b>PARTS AVAILABLE - NOT SHOWN</b>			
12-12	M22997	Plug	1				
12-13	M8940	Steel Ball, 1/4" Diameter	1		098221-18	General Information Decal	
12-14	M29612-01	Output Filter	1		100506-01	Owner's Manual	
12-15	M12461-31	Screw, #10-32 x 1"	6				
12-16	M50016	Elbow, 90°	1				
12-17	M8643-2	Blade	4				
12-18	FHPF3-5C	Screw, #10-32 x 1/4"	2				

\*\* Not available as an assembly.

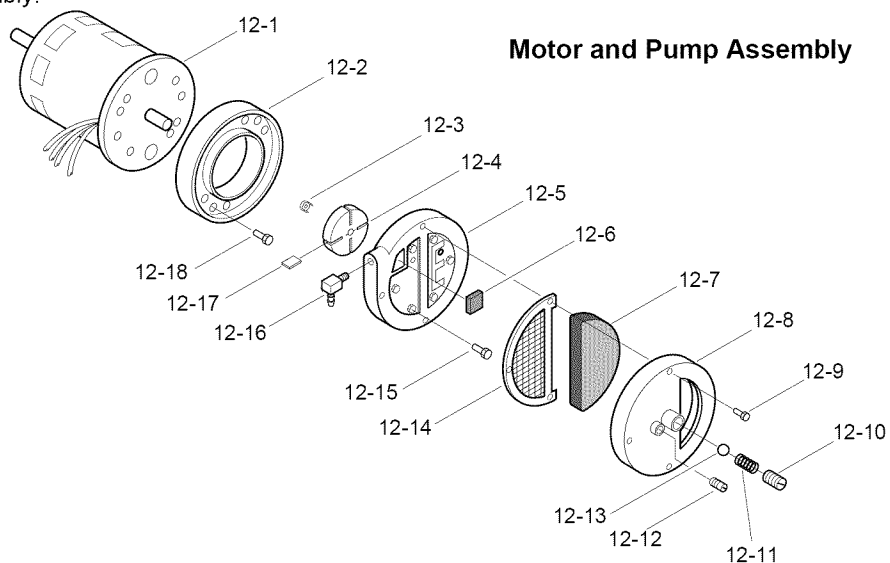

# ILLUSTRATED PARTS BREAKDOWN

Sears Portable Heater  
Model 583.356830  
110,000 Btu/Hr

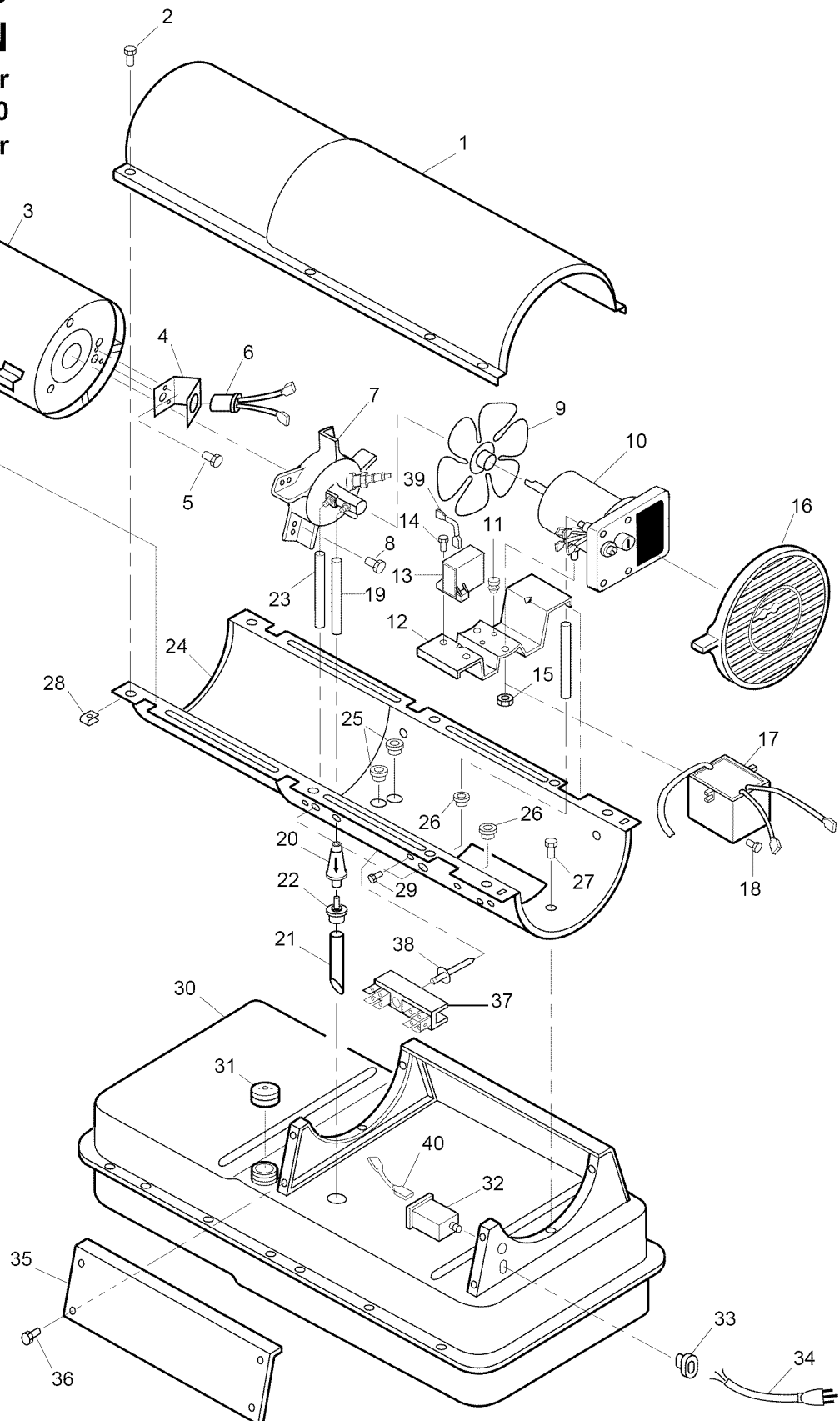

# PARTS LIST

Sears Portable Heater  
 Model 583.356830  
 110,000 Btu/Hr

KEY NO.	PART NUMBER	DESCRIPTION	QTY.	KEY NO.	PART NUMBER	DESCRIPTION	QTY.
1	098511-158	Upper Shell	1	11	M50631	Rubber Bumper	2
2	M15823-27	Screw, #10-16 x 1/2"	8	12	098138-02	Motor Mounting Bracket	1
3	098512-31	Combustion Chamber	1	13	097061-01	Solid State Relay	1
4	M16660	Photocell Bracket	1	14	M15823-39	Screw, #8-18 x 1/2"	2
5	M10908-2	Screw, #6-32 x 3/8"	2	15	NTC-4C	Hex Lock Nut, 1/4-20	2
6	HA3019	Photocell Assembly	1	16	M51114-01	Fan Guard	1
7	**	Burner Head Assembly	1	17	098557-06	Ignitor Kit	1
7-1	HA3022	Nozzle with Sleeve	1	18	M11084-29	Screw, #10-16 x 3/4"	2
7-2	M10659-1	Nozzle Washer	2	19	M51345-01	Fuel Line	1
7-3	M10809-1	Nozzle Spring	1	20	M51150-01	Fuel Filter	1
7-4	M8882	Nozzle Sleeve	1	21	M51151-01	Fuel Line Tube	1
7-5	M50924-03	Burner Head Body	1	22	M10990-3	Rubber Bushing	1
7-6	M50820-02	Barb Fitting	2	23	M50814-03	Airline	1
7-7	HA3012	Spark Plug	1	24	098511-157	Lower Shell	1
8	M11084-27	Screw, #10-16 x 1/2"	3	25	M50104-03	Bushing	2
9	097293-01	Fan	1	26	M50104-01	Bushing	2
10	**	Motor and Pump Assembly	1	27	M11084-27	Screw, #10-16 x 1/2"	6
10-1	097300-02	Motor (Split Phase)	1	28	M11271-8	Clip Nut	8
10-2	079975-01	Pump Body	1	29	M15823-37	Screw, #8-18 x 1/4"	1
10-3	FHPF3-2C	Screw, #10-32 x 1/2"	2	30	098513-21	Fuel Tank	1
10-4	M22009	Rotor Insert	1	31	097702-01	Fuel Cap (Includes Gasket)	1
10-5	M22456-1	Pump Rotor	1	32	HA3003	Flame-Out Control	1
10-6	M50545	Pump End Cover	1	33	M11143-1	Strain Relief Bushing	1
10-7	M12179	Intake Filter	1	34	098219-19	Power Cord	1
10-8	M16545	Filter End Cover	1	35	M51077-01AA	Side Cover	1
10-9	M8940	Steel Ball, 1/4" Diameter	1	36	M11084-27	Screw, #10-16 x 1/2"	4
10-10	M10993-1	Relief Spring	1	37	099125-03	Terminal Board	1
10-11	M27694	Adjusting Screw	1	38	099157-01	Rivet	1
10-12	M22997	Plug	1	39	079010-20	Wire Assembly (Red, 14 1/2")	1
10-13	M12461-31	Screw, #10-32 x 1"	10	40	M16841-57	Wire Assembly (Red, 6")	1
10-14	M12244-1	Output Filter	1	<b>PARTS AVAILABLE - NOT SHOWN</b>			
10-15	M11637	Lint Filter	1		097083-03	General Information Decal	
10-16	M50820-02	Barb Fitting	1		100506-01	Owner's Manual	
10-17	M8643	Blade	4				

\*\* Not available as an assembly.

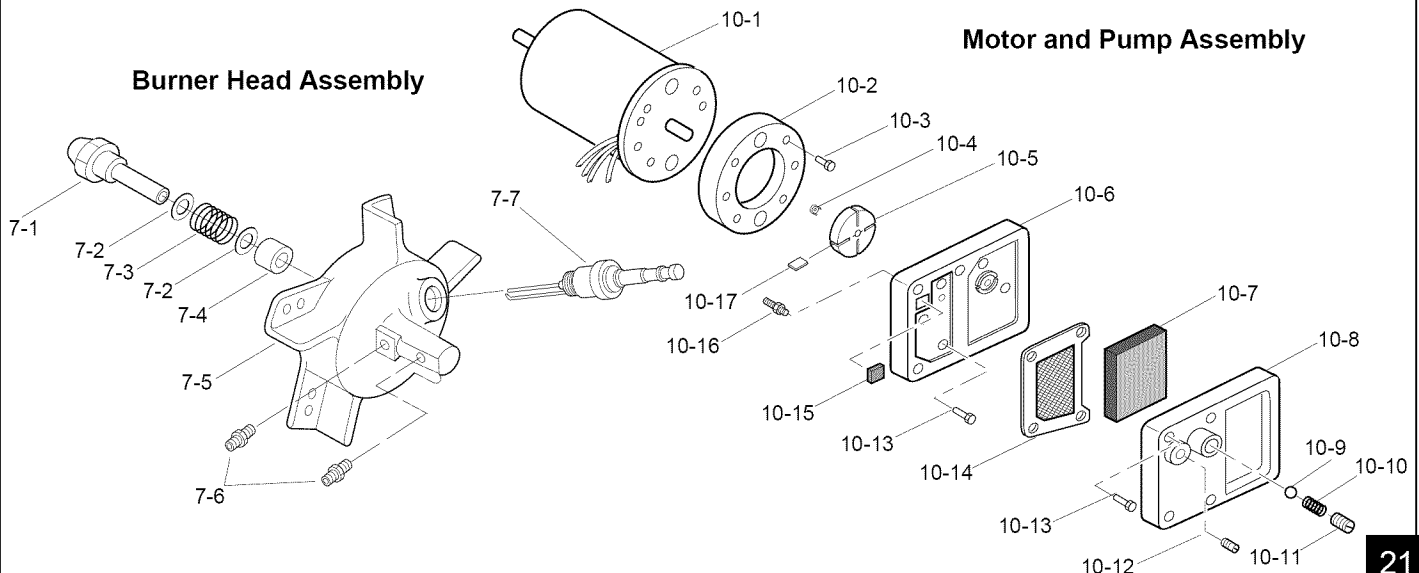

# WHEELS AND HANDLE PARTS LIST

For 110,000  
Btu/Hr Model

KEY NO.	PART NUMBER	PART DESCRIPTION	110,000 QTY.
1	HA2203	Handle	1
2	M12345-33	Screw, #10-24 x 1 3/4"	8
3	M12342-3	Wheel Support Frame	1
4	NTC-3C	Lock Nut, #10-24	8
5	097896-01	Wheel	2
6	M28526	Cap Nut	2
7	M51015-01	Axle	1
8	M51123-01	Tube Cap	2

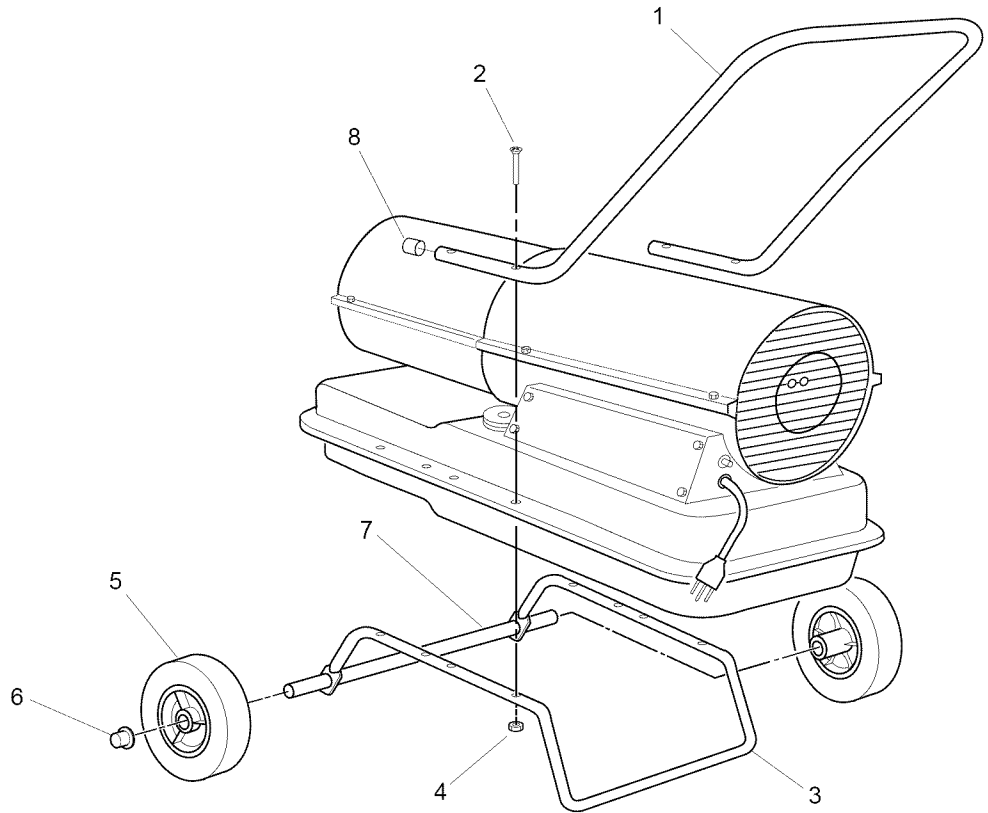





**OWNER'S  
MANUAL**

**HOW TO ORDER  
REPAIR PARTS**

**MODEL  
NUMBERS:  
583.356500  
583.356820  
583.356830**

**SEARS  
PORTABLE HEATERS**

Now that you have purchased your portable heater, should a need ever exist for repair parts or service, simply contact any Sears service center. Be sure to provide all pertinent facts when you call or visit. The model and serial number of your portable heater will be found on a decal located on side of the Heater.

**WHEN ORDERING REPAIR PARTS,  
ALWAYS GIVE THE FOLLOWING INFORMATION:**

1. Part Number
2. Model Number
3. Part Description
4. Name or Merchandise

If the parts you need are not stocked locally, your order will be electronically transmitted to a Sears Repair Parts Distribution Center for "expedited handling."

---

**Sold by Sears, Roebuck and Co., 3333 Beverly Road, Hoffman Estates, IL 60179**