

# SEARS

OWNERS  
MANUAL

HOME  
CLEANING  
SYSTEM

MODEL NO.  
175.8579280

**CAUTION:**  
Read Instructions  
and Rules for  
Safe Operation  
Carefully

For household  
use only.

Save this  
Manual for  
Future Reference

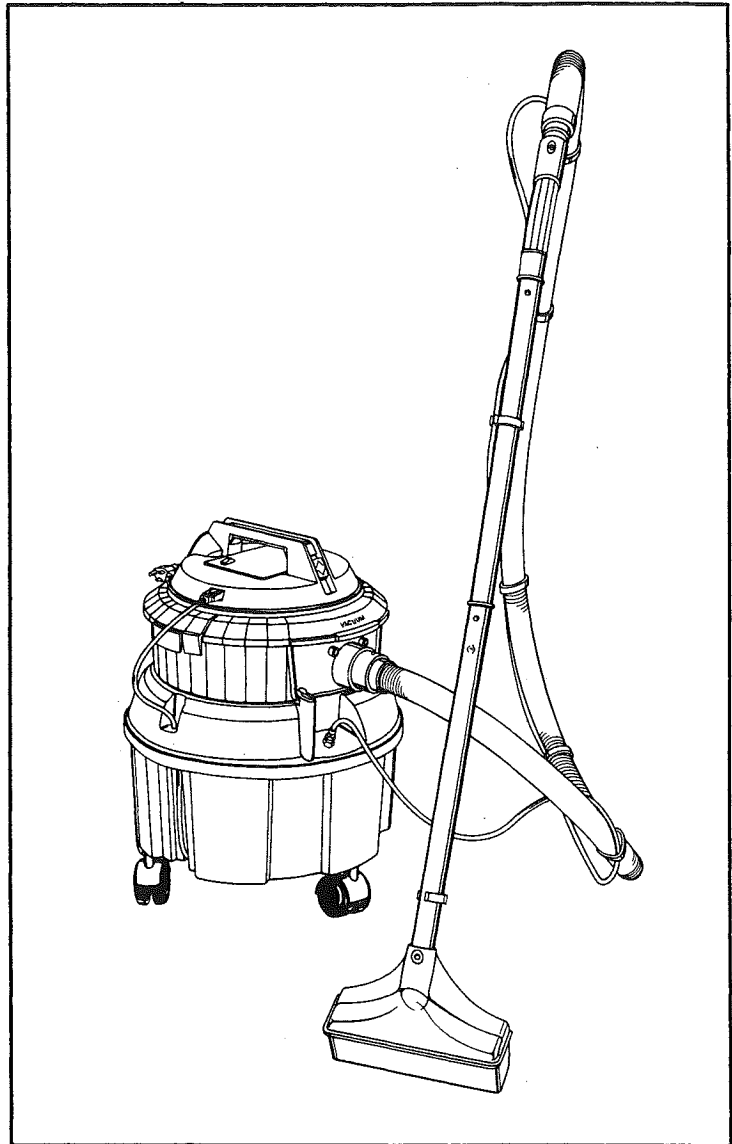

## **Kenmore** HOME CLEANING SYSTEM

- INTRODUCTION
- ASSEMBLY
- OPERATION
- MAINTENANCE
- REPAIR PARTS



SEARS, ROEBUCK AND CO., Dept. 698/731A, Sears Tower, Chicago, IL 60684

5553282  
(1289)

PRINTED IN U.S.A.

# IMPORTANT SAFETY INSTRUCTIONS — Read all instructions before using this cleaner.

When using any electrical appliance, basic precautions should always be followed, including the following:

## WARNING — To reduce the risk of fire, electric shock, or injury:

1. Do not leave cleaner when plugged into electrical outlet. Unplug from outlet when not in use and before servicing.
2. **WARNING: TO AVOID ELECTRIC SHOCK, DO NOT EXPOSE TO RAIN — STORE INDOORS.**
3. **WARNING: DO NOT REMOVE GROUNDING PRONG FROM POWER CORD PLUG.** Connect to a properly grounded outlet ONLY. See Grounding Instructions.

### GROUNDING INSTRUCTIONS:

This vacuum cleaner must be grounded. If it should malfunction or break down, grounding provides a path of least resistance for electrical current to reduce the risk of electric shock. This vacuum cleaner is equipped with a cord having an equipment-grounding conductor and grounding plug. The plug must be plugged into an appropriate outlet that is properly installed and grounded in accordance with all local codes and ordinances.

**WARNING:** Improper connection of the equipment-grounding conductor can result in a risk of electric shock. Check with a qualified electrician or service person if you are in doubt as to whether the outlet is properly grounded. **DO NOT** modify the plug provided with the vacuum cleaner — if it will not fit the outlet, have a proper outlet installed by a qualified electrician.

This vacuum cleaner is for use on a nominal 120 -volt circuit, and has a grounded plug (see figure A). A temporary adapter (see figure B) may be used to connect this plug to a 2-pole receptacle (see figure B) if a properly grounded outlet is not available. The tempo-

rary adapter should be used only until a properly grounded outlet (see figure A) can be installed by a qualified electrician. The tab for grounding screw (see figure B) extending from the adapter must be connected to a permanent ground such as a properly grounded outlet box cover. Whenever the adapter is in use, it must be held in place by a metal screw (see Figure B).

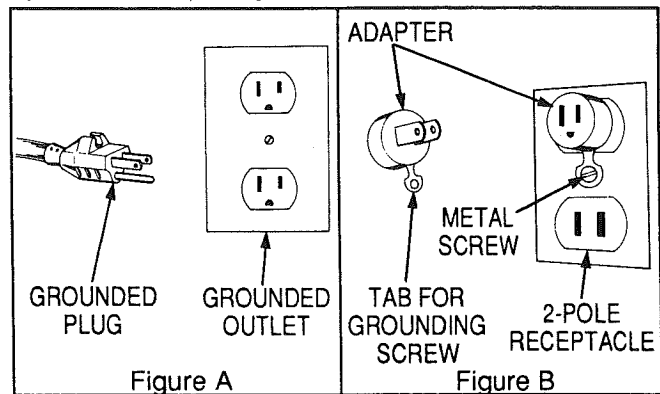

4. **DISCONNECT POWER CORD FROM ELECTRICAL OUTLET** before the recovery tank is emptied, the solution tank is refilled, or the cleaner is serviced in any way.
5. **DO NOT** store this cleaner in an area which may reach freezing temperatures. Should this occur, **DO NOT** operate this cleaner until it has been at room temperature for at least two (2) hours.
6. **DO NOT** use any cleaning solution or chemicals other than those discussed in this manual.
7. For maximum efficiency, empty container frequently and keep inside of hose, wands, nozzle and container clean.
8. **DO NOT** overwet carpet or upholstery. If three or more cleaning strokes are required, let the carpet or upholstery material dry and then repeat cleaning process.
9. Do not allow children to operate cleaner, nor should they play with cleaner as a toy. Close attention is necessary when used around or near children.
10. Use this cleaner **ONLY** for its intended use as described in this manual. Use only the attachments recommended in this manual.
11. Always turn cleaner **OFF** when connecting or disconnecting the Spraymate motorized nozzle.
12. Do not use with damaged cord or plug. If cleaner is not working properly, has been dropped, damaged, left outdoors, or dropped into water, return it to a Sears Service Center.
13. Do not pull or carry by cord, nor use cord as a handle, nor close a door on cord, nor pull cord around sharp edges or corners. Do not run cleaner over cord. Keep away from heated surfaces.
14. Do not unplug from electrical outlet by pulling on the cord. To unplug, grasp the plug, not the cord, and pull.
15. Do not handle plug or cleaner with wet hands.
16. Do not put any objects in ventilation openings. Do not use with any opening blocked; keep openings free of dust, lint, hair, and anything that may reduce air flow.
17. Keep hair, loose clothing, fingers, and all parts of the body away from openings and moving parts.
18. **NEVER** vacuum materials such as hot coals, cigarette butts, matches, etc.
19. When "dry" vacuuming do not use without filter in place.
20. Turn off all controls before unplugging.
21. Use extra care when using on stairs.
22. Do not use to pick up flammable or combustible liquids such as gasoline or use in areas where such liquids may be present.

— SAVE THESE INSTRUCTIONS —

## TABLE OF CONTENTS

Warranty .....	page 3
Safety Instructions .....	page 2
Introduction .....	page 3
Assembly .....	page 4
Operation .....	page 5-8
Additional Uses / Optional Accessories .....	page 8-9
Trouble Shooting Chart .....	page 10
Exploded Views and Parts Lists .....	page 11-15
Ordering Parts .....	page 16

## FULL ONE YEAR WARRANTY

When used for private household purposes, if within one year from the date of purchase, this vacuum cleaner fails due to a defect in material or workmanship, RETURN IT TO THE NEAREST SEARS SERVICE CENTER/DEPARTMENT IN THE UNITED STATES, and Sears will repair it, free of charge.

If this vacuum cleaner is used for commercial or rental purposes, the above warranty coverage applies for only 90 days from the date of purchase.

This warranty gives you specific legal rights, and you may also have other rights, which vary from state to state .  
SEARS, ROEBUCK AND CO., D/731CR-W, SEARS TOWER, CHICAGO, IL 60684

## INTRODUCTION

Your new Kenmore Home Cleaning System is a deluxe high performance cleaner, designed for today's cleaning requirements.

With proper care and maintenance, it should provide you with years of service. It is important that you read this manual to fully understand the cleaner's capabilities as well as providing you with the essentials regarding maintenance and safety. A complete list of operating parts and features is shown in figure 1 below.

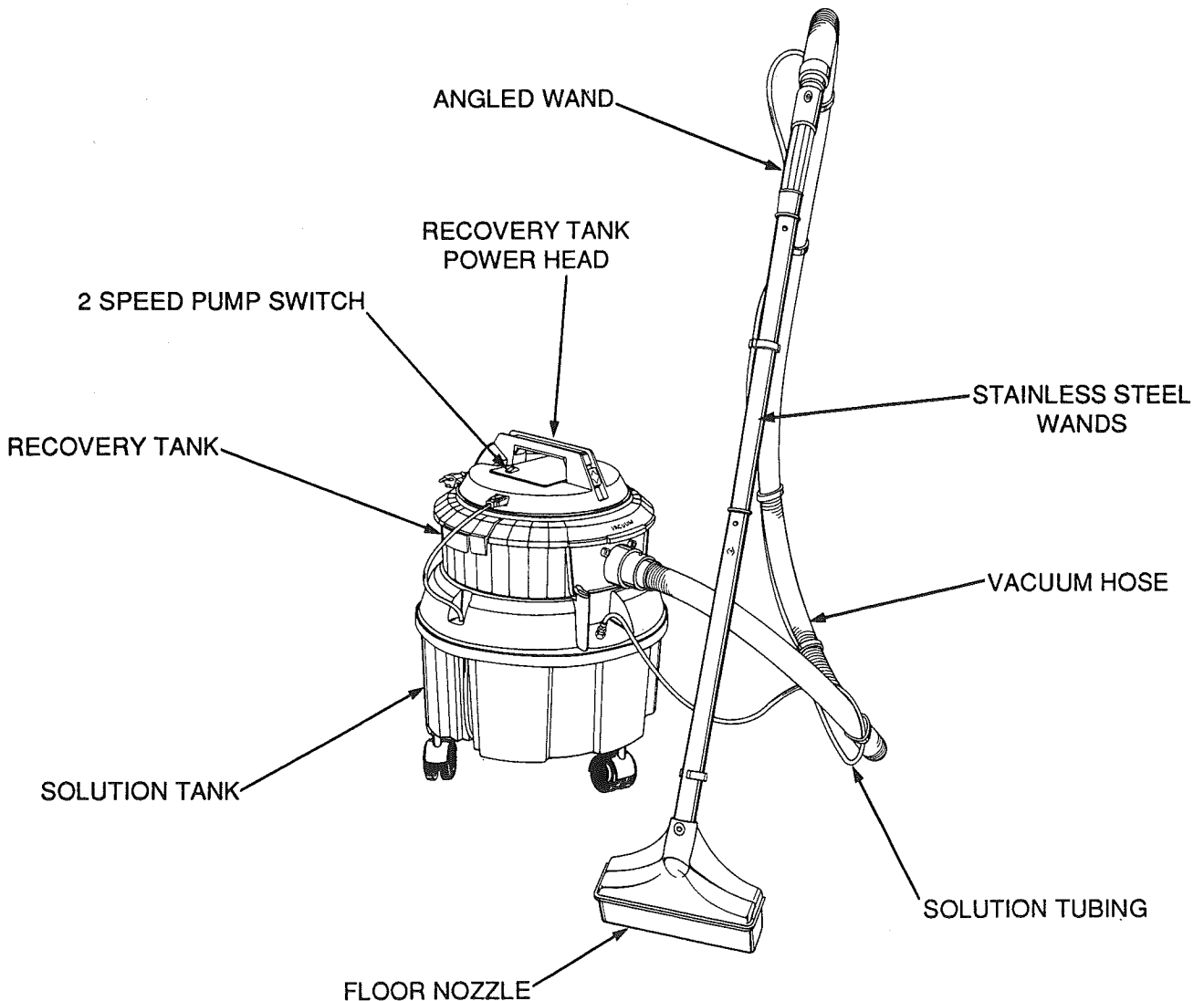

Fig. 1

# ASSEMBLY

## ASSEMBLY OF RECOVERY TANK AND SOLUTION TANK

See Figure 2

1. Place Recovery Tank into Solution Tank (align the word "VACUUM" on Recovery Tank with "VACUUM" on Solution Tank) and secure with Metal Latch.
2. Unwind Power Cord from the Power Head.
3. Insert the plug on the Short Cord from the Solution Tank into the Recovery Tank Power Head.

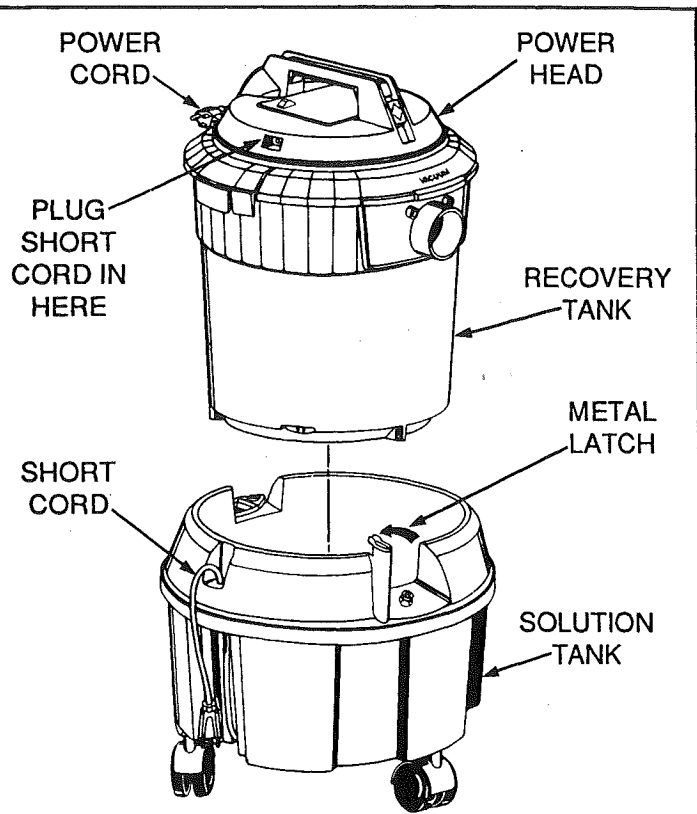

Fig. 2

## ASSEMBLY OF HOSE, WANDS, NOZZLE AND SOLUTION TUBING

See Figure 3

1. Assemble the two Straight Wands.
2. Assemble the upper Straight Wand to the Angled Wand of the Hose.
3. Assemble the Floor Nozzle to the lower Straight Wand.

NOTE: Be sure locking button engages properly when assembling straight wands, angled wand, and floor nozzle.

See DETAIL "A" - Figure 3.

4. Thread Solution Tube Nut onto threads of the Trigger Valve.
5. Snap Solution Tubing onto Retaining Clips on the Wands.

See DETAIL "B" - Figure 3.

6. Attach the Vacuum Hose to Recovery Tank inlet (Vacuum Inlet).
7. Insert the Plastic Insert of the Solution Tubing into the Coupling of the Solution Tank.

NOTE: To remove the Plastic Insert depress the Tab and gently pull on the Plastic Insert. Be careful to pull on the Plastic Insert and not the Tubing as damage may occur.

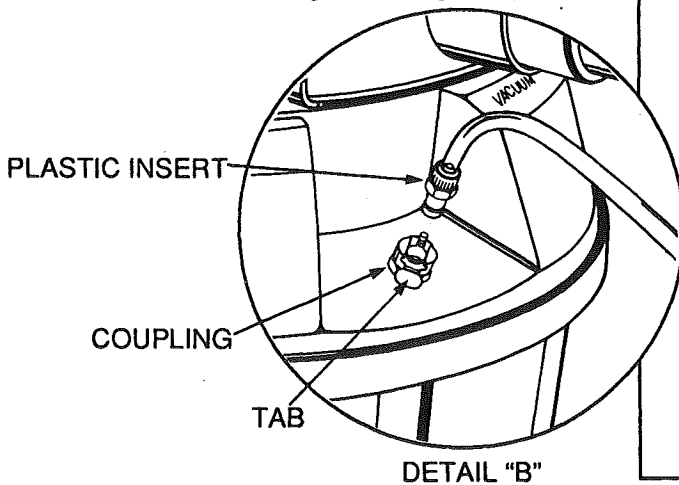

DETAIL "B"

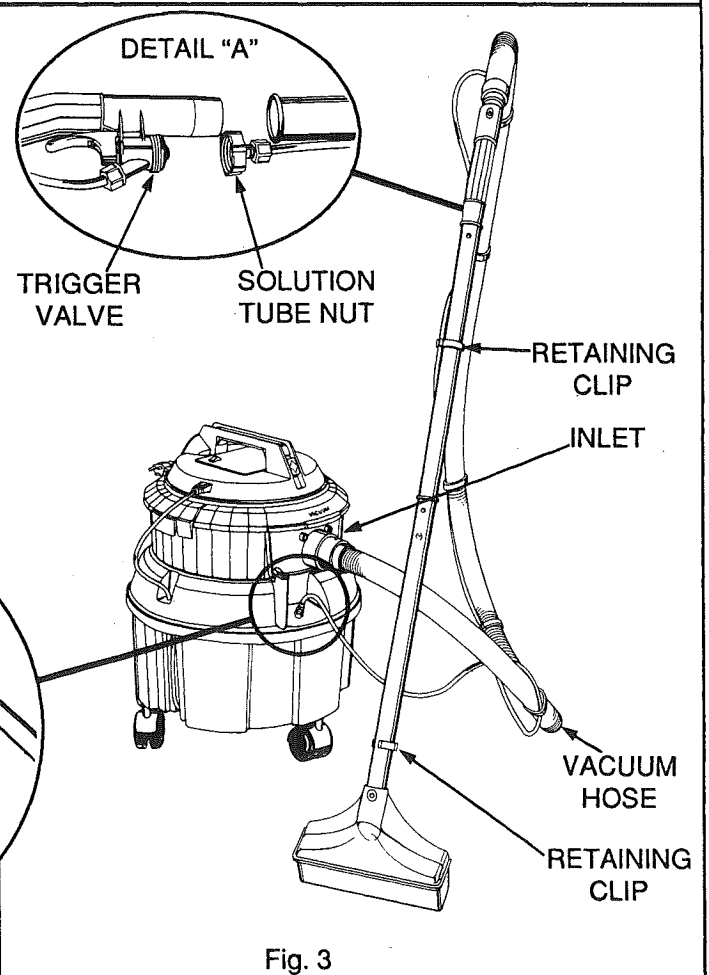

Fig. 3

# OPERATION

## CARPET PREPARATION

For best results prepare carpet for cleaning as follows:

1. Vacuum carpet to remove loose dirt before using Cleaner.
2. To remove stains and ground in dirt present in heavy traffic areas of the carpet, spray or rub Sears Heavy Traffic Pre-Treatment (82833) into carpet before using Cleaner. Follow directions on the bottle.

## FILLING CLEANER WITH WATER AND CLEANING SOLUTION

See Figure 4

1. Open lid of the Filler Opening.
2. Add Sears All In One Carpet Cleaner (82813) solution or Sears Upholstery Cleaner (82843) solution to Solution Tank (depending on type of cleaning to be performed). Follow directions on label of bottle.
3. Pour clean, hot water (from tap) into Filler Opening in the Solution Tank — use two (2) gallons of water.
4. Close Filler Opening.

NOTE: This unit may become damaged if boiling water is used.

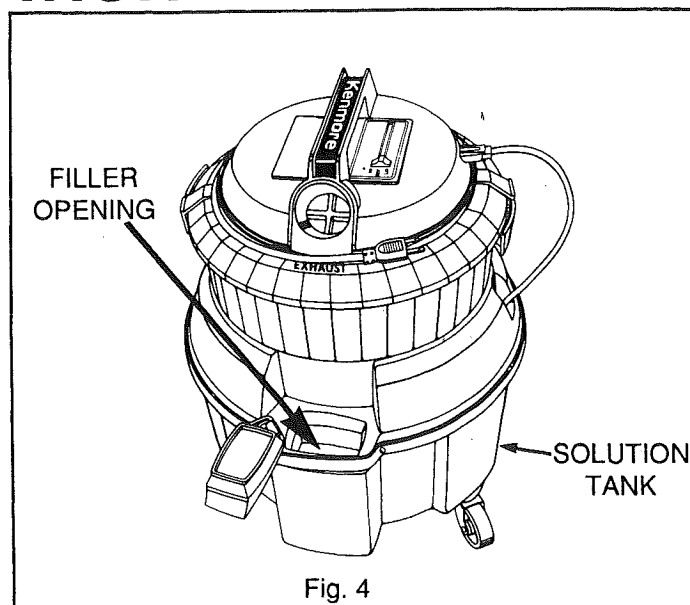

## POWER CORD AND SWITCH

See Figure 5

1. Unwrap Power Cord from around Power Head and plug into electrical outlet.
2. Turn Power Switch to "ON" position.

## PUMP SWITCH

See Figure 5

1. Place Pump Switch from "OFF" position to either "HI" or "LO" position.

NOTE: "HI" pump speed is used for normal cleaning. "LO" pump speed is used for delicate upholstery or light cleaning.

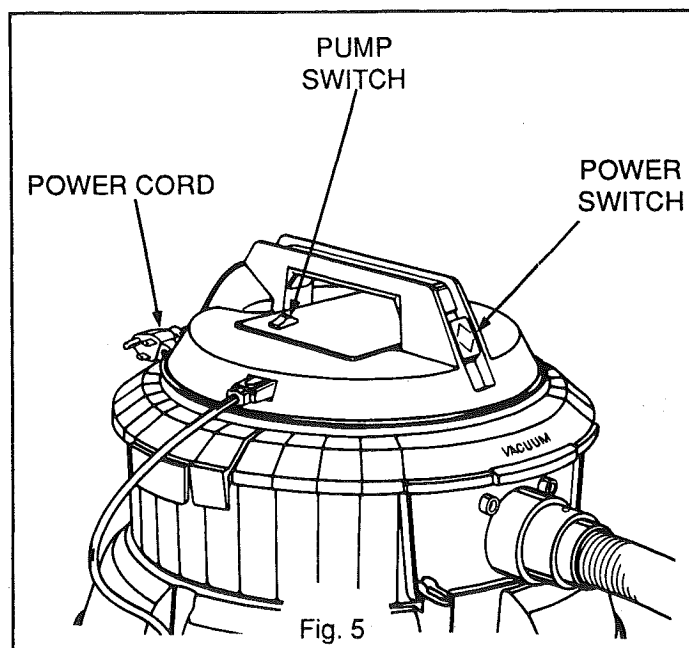

— Continued —

# OPERATION

## TEST FOR SOLUTION SPRAY

See Figure 6

1. Hold Floor Nozzle above floor level.
2. Pull Solution Release Trigger on Angled Wand.
3. Observe Floor Nozzle to make sure cleaning solution is being sprayed evenly from two points. (see *DETAIL "A"*)

NOTE: If solution is not being sprayed from both points, refer to Trouble Shooting Chart.

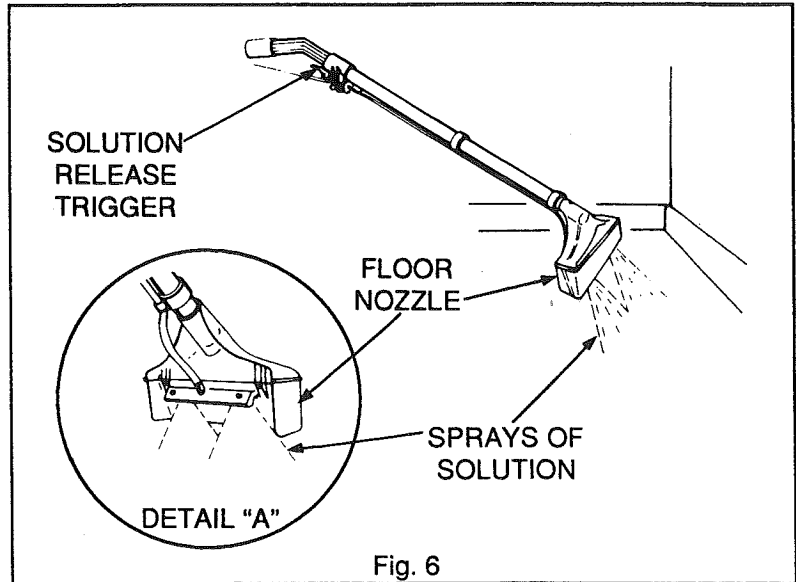

## CLEANING THE CARPET

See Figures 7 & 8

### Solution Dispensing Stroke:

1. Start at a corner (recommended).
2. Place Floor Nozzle so Suction Inlets are flush with carpet.
3. While exerting light pressure down on Floor Nozzle, depress Solution Release trigger and slowly pull Floor Nozzle towards you.

NOTE: Do not overwet. If three or more cleaning strokes are required, let dry and then repeat cleaning process.

### Solution Recovery Stroke:

1. Release Solution Release Trigger.
2. Lift Floor Nozzle off carpet.
3. Return Floor Nozzle to point where you dispensed cleaning solution and pull across carpet, recovering dirty solution.

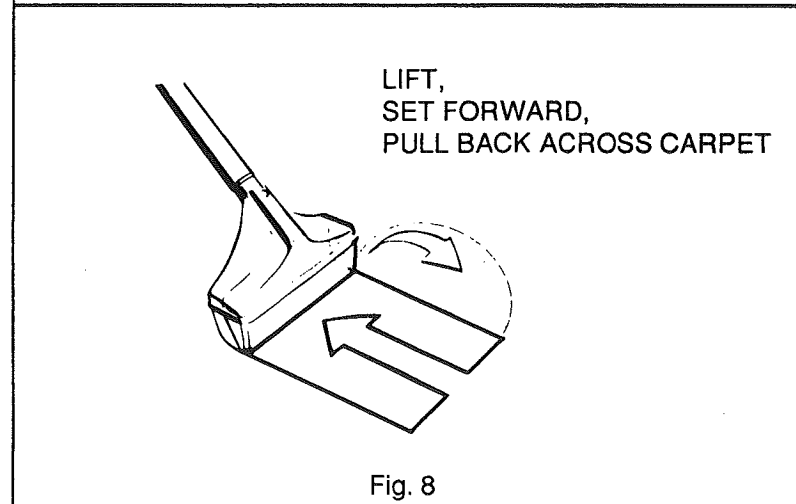
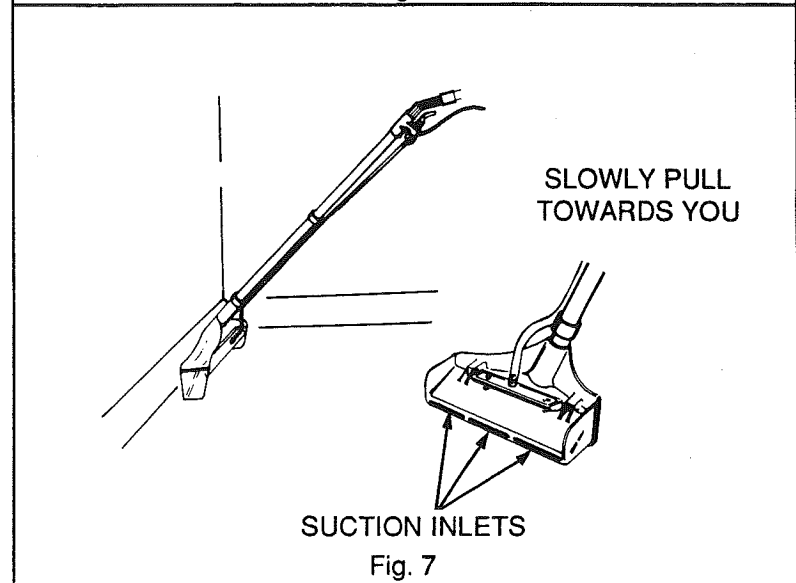

# OPERATION

## WHEN TO EMPTY RECOVERY TANK

See Figure 9

During normal operation, your cleaner may stop recovering solution from your carpet. When this occurs there are three check points to alert you:

1. An increase in motor noise.
2. No solution visibly being recovered by the floor nozzle.
3. No air coming from the exhaust port of your cleaner.

When this occurs:

1. The Recovery Tank is full and the Float Valve in the Recovery Tank has been activated. The Recovery Tank should be emptied.
- or —
2. The Recovery Tank has foam in the Tank and the Float Valve has been activated.

NOTE: If cleaner is accidentally turned over while in operation, the float may activate and shut off the suction. If this occurs, set the cleaner upright. Turn Power Switch "OFF" and let motor come to a complete stop. Then turn switch back on and continue cleaning.

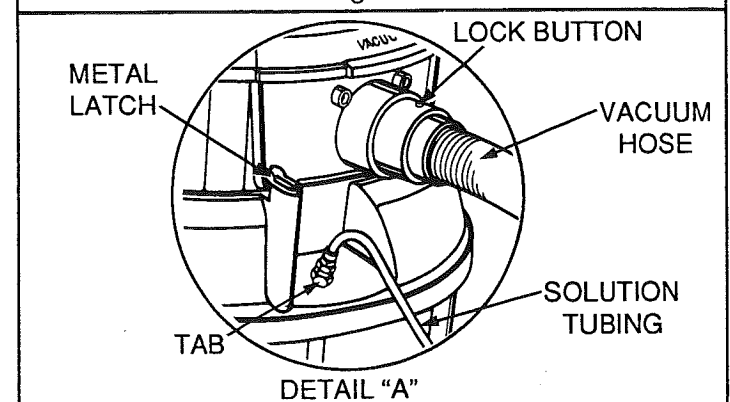
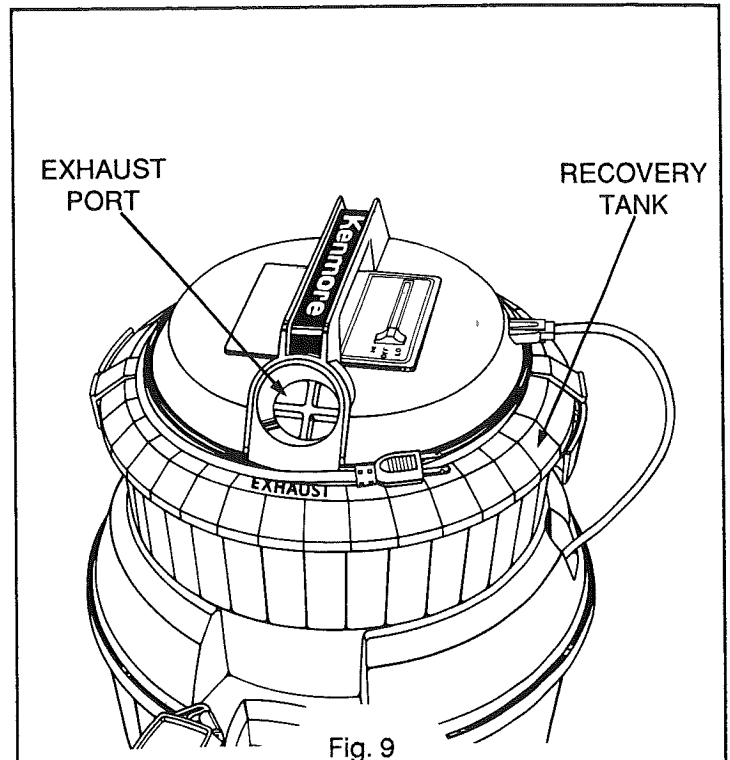

## TO EMPTY RECOVERY TANK

See Figure 10

1. Turn Power Switch "OFF" and Disconnect Power Cord from Electrical Outlet.
2. Disconnect Short Cord located between Solution Tank and Recovery Tank.
3. Disconnect Vacuum Hose by depressing the Lock Button and remove.
4. Push Tab inward on Plastic Coupling and remove Plastic Insert and Tubing. (See DETAIL "A")
5. Lift Latches on Power Head.
6. Lift power Head, by Handle, and remove from Recovery Tank.
7. Rotate Metal Latch on the Solution Tank and lift Recovery Tank from the Solution Tank.
8. Empty Recovery Tank.
9. Reassemble cleaner and resume cleaning.

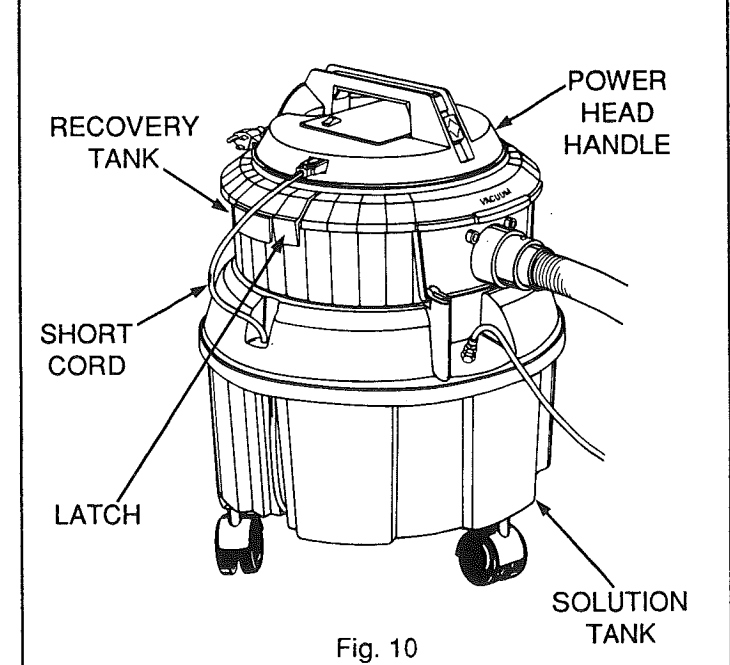

# OPERATION

## TO EMPTY THE SOLUTION TANK

See Figure 11

When cleaning is completed, both the Recovery Tank and the Solution Tank should be emptied prior to storage. Empty the Recovery Tank as described earlier. There are three methods of emptying the Solution Tank.

### Method 1:

1. Disconnect Pump Cord from Recovery Tank.
2. Remove Recovery Tank from Solution Tank and pour solution out of the Filler Opening.

### Method 2:

1. Place Floor Nozzle in bath tub or container.
2. Depress Solution Release Trigger and spray until empty.

### Method 3:

1. Remove Floor Nozzle and insert Wand into Solution Tank through the Filler Opening.
2. Vacuum solution out.
3. All solution is now in Recovery Tank. Empty Recovery Tank as described earlier.

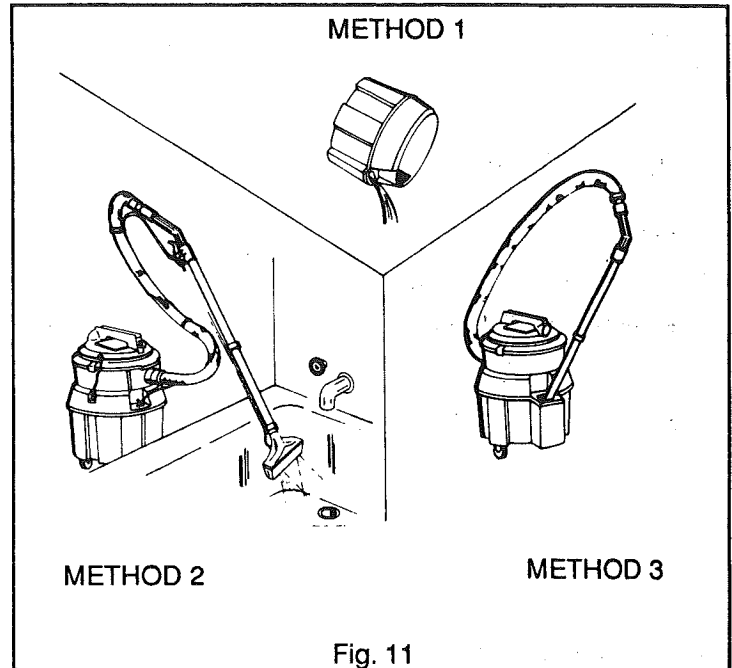

## ADDITIONAL USES

### “DRY” VACUUMING

See Figure 12

KEY	PART NO.	DESCRIPTION
1	643076-008	Floor/Rug Nozzle
2	642458-004	10" Squeegee
3	660408-001	Cloth Filter Assembly

Included with your cleaner are accessories to convert your cleaner to perform dry vacuum cleaning.

1. Insert the Cloth Filter into the Recovery Tank.
2. Use the Floor/Rug Nozzle or the Squeegee Nozzle as desired.

NOTE: You MUST use the Cloth Filter when “dry” cleaning.

NOTE: Squeegee Nozzle is also useful in “pick up” operation of “wet” cleaning.

### USE AS A BLOWER

See Figure 13

1. Insert Hose into the Exhaust Port of the Power Head.
2. Turn Power Switch “ON” and direct hose to area to be blown.

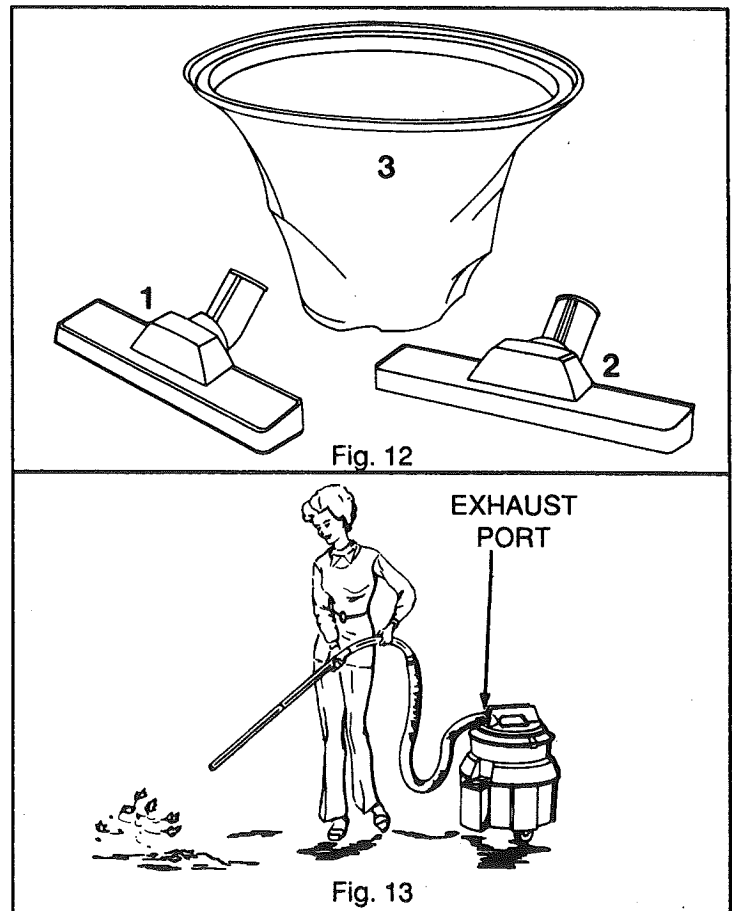



# OPTIONAL CLEANING ACCESSORIES

Optional cleaning accessories may be purchased or ordered through your nearest Sears store. A complete set of instructions comes with each attachment set.

## UPHOLSTERY NOZZLE

Model No. 2081452

See Figure 14

The Kenmore Upholstery Nozzle is an optional attachment for furniture upholstery cleaning. The upholstery nozzle may also be used to clean auto upholstery or carpeting. In addition, the nozzle may also be used to clean carpeted stairs and other areas difficult to clean with the normal floor nozzle.

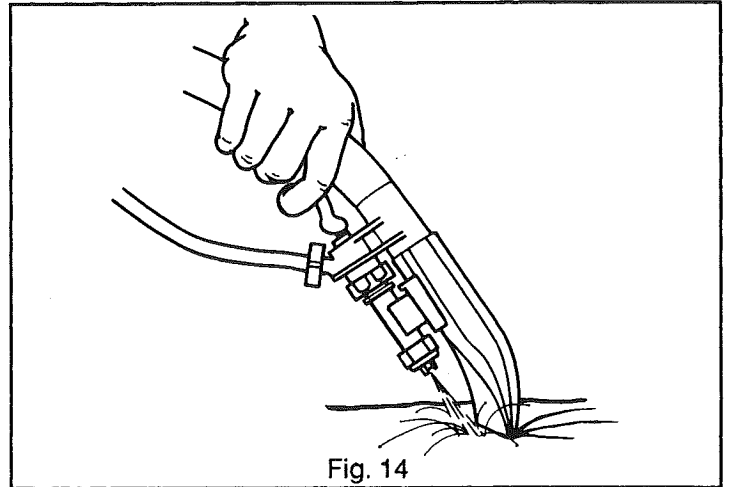

Fig. 14

## KENMORE SPRAYMATE POWER NOZZLE

Model No. 2081252

See Figure 15

The Kenmore Spraymate is an optional attachment for carpet cleaning. The Spraymate has a motorized beater brush which is especially good to scrub difficult to clean areas of heavy traffic.

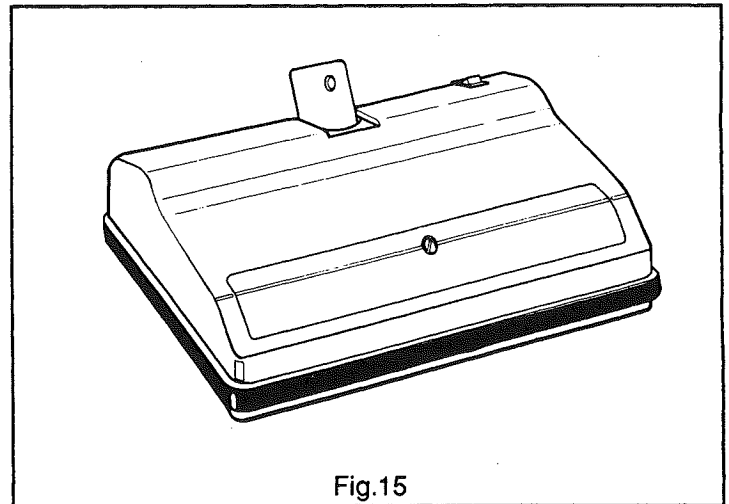

Fig.15

# TROUBLE SHOOTING CHART

PROBLEM	POSSIBLE SOLUTIONS*
1. Neither vacuum motor nor pump motor runs.	<ol style="list-style-type: none"> <li>1. Be sure power switch is in "ON" position.</li> <li>2. Be sure power cord is plugged in securely.</li> <li>3. Check wall electrical outlet (by plugging in a known working electrical appliance).</li> </ol>
2. Vacuum motor runs, but there is no spray at the nozzle.	<ol style="list-style-type: none"> <li>1. Be sure Electrical Cord from Power Head to Solution Tank is securely plugged into receptacle on the Power Head.</li> <li>2. Check that Solution Tank is full.</li> <li>3. Be sure Pump Switch is in the "HI" or "LO" position.</li> <li>4. Nozzle Ports may be clogged. See illustration below to unclog.</li> </ol>
3. Spray from the floor nozzle comes out of one side of the nozzle only.	<ol style="list-style-type: none"> <li>1. Unclog the Nozzle Port. See illustration below.</li> </ol>
4. Motor runs but cleaner does not pick up solution from carpet (no exhaust from top of cleaner).	<ol style="list-style-type: none"> <li>1. Recovery Tank is full of dirty water and must be emptied.</li> <li>2. Check for clogged hose or nozzle. Clogs could result from picking up material such as carpet strings, shoe laces, etc.</li> </ol>
5. Spray connections leak.	<ol style="list-style-type: none"> <li>1. Disassemble nut at leaking connection. Be sure washer is properly seated. Reassemble and tighten securely.</li> </ol>

\* If the "Possible Solutions" to "Problems" listed in the chart do not correct the problem, take your cleaner to a Sears Service Center for professional service. **Repairs not listed in this chart require professional and specific knowledge of this model cleaner and could result in safety hazards and personal injury if not made by a qualified Sears Service Technician.**

## TO UNCLOG NOZZLE PORT

See Figure 16.

1. Remove Access Screws
2. Clean out ports (2) with a small pin.
3. Reassemble.

NOTE: Do not let pin point touch any part of the spray pad surface or spray pad will not spray solution properly.

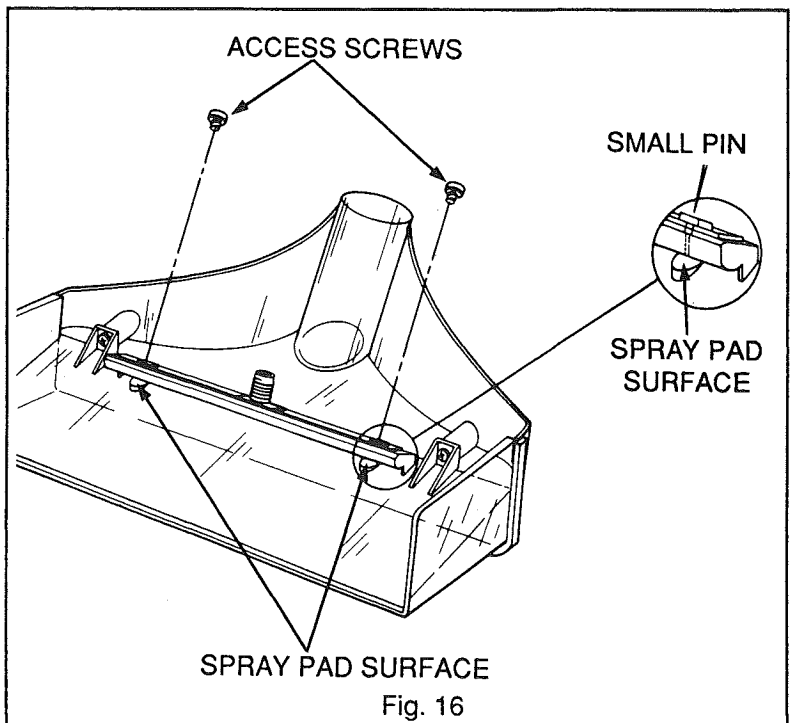

SEARS HOME CLEANING SYSTEM — MODEL 175.8579280

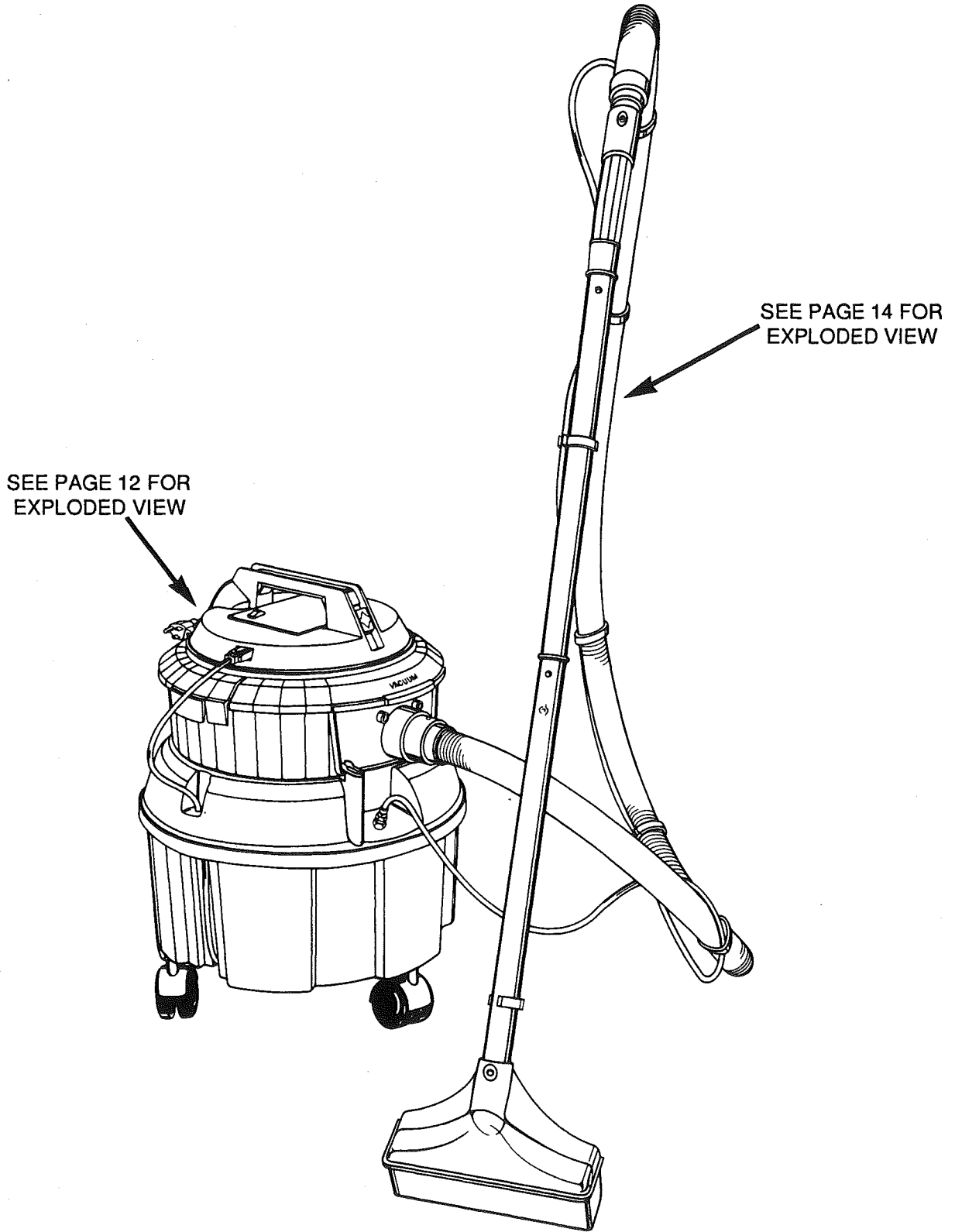

# SEARS HOME CLEANING SYSTEM — MODEL 175.8579280

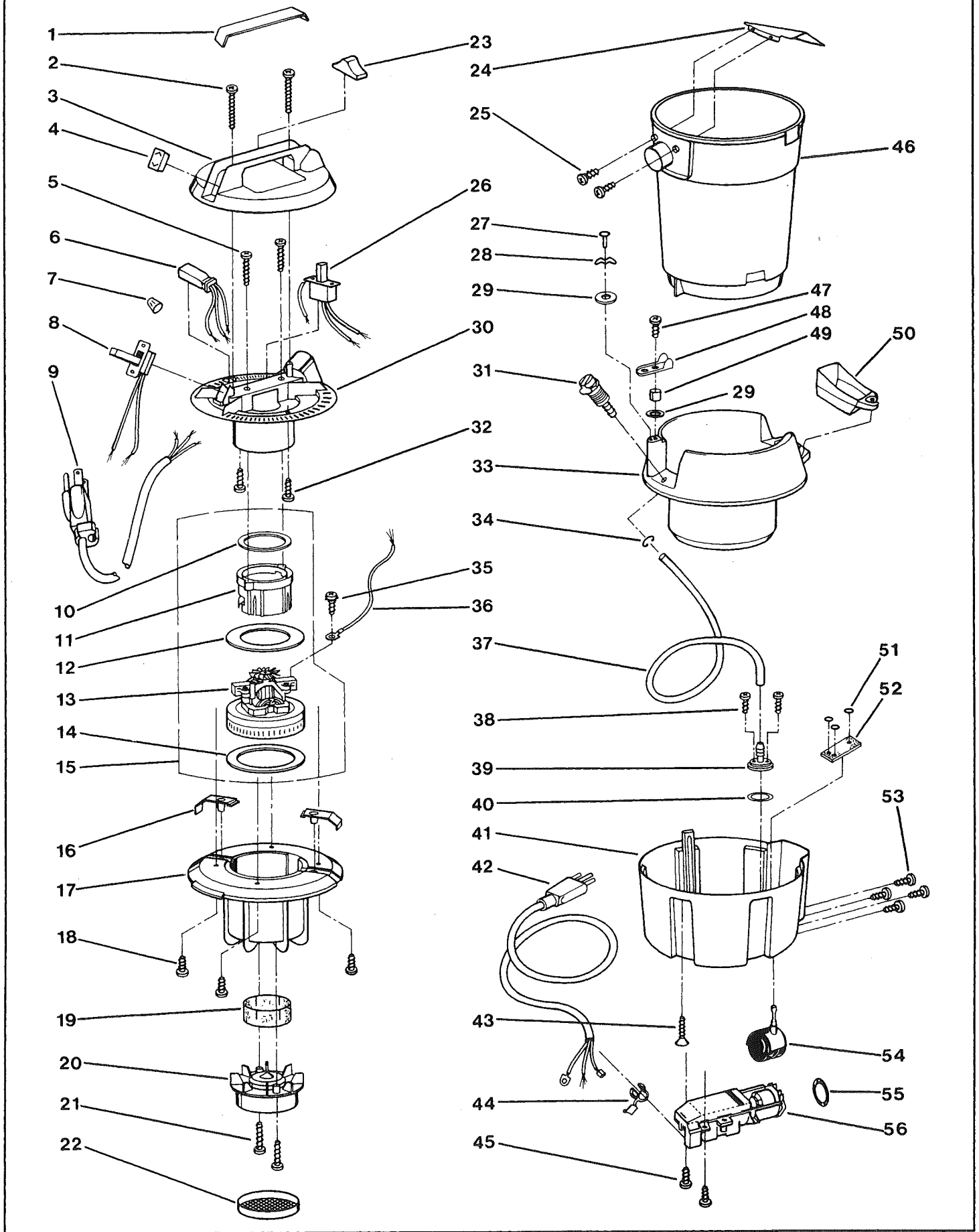

## SEARS HOME CLEANING SYSTEM — MODEL 175.8579280

KEY	PART NO.	DESCRIPTION
1	644147-003	Handle Plate
2	642337-002	Handle Screws (2)
3	642338-042	Handle Shroud w/Label
4	642315-011	Switch Cap
5	641798-003	Motor Housing Screws (2)
6	643492-005	Female Pigtail
7	642149-001	Wiring Nut
8	643509-001	Switch
9	641843-013	Power Cord
10	642367-006	Motor Seal
11	644548-004	Motor Cover
12	642367-004	Motor Seal
13	643909-902	Carbon Brush Asm.
14	642367-004	Motor Seal
15	642406-019	Motor Asm. Complete
16	641857-010	Latch (2)
17	641866-036	Cover Asm. w/ # 19, 20, 21, 22
18	642409-002	Cover Screws (4)
19	643584-000	Foam Filter
20	642405-001	Valve Asm. w/ #21, 22
21	643579-002	Valve Screws (2)
22	642313-000	Sensor Guard
23	642713-001	Pump Switch Cap
24	642447-000	Baffle
25	642409-002	Baffle Screws (2)
26	644846-001	Two Speed Switch - Pump w/Swithch Cap
27	642470-006	Rivet
28	640218-005	Wave Washer
29	706382-319	Washer (2)
30	642339-049	Separator Plate w/Key #8
31	644773-010	Coupling Body
32	640145-005	Separator Plate Screws (2)
33	643565-013	Upper Container w/ Filler Door
34	643561-000	Retaining Ring
35	644802-001	Ground Lead Screw
36	642392-003	Lead w/ terminal
37	643562-005	Tubing Asm. w/ #39, 34
38	643535-001	Valve Seat Screws (2)
39	643438-005	Valve Seat
40	643536-000	Gasket
41	643566-013	Lower Container
42	643531-007	Pigtail
43	643533-002	Lower Container Screws (3)
44	888493-304	Strain Relief
45	643685-001	Motor Screws (2)
46	642046-014	Dirt Container w/Baffle and Screws
47	989629-002	Latch Screw
48	660081-002	Latch
49	640940-001	Spacer
50	643431-008	Filler Door
51	643454-003	Washers (3)
52	643583-000	Foam Filter
53	643685-001	Motor Screws (4)
54	661393-001	Casters (3)
55	643171-003	"O" Ring Gasket
56	644089-012	Pump Motor

# SEARS HOME CLEANING SYSTEM — MODEL 175.8579280

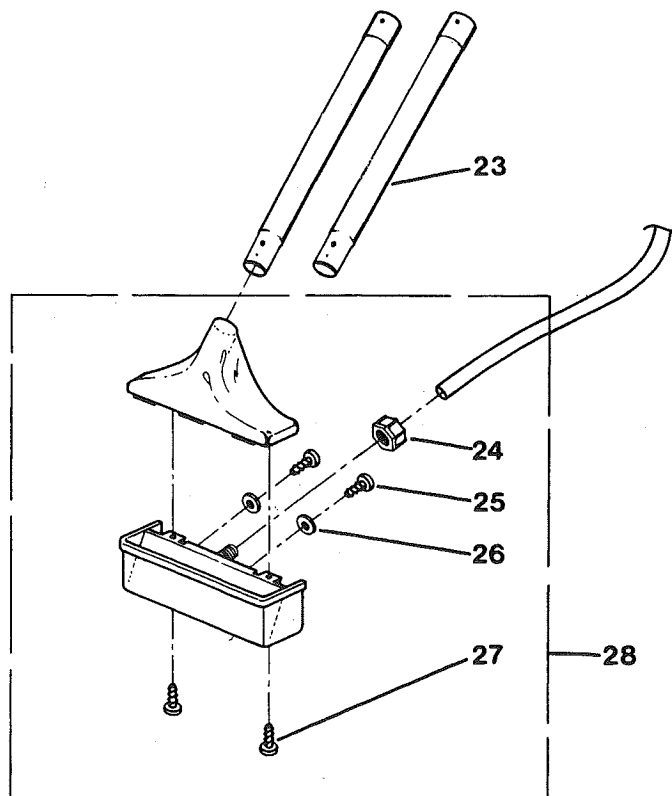
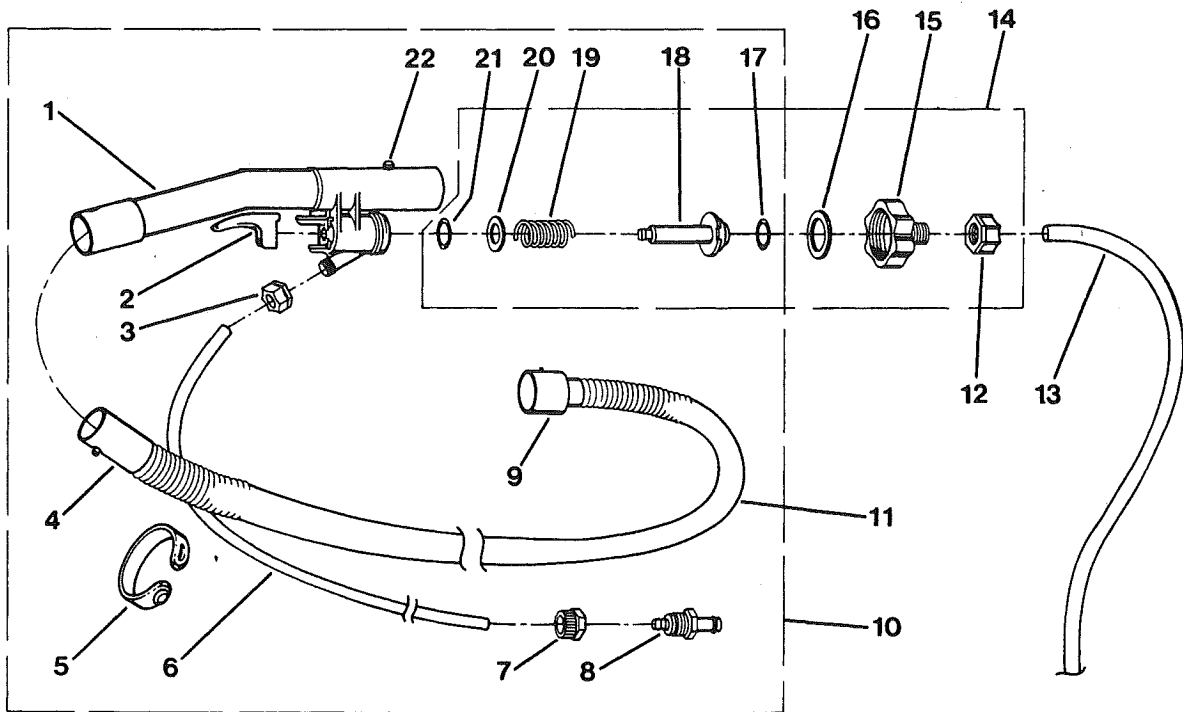

# SEARS HOME CLEANING SYSTEM — MODEL 175.8579280

KEY	PART NO.	DESCRIPTION
1	644153-008	Angled Wand
2	644152-004	Trigger
3	644037-003	Ferrule Nut
4	644156-005	Swivel Connector 1 - 1/4" dia.
5	643731-007	Tubing Strap
6	644038-003	Tubing - Hose
7	644773-005	Coupling Insert Nut
8	644773-009	Coupling Insert
9	644157-005	Swivel Connector 2 - 1/2 " dia.
10	643570-019	Hose and Angled Wand Asm.
11	644163-007	8' Hose
12	644037-003	Ferrule Nut
13	644038-001	Tubing - to Nozzle
14	643572-006	Valve Asm. Kit w/trigger
15	644162-003	Nut
16	643446-000	Neoprene Washer
17	643171-002	"O" Ring
18	644151-003	Sleeve
19	643444-000	Spring Valve
20	643445-000	Washer - Stainless Steel
21	643171-002	"O" Ring
22	644830-003	Lock Button
23	643186-018	Straight Wands (2)
24	644037-003	Ferrule Nut
25	640145-007	Screw (2)
26	643454-002	Neoprene Washer
27	643526-002	Screw (2)
28	643571-009	Nozzle Asm. Complete w/ Key # 12,13, 15, 16
	660850-172	Owner's Manual

# SEARS

OWNERS  
MANUAL

SERVICE

MODEL NO.  
175.8579280

HOW TO ORDER  
REPAIR PARTS

# Kenmore

## HOME CLEANING SYSTEM

Now that you have purchased your Kenmore Home Cleaning System, should a need ever exist for repair parts or service, simply contact any Sears Service Center. Be sure to provide all pertinent facts when you call or visit.

The **model number** of your Kenmore Home Cleaning System will be located under the handle.

WHEN ORDERING REPAIR PARTS, ALWAYS GIVE THE FOLLOWING INFORMATION:

- |                               |                                                     |
|-------------------------------|-----------------------------------------------------|
| • PART NUMBER                 | • PART DESCRIPTION                                  |
| • MODEL NUMBER<br>175.8579280 | • NAME OF ITEM<br>Cleanmore Home Cleaning<br>System |

All parts listed may be ordered from any Sears Service Center.

If the parts you need are not stocked locally, your order will be electronically transmitted to a Sears Repair Parts Distribution Center for handling.