

SEARS

CRAFTSMAN®

Operator's Guide

WIRE FEED MIG WELDER

Model No.
934.205592

- WARRANTY
- INTRODUCTION
- SAFETY SUMMARY
- SPECIFICATIONS
- INSTALLATION
- OPERATION
- MAINTENANCE
- SCHEMATIC
- WIRING DIAGRAM
- REPLACEMENT PARTS

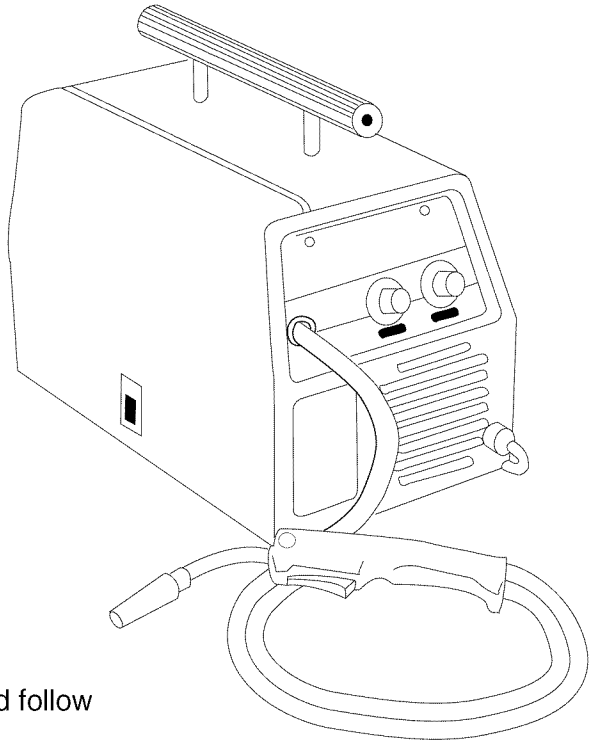

CAUTION: Read and follow all Safety Rules and Operating Instructions before First Use of this Product.

Sears, Roebuck and Co., Hoffman Estates, IL 60179 USA

CRAFTSMAN FULL WARRANTY

On Welding Gun or Cables, Welder, and Welder's Transformer

Full One Year Warranty for Craftsman Welding Gun or Cables. For one year from the date of purchase, when the welding gun or cables are operated and maintained according to the owner's manual instructions, if the welding gun or cables fail due to a defect in material or workmanship, Sears will repair or replace the welding gun or cables free of charge. This warranty does not cover parts consumed in normal operation, such as contact tips, nozzles, gun liners, and drive rollers.

Full Three Year Warranty on Craftsman Welder For three years from the date of purchase, when the welder is operated and maintained according to the owner's manual instructions, if the welder fails due to a defect in material or workmanship, Sears will repair or replace the welder free of charge. This warranty does not cover the welding gun, cables, or normal consumable parts.

WARRANTY SERVICE IS AVAILABLE BY SIMPLY CONTACTING THE NEAREST SEARS SERVICE CENTER.

This warranty applies only while this product is in use in the United States.

This warranty gives you specific legal rights, and you may also have other rights which vary from state to state.

Sears Roebuck and Co., Dept. 817WA,
Hoffman Estates, IL 60179.

TABLE OF CONTENTS

CRAFTSMAN FULL WARRANTY	2
TABLE OF CONTENTS	3
INTRODUCTION	4
SAFETY SUMMARY	5
SAFETY INFORMATION	5
SHOCK HAZARDS	6
FIRE HAZARDS	6
FLASH HAZARDS	6
FUME HAZARDS	6
COMPRESSED GASSES AND EQUIPMENT HAZARDS	6
BURN HAZARDS	7
ADDITIONAL SAFETY INFORMATION	7
WELDER SPECIFICATIONS	8
DESCRIPTION	8
WELDER OPERATING CHARACTERISTICS	8
DUTY CYCLE	8
INTERNAL THERMAL PROTECTION	8
WELDER INSTALLATION	9
POWER SOURCE CONNECTION	9
POWER REQUIREMENTS	9
CONNECT TO POWER SOURCE	9
EXTENSION CORDS	9
ASSEMBLING THE WELDER	9
UNPACKING THE WELDER	9
INSTALL THE GROUND CLAMP	9
INSTALL THE TANK TRAY AND BRACKET	9
INSTALL THE SHIELDING GAS	10
CHECK THE GAS FLOW	11
ALIGN AND SET THE DRIVE ROLLER	11
STANDARD DRIVE ROLLER	11
INSTALL THE WELDING WIRE	12
SET THE WIRE DRIVE TENSION	14
PREPARATION	15
CHANGE POLARITY	15
OPERATION	16
CONTROLS AND INDICATORS	16
MAINTENANCE	17
GENERAL	17
REPLACE A GUN LINER	17
MAINTAINING THE CONTACT TIP	20
MAINTAINING THE NOZZLE	20
TESTING FOR A SHORTED NOZZLE	21
PREVENTIVE MAINTENANCE	21
TROUBLESHOOTING	21
WIRING DIAGRAM	23
REPLACEMENT PARTS LIST	24
SCHEMATIC	26

INTRODUCTION

This Welder User's Guide provides specific information about your wire feed welder. It is to be used together with the Welding Instruction Guide to provide all of the information needed to safely and effectively use your wire feed welder. The information in this book applies to your specific model of wire feed welder and gives instruction on set-up, installation, and actual use of the welder.

Where information is shown that does not necessarily apply to all models or brands of welder, it will be marked as either optional on some welder models or *does not apply to all models*.

Optional on some welder models

SAFETY SUMMARY

Every craftsman respects the tools with which they work. They know that the tools represent years of constantly improved designs and developments. The true craftsman also knows that tools are dangerous if misused or abused.

Reading this Operator's Guide and the Welding Instruction Guide before using the welder will enable you to do a better, safer job. Learn the welder's applications and limitations as well as the specific potential hazards peculiar to welding.

SAFETY INFORMATION

The following safety information is provided as guidelines to help you operate your new welder under the safest possible conditions. Any equipment that uses electrical power can be potentially dangerous to use when safety or safe handling instructions are not known or not followed. The following safety information is provided to give you the information necessary for safe use and operation.

When a procedure step is preceded by a **WARNING**, it is an indication that the step contains a procedure that might be injurious to a person if proper safety precautions are not heeded.

When a procedure step is preceded by a **CAUTION**, it is an indication that the step contains a procedure that might damage the equipment being used.

A **NOTE** may be used before or after a procedure step to highlight or explain something in that step.

READ ALL SAFETY INSTRUCTIONS CAREFULLY before attempting to install, operate, or service this welder. Failure to comply with these instructions could result in personal injury and/or property damage.

RETAIN THESE INSTRUCTIONS FOR FUTURE REFERENCE.

Note: The following safety alert

symbols identify important safety messages in this manual.

When you see one of the symbols shown here, be alert to the possibility of personal injury and carefully read the message that follows.



This symbol indicates that the possibility of electric shock hazard exists during the operation of the step(s) that follow.



This symbol indicates that the possibility of fire hazard exists during the operation of the step(s) that follow.



This symbol indicates that the helmet must be worn during the step(s) that follow to protect against eye damage and burns due to flash hazard.



This symbol indicates that the possibility of toxic gas hazard exists during operation of the step(s) that follow.



This symbol indicates that the possibility of being burned by hot slag exists during operation of the step(s) that follow.



This symbol indicates that the eye protection should be worn to protect against flying debris in the following step(s).



This symbol indicates that the possibility of injury or death exists due to improper handling and maintenance of compressed gas cylinders or regulators.

Full explanations of the specific hazards are shown in the WELDING INSTRUCTION GUIDE. Make sure you have read and understand all of the

information before proceeding with any of the instructions contained in this user's guide.

Published standards on safety are available. They are listed in **ADDITIONAL SAFETY INFORMATION** at the end of this **SAFETY SUMMARY**.

The National Electrical Code, Occupational Safety and Health Act regulations, local industrial codes and local inspection requirements also provide a basis for equipment installation, use, and service.

SHOCK HAZARDS



WARNING

ELECTRIC SHOCK CAN KILL! To reduce the risk of death or serious injury from shock, read, understand, and follow the following safety instructions. In addition, make certain that anyone else who uses this welding equipment, or who is a bystander in the welding area understands and follows these safety instructions as well.

FIRE HAZARDS



WARNING

FIRE OR EXPLOSION CAN CAUSE DEATH, INJURY, AND PROPERTY DAMAGE! To reduce risk of death, injury, or property damage from fire or explosion, read, understand, and follow the following safety instructions. In addition, make certain that anyone else that uses this welding equipment, or is a bystander in the welding area, understands and follows these safety instructions as well. **REMEMBER!** Welding by nature produces sparks, hot spatter, molten metal drops, hot slag, and hot metal parts that can start fires, burn skin, and damage eyes.

FLASH HAZARDS

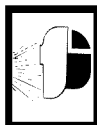

WARNING

ARC RAYS CAN INJURE EYES AND BURN SKIN! To reduce risk of injury from arc rays, read, understand, and follow the following safety instructions. In addition, make certain that anyone else that uses this welding equipment, or is a bystander in the welding area, understands and follows these safety instructions as well.

FUME HAZARDS



WARNING

FUMES, GASSES, AND VAPORS CAN CAUSE DISCOMFORT, ILLNESS, AND DEATH! To reduce risk of discomfort, illness, or death, read, understand, and follow the following safety instructions. In addition, make certain that anyone else that uses this welding equipment or is a bystander in the welding area, understands and follows these safety instructions as well.

COMPRESSED GASSES AND EQUIPMENT HAZARDS



WARNING

IMPROPER HANDLING AND MAINTENANCE OF COMPRESSED GAS CYLINDERS AND REGULATORS CAN RESULT IN SERIOUS INJURY OR DEATH! To reduce risk of injury or death from compressed gasses and equipment hazards, read understand and follow the following safety instructions. In addition, make certain that anyone else who uses this welding

equipment or a bystander in the welding area understands and follows these safety instructions as well.

Do not use flammable gasses with MIG welders. Only inert or nonflammable gasses are suitable for MIG welding. Examples are Carbon Dioxide, Argon, Helium, etc. or mixtures of more than one of these gasses.

BURN HAZARDS



WARNING

Hot slag can cause fires and serious injury from burns. To reduce the risk of discomfort or serious injury due to burns always wear heavy protective clothing, eye and face protection, and gloves designed for welding. To prevent the risk of fires starting, use a metal plate or some other material with a high flash point to catch and shield combustibles from the hot slag.

ADDITIONAL SAFETY INFORMATION

For additional information concerning welding safety, refer to the following standards and comply with them as applicable.

- ANSI Standard Z87.1 — SAFE PRACTICE FOR OCCUPATION AND EDUCATIONAL EYE AND FACE PROTECTION — obtainable from the American National Standards Institute, 11 West 42nd St., New York, NY 10036 Telephone (212) 642-4900, Fax (212) 398-0023 — www.ansi.org
- NFPA Standard 51B — CUTTING AND WELDING PROCESS — obtainable from the National Fire Protection Association, 1 Batterymarch Park, P.O. Box 9101, Quincy, MA 02269-9101 Telephone (617) 770-3000, Fax (617) 770-0700 — www.nfpa.org
- CGA Pamphlet P-I — SAFE HANDLING OF COMPRESSED GASSES IN CYLINDERS — obtainable from the Compressed Gas Association, 1725 Jefferson Davis Highway, Suite 1004, Arlington, VA 22202-4102 Telephone (703) 412-0900 Fax (703) 412-0128 — www.cagnet.com
- OSHA Standard 29 CFR, Part 1910, Subpart Q., WELDING, CUTTING AND BRAZING — obtainable from your state OSHA office or U. S. Dept. of Labor OSHA, Office of Public Affairs, Room N3647, 200 Constitution Ave. Washington, DC 20210 — www.osha.gov
- CSA Standard W117.2 — Code for SAFETY IN WELDING AND CUTTING. — obtainable from Canadian Standards Association, 178 Rexdale Blvd. Etobicoke, Ontario M9W 1R3 — www.csa.ca
- American Welding Society Standard A6.0. WELDING AND CUTTING CONTAINERS WHICH HAVE HELD COMBUSTIBLES. — obtainable from the American Welding Society, 550 NW Le Jeune Road, Miami, FL 33126 Telephone (800) 443-9353, Fax (305) 443-7559 — www.amweld.org or www.aws.org

WELDER SPECIFICATIONS

DESCRIPTION

Your new wire feed welder is designed for maintenance and sheet metal fabrication. The welder consists of a single-phase power transformer, stabilizer, rectifier, and a unique built-in control/feeder. This MIG welder is capable of welding with 0.024 (0.6mm) and 0.030 (0.8mm), solid steel wire on dc reverse polarity and with .030 inch self-shielding flux-core wire on dc straight polarity. Larger, 0.035 inch (0.9mm) diameter solid steel wire, on dc reverse polarity, and self shielding flux-core wire on dc straight polarity may also be used on this welder. The use of larger diameter wire makes welding difficult and the results cannot be guaranteed. The manufacturer does not recommend the use of larger diameter wire.

Now you can weld sheet metal from 24 gauge up to 1/4 inch thick with a single pass. You can weld thicker steel with beveling and multiple pass techniques. Table 1 lists your MIG welder specifications.

Table 1. Welder Specifications

Primary (input) volts	120 Vac
Primary (inputs) Amps	25
Phase	Single
Frequency	60 Hz
Secondary (output) volts	19.5
Secondary (UL output) amps	105
Open Circuit Volts (Max.)	28 Vdc
Duty Cycle Rating	20%

WELDER OPERATING CHARACTERISTICS

DUTY CYCLE

The duty cycle rating of a welder defines how long the operator can weld and how long the welder must be rested and cooled. Duty cycle is expressed as a percentage of 10 minutes and represents the maximum welding time

allowed. The balance of the 10-minute cycle is required for cooling.

Your new welder has a duty cycle rating of 20% at the rated output. This means that you can weld for two (2) minutes out of 10 with the remaining eight (8) minutes required for cooling. (See Table 2).

Table 2. Duty Cycle Ratings

Duty Cycle Rating	Maximum Welding Time	Required Resting Time
20%	2 minutes	8 minutes
40%	4 minutes	6 minutes
60%	6 minutes	4 minutes
80%	8 minutes	2 minutes
100%	10 minutes	0 minutes

INTERNAL THERMAL PROTECTION

CAUTION

Do not constantly exceed the duty cycle or damage to this welder can result. If you exceed the duty cycle of your welder, an internal thermal protector will open, shutting off all welder functions except the cooling fan. If this happens, **DO NOT SHUT OFF THE WELDER.** Leave the welder turned on with the fan running. After cooling, the thermal protector will automatically reset and the welder will function normally again. However, you should wait at least 10 minutes after the thermal protector opens before resuming welding. You must do this even if the thermal protector resets itself before the 10 minutes is up or you may experience less than specified duty cycle performance.

If you find that your welder will not weld for 2 minutes without stopping, reduce the wire speed slightly and tune the welder in at the lowest wire speed setting that still produces a smooth arc. Welding with the wire speed set too high causes excessive current draw and shortens the duty cycle.

WELDER INSTALLATION

POWER SOURCE CONNECTION

POWER REQUIREMENTS

This welder is designed to operate on a properly grounded 120 Volt, 60 Hz, single-phase alternating current (ac) power source fused with a 20 amp time-delayed fuse or circuit breaker. It is recommended that a qualified electrician verify the **ACTUAL VOLTAGE** at the receptacle into which the welder will be plugged and confirm that the receptacle is properly fused and grounded. The use of the proper circuit size can eliminate nuisance circuit breaker tripping when welding.

DO NOT OPERATE THIS WELDER if the ACTUAL power source voltage is less than 105 Volts ac or greater than 132 Volts ac. Contact a qualified electrician if this problem exists. Improper performance and/or damage to the welder will result if operated on inadequate or excessive power.

CONNECT TO POWER SOURCE



WARNING

High voltage danger from power source! Consult a qualified electrician for proper installation of receptacle at the power source.

This welder must be grounded while in use to protect the operator from electrical shock. If you are not sure if your outlet is properly grounded, have it checked by a qualified electrician. Do not cut off the grounding prong or alter the plug in any way and do not use any adapters between the welder's power cord and the power source receptacle.

Make sure the POWER switch is OFF then connect your welder's power cord to a properly grounded 120 Vac, 60 Hz, single phase, 20 amp power source.

EXTENSION CORDS

For optimum welder performance, an extension cord should not be used unless absolutely necessary. If necessary, care must be taken in selecting an extension cord appropriate for use with your specific welder.

Select a properly grounded extension cord that will mate directly with the ac power source receptacle and the welder power cord without the use of adapters. Make certain that the extension is properly wired and in good electrical condition.

Extension cords must be at the smallest a #12 gauge cord. Do not use an extension cord over 25 ft. in length.

ASSEMBLING THE WELDER

The following procedures describe the process required to assemble, install, maintain, and prepare to weld with your new wire feed welder.

UNPACKING THE WELDER

1. Remove any cartons or bags containing parts/accessories.
2. Open the cartons or bags packed with your welder and inspect their contents for damage. Report any missing or damaged items immediately.
3. Grasp the top handle of the welder and lift the welder out of the carton.

INSTALL THE GROUND CLAMP

Connect the ground clamp to the ground cable (coming out the front of the welder) according to the instructions packaged with the ground clamp.

INSTALL THE TANK TRAY AND BRACKET

The tank tray bracket is installed on the back of the welder, see Figure 1.

IMPORTANT – GAS CYLINDER SIZE RESTRICTION! The tank tray you have just installed on the back of the welder will handle gas cylinders no larger than 20 cubic feet. If you select a cylinder larger than 20 cubic feet, it must be chained to a wall or other fixed support.

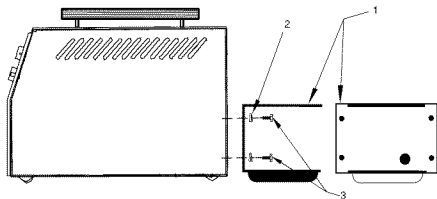

Figure 1. Mount Tank Tray Bracket To Welder

1. Align the four tank tray bracket (1) mounting holes (as shown in Figure 1) with the four staked nuts on the rear of the welder.
2. Start one ¼ inch split lock washer (2) and a ¼-20 x ½ inch hex bolt (3) in one of the top tank tray bracket (1) mounting holes, then start each of the other three split lock nuts (2) and ¼-20 x ½ inch hex bolts (3) through the remaining mounting holes.
3. Tighten all four hex bolts.

INSTALL THE SHIELDING GAS



WARNING

IMPROPER HANDLING AND MAINTENANCE OF COMPRESSED GAS CYLINDERS AND REGULATORS CAN RESULT IN SERIOUS INJURY OR DEATH! Always secure gas cylinders to the tank bracket kit, a wall, or other fixed support to prevent the cylinder from falling over and rupturing. Read, understand, and follow all the COMPRESSED GASSES AND EQUIPMENT HAZARDS in the SAFETY SUMMARY at the front of this manual.

Secure your gas cylinder to the tank bracket kit, a wall, or other fixed support.

1. Remove the protective cap from the cylinder and inspect the regulator connecting threads for dust, dirt oil, and grease. Remove any dust or dirt with a clean cloth. **DO NOT ATTACH THE REGULATOR IF OIL, GREASE, OR DAMAGE ARE PRESENT.**
2. Open the cylinder valve **FOR JUST AN INSTANT** to blow out any foreign matter inside the valve port to reduce the risk of plugging or damaging the regulator. Never aim the open cylinder valve port at yourself or bystanders.
3. Screw the regulator supplied with this welder (see Figure 2) into the cylinder valve and tighten with a wrench.

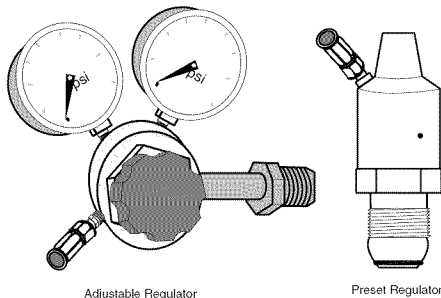

Adjustable Regulator

Preset Regulator

Figure 2. Gas Regulators

4. Insert the gas hose into the outlet port of the gas regulator. The hose locks in place in the fitting when pressed into the port.
5. To remove the gas hose, press down on the ring at the rear of the gas fitting, and pull the hose out of the fitting.

CHECK THE GAS FLOW



WARNING

IMPROPER HANDLING AND MAINTENANCE OF COMPRESSED GAS CYLINDERS AND REGULATORS CAN RESULT IN SERIOUS INJURY OR DEATH!

To reduce the risk of injury or death, always stand to the side of the cylinder opposite the regulator when opening the cylinder valve, keeping the cylinder valve between you and the regulator. Never aim the open cylinder valve port at yourself or bystanders. Failure to comply with this warning could result in serious personal injury.

Note: If the cylinder you have is equipped with male regulator connecting threads instead of female, you will need to obtain a special compressed gas cylinder adapter from your gas supplier to install between your gas cylinder and regulator.

- The gas control function does not require the welder to be turned on or plugged in.
1. Slowly crack open the cylinder valve, then turn open **ALL THE WAY**.
 2. Pull the trigger on the gun to allow the gas to flow. **KEEP THE TRIGGER PULLED**. Listen and feel for gas flowing from the end of the welding gun. If your regulator has no adjustment, it has been pre-set at the factory for a flow of 20 cubic feet per hour. If your gas regulator has an adjustment to control the gas flow rate, turn the adjustment key clockwise to increase gas flow; counterclockwise to reduce flow. For most welding, the gas flow should be set at 15-20 cubic feet per hour. If no gas is heard or felt, verify all steps involved in connecting the gas.

3. Release the trigger.

Note: If welding outside or in a draft, it may become necessary to set up a windbreak to keep the shielding gas from being blown from the weld area.

- **MAKE SURE TO TURN OFF THE GAS CYLINDER VALVE WHEN DONE WELDING.**

ALIGN AND SET THE DRIVE ROLLER

Before installing any welding wire into the unit, the proper sized groove must be placed into position on the wire drive mechanism. Change to a neoprene drive roller when welding with aluminum wire.

STANDARD DRIVE ROLLER

Change the standard drive roller according to the following steps:

1. Remove the drive tension by unscrewing the tension adjusting screw (**ALL THE WAY** in a counter-clockwise direction). The drive tension screw will come loose, allowing you to pull the drive tension arm up away from the drive roller. Make sure to keep the screw and the spring in place with the drive tension arm.
2. If there is wire already installed in the welder, roll it back onto the wire spool by hand-turning the spool counter-clockwise. Be careful not to allow the wire to come out of the rear end of the gun without holding onto it or it will unspool itself. Put the end of the wire into the hole on the outside edge of the wire spool and bend it over to hold the wire in place. Remove the spool of wire from the welder.
3. Loosen the drive roller setscrew and pull the drive roller off the drive shaft.

Note: The drive roller has two wire size grooves built into it. When installing the drive roller the number stamped on the drive roller for the wire size you are using should be facing away from you. If you can read the wire size you are using on the drive roller, it is installed backwards. Use only the proper size drive roller when using your welder.

4. Find the side of the drive roller that is stamped with the same wire diameter as that of the wire being installed (see Figure 3, and if in metric, see DESCRIPTION in the WELDER SPECIFICATIONS section). Make certain the spacing washer is still on the motor shaft and push the drive roller onto the motor shaft, aligning the setscrew with the flat side of the drive shaft. Make sure the side stamped with the desired wire diameter is away from you.

Drive Roller

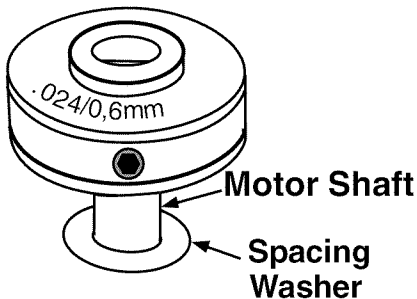

Figure 3. Drive Roller

5. Slide the roller onto the shaft so that the groove in the roller lines up with the inlet tube and the welding gun liner. You can look at the alignment from the top of the welder.

6. Tighten the setscrew, while holding the drive roller in place.

INSTALL THE WELDING WIRE



WARNING

Electric shock can kill! Always turn the POWER switch OFF and unplug the power cord from the ac power source before installing wire.

Be very careful when removing the welding nozzle. The contact tip on this welder is electrically hot as long as POWER is turned ON. Make certain POWER is turned OFF.

1. Remove the nozzle and contact tip from the end of the gun assembly.
2. Make sure the proper groove on the drive roller is in place for the wire being installed. If the proper groove is not in place, change the drive roller as described above.
3. Unwrap the spool of wire then find the leading end of the wire (it goes through a hole in the outer edge of the spool and is bent over the spool edge to prevent the wire from unspooling) BUT DO NOT UNHOOK IT YET.
4. Place the spool on the spindle in such a manner that when the wire comes off the spool, it will look like the top illustration in Figure 4. The welding wire should always come off the top of the spool into the drive mechanism.

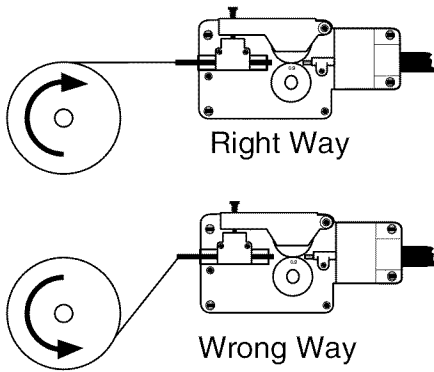

Figure 4. Right and Wrong Way To Feed Wire From Spool

5. If you are installing a four-inch spool of wire, install the drive brake hardware on the top of the spool of wire according to Figure 5A. If you are installing an eight-inch spool, install the spindle adapter and drive brake hardware as shown in Figure 5B. The purpose of the drive brake is to cause the spool of wire to stop turning at nearly the same moment that wire feeding stops.
6. Once the drive brake hardware is installed, set the spool tension. With one hand, turn the wire spool and continue turning it while adjusting the tension on the spool. With your free hand, tighten (turn clockwise) the wing nut that holds the spool in place. Stop tightening when drag is felt on the wire spool that you are turning, then stop hand turning the wire spool.

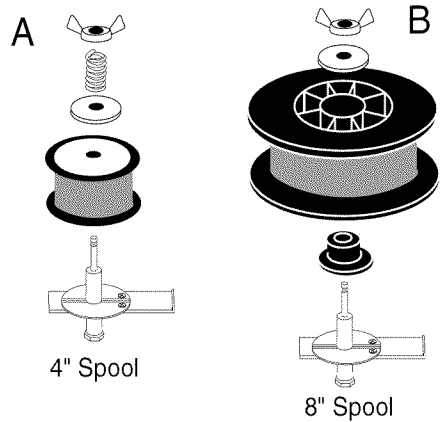

Figure 5. Drive Brake Assemblies with Four Inch and Eight Inch Wire Spools

- Note:** If TOO MUCH tension is applied to the wire spool, the wire will slip on the drive roller or will not be able to feed at all. If TOO LITTLE tension is applied, the spool of wire will want to unspool itself. Readjust the drive brake tension as necessary to correct for either problem.
7. After checking to make sure that your welder is disconnected from the ac power source, free the leading end of the wire from the spool, but do not let go of it until told to do so, or the wire will unspool itself.
 8. Using a wire cutter, cut the bent end off the leading end of the wire so that only a straight leading end remains.
 9. Loosen the tension adjusting screw holding the drive tension arm in place and lift the tension arm up off the drive roller.
 10. Insert the leading end of the wire into the inlet guide tube. Then push it across the drive roller and into the gun assembly about six inches.

CAUTION

Make certain that the welding wire is actually going into the gun liner. Be very sure it has not somehow been accidentally been routed alongside the liner or even in some other direction. If this should happen, the wire could feed inside the cable casing or take a right angle and follow the wires and gas hose inside the welder. It could also feed back on itself jamming up the mechanism.

11. Line the wire up in the inside groove of the drive roller, then allow the drive tension arm to drop onto the drive roller.
12. Tighten (turn clockwise) the drive tension adjusting screw until the tension roller is applying enough force on the wire to prevent it from slipping out of the drive assembly.
13. Let go of the wire.
14. Connect the welder power cord to the ac power source. Turn the welder POWER switch ON. Set the VOLTAGE switch to the voltage (heat) setting recommended for the gauge metal that is to be welded. Refer to the label mounted on the cover, inside the drive compartment, for recommended voltage (heat) settings for your welding job. The VOLTAGE selector controls the weld heat. There are eight voltage (heat) selections (numbered 1 through 8) available on this welder. Numbered position 1 provides the lowest voltage (heat) and position 8 the highest voltage (heat).
15. Set the WIRE SPEED control to the middle of the wire speed range.
16. Pull the trigger on the welding gun to feed the wire through the gun assembly.
17. When at least an inch of wire sticks out past the end of the gun, release the trigger.

18. Select a contact tip stamped with the same diameter as the wire being used. If stamped in metric, see DESCRIPTION.
19. Slide the contact tip over the wire (protruding from the end of the gun). Thread the contact tip into the end of the gun and hand-tighten securely.
20. Install the nozzle on the gun assembly. For best results, coat the inside of the nozzle with anti-stick spray or gel (part #4312, not supplied).
21. Cut off the excess wire that extends past the end of the nozzle.

SET THE WIRE DRIVE TENSION



WARNING

To reduce the risk of arc flash, make certain that the wire coming out of the end of the gun does not come in contact with the workpiece clamp or any grounded material during the drive tension setting process or arcing will occur.

1. Pull the trigger on the gun.
2. Turn the drive tension adjustment knob clockwise, increasing the drive tension until the wire seems to feed smoothly without slipping.
3. Block the end of the nozzle by holding it up against something that doesn't conduct electricity, such as a block of wood or a concrete floor, then trigger the gun again. The wire should slip at the drive roller. However, if the wire bird-nests at the drive roller, rethread the drive system using less drive tension and try again.

- When the drive tension is set correctly, there should be no slippage between the wire and the drive roller. However, if an obstruction occurs along the wire feed path, the wire should then slip on the drive roller.

PREPARATION

CHANGE POLARITY

This welder allows you the capability to change the welding current polarity. You may select either dc Straight (dc – Flux Cored) or dc Reverse Polarity (dc + MIG). For welding steel with solid wire, stainless steel, flux cored hardfacing of steel, and silicon bronze welding of steel, select dc Reverse Polarity (dc + MIG). When using self-shielding, flux-core steel wire, use dc Straight Polarity (dc – Flux Cored).

Change the polarity of your welder according to the following procedure steps. Figure 8 shows what the polarity block should look like for each polarity setting.



WARNING

Electric shock can kill! Always turn the POWER switch OFF and unplug the power cord from the ac power source before changing polarity.

CAUTION

Do not use a ratchet, crescent or other lever type wrench to tighten the nuts on the polarity bus. The nuts must be hand tightened with a 7/16 inch nut driver only. Too much torque applied to the one of the nuts could cause the threaded post to break off.

Tools Required:

- 7/16 inch nut driver
- With a 7/16 inch nut driver, remove all four nuts and pull out the vertically mounted copper straps.
 - Replace the copper straps horizontally in the dc Straight Polarity (dc – Flux Cored) configuration shown in Figure 6.

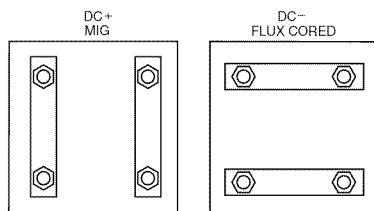

Figure 6. Welder Polarity Selections

- Start the four nuts on the four connecting posts and hand snug each nut with the 7/16 nut driver. Do not use a ratchet, crescent or other lever type wrench.

OPERATION

Operation of this welder consists of selecting and adjusting operating controls for optimum voltage (welding heat) and wire speed settings.

CONTROLS AND INDICATORS



WARNING

Electric shock can kill! To remove the risk of electric shock, be aware that the VOLTAGE selector, when OFF, does not remove power from all internal circuitry in the welder.

POWER – This welder has a POWER switch mounted on the front panel. The POWER switch is used to initiate (turn the welder ON) or extinguish (turn the welder OFF) ac power to the welder.

VOLTAGE SELECTOR – The voltage selector controls the welding heat. The voltage selector provides continuous voltage (heat) adjustment but has reference number settings 1–8. Number 1 is the lowest voltage (heat) setting and number 8 the highest. Refer to the label under the welder hood for recommended voltage (heat) settings for your welding job.

WIRE SPEED CONTROL – The WIRE SPEED CONTROL adjusts the speed at which the wire is fed out of the welding gun. The wire speed needs to be closely matched (tuned-in) to the rate at which it is being melted off (see TUNING IN THE WIRE SPEED, (in the Welding Instruction Guide). Some things that affect wire speed selection are the type and diameter of the wire being used, the heat setting selected, and the welding position to be used.

MAINTENANCE

GENERAL

This welder has been engineered to give many years of trouble-free service providing that a few very simple steps are taken to properly maintain it.

1. Keep the wire drive compartment lid closed at all times unless the wire needs to be changed or the drive tension needs adjusting.
2. Keep all consumables (contact tips, nozzles, and gun liner) clean and replace when necessary. See **CONSUMABLE MAINTENANCE AND TROUBLESHOOTING** later in this section for detailed information.
3. Replace power cord, ground cable, ground clamp, or gun assembly when damaged or worn.
4. Periodically clean dust, dirt, grease, etc. from your welder. Every six months or as necessary, remove the side panels from the welder and air-blow any dust and dirt that may have accumulated inside the welder.



WARNING

ELECTRIC SHOCK CAN KILL! To reduce the risk of electric shock, always unplug the welder from its ac power source before removing side panels.

IT IS VERY IMPORTANT TO MAINTAIN THE CONSUMABLES TO AVOID THE NEED FOR PREMATURE REPLACEMENT OF THE GUN ASSEMBLY.

The **GUN LINER** is intended to provide an unrestricted path for the welding wire to flow through the gun assembly. Over time it will accumulate dust, dirt, and other debris. Replacement is necessary when these accumulations begin to restrict the free flow of wire through the gun assembly.

REPLACE A GUN LINER

When removing or installing a gun liner, care must be taken not to kink or otherwise damage the gun liner or replacement will be necessary. See Figure 7 for the drive assembly and Figure 8 for the gun assembly.

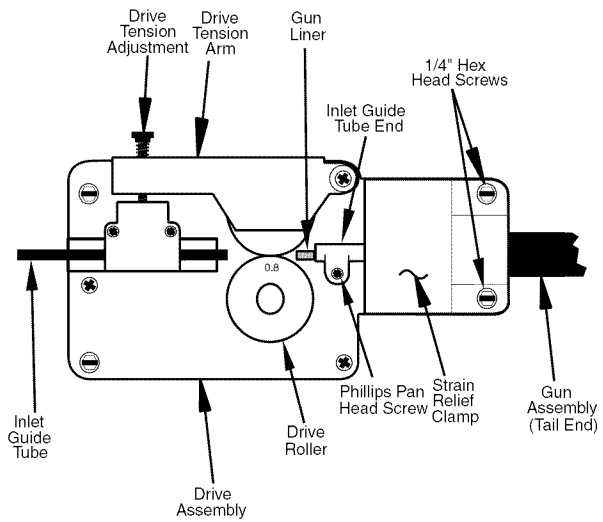

Figure 7. Drive Assembly

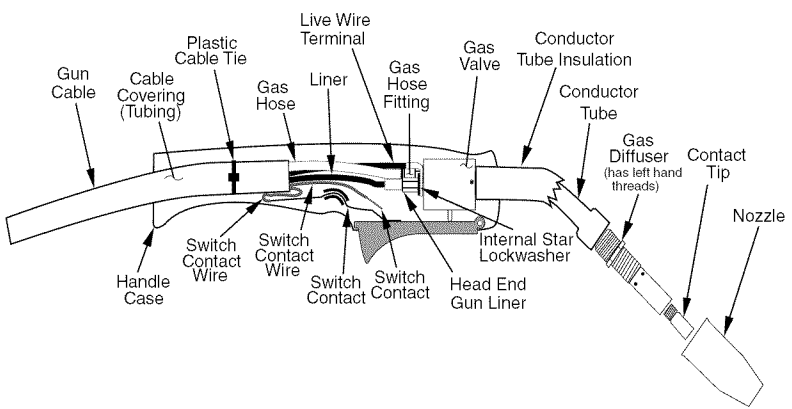

Figure 8. Gun Assembly

Tools Required:

- 5/16 inch open end wrench
 - Crescent Wrench (6 or 8 inch)
 - 9 mm open end wrench (or 3 inch crescent)
 - Phillips Screwdriver
 - Straight Blade Screwdriver or ¼ inch hex driver
1. Turn OFF welder POWER SWITCH.
 2. Open the welder side panel.
 3. Loosen the tension arm and lift it up off the drive roller.
 4. Turn the wire spool counter-clockwise (be sure to hold onto the wire itself while turning the spool or the wire will unspool itself when it becomes free of the gun liner), removing wire from gun assembly.
 5. Remove two ¼ inch hex head screws (may also be removed with a straight blade screwdriver) and one pan head Phillips screw (inlet guide tube end) from the drive roller and lift away the strain relief clamp that holds the tail end of the gun in the drive assembly.
 6. Leave the gun assembly (consists of nozzle, gas diffuser, conductor tube, handle and cable containing gas tubing electrical cable and liner) attached to the welder but move the welder to a place where the gun assembly can be laid out straight on a table or workbench or similar flat surface.
 7. Unscrew and remove the nozzle.
 8. With a crescent wrench (six or eight inch), turn the gas diffuser clockwise (has left hand threads) and remove the gas diffuser (and contact tip together) from the conductor tube on the end of the gun.
 9. Remove the four Phillips head screws that hold the handle case together. With the exception of the trigger, completely remove the contents of the handle case.

10. Cut the plastic cable tie away from the cable covering (tubing).

Note: In the following procedure step, it may be necessary to remove the gas fitting from the gas valve in order to make room to turn out the head end of the gun liner.

11. With a 5/16 inch open end wrench, unscrew the head end of the liner from the gas valve. Save the internal star lock-washer and note the orientation of the live wire terminal. If you find it necessary to remove the gas hose connector, press down on the ring at the rear of the gas fitting to release the gas hose and pull out the gas hose. Remove the gas fitting with a 9 mm open end wrench or three inch crescent.
12. Pull the liner out of the cable covering (tubing) from the handle end and push the small piece of liner out of the conductor tube.
13. Carefully insert the new liner into the cable taking particular care to keep the liner straight (especially at the terminal end) to ease its passage through cable covering. It may be desirable, perhaps even necessary, to apply some silicon grease to the outside of the new liner so that it will slide easily through the cable.
14. Insert the new piece of liner in the conductor tube.

Note: If you found it necessary to remove the gas and hose connector at step 9, remember to reconnect it after completing step 12. The gas hose can be reconnected by simply pushing it into the back of the connector.

15. Insert the head of the gun liner through the internal star lock washer and the live wire terminal (repeat the orientation noted in step 9). With a 5/16 inch open end wrench, screw the head end of the new liner into the gas valve.

16. Insert a new plastic cable tie in place around the cable and tighten it in approximately the same location as the plastic cable tie that was cut in step 8.
17. Return all components to the handle casing and realign them as they were originally.
18. With both halves of the handle case in place, tighten the four Phillips pan head screws making sure the trigger remains seated in place.
19. Push the cable into the welder far enough so that the end of the gun liner protrudes through the inlet guide tube end of the wire-feed torch clamp far enough so that it is within approximately 1/16 inch of touching the drive roller.
20. Make sure the cable covering (tubing) is far enough in the machine so that it is covered by the wire-feed torch clamp.
21. Tighten the two ¼ inch hex head screws (may also be tightened by a straight blade screwdriver) and one pan head Phillips screw to the drive roller securing the gun in place.
22. Re-install the welding wire according to **INSTALL THE WELDING WIRE**.

MAINTAINING THE CONTACT TIP

The purpose of the CONTACT TIP is to transfer welding current to the welding wire while allowing the wire to pass through it smoothly.

Always use a contact tip stamped with the same diameter as the wire it will be used with.

1. If the wire burns back into the tip, remove the tip from the gun and clean the hole running through it with an oxygen-acetylene torch tip cleaner or tip drill.

2. Over time, the hole in the contact tip will become worn by the wire passing through it. The more worn this hole becomes, the less efficient is the transfer of welding current to the wire and eventually arc breakage and difficult arc starting will result. Replace contact tips when signs of wear become apparent.

MAINTAINING THE NOZZLE

The nozzle directs the shielding gas to the weld puddle, determines the size of the shielding area, and prevents the electrically *hot* contact tip from contacting the work piece.

CAUTION

KEEP THE NOZZLE CLEAN! During the welding process, spatter and slag will build up inside the nozzle and must be cleaned out periodically. Failure to clean and/or replace the nozzle in a timely fashion **WILL CAUSE DAMAGE TO THE FRONT-END OF THE GUN ASSEMBLY**.

For best results, coat the inside of a new or freshly cleaned nozzle with anti-stick spray or gel.

1. Stop welding and clean any accumulated slag or spatter from the nozzle every 5 to 10 minutes of welding time.
2. When welding overhead, if any molten metal drips from the weld puddle and falls into the nozzle, **STOP WELDING IMMEDIATELY** and clean the nozzle.
3. If the slag cannot be thoroughly cleaned from the nozzle, **REPLACE THE NOZZLE!**

Failure to keep the nozzle adequately cleaned can result in the following problems:

A **SHORTED** nozzle results when spatter buildup bridges the insulation in the nozzle allowing welding current to flow through it as well as the contact tip. When shorted, a nozzle will steal welding current from the wire whenever it contacts the grounded work piece. This causes erratic welds and reduced penetration.

In addition, a shorted nozzle overheats the end of the gun, which can **DAMAGE** the front-end of the gun.

A **RESTRICTED** nozzle is created when enough slag builds up in the nozzle to affect the direction, concentration, and or rate of the shielding gas flow. This problem can cause porous, brittle welds and reduce penetration.

TESTING FOR A SHORTED NOZZLE

Arcing between the nozzle and the work piece **ALWAYS** means the nozzle is shorted, but this can be hard to detect through the lens of a welding helmet. The following testing method is another way to tell if a nozzle is shorted.

With the welder unplugged from the ac power source, touch the probes of an ohmmeter or continuity tester to the end of the contact tip and the outside of the nozzle. If there is any continuity at all, the nozzle **IS** shorted. Clean or replace as needed.

PREVENTIVE MAINTENANCE

Except for internal and external cleaning, cleaning the nozzle, and occasionally retightening screws, there is no periodic maintenance recommended for your welder.

TROUBLESHOOTING

The following **TROUBLESHOOTING** information is provided as a guide to help resolve some of the more common problems that could be encountered.

Table 3 is a troubleshooting table provided to help you determine a possible remedy when you are having a problem with your welder. This table does not provide all possible solutions, only those possibilities considered to likely be common faults. The table consists of a **TROUBLE** or symptom, a **POSSIBLE CAUSE** for that symptom, and a **POSSIBLE REMEDY** for that symptom.

Table 3. Troubleshooting

TROUBLE	POSSIBLE CAUSE	POSSIBLE REMEDY
Dirty, porous brittle weld	<ol style="list-style-type: none"> 1. Plugged welding nozzle 2. No shielding gas 3. Wrong Type of Gas 4. Dirty or rusty welding wire 	<ol style="list-style-type: none"> 1. Clean or replace nozzle 2. Tank empty, flow restricted, or regulator set too low 3. See SELECTING SHIELDING GAS in the WELDING INSTRUCTION GUIDE for proper selection 4. Replace spool of wire
Wire feed works but no arc	<ol style="list-style-type: none"> 1. Bad ground or loose connection 2. Bad connection to gun or faulty gun 	<ol style="list-style-type: none"> 1. Check ground and connections tighten as necessary 2. Check connection to gun or replace gun
Arc works but not feeding wire.	<ol style="list-style-type: none"> 1. Faulty wire speed control assembly 2. No tension on the drive roller 3. Faulty drive motor (very rare) 	<ol style="list-style-type: none"> 1. Replace wire speed control assembly 2. Adjust the drive tension 3. Replace drive motor
Nothing works except fan	<ol style="list-style-type: none"> 1. Faulty trigger on gun 2. Faulty transformer (rare) 3. Exceeded duty cycle; thermal protector opened 	<ol style="list-style-type: none"> 1. Replace trigger 2. Replace transformer 3. Allow welder to cool at least 10 minutes (observe and maintain proper duty cycle)
Low output or non-penetrating weld.	<ol style="list-style-type: none"> 1. Loose connection inside machine 2. Too long or improper extension cord 3. Wrong type or size wire 4. Poor ground connection 5. Wrong size contact tip 6. Loose gun connection or faulty gun assembly 7. Wrong welding polarity set 8. Dirty or rusty welding wire 	<ol style="list-style-type: none"> 1. Blow inside of machine out with compressed air, clean and tighten all connections 2. See EXTENSION CORD USE in this manual 3. Use correct size welding wire 4. Reposition clamp and check cable to clamp connection 5. Use correct size contact tip 6. Tighten gun or replace gun 7. Change polarity to proper for wire being used 8. Replace spool of wire
Wire is birdnesting at the drive roller	<ol style="list-style-type: none"> 1. Too much tension on drive roller 2. Gun liner worn or damaged 3. Contact tip is clogged or damaged 4. Liner is stretched or is too long 	<ol style="list-style-type: none"> 1. Adjust the drive tension (see INSTALLING THE WELDING WIRE) 2. Replace gun liner 3. Replace contact tip 4. Trim liner to proper length
Wire burns back to contact tip	<ol style="list-style-type: none"> 1. Gun liner is worn or damaged 2. Liner stretched or is too long 3. Wrong size contact tip 4. contact tip clogged or damaged 	<ol style="list-style-type: none"> 1. Replace gun liner 2. Trim liner for proper length 3. Use correct size contact tip 4. Replace contact tip
Ground clamp and/or cable gets hot	Bad connection from cable to clamp	Tighten connection or replace cable
Gun nozzle arcs to work surface	Slag buildup inside nozzle or nozzle is shorted	Clean or replace nozzle as needed

WIRING DIAGRAM

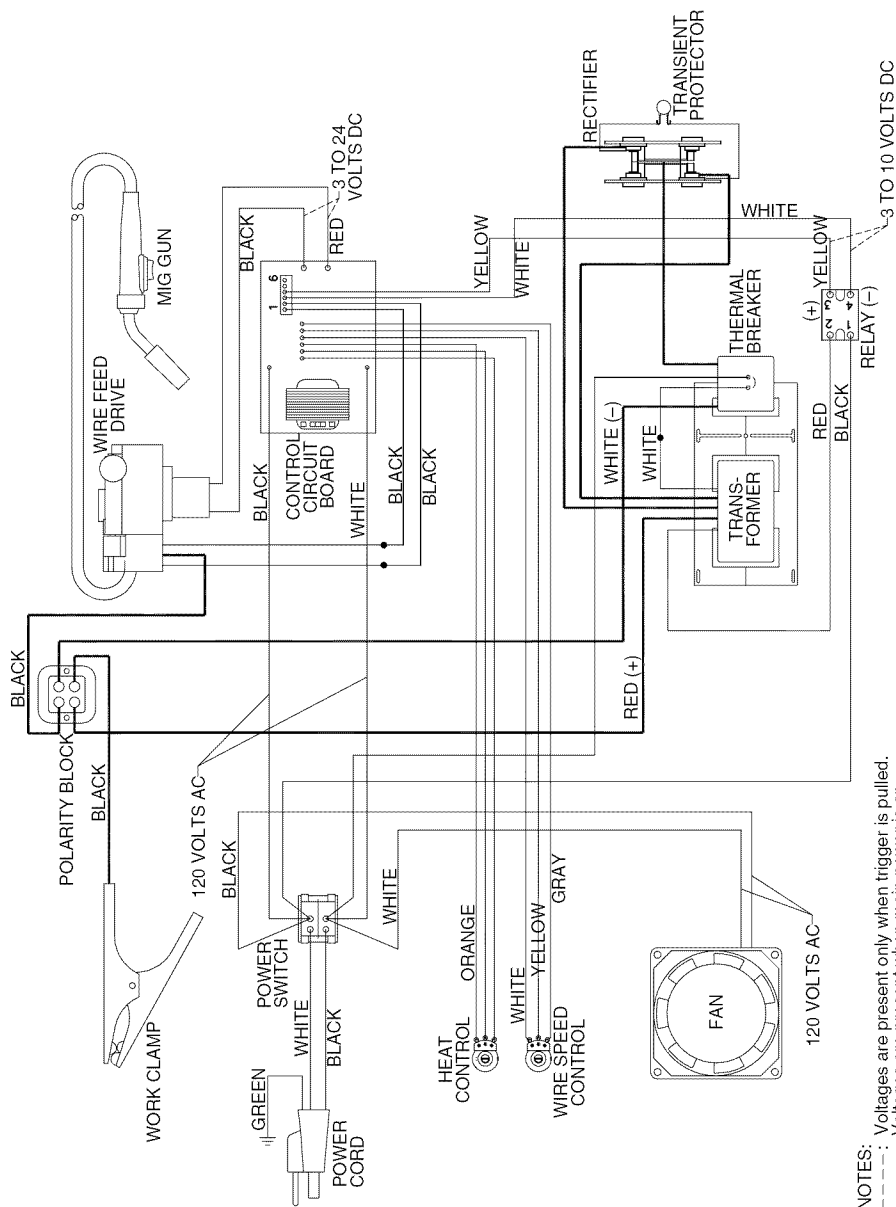

NOTES:
 - Voltages are present only when trigger is pulled.
 - Voltages are present when main power is on.

MODEL 205592

REPLACEMENT PARTS LIST

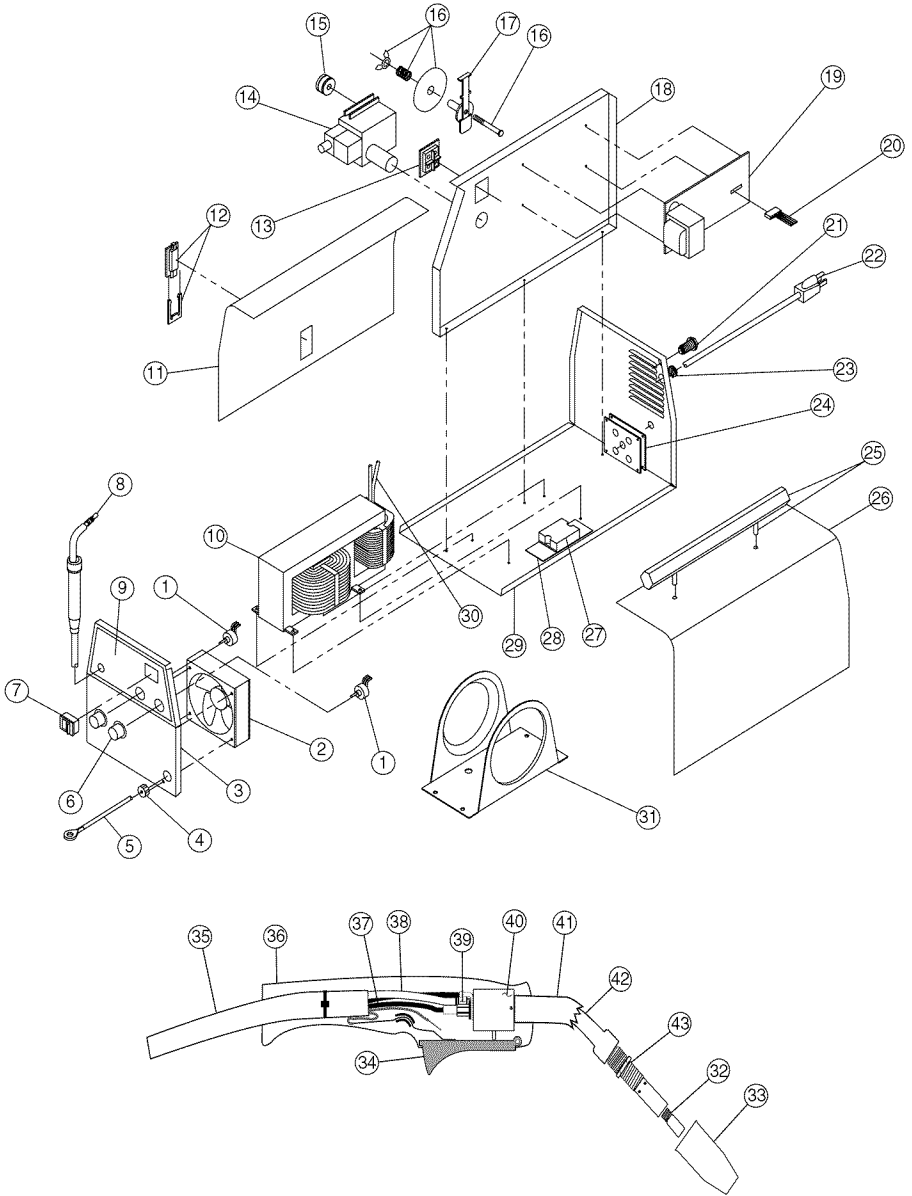

MODEL 205592

ITEM	DESCRIPTION	PART NO.
¥	202082 Sears 105 amp MIG Welder	117-084-902
1	Potentiometer	246-120-000
2	Fan	216-100-000
3	Front Panel	410-900-010
4	Strain Relief	541-057-000
5	Cable Assembly	238-223-666
6	Knob	246-107-666
7	Switch	246-423-000
8	10' MIG gun	238-593-000
9	Control Panel	410-869-011
10	Transformer	880-455-888
11	Left Side Panel	410-865-020
12	Slide Latch W/Clip	312-295-666
13	Terminal Block	246-414-000
14	Wire Feed Motor	880-406-000
15	Steel Drive Roller	310-187-666
16	Tension Hardware	131-419-000
17	Spindle	312-076-666
18	Center Panel	410-960-010
19	Circuit Board	880-456-666
20	Wire Harness	880-425-000
21	Fitting	253-333-000
22	Power Cord	248-351-000
23	Strain Relief	239-074-000
24	Rectifier	880-454-666
25	Handle W/Hardware	312-296-666
26	Right Side Panel	410-864-020
27	Relay	216-055-666
28	Heatsink	412-723-000
29	Base	880-431-000
30	Thermo Breaker	880-435-000
31	Tank Bracket	412-635-010
¥	Trafimet MIG Gun (10 foot cable)	238-593-000
32	Contact Tip 0.024" (0,6 mm)	43090
	Contact Tip 0.030" (0,8 mm)	43100
33	Nozzle	43480
34	Trigger (MIG Gun)	334-440-000
35	Gun Cable, Complete	334-465-000
36	Handle (With Trigger)	334-495-666
37	Gas Hose	059-217-040
38	Liner	334-468-666
39	Gas Hose Quick Connector	334-467-000
¥	Gun Head: Gas Valve, Conductor Tube, Conductor Tube Insulation, Gas Diffuser	334-490-666
40	Gas Valve	334-491-666
41	Conductor Tube Insulation	334-493-666
42	Conductor Tube	334-492-666
43	Gas Diffuser (MIG Gun)	334-494-666
†	Regulator	334-460-000
†	Tube Fitting for Regulator	253-406-666
†	Wire Spool Adapter (for 8")	312-110-666
†	Ground Clamp	239-010-102
†	Welding Face Shield	332-239-666
†	Not Shown In Drawing	
¥	Complete Assembly	

SCHEMATIC

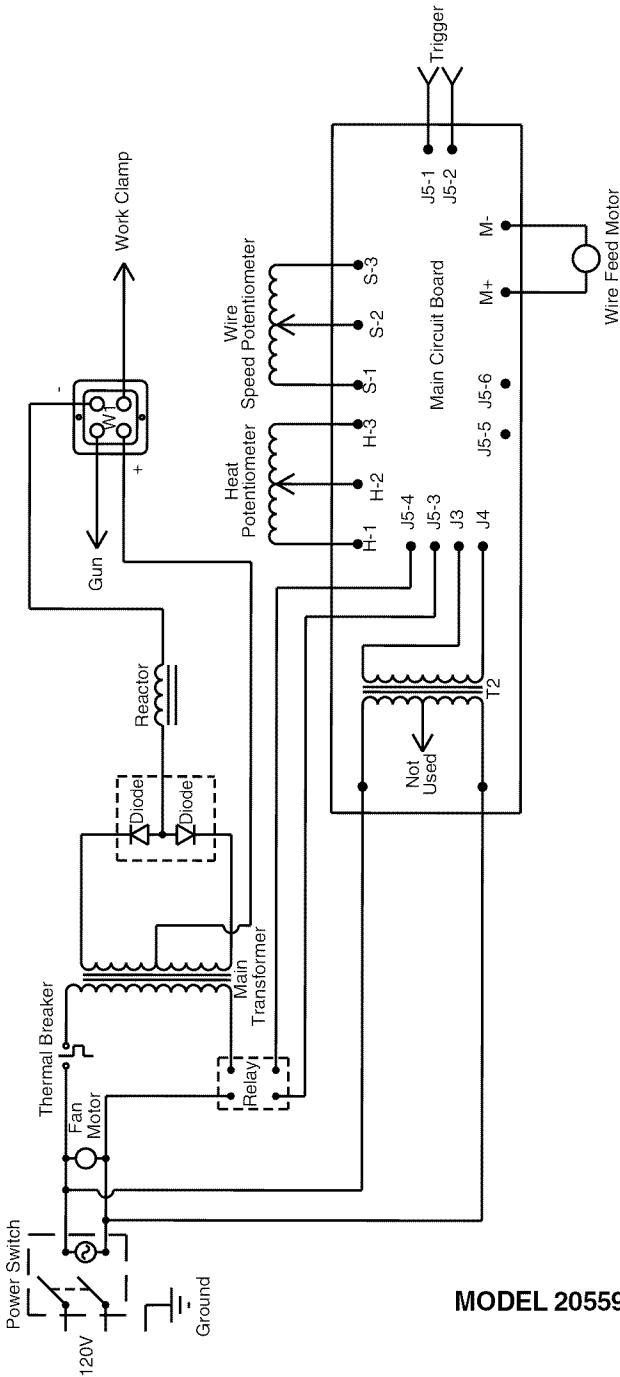

MODEL 205592

**For the repair or replacement parts you need
delivered directly to your home**
Call 7 am - 7 pm, 7 days a week
1-800-366-PART
(1-800-366-7278)

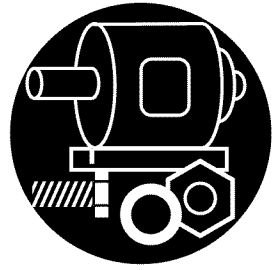

For in-home major brand repair service
Call 24 hours a day, 7 days a week
1-800-4-REPAIR
(1-800-473-7247)



The model number of your product is located on the welder nameplate.
If the parts you need are not stocked locally, your order will be electronically transmitted to a Sears Repair Parts Distribution Center for expedited handling.
When requesting service or ordering parts, always give the following information:

- Product Name
- Model Number
- Part Number
- Part Description

SEARS
REPAIR SERVICES
America's Repair Specialists

SEARS

CRAFTSMAN®

Operator's Guide

WIRE FEED MIG WELDER

Model No.
934.205592

- WARRANTY
- INTRODUCTION
- SAFETY SUMMARY
- SPECIFICATIONS
- INSTALLATION
- OPERATION
- MAINTENANCE
- SCHEMATIC
- WIRING DIAGRAM
- REPLACEMENT PARTS

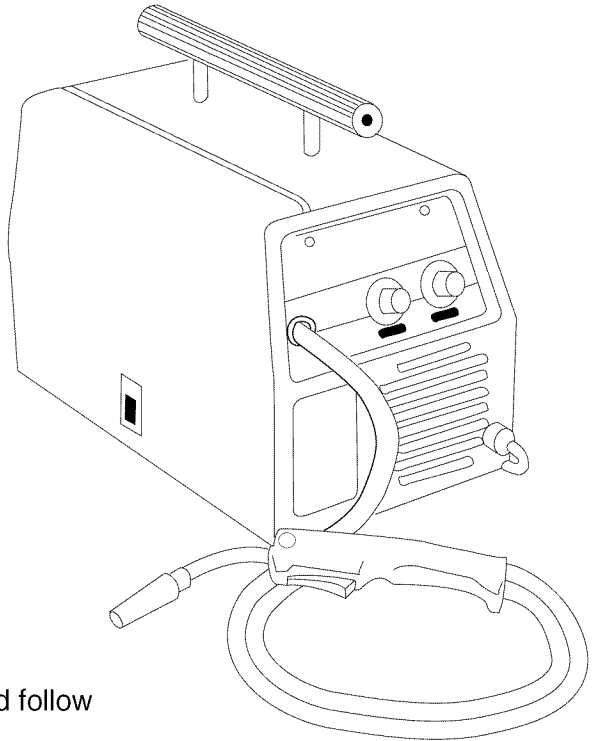

CAUTION: Read and follow all Safety Rules and Operating Instructions before First Use of this Product.

Sears, Roebuck and Co., Hoffman Estates, IL 60179 USA

CRAFTSMAN FULL WARRANTY

On Welding Gun or Cables, Welder, and Welder's Transformer

Full One Year Warranty for Craftsman Welding Gun or Cables. For one year from the date of purchase, when the welding gun or cables are operated and maintained according to the owner's manual instructions, if the welding gun or cables fail due to a defect in material or workmanship, Sears will repair or replace the welding gun or cables free of charge. This warranty does not cover parts consumed in normal operation, such as contact tips, nozzles, gun liners, and drive rollers.

Full Three Year Warranty on Craftsman Welder For three years from the date of purchase, when the welder is operated and maintained according to the owner's manual instructions, if the welder fails due to a defect in material or workmanship, Sears will repair or replace the welder free of charge. This warranty does not cover the welding gun, cables, or normal consumable parts.

WARRANTY SERVICE IS AVAILABLE BY SIMPLY CONTACTING THE NEAREST SEARS SERVICE CENTER.

This warranty applies only while this product is in use in the United States.

This warranty gives you specific legal rights, and you may also have other rights which vary from state to state.

Sears Roebuck and Co., Dept. 817WA,
Hoffman Estates, IL 60179.

TABLE OF CONTENTS

CRAFTSMAN FULL WARRANTY	2
TABLE OF CONTENTS	3
INTRODUCTION	4
SAFETY SUMMARY	5
SAFETY INFORMATION	5
SHOCK HAZARDS	6
FIRE HAZARDS	6
FLASH HAZARDS	6
FUME HAZARDS	6
COMPRESSED GASSES AND EQUIPMENT HAZARDS	6
BURN HAZARDS	7
ADDITIONAL SAFETY INFORMATION	7
WELDER SPECIFICATIONS	8
DESCRIPTION	8
WELDER OPERATING CHARACTERISTICS	8
DUTY CYCLE	8
INTERNAL THERMAL PROTECTION	8
WELDER INSTALLATION	9
POWER SOURCE CONNECTION	9
POWER REQUIREMENTS	9
CONNECT TO POWER SOURCE	9
EXTENSION CORDS	9
ASSEMBLING THE WELDER	9
UNPACKING THE WELDER	9
INSTALL THE GROUND CLAMP	9
INSTALL THE TANK TRAY AND BRACKET	9
INSTALL THE SHIELDING GAS	10
CHECK THE GAS FLOW	11
ALIGN AND SET THE DRIVE ROLLER	11
STANDARD DRIVE ROLLER	11
INSTALL THE WELDING WIRE	12
SET THE WIRE DRIVE TENSION	14
PREPARATION	15
CHANGE POLARITY	15
OPERATION	16
CONTROLS AND INDICATORS	16
MAINTENANCE	17
GENERAL	17
REPLACE A GUN LINER	17
MAINTAINING THE CONTACT TIP	20
MAINTAINING THE NOZZLE	20
TESTING FOR A SHORTED NOZZLE	21
PREVENTIVE MAINTENANCE	21
TROUBLESHOOTING	21
WIRING DIAGRAM	23
REPLACEMENT PARTS LIST	24
SCHEMATIC	26

INTRODUCTION

This Welder User's Guide provides specific information about your wire feed welder. It is to be used together with the Welding Instruction Guide to provide all of the information needed to safely and effectively use your wire feed welder. The information in this book applies to your specific model of wire feed welder and gives instruction on set-up, installation, and actual use of the welder.

Where information is shown that does not necessarily apply to all models or brands of welder, it will be marked as either optional on some welder models or *does not apply to all models*.

Optional on some welder models

SAFETY SUMMARY

Every craftsman respects the tools with which they work. They know that the tools represent years of constantly improved designs and developments. The true craftsman also knows that tools are dangerous if misused or abused.

Reading this Operator's Guide and the Welding Instruction Guide before using the welder will enable you to do a better, safer job. Learn the welder's applications and limitations as well as the specific potential hazards peculiar to welding.

SAFETY INFORMATION

The following safety information is provided as guidelines to help you operate your new welder under the safest possible conditions. Any equipment that uses electrical power can be potentially dangerous to use when safety or safe handling instructions are not known or not followed. The following safety information is provided to give you the information necessary for safe use and operation.

When a procedure step is preceded by a **WARNING**, it is an indication that the step contains a procedure that might be injurious to a person if proper safety precautions are not heeded.

When a procedure step is preceded by a **CAUTION**, it is an indication that the step contains a procedure that might damage the equipment being used.

A **NOTE** may be used before or after a procedure step to highlight or explain something in that step.

READ ALL SAFETY INSTRUCTIONS CAREFULLY before attempting to install, operate, or service this welder. Failure to comply with these instructions could result in personal injury and/or property damage.

RETAIN THESE INSTRUCTIONS FOR FUTURE REFERENCE.

Note: The following safety alert

symbols identify important safety messages in this manual.

When you see one of the symbols shown here, be alert to the possibility of personal injury and carefully read the message that follows.



This symbol indicates that the possibility of electric shock hazard exists during the operation of the step(s) that follow.



This symbol indicates that the possibility of fire hazard exists during the operation of the step(s) that follow.

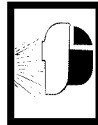

This symbol indicates that the helmet must be worn during the step(s) that follow to protect against eye damage and burns due to flash hazard.



This symbol indicates that the possibility of toxic gas hazard exists during operation of the step(s) that follow.



This symbol indicates that the possibility of being burned by hot slag exists during operation of the step(s) that follow.



This symbol indicates that the eye protection should be worn to protect against flying debris in the following step(s).



This symbol indicates that the possibility of injury or death exists due to improper handling and maintenance of compressed gas cylinders or regulators.

Full explanations of the specific hazards are shown in the WELDING INSTRUCTION GUIDE. Make sure you have read and understand all of the

information before proceeding with any of the instructions contained in this user's guide.

Published standards on safety are available. They are listed in **ADDITIONAL SAFETY INFORMATION** at the end of this **SAFETY SUMMARY**.

The National Electrical Code, Occupational Safety and Health Act regulations, local industrial codes and local inspection requirements also provide a basis for equipment installation, use, and service.

SHOCK HAZARDS



WARNING

ELECTRIC SHOCK CAN KILL! To reduce the risk of death or serious injury from shock, read, understand, and follow the following safety instructions. In addition, make certain that anyone else who uses this welding equipment, or who is a bystander in the welding area understands and follows these safety instructions as well.

FIRE HAZARDS



WARNING

FIRE OR EXPLOSION CAN CAUSE DEATH, INJURY, AND PROPERTY DAMAGE! To reduce risk of death, injury, or property damage from fire or explosion, read, understand, and follow the following safety instructions. In addition, make certain that anyone else that uses this welding equipment, or is a bystander in the welding area, understands and follows these safety instructions as well. **REMEMBER!** Welding by nature produces sparks, hot spatter, molten metal drops, hot slag, and hot metal parts that can start fires, burn skin, and damage eyes.

FLASH HAZARDS

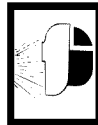

WARNING

ARC RAYS CAN INJURE EYES AND BURN SKIN! To reduce risk of injury from arc rays, read, understand, and follow the following safety instructions. In addition, make certain that anyone else that uses this welding equipment, or is a bystander in the welding area, understands and follows these safety instructions as well.

FUME HAZARDS



WARNING

FUMES, GASSES, AND VAPORS CAN CAUSE DISCOMFORT, ILLNESS, AND DEATH! To reduce risk of discomfort, illness, or death, read, understand, and follow the following safety instructions. In addition, make certain that anyone else that uses this welding equipment or is a bystander in the welding area, understands and follows these safety instructions as well.

COMPRESSED GASSES AND EQUIPMENT HAZARDS



WARNING

IMPROPER HANDLING AND MAINTENANCE OF COMPRESSED GAS CYLINDERS AND REGULATORS CAN RESULT IN SERIOUS INJURY OR DEATH! To reduce risk of injury or death from compressed gasses and equipment hazards, read understand and follow the following safety instructions. In addition, make certain that anyone else who uses this welding

equipment or a bystander in the welding area understands and follows these safety instructions as well.

Do not use flammable gasses with MIG welders. Only inert or nonflammable gasses are suitable for MIG welding. Examples are Carbon Dioxide, Argon, Helium, etc. or mixtures of more than one of these gasses.

BURN HAZARDS



WARNING

Hot slag can cause fires and serious injury from burns. To reduce the risk of discomfort or serious injury due to burns always wear heavy protective clothing, eye and face protection, and gloves designed for welding. To prevent the risk of fires starting, use a metal plate or some other material with a high flash point to catch and shield combustibles from the hot slag.

ADDITIONAL SAFETY INFORMATION

For additional information concerning welding safety, refer to the following standards and comply with them as applicable.

- ANSI Standard Z87.1 — SAFE PRACTICE FOR OCCUPATION AND EDUCATIONAL EYE AND FACE PROTECTION — obtainable from the American National Standards Institute, 11 West 42nd St., New York, NY 10036 Telephone (212) 642-4900, Fax (212) 398-0023 — www.ansi.org
- NFPA Standard 51B — CUTTING AND WELDING PROCESS — obtainable from the National Fire Protection Association, 1 Batterymarch Park, P.O. Box 9101, Quincy, MA 02269-9101 Telephone (617) 770-3000, Fax (617) 770-0700 — www.nfpa.org
- CGA Pamphlet P-I — SAFE HANDLING OF COMPRESSED GASSES IN CYLINDERS — obtainable from the Compressed Gas Association, 1725 Jefferson Davis Highway, Suite 1004, Arlington, VA 22202-4102 Telephone (703) 412-0900 Fax (703) 412-0128 — www.cagnet.com
- OSHA Standard 29 CFR, Part 1910, Subpart Q., WELDING, CUTTING AND BRAZING — obtainable from your state OSHA office or U. S. Dept. of Labor OSHA, Office of Public Affairs, Room N3647, 200 Constitution Ave. Washington, DC 20210 — www.osha.gov
- CSA Standard W117.2 — Code for SAFETY IN WELDING AND CUTTING. — obtainable from Canadian Standards Association, 178 Rexdale Blvd. Etobicoke, Ontario M9W 1R3 — www.csa.ca
- American Welding Society Standard A6.0. WELDING AND CUTTING CONTAINERS WHICH HAVE HELD COMBUSTIBLES. — obtainable from the American Welding Society, 550 NW Le Jeune Road, Miami, FL 33126 Telephone (800) 443-9353, Fax (305) 443-7559 — www.amweld.org or www.aws.org

WELDER SPECIFICATIONS

DESCRIPTION

Your new wire feed welder is designed for maintenance and sheet metal fabrication. The welder consists of a single-phase power transformer, stabilizer, rectifier, and a unique built-in control/feeder. This MIG welder is capable of welding with 0.024 (0.6mm) and 0.030 (0.8mm), solid steel wire on dc reverse polarity and with .030 inch self-shielding flux-core wire on dc straight polarity. Larger, 0.035 inch (0.9mm) diameter solid steel wire, on dc reverse polarity, and self shielding flux-core wire on dc straight polarity may also be used on this welder. The use of larger diameter wire makes welding difficult and the results cannot be guaranteed. The manufacturer does not recommend the use of larger diameter wire.

Now you can weld sheet metal from 24 gauge up to 1/4 inch thick with a single pass. You can weld thicker steel with beveling and multiple pass techniques. Table 1 lists your MIG welder specifications.

Table 1. Welder Specifications

Primary (input) volts	120 Vac
Primary (inputs) Amps	25
Phase	Single
Frequency	60 Hz
Secondary (output) volts	19.5
Secondary (UL output) amps	105
Open Circuit Volts (Max.)	28 Vdc
Duty Cycle Rating	20%

WELDER OPERATING CHARACTERISTICS

DUTY CYCLE

The duty cycle rating of a welder defines how long the operator can weld and how long the welder must be rested and cooled. Duty cycle is expressed as a percentage of 10 minutes and represents the maximum welding time

allowed. The balance of the 10-minute cycle is required for cooling.

Your new welder has a duty cycle rating of 20% at the rated output. This means that you can weld for two (2) minutes out of 10 with the remaining eight (8) minutes required for cooling. (See Table 2).

Table 2. Duty Cycle Ratings

Duty Cycle Rating	Maximum Welding Time	Required Resting Time
20%	2 minutes	8 minutes
40%	4 minutes	6 minutes
60%	6 minutes	4 minutes
80%	8 minutes	2 minutes
100%	10 minutes	0 minutes

INTERNAL THERMAL PROTECTION

CAUTION

Do not constantly exceed the duty cycle or damage to this welder can result. If you exceed the duty cycle of your welder, an internal thermal protector will open, shutting off all welder functions except the cooling fan. If this happens, **DO NOT SHUT OFF THE WELDER.** Leave the welder turned on with the fan running. After cooling, the thermal protector will automatically reset and the welder will function normally again. However, you should wait at least 10 minutes after the thermal protector opens before resuming welding. You must do this even if the thermal protector resets itself before the 10 minutes is up or you may experience less than specified duty cycle performance.

If you find that your welder will not weld for 2 minutes without stopping, reduce the wire speed slightly and tune the welder in at the lowest wire speed setting that still produces a smooth arc. Welding with the wire speed set too high causes excessive current draw and shortens the duty cycle.

WELDER INSTALLATION

POWER SOURCE CONNECTION

POWER REQUIREMENTS

This welder is designed to operate on a properly grounded 120 Volt, 60 Hz, single-phase alternating current (ac) power source fused with a 20 amp time-delayed fuse or circuit breaker. It is recommended that a qualified electrician verify the **ACTUAL VOLTAGE** at the receptacle into which the welder will be plugged and confirm that the receptacle is properly fused and grounded. The use of the proper circuit size can eliminate nuisance circuit breaker tripping when welding.

DO NOT OPERATE THIS WELDER if the ACTUAL power source voltage is less than 105 Volts ac or greater than 132 Volts ac. Contact a qualified electrician if this problem exists. Improper performance and/or damage to the welder will result if operated on inadequate or excessive power.

CONNECT TO POWER SOURCE



WARNING

High voltage danger from power source! Consult a qualified electrician for proper installation of receptacle at the power source.

This welder must be grounded while in use to protect the operator from electrical shock. If you are not sure if your outlet is properly grounded, have it checked by a qualified electrician. Do not cut off the grounding prong or alter the plug in any way and do not use any adapters between the welder's power cord and the power source receptacle.

Make sure the POWER switch is OFF then connect your welder's power cord to a properly grounded 120 Vac, 60 Hz, single phase, 20 amp power source.

EXTENSION CORDS

For optimum welder performance, an extension cord should not be used unless absolutely necessary. If necessary, care must be taken in selecting an extension cord appropriate for use with your specific welder.

Select a properly grounded extension cord that will mate directly with the ac power source receptacle and the welder power cord without the use of adapters. Make certain that the extension is properly wired and in good electrical condition.

Extension cords must be at the smallest a #12 gauge cord. Do not use an extension cord over 25 ft. in length.

ASSEMBLING THE WELDER

The following procedures describe the process required to assemble, install, maintain, and prepare to weld with your new wire feed welder.

UNPACKING THE WELDER

1. Remove any cartons or bags containing parts/accessories.
2. Open the cartons or bags packed with your welder and inspect their contents for damage. Report any missing or damaged items immediately.
3. Grasp the top handle of the welder and lift the welder out of the carton.

INSTALL THE GROUND CLAMP

Connect the ground clamp to the ground cable (coming out the front of the welder) according to the instructions packaged with the ground clamp.

INSTALL THE TANK TRAY AND BRACKET

The tank tray bracket is installed on the back of the welder, see Figure 1.

IMPORTANT – GAS CYLINDER SIZE RESTRICTION! The tank tray you have just installed on the back of the welder will handle gas cylinders no larger than 20 cubic feet. If you select a cylinder larger than 20 cubic feet, it must be chained to a wall or other fixed support.

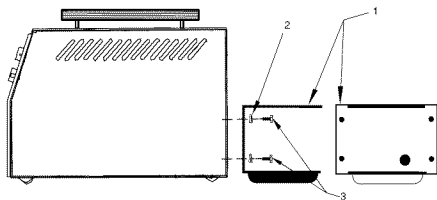

Figure 1. Mount Tank Tray Bracket To Welder

1. Align the four tank tray bracket (1) mounting holes (as shown in Figure 1) with the four staked nuts on the rear of the welder.
2. Start one ¼ inch split lock washer (2) and a ¼-20 x ½ inch hex bolt (3) in one of the top tank tray bracket (1) mounting holes, then start each of the other three split lock nuts (2) and ¼-20 x ½ inch hex bolts (3) through the remaining mounting holes.
3. Tighten all four hex bolts.

INSTALL THE SHIELDING GAS



WARNING

IMPROPER HANDLING AND MAINTENANCE OF COMPRESSED GAS CYLINDERS AND REGULATORS CAN RESULT IN SERIOUS INJURY OR DEATH! Always secure gas cylinders to the tank bracket kit, a wall, or other fixed support to prevent the cylinder from falling over and rupturing. Read, understand, and follow all the COMPRESSED GASSES AND EQUIPMENT HAZARDS in the SAFETY SUMMARY at the front of this manual.

Secure your gas cylinder to the tank bracket kit, a wall, or other fixed support.

1. Remove the protective cap from the cylinder and inspect the regulator connecting threads for dust, dirt oil, and grease. Remove any dust or dirt with a clean cloth. **DO NOT ATTACH THE REGULATOR IF OIL, GREASE, OR DAMAGE ARE PRESENT.**
2. Open the cylinder valve FOR JUST AN INSTANT to blow out any foreign matter inside the valve port to reduce the risk of plugging or damaging the regulator. Never aim the open cylinder valve port at yourself or bystanders.
3. Screw the regulator supplied with this welder (see Figure 2) into the cylinder valve and tighten with a wrench.

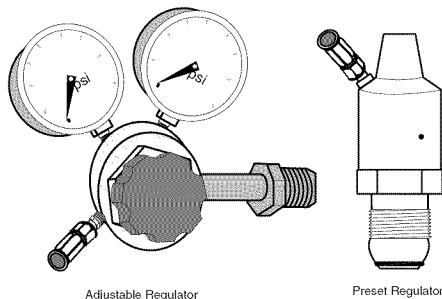

Figure 2. Gas Regulators

4. Insert the gas hose into the outlet port of the gas regulator. The hose locks in place in the fitting when pressed into the port.
5. To remove the gas hose, press down on the ring at the rear of the gas fitting, and pull the hose out of the fitting.

CHECK THE GAS FLOW



WARNING

IMPROPER HANDLING AND MAINTENANCE OF COMPRESSED GAS CYLINDERS AND REGULATORS CAN RESULT IN SERIOUS INJURY OR DEATH!

To reduce the risk of injury or death, always stand to the side of the cylinder opposite the regulator when opening the cylinder valve, keeping the cylinder valve between you and the regulator. Never aim the open cylinder valve port at yourself or bystanders. Failure to comply with this warning could result in serious personal injury.

Note: If the cylinder you have is equipped with male regulator connecting threads instead of female, you will need to obtain a special compressed gas cylinder adapter from your gas supplier to install between your gas cylinder and regulator.

- The gas control function does not require the welder to be turned on or plugged in.
1. Slowly crack open the cylinder valve, then turn open **ALL THE WAY**.
 2. Pull the trigger on the gun to allow the gas to flow. **KEEP THE TRIGGER PULLED**. Listen and feel for gas flowing from the end of the welding gun. If your regulator has no adjustment, it has been pre-set at the factory for a flow of 20 cubic feet per hour. If your gas regulator has an adjustment to control the gas flow rate, turn the adjustment key clockwise to increase gas flow; counterclockwise to reduce flow. For most welding, the gas flow should be set at 15-20 cubic feet per hour. If no gas is heard or felt, verify all steps involved in connecting the gas.

3. Release the trigger.

Note: If welding outside or in a draft, it may become necessary to set up a windbreak to keep the shielding gas from being blown from the weld area.

- **MAKE SURE TO TURN OFF THE GAS CYLINDER VALVE WHEN DONE WELDING.**

ALIGN AND SET THE DRIVE ROLLER

Before installing any welding wire into the unit, the proper sized groove must be placed into position on the wire drive mechanism. Change to a neoprene drive roller when welding with aluminum wire.

STANDARD DRIVE ROLLER

Change the standard drive roller according to the following steps:

1. Remove the drive tension by unscrewing the tension adjusting screw (**ALL THE WAY** in a counter-clockwise direction). The drive tension screw will come loose, allowing you to pull the drive tension arm up away from the drive roller. Make sure to keep the screw and the spring in place with the drive tension arm.
2. If there is wire already installed in the welder, roll it back onto the wire spool by hand-turning the spool counter-clockwise. Be careful not to allow the wire to come out of the rear end of the gun without holding onto it or it will unspool itself. Put the end of the wire into the hole on the outside edge of the wire spool and bend it over to hold the wire in place. Remove the spool of wire from the welder.
3. Loosen the drive roller setscrew and pull the drive roller off the drive shaft.

Note: The drive roller has two wire size grooves built into it. When installing the drive roller the number stamped on the drive roller for the wire size you are using should be facing away from you. If you can read the wire size you are using on the drive roller, it is installed backwards. Use only the proper size drive roller when using your welder.

4. Find the side of the drive roller that is stamped with the same wire diameter as that of the wire being installed (see Figure 3, and if in metric, see DESCRIPTION in the WELDER SPECIFICATIONS section). Make certain the spacing washer is still on the motor shaft and push the drive roller onto the motor shaft, aligning the setscrew with the flat side of the drive shaft. Make sure the side stamped with the desired wire diameter is away from you.

Drive Roller

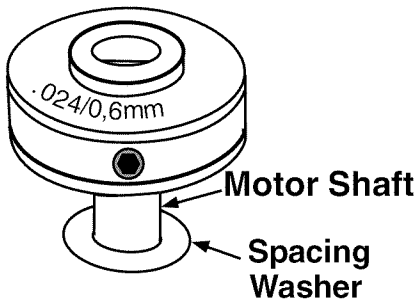

Figure 3. Drive Roller

5. Slide the roller onto the shaft so that the groove in the roller lines up with the inlet tube and the welding gun liner. You can look at the alignment from the top of the welder.

6. Tighten the setscrew, while holding the drive roller in place.

INSTALL THE WELDING WIRE



WARNING

Electric shock can kill! Always turn the POWER switch OFF and unplug the power cord from the ac power source before installing wire.

Be very careful when removing the welding nozzle. The contact tip on this welder is electrically hot as long as POWER is turned ON. Make certain POWER is turned OFF.

1. Remove the nozzle and contact tip from the end of the gun assembly.
2. Make sure the proper groove on the drive roller is in place for the wire being installed. If the proper groove is not in place, change the drive roller as described above.
3. Unwrap the spool of wire then find the leading end of the wire (it goes through a hole in the outer edge of the spool and is bent over the spool edge to prevent the wire from unspooling) BUT DO NOT UNHOOK IT YET.
4. Place the spool on the spindle in such a manner that when the wire comes off the spool, it will look like the top illustration in Figure 4. The welding wire should always come off the top of the spool into the drive mechanism.

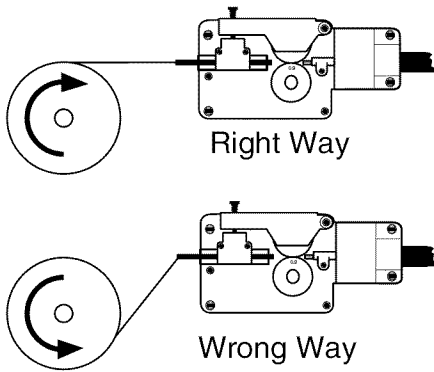

Figure 4. Right and Wrong Way To Feed Wire From Spool

5. If you are installing a four-inch spool of wire, install the drive brake hardware on the top of the spool of wire according to Figure 5A. If you are installing an eight-inch spool, install the spindle adapter and drive brake hardware as shown in Figure 5B. The purpose of the drive brake is to cause the spool of wire to stop turning at nearly the same moment that wire feeding stops.
6. Once the drive brake hardware is installed, set the spool tension. With one hand, turn the wire spool and continue turning it while adjusting the tension on the spool. With your free hand, tighten (turn clockwise) the wing nut that holds the spool in place. Stop tightening when drag is felt on the wire spool that you are turning, then stop hand turning the wire spool.

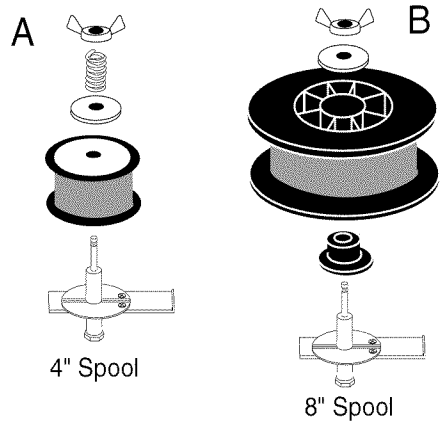

Figure 5. Drive Brake Assemblies with Four Inch and Eight Inch Wire Spools

- Note:** If TOO MUCH tension is applied to the wire spool, the wire will slip on the drive roller or will not be able to feed at all. If TOO LITTLE tension is applied, the spool of wire will want to unspool itself. Readjust the drive brake tension as necessary to correct for either problem.
7. After checking to make sure that your welder is disconnected from the ac power source, free the leading end of the wire from the spool, but do not let go of it until told to do so, or the wire will unspool itself.
 8. Using a wire cutter, cut the bent end off the leading end of the wire so that only a straight leading end remains.
 9. Loosen the tension adjusting screw holding the drive tension arm in place and lift the tension arm up off the drive roller.
 10. Insert the leading end of the wire into the inlet guide tube. Then push it across the drive roller and into the gun assembly about six inches.

CAUTION

Make certain that the welding wire is actually going into the gun liner. Be very sure it has not somehow been accidentally been routed alongside the liner or even in some other direction. If this should happen, the wire could feed inside the cable casing or take a right angle and follow the wires and gas hose inside the welder. It could also feed back on itself jamming up the mechanism.

11. Line the wire up in the inside groove of the drive roller, then allow the drive tension arm to drop onto the drive roller.
12. Tighten (turn clockwise) the drive tension adjusting screw until the tension roller is applying enough force on the wire to prevent it from slipping out of the drive assembly.
13. Let go of the wire.
14. Connect the welder power cord to the ac power source. Turn the welder POWER switch ON. Set the VOLTAGE switch to the voltage (heat) setting recommended for the gauge metal that is to be welded. Refer to the label mounted on the cover, inside the drive compartment, for recommended voltage (heat) settings for your welding job. The VOLTAGE selector controls the weld heat. There are eight voltage (heat) selections (numbered 1 through 8) available on this welder. Numbered position 1 provides the lowest voltage (heat) and position 8 the highest voltage (heat).
15. Set the WIRE SPEED control to the middle of the wire speed range.
16. Pull the trigger on the welding gun to feed the wire through the gun assembly.
17. When at least an inch of wire sticks out past the end of the gun, release the trigger.

18. Select a contact tip stamped with the same diameter as the wire being used. If stamped in metric, see DESCRIPTION.
19. Slide the contact tip over the wire (protruding from the end of the gun). Thread the contact tip into the end of the gun and hand-tighten securely.
20. Install the nozzle on the gun assembly. For best results, coat the inside of the nozzle with anti-stick spray or gel (part #4312, not supplied).
21. Cut off the excess wire that extends past the end of the nozzle.

SET THE WIRE DRIVE TENSION



WARNING

To reduce the risk of arc flash, make certain that the wire coming out of the end of the gun does not come in contact with the workpiece clamp or any grounded material during the drive tension setting process or arcing will occur.

1. Pull the trigger on the gun.
2. Turn the drive tension adjustment knob clockwise, increasing the drive tension until the wire seems to feed smoothly without slipping.
3. Block the end of the nozzle by holding it up against something that doesn't conduct electricity, such as a block of wood or a concrete floor, then trigger the gun again. The wire should slip at the drive roller. However, if the wire bird-nests at the drive roller, rethread the drive system using less drive tension and try again.

- When the drive tension is set correctly, there should be no slippage between the wire and the drive roller. However, if an obstruction occurs along the wire feed path, the wire should then slip on the drive roller.

PREPARATION

CHANGE POLARITY

This welder allows you the capability to change the welding current polarity. You may select either dc Straight (dc – Flux Cored) or dc Reverse Polarity (dc + MIG). For welding steel with solid wire, stainless steel, flux cored hardfacing of steel, and silicon bronze welding of steel, select dc Reverse Polarity (dc + MIG). When using self-shielding, flux-core steel wire, use dc Straight Polarity (dc – Flux Cored).

Change the polarity of your welder according to the following procedure steps. Figure 8 shows what the polarity block should look like for each polarity setting.



WARNING

Electric shock can kill! Always turn the POWER switch OFF and unplug the power cord from the ac power source before changing polarity.

CAUTION

Do not use a ratchet, crescent or other lever type wrench to tighten the nuts on the polarity bus. The nuts must be hand tightened with a 7/16 inch nut driver only. Too much torque applied to the one of the nuts could cause the threaded post to break off.

Tools Required:

- 7/16 inch nut driver
- With a 7/16 inch nut driver, remove all four nuts and pull out the vertically mounted copper straps.
 - Replace the copper straps horizontally in the dc Straight Polarity (dc – Flux Cored) configuration shown in Figure 6.

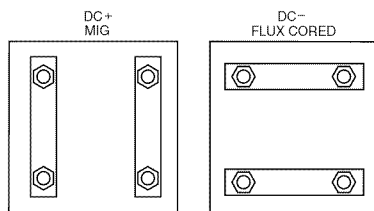

Figure 6. Welder Polarity Selections

- Start the four nuts on the four connecting posts and hand snug each nut with the 7/16 nut driver. Do not use a ratchet, crescent or other lever type wrench.

OPERATION

Operation of this welder consists of selecting and adjusting operating controls for optimum voltage (welding heat) and wire speed settings.

CONTROLS AND INDICATORS



WARNING

Electric shock can kill! To remove the risk of electric shock, be aware that the VOLTAGE selector, when OFF, does not remove power from all internal circuitry in the welder.

POWER – This welder has a POWER switch mounted on the front panel. The POWER switch is used to initiate (turn the welder ON) or extinguish (turn the welder OFF) ac power to the welder.

VOLTAGE SELECTOR – The voltage selector controls the welding heat. The voltage selector provides continuous voltage (heat) adjustment but has reference number settings 1–8. Number 1 is the lowest voltage (heat) setting and number 8 the highest. Refer to the label under the welder hood for recommended voltage (heat) settings for your welding job.

WIRE SPEED CONTROL – The WIRE SPEED CONTROL adjusts the speed at which the wire is fed out of the welding gun. The wire speed needs to be closely matched (tuned-in) to the rate at which it is being melted off (see TUNING IN THE WIRE SPEED, (in the Welding Instruction Guide). Some things that affect wire speed selection are the type and diameter of the wire being used, the heat setting selected, and the welding position to be used.

MAINTENANCE

GENERAL

This welder has been engineered to give many years of trouble-free service providing that a few very simple steps are taken to properly maintain it.

1. Keep the wire drive compartment lid closed at all times unless the wire needs to be changed or the drive tension needs adjusting.
2. Keep all consumables (contact tips, nozzles, and gun liner) clean and replace when necessary. See **CONSUMABLE MAINTENANCE AND TROUBLESHOOTING** later in this section for detailed information.
3. Replace power cord, ground cable, ground clamp, or gun assembly when damaged or worn.
4. Periodically clean dust, dirt, grease, etc. from your welder. Every six months or as necessary, remove the side panels from the welder and air-blow any dust and dirt that may have accumulated inside the welder.



WARNING

ELECTRIC SHOCK CAN KILL! To reduce the risk of electric shock, always unplug the welder from its ac power source before removing side panels.

IT IS VERY IMPORTANT TO MAINTAIN THE CONSUMABLES TO AVOID THE NEED FOR PREMATURE REPLACEMENT OF THE GUN ASSEMBLY.

The **GUN LINER** is intended to provide an unrestricted path for the welding wire to flow through the gun assembly. Over time it will accumulate dust, dirt, and other debris. Replacement is necessary when these accumulations begin to restrict the free flow of wire through the gun assembly.

REPLACE A GUN LINER

When removing or installing a gun liner, care must be taken not to kink or otherwise damage the gun liner or replacement will be necessary. See Figure 7 for the drive assembly and Figure 8 for the gun assembly.

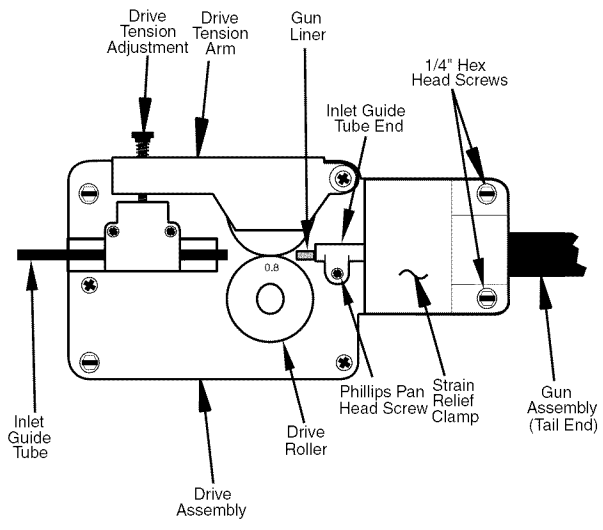

Figure 7. Drive Assembly

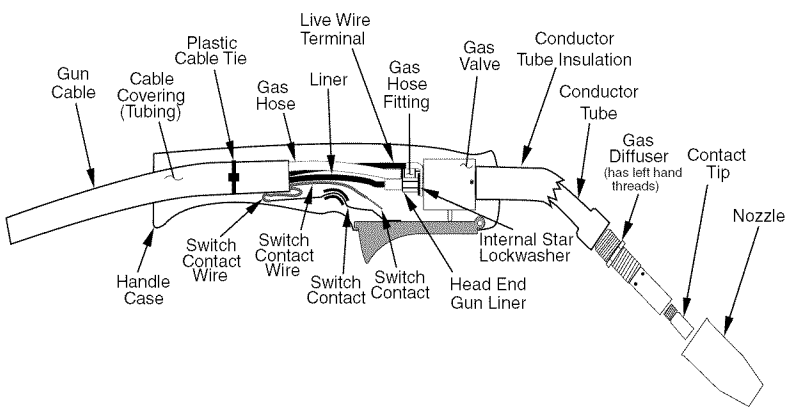

Figure 8. Gun Assembly

Tools Required:

- 5/16 inch open end wrench
 - Crescent Wrench (6 or 8 inch)
 - 9 mm open end wrench (or 3 inch crescent)
 - Phillips Screwdriver
 - Straight Blade Screwdriver or ¼ inch hex driver
1. Turn OFF welder POWER SWITCH.
 2. Open the welder side panel.
 3. Loosen the tension arm and lift it up off the drive roller.
 4. Turn the wire spool counter-clockwise (be sure to hold onto the wire itself while turning the spool or the wire will unspool itself when it becomes free of the gun liner), removing wire from gun assembly.
 5. Remove two ¼ inch hex head screws (may also be removed with a straight blade screwdriver) and one pan head Phillips screw (inlet guide tube end) from the drive roller and lift away the strain relief clamp that holds the tail end of the gun in the drive assembly.
 6. Leave the gun assembly (consists of nozzle, gas diffuser, conductor tube, handle and cable containing gas tubing electrical cable and liner) attached to the welder but move the welder to a place where the gun assembly can be laid out straight on a table or workbench or similar flat surface.
 7. Unscrew and remove the nozzle.
 8. With a crescent wrench (six or eight inch), turn the gas diffuser clockwise (has left hand threads) and remove the gas diffuser (and contact tip together) from the conductor tube on the end of the gun.
 9. Remove the four Phillips head screws that hold the handle case together. With the exception of the trigger, completely remove the contents of the handle case.

10. Cut the plastic cable tie away from the cable covering (tubing).

Note: In the following procedure step, it may be necessary to remove the gas fitting from the gas valve in order to make room to turn out the head end of the gun liner.

11. With a 5/16 inch open end wrench, unscrew the head end of the liner from the gas valve. Save the internal star lock-washer and note the orientation of the live wire terminal. If you find it necessary to remove the gas hose connector, press down on the ring at the rear of the gas fitting to release the gas hose and pull out the gas hose. Remove the gas fitting with a 9 mm open end wrench or three inch crescent.
12. Pull the liner out of the cable covering (tubing) from the handle end and push the small piece of liner out of the conductor tube.
13. Carefully insert the new liner into the cable taking particular care to keep the liner straight (especially at the terminal end) to ease its passage through cable covering. It may be desirable, perhaps even necessary, to apply some silicon grease to the outside of the new liner so that it will slide easily through the cable.
14. Insert the new piece of liner in the conductor tube.

Note: If you found it necessary to remove the gas and hose connector at step 9, remember to reconnect it after completing step 12. The gas hose can be reconnected by simply pushing it into the back of the connector.

15. Insert the head of the gun liner through the internal star lock washer and the live wire terminal (repeat the orientation noted in step 9). With a 5/16 inch open end wrench, screw the head end of the new liner into the gas valve.

16. Insert a new plastic cable tie in place around the cable and tighten it in approximately the same location as the plastic cable tie that was cut in step 8.
17. Return all components to the handle casing and realign them as they were originally.
18. With both halves of the handle case in place, tighten the four Phillips pan head screws making sure the trigger remains seated in place.
19. Push the cable into the welder far enough so that the end of the gun liner protrudes through the inlet guide tube end of the wire-feed torch clamp far enough so that it is within approximately 1/16 inch of touching the drive roller.
20. Make sure the cable covering (tubing) is far enough in the machine so that it is covered by the wire-feed torch clamp.
21. Tighten the two ¼ inch hex head screws (may also be tightened by a straight blade screwdriver) and one pan head Phillips screw to the drive roller securing the gun in place.
22. Re-install the welding wire according to **INSTALL THE WELDING WIRE**.

MAINTAINING THE CONTACT TIP

The purpose of the CONTACT TIP is to transfer welding current to the welding wire while allowing the wire to pass through it smoothly.

Always use a contact tip stamped with the same diameter as the wire it will be used with.

1. If the wire burns back into the tip, remove the tip from the gun and clean the hole running through it with an oxygen-acetylene torch tip cleaner or tip drill.

2. Over time, the hole in the contact tip will become worn by the wire passing through it. The more worn this hole becomes, the less efficient is the transfer of welding current to the wire and eventually arc breakage and difficult arc starting will result. Replace contact tips when signs of wear become apparent.

MAINTAINING THE NOZZLE

The nozzle directs the shielding gas to the weld puddle, determines the size of the shielding area, and prevents the electrically *hot* contact tip from contacting the work piece.

CAUTION

KEEP THE NOZZLE CLEAN! During the welding process, spatter and slag will build up inside the nozzle and must be cleaned out periodically. Failure to clean and/or replace the nozzle in a timely fashion **WILL CAUSE DAMAGE TO THE FRONT-END OF THE GUN ASSEMBLY**.

For best results, coat the inside of a new or freshly cleaned nozzle with anti-stick spray or gel.

1. Stop welding and clean any accumulated slag or spatter from the nozzle every 5 to 10 minutes of welding time.
2. When welding overhead, if any molten metal drips from the weld puddle and falls into the nozzle, **STOP WELDING IMMEDIATELY** and clean the nozzle.
3. If the slag cannot be thoroughly cleaned from the nozzle, **REPLACE THE NOZZLE!**

Failure to keep the nozzle adequately cleaned can result in the following problems:

A **SHORTED** nozzle results when spatter buildup bridges the insulation in the nozzle allowing welding current to flow through it as well as the contact tip. When shorted, a nozzle will steal welding current from the wire whenever it contacts the grounded work piece. This causes erratic welds and reduced penetration.

In addition, a shorted nozzle overheats the end of the gun, which can **DAMAGE** the front-end of the gun.

A **RESTRICTED** nozzle is created when enough slag builds up in the nozzle to affect the direction, concentration, and or rate of the shielding gas flow. This problem can cause porous, brittle welds and reduce penetration.

TESTING FOR A SHORTED NOZZLE

Arcing between the nozzle and the work piece **ALWAYS** means the nozzle is shorted, but this can be hard to detect through the lens of a welding helmet. The following testing method is another way to tell if a nozzle is shorted.

With the welder unplugged from the ac power source, touch the probes of an ohmmeter or continuity tester to the end of the contact tip and the outside of the nozzle. If there is any continuity at all, the nozzle **IS** shorted. Clean or replace as needed.

PREVENTIVE MAINTENANCE

Except for internal and external cleaning, cleaning the nozzle, and occasionally retightening screws, there is no periodic maintenance recommended for your welder.

TROUBLESHOOTING

The following **TROUBLESHOOTING** information is provided as a guide to help resolve some of the more common problems that could be encountered.

Table 3 is a troubleshooting table provided to help you determine a possible remedy when you are having a problem with your welder. This table does not provide all possible solutions, only those possibilities considered to likely be common faults. The table consists of a **TROUBLE** or symptom, a **POSSIBLE CAUSE** for that symptom, and a **POSSIBLE REMEDY** for that symptom.

Table 3. Troubleshooting

TROUBLE	POSSIBLE CAUSE	POSSIBLE REMEDY
Dirty, porous brittle weld	<ol style="list-style-type: none"> 1. Plugged welding nozzle 2. No shielding gas 3. Wrong Type of Gas 4. Dirty or rusty welding wire 	<ol style="list-style-type: none"> 1. Clean or replace nozzle 2. Tank empty, flow restricted, or regulator set too low 3. See SELECTING SHIELDING GAS in the WELDING INSTRUCTION GUIDE for proper selection 4. Replace spool of wire
Wire feed works but no arc	<ol style="list-style-type: none"> 1. Bad ground or loose connection 2. Bad connection to gun or faulty gun 	<ol style="list-style-type: none"> 1. Check ground and connections tighten as necessary 2. Check connection to gun or replace gun
Arc works but not feeding wire.	<ol style="list-style-type: none"> 1. Faulty wire speed control assembly 2. No tension on the drive roller 3. Faulty drive motor (very rare) 	<ol style="list-style-type: none"> 1. Replace wire speed control assembly 2. Adjust the drive tension 3. Replace drive motor
Nothing works except fan	<ol style="list-style-type: none"> 1. Faulty trigger on gun 2. Faulty transformer (rare) 3. Exceeded duty cycle; thermal protector opened 	<ol style="list-style-type: none"> 1. Replace trigger 2. Replace transformer 3. Allow welder to cool at least 10 minutes (observe and maintain proper duty cycle)
Low output or non-penetrating weld.	<ol style="list-style-type: none"> 1. Loose connection inside machine 2. Too long or improper extension cord 3. Wrong type or size wire 4. Poor ground connection 5. Wrong size contact tip 6. Loose gun connection or faulty gun assembly 7. Wrong welding polarity set 8. Dirty or rusty welding wire 	<ol style="list-style-type: none"> 1. Blow inside of machine out with compressed air, clean and tighten all connections 2. See EXTENSION CORD USE in this manual 3. Use correct size welding wire 4. Reposition clamp and check cable to clamp connection 5. Use correct size contact tip 6. Tighten gun or replace gun 7. Change polarity to proper for wire being used 8. Replace spool of wire
Wire is birdnesting at the drive roller	<ol style="list-style-type: none"> 1. Too much tension on drive roller 2. Gun liner worn or damaged 3. Contact tip is clogged or damaged 4. Liner is stretched or is too long 	<ol style="list-style-type: none"> 1. Adjust the drive tension (see INSTALLING THE WELDING WIRE) 2. Replace gun liner 3. Replace contact tip 4. Trim liner to proper length
Wire burns back to contact tip	<ol style="list-style-type: none"> 1. Gun liner is worn or damaged 2. Liner stretched or is too long 3. Wrong size contact tip 4. contact tip clogged or damaged 	<ol style="list-style-type: none"> 1. Replace gun liner 2. Trim liner for proper length 3. Use correct size contact tip 4. Replace contact tip
Ground clamp and/or cable gets hot	Bad connection from cable to clamp	Tighten connection or replace cable
Gun nozzle arcs to work surface	Slag buildup inside nozzle or nozzle is shorted	Clean or replace nozzle as needed

WIRING DIAGRAM

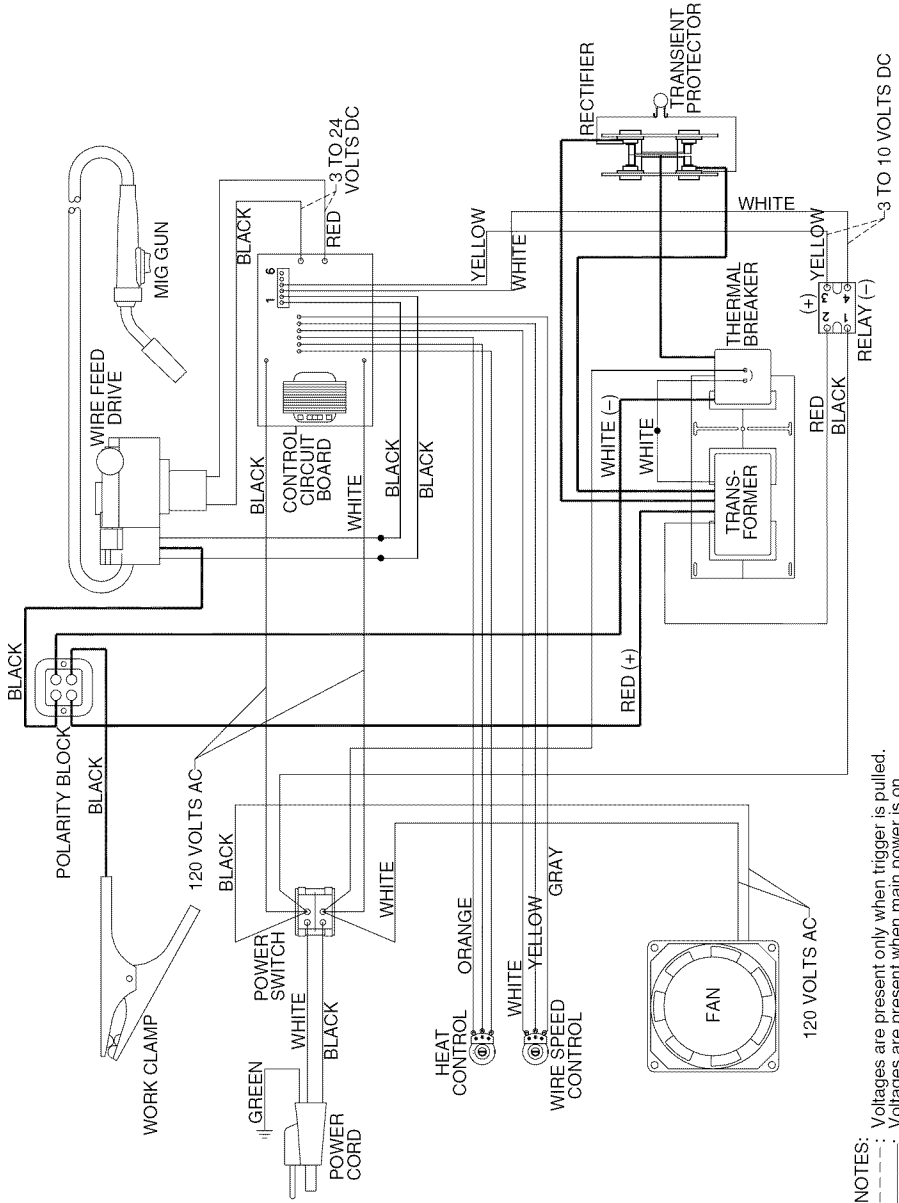

NOTES:
 - Voltages are present only when trigger is pulled.
 - Voltages are present when main power is on.

MODEL 205592

REPLACEMENT PARTS LIST

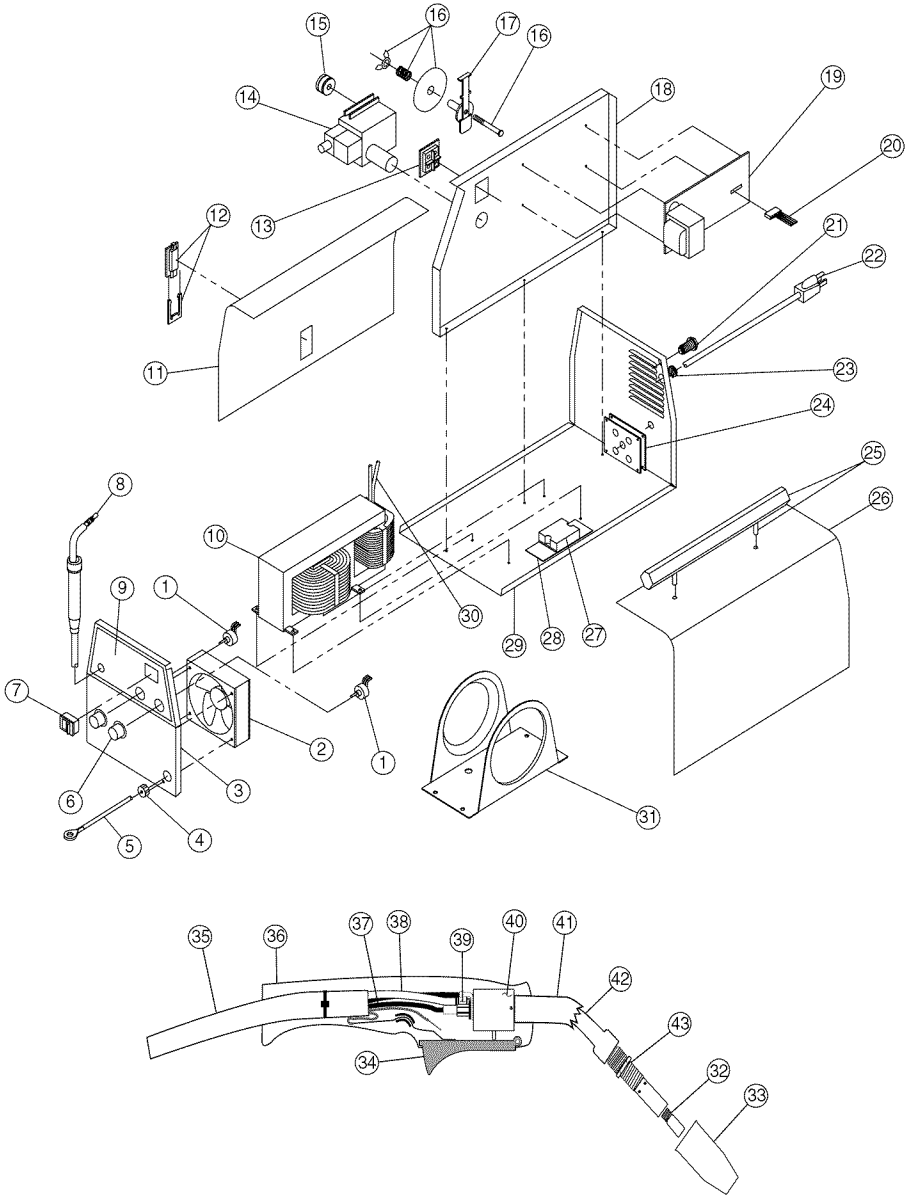

MODEL 205592

ITEM	DESCRIPTION	PART NO.
¥	202082 Sears 105 amp MIG Welder	117-084-902
1	Potentiometer	246-120-000
2	Fan	216-100-000
3	Front Panel	410-900-010
4	Strain Relief	541-057-000
5	Cable Assembly	238-223-666
6	Knob	246-107-666
7	Switch	246-423-000
8	10' MIG gun	238-593-000
9	Control Panel	410-869-011
10	Transformer	880-455-888
11	Left Side Panel	410-865-020
12	Slide Latch W/Clip	312-295-666
13	Terminal Block	246-414-000
14	Wire Feed Motor	880-406-000
15	Steel Drive Roller	310-187-666
16	Tension Hardware	131-419-000
17	Spindle	312-076-666
18	Center Panel	410-960-010
19	Circuit Board	880-456-666
20	Wire Harness	880-425-000
21	Fitting	253-333-000
22	Power Cord	248-351-000
23	Strain Relief	239-074-000
24	Rectifier	880-454-666
25	Handle W/Hardware	312-296-666
26	Right Side Panel	410-864-020
27	Relay	216-055-666
28	Heatsink	412-723-000
29	Base	880-431-000
30	Thermo Breaker	880-435-000
31	Tank Bracket	412-635-010
¥	Trafimet MIG Gun (10 foot cable)	238-593-000
32	Contact Tip 0.024" (0,6 mm)	43090
	Contact Tip 0.030" (0,8 mm)	43100
33	Nozzle	43480
34	Trigger (MIG Gun)	334-440-000
35	Gun Cable, Complete	334-465-000
36	Handle (With Trigger)	334-495-666
37	Gas Hose	059-217-040
38	Liner	334-468-666
39	Gas Hose Quick Connector	334-467-000
¥	Gun Head: Gas Valve, Conductor Tube, Conductor Tube Insulation, Gas Diffuser	334-490-666
40	Gas Valve	334-491-666
41	Conductor Tube Insulation	334-493-666
42	Conductor Tube	334-492-666
43	Gas Diffuser (MIG Gun)	334-494-666
†	Regulator	334-460-000
†	Tube Fitting for Regulator	253-406-666
†	Wire Spool Adapter (for 8")	312-110-666
†	Ground Clamp	239-010-102
†	Welding Face Shield	332-239-666
†	Not Shown In Drawing	
¥	Complete Assembly	

SCHEMATIC

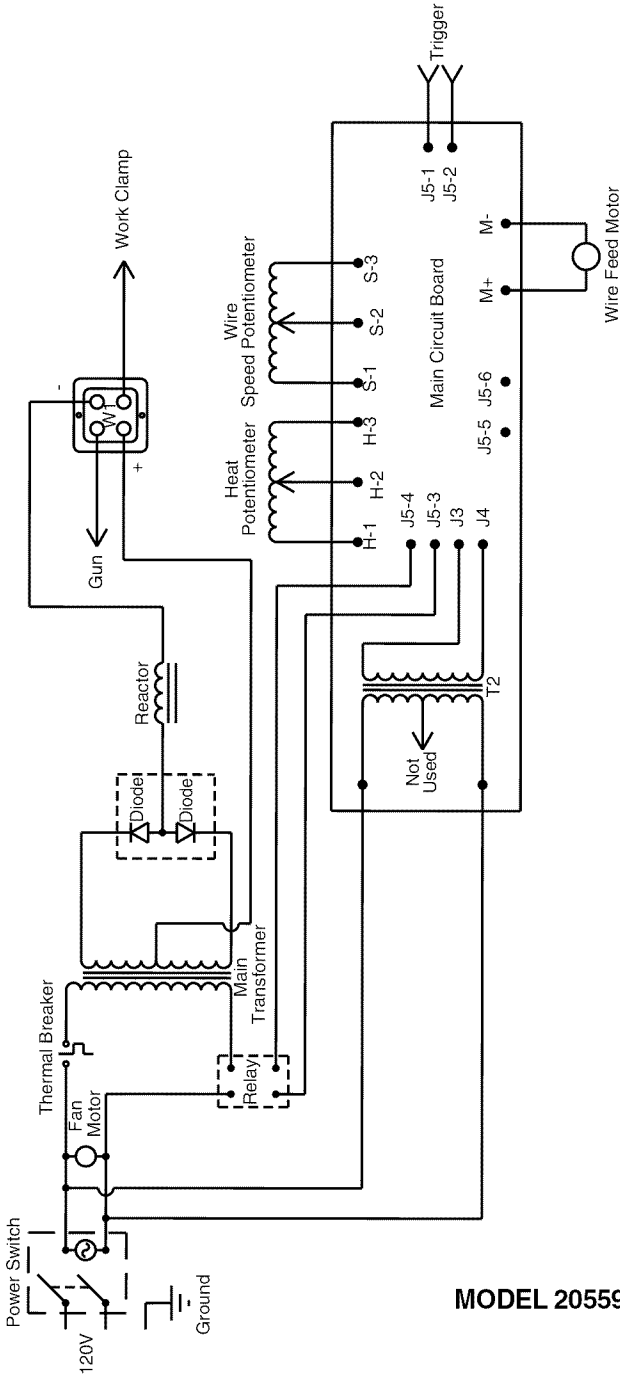

MODEL 205592

**For the repair or replacement parts you need
delivered directly to your home**
Call 7 am - 7 pm, 7 days a week
1-800-366-PART
(1-800-366-7278)

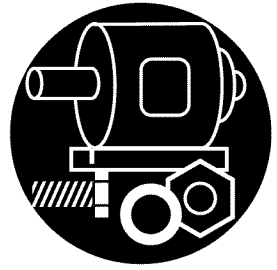

For in-home major brand repair service
Call 24 hours a day, 7 days a week
1-800-4-REPAIR
(1-800-473-7247)



The model number of your product is located on the welder nameplate.
If the parts you need are not stocked locally, your order will be electronically transmitted to a Sears Repair Parts Distribution Center for expedited handling.
When requesting service or ordering parts, always give the following information:

- Product Name
- Model Number
- Part Number
- Part Description

SEARS
REPAIR SERVICES
America's Repair Specialists