

NordicTrack®

VIEWPOINT

Model No. NTL24950

Serial No. _____

Find the serial number in the location shown below. Write the serial number in the space above for reference.

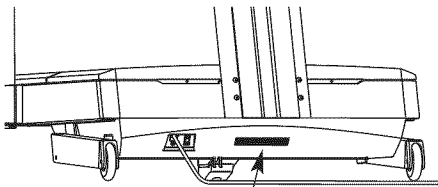

Serial Number Decal

USER'S MANUAL

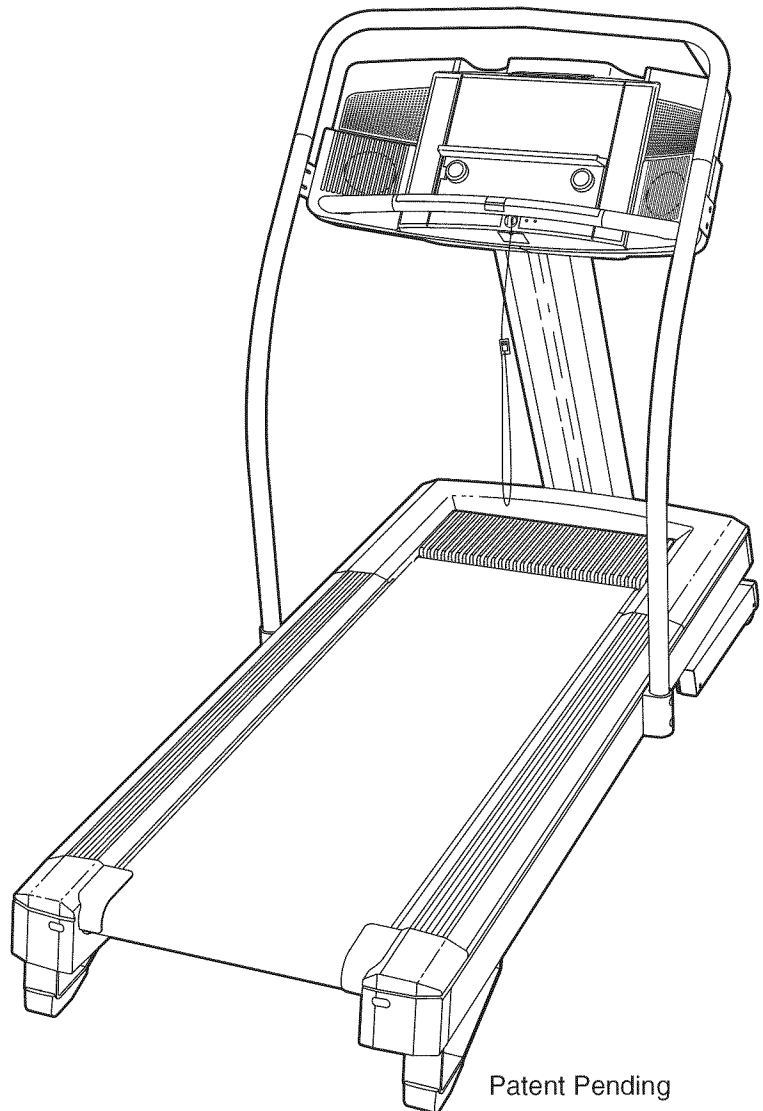

QUESTIONS?

If you have questions, or if there are missing parts, we will guarantee complete satisfaction through direct assistance from our factory.

TO AVOID DELAYS, PLEASE CALL DIRECT TO OUR TOLL-FREE CUSTOMER HOT LINE. The trained technicians on our Customer Hot Line will provide immediate assistance, free of charge to you.

CUSTOMER HOT LINE:

1-888-825-2588

Mon.-Fri., 6 a.m.-6 p.m. MST

CAUTION

Read all precautions and instructions in this manual before using this equipment. Save this manual for future reference.



Visit our website at

www.nordictrack.com

new products, prizes,
fitness tips, and much more!

NordicTrack®

VIEWPOINT

TABLE OF CONTENTS

IMPORTANT PRECAUTIONS	3
BEFORE YOU BEGIN	6
ASSEMBLY	7
OPERATION AND ADJUSTMENT	11
HOW TO MOVE THE TREADMILL	29
TROUBLESHOOTING	30
CONDITIONING GUIDELINES	33
PART LIST	34
ORDERING REPLACEMENT PARTS	35
LIMITED WARRANTY	Back Cover

Note: An EXPLODED DRAWING is attached in the center of this manual.

IMPORTANT PRECAUTIONS

▲ WARNING: To reduce the risk of burns, fire, electric shock, or injury to persons, read the following important precautions and information before operating the treadmill.

1. It is the responsibility of the owner to ensure that all users of this treadmill are adequately informed of all warnings and precautions.
2. Use the treadmill only as described.
3. Place the treadmill on a level surface, with at least eight feet of clearance behind it and two feet on each side. Do not place the treadmill on any surface that blocks air openings. To protect the floor or carpet from damage, place a mat under the treadmill.
4. Keep the treadmill indoors, away from moisture and dust. Do not put the treadmill in a garage or covered patio, or near water.
5. Do not operate the treadmill where aerosol products are used or where oxygen is being administered.
6. Keep children under the age of 12 and pets away from the treadmill at all times.
7. The treadmill should not be used by persons weighing more than 350 pounds.
8. Never allow more than one person on the treadmill at a time.
9. Wear appropriate exercise clothes when using the treadmill. Do not wear loose clothes that could become caught in the treadmill. Athletic support clothes are recommended for both men and women. *Always wear athletic shoes. Never use the treadmill with bare feet, wearing only stockings, or in sandals.*
10. When connecting the power cord (see page 11), plug the power cord into a surge suppressor (not included) and plug the surge suppressor into a grounded circuit capable of carrying 15 or more amps. No other appliance should be on the same circuit. Do not use an extension cord.
11. Use only a single-outlet surge suppressor that meets all of the specifications described on page 11. To purchase a surge suppressor, see your local NordicTrack dealer or call 1-888-825-2588 and order part number 146148, or see your local electronics store.
12. Failure to use a properly functioning surge suppressor could result in damage to the control system of the treadmill. If the control system is damaged, the walking belt may change speed, accelerate, or stop unexpectedly, which may result in a fall and serious injury.
13. Keep the power cord and the surge suppressor away from heated surfaces.
14. Never move the walking belt while the power is turned off. Do not operate the treadmill if the power cord or plug is damaged, or if the treadmill is not working properly. (See **BEFORE YOU BEGIN** on page 6 if the treadmill is not working properly.)
15. Never start the treadmill while you are standing on the walking belt. Always hold the handrails while using the treadmill.
16. To protect the treadmill and TV during lightning storms, unplug the power cord from the wall outlet and disconnect the antenna or cable system. This will prevent damage due to lightning and power line surges.
17. The treadmill is capable of high speeds. Adjust the speed in small increments to avoid sudden jumps in speed.
18. The pulse sensor is not a medical device. Various factors, including the user's movement, may affect the accuracy of heart rate readings. The pulse sensor is intended only as an exercise aid in determining heart rate trends in general.
19. Never leave the treadmill unattended while it is running. Always remove the key, unplug the power cord, and switch the reset/off circuit breaker to the off position when the treadmill is not in use. (See the drawing on page 6 for the location of the reset/off circuit breaker.)
20. Do not attempt to move the treadmill until it is properly assembled. (See **ASSEMBLY** on page 7, and **HOW TO MOVE THE TREADMILL** on page 29.) You must be able to safely lift 55 pounds (25 kg) to move the treadmill.

21. Do not change the incline of the treadmill by placing objects under the treadmill.
22. When using iFIT.com programs, an electronic “chirping” sound will alert you when the speed and/or incline of the treadmill is about to change. Always listen for the “chirp” and be prepared. In some instances, the speed and/or incline may change before the personal trainer describes the change.
23. When using iFIT.com programs, you can manually override the speed and incline settings by pressing the speed and incline buttons. However, when the next “chirp” is heard, the speed and/or incline will change to the next settings of the CD or video program.
24. Always remove iFIT.com CDs and videos from your CD player or VCR and disconnect your MP3 player when you are not using them.
25. Inspect and properly tighten all parts of the treadmill regularly.
26. Never insert or drop any object into any opening.
27. **DANGER:** Always unplug the power cord immediately after use, before cleaning the treadmill, and before performing the maintenance and adjustment procedures described in this manual. Never remove the motor hood unless instructed to do so by an authorized service representative. Servicing other than the procedures in this manual should be performed by an authorized service representative only.
28. The treadmill is intended for in-home use only. Do not use the treadmill in any commercial, rental, or institutional setting.
29. If an outside antenna or cable system is connected, be sure that the antenna or cable system is grounded to provide some protection against voltage surges and built-up static charges. Section 810 of the National Electrical Code, ANSI/NFPA No. 70-1984, provides information with respect to proper grounding of the mast and supporting structure, grounding of the lead-in wire to an an-

tenna discharge unit, size of grounding conductors, location of antenna discharge unit, connection to grounding electrodes, and requirements for the grounding electrode.

30. An outside antenna system should not be located in the vicinity of overhead power lines or other electric light or power circuits, or where it can fall into such power lines or circuits. When installing an outside antenna system, extreme care should be taken to keep from touching such power lines or circuits, as contact with them might be fatal.
31. To reduce the risk of electric shock, do not remove the cover or the back of the television. There are no user serviceable parts inside. Refer servicing to qualified service personnel.
32. Upon completion of any service or repairs to the treadmill or the television, ask the service technician to perform safety checks to confirm that the unit is in proper operating condition.
 - Use No. 10 AWG (5.3mm²) copper, No. 8 AWG (8.4mm²) aluminum, No. 17 AWG (1.0mm²) copper-clad steel or bronze wire, or larger as a ground wire.
 - Secure an antenna lead-in and ground wires to the house with stand-off insulators spaced from 4 to 6 feet (1.22 to 1.83m) apart.
 - Mount an antenna discharge unit as close as possible to where the lead-in enters the house.
 - Use a jumper wire not smaller than No. 6 AWG (13.3mm²) copper, or the equivalent when a separate antenna-grounding electrode is used. See NEC Section 810-21 (j).

Note to CATV system installer: This reminder is provided to call the CATV system installer’s attention to Article 820-40 of the NEC that provides guidelines for proper grounding and, in particular, specifies that the cable ground shall be connected to the grounding system of the building, as close to the point of cable entry as practical.

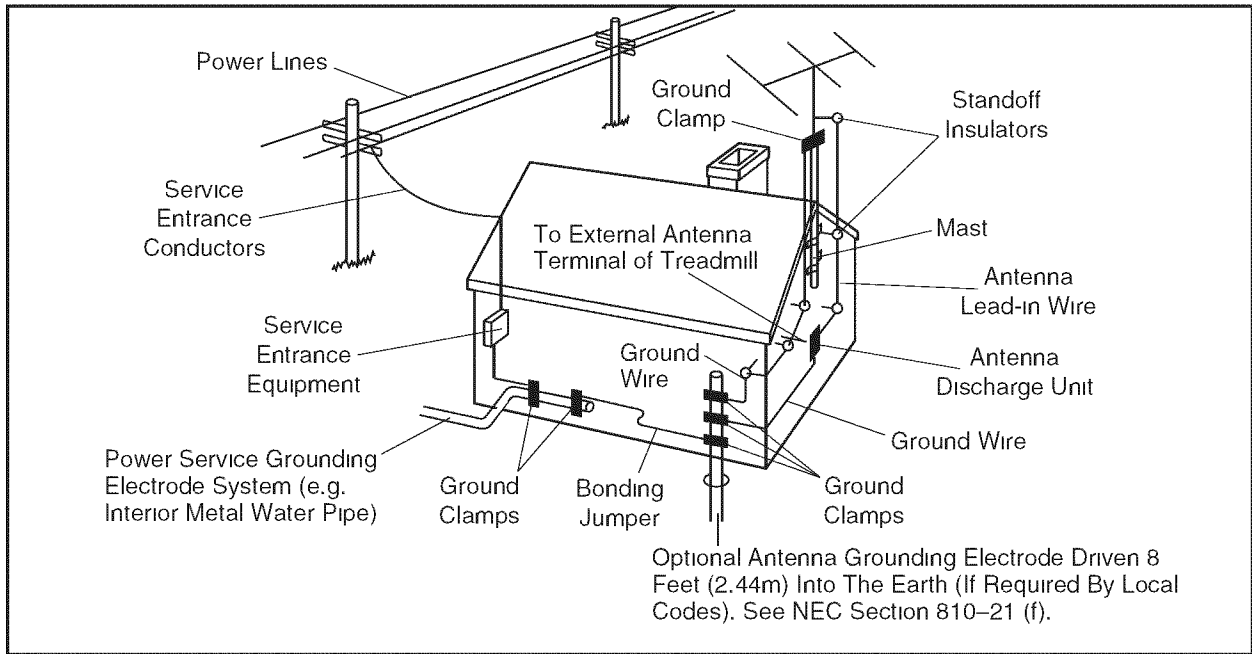

⚠️ WARNING: Before beginning this or any exercise program, consult your physician. This is especially important for persons over the age of 35 or persons with pre-existing health problems. Read all instructions before using. ICON assumes no responsibility for personal injury or property damage sustained by or through the use of this product.

SAVE THESE INSTRUCTIONS

The decal shown has been placed on your treadmill. If the decal is missing or illegible, please call our Customer Service Department, toll-free, to order a free replacement decal (see ORDERING REPLACEMENT PARTS on page 35). Apply the decal in the location shown.

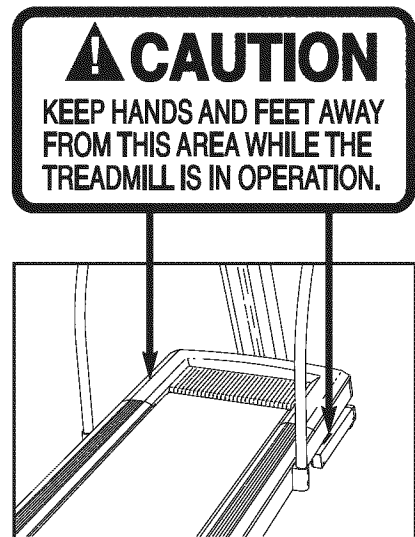

BEFORE YOU BEGIN

Thank you for selecting the revolutionary NordicTrack® VIEW POINT treadmill. The VIEW POINT treadmill offers an impressive array of features designed to make your workouts at home more enjoyable and effective.

For your benefit, read this manual carefully before using the treadmill. If you have questions after reading this manual, please call our Customer Service Department toll-free at 1-888-825-2588, Monday through Friday, 6 a.m. until 6 p.m. Mountain Time (ex-

cluding holidays). To help us assist you, please note the product model number and serial number before calling. The model number of the treadmill is NTL24950. The serial number can be found on a decal attached to the treadmill (see the front cover of this manual for the location).

Before reading further, please familiarize yourself with the parts that are labeled in the drawing below.

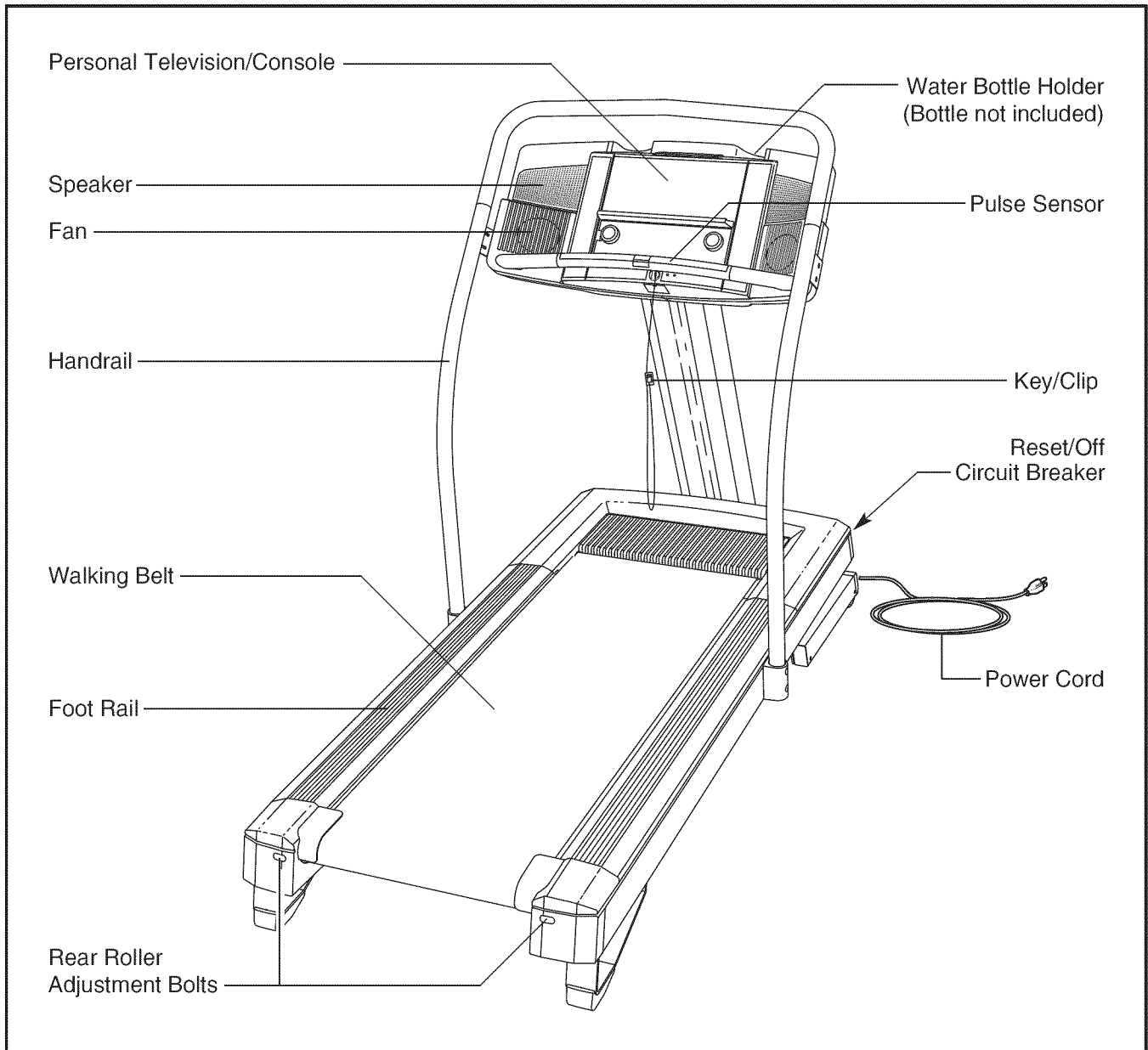

ASSEMBLY

Assembly requires two persons. Set the treadmill in a cleared area and remove all packing materials. **Do not dispose of the packing materials until assembly is completed.**

Note: The underside of the treadmill walking belt is coated with high-performance lubricant. During shipping, a small amount of lubricant may be transferred to the top of the walking belt or the shipping carton. This is a normal condition and does not affect treadmill performance. If there is lubricant on top of the walking belt, simply wipe off the lubricant with a soft cloth and a mild, non-abrasive cleaner.

Assembly requires the included allen wrench  and your own Phillips screwdriver . For help identifying the assembly hardware, see the hardware drawings below.

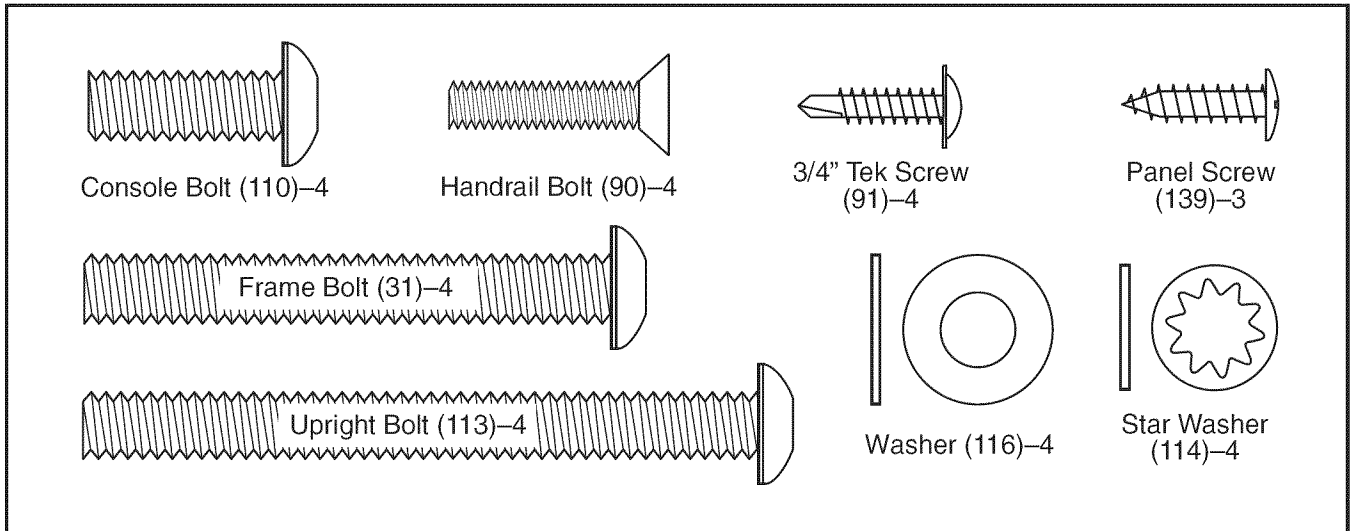

1. Raise the end of the Frame (not shown) until the treadmill can be moved on the front Wheels (66), and carefully roll the treadmill off the wood pallet.

Insert the Wire Harness (108) and the TV Cable (109) through the Upright Plate (115).

With the help of a second person, hold the Upright (111) and the Upright Plate (115) against the Frame Cover (52). **See the inset drawing and make sure that the Upright and the Upright Plate are oriented as shown.** Attach the Upright and the Upright Plate with four Upright Bolts (113) with two Star Washers (114). **Do not tighten the Upright Bolts yet.**

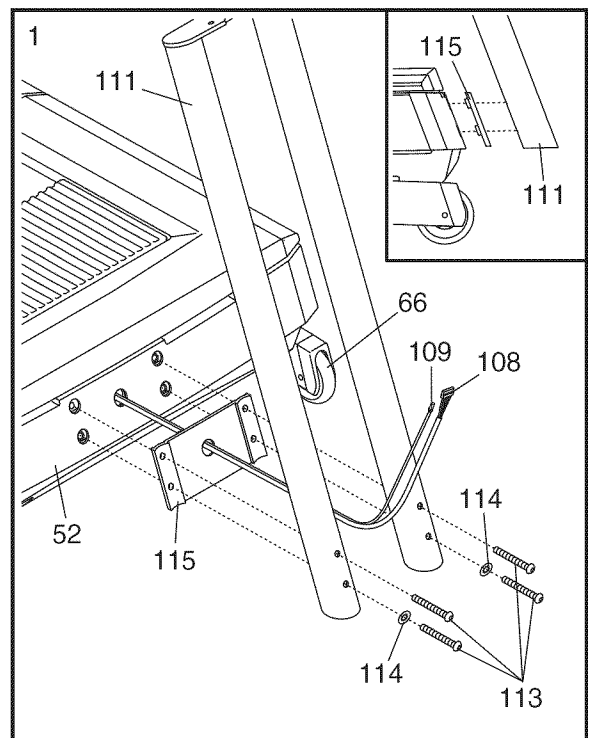

2. Have a second person hold the console assembly near the Upright (111). Insert the cable and the wire harness extending from the console assembly through the hole in the top of the Upright. Attach the console assembly to the Upright with four Console Bolts (110) and two Star Washers (114). **Firmly tighten the four Console Bolts.**

Next, connect the cable and the wire harness extending from the console assembly to the TV Cable (109) and the Wire Harness (108). **The connectors should slide together easily and snap into place. If they do not, turn one connector and try again.**

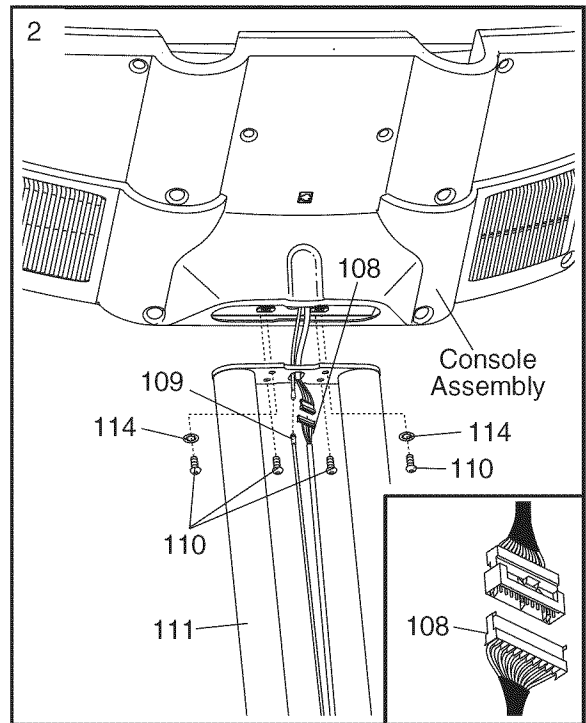

3. **Note: For clarity, the console assembly is not shown in this step.**

Orient the Short Panel (106) so that the indicated cutouts are at the top. Have a second person hold the Short Panel against the Upright (111), **with the top of the Short Panel flush with the top of the Upright**. Route the TV Cable (109) down one side of the Short Panel, and route the Wire Harness (108) down the other side of the Short Panel, as shown.

Next, hold the Long Panel (112) against the opposite side of the Upright (111); **make sure that the top of the Long Panel is flush with the top of the Upright and that no wires are pinched**. Press the Long Panel and the Short Panel (106) together, and align the three holes in the Long Panel with the holes in the three Panel Brackets (140). Attach the Long Panel and the Short Panel with three Panel Screws (139).

Firmly tighten the four Upright Bolts (113).

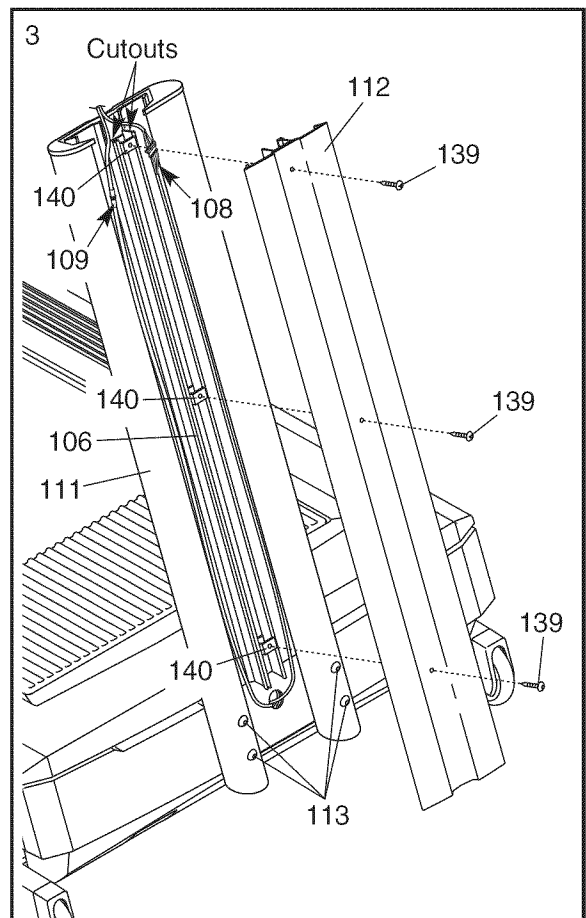

4. Identify the right Handrail (86) and the Left Handrail (89); the Handrails have indented holes in the outer sides for the heads of the Handrail Bolts (90).

Hold the Right Handrail (86) on the right side of the treadmill. Loosely thread two Handrail Bolts (90) into the bracket on the Right Handrail and into the console assembly. **Do not tighten the Handrail Bolts yet.** Attach the Left Handrail to the left side of the treadmill in the same way. Then, slide the Upper Handrail (93) onto the Right and Left Handrails.

Next, slide a Handrail Bracket (32) onto the lower end of the Right Handrail (86). Insert two Frame Bolts (31) with two Washers (116) into the Right Handrail and the Handrail Bracket, and finger tighten the Frame Bolts into the Frame (28). **Do not tighten the Frame Bolts yet.** Attach the lower end of the Left Handrail (89) in the same way.

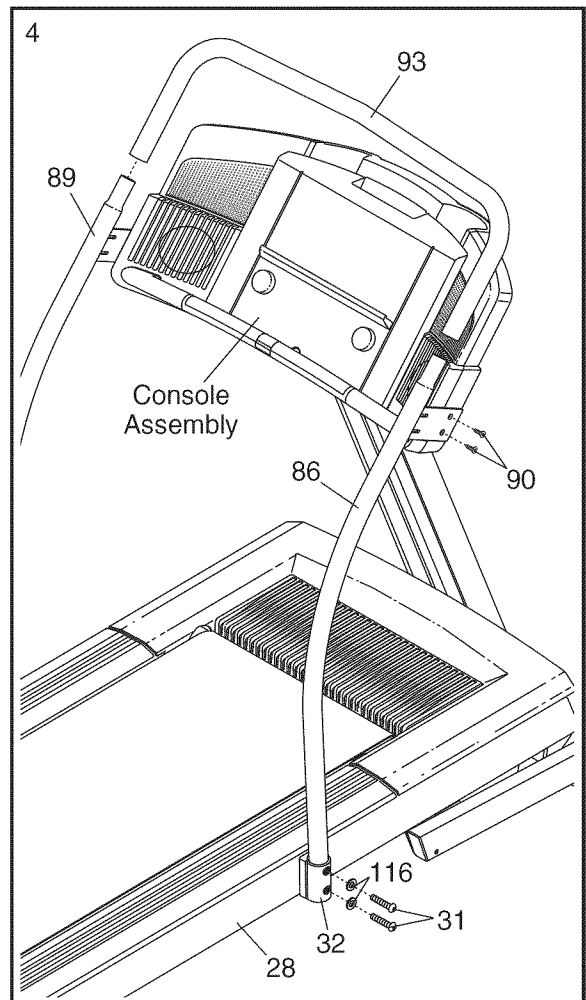

5. Attach the Upper Handrail (93) to the Left and Right Handrails (86, 89) with four 3/4" Tek Screws (91) (only two are shown); **start all four Tek Screws before tightening them.**

See step 4. Firmly tighten the four Handrail Bolts (90) and the four Frame Bolts (31).

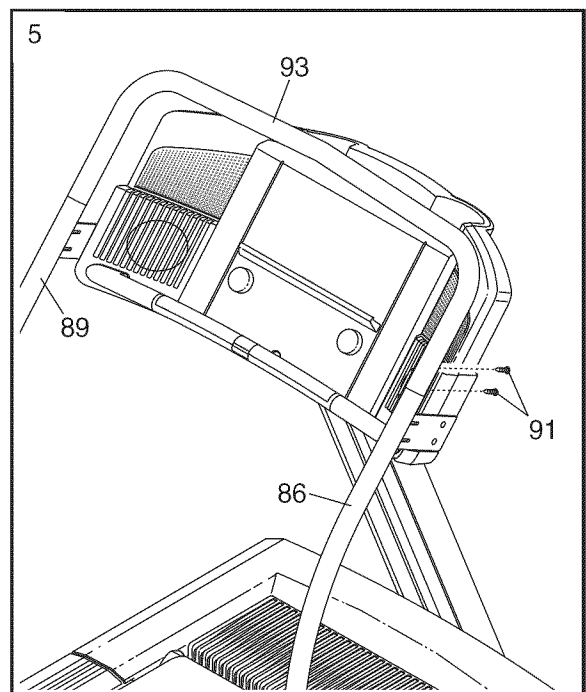

6. **Note the location of the 75 ohm antenna terminal on the treadmill. For the television to operate properly, an antenna, a CATV cable, or a VCR must be connected to the 75 ohm antenna terminal.**

If you are using an antenna, it must be properly connected and adjusted for optimal reception. See ANTENNA CONNECTIONS on page 26 to properly connect an antenna. **If you are using a CATV cable**, see CATV CABLE CONNECTION on page 26 to properly connect the cable. **If you are using a VCR**, see HOW TO CONNECT A VCR on page 27 to properly connect the VCR. **The VCR must be turned on, a videocassette must be properly inserted, and the VCR must be playing. See your VCR user's manual for operating instructions.**

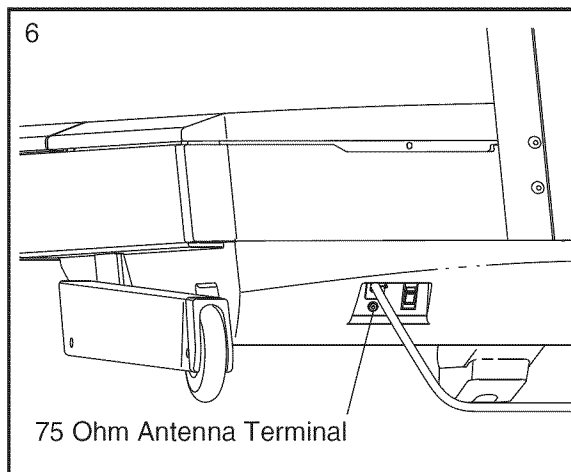

7. Remove the battery cover from the back of the Remote Control (137). Insert two "AAA" batteries (not included) into the battery compartment; **make sure that the batteries are oriented as shown by the diagram inside of the battery compartment.** Reattach the battery cover.

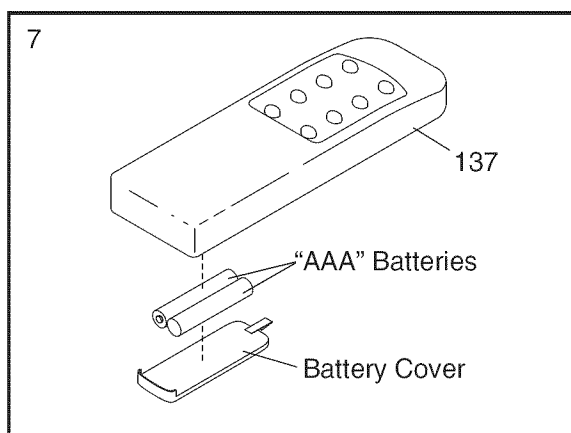

8. **Make sure that all parts are properly tightened before you use the treadmill.** Keep the included allen wrenches in a secure place. The allen wrench is used to adjust the walking belt (see page 31). **To protect the floor or carpet from damage, place a mat under the treadmill.**

If you purchase the optional chest pulse sensor (see page 12), follow the steps below to install the receiver included with the chest pulse sensor.

1. **Make sure that the power cord is unplugged.**
2. Remove the indicated 3/4" Screw (95) and the Access Door (121) from the bottom of the Console Base (98).
3. Connect the wire on the receiver (A) to the indicated wire extending from the Console Base (98). **Hold the receiver so the small cylinder is oriented as shown and is facing the Console Back.** Attach the receiver to the plastic posts on the Access Door (121) with the two included small screws.
4. **Make sure that no wires are pinched.** Reattach the Access Door (121) with the 3/4" Screw (95). Discard the other wires included with the receiver.

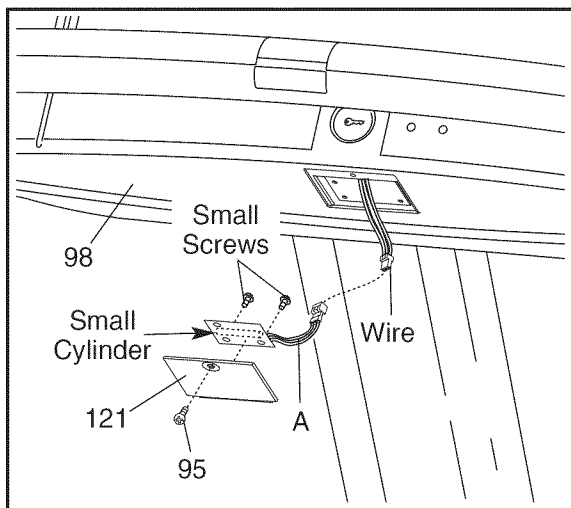

OPERATION AND ADJUSTMENT

THE PRE-LUBRICATED WALKING BELT

Your treadmill features a walking belt coated with high-performance lubricant. **IMPORTANT: Never apply silicone spray or other substances to the walking belt or the walking platform. Such substances will deteriorate the walking belt and cause excessive wear.**

HOW TO PLUG IN THE POWER CORD

⚠ DANGER: Improper connection of the equipment-grounding conductor can result in an increased risk of electric shock. Check with a qualified electrician or serviceman if you are in doubt as to whether the product is properly grounded. Do not modify the plug provided with the product—if it will not fit the outlet, have a proper outlet installed by a qualified electrician.

Your treadmill, like any other type of sophisticated electronic equipment, can be seriously damaged by sudden voltage changes in your home's power. Voltage surges, spikes, and noise interference can result from weather conditions or from other appliances being turned on or off. **To decrease the possibility of your treadmill being damaged, always use a surge suppressor with your treadmill (see drawing 1 at the right).** To purchase a surge suppressor, see your local NordicTrack dealer or call 1-888-825-2588 and order part number 146148, or see your local electronics store.

Use only a single-outlet surge suppressor that is UL 1449 listed as a transient voltage surge suppressor (TVSS). The surge suppressor must have a UL suppressed voltage rating of 400 volts or less and a minimum surge dissipation of 450 joules. The surge suppressor must be electrically rated for 120 volts AC and 15 amps. There must be a monitoring light on the surge suppressor to indicate whether it is functioning properly. Failure to use a properly functioning surge suppressor could result in damage to the control system of the treadmill. If the control system is damaged, the walking belt may change speed, accelerate, or stop unexpectedly, which may result in a fall and serious injury.

This product must be grounded. If it should malfunction or break down, grounding provides a path of least resistance for electric current to reduce the risk of elec-

tric shock. This product is equipped with a cord having an equipment-grounding conductor and a grounding plug. **Plug the power cord into a surge suppressor, and plug the surge suppressor into an appropriate outlet that is properly installed and grounded in accordance with all local codes and ordinances. Important: The treadmill is not compatible with GFCI-equipped outlets.**

This product is for use on a nominal 120-volt circuit, and has a grounding plug that looks like the plug illustrated in drawing 1 below. A temporary adapter that looks like the adapter illustrated in drawing 2 may be used to connect the surge suppressor to a 2-pole receptacle as shown in drawing 2 if a properly grounded outlet is not available.

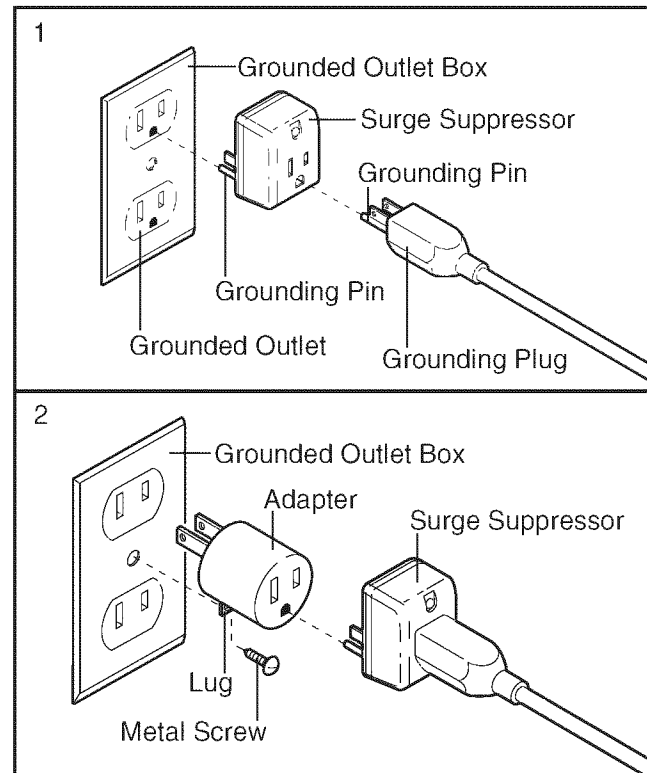

The temporary adapter should be used only until a properly grounded outlet (drawing 1) can be installed by a qualified electrician.

The green-colored rigid ear, lug, or the like extending from the adapter must be connected to a permanent ground such as a properly grounded outlet box cover. Whenever the adapter is used it must be held in place by a metal screw. **Some 2-pole receptacle outlet box covers are not grounded. Contact a qualified electrician to determine if the outlet box cover is grounded before using an adapter.**

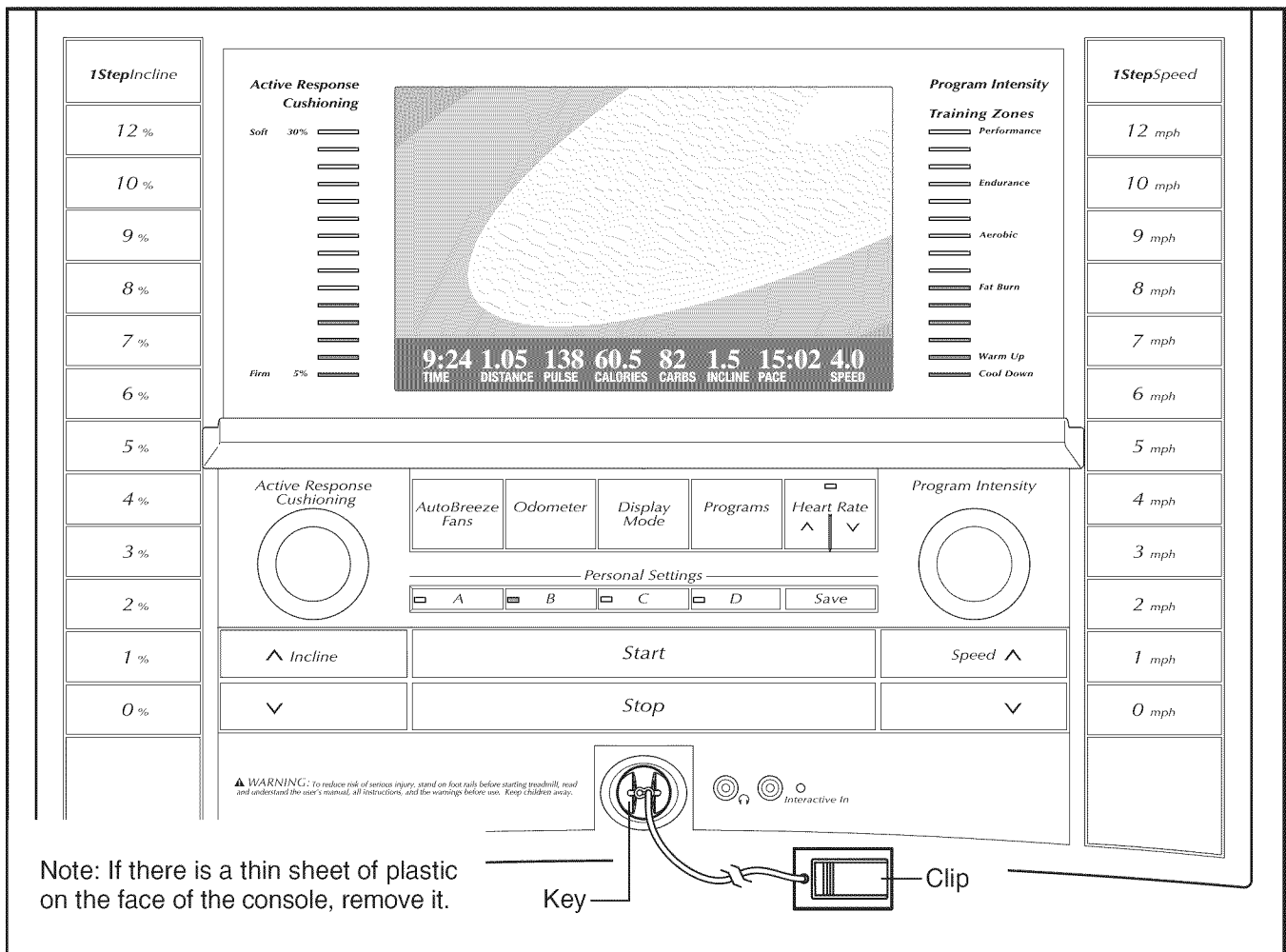

Note: If there is a thin sheet of plastic on the face of the console, remove it.

FEATURES OF THE CONSOLE

The treadmill console offers an impressive array of features designed to make your workouts more effective and enjoyable. When the manual mode of the console is selected, the speed and incline of the treadmill can be changed with the touch of a button. As you exercise, the console will display continuous exercise information. You can even measure your heart rate using the built-in handgrip pulse sensor or the optional chest pulse sensor. **To purchase a chest pulse sensor, call toll-free 1-888-825-2588.**

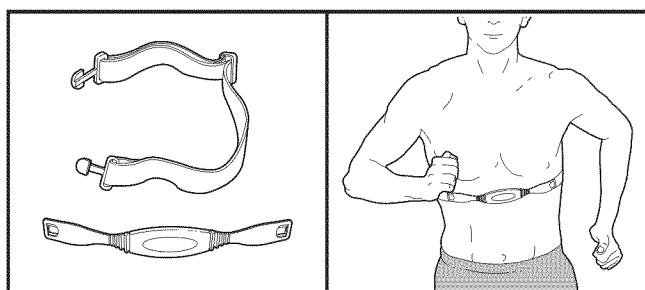

The console also features twenty-five preset programs that automatically control the speed and incline of the treadmill as they guide you through effective workouts. You can even create custom workout programs and save them in memory for future use. In addition, the console offers four pulse programs that control the speed and incline of the treadmill to keep your heart rate near a target heart rate during your workouts.

Whether you select the manual mode or use a program, you can enjoy the personal television while you get in shape.

The console also features iFIT.com interactive technology. Having iFIT.com technology is like having a personal trainer in your home. Using a stereo audio cable, you can connect the treadmill to your portable stereo, home stereo, computer, or VCR and play special iFIT.com MP3, CD, and video programs (iFIT.com MP3 programs, CDs, and videocassettes are available separately). iFIT.com programs automatically control the speed and incline of the treadmill as a personal trainer

guides you through every step of your workout; high-energy music provides added motivation. **To purchase and download iFIT.com MP3 programs, go to www.iFIT.com. To purchase iFIT.com CDs or video-cassettes, call toll-free 1-888-825-2588.**

With the treadmill connected to your computer, you can also go to www.iFIT.com and access iFIT.com programs directly from our Web site. See www.iFIT.com for more information.

To use the manual mode of the console, follow the steps beginning on page 13. To use a preset program, see page 16. To create and use a custom program, see pages 17 and 18. To use a pulse program, see page 19. To use an iFIT.com MP3, CD, or video program, see page 23. To use an iFIT.com program directly from our Web site, see page 25.

To operate the personal television, follow the steps beginning on page 26. IMPORTANT: For the television to operate properly, an antenna, a CATV cable, or a VCR must be connected to the 75 ohm antenna terminal on the treadmill.

HOW TO TURN ON THE POWER

Plug in the power cord (see page 11).

Next, locate the reset/off circuit breaker near the power cord. Make sure that the circuit breaker is in the reset position.

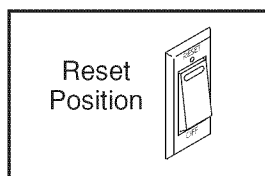

Stand on the foot rails of the treadmill. Find the clip attached to the key (see the drawing on page 12) and attach the clip securely to the waistband of your clothes. Next, insert the key into the console. After a moment, the screen will light. **Test the clip by carefully taking a few steps backward until the key is pulled from the console. If the key is not pulled from the console, adjust the position of the clip as needed.**

HOW TO USE THE MANUAL MODE

1 Insert the key into the console.

See HOW TO TURN ON THE POWER at the left.

2 Designate yourself as user A, B, C, or D.

The console can save settings for up to four different users. To designate yourself as user A, B, C, or D, press the Personal Settings button labeled A, B, C, or D. When the button is pressed, any settings that you have saved will automatically be selected, and the program that was selected the last time you pressed the Save button will automatically be reselected.

3 Select the manual mode.

If the manual mode is not selected, press the Programs button repeatedly until the words "Manual Mode" appear on the screen.

4 Start the walking belt.

To start the walking belt, press the Start button, the Speed increase button, or one of the twelve 1-Step Speed buttons.

If the Start button or the Speed increase button is pressed, the walking belt will begin to move at 1 mph. Change the speed of the walking belt as desired by pressing the Speed increase and decrease buttons. Each time a button is pressed, the speed setting will change by 0.1 mph; if a button is held down, the speed setting will change in increments of 0.5 mph. Note: After the buttons are pressed, it may take a moment for the walking belt to reach the selected setting.

If one of the 1-Step Speed buttons is pressed, the walking belt will gradually increase in speed until it reaches the selected setting.

To stop the walking belt, press the Stop button. If the time is displayed on the screen, the time will begin to flash. To restart the walking belt, press the Start button, the Speed increase button, or one of the 1-Step Speed buttons.

Note: The speed of the treadmill can also be controlled with the remote control. See HOW TO USE THE REMOTE CONTROL on page 28.

5 Change the incline of the treadmill as desired.

To change the incline of the treadmill, press the Incline increase and decrease buttons or one of the twelve 1-Step Incline buttons.

Each time the Incline increase or decrease button is pressed, the incline will change by 0.5%. If one of the 1-Step Incline buttons is pressed, the incline will gradually increase until it reaches the selected setting.

Note: The incline of the treadmill can also be controlled with the remote control. See HOW TO USE THE REMOTE CONTROL on page 28.

6 Adjust the cushioning system as desired.

The treadmill features a cushioning system that reduces the impact as you walk or run on the treadmill. There are fifteen firmness levels. To increase the firmness of the walking platform, turn the Active Response Cushioning dial counterclockwise. To decrease the firmness, turn the dial clockwise. The Active Response Cushioning display will show the selected firmness level. If you wish to save the firmness level, press the Save button. Note: A clicking sound may be heard when the cushioning system is being adjusted.

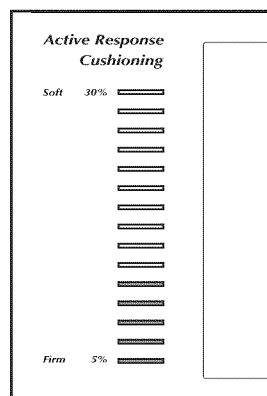

7 Select a display mode and follow your progress with the exercise information on the screen and in the Training Zone display.

As you walk or run on the treadmill, the screen can display the following exercise information:

- The elapsed time. Note: When a program is selected (except for a custom program), the screen will show the time remaining in the program instead of the elapsed time.
- The distance that you have walked or run. Note: To see the number of miles that you have walked or run during a recent period of time, such as the most recent month, press the

Odometer button; the words “My Distance” and the number of miles will appear on the screen. To reset this number, hold down the Odometer button for a few seconds. The screen will also show the words “Total Distance” and the total number of miles that you have walked or run since the treadmill was purchased. Note: The console can display distance and speed in either miles or kilometers (see HOW TO USE THE INFORMATION MODE on page 28). **For simplicity, all instructions in this section refer to miles.**

- Your heart rate. Note: Your heart rate will be displayed only when you use the handgrip pulse sensor or the optional chest pulse sensor.
- The approximate number of calories you have burned.
- The incline level of the treadmill.
- Your walking or running pace, in minutes per mile.
- The approximate number of grams of carbs you have burned.
- The speed of the walking belt.

While the television is off, all of the above exercise information will be displayed on the screen. While the television is on, the display mode that you select will determine which information is displayed—some or all of the information can be displayed on the right side, the bottom, or the left side of the screen. Or, the information can be turned off while you watch the television. Press the Display Mode button repeatedly to select the desired display mode.

As you exercise, the Training Zones display will indicate the approximate intensity level of your exercise. For example, if six indicators in the display are lit, the display shows that your intensity level is ideal for fat burning.

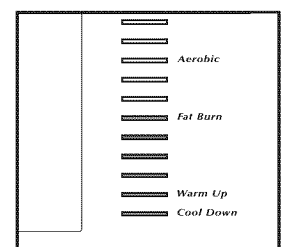

To reset the console, press the Stop button, remove the key, and then reinsert the key.

8 Measure your heart rate if desired.

Note: If you use the handgrip pulse sensor and the optional chest pulse sensor at the same time, the console will not display your

heart rate accurately. Before using the handgrip pulse sensor, remove the clear plastic film from the metal contacts on the handgrip pulse sensor. In addition, make sure that your hands are clean.

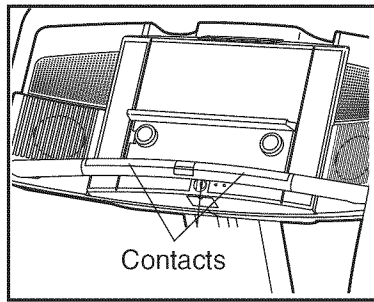

To use the handgrip pulse sensor, **stand on the foot rails** and hold the pulse sensor with your palms resting on the metal contacts closest to you; **avoid moving your hands**. When your pulse is detected, the words "Heart Rate" and your heart rate will appear on the screen. **For the most accurate heart rate reading, continue to hold the contacts for about 15 seconds.**

9 Turn on the fans if desired.

To turn on the fans at low speed, press the AutoBreeze Fans button; the words "Fan Speed: Low" will appear on the screen. To turn on the fans at medium speed, press the button a second time; the words "Fan Speed: Medium" will appear.

To turn on the fans at high speed, press the button a third time; the words "Fan Speed: High" will appear. To select the Auto mode, press the button again; the words "Fan Speed: Auto" will appear. When the auto mode is selected, the speed of the fans will automatically increase or decrease as the speed of the walking belt increases or decreases.

To turn off the fans, press the AutoBreeze Fans button again; the words "Fan Speed: Off" will appear. Note: If the fans are left on when the walking belt is stopped, the fans will automatically turn off after a few minutes.

10 When you are finished exercising, remove the key from the console.

Step onto the foot rails, press the Stop button, and adjust the incline of the treadmill to the lowest setting. Next, remove the key from the console and put it in a secure place. **Note: If the screen remains on after the key is removed, the console is in the "demo" mode. See HOW TO USE THE INFORMATION MODE on page 28 and turn off the demo mode.**

When you are finished using the treadmill, switch the reset/off circuit breaker to the "off" position and unplug the power cord.

Note: The first time the treadmill is used, observe the alignment of the walking belt, and align the walking belt if necessary (see page 31).

HOW TO USE A PRESET PROGRAM

1 Insert the key into the console.

See HOW TO TURN ON THE POWER on page 13.

2 Identify yourself as user A, B, C, or D.

See step 2 on page 13.

3 Select one of the preset programs.

To select one of the twenty-five preset programs, press the Programs button repeatedly.

As each preset program is selected, the name of the program (such as "Small Hill"), the maximum speed and incline settings of the program, and the total program time will appear on the screen. In addition, a diagram of the program will appear; the blue-green profile represents the speed settings of the program, and the white line represents the incline settings. The red arrow below the diagram will indicate your progress.

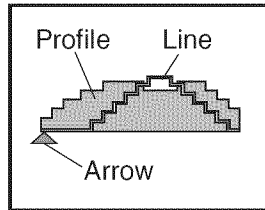

4 Adjust the intensity level of the program if desired.

When a preset program is selected, the Program Intensity display (the Training Zones display) will show the intensity level of the selected program. There are fifteen intensity levels. If desired, turn the Program Intensity dial to increase or decrease the intensity level of the program. If you change the intensity level, the current intensity level and the average intensity level of the program will be shown on the screen for a few seconds, and then the new maximum speed and incline settings of the program will appear. If you wish to save the new intensity level, press the Save button.

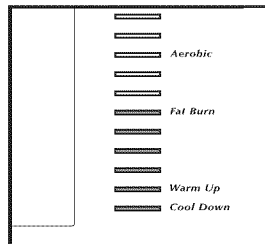

5 Press the Start button or the Speed increase button to start the program.

A moment after the button is pressed, the treadmill will automatically adjust to the first speed and incline settings of the program. Hold the handrails and begin walking.

Each program is divided into several time segments of different lengths. One speed setting and one incline setting are programmed for each segment. Note: The same speed setting and/or incline setting may be programmed for two or more consecutive segments.

When only three seconds remain in the first segment of the program, a series of tones will sound. If the speed and/or the incline of the treadmill is about to change, the speed setting and/or the incline setting will flash on the screen to alert you. When the first segment ends, the red arrow below the program diagram will move one position to the right. Note: Regardless of which display mode is selected, the speed setting, the incline setting, and the program diagram will appear on the screen at the end of each segment.

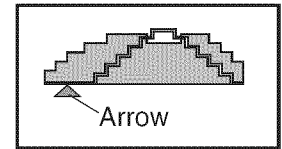

When the first segment ends, the treadmill will automatically adjust to the speed and incline settings for the second segment.

The program will continue in this way until the red arrow reaches the right end of the program diagram. The walking belt will then slow to a stop.

If the speed setting and/or the incline setting is too high or too low during the program, you can change the intensity level of the program at any time by turning the Program Intensity dial. If you wish to save the new intensity level, press the Save button.

To stop the program at any time, press the Stop button. If the time is displayed on the screen, the time will begin to flash. To restart the program, press the Start button or the Speed increase button. The walking belt will begin to move at 1 mph. When the next segment of the program begins, the treadmill will automatically adjust to the speed and incline settings for the next segment.

6 Adjust the cushioning system as desired.

See step 6 on page 14.

7 Select a display mode and follow your progress with the exercise information on the screen.

See step 7 on page 14.

8 Measure your heart rate if desired.

See step 8 on page 15.

9 Turn on the fans if desired.

See step 9 on page 15.

10 When you are finished exercising, remove the key from the console.

See step 10 on page 15.

HOW TO CREATE A CUSTOM PROGRAM

1 Insert the key into the console.

See HOW TO TURN ON THE POWER on page 13.

2 Identify yourself as user A, B, C, or D.

See step 2 on page 13.

3 Select one of the custom programs.

To select a custom program, press the Programs button repeatedly until the words “My Design #1,” “My Design #2,” “My Design #3,” or “My Design #4” appear on the screen.

Note: If the custom program has not yet been designed, a program time of three minutes will appear on the screen. If the program time is more than three minutes, see HOW TO USE A CUSTOM PROGRAM on page 18.

4 Press the Start button or the Speed increase button and program the desired speed and incline settings.

A moment after the button is pressed, the walking belt will begin to move. Hold the handrails and begin walking.

Each custom program is divided into one-minute segments. One speed setting and one incline setting can be programmed for each segment. To program a speed setting and an incline setting for the first segment, simply adjust the speed and incline of the treadmill as desired by pressing the Speed and Incline buttons.

When the first segment of the program ends, a series of tones will sound and the current speed setting and the current incline setting will be saved in memory. Program a speed setting and an incline setting for the second segment as described above.

Continue programming speed and incline settings for as many segments as desired; custom programs can have up to forty segments. When you are finished with your workout, press the Stop button twice. The speed and incline settings that you have programmed and the program time will then be saved in memory.

5 Adjust the cushioning system as desired.

See step 6 on page 14.

6 Select a display mode and follow your progress with the exercise information on the screen.

See step 7 on page 14.

7 Measure your heart rate if desired.

See step 8 on page 15.

8 Turn on the fans if desired.

See step 9 on page 15.

9 When you are finished exercising, remove the key from the console.

See step 10 on page 15.

HOW TO USE A CUSTOM PROGRAM

1 Insert the key into the console.

See HOW TO TURN ON THE POWER on page 13.

2 Identify yourself as user A, B, C, or D.

See step 2 on page 13.

3 Select one of the custom programs.

To select a custom program, press the Programs button repeatedly until the words “My Design #1,” “My Design #2,” “My Design #3,” or “My Design #4” appear on the screen.

As each custom program is selected, the maximum speed and incline settings of the program and the total program time will appear on the screen. **Note: If the program time is only three minutes, see HOW TO CREATE A CUSTOM PROGRAM on page 17.**

4 Press the Start button or the Speed increase button to start the program.

A moment after the button is pressed, the treadmill will automatically adjust to the first speed and incline settings that you programmed previously. Hold the handrails and begin walking.

Each custom program is divided into several one-minute segments. One speed setting and one incline setting are programmed for each segment. **Note:** The same speed setting and/or incline setting may be programmed for two or more consecutive segments.

When only three seconds remain in the first segment of the program, a series of tones will sound. If the speed and/or the incline of the treadmill is about to change, the speed setting and/or the incline setting will flash on the screen to alert you. **Note:** Regardless of which display mode is selected, the speed setting and the incline setting will appear on the screen at the end of each segment.

When the first segment ends, the treadmill will automatically adjust to the speed and incline settings for the second segment.

The program will continue in this way until the last segment ends. The walking belt will then slow to a stop.

If desired, you can redesign the program while using it. **To change the speed setting or the incline setting for the current segment**, simply press the Speed or Incline buttons. When the current segment ends, the new setting will be saved in memory. **To increase the length of the program**, first wait until the program is completed. Then, press the Start button and program speed and incline settings for as many additional segments as desired. When you have added as many segments as desired, press the Stop button twice. **To decrease the length of the program**, press the Stop button twice at any time before the program is completed.

To stop the program at any time, press the Stop button. If the time is displayed on the screen, the time will begin to flash. To restart the program, press the Start button or the Speed increase button. The walking belt will begin to move at 1 mph. When the next segment of the program begins, the treadmill will automatically adjust to the speed and incline settings for the next segment.

5 Adjust the cushioning system as desired.

See step 6 on page 14.

6 Select a display mode and follow your progress with the exercise information on the screen.

See step 7 on page 14.

7 Measure your heart rate if desired.

See step 8 on page 15.

8 Turn on the fans if desired.

See step 9 on page 15.

9 When you are finished exercising, remove the key from the console.

See step 10 on page 15.

HOW TO USE A PULSE PROGRAM

⚠ CAUTION: If you have heart problems, or if you are over 60 years of age and have been inactive, do not use the pulse programs. If you are taking medication regularly, consult your physician to find whether the medication will affect your exercise heart rate.

Follow the steps below to use a pulse program.

1 Insert the key into the console.

See HOW TO TURN ON THE POWER on page 13.

2 Identify yourself as user A, B, C, or D.

See step 2 on page 13.

3 Select a pulse program.

To select a pulse program, press the Programs button repeatedly until the words "Pulse Program #1," "Pulse Program #2," "Pulse Program #3," or "Pulse Program #4" appear on the screen.

As each pulse program is selected, the words "Max Heart Rate" and the current maximum target heart rate setting of the program will appear on the screen. In addition, a diagram that represents the target heart rate settings of the program will appear. The red arrow below the diagram indicates your progress.

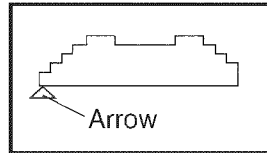

4 Enter a maximum target heart rate setting.

To change the maximum target heart rate setting of the program, press the Heart Rate increase or decrease button. (**Note: See the heart rate chart on page 33 for heart rate guidelines.**) To save the new setting, press the Save button.

5 Press the Start button or the Speed increase button to start the program.

A moment after the button is pressed, the treadmill will automatically adjust to the first speed and

incline settings of the program. Hold the handrails and begin walking.

Each pulse program is divided into either 20 or 30 one-minute segments. One target heart rate is programmed for each segment. Note: The same target heart rate may be programmed for two or more consecutive segments.

To use a pulse program, you must hold the handgrip pulse sensor or wear the optional chest pulse sensor. If you use the handgrip pulse sensor, it is not necessary to hold the pulse sensor continuously; however, you should hold the pulse sensor frequently for the program to operate properly. **Each time you hold the pulse sensor, keep your hands on the metal contacts for at least 30 seconds.**

During each segment, the console will compare your heart rate to the target heart rate setting for that segment. If your heart rate is too far below or above the target heart rate setting, the speed of the walking belt will automatically increase or decrease to bring your heart rate closer to the target heart rate setting. If the speed reaches the maximum speed setting of the program (7.5 mph) and your heart rate is still too far below the target heart rate setting, the incline of the treadmill will also increase. Each time the speed and/or the incline of the treadmill is about to change, the speed setting and/or the incline setting will flash on the screen to alert you. Note: Regardless of which display mode is selected, the speed setting, the incline setting, and the program diagram will appear on the screen each time the speed and/or the incline is about to change.

When only three seconds remain in the first segment of the program, a series of tones will sound. When the first segment ends, the red arrow below the program diagram will move one position to the right.

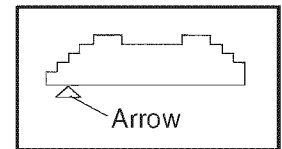

The program will continue in this way until the red arrow reaches the right end of the program diagram. The walking belt will then slow to a stop.

If the speed setting or the incline setting of the program is too high or too low, you can change the intensity level of the program at any time by pressing the Heart Rate increase and decrease buttons to change the maximum target heart rate setting. If you wish to save the new setting, press the Save button.

To stop the program at any time, press the Stop button. If the time is displayed on the screen, the time will begin to flash. To restart the program, press the Start button or the Speed increase button. The walking belt will begin to move at 1 mph. When the console compares your heart rate to the target heart rate setting, the speed and/or the incline of the treadmill will automatically change to bring your heart rate closer to the target heart rate setting.

6 Adjust the cushioning system as desired.

See step 6 on page 14.

7 Select a display mode and follow your progress with the exercise information on the screen.

See step 7 on page 14.

8 Turn on the fans if desired.

See step 9 on page 15.

9 When you are finished exercising, remove the key from the console.

See step 10 on page 15.

HOW TO CONNECT THE TREADMILL TO USE IFIT.COM PROGRAMS

To use iFIT.com MP3 or CD programs, the treadmill must be connected to your MP3 player, CD player, portable stereo, home stereo, or computer. See pages 21 and 22 for connecting instructions. To use iFIT.com programs directly from our Web site, the treadmill must be connected to your computer. See page 22 for connecting instructions. To use iFIT.com video programs, the treadmill must be connected to your VCR. See page 23 for connecting instructions.

HOW TO CONNECT YOUR MP3 PLAYER OR CD PLAYER

- A. Plug one end of the included 1/8" to 1/8" stereo audio cable into the input jack on the console. Plug the other end of the cable into a jack on your MP3 player or CD player. Plug your headphones into the headphone jack on the console.

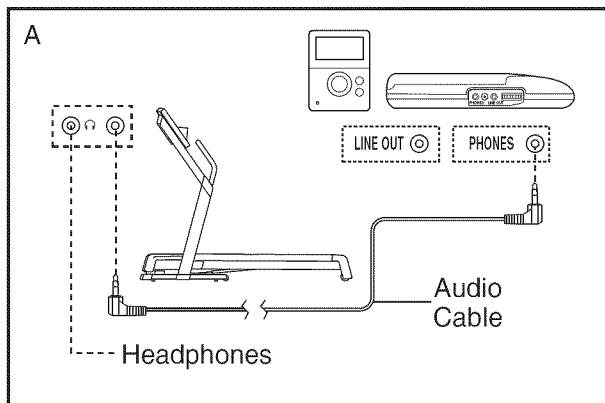

HOW TO CONNECT YOUR PORTABLE STEREO

Note: If your stereo has an RCA-type AUDIO OUT jack, see instruction A below. If your stereo has a 1/8" LINE OUT jack, see instruction B. If your stereo has only a PHONES jack, see instruction C.

- A. Plug one end of a long 1/8" to RCA stereo audio cable (available at electronics stores) into the input jack on the console. Plug the other end of the cable into the AUDIO OUT jack on your stereo.

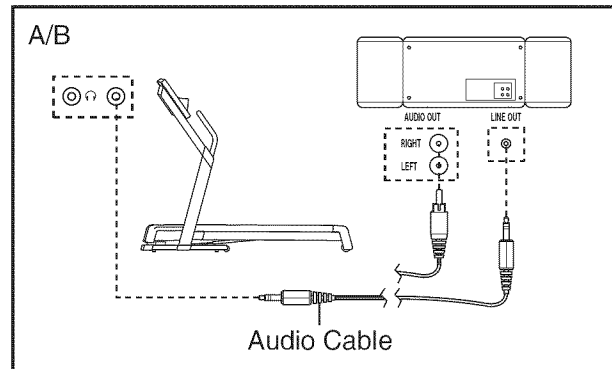

- B. See the drawing above. Plug one end of a long 1/8" to 1/8" stereo audio cable (available at electronics stores) into the input jack on the console. Plug the other end of the cable into the LINE OUT jack on your stereo. Note: While the cable is plugged into the LINE OUT jack, do not plug your headphones into the headphone jack on the console.
- C. Plug one end of a long 1/8" to 1/8" stereo audio cable (available at electronics stores) into the input jack on the console. Plug the other end of the cable into the PHONES jack on your stereo. Plug your headphones into the headphone jack on the console.

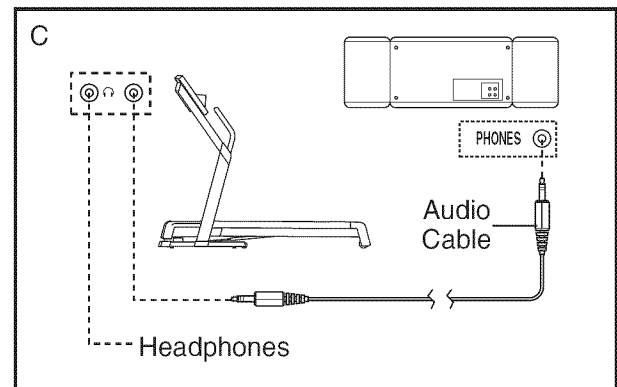

HOW TO CONNECT YOUR HOME STEREO

Note: If your stereo has an unused LINE OUT jack, see instruction A below. If the LINE OUT jack is being used, see instruction B.

- A. Plug one end of a long 1/8" to RCA stereo audio cable (available at electronics stores) into the input jack on the console. Plug the other end of the cable into the LINE OUT jack on your stereo. Note: While the cable is plugged into the LINE OUT jack, do not plug your headphones into the headphone jack on the console.

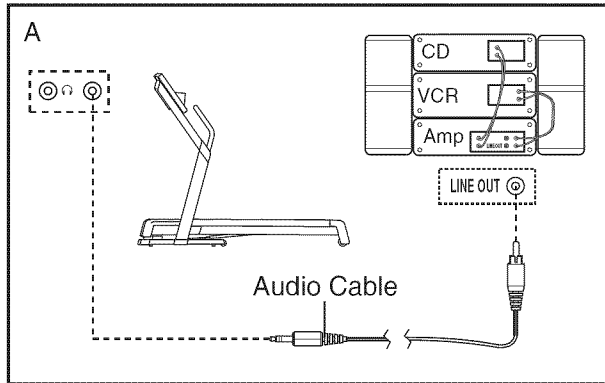

- B. Plug one end of a long 1/8" to RCA stereo audio cable (available at electronics stores) into the input jack on the console. Plug the other end of the cable into an RCA Y-adapter (available at electronics stores). Next, remove the wire that is currently plugged into the LINE OUT jack on your stereo and plug the wire into the unused side of the Y-adapter. Plug the Y-adapter into the LINE OUT jack on your stereo. Note: While the Y-adapter is plugged into the LINE OUT jack, do not plug your headphones into the headphone jack on the console.

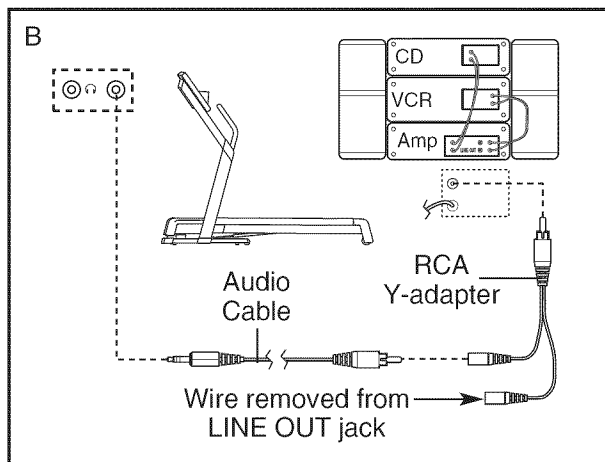

HOW TO CONNECT YOUR COMPUTER

- A. Plug one end of a long 1/8" to 1/8" stereo audio cable (available at electronics stores) into the input jack on the console. Plug the other end of the cable into the LINE OUT jack on your computer. Note: While the cable is plugged into the LINE OUT jack, do not plug your headphones into the headphone jack on the console.

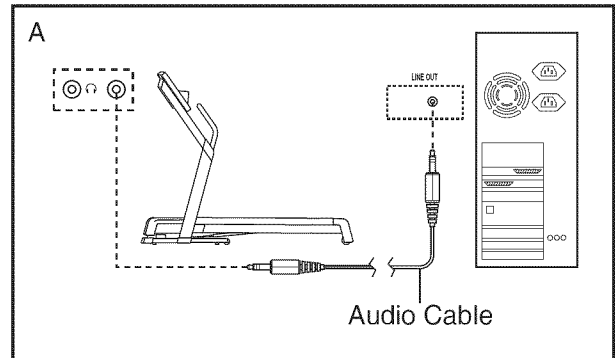

HOW TO CONNECT YOUR VCR

Note: If your VCR has an unused AUDIO OUT jack, see instruction A below. If the AUDIO OUT jack is being used, see instruction B. If you have a TV with a built-in VCR, see instruction B. If your VCR is connected to your home stereo, see **HOW TO CONNECT YOUR HOME STEREO** on page 22.

Note: To use an iFIT.com video, your VCR must also be connected to the 75 ohm antenna terminal (see **HOW TO CONNECT AN ANTENNA** on page 26).

- A. Plug one end of a long 1/8" to RCA stereo audio cable (available at electronics stores) into the input jack on the console. Plug the other end of the cable into the AUDIO OUT jack on your VCR.

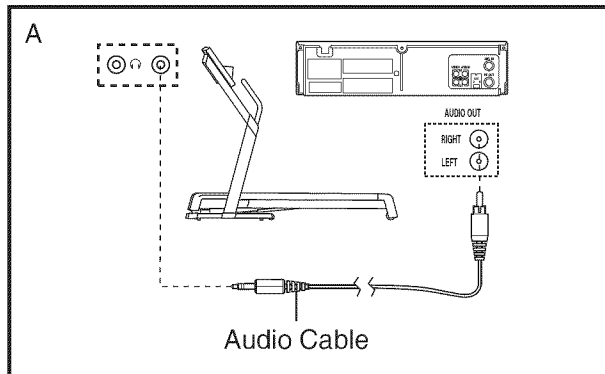

- B. Plug one end of a long 1/8" to RCA stereo audio cable (available at electronics stores) into the input jack on the console. Plug the other end of the cable into an RCA Y-adapter (available at electronics stores). Next, remove the wire that is currently plugged into the AUDIO OUT jack on your VCR and plug the wire into the unused side of the Y-adapter. Plug the Y-adapter into the AUDIO OUT jack on your VCR.

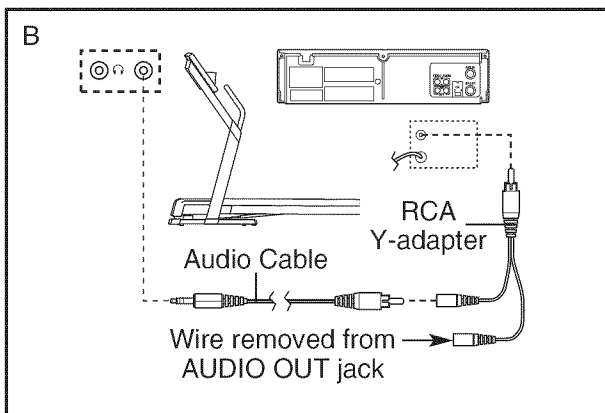

HOW TO USE AN iFIT.COM MP3, CD, OR VIDEO PROGRAM

To use an iFIT.com MP3, CD, or video program, the treadmill must be connected to your MP3 player, CD player, or VCR. See **HOW TO CONNECT THE TREADMILL TO USE iFIT.COM PROGRAMS** on pages 21 to 23. **To purchase and download iFIT.com MP3 programs, go to www.iFIT.com. To purchase iFIT.com CDs or videocassettes, call toll-free 1-888-825-2588.**

Follow the steps below to use an iFIT.com MP3, CD, or video program.

1 Insert the key into the console.

See **HOW TO TURN ON THE POWER** on page 13.

2 Identify yourself as user A, B, C, or D.

See step 2 on page 13.

3 Select the iFIT.com mode.

To select the iFIT.com mode, press the Programs button repeatedly until the words "iFIT Mode" appear on the screen.

4 Press the Play button on your MP3 player, CD player, or VCR.

Note: If you are using an iFIT.com CD, insert the CD into your CD player; if you are using an iFIT.com videocassette, insert the videocassette into your VCR.

A moment after the Play button is pressed, your personal trainer will begin guiding you through your workout. Simply follow your personal trainer's instructions. **Note:** If the time is flashing on the screen, press the Start button or the Speed increase button on the console. The treadmill will not respond to an MP3, CD, or video program while the time is flashing on the screen. **If you are not viewing the personal television while using the program, turn off the television.**

During the program, an electronic “chirping” sound will alert you when the speed and/or the incline of the treadmill is about to change. **CAUTION: Always listen for the “chirp” and be prepared for speed and/or incline changes. In some instances, the speed and/or the incline may change before your personal trainer describes the change.**

If the speed setting and/or the incline setting is too high or too low, you can manually override the setting at any time by pressing the Speed or Incline buttons on the console. However, **when the next “chirp” is heard, the speed and/or the incline will change to the next settings of the program.**

To stop the walking belt at any time, press the Stop button on the console. If the time is displayed on the screen, the time will begin to flash. To restart the program, press the Start button or the Speed increase button. After a moment, the walking belt will begin to move at 1 mph. **When the next “chirp” is heard, the speed and/or the incline will change to the next settings of the program.**

When the program is completed, the walking belt will stop. Note: To use another MP3, CD, or video program, press the Stop button or remove the key and go to step 1 on page 23.

Note: If the speed and/or the incline of the treadmill does not change when a “chirp” is heard:

- **Make sure that the time is not flashing on the screen. If the time is flashing, press the Start button or the Speed increase button on the console.**

- **Adjust the volume of your MP3 player, CD player, or VCR. If the volume is too high or too low, the console may not detect the program signals.**
- **Make sure that the audio cable is properly connected.**
- **If you are using a portable CD player and the CD skips, set the CD player on the floor or another flat surface instead of on the console.**

5 Adjust the cushioning system as desired.

See step 6 on page 14.

6 Select a display mode and follow your progress with the exercise information on the screen.

See step 7 on page 14.

7 Measure your heart rate if desired.

See step 8 on page 15.

8 Turn on the fans if desired.

See step 9 on page 15.

9 When you are finished exercising, remove the key from the console.

See step 10 on page 15.

CAUTION: Always remove iFIT.com CDs and videocassettes from your CD player and VCR and disconnect your MP3 player when you are not using them.

HOW TO USE AN iFIT.COM PROGRAM DIRECTLY FROM OUR WEB SITE

Our Web site at www.iFIT.com allows you to access programs directly from the internet. See www.iFIT.com for details.

To use a program from our Web site, the treadmill must be connected to your home computer. See HOW TO CONNECT YOUR COMPUTER on page 22. In addition, you must have an internet connection and an internet service provider. A list of specific system requirements is found on our Web site.

Follow the steps below to use a program from our Web site.

1 Insert the key into the console.

See HOW TO TURN ON THE POWER on page 13.

2 Identify yourself as user A, B, C, or D.

See step 2 on page 13.

3 Select the iFIT.com mode.

See step 3 on page 23.

4 Go to your computer and start an internet connection.

5 Start your web browser, if necessary, and go to our Web site at www.iFIT.com.

6 Follow the desired links on our Web site to select a program.

Read and follow the on-line instructions for using a program.

7 Follow the on-line instructions to start the program.

When you start the program, an on-screen countdown will begin.

8 Return to the treadmill and stand on the foot rails. Find the clip attached to the key and slide the clip onto the waistband of your clothes.

When the on-screen countdown ends, the program will begin and the walking belt will begin to move. Hold the handrails, step onto the walking belt, and begin walking. **If you are not viewing the personal television while using the program, turn**

off the television. During the program, an electronic “chirping” sound will alert you when the speed and/or the incline of the treadmill is about to change. **CAUTION: Always listen for the “chirp” and be prepared for speed and/or incline changes.**

If the speed setting or the incline setting is too high or too low, you can manually override the settings at any time by pressing the Speed or Incline buttons on the console. **However, when the next “chirp” is heard, the speed and/or the incline will change to the next settings of the program.**

To stop the walking belt at any time, press the Stop button on the console. If the time is displayed on the screen, the time will begin to flash. To restart the program, press the Start button or the Speed increase button. After a moment, the walking belt will begin to move at 1 mph. **When the next “chirp” is heard, the speed and/or the incline will change to the next settings of the program.**

When the program is completed, the walking belt will stop. Note: To use another program, press the Stop button and go to step 5.

Note: If the speed and/or the incline of the treadmill does not change when a “chirp” is heard, make sure that the letters “iFIT” appear on the screen and that the time is not flashing on the screen. In addition, make sure that the audio cable is properly connected.

9 Adjust the cushioning system as desired.

See step 6 on page 14.

10 Select a display mode and follow your progress with the exercise information on the screen.

See step 7 on page 14.

11 Measure your heart rate if desired.

See step 8 on page 15.

12 Turn on the fans if desired.

See step 9 on page 15.

13 When you are finished exercising, remove the key from the console.

See step 10 on page 15.

HOW TO OPERATE THE PERSONAL TELEVISION

DIAGRAM OF THE TELEVISION CONTROLS

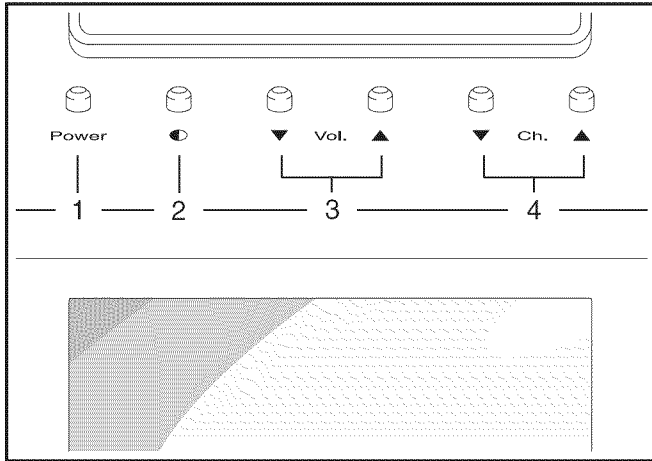

1. TV Power button
2. Text Background button
3. Volume buttons
4. Channel buttons

HOW TO CONNECT AN ANTENNA

Indoor Antenna

1. Place the VHF antenna in the desired location. Connect the 300 ohm flat wire to the screws on the 300 ohm to 75 ohm adapter.

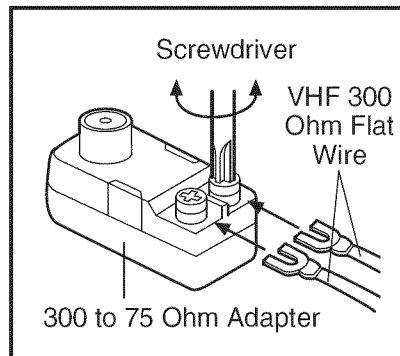

2. Connect the 300 ohm to 75 ohm adapter to the 75 ohm antenna terminal on the treadmill. (See assembly drawing 6 on page 10 to find the location of the terminal.)

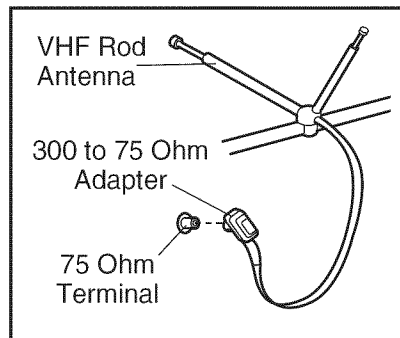

Outdoor Antenna

Outdoor antennas are subject to weathering that can reduce signal quality. Inspect the antenna and lead-in wiring before connecting the antenna. Any service center can explain the various outdoor antennas available.

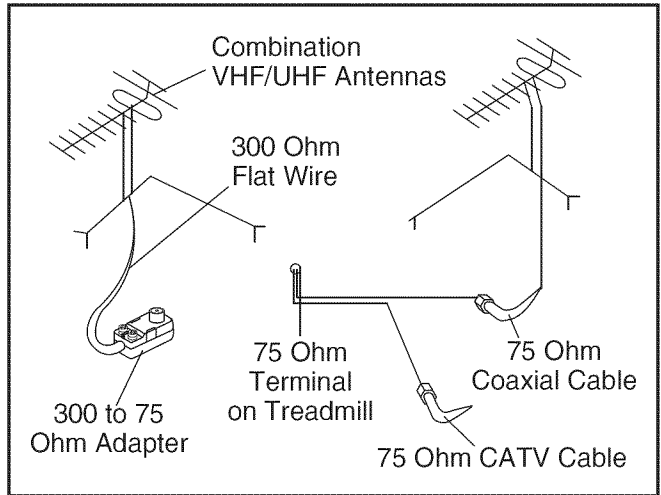

300 Ohm Flat Wire

1. See the drawing above. Connect the 300 ohm flat wire to the 300 ohm to 75 ohm adapter.
2. Press the end of the 300 ohm to 75 ohm adapter into the 75 ohm antenna terminal on the treadmill. (See assembly drawing 6 on page 10 to find the location of the terminal.)

75 Ohm Coaxial Cable

See the drawing above. Connect the 75 ohm coaxial cable directly to the 75 ohm antenna terminal on the treadmill. (See assembly drawing 6 on page 10 to find the location of the terminal.)

HOW TO CONNECT A CATV CABLE

1. Remove the VHF 300 to 75 ohm adapter or the VHF cable from the antenna terminal on the treadmill. (See assembly drawing 6 on page 10 to find the location of the terminal.)
2. Connect the CATV cable (75 ohm coaxial cable) to the 75 ohm antenna terminal on the treadmill.

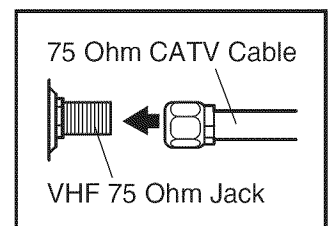

HOW TO CONNECT A VCR

Follow the steps below to connect your VCR (not included) to the treadmill. A CATV cable (75 ohm coaxial cable) is required.

1. Connect one end of the CATV cable to the video output jack on your VCR.
2. Plug in the power cord of your VCR. See your VCR user's manual for proper grounding instructions.
3. Connect the CATV cable to the 75 ohm antenna terminal on the treadmill. (See assembly drawing 6 on page 10 to find the location of the terminal.)

To operate the television with your VCR, **make sure that channel 3 or 4 is selected.**

BASIC TELEVISION OPERATION

1 Insert the key into the console.

See HOW TO TURN ON THE POWER on page 13.

2 Press the Power button to turn on the television.

When the television is turned on, the screen will show channel 3 or 4 or the last saved channel (see step 3 below).

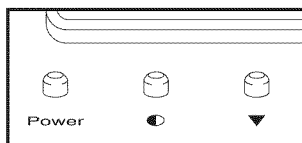

3 Press the Channel buttons to select the desired channel.

When either Channel button is pressed, the selected channel number will appear on the screen for a few seconds. For a channel to be automatically selected each time the television is turned on, press the Save button while the channel is selected. Note: The television is equipped with a channel memorizing function that allows you to go directly from the current channel to the next channel set into memory. Before channels can be selected in

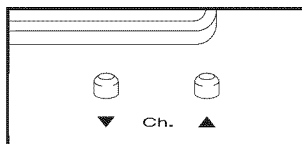

this way, they must be set into the television's memory. See HOW TO USE THE INFORMATION MODE on page 28.

Note: Channels can also be selected with the remote control. See HOW TO USE THE REMOTE CONTROL on page 28.

4 Press the Volume buttons to adjust the volume.

When either Volume button is pressed, the volume level indicator will appear on the screen for a few seconds. There are 20 volume levels. Note: To use earphones or headphones (not included), plug them into the headphone jack on the console.

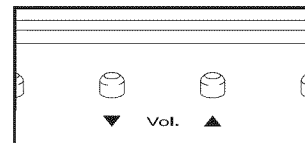

Note: The volume can also be controlled with the remote control. See HOW TO USE THE REMOTE CONTROL on page 28. When the iFIT.com mode is selected, the Volume buttons will control the volume of the iFIT.com program. To control the volume of the television during an iFIT.com program, press the Volume increase and decrease buttons simultaneously so that the words "Audio Source: TV" appear on the screen.

5 Press the Text Background button to turn on the text background if desired.

If the exercise information on the screen is difficult to read due to the background color, press the Text Background button. A colored box will appear behind the text for increased readability. Note: When the television is turned off, pressing the Text Background button will change the screen color from blue to black.

6 When you are finished using the television, press the Power button.

When the television is turned off, the screen will display a blue or black background.

7 When you are finished using the treadmill, remove the key from the console.

See step 10 on page 15.

HOW TO USE THE REMOTE CONTROL

The convenient remote control can be used to control the speed and incline of the treadmill and the volume and channel of the personal television. The buttons on the remote control function in the same way as the corresponding buttons on the console. When pressing buttons, point the remote control toward the sensor on the pulse bar. Make sure that the sensor is not exposed to direct sunlight. **CAUTION: Keep the remote control with you at all times while you are using the treadmill. Injury can result if another person changes the speed or the incline of the treadmill while you are using the treadmill.**

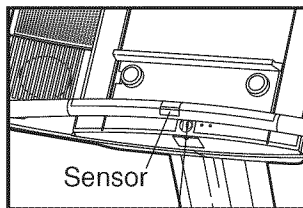
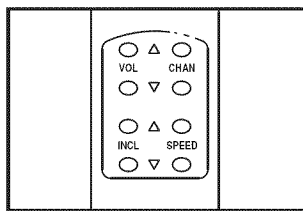

The words "Demo Off" or "Demo On" will also appear on the screen. The treadmill features a demo mode that is intended to be used only when a treadmill is displayed in a store. When the demo mode is turned on, the power cord can be plugged in, the key can be removed from the console, and the indicators on the console will automatically light in a preset sequence, although the buttons on the console will not operate. Press the Speed decrease button to turn on or turn off the demo mode.

2 Press the Stop button again, select a cable connection or an antenna connection, and scan and memorize channels.

When the Stop button is pressed, the word "Cable" or the word "Air" will appear on the screen. If you have connected a CATV cable to the treadmill, the "Cable" setting should be selected; if you have connected an antenna, the "Air" setting should be selected. Press the Power button to change the setting, if necessary.

The word "Scan" will also appear on the screen. To scan all of the channels available in your area, press the Channel increase button. The television will begin scanning the channels. When no broadcast signal is detected on a channel, the channel will be skipped. When a signal is detected, the channel will be stored in memory, a tone will sound, and the next channel will be selected. This process will be repeated until the highest channel is reached. A series of tones will then sound.

3 Press the Stop button again and add or delete channels.

After all valid channels available in your area have been set into memory, you can manually add channels or delete unwanted channels.

To add a channel, first press the Channel buttons until the desired channel number and the word "ADD" appear on the screen. Press the Power button to add the channel. **To delete an unwanted channel**, first press the Channel buttons until the unwanted channel number and the word "Remove" appear. Press the Power button to delete the channel. Continue this process until you have added all desired channels and deleted all unwanted channels.

HOW TO USE THE INFORMATION MODE

The console features an information mode that keeps track of the total number of hours that the treadmill has been used and the total number of miles that the walking belt has moved. The information mode also allows you to select miles or kilometers as the unit of measurement for the console, to turn on and turn off the demo mode, to set channels into the television's memory, and to reset all programs to the original settings.

Follow the steps below to use the information mode.

1 Hold down the Stop button while inserting the key into the console.

A moment after the key is inserted, the lower right corner of the screen will show the total number of miles (or kilometers) that the walking belt has moved and the total number of hours that the treadmill has been used.

In addition, the word "English" (for miles) or "Metric" (for kilometers) will appear on the screen. Press the Speed increase button to change the unit of measurement, if desired.

4 Press the Stop button again and restore the console to the factory settings if desired.

When the Stop button is pressed, the words “Restore to Factory Settings” will appear on the screen. If you wish to erase all settings that users A, B, C, and D have saved, press the Start button. The words “Are You Sure?” will then appear on the screen. To confirm that you wish to erase the

settings, press the Save button. The console will then be restored to the factory settings.

5 Remove the key from the console to exit the information mode.

When the key is removed, the information mode will be exited.

HOW TO MOVE THE TREADMILL

1. Unplug the power cord.
2. Hold the treadmill with your hands in the location shown by the arrow at the right. **CAUTION: To decrease the possibility of injury, bend your legs and keep your back straight. As you raise the treadmill, make sure to lift with your legs rather than your back.**
3. Push the the treadmill to the desired location. **To reduce the risk of injury, use extreme caution while moving the treadmill.**
4. Carefully lower the treadmill until it is resting on the floor.

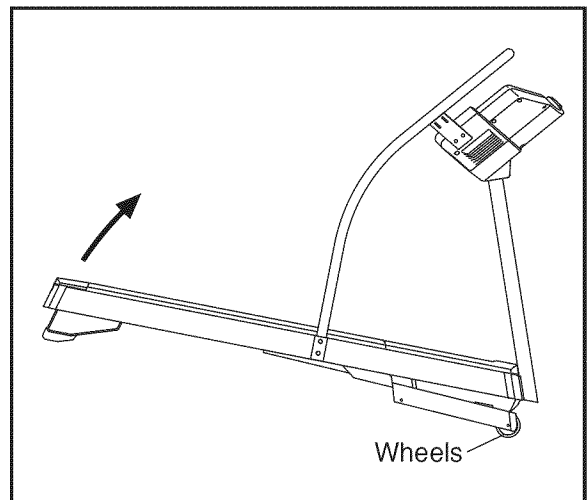

TROUBLESHOOTING

Most treadmill problems can be solved by following the steps below. Find the symptom that applies, and follow the steps listed. If further assistance is needed, please call our Customer Service Department toll-free at 1-888-825-2588, Monday through Friday, 6 a.m. until 6 p.m. Mountain Time (excluding holidays).

PROBLEM: The power does not turn on

SOLUTION: a. Make sure that the power cord is plugged into a surge suppressor, and that the surge suppressor is plugged into a properly grounded outlet (see page 11). Use only a single-outlet surge suppressor that meets all of the specifications described on page 11. Important: The treadmill is not compatible with GFCI-equipped outlets.

b. After the power cord has been plugged in, make sure that the key is fully inserted into the console.

c. Check the reset/off circuit breaker located on the treadmill frame near the power cord. If the switch protrudes as shown, the circuit breaker has tripped. To reset the circuit breaker, wait for five minutes and then press the switch to the reset position.

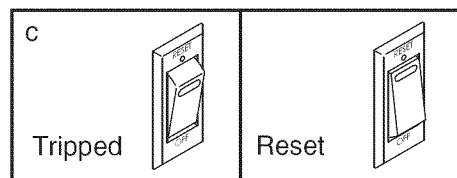

PROBLEM: The power turns off during use

SOLUTION: a. Check the reset/off circuit breaker (see the drawing above). If the circuit breaker has tripped, wait for five minutes and then press the switch to the reset position.

b. Make sure that the power cord is plugged in. If the power cord is plugged in, unplug it, wait for five minutes, and then plug it back in.

c. Remove the key from the console. Reinsert the key fully into the console.

d. If the treadmill still will not run, please call our Customer Service Department, toll-free.

PROBLEM: The displays of the console do not function properly

SOLUTION: a. Remove the key from the console and **UNPLUG THE POWER CORD**. Remove the two indicated Screws (4) from the front of the treadmill. Insert the tip of a slotted screwdriver between the Hood (58) and the Frame (28) and against the tab on the bottom of the Hood in the location shown. Carefully lift the Hood while pressing on the tab with the screwdriver. Repeat on the other side. Remove the Hood.

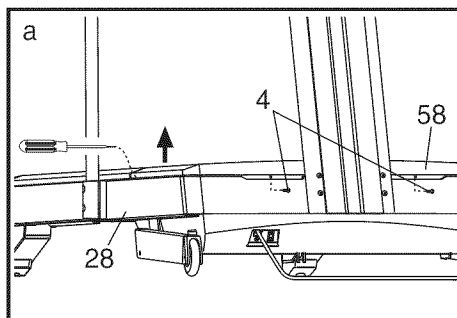

Locate the Reed Switch (38) and the Magnet (40) on the left side of the Pulley (131). Turn the Pulley until the Magnet is aligned with the Reed Switch. **Make sure that the gap between the Magnet and the Reed Switch is about 1/8"**. If necessary, use a slotted screwdriver to move the Reed Switch slightly. Then, reattach the Hood (58). Run the treadmill for a few minutes to check for a correct speed reading.

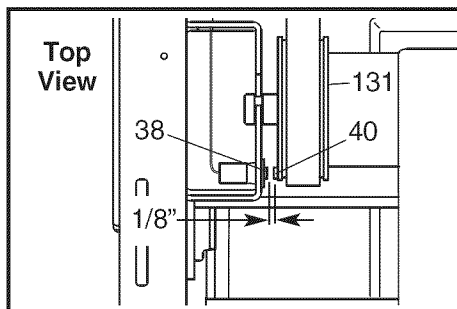

PROBLEM: The walking belt slows when walked on

SOLUTION: a. Use only a single-outlet surge suppressor that meets all of the specifications described on page 11.

b. If the walking belt is overtightened, treadmill performance may decrease and the walking belt may become damaged. Remove the key and **UNPLUG THE POWER CORD**. Using the allen wrench, turn both rear roller adjustment bolts counterclockwise, 1/4 of a turn. When the walking belt is properly tightened, you should be able to lift each side of the walking belt 3 to 4 inches off the walking platform. Be careful to keep the walking belt centered. Plug in the power cord, insert the key, and run the treadmill for a few minutes. Repeat until the walking belt is properly tightened.

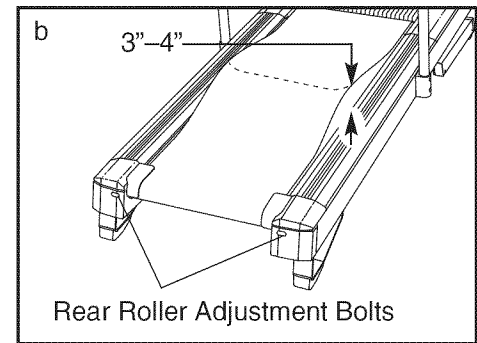

c. If the walking belt still slows when walked on, please call our Customer Service Department, toll-free.

PROBLEM: The walking belt is off-center or slips when walked on

SOLUTION: a. If the walking belt is off-center, remove the key and **UNPLUG THE POWER CORD**. **If the walking belt has shifted to the left**, use the allen wrench to turn the left rear roller bolt clockwise 1/2 of a turn; **if the walking belt has shifted to the right**, turn the left rear roller bolt counterclockwise 1/2 of a turn. Be careful not to overtighten the walking belt. Plug in the power cord, insert the key, and run the treadmill for a few minutes. Repeat until the walking belt is centered.

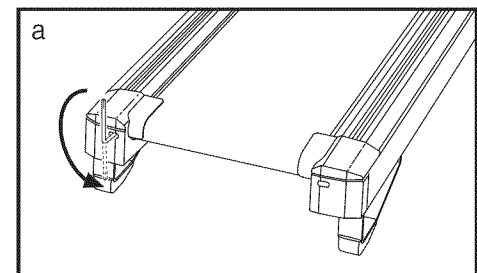

b. If the walking belt slips when walked on, first remove the key and **UNPLUG THE POWER CORD**. Using the allen wrench, turn both rear roller bolts clockwise, 1/4 of a turn. When the walking belt is correctly tightened, you should be able to lift each side of the walking belt 3 to 4 inches off the walking platform. Be careful to keep the walking belt centered. Plug in the power cord, insert the key, and carefully walk on the treadmill for a few minutes. Repeat until the walking belt is properly tightened.

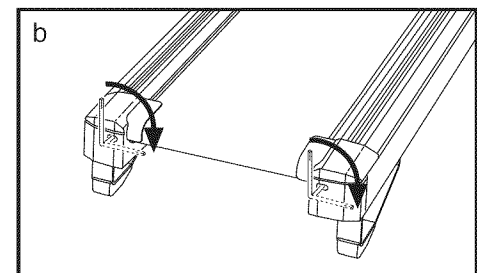

PROBLEM: Television reception is poor

SOLUTION: a. For the television to operate properly, good reception is necessary. If you are using an antenna, make sure that it is properly connected and adjusted for optimal reception. (See HOW TO CONNECT AN ANTENNA on page 26.)

b. Check for the problems listed below and follow the applicable instructions.

- Ignition (black spots or horizontal streaks that appear on a picture that flutters or drifts)—Usually this is caused by interference from automobile ignition systems, neon lamps, electric drifts, or other electric appliances. Try changing the position of the treadmill or other electric appliances to correct the problem.
- Ghosts—Ghosts are caused by the television signal following two paths—one is the direct path and the other is reflected from tall buildings, hills, or other objects. Change the direction or position of the antenna to improve reception.

- Blue Screen—If the treadmill is located in the fringe area of a television station where the signal is weak, the picture may be of poor quality or a blue screen may appear. If the signal is weak, it may be necessary to install an external antenna to improve the picture.

Note: If one of these symptoms appears when the cable from a CATV company is connected, the symptom may be caused by the local company broadcast.

PROBLEM: The remote control does not function properly

SOLUTION: a. When pressing buttons on the remote control, point the remote control toward the sensor on the pulse bar. Make sure that the sensor is not exposed to direct sunlight.

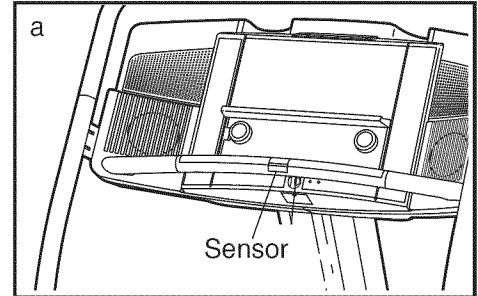

b. Make sure that the batteries in the remote control are properly installed. If the batteries are properly installed, replace the batteries. (See assembly step 7 on page 10.)

CONDITIONING GUIDELINES

⚠️ WARNING: Before beginning this or any exercise program, consult your physician. This is especially important for individuals over the age of 35 or individuals with pre-existing health problems.

The pulse sensor is not a medical device. Various factors, including your movement, may affect the accuracy of heart rate readings. The sensor is intended only as an exercise aid in determining heart rate trends in general.

The following guidelines will help you to plan your exercise program. For more detailed exercise information, obtain a reputable book or consult your physician.

EXERCISE INTENSITY

Whether your goal is to burn fat or to strengthen your cardiovascular system, the key to achieving the desired results is to exercise with the proper intensity. The proper intensity level can be found by using your heart rate as a guide. The chart below shows recommended heart rates for fat burning and aerobic exercise.

AEROBIC	165	155	145	140	130	125	115
MAX FAT BURN	145	138	130	125	118	110	103
FAT BURN	125	120	115	110	105	95	90
Age	20	30	40	50	60	70	80

To find the proper heart rate for you, first find your age near the bottom of the chart (ages are rounded off to the nearest ten years). Next, find the three numbers above your age. The three numbers define your “training zone.” The lower two numbers are recommended heart rates for fat burning; the higher number is the recommended heart rate for aerobic exercise.

To measure your heart rate during exercise, use the pulse sensor.

Fat Burning

To burn fat effectively, you must exercise at a relatively low intensity level for a sustained period of time. During the first few minutes of exercise, your body uses easily accessible *carbohydrate calories* for en-

ergy. Only after the first few minutes does your body begin to use stored *fat calories* for energy. If your goal is to burn fat, adjust the speed and incline of the treadmill until your heart rate is near the lowest number in your training zone.

For maximum fat burning, adjust the speed and incline of the treadmill until your heart rate is near the middle number in your training zone.

Aerobic Exercise

If your goal is to strengthen your cardiovascular system, your exercise must be “aerobic.” Aerobic exercise is activity that requires large amounts of oxygen for prolonged periods of time. This increases the demand on the heart to pump blood to the muscles, and on the lungs to oxygenate the blood. For aerobic exercise, adjust the speed and incline of the treadmill until your heart rate is near the highest number in your training zone.

WORKOUT GUIDELINES

Each workout should include the following three parts:

A Warm-up—Start each workout with 5 to 10 minutes of stretching and light exercise. A proper warm-up increases your body temperature, heart rate and circulation in preparation for exercise.

Training Zone Exercise—After warming up, increase the intensity of your exercise until your pulse is in your training zone for 20 to 60 minutes. (During the first few weeks of your exercise program, do not keep your pulse in your training zone for longer than 20 minutes.) Breathe regularly and deeply as you exercise—never hold your breath.

A Cool-down—Finish each workout with 5 to 10 minutes of stretching to cool down. This will increase the flexibility of your muscles and will help prevent post-exercise problems.

EXERCISE FREQUENCY

To maintain or improve your condition, complete three workouts each week, with at least one day of rest between workouts. After a few months, you may complete up to five workouts each week if desired. The key to success is to make exercise a regular and enjoyable part of your everyday life.

PART LIST—Model No. NTL24950

R1204E

To locate the parts listed below, see the EXPLODED DRAWING attached in the center of this manual.

Key No.	Qty.	Description	Key No.	Qty.	Description
1	2	Foot Rail Cover	51	2	Motor Bolt
2	1	Left Foot Rail	52	1	Frame Cover
3	8	Foot Rail Screw	53	1	Ground Wire
4	60	1/2" Screw	54	1	Reset/Off Circuit Breaker
5	1	Left Foot Rail Endcap	55	1	Power Cord Plate
6	2	Isolator Top Cap	56	1	Power Cord Grommet
7	4	Spring Nut	57	1	Power Cord
8	2	Isolator Spring	58	1	Hood
9	2	Isolator	59	2	Hood Clip
10	2	Isolator Bottom Cap	60	1	Transformer
11	2	Spring Pad Screw	61	1	Controller
12	2	Leaf Spring	62	2	Cotter Pin
13	2	Spring Pad	63	1	Upper Clevis Pin
14	5	Lock Nut	64	1	Lower Clevis Pin
15	2	Leaf Spring Plate	65	1	Incline Motor
16	2	Leaf Spring Spacer	66	2	Front Wheel
17	4	Leaf Spring Washer	67	2	Wheel Housing
18	4	Leaf Spring Bolt	68	2	Wheel Nut
19	2	Rear Endcap Screw	69	1	Lift Frame
20	2	Rear Roller Adjustment Bolt	70	2	Wheel Bolt
21	2	Rear Roller Washer	71	1	Circuit Board
22	1	Left Rear Endcap	72	4	Plastic Stand-off
23	4	Rear Foot Screw	73	2	Lift Leg Spacer
24	2	Rear Foot	74	2	Lift Leg Bolt
25	1	Rear Roller	75	1	Cushion Sensor
26	2	Rear Platform Bolt	76	1	Cushion Magnet
27	2	Gear Rack	77	2	Lift Leg Endcap
28	1	Frame	78	1	Circuit Board Bracket
29	1	Walking Belt	79	1	Cushion Motor Bolt
30	1	Walking Platform	80	1	Cushion Motor
31	4	Frame Bolt	81	1	Cushion Adj. Rod
32	2	Handrail Bracket	82	2	Cushion Adj. Gear
33	2	Belt Guide	83	2	Cushion Adj. Wheel
34	2	Isolator Bolt	84	2	Cushion Adj. Pin
35	2	Front Platform Bolt	85	2	Cushion Rod Clip
36	1	Right Foot Rail Endcap	86	1	Right Handrail
37	1	Belly Pan	87	2	Platform Nut
38	1	Reed Switch	88	1	Right Rear Endcap
39	1	Reed Switch Clip	89	1	Left Handrail
40	1	Magnet	90	4	Handrail Bolt
41	2	Idler Arm Washer	91	4	3/4" Tek Screw
42	4	Idler Arm Nut/Incline Nut	92	1	Console Ground Wire
43	1	Idler Arm Pulley	93	1	Upper Handrail
44	1	Pulley Bolt	94	1	Console Back
45	1	Idler Arm Pivot Bolt	95	45	3/4" Screw
46	1	Idler Arm Spacer	96	4	Small Screw
47	1	Idler Arm	97	1	Ground Screw
48	1	Idler Arm Spring	98	1	Console Base
49	1	Motor Belt	99	1	Tray Insert
50	1	Drive Motor	100	2	Fan

Key No.	Qty.	Description	Key No.	Qty.	Description
101	1	TV Console	125	1	Left Speaker
102	2	Control Knob	126	1	Right Speaker
103	1	Pulse Bar	127	1	Belly Pan Insert
104	1	15" Wire Harness	128	1	Filter Wire
105	1	Key/Clip	129	1	Controller Wire
106	1	Short Panel	130	1	Console
107	1	Console Frame	131	1	Front Roller
108	1	Wire Harness	132	1	Static Decal
109	1	TV Cable	133	2	Caution Decal
110	4	Console Bolt	134	1	Remote Control
111	1	Upright	135	1	5/32" Allen Wrench
112	1	Long Panel	136	1	Allen Wrench
113	4	Upright Bolt	137	1	Book Holder
114	4	Star Washer	138	2	Front Isolator
115	1	Upright Plate	139	6	Panel Screw
116	4	Washer	140	3	Panel Bracket
117	1	iFIT Cable	#	1	6" Blue Wire, 2F
118	10	Plastic Tie	#	1	4" Blue Wire, M/F
119	1	Releasable Tie	#	1	8" Green Wire, F/Ring
120	5	Tie Holder	#	1	User's Manual
121	1	Access Door			
122	1	Hood Cover			
123	4	Washer			
124	1	Right Foot Rail			

*Includes all parts shown in box

#These parts are not illustrated

Specifications are subject to change without notice.

ORDERING REPLACEMENT PARTS

To order replacement parts, call our Customer Service Department toll-free at 1-888-825-2588, Monday through Friday, 6 a.m. until 6 p.m. Mountain Time (excluding holidays). When ordering parts, please be prepared to give the following information:

- the MODEL NUMBER OF THE PRODUCT (NTL24950)
- the NAME OF THE PRODUCT (NordicTrack® VIEW POINT treadmill)
- the SERIAL NUMBER OF THE PRODUCT (see the front cover of this manual)
- the KEY NUMBER AND DESCRIPTION OF THE PART(S) (see the PART LIST on pages 34 and 35 and the EXPLODED DRAWING attached in the center of this manual)

LIMITED WARRANTY

WHAT IS COVERED—The entire NordicTrack® VIEW POINT treadmill (“Product”) is warranted to be free of all defects in material and workmanship.

WHO IS COVERED—The original purchaser or any person receiving the Product as a gift from the original purchaser.

HOW LONG IS IT COVERED—ICON Health & Fitness, Inc. (“ICON”), warrants the drive motor for life. Parts and labor are warranted for one year from the date of purchase.

WHAT WE DO TO CORRECT COVERED DEFECTS—We will ship to you, without charge, any replacement part or component, providing the repairs are authorized by ICON first and are performed by an ICON trained and authorized service provider, or, at our option, we will replace the Product.

WHAT IS NOT COVERED—Any failures or damage caused by unauthorized service, misuse, accident, negligence, improper assembly or installation, alterations, modifications without our written authorization or by failure on your part to use, operate, and maintain as set out in your User’s Manual (“Manual”). This warranty does not extend to products used for commercial or rental purposes.

WHAT YOU MUST DO—Always retain proof of purchase, such as your bill of sale; store, operate, and maintain the Product as specified in the Manual; notify our Customer Service Department of any defect within 10 days after discovery of the defect; as instructed, return any defected part for replacement or, if necessary, the entire product, for repair.

USER’S MANUAL—It is VERY IMPORTANT THAT YOU READ THE MANUAL before operating the Product. Remember to do the periodic maintenance requirements specified in the Manual to assure proper operation and your continued satisfaction.

HOW TO GET PARTS AND SERVICE—Simply call our Customer Service Department at 1-888-825-2588 and tell them your name and address and the serial number of your Product. They will tell you how to get a part replaced, or if necessary, arrange for service where your Product is located or advise you how to ship the Product for service. Before shipping, always obtain a Return Authorization Number (RA No.) from our Customer Service Department; securely pack your Product (save the original shipping carton if possible); put the RA No. on the outside of the carton and insure the product. Include a letter explaining the product or problem and a copy of your proof of purchase if you believe the service is covered by warranty.

ICON is not responsible or liable for indirect, special or consequential damages arising out of or in connection with the use or performance of the product or damages with respect to any economic loss, loss of property, loss of revenues or profits, loss of enjoyment or use, costs of removal, installation or other consequential damages of whatsoever nature. Some states do not allow the exclusion or limitation of incidental or consequential damages. Accordingly, the above limitation may not apply to you.

The warranty extended hereunder is in lieu of any and all other warranties and any implied warranties of merchantability or fitness for a particular purpose is limited in its scope and duration to the terms set forth herein. Some states do not allow limitations on how long an implied warranty lasts. Accordingly, the above limitation may not apply to you.

No one is authorized to change, modify or extend the terms of this limited warranty.

This warranty gives you specific legal rights and you may have other rights which vary from state to state.

ICON HEALTH & FITNESS, INC., 1500 S. 1000 W., LOGAN, UT 84321-9813