

PRO-FORM[®]

CROSSWALK 380

Model No. 831.24803.1

Serial No. _____

Write the serial number in the space above for future reference.

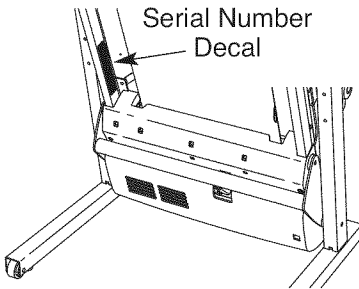

- Assembly
- Operation
- Maintenance
- Part List and Drawing

Sears, Roebuck and Co.,
Hoffman Estates, IL 60179

CAUTION

Read all precautions and instructions in this manual before using this equipment. Save this manual for future reference.

TREADMILL EXERCISER

User's Manual

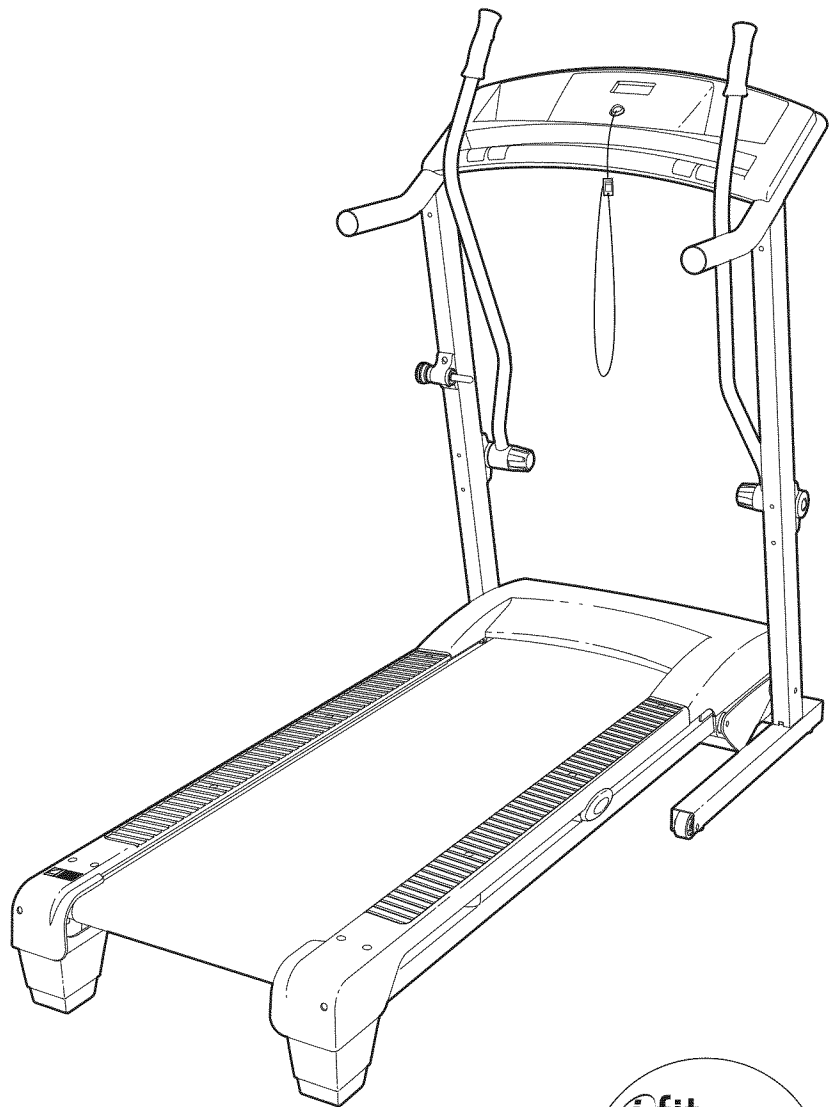
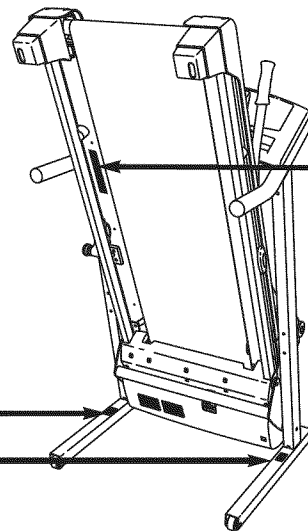

TABLE OF CONTENTS





WARNING DECAL PLACEMENT	2
IMPORTANT PRECAUTIONS	3
BEFORE YOU BEGIN	5
ASSEMBLY	6
OPERATION AND ADJUSTMENT	14
HOW TO FOLD AND MOVE THE TREADMILL	20
TROUBLESHOOTING	22
EXERCISE GUIDELINES	25
PART LIST	26
EXPLODED DRAWING	28
ORDERING REPLACEMENT PARTS	Back Cover
90 DAY FULL WARRANTY	Back Cover

WARNING DECAL PLACEMENT

This drawing shows the locations of the warning decals. **If a decal is missing or illegible, call 1-888-533-1333 and request a free replacement decal. Apply the decal in the location shown.** Note: The decals may not be shown at actual size.



⚠ WARNING:
Protect yourself and others from risk of serious injury. Read the user's manual and :

-  •Stand only on the side rails when starting or stopping treadmill.
- Change speed in small increments.
- Hold handrails to prevent falling, and always wear the safety clip while operating treadmill.
- Stop if you feel faint, dizzy, or short of breath.
- Fully engage storage latch before treadmill is moved or stored.
- Reduce incline to its lowest level before folding treadmill into storage position.
-  •Never allow children on or around treadmill.
- Remove key when not in use.
-  •Keep clothing, fingers, and hair away from moving belt.
- Never try to adjust or fix the belt while it is moving.
-  •Always wear athletic shoes while operating treadmill.

IMPORTANT PRECAUTIONS

▲ WARNING: To reduce the risk of serious injury, read all important precautions and instructions in this manual and all warnings on your treadmill before using your treadmill. Sears assumes no responsibility for personal injury or property damage sustained by or through the use of this product.

1. Before beginning any exercise program, consult your physician. This is especially important for persons over age 35 or persons with pre-existing health problems.
2. It is the responsibility of the owner to ensure that all users of this treadmill are adequately informed of all warnings and precautions.
3. Use the treadmill only as described.
4. Place the treadmill on a level surface, with at least 8 ft. (2.4 m) of clearance behind it and 2 ft. (0.6 m) on each side. Do not place the treadmill on any surface that blocks air openings. To protect the floor or carpet from damage, place a mat under the treadmill.
5. Keep the treadmill indoors, away from moisture and dust. Do not put the treadmill in a garage or covered patio, or near water.
6. Do not operate the treadmill where aerosol products are used or where oxygen is being administered.
7. Keep children under age 12 and pets away from the treadmill at all times.
8. The treadmill should not be used by persons weighing more than 250 lbs. (113 kg).
9. Never allow more than one person on the treadmill at a time.
10. Wear appropriate exercise clothes when using the treadmill. Do not wear loose clothes that could become caught in the treadmill. Athletic support clothes are recommended for both men and women. *Always wear athletic shoes; never use the treadmill with bare feet, wearing only stockings, or in sandals.*
11. When connecting the power cord (see page 14), plug the power cord into a surge suppressor (not included) and plug the surge suppressor into a grounded circuit capable of carrying 15 or more amps. No other appliance should be on the same circuit. Do not use an extension cord.
12. Use only a single-outlet surge suppressor that meets all of the specifications described on page 14. To purchase a surge suppressor, see your local Sears store or call the telephone number on the back cover of this manual and order part number 146148, or see your local electronics store.
13. Failure to use a properly functioning surge suppressor could result in damage to the control system of the treadmill. If the control system is damaged, the walking belt may slow, accelerate, or stop unexpectedly, which may result in a fall and serious injury.
14. Keep the power cord and the surge suppressor away from heated surfaces.
15. Never move the walking belt while the power is turned off. Do not operate the treadmill if the power cord or plug is damaged, or if the treadmill is not working properly. (See TROUBLESHOOTING on page 22 if the treadmill is not working properly.)
16. Read, understand, and test the emergency stop procedure before using the treadmill (see HOW TO TURN ON THE POWER on page 16).
17. Never start the treadmill while you are standing on the walking belt. Always hold the handrails while using the treadmill.
18. The pulse sensor is not a medical device. Various factors, including your movement, may affect the accuracy of heart rate readings. The pulse sensor is intended only as an exercise aid in determining heart rate trends in general.

19. The treadmill is capable of high speeds. Adjust the speed in small increments to avoid sudden jumps in speed.
20. Never leave the treadmill unattended while it is running. Always remove the key, unplug the power cord, and switch the reset/off circuit breaker to the off position when the treadmill is not in use. (See the drawing on page 5 for the location of the circuit breaker.)
21. Do not attempt to raise, lower, or move the treadmill until it is properly assembled. (See ASSEMBLY on page 6 and HOW TO FOLD AND MOVE THE TREADMILL on page 20.) You must be able to safely lift 45 lbs. (20 kg) to raise, lower, or move the treadmill.
22. When folding or moving the treadmill, make sure that the storage latch is holding the frame securely in the storage position.
23. Do not change the incline of the treadmill by placing objects under the treadmill.
24. Inspect and properly tighten all parts of the treadmill regularly.
25. Never drop or insert any object into any opening on the treadmill.
26. This treadmill is intended for in-home use only. Do not use this treadmill in a commercial, rental, or institutional setting.
27. **DANGER:** Always unplug the power cord immediately after use, before cleaning the treadmill, and before performing the maintenance and adjustment procedures described in this manual. Never remove the motor hood unless instructed to do so by an authorized service representative. Servicing other than the procedures in this manual should be performed by an authorized service representative only.

SAVE THESE INSTRUCTIONS

BEFORE YOU BEGIN

Thank you for selecting the new PROFORM® CROSSWALK 380 treadmill. The CROSSWALK 380 treadmill offers a selection of features designed to make your workouts at home more effective and enjoyable. And when you're not exercising, the treadmill can be folded up, requiring less than half the floor space of other treadmills.

For your benefit, read this manual carefully before using the treadmill. If you have questions after read-



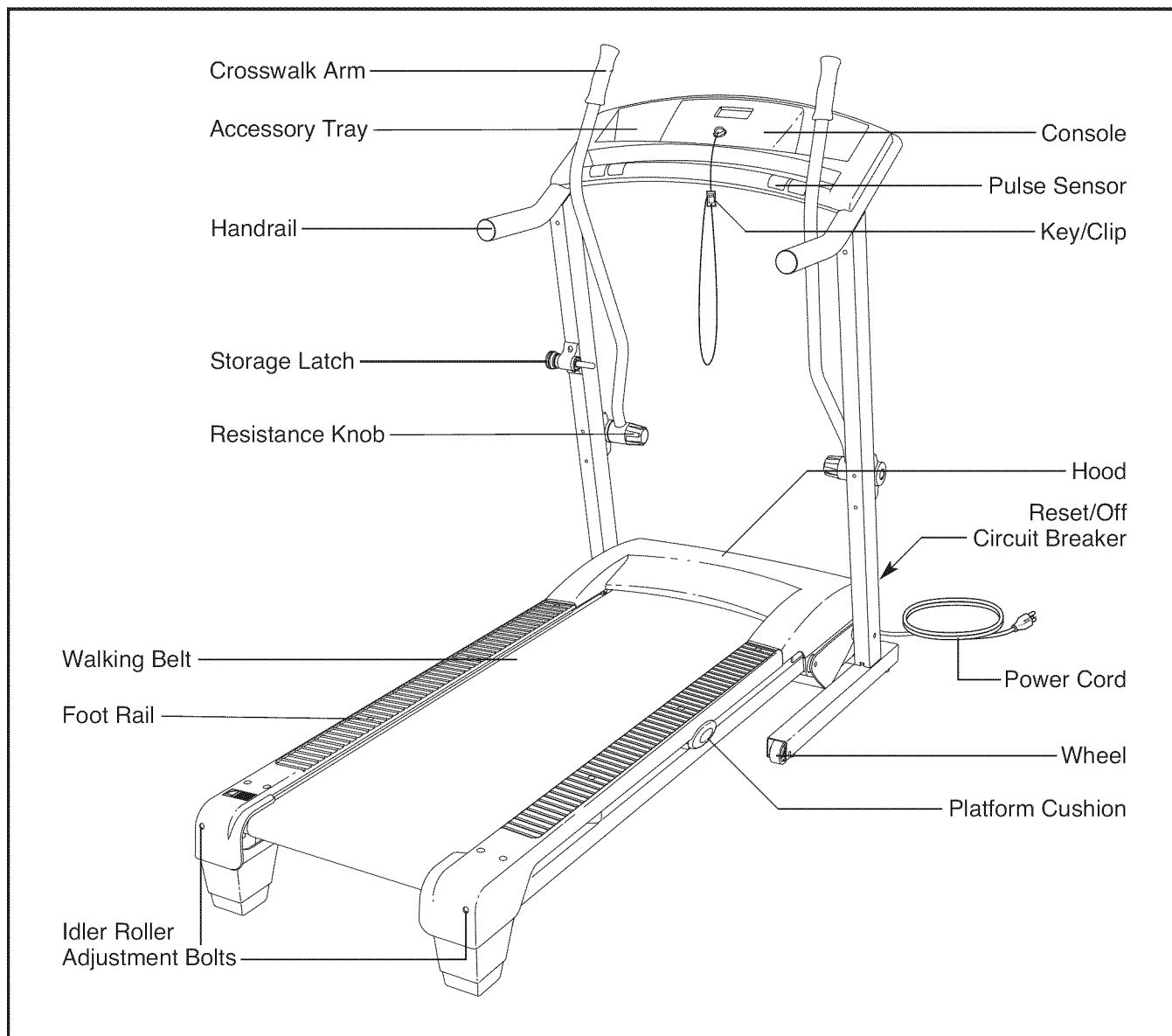

ing this manual, please see the back cover of this manual. To help us assist you, note the product model number and serial number before contacting us. The model number and the location of the serial number decal are shown on the front cover of this manual.

Before reading further, please review the drawing below and familiarize yourself with the labeled parts.

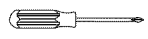

ASSEMBLY

Assembly requires two persons. Set the treadmill in a cleared area and remove all packing materials. **Do not dispose of the packing materials until assembly is completed.** Note: The underside of the treadmill walking belt is coated with high-performance lubricant. During shipping, a small amount of lubricant may be transferred to the top of the walking belt or the shipping carton. This is a normal condition and does not affect treadmill performance. If there is lubricant on top of the walking belt, simply wipe off the lubricant with a soft cloth and a mild, non-abrasive cleaner.

Assembly requires the included hex keys  **and your own Phillips screwdriver**  **, adjustable wrench**  **, scissors**  **, needlenose pliers**  **, and rubber mallet** .

Use the drawings below to identify the assembly hardware. The number in parentheses below each drawing is the key number of the part, from the PART LIST near the end of this manual. The number after the parentheses is the quantity needed for assembly. **Note: If a part is not in the hardware kit, check to see if it is preattached to one of the parts to be assembled. To avoid damaging plastic parts, do not use power tools for assembly. Extra hardware may be included. If a part is missing, call 1-888-533-1333.**

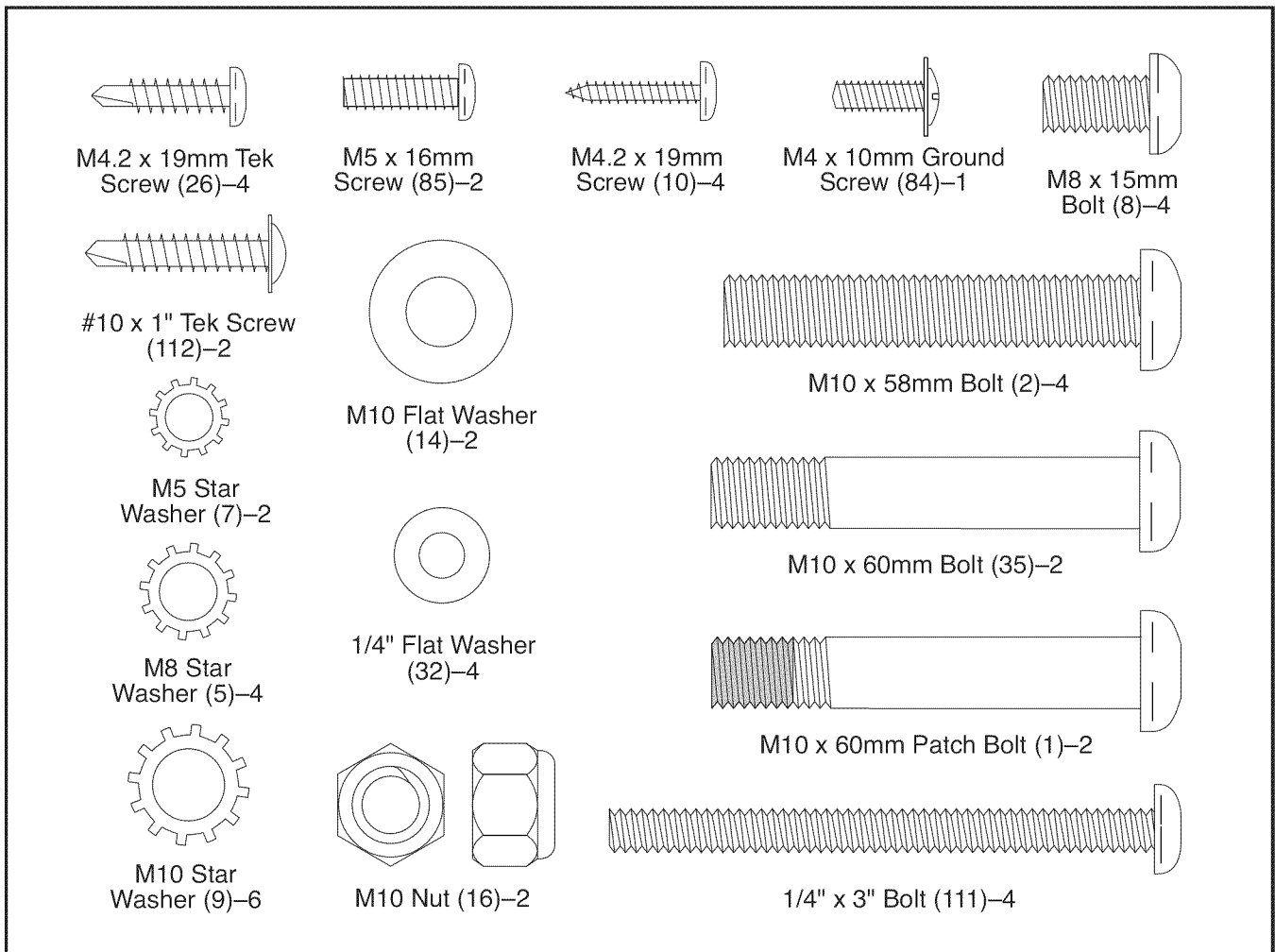

1. **Make sure that the power cord is unplugged.**

Position the Base (52) upside-down as shown.

Attach four Base Feet (63) to the Base (52) with four M4.2 x 19mm Tek Screws (26).

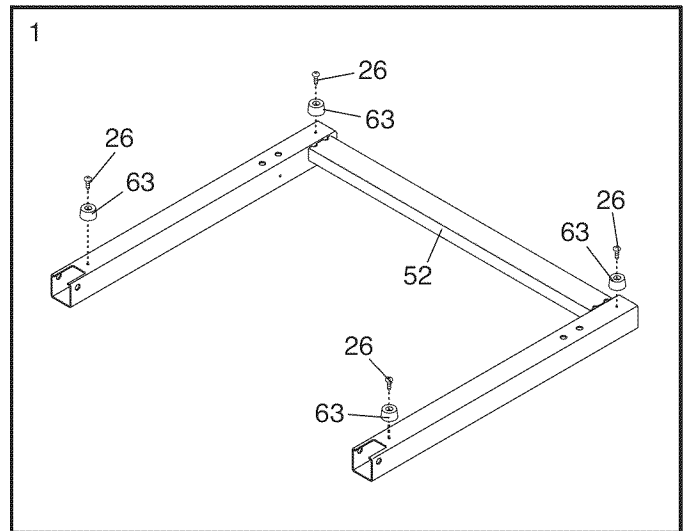

2. Attach the Wheels (70) to the Base (52) with two M10 Nuts (16), two M10 x 60mm Bolts (35) and four Wheel Spacers (69) as shown. **Do not over-tighten the Nuts; the Wheels should turn freely.**

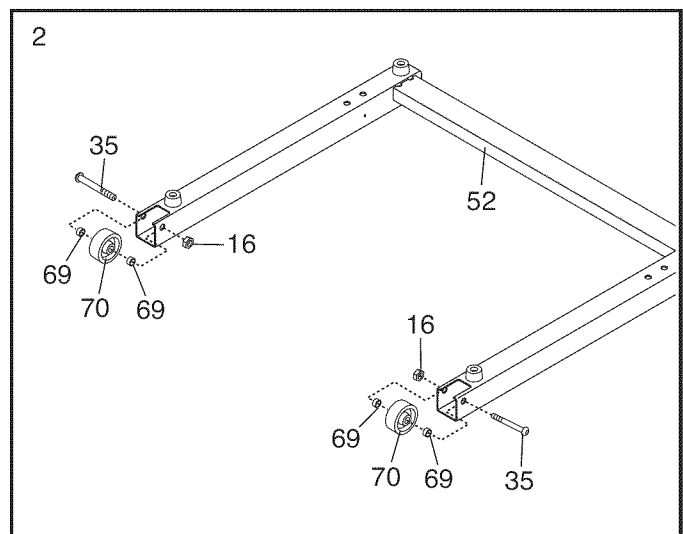

3. Have a second person hold the Base (52) in the position shown.

Identify the Left Upright (53) (the Right Upright [54] has a square hole near the lower end).

Hold the Left Upright (53) so that the small holes are positioned as shown. Attach the Left Upright (53) to the Base (52) with two M10 x 58mm Bolts (2) and two M10 Star Washers (9); **do not fully tighten the Bolts yet.**

Attach the Right Upright (54) to the Base (52) in the same way.

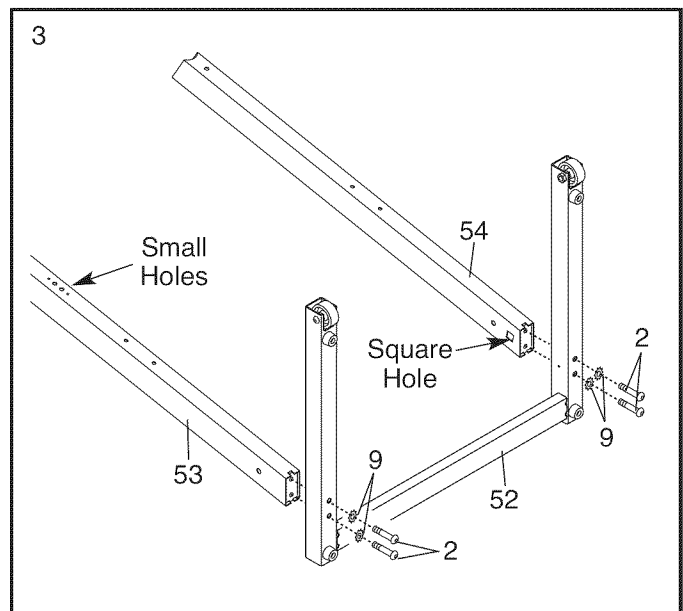

- Position the Base (52) as close to the front of the treadmill as possible, as shown.

See the upper inset drawing. Locate the wire tie in the lower end of the Right Upright (54). Tie the wire tie securely around the end of the Wire Harness (39). Then, locate the other end of the wire tie in the upper end of the Right Upright. Pull the upper end of the wire tie until the Wire Harness extends from the upper end of the Right Upright. Secure the Wire Harness to the Right Upright so that it will not fall inside.

See the lower inset drawing. Press the indicated Grommet (49) into the Right Upright (54).

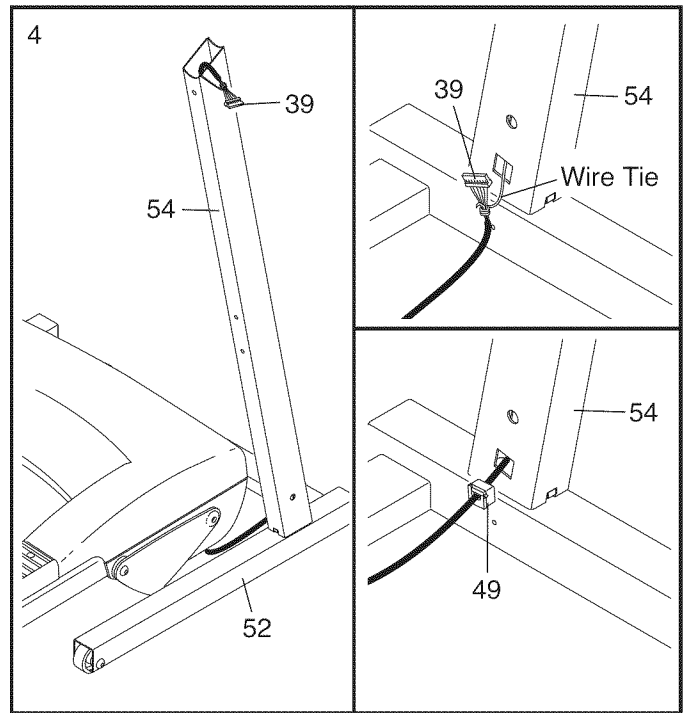

- See the left inset drawing.** Identify the two Frame Spacers (11). Open the included packet of grease, and apply grease to both sides of both Frame Spacers. Then, identify the outer side of each Frame Spacer.

Hold a Frame Spacer (11) between the Right Upright (54) and the Lift Frame (23), **with the outer side of the Frame Spacer facing the Right Upright.**

With the help of a second person, lift the front of the treadmill. Attach the Lift Frame (23) to the Right Upright (54) with an M10 x 60mm Patch Bolt (1), an M10 Flat Washer (14), and an M10 Star Washer (9); **do not fully tighten the Patch Bolt yet.**

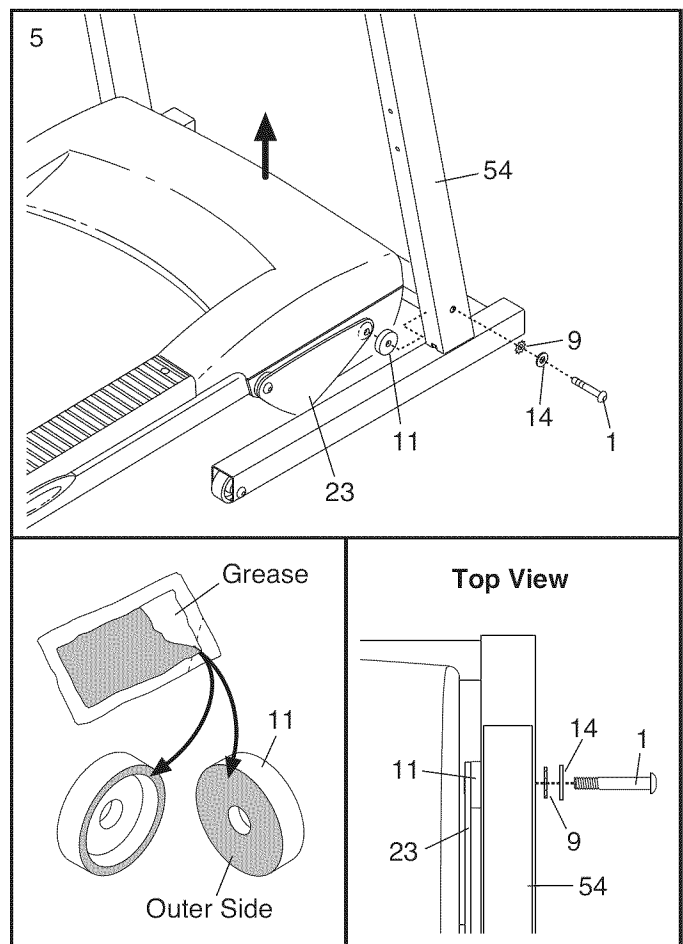

6. **See the left inset drawing in step 5.** Identify the outer side of the remaining Frame Spacer (11).

Hold the Frame Spacer (11) between the Left Upright (53) and the Lift Frame (23), **with the outer side of the Frame Spacer facing the Left Upright.** Attach the Left Upright to the Lift Frame with an M10 x 60mm Patch Bolt (1), an M10 Flat Washer (14), and an M10 Star Washer (9); **do not fully tighten the Patch Bolt yet.**

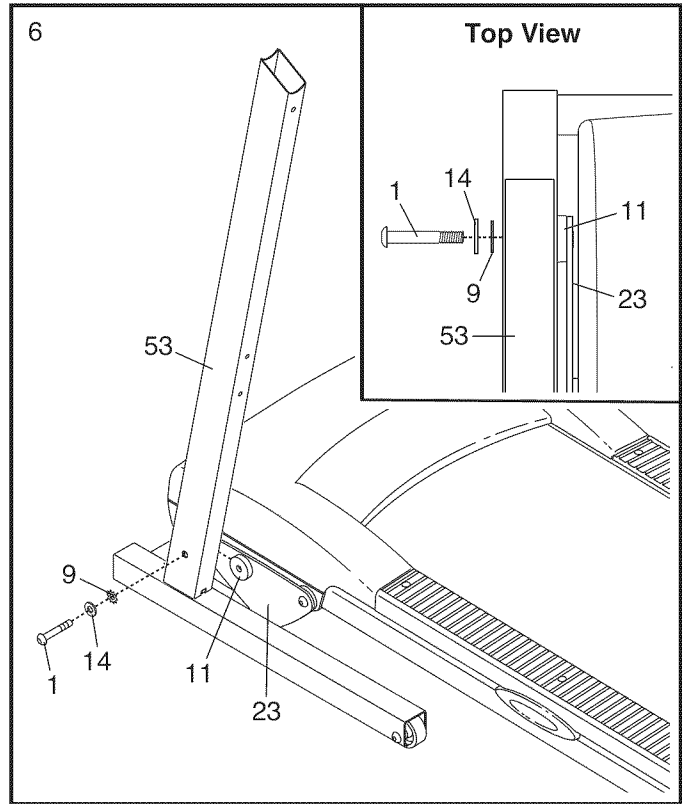

7. Set the Console Assembly (91) face down on a soft surface to avoid scratching the Console Assembly. Hold the Right Handrail (33), which has a large hole in one side, near the Console Assembly.

Next, insert the console wire and the tie into the hole in the side of the Right Handrail (33). Using needlenose pliers, pull the console wire out of the hole near the bracket on the Right Handrail.

See the inset drawing. Insert the included wire tie through the indicated small hole in the Right Handrail (33). **Make sure that the console wire has been secured to the side shown,** and tighten the wire tie.

Then, set the Right Handrail (33) on the Console Assembly (91). **Make sure that no wires are pinched.**

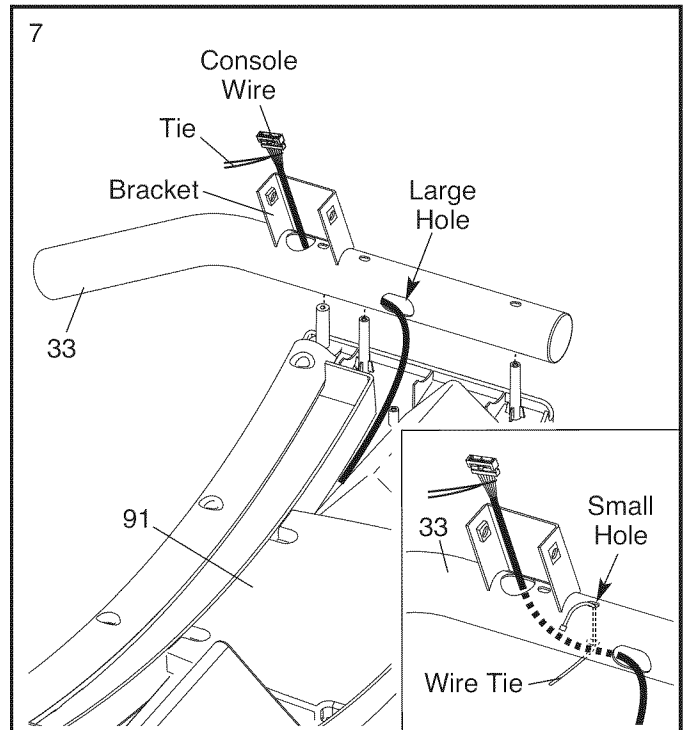

8. Start an M5 x 16mm Screw (85) with an M5 Star Washer (7) into the Right Handrail (33), and then start two M4.2 x 19mm Screws (10) into the Right Handrail. **Tighten the M5 x 16mm Screw and then tighten the two M4.2 x 19mm Screws; do not overtighten the Screws.**

Set the Left Handrail (not shown) on the Console Assembly (91). **Attach the Left Handrail to the Console Assembly in the same way.** Note: There are no wires on the left side.

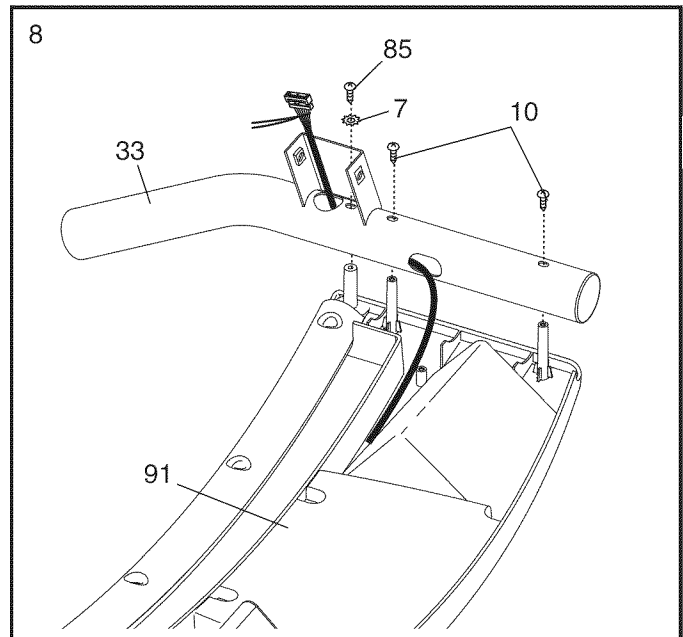

9. Remove the ties from the Cage Nuts (105) in the Right Handrail (33) and the Left Handrail (not shown). If necessary, press the Cage Nuts back into place. With the help of a second person, hold the Console Assembly (91) near the Right Upright (54).

Connect the Wire Harness (39) to the console wire. **See the inset drawing. The connectors should slide together easily and snap into place.** If they do not, turn one connector and try again. **IF THE CONNECTORS ARE NOT CONNECTED PROPERLY, THE CONSOLE MAY BE DAMAGED WHEN THE POWER IS TURNED ON.** Insert the connectors and the excess wire downward into the Right Upright (54). Remove the wire tie from the Wire Harness.

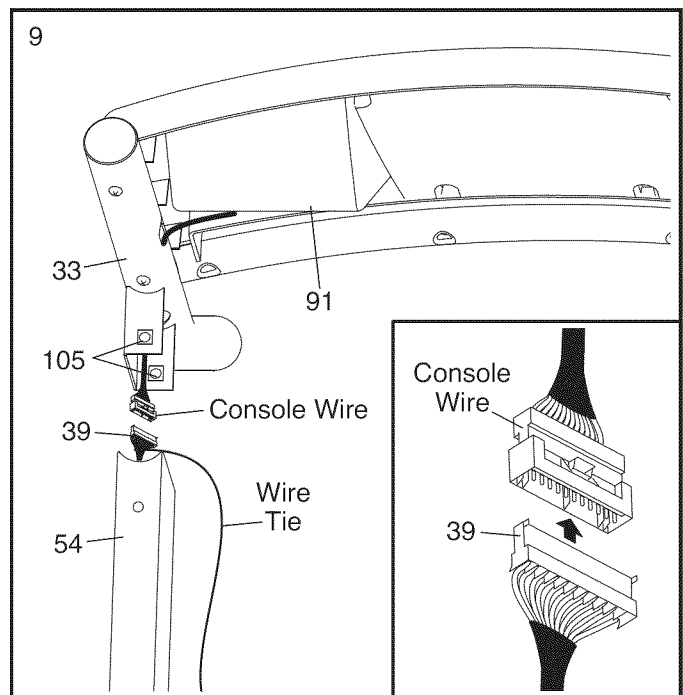

10. Set the Console Assembly (91) on the Right Upright (54) and the Left Upright (53). Start four M8 x 15mm Bolts (8) with four M8 Star Washers (5) into the Uprights (53, 54). **Then, firmly tighten all four M8 x 15mm Bolts.**

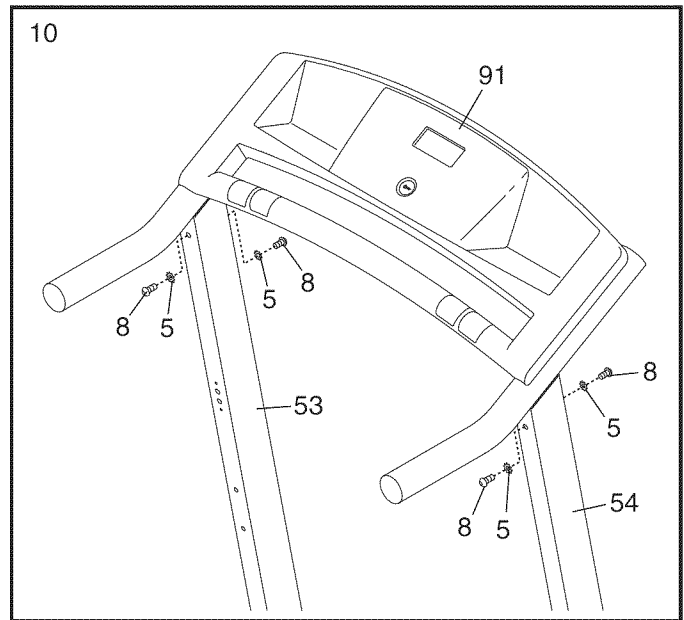

11. With the help of a second person, carefully lower the Left Upright (not shown) and the Right Upright (54) to the floor.

Attach the ground wire on the Wire Harness (39) to the indicated hole in the Base (52) with an M4 x 10mm Ground Screw (84).

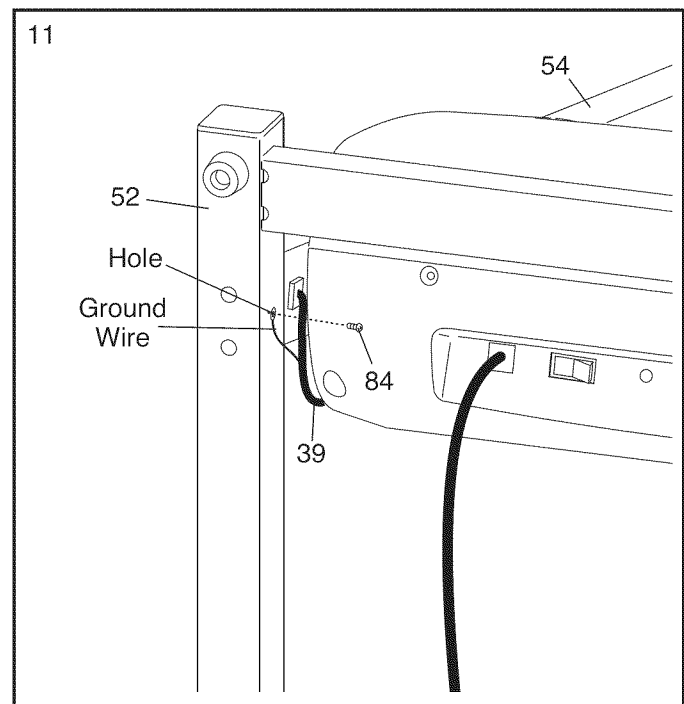

12. **See the lower drawing.** Position the Uprights (53, 54) so that the Frame (51) is centered between them.

Firmly tighten the two M10 x 60mm Patch Bolts (1) and the four M10 x 58mm Bolts (2) (only one side is shown). **Be careful not to overtighten the M10 x 60mm Patch Bolts.** Raise the Uprights (53, 54).

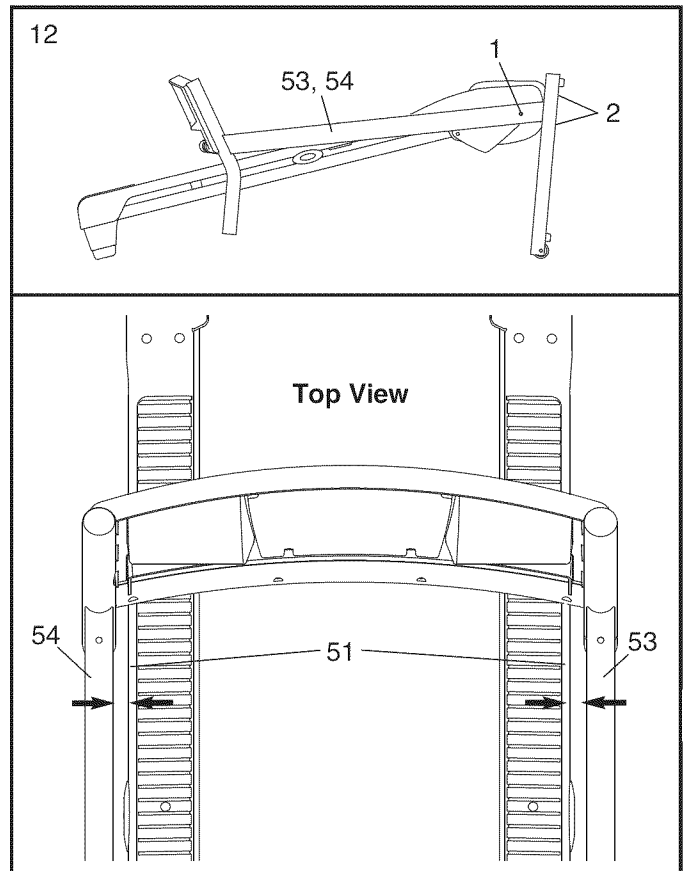

13. Attach the Latch Housing (48) to the Left Upright (53) with two #10 x 1" Tek Screws (112); **start both Tek Screws before tightening either of them. Make sure that the large hole in the Latch Housing is on the indicated side.**

Locate the Latch Pin Assembly (24). Remove the knob from the pin. Make sure that the collar and the spring are on the pin. (Note: If there are two collars, place one on each side of the spring.) Insert the pin into the Latch Housing (48). Then, tighten the knob onto the pin.

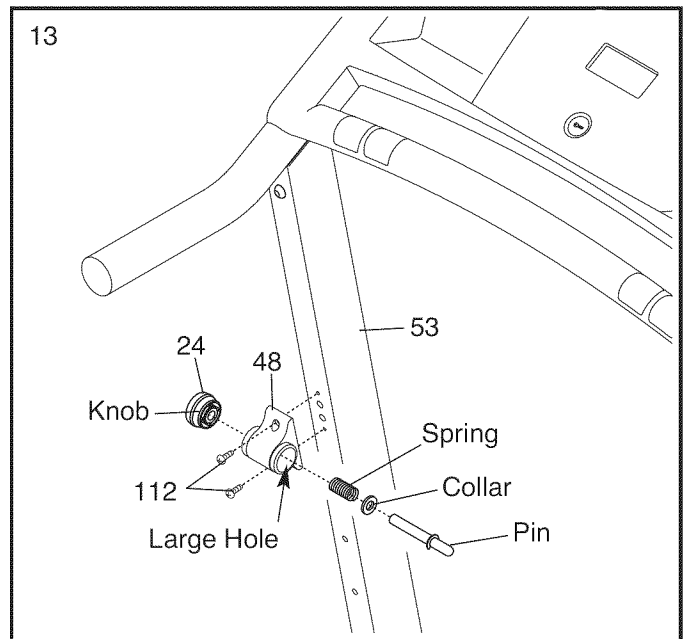

14. Attach the Left Crosswalk Arm (73) to the Left Upright (53) with two 1/4" Flat Washers (32) and two 1/4" x 3" Bolts (111). **Make sure that the Left Crosswalk Arm is on the indicated side of the Console Assembly (91).**

Attach the Right Crosswalk Arm (not shown) in the same way. Be careful not to pinch the wires in the Right Upright (not shown).

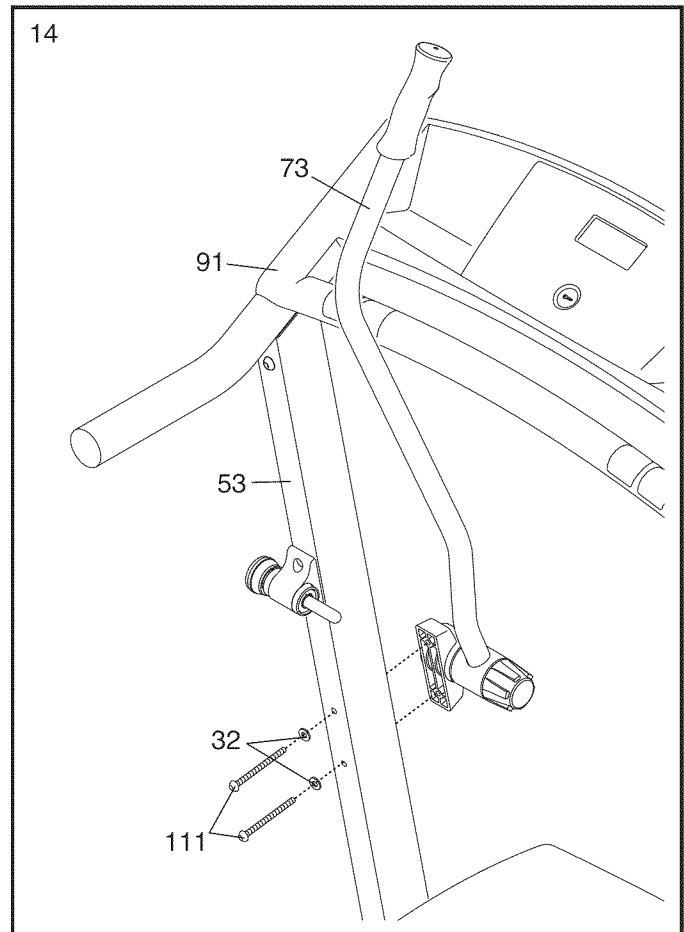

15. **Make sure that all parts are properly tightened before you use the treadmill.** Keep the included hex keys in a secure place. One hex key is used to adjust the walking belt (see page 23). To protect the floor or carpet, place a mat under the treadmill.

OPERATION AND ADJUSTMENT

THE PRE-LUBRICATED WALKING BELT

Your treadmill features a walking belt coated with high-performance lubricant. **IMPORTANT: Never apply silicone spray or other substances to the walking belt or the walking platform. Such substances will deteriorate the walking belt and cause excessive wear.**

HOW TO PLUG IN THE POWER CORD

⚠ DANGER: Improper connection of the equipment-grounding conductor can result in an increased risk of electric shock. Check with a qualified electrician or serviceman if you are in doubt as to whether the product is properly grounded. Do not modify the plug provided with the product—if it will not fit the outlet, have a proper outlet installed by a qualified electrician.

Your treadmill, like any other type of sophisticated electronic equipment, can be seriously damaged by sudden voltage changes in your home's power. Voltage surges, spikes, and noise interference can result from weather conditions or from other appliances being turned on or off. **To decrease the possibility of your treadmill being damaged, always use a surge suppressor with your treadmill (see drawing 1 at the right). To purchase a surge suppressor, see your local Sears store or call the telephone number on the back cover of this manual and order part number 146148, or see your local electronics store.**

Use only a single-outlet surge suppressor that is UL 1449 listed as a transient voltage surge suppressor (TVSS). The surge suppressor must have a UL suppressed voltage rating of 400 volts or less and a minimum surge dissipation of 450 joules. The surge suppressor must be electrically rated for 120 volts AC and 15 amps. There must be a monitoring light on the surge suppressor to indicate whether it is functioning properly. Failure to use a properly functioning surge suppressor could result in damage to the control system of the treadmill. If the control system is damaged, the walking belt may change speed, accelerate or stop unexpectedly, which may result in a fall and serious injury.

This product must be grounded. If it should malfunction or break down, grounding provides a path of least resistance for electric current to reduce the risk of elec-

tric shock. This product is equipped with a cord having an equipment-grounding conductor and a grounding plug. **Plug the power cord into a surge suppressor, and plug the surge suppressor into an appropriate outlet that is properly installed and grounded in accordance with all local codes and ordinances. IMPORTANT: The treadmill is not compatible with GFCI-equipped outlets.**

This product is for use on a nominal 120-volt circuit, and has a grounding plug that looks like the plug illustrated in drawing 1 below. A temporary adapter that looks like the adapter illustrated in drawing 2 may be used to connect the surge suppressor to a 2-pole receptacle as shown in drawing 2 if a properly grounded outlet is not available.

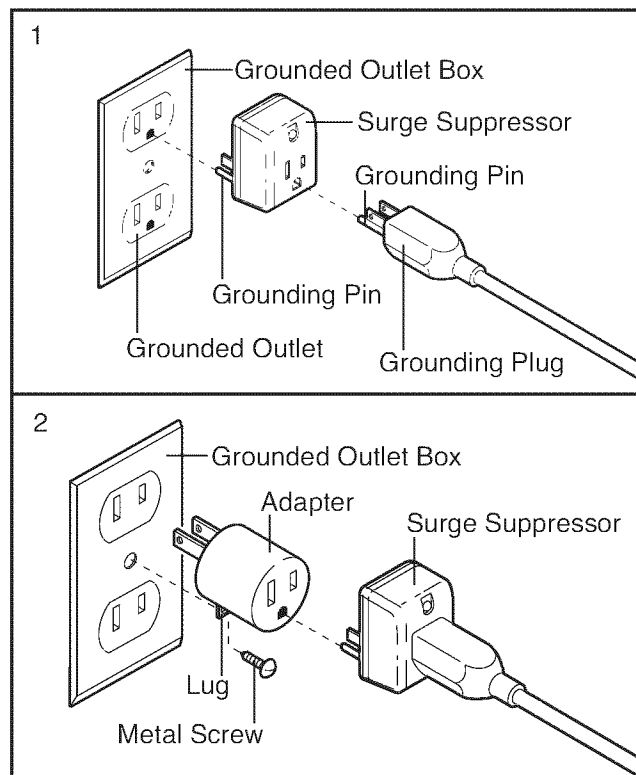

The temporary adapter should be used only until a properly grounded outlet (drawing 1) can be installed by a qualified electrician.

The green-colored rigid ear, lug, or the like extending from the adapter must be connected to a permanent ground such as a properly grounded outlet box cover. Whenever the adapter is used it must be held in place by a metal screw. **Some 2-pole receptacle outlet box covers are not grounded. Contact a qualified electrician to determine if the outlet box cover is grounded before using an adapter.**

CONSOLE DIAGRAM

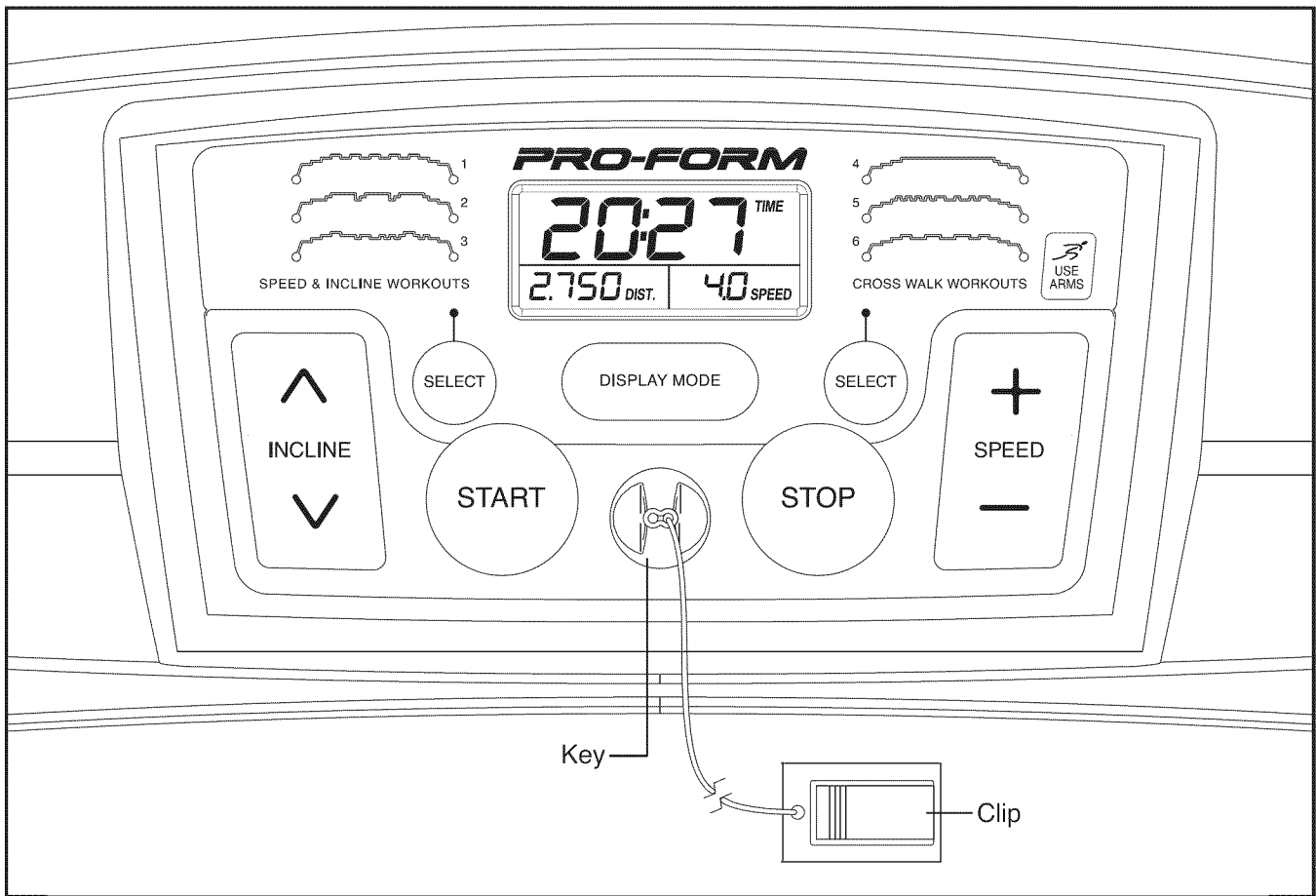

FEATURES OF THE CONSOLE

The treadmill console offers a selection of features designed to make your workouts more effective. When you select the manual mode of the console, you can change the speed and incline of the treadmill with the touch of a button. As you exercise, the displays will provide continuous exercise feedback. You can even measure your heart rate using the built-in pulse sensor.

The console also features three preset speed and incline workouts. Each workout controls the speed and incline of the treadmill as it guides you through an effective exercise session. In addition, the console offers three preset crosswalk workouts that automatically control the speed and incline of the treadmill and prompt you to use the crosswalk arms for a total body workout.

To turn on the power, see page 16. **To use the manual mode,** see page 16. **To use a preset workout,**

see page 18. **To use the information mode,** see page 19.

IMPORTANT: If there is a sheet of clear plastic on the face of the console, remove the plastic. To prevent damage to the walking platform, wear clean athletic shoes while using the treadmill. The first time the treadmill is used, observe the alignment of the walking belt, and center the walking belt if necessary (see page 23).

Note: The console can display speed and distance in either miles or kilometers. To find which unit of measurement is selected or to change the unit of measurement, see THE INFORMATION MODE on page 19. For simplicity, all instructions in this manual refer to miles.

HOW TO TURN ON THE POWER

IMPORTANT: If the treadmill has been exposed to cold temperatures, allow it to warm to room temperature before turning on the power. If you do not do this, you may damage the console displays or other electrical components.

Plug in the power cord (see page 14). Next, locate the reset/off circuit breaker on the treadmill frame near the power cord. Switch the circuit breaker to the reset position.

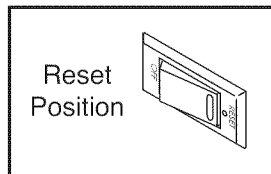

IMPORTANT: The console features a display demo mode, designed to be used if the treadmill is displayed in a store. If the displays light as soon as you plug in the power cord and switch the reset/off circuit breaker to the reset position, the demo mode is turned on. To turn off the demo mode, hold down the Stop button for a few seconds. If the displays remain lit, see THE INFORMATION MODE on page 19 to turn off the demo mode.

Next, stand on the foot rails of the treadmill. Find the clip attached to the key (see the drawing on page 15) and slide the clip onto the waistband of your clothes. Then, insert the key into the console. After a moment, the displays will light. **IMPORTANT:** In an emergency situation, the key can be pulled from the console, causing the walking belt to slow to a stop. Test the clip by carefully taking a few steps backward; if the key is not pulled from the console, adjust the position of the clip.

HOW TO USE THE MANUAL MODE

1. Insert the key into the console.

See HOW TO TURN ON THE POWER at the left.

2. Select the manual mode.

When the key is inserted, the manual mode will be selected. If you have selected a speed workout, reselect the manual mode by pressing one of the Select buttons repeatedly until only zeros appear in the displays.



3. Start the walking belt.

To start the walking belt, press the Start button or the Speed increase button. The walking belt will begin to move at 1 mph. As you exercise, change the speed of the walking belt as desired by pressing the Speed increase and decrease buttons. Each time you press a button, the speed setting will change by 0.1 mph; if you hold down a button, the speed setting will change in increments of 0.5 mph. Note: After you press the buttons, it may take a moment for the walking belt to reach the selected speed setting.

To stop the walking belt, press the Stop button. If the time is shown, the time will begin to flash in the display. To restart the walking belt, press the Start button or the Speed increase button.

4. Change the incline of the treadmill as desired.

To change the incline of the treadmill, press the Incline increase or decrease button. Each time you press one of the buttons, the incline will gradually increase or decrease until it reaches the selected incline setting.



5. Follow your progress with the displays.

The lower left display—

As you exercise, the lower left display can show the elapsed time, the distance that you have walked or run, and the incline level of the treadmill each time the incline level changes. Note: When a preset workout is selected, the display will show the time remaining in the workout instead of the elapsed time.



The lower right display—

The lower right display can show the speed of the walking belt and the approximate number of calories that you have burned. The display also shows your heart rate when you use the handgrip pulse sensor (see step 6 at the right).

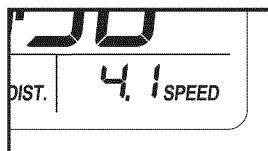

The upper display—

The upper display can show the elapsed time, the distance that you have walked or run, the approximate number of calories you have burned, or the speed of the walking belt. Press the Display Mode button repeatedly until the upper display shows the information that you are most interested in viewing. Note: While information is shown in the upper display, the same information will not be shown in the lower left or lower right display.

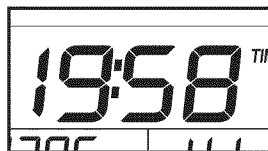

To reset the displays, press the Stop button, remove the key, and then reinsert the key.

6. Measure your heart rate if desired.

Before using the handgrip pulse sensor, remove the sheets of clear plastic from the metal contacts. In addition, make sure that your hands are clean.

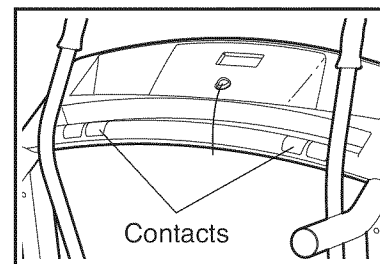

To measure your heart rate, **stand on the foot rails and hold the contacts for approximately 10 seconds—avoid moving your hands.** When your pulse is detected, a heart symbol will flash in the lower right display each time your heart beats, one or two dashes will appear, and then your heart rate will be shown. **For the most accurate heart rate reading, continue to hold the contacts for about 15 seconds.**

7. When you are finished exercising, remove the key from the console.

Step onto the foot rails, press the Stop button, and **adjust the incline of the treadmill to the lowest setting. The incline must be at the lowest setting or you may damage the treadmill when you fold it to the storage position.** Next, remove the key from the console and put it in a secure place.

When you are finished using the treadmill, switch the reset/off circuit breaker to the “off” position and unplug the power cord. **IMPORTANT: If you do not do this, the treadmill’s electrical components may wear prematurely.**

HOW TO USE A PRESET WORKOUT

1. Insert the key into the console.

See HOW TO TURN ON THE POWER on page 16.

2. Select one of the six preset workouts.

To select a speed and incline workout, repeatedly press the Select button below the speed and incline profiles on the console; “P 1,” “P 2,” or “P 3” will appear in the upper display for a few seconds. To select a crosswalk workout, repeatedly press the Select button below the crosswalk profiles on the console; “P 4,” “P 5,” or “P 6” will appear in the upper display for a few seconds. The maximum incline setting and maximum speed setting of the selected workout will also flash in the displays for a few seconds and the crosswalk indicator will light up. Then, the duration of the workout will appear in the display.

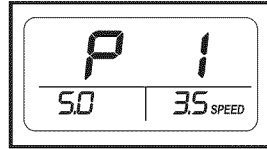

Each workout is divided into 30 one-minute segments. One speed setting and one incline setting are programmed for each segment. Note: The same speed and incline settings may be programmed for consecutive segments.

3. Press the Start button or the Speed increase button to start the workout.

A moment after you press the button, the treadmill will automatically adjust to the first speed and incline settings for the workout. Hold the handrails and begin walking.

At the end of each segment, a series of tones will sound. If a different speed or incline setting is programmed for the next segment, the speed or incline setting will flash in the display to alert you and the treadmill will automatically adjust to the new speed and incline settings.

The workout will continue in this way until the last segment ends. The walking belt will then slow to a stop.

If you have selected a crosswalk workout, you will be prompted to use the crosswalk arms. When the crosswalk indicator on the console lights up, move the crosswalk arms forward and backward as you walk or run on the treadmill. This action exercises your arms, shoulders, and back for a total body workout.

If the speed or incline setting is too high or too low at any time during the workout, you can manually override the setting by pressing the speed or incline buttons; **however, when the next segment of the workout begins, the treadmill will automatically adjust to the speed and incline settings for the next segment.**

To stop the workout at any time, press the Stop button. To restart the workout, press the Start button or the Speed increase button. The walking belt will begin to move at 1 mph. When the next segment of the workout begins, the treadmill will automatically adjust to the speed and incline settings for the next segment.

4. Change the incline of the treadmill as desired.

See step 4 on page 16.

5. Follow your progress with the displays.

See step 5 on page 17.

6. Measure your heart rate if desired.

See step 6 on page 17.

7. When you are finished exercising, remove the key from the console.

See step 7 on page 17.

THE INFORMATION MODE

The console features an information mode that keeps track of treadmill usage information and allows you to select a unit of measurement for the console. You can also turn on and turn off the display demo mode.

To select the information mode, insert the key into the console while holding down the Stop button. When the information mode is selected, the following information will be shown:

The upper display will show the total number of hours that the treadmill has been used.

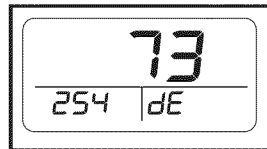

The lower left display will show the total number of miles or kilometers that the walking belt has moved.

An "E" for English miles or an "M" for metric kilometers will appear in the lower right display. Press the Speed increase button to change the unit of measurement, if desired.

The console features a display demo mode, designed to be used if the treadmill is displayed in a store. While the demo mode is turned on, the console will function normally when you plug in the power cord, switch the reset/off circuit breaker to the reset position, and insert the key into the console. However, when you remove the key, the displays will remain lit, although the buttons will not function. If the demo mode is turned on, a "d" will appear in the lower right display while the information mode is selected. To turn on or turn off the demo mode, press the Speed decrease button.

To exit the information mode, remove the key from the console.

HOW TO USE THE CROSSWALK ARMS

As you walk on the treadmill, you can hold the handrails or use the crosswalk arms. To exercise your arms, shoulders, and back for a total body workout, move the crosswalk arms forward and backward as you walk on the treadmill.

To vary the intensity of your upper body exercise, the resistance of the crosswalk arms can be adjusted. To increase the resistance, turn the resistance knobs clockwise; to decrease the resistance, turn the knobs counterclockwise.

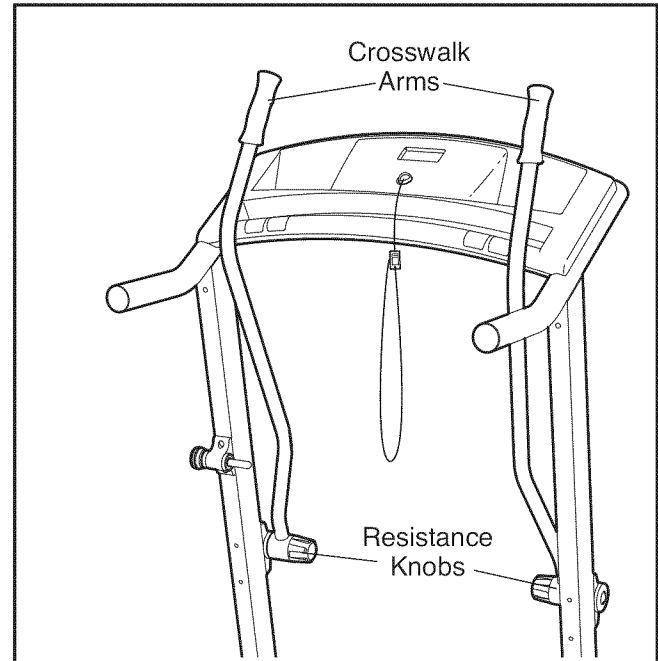

HOW TO FOLD AND MOVE THE TREADMILL

HOW TO FOLD THE TREADMILL FOR STORAGE

Before folding the treadmill, adjust the incline to the lowest position. If you do not do this, you may damage the treadmill when you fold it. Next, remove the key and unplug the power cord. **CAUTION:** You must be able to safely lift 45 lbs. (20 kg) to raise, lower, or move the treadmill.

1. Hold the metal frame firmly in the location shown by the arrow at the right. **CAUTION:** To decrease the possibility of injury, do not lift the frame by the plastic foot rails. Make sure you bend your legs and keep your back straight. As you raise the frame, lift with your legs rather than with your back. Raise the frame about halfway to the vertical position.

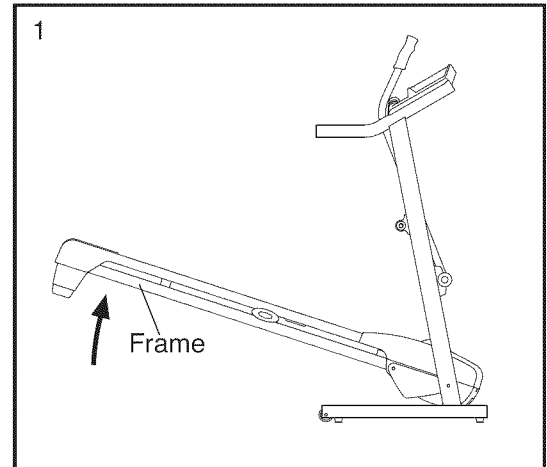

2. Move your right hand to the position shown and hold the treadmill firmly. Using your left hand, pull the latch knob to the left and hold it. Raise the frame until the latch plate is past the latch pin, and then slowly release the latch knob. **Make sure that the frame is held securely by the latch pin.**

To protect the floor or carpet from damage, place a mat under the treadmill. Keep the treadmill out of direct sunlight. Do not leave the treadmill in the storage position in temperatures above 85° F (30° C).

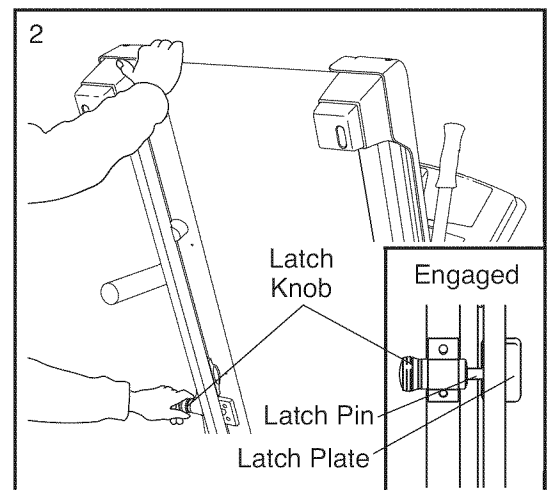

HOW TO MOVE THE TREADMILL

Before moving the treadmill, convert the treadmill to the storage position as described above. **Make sure that the frame is held securely by the latch pin.**

1. Hold one handrail and place one foot against one of the wheels. **Do not pull back on the frame.**
2. Tilt the treadmill back until it rolls freely on the wheels. Carefully move the treadmill to the desired location. **To reduce the risk of injury, use extreme caution while moving the treadmill. Do not move the treadmill over an uneven surface.**
3. Place one foot against one of the wheels, and carefully lower the treadmill until it is resting in the storage position.

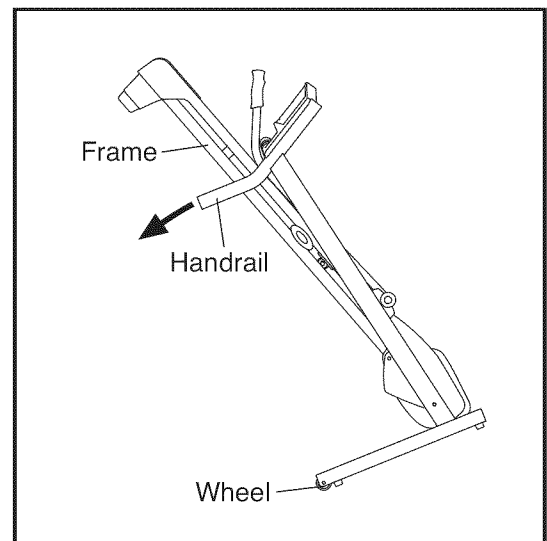

HOW TO LOWER THE TREADMILL FOR USE

1. Hold the frame with your right hand as shown. Pull the latch knob to the left and hold it. Pivot the frame down until it is past the latch pin. Then, release the latch knob.

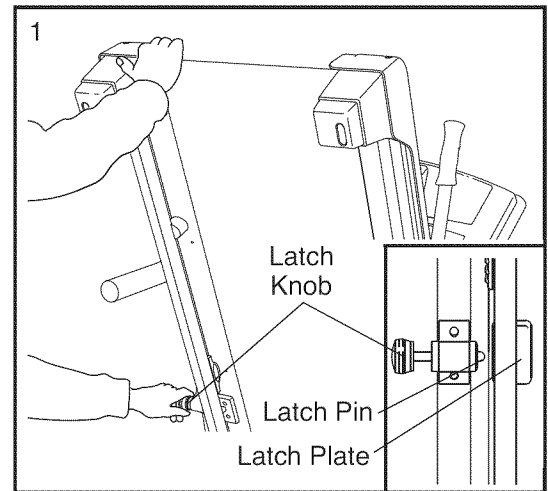

2. **Hold the metal frame firmly with both hands**, and lower it to the floor. **CAUTION: To decrease the possibility of injury, do not lower the frame by gripping only the plastic foot rails. Do not drop the frame to the floor. Make sure to bend your legs and keep your back straight.**

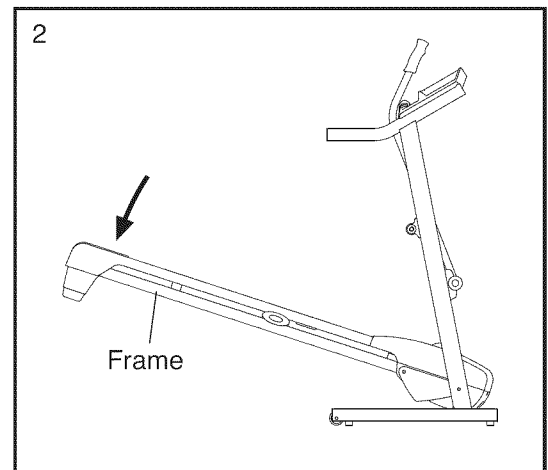

TROUBLESHOOTING

Most treadmill problems can be solved by following the steps below. Find the symptom that applies, and follow the steps listed. If further assistance is needed, see the back cover of this manual.

PROBLEM: The power does not turn on

SOLUTION: a. Make sure that the power cord is plugged into a surge suppressor, and that the surge suppressor is plugged into a properly grounded outlet (see page 14). Use only a single-outlet surge suppressor that meets all of the specifications described on page 14. **IMPORTANT: The treadmill is not compatible with GFCI-equipped outlets.**

b. After the power cord has been plugged in, make sure that the key is inserted into the console.

c. Check the reset/off circuit breaker located on the treadmill frame near the power cord. If the switch protrudes as shown, the circuit breaker has tripped. To reset the circuit breaker, wait for five minutes, and then press the switch back in.

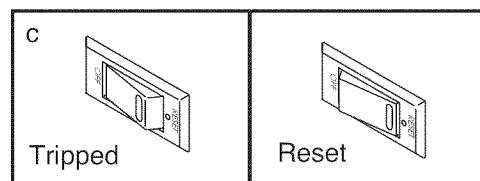

PROBLEM: The power turns off during use

SOLUTION: a. Check the reset/off circuit breaker (see the drawing above). If the circuit breaker has tripped, wait for five minutes and then press the switch back in.

b. Make sure that the power cord is plugged in.

c. Remove the key from the console. Reinsert the key into the console.

d. If the treadmill still will not run, please see the back cover of this manual.

PROBLEM: The console displays remain lit when you remove the key from the console

SOLUTION: a. The console features a display demo mode, designed to be used if the treadmill is displayed in a store. If the displays remain lit when you remove the key, the demo mode is turned on. To turn off the demo mode, hold down the Stop button for a few seconds. If the displays are still lit, see THE INFORMATION MODE on page 19 to turn off the demo mode.

PROBLEM: The displays of the console do not function properly

SOLUTION: a. Remove the key from the console and **UNPLUG THE POWER CORD**. Remove the three indicated M4.2 x 19mm Hood Screws (20) and two M5.5 x 25mm Screws (25). Then, carefully remove the Motor Hood (65).

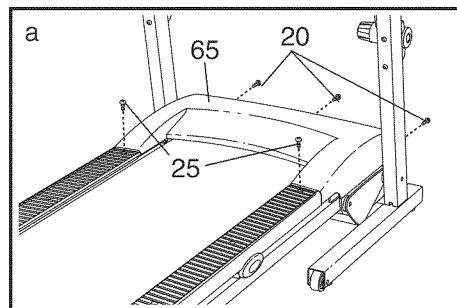

Locate the Reed Switch (89) and the Magnet (62) on the left side of the Pulley (71). Turn the Pulley until the Magnet is aligned with the Reed Switch. **Make sure that the gap between the Magnet and the Reed Switch is about 1/8 in. (3 mm).** If necessary, loosen the M4.2 x 13mm Tek Screw (3), move the Reed Switch slightly, and then retighten the Screw. Reattach the Motor Hood (not shown), and run the treadmill for a few minutes to check for a correct speed reading.

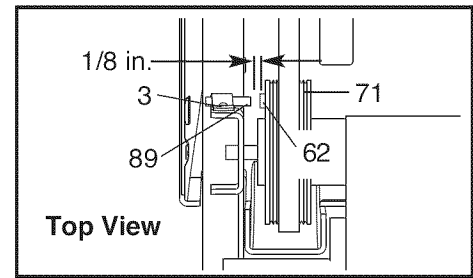

PROBLEM: The walking belt slows when walked on

SOLUTION: a. Use only a single-outlet surge suppressor that meets all of the specifications described on page 14.

b. If the walking belt is overtightened, treadmill performance may decrease and the walking belt may become damaged. Remove the key and **UNPLUG THE POWER CORD.** Using the hex key, turn both idler roller bolts counterclockwise, 1/4 of a turn. When the walking belt is properly tightened, you should be able to lift each edge of the walking belt 2 to 3 in. (5 to 7 cm) off the walking platform. Be careful to keep the walking belt centered. Then, plug in the power cord, insert the key, and run the treadmill for a few minutes. Repeat until the walking belt is properly tightened.

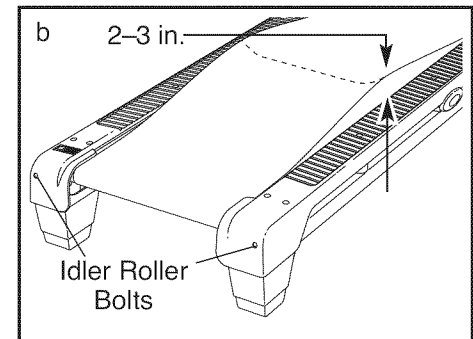

c. If the walking belt still slows when walked on, please see the back cover of this manual.

PROBLEM: The walking belt is off-center or slips when walked on

SOLUTION: a. **If the walking belt has shifted to the left**, first remove the key and **UNPLUG THE POWER CORD.** Using the hex key, turn the left idler roller bolt clockwise 1/2 of a turn. Be careful not to overtighten the walking belt. **If the walking belt has shifted to the right**, turn the left idler roller bolt counterclockwise 1/2 of a turn. Then, plug in the power cord, insert the key, and run the treadmill for a few minutes. Repeat until the walking belt is centered.

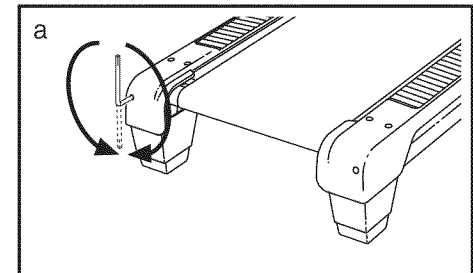

b. **If the walking belt slips when walked on**, first remove the key and **UNPLUG THE POWER CORD.** Using the hex key, turn both idler roller bolts clockwise, 1/4 of a turn. When the walking belt is correctly tightened, you should be able to lift each edge of the walking belt 2 to 3 in. (5 to 7 cm) off the walking platform. Be careful to keep the walking belt centered. Then, plug in the power cord, insert the key, and carefully walk on the treadmill for a few minutes. Repeat until the walking belt is properly tightened.

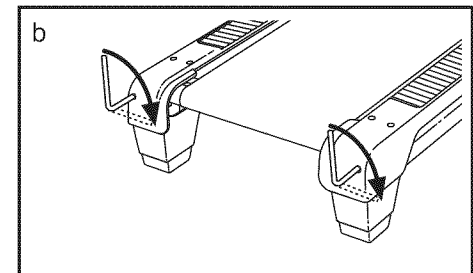

PROBLEM: The crosswalk arms squeak during use

SOLUTION: a. (Note: Correcting this problem requires a small amount of white marine grease, available at hardware stores.) Turn the Resistance Knob (A) counterclockwise and remove it. Next, remove the Resistance Cone (B) and the Left Crosswalk Arm (73), along with the Resistance Plate (C), Washers (D), Spring Washer (E), Thrust Washers (F), and Thrust Bearing (G). (Note: If the Resistance Plate [C] comes out of the Resistance Cone [B], press it back in.) Apply a **thin layer** of white marine grease to the outer surface of the Resistance Cone (B). Then, reattach all parts in the order shown at the right.

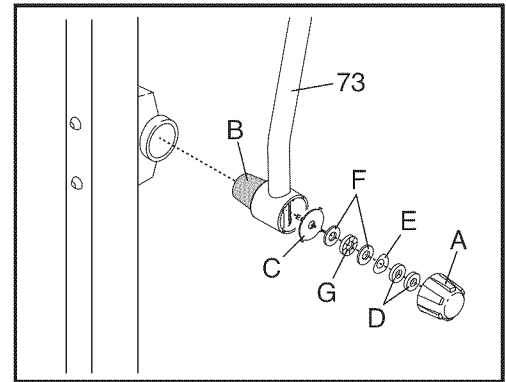

PROBLEM: The incline of the treadmill does not change correctly

SOLUTION: a. With the key in the console, press one of the Incline buttons. **While the incline is changing, remove the key.** After a few seconds, re-insert the key. The treadmill will automatically rise to the maximum incline level and then return to the minimum level. This will recalibrate the incline system.

EXERCISE GUIDELINES

⚠️ WARNING: Before beginning this or any exercise program, consult your physician. This is especially important for individuals over age 35 or individuals with pre-existing health problems.

The pulse sensor is not a medical device. Various factors, including your movement, may affect the accuracy of heart rate readings. The sensor is intended only as an exercise aid in determining heart rate trends in general.

These guidelines will help you to plan your exercise program. For detailed exercise information, obtain a reputable book or consult your physician. Remember, proper nutrition and adequate rest are essential for successful results.

EXERCISE INTENSITY

Whether your goal is to burn fat or to strengthen your cardiovascular system, exercising at the proper intensity is the key to achieving results. You can use your heart rate as a guide to find the proper intensity level. The chart below shows recommended heart rates for fat burning and aerobic exercise.

165	155	145	140	130	125	115	♥
145	138	130	125	118	110	103	♥
125	120	115	110	105	95	90	♥
<hr/>							
20	30	40	50	60	70	80	

To find the proper intensity level, find your age at the bottom of the chart (ages are rounded off to the nearest ten years). The three numbers listed above your age define your “training zone.” The lowest number is the heart rate for fat burning, the middle number is the heart rate for maximum fat burning, and the highest number is the heart rate for aerobic exercise.

Burning Fat—To burn fat effectively, you must exercise at a low intensity level for a sustained period of time. During the first few minutes of exercise, your body uses *carbohydrate calories* for energy. Only after the first few minutes of exercise does your body begin to use stored *fat calories* for energy. If your goal is to burn fat, adjust the intensity of your exercise until your heart rate is near the lowest number in your training zone. For maximum fat burning, exercise with your heart rate near the middle number in your training zone.

Aerobic Exercise—If your goal is to strengthen your cardiovascular system, you must perform aerobic exercise, which is activity that requires large amounts of oxygen for prolonged periods of time. For aerobic exercise, adjust the intensity of your exercise until your heart rate is near the highest number in your training zone.

WORKOUT GUIDELINES

Warming Up—Start with 5 to 10 minutes of stretching and light exercise. A warm-up increases your body temperature, heart rate, and circulation in preparation for exercise.

Training Zone Exercise—Exercise for 20 to 30 minutes with your heart rate in your training zone. (During the first few weeks of your exercise program, do not keep your heart rate in your training zone for longer than 20 minutes.) Breathe regularly and deeply as you exercise—never hold your breath.

Cooling Down—Finish with 5 to 10 minutes of stretching. Stretching increases the flexibility of your muscles and helps to prevent post-exercise problems.

EXERCISE FREQUENCY

To maintain or improve your condition, complete three workouts each week, with at least one day of rest between workouts. After a few months of regular exercise, you may complete up to five workouts each week, if desired. Remember, the key to success is to make exercise a regular and enjoyable part of your everyday life.

PART LIST—Model No. 831.24803.1

R1008A

To locate the parts listed below, see the EXPLODED DRAWING near the end of this manual.

Key No.	Qty.	Description	Key No.	Qty.	Description
1	2	M10 x 60mm Patch Bolt	51	1	Frame
2	6	M10 x 58mm Bolt	52	1	Base
3	2	M4.2 x 13mm Tek Screw	53	1	Left Upright
4	6	M4.2 x 16mm Screw	54	1	Right Upright
5	4	M8 Star Washer	55	1	Idler Roller
6	1	Latch Warning Decal	56	1	Drive Motor Belt
7	2	M5 Star Washer	57	1	Electronics Bracket
8	4	M8 x 15mm Bolt	58	1	3/8" x 1 3/4" Bolt
9	6	M10 Star Washer	59	1	Motor Bracket
10	12	M4.2 x 19mm Screw	60	1	Left Idler Roller Bracket
11	4	Frame Spacer	61	1	Right Idler Roller Bracket
12	1	Console Back	62	1	Magnet
13	2	Crosswalk Arm Insert	63	4	Base Foot
14	2	M10 Flat Washer	64	1	Latch Plate
15	1	Key/Clip	65	1	Motor Hood
16	4	M10 Nut	66	1	Belly Pan
17	1	6 mm Hex Key	67	1	Left Foot Rail
18	1	4 mm Hex Key	68	1	Right Foot Rail
19	4	M8 x 30mm Screw	69	4	Wheel Spacer
20	3	M4.2 x 19mm Hood Screw	70	2	Wheel
21	6	M4.2 x 13mm Screw	71	1	Drive Roller/Pulley
22	1	Left Handrail	72	1	3/8" x 1 1/4" Bolt
23	1	Lift Frame	73	1	Left Crosswalk Arm
24	1	Latch Pin Assembly	74	1	Rear Foot, Left
25	6	M5.5 x 25mm Screw	75	4	M5.5 x 30mm Screw
26	4	M4.2 x 19mm Tek Screw	76	1	Walking Belt
27	2	M8 x 35mm Screw	77	4	Handrail Cap
28	4	M4.2 x 13mm Belt Guide Screw	78	2	Platform Cushion
29	2	Idler Roller Adjustment Bolt	79	1	Drive Motor
30	2	1/4" Motor Bolt	80	2	Wire Tie
31	1	M8 x 102mm Bolt	81	12	8" Tie
32	4	1/4" Flat Washer	82	1	3/8" Locknut
33	1	Right Handrail	83	1	Reed Switch Clamp
34	2	M8 x 20mm Bolt	84	2	M4 x 10mm Ground Screw
35	2	M10 x 60mm Bolt	85	2	M5 x 16mm Screw
36	2	M6 Star Washer	86	1	Walking Platform
37	1	Reset/Off Circuit Breaker	87	1	Controller
38	2	M8.4 Star Washer	88	1	Console Crossbar
39	1	Wire Harness	89	1	Reed Switch
40	1	Incline Motor	90	1	Power Cord
41	4	M 4.2 x 13mm Belly Pan Screw	91	1	Console Assembly
42	4	M 4.2mm Star Washer	92	1	3/8" Jam Nut
43	1	Hex Key	93	2	Belt Guide
44	6	M8 Flange Nut	94	1	5mm Hex Key
45	2	Hand Grip	95	2	Frame Cap
46	1	M8 Jam Nut	96	1	Releasable Tie
47	3	Hood Clip	97	1	Rear Foot, Right
48	1	Latch Housing	98	1	Filter Wire
49	2	Grommet	99	1	Power Cord Grommet
50	4	Isolator Fastener	100	1	Incline Motor Wire

Key No.	Qty.	Description	Key No.	Qty.	Description
101	2	Front Roller Washer	110	2	#10 x 3/4" Screw
102	3	M4.2 x 18mm Screw	111	4	1/4" x 3" Bolt
103	1	Right Crosswalk Arm	112	2	#10 x 1" Tek Screw
104	2	Base Cap	*	–	6" Red Wire, M/F
105	4	Cage Nut	*	–	8" Black Wire, M/F
106	2	Caution Decal	*	–	4" Blue Wire, 2F
107	2	Isolator	*	–	4" Black Wire, M/F
108	2	M4 x 10mm Controller Screw	*	–	10" White Wire, M/F
109	2	Resistance Assembly	*	–	User's Manual

Note: Specifications are subject to change without notice. See the back cover of this manual for information about ordering replacement parts. **If a part is missing, call 1-888-533-1333.** *These parts are not illustrated.

EXPLODED DRAWING A—Model No. 831.24803.1

R1008A

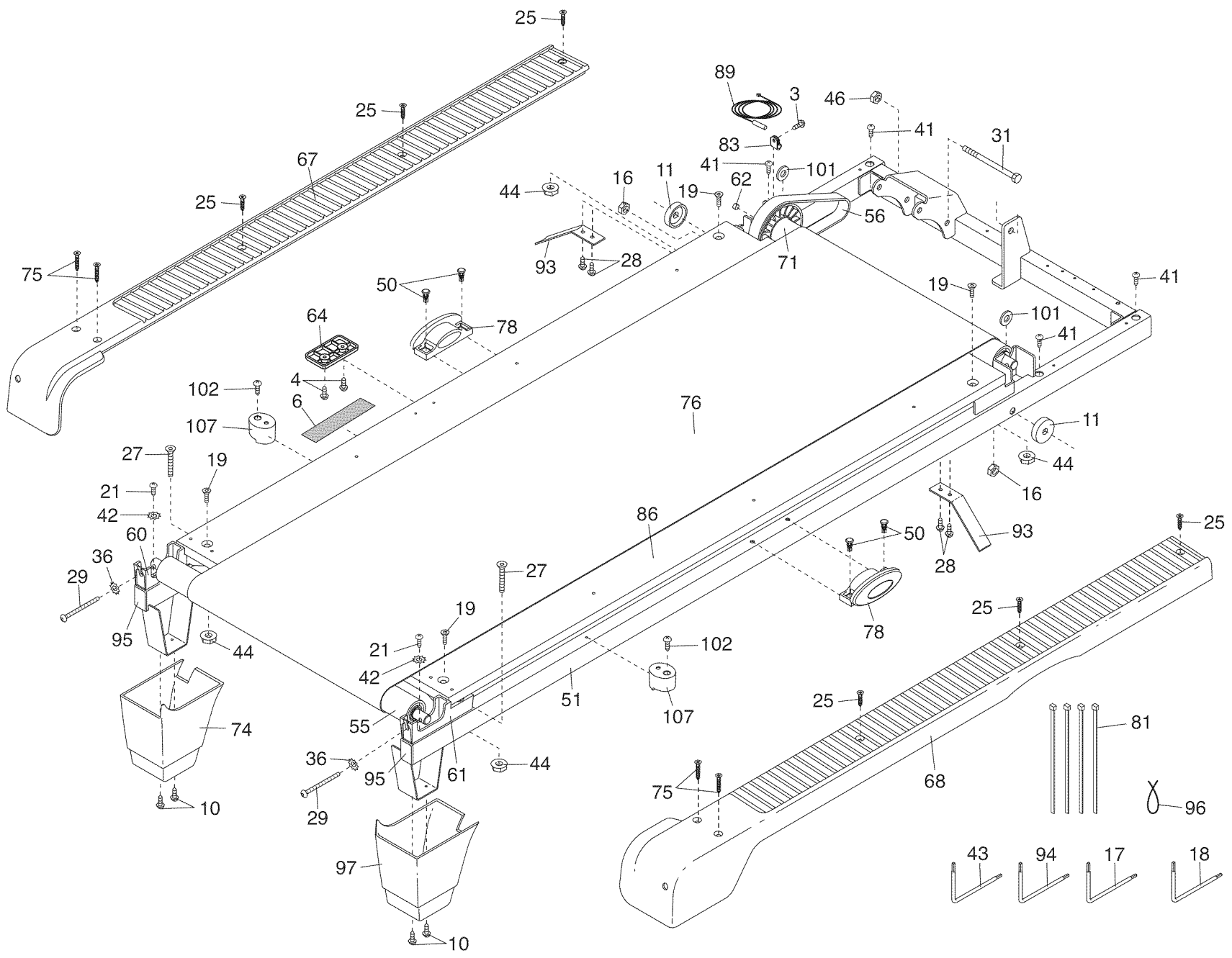

28

EXPLODED DRAWING B—Model No. 831.24803.1

R1008A

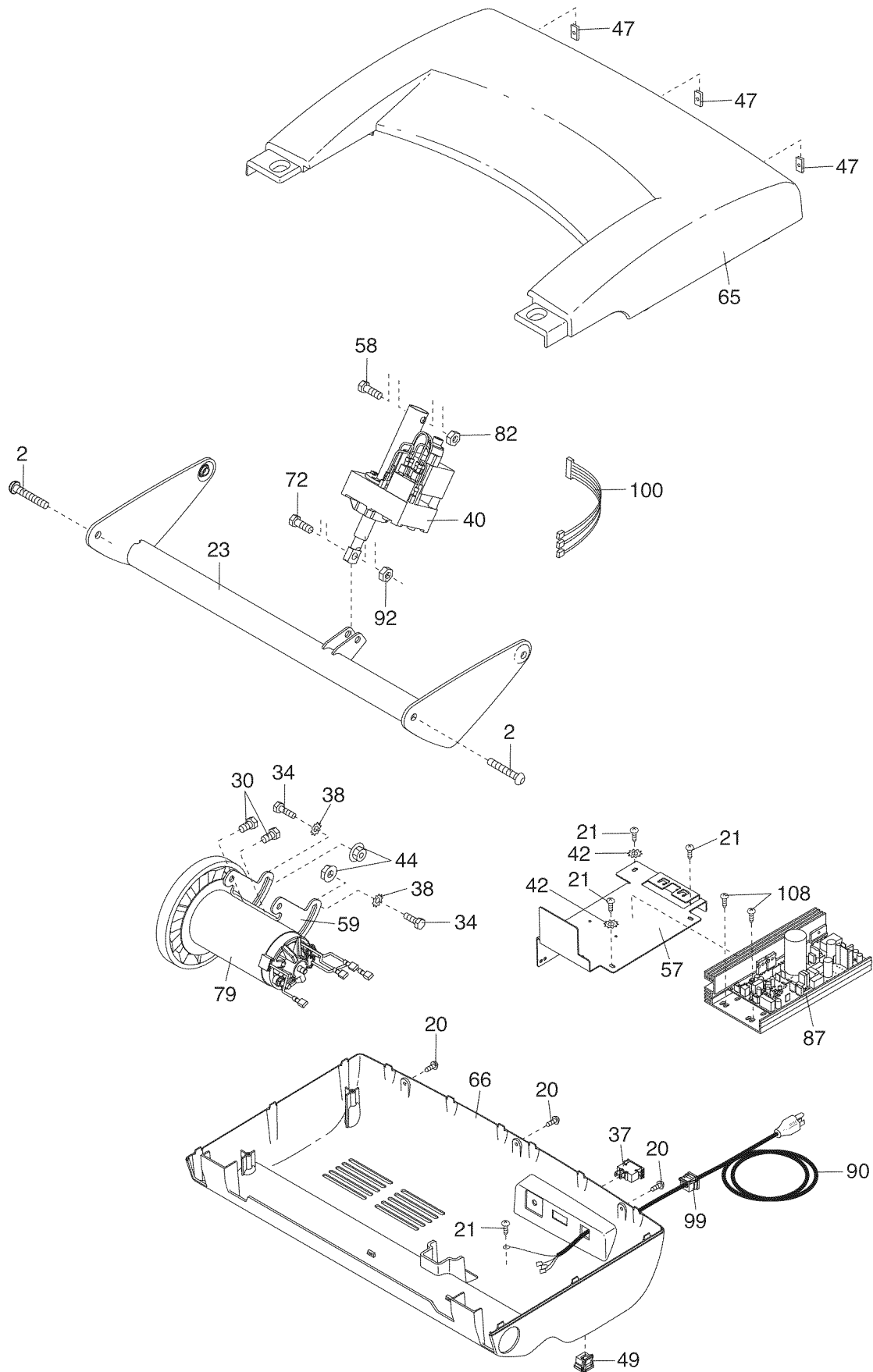

EXPLODED DRAWING C—Model No. 831.24803.1

R1008A

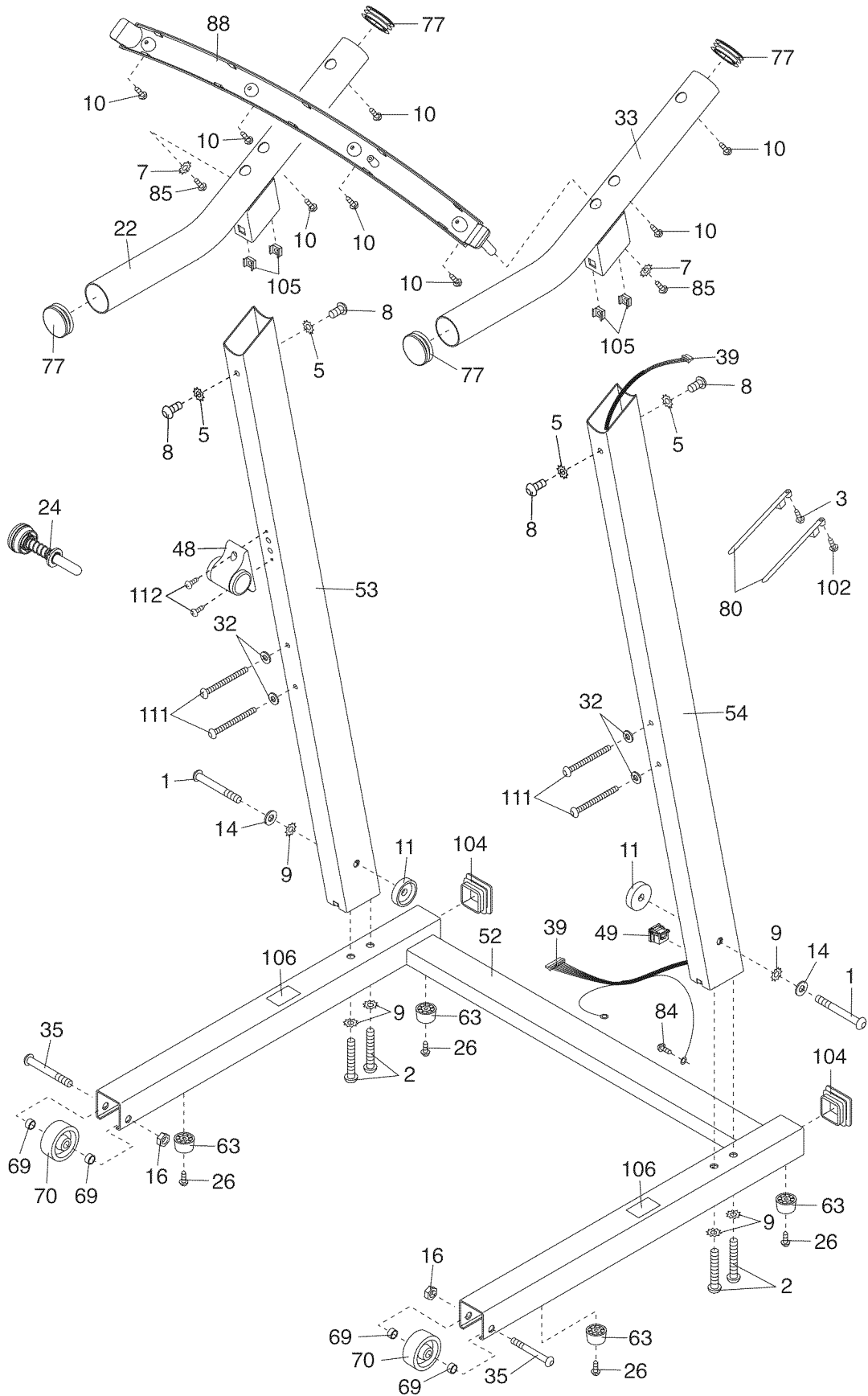

EXPLODED DRAWING D—Model No. 831.24803.1

R1008A

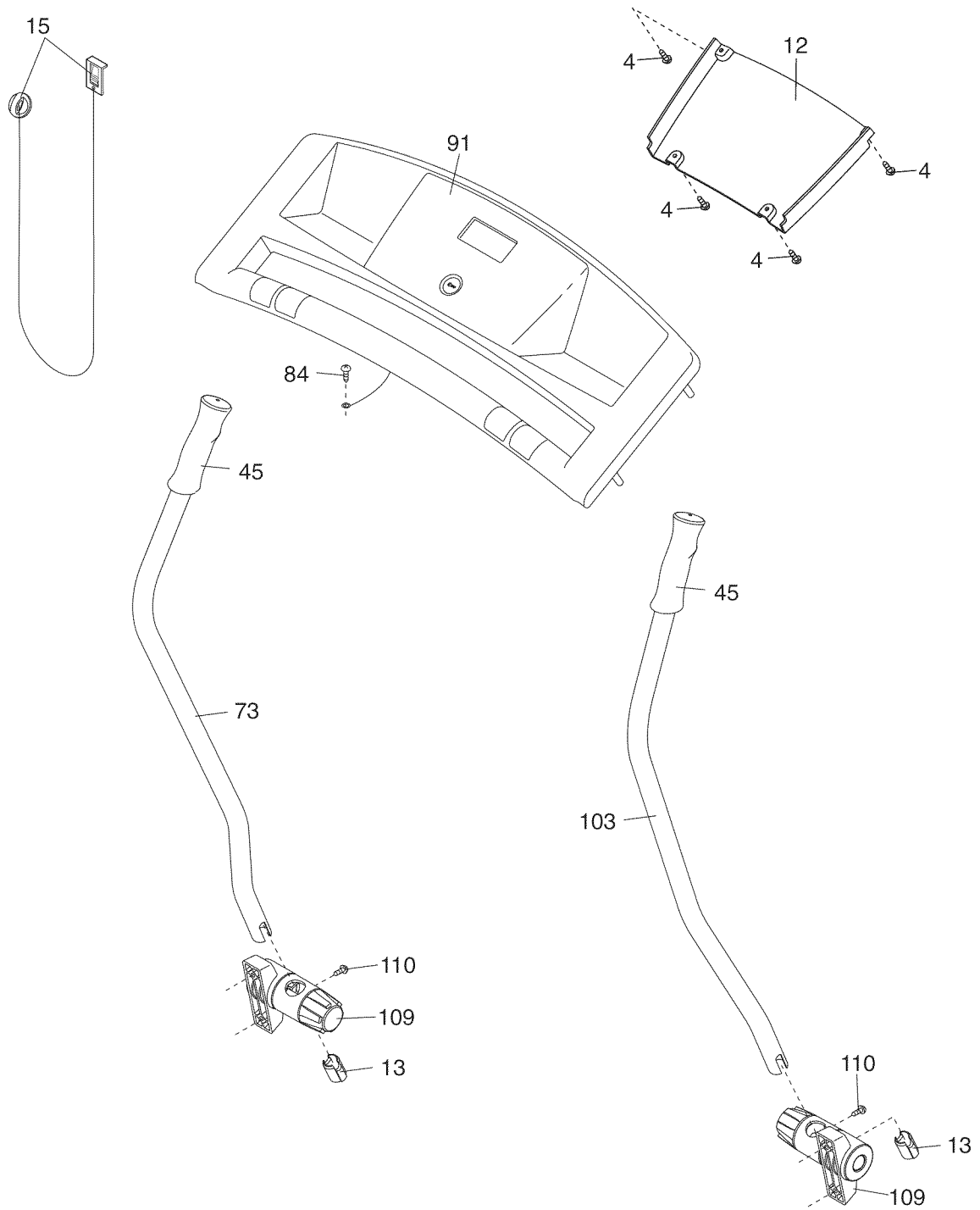

Get it fixed, at your home or ours!

Your Home

For repair—in **your home**—of **all** major brand appliances, lawn and garden equipment, or heating and cooling systems, **no matter who made it, no matter who sold it!**

For the replacement parts, accessories, and user's manuals that you need to do-it-yourself.

For Sears professional installation of home appliances and items like garage door openers and water heaters.

1-800-4-MY-HOME® (1-800-469-4663)

Call anytime, day or night (U.S.A. and Canada)

www.sears.com

www.sears.ca

Our Home

For repair of carry-in items like vacuums, lawn equipment, and electronics, call or go on-line for the location of your nearest **Sears Parts & Repair Center.**

1-800-488-1222 Call anytime, day or night (U.S.A. only)

www.sears.com

To purchase a protection agreement (U.S.A.) or maintenance agreement (Canada) on a product serviced by Sears:

1-800-827-6655 (U.S.A.)

1-800-361-6665 (Canada)

Para pedir servicio de reparación a domicilio, y para ordenar piezas:

1-888-SU-HOGAR® (1-888-784-6427)



® Registered Trademark / ™ Trademark / ™ Service Mark of Sears Brands, LLC
® Marca Registrada / ™ Marca de Fábrica / ™ Marca de Servicio de Sears Brands, LLC

90 DAY FULL WARRANTY

If this Sears Treadmill Exerciser fails due to a defect in material or workmanship within 90 days of the date of purchase, call 1-800-4-MY-HOME® (1-800-469-4663) to arrange for free repair (or replacement if repair proves impossible). The drive motor is warranted for 5 years from the date of purchase.

This warranty does not apply when the Treadmill Exerciser is used commercially or for rental purposes.

This warranty gives you specific legal rights, and you may also have other rights which vary from state to state.

Sears, Roebuck and Co., Hoffman Estates, IL 60179