

PRO-FORM[®] XP 90

Patent Pending

Model No. 831.21522.1

Serial No. _____

Write the serial number in the space above for reference.

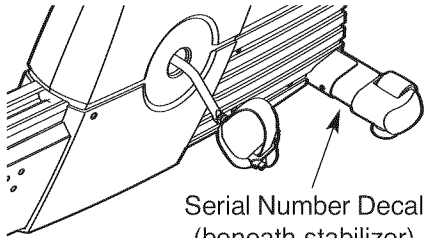

- Assembly
- Operation
- Maintenance
- Part List and Drawing

CAUTION

Read all precautions and instructions in this manual before using this equipment. Keep this manual for future reference.

BIKE EXERCISER User's Manual

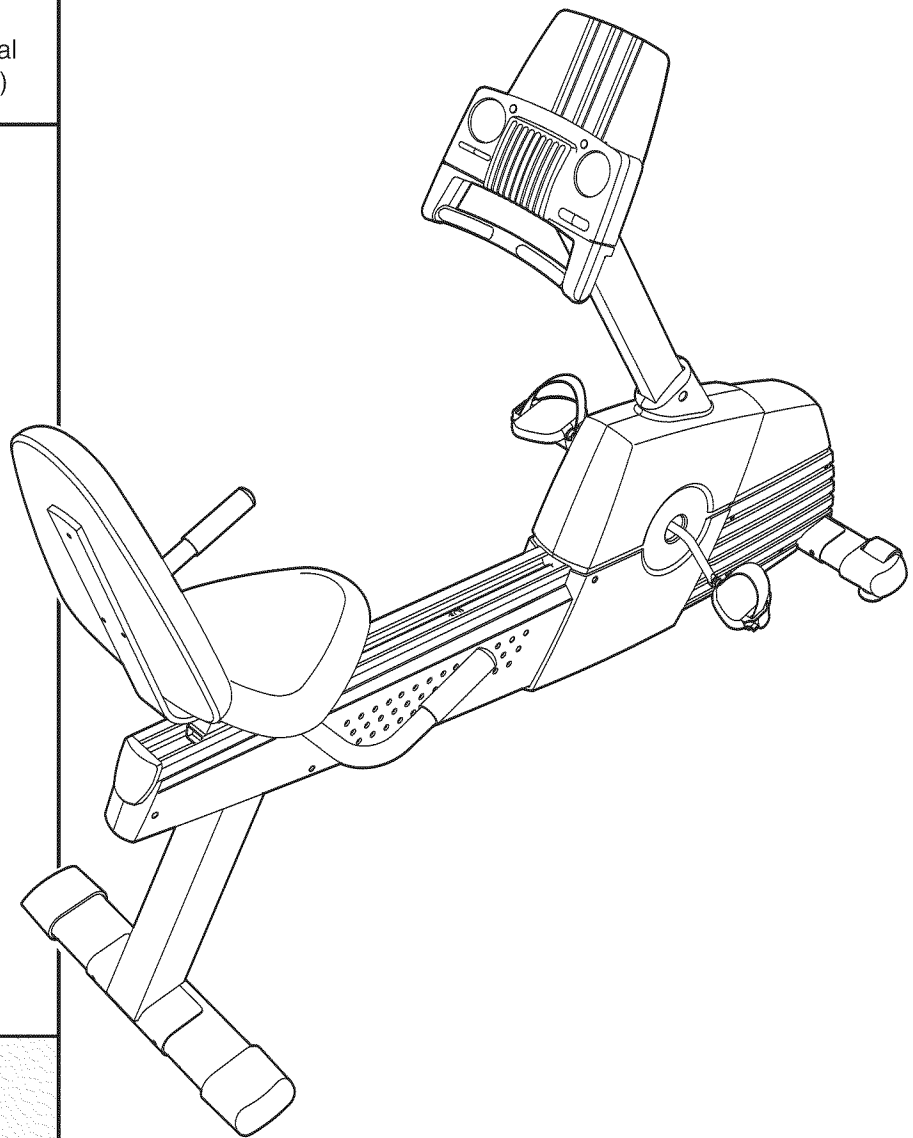

Sears, Roebuck and Co., Hoffman Estates, IL 60179

TABLE OF CONTENTS

IMPORTANT PRECAUTIONS	2
BEFORE YOU BEGIN	3
ASSEMBLY	4
HOW TO OPERATE THE EXERCISE CYCLE	8
MAINTENANCE AND TROUBLESHOOTING	19
CONDITIONING GUIDELINES	20
PART LIST	21
EXPLODED DRAWING	22
HOW TO ORDER REPLACEMENT PARTS	Back Cover
90 DAY FULL WARRANTY	Back Cover

IMPORTANT PRECAUTIONS

⚠ WARNING: To reduce the risk of serious injury, read the following important precautions before using the exercise cycle.

1. Read all instructions in this manual and all warnings on the exercise cycle before using the exercise cycle. Use the exercise cycle only as described in this manual.
2. It is the responsibility of the owner to ensure that all users of the exercise cycle are adequately informed of all precautions.
3. The exercise cycle is intended for home use only. Do not use the exercise cycle in a commercial, rental, or institutional setting.
4. Keep the exercise cycle indoors, away from moisture and dust. Place the exercise cycle on a level surface, with a mat beneath it to protect the floor. Make sure that there is enough clearance around the exercise cycle to mount, dismount, and use the exercise cycle.
5. Inspect and properly tighten all parts regularly. Replace any worn parts immediately.
6. Keep children under the age of 12 and pets away from the exercise cycle at all times.
7. The exercise cycle should not be used by persons weighing more than 250 pounds.
8. Wear appropriate clothes when exercising; do not wear loose clothes that could become caught on the exercise cycle. Always wear athletic shoes for foot protection.
9. The pulse sensor is not a medical device. Various factors, including the user's movement, may affect the accuracy of heart rate readings. The pulse sensor is intended only as an exercise aid in determining heart rate trends in general.
10. Always keep your back straight when using the exercise cycle; do not arch your back.
11. If you feel pain or dizziness while exercising, stop immediately and cool down.
12. The exercise cycle does not have a free-wheel; the pedals will continue to move until the flywheel stops.
13. The decal shown on page 3 has been placed on the exercise cycle. If the decal is missing, or if it is not legible, please call toll-free 1-888-533-1333 and order a free replacement decal. Apply the decal in the location shown.

⚠ WARNING: Before beginning this or any exercise program, consult your physician. This is especially important for persons over the age of 35 or persons with pre-existing health problems. Read all instructions before using. Sears assumes no responsibility for personal injury or property damage sustained by or through the use of this product.

BEFORE YOU BEGIN

Congratulations on selecting the new PROFORM® XP 90 exercise cycle. Cycling is an effective exercise for increasing cardiovascular fitness, building endurance, and toning the entire body. The PROFORM XP 90 exercise cycle offers an impressive array of features that allow you to enjoy this healthful exercise in the convenience and privacy of your home.

For your benefit, read this manual carefully before you use the exercise cycle. If you have questions

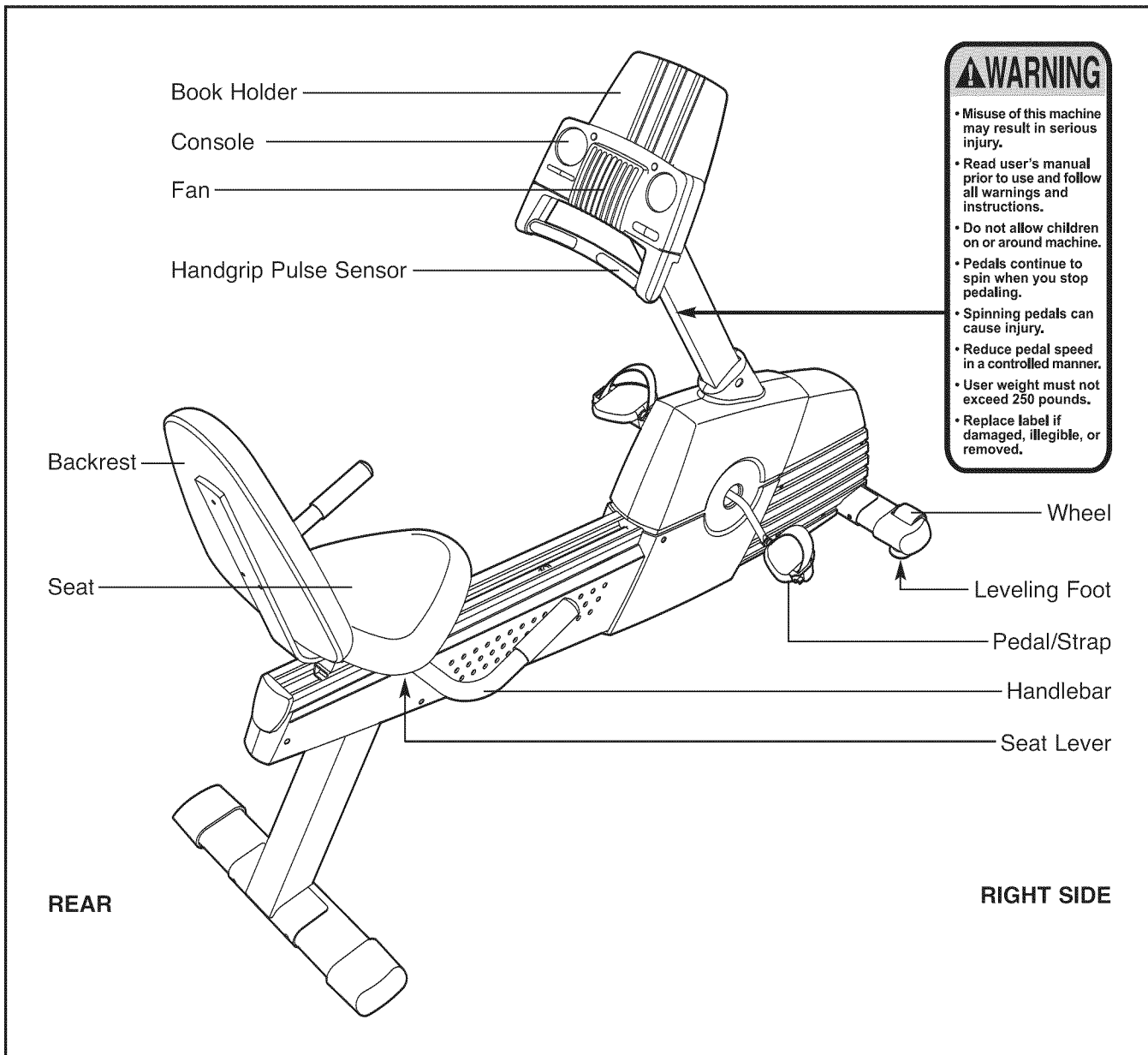

after reading this manual, please call 1-800-4-MY-HOME® (1-800-469-4663). To help us assist you, please note the product model number and serial number before calling. The model number is 831.21522.1. The serial number can be found on a decal attached to the exercise cycle (see the front cover of this manual).

Before reading further, please familiarize yourself with the parts labeled in the drawing below.



ASSEMBLY

Assembly requires two persons. Place all parts of the exercise cycle in a cleared area and remove the packing materials. Do not dispose of the packing materials until assembly is completed.

Assembly requires the included tools and your own adjustable wrench  **and Phillips screwdriver** .

Use the drawings below to identify the small parts used for assembly. The number in parentheses below each drawing is the key number of the part, from the PART LIST on page 21. The number following the key number is the quantity needed for assembly. **Note: Some small parts may have been pre-assembled. If a part is not in the parts bag, check to see if it has been pre-assembled. If a part is missing, call toll-free 1-888-533-1333.**

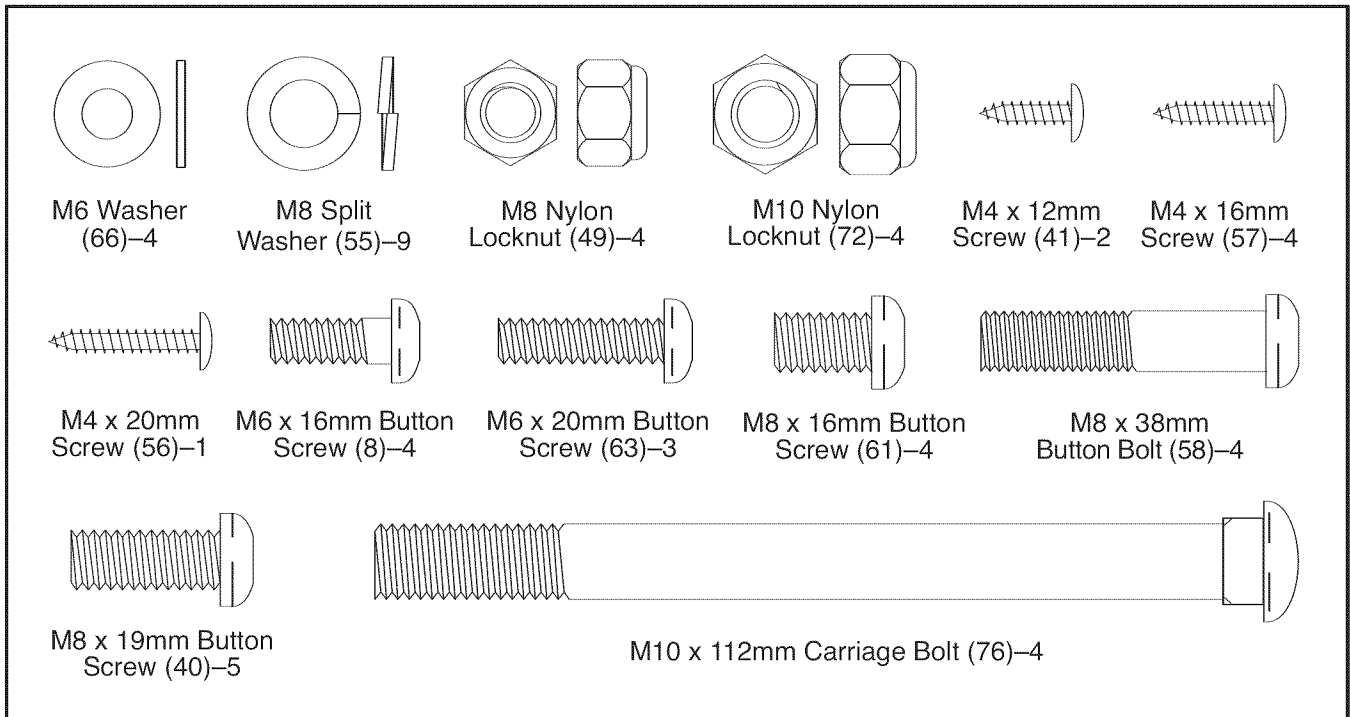

1. Orient the Rear Stabilizer (16) as shown. While another person lifts the Frame Rail (52), attach the Rear Stabilizer to the Frame Rail with two M10 x 112mm Carriage Bolts (76) and two M10 Nylon Locknuts (72).

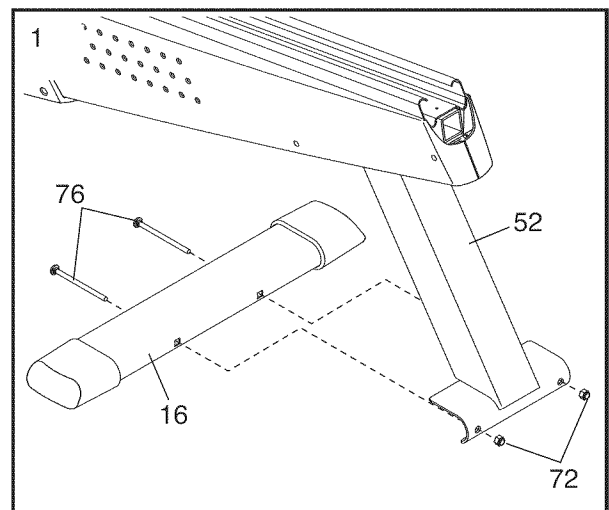

2. Orient the Front Stabilizer (15) as shown. While another person lifts the front of the Frame (1), attach the Front Stabilizer to the Frame with two M10 x 112mm Carriage Bolts (76) and two M10 Nylon Locknuts (72).

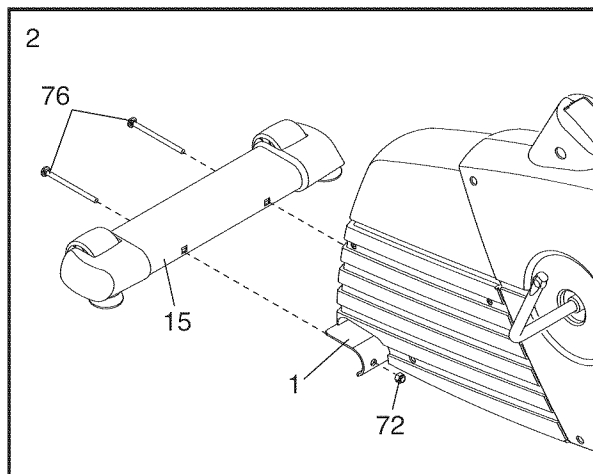

3. Attach the Frame Rail (52) to the Frame (1) with two M8 x 19mm Button Screws (40) and two M8 Split Washers (55). **Be careful to avoid damaging the Side Shields (26, 27).**

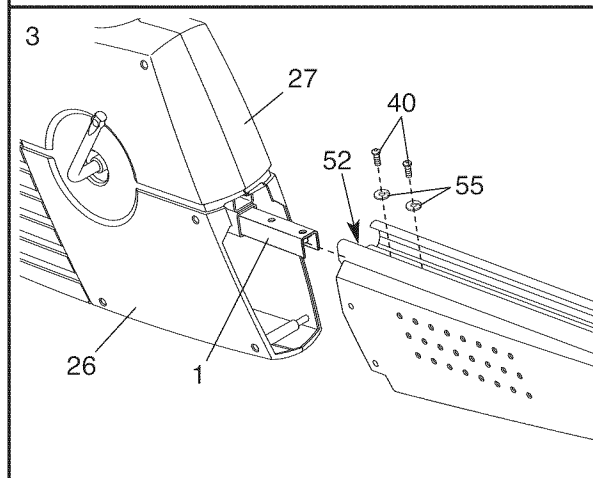

4. While another person holds the Upright (2) in the position shown, connect the Upper Wire Harness (42) to the Lower Wire Harness (43). Gently pull the upper end of the Upper Wire Harness to remove any slack from the Wire Harnesses.

Slide the Upright (2) onto the Frame (1) as shown. Attach the Upright with three M8 x 19mm Button Screws (40) and three M8 Split Washers (55). **Be careful to avoid pinching the Wire Harnesses (42, 43).**

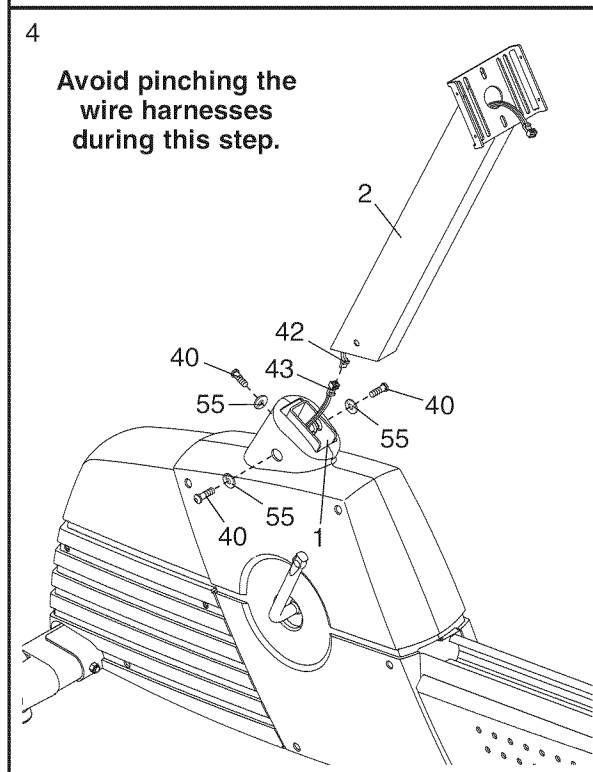

5. Orient the Seat Carriage Assembly (10) as shown. Attach the Seat Carriage Assembly to the Seat Bracket (11) with four M8 x 16mm Button Screws (61) and four M8 Split Washers (55).

Attach a Handlebar (3) to the Seat Bracket (11) with two M8 x 38mm Button Bolts (58) and two M8 Nylon Locknuts (49). **Make sure that the Nylon Locknuts are resting in the hexagonal holes in the front of the Handlebar.**

Attach the other Handlebar (3) to the Seat Bracket (11) in the same way.

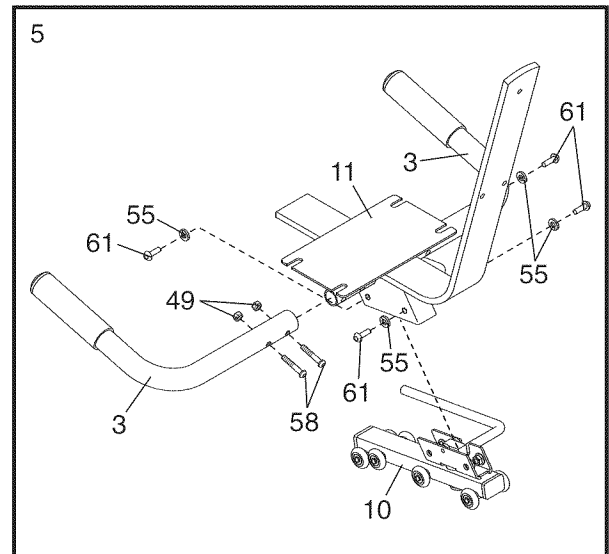

6. Attach the Seat (9) to the Seat Bracket (11) with four M6 x 16mm Button Screws (8) and four M6 Washers (66).

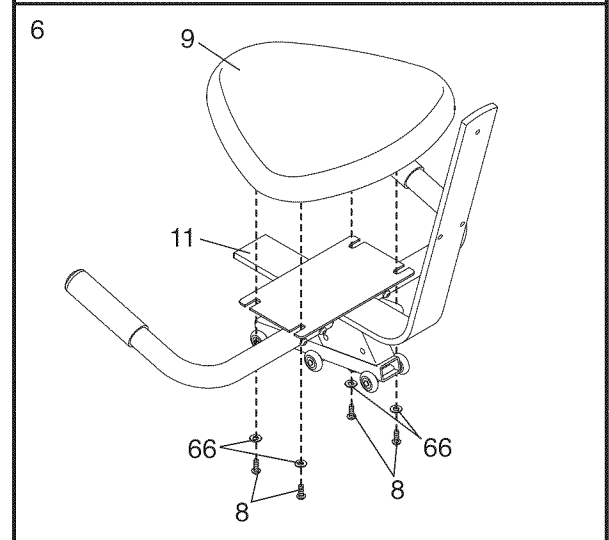

7. Attach the Backrest (31) to the Seat Bracket (11) with three M6 x 20mm Button Screws (63).

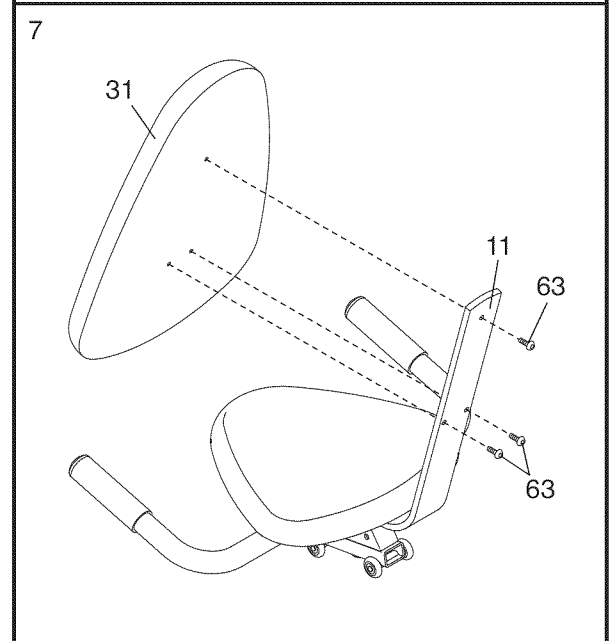

8. Push down the seat lever (not shown) on the right side of the Seat Carriage Assembly (10), slide the Seat Carriage Assembly into the Seat Rail (78), and then pull the seat lever back up.

Attach a Bumper (51) to the Seat Rail (78) with an M4 x 20mm Screw (56). Next, press the Frame Rail Endcap (50) into the end of the Frame Rail (52).

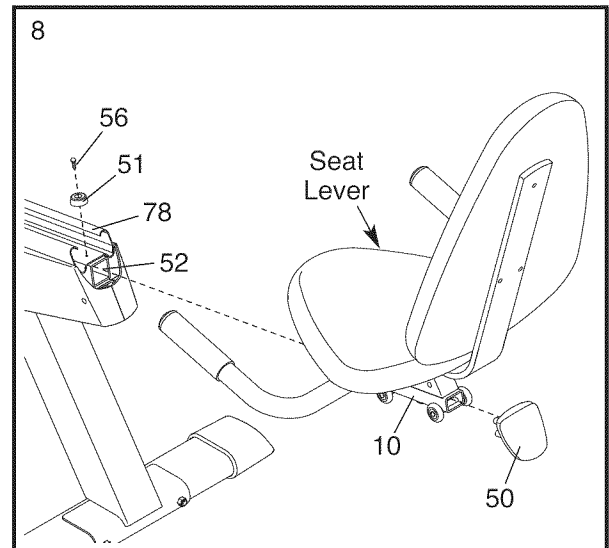

9. The Console (4) requires four 1.5V "D" batteries (not included); alkaline batteries are recommended. Remove the two battery covers from the Console. Next, insert four batteries into the battery compartments. **Make sure that the batteries are oriented as shown by the diagrams inside of the battery compartments.** Then, reattach the battery covers to the Console.

Attach the Book Holder (23) to the Console (4) with two M4 x 12mm Screws (41) as shown.

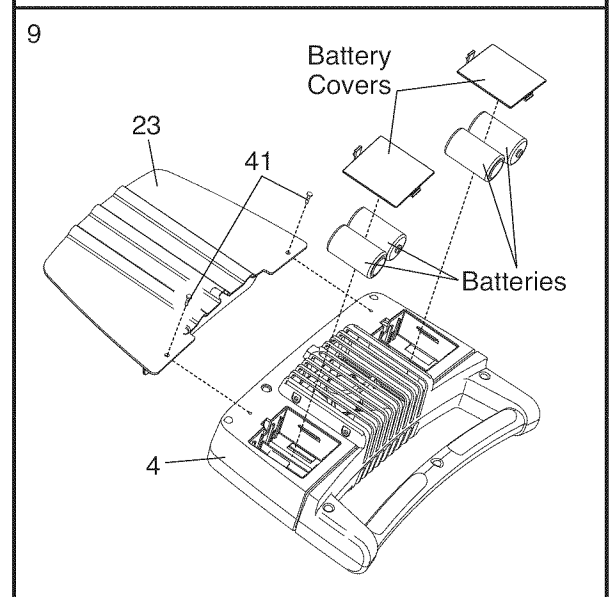

10. While another person holds the Console (4) in the position shown, connect the wire harness on the Console to the Upper Wire Harness (42). Insert the excess wire harness down into the Upright (2).

Attach the Console (4) to the Upright (2) with four M4 x 16mm Screws (57) and two Console Brackets (80). **Be careful to avoid pinching the wire harnesses.**

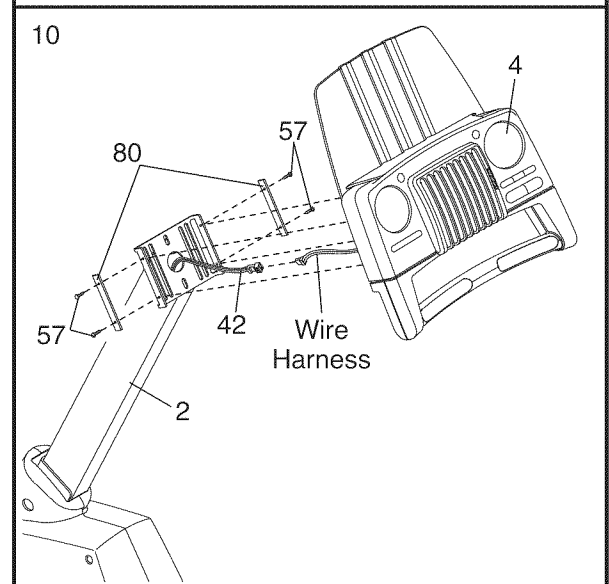

11. Identify the Left Pedal (22), which is marked with an "L." Using an adjustable wrench, **firmly tighten** the Left Pedal *counterclockwise* into the left arm on the Crank (29). Tighten the Right Pedal (not shown) *clockwise* into the right arm on the Crank. **Important: Tighten both Pedals as firmly as possible. After using the exercise cycle for one week, retighten the Pedals. For best performance, the Pedals must be kept tightened.**

Adjust the Left Pedal Strap (25) to the desired position, and press the end of the Left Pedal Strap onto the tab on the Left Pedal (22).

Adjust the Right Pedal Strap (not shown) in the same way.

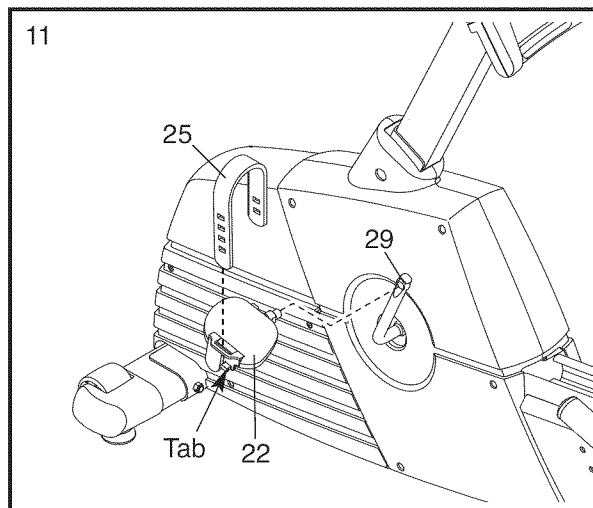

12. **Make sure that all parts are properly tightened before you use the exercise cycle.** Note: After assembly is completed, some extra parts may be left over. Place a mat beneath the exercise cycle to protect the floor.

HOW TO OPERATE THE EXERCISE CYCLE

HOW TO ADJUST THE SEAT

For effective exercise, the seat should be in the proper position. As you pedal, there should be a slight bend in your knees when you extend the pedals all the way forward. To adjust the seat, push the seat lever down, slide the seat forward or backward, and then firmly pull the seat lever up.

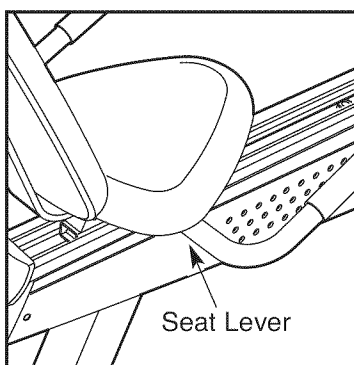

HOW TO ADJUST THE PEDAL STRAPS

To adjust the pedal straps, first pull the ends of the straps off the tabs on the pedals. Adjust the straps to the desired position, and then press the ends of the straps back onto the tabs.

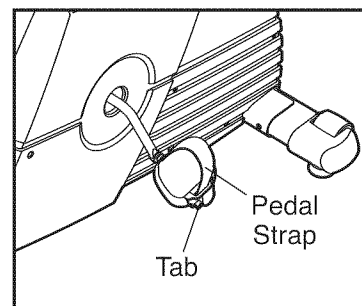

CONSOLE DIAGRAM

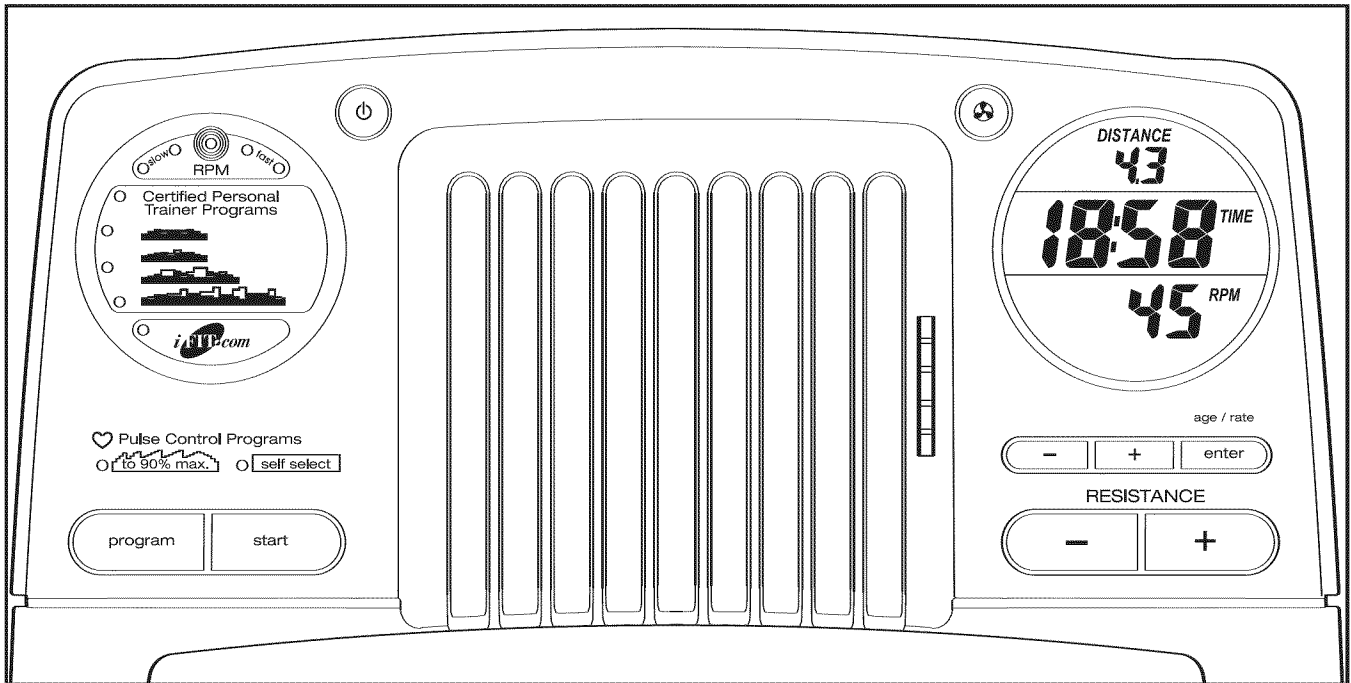

FEATURES OF THE CONSOLE

The advanced console offers a selection of features designed to make your workouts more enjoyable and effective. When you select the manual mode of the console, you can change the resistance of the pedals with the touch of a button. As you pedal, the console will provide continuous exercise feedback. You can even measure your heart rate using the built-in hand-grip pulse sensor.

The console also offers four preset programs. Each program automatically changes the resistance of the pedals and prompts you to increase or decrease your pace as it guides you through an effective workout.

In addition, the console features two pulse programs that change the resistance of the pedals to keep your heart rate near a target heart rate while you exercise.

The console also features iFIT.com interactive technology. Having iFIT.com technology is like having a personal trainer in your home. Using a stereo audio cable

(available at electronics stores), you can connect the exercise cycle to your home stereo, portable stereo, computer, or VCR and play special iFIT.com CD and video programs (iFIT.com CDs and videocassettes are available separately). iFIT.com CD and video programs automatically control the resistance of the pedals and prompt you to vary your pace as a personal trainer coaches you through every step of your workout. High-energy music provides added motivation. **To purchase iFIT.com CDs and videocassettes, call toll-free 1-888-533-1333.**

With the exercise cycle connected to your computer, you can also go to our Web site at www.iFIT.com and access programs directly from the internet. **Explore www.iFIT.com for more information.**

To use the manual mode of the console, see page 10. To use a preset program, see page 12. To use a pulse program, see page 12. To use an iFIT.com CD or video program, see page 17. To use a program directly from our Web site, see page 18.

HOW TO USE THE MANUAL MODE

1 Turn on the console.

To turn on the console, press the On/Reset button or begin pedaling. Note: If there are sheets of clear plastic on the face of the console, remove the plastic.

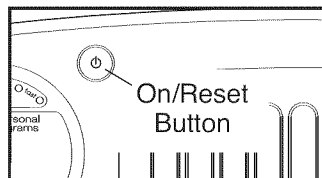

2 Select the manual mode.

When the power is turned on, the manual mode will be selected. If you have selected a program or the iFIT.com mode, reselect the manual mode by pressing the Program button repeatedly until no indicators are lit.



3 Begin pedaling, and change the resistance of the pedals as desired.

As you pedal, change the resistance of the pedals by pressing the Resistance buttons. There are ten resistance levels—level 10 is the most challenging. Note: After you press the buttons, it will take a moment for the pedals to reach the selected resistance level.



4 Monitor your progress with the display.

The upper part of the display will show the distance you have pedaled and the approximate number of calories you have burned. The display will change from one number to the other every few seconds. The upper part of the display will also show your heart rate when you use the handgrip pulse sensor (see step 5 on page 11).

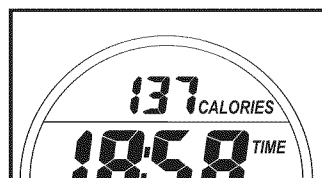

The center of the display will show the elapsed time, your pedaling pace in minutes per mile, and the approximate number of grams of carbs you have burned. The display will change from one number to the next every few seconds. Note: When a program is selected (except for the self select program), the display will show the time remaining in the program instead of the elapsed time.

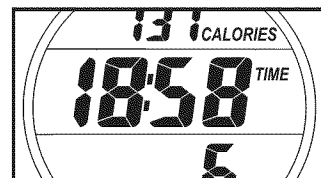

The lower part of the display will show your pedaling pace in revolutions per minute (RPM), your pedaling speed, and the resistance level of the pedals. The display will change from one number to the next every few seconds.



To reset the display, press the On/Reset button.

Note: The console can show speed and distance in either miles or kilometers. The letters MPH or KM/H will appear in

the lower part of the display to indicate which unit of measurement is selected. To change the unit of measurement, first hold down the Program button for a few seconds. An E (for English) or an M (for metric) will appear in the lower part of the display. Press the Resistance + button to change the unit of measurement. Note: When you replace the batteries, you may have to reselect the desired unit of measurement.



While you are selecting a unit of measurement, you can also select a backlight mode.

The "On" mode keeps the backlight on while the console is on. The "Off" mode turns the backlight off. To conserve the batteries, the "Auto" mode keeps the backlight on only while you are exercising. Press the Resistance – button to change the backlight mode if you desire. Then, press the On/Reset button.

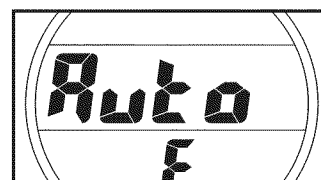

5 Measure your heart rate if desired.

If there are thin sheets of plastic on the metal contacts on the handgrip pulse sensor, peel off the plastic. Place your hands on

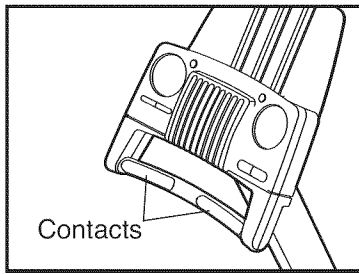

the handgrip pulse sensor, with your palms on the contacts closest to you and your fingers touching the contacts on the opposite side of the handgrip pulse sensor. **Avoid moving your hands.** When your pulse is detected, the heart-shaped indicator in the upper part of the display will begin to flash each time your heart beats. After a moment, the display will show your heart rate.

For the most accurate heart rate reading, continue to hold the handgrips for about 30 seconds.

Note: If you continue to hold the handgrip pulse sensor, the display will show your heart rate for up to 30 seconds. The display will then show your heart rate along with the other modes.

If your heart rate is not shown, make sure that your hands are positioned as described. Avoid moving your hands excessively or squeezing the metal contacts too tightly. For optimal performance, periodically clean the metal contacts using a soft cloth; **never use alcohol, abrasives, or chemicals to clean the contacts.**

6 Turn on the fan if desired.

To turn on the fan at low speed, press the fan button. To turn on the fan at high speed, press the fan button a second time. To turn off the fan, press the fan button a third time. Note:

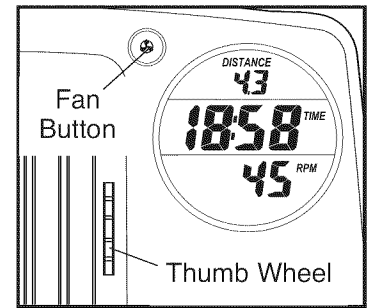

If the fan is turned on but the pedals are not moved for thirty seconds, the fan will automatically turn off.

Rotate the thumb wheel on the right side of the fan to adjust the angle of the fan.

7 When you are finished exercising, the console will automatically turn off.

If the pedals are not moved for a few seconds, a series of tones will sound, the time will begin to flash, and the console will pause.

If the pedals are not moved for a few minutes, the console will turn off and the display will be reset.

HOW TO USE A PRESET PROGRAM

1 Turn on the console.

See step 1 on page 10.

2 Select one of the preset programs.

To select a preset program, press the Program button repeatedly until one of the four preset program indicators lights.



3 Press the Start button or begin pedaling to start the program.

Each preset program consists of several one-minute periods. One resistance setting and one target pace are programmed for each period. Note: The same resistance setting and/or target pace may be programmed for two or more consecutive periods, as shown by the four profiles near the program indicators.

At the end of each period of the program, a series of tones will sound and the time will flash in the display. The resistance of the pedals will then automatically change if a different resistance setting is programmed for the next period. Note: If the resistance level is too high or too low, you can change it manually by pressing the Resistance buttons. However, when the current period ends, the pedal resistance will automatically change if a different resistance setting is programmed for the next period.

During the program, the center of the display will show the time remaining in the program. If you stop pedaling for several seconds, the program will pause and the time will flash in the display. To restart the program, simply resume pedaling.

4 Use the pace guide to pace your exercise.

Throughout the program, the pace guide located above the program indicators will prompt you to increase or decrease your pedaling pace.

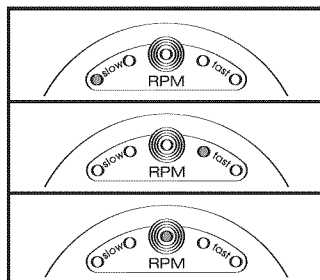

When one of the indicators on the left side of the pace guide lights, increase your pace; when one of the indicators on the right side lights, decrease your pace. When the center indicator lights, maintain your current pace. **Important: The pace guide is intended only to provide a goal. Make sure to pedal at a pace that is comfortable for you.**

5 Monitor your progress with the display.

See step 4 on page 10.

6 Measure your heart rate if desired.

See step 5 on page 11.

7 Turn on the fan if desired.

See step 6 on page 11.

8 When you are finished exercising, the console will automatically turn off.

See step 7 on page 11.

HOW TO USE A PULSE PROGRAM

Pulse program 1 is designed to keep your heart rate between 65% and 90% of your *estimated maximum heart rate* during your workout. (Your maximum heart rate is estimated by subtracting your age from 220. For example, if you are 25 years old, your estimated maximum heart rate is 195 beats per minute.) Pulse program 2 is designed to keep your heart rate near a target heart rate that you select.

Follow the steps below to use a pulse program.

1 Turn on the console.

See step 1 on page 10.

2 Select one of the pulse programs.

To select a pulse program, press the Program button repeatedly until one of the two pulse program indicators lights.

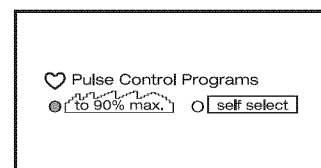

3 Enter your age or a target heart rate.

If pulse program 1 is selected, the word "AGE" will flash in the lower part of the display.

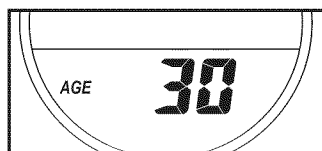

You must enter your age to use this program. If you have already entered your age, press the Enter button and go to step 4. If you have not entered your age, press the + or – button beside the Enter button to enter your age, and then press the Enter button. Note: Once you have entered your age, it will be saved in memory.

If pulse program 2 is selected, the word "RATE" will flash in the lower part of the display.

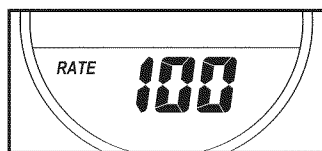

You must enter a target heart rate to use this program. (See the chart on page 20 for heart rate guidelines.) If you have already entered a target heart rate, press the Enter button and go to step 4. If you have not entered a target heart rate, press the + or – button beside the Enter button to enter a target heart rate, and then press the Enter button. Note: Once you have entered a target heart rate, it will be saved in memory.

4 Hold the handgrip pulse sensor.

It is not necessary to hold the handgrips continuously during a pulse program; however, you must hold the handgrips frequently for the program to operate properly. **Each time you hold the handgrips, keep your hands on the metal contacts for at least 30 seconds.** Note: When you are not holding the handgrips, the letters PLS will appear in the upper part of the display instead of your heart rate.

5 Press the Start button or begin pedaling to start the program.

Program 1 consists of 30 one-minute periods. One target heart rate is programmed for each

period. (The same target heart rate may be programmed for two or more consecutive periods.) **Program 2** is sixty minutes long (you may choose to use only part of the program). The same target heart rate is programmed for the entire program.

When only three seconds remain in the first period of the program, a series of tones will sound and the time will flash in the display.

During the program, the console will regularly compare your heart rate to the target heart rate. If your heart rate is too far below or above the target heart rate, the resistance of the pedals will automatically increase or decrease to bring your heart rate closer to the target heart rate. Note: If the resistance level is too high or too low, you can change it manually by pressing the Resistance buttons. However, when the console compares your heart rate to the target heart rate, the resistance may automatically change.

The program will continue until no time remains in the display. If you stop pedaling for several seconds, the program will pause and the time will flash in the display. To restart the program, simply resume pedaling.

6 Monitor your progress with the display.

See step 4 on page 10.

7 Turn on the fan if desired.

See step 6 on page 11.

8 When you are finished exercising, the console will automatically turn off.

See step 7 on page 11.

HOW TO CONNECT YOUR CD PLAYER, VCR, OR COMPUTER

To use **iFIT.com CDs**, the exercise cycle must be connected to your portable CD player, portable stereo, home stereo, or computer with CD player. See pages 14 and 15 for connecting instructions. To use **iFIT.com videocassettes**, the exercise cycle must be connected to your VCR. See page 16 for connecting instructions. To use **iFIT.com programs directly from our Web site**, the exercise cycle must be connected to your home computer. See page 15 for connecting instructions.

HOW TO CONNECT YOUR PORTABLE CD PLAYER

Note: If your CD player has separate **LINE OUT** and **PHONES** jacks, see instruction A below. If your CD player has only one jack, see instruction B.

- A. Plug one end of a 1/8" to 1/8" stereo audio cable (available at electronics stores) into the jack beneath the console. Plug the other end of the cable into the **LINE OUT** jack on your CD player. Plug your headphones into the **PHONES** jack.

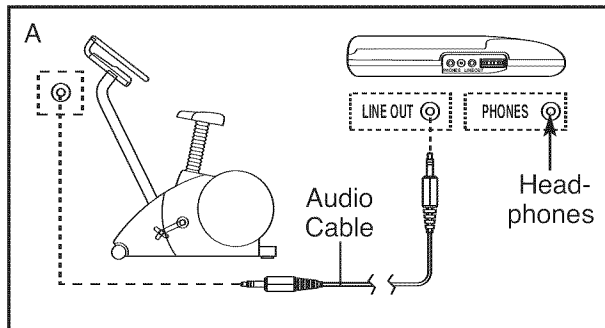

- B. Plug one end of a 1/8" to 1/8" stereo audio cable (available at electronics stores) into the jack beneath the console. Plug the other end of the cable into a 1/8" Y-adapter (available at electronics stores). Plug the Y-adapter into the **PHONES** jack on your CD player. Plug your headphones into the other side of the Y-adapter.

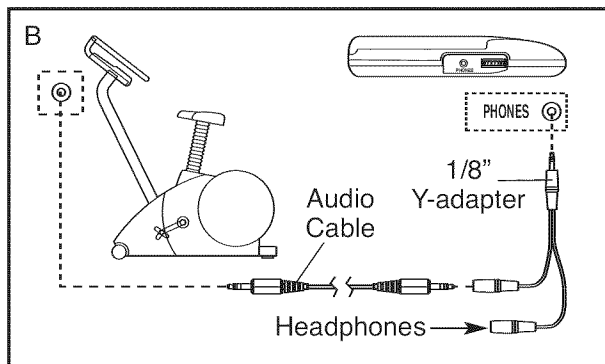

HOW TO CONNECT YOUR PORTABLE STEREO

Note: If your stereo has an **RCA-type AUDIO OUT** jack, see instruction A below. If your stereo has a 1/8" **LINE OUT** jack, see instruction B. If your stereo has only a **PHONES** jack, see instruction C.

- A. Plug one end of a 1/8" to RCA stereo audio cable (available at electronics stores) into the jack beneath the console. Plug the other end of the cable into the **AUDIO OUT** jack on your stereo.

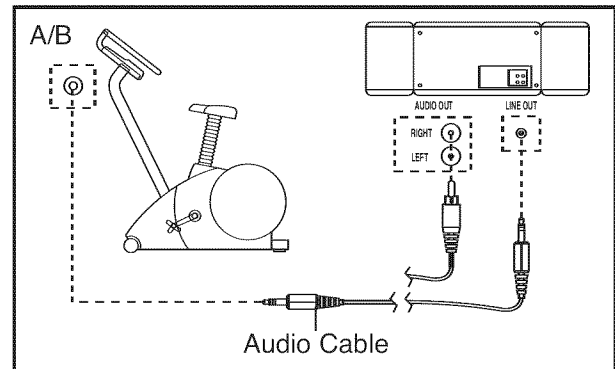

- B. See the drawing above. Plug one end of a 1/8" to 1/8" stereo audio cable (available at electronics stores) into the jack beneath the console. Plug the other end of the cable into the **LINE OUT** jack on your stereo.

- C. Plug one end of a 1/8" to 1/8" stereo audio cable (available at electronics stores) into the jack beneath the console. Plug the other end of the cable into a 1/8" Y-adapter (available at electronics stores). Plug the Y-adapter into the **PHONES** jack on your stereo. Plug your headphones into the other side of the Y-adapter.

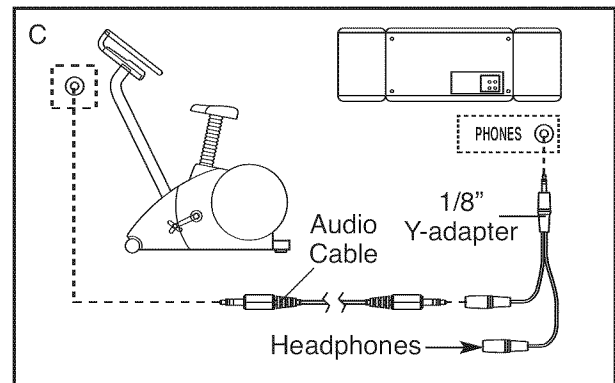

HOW TO CONNECT YOUR HOME STEREO

Note: If your stereo has an unused **LINE OUT** jack, see instruction **A** below. If the **LINE OUT** jack is being used, see instruction **B**.

- A. Plug one end of a 1/8" to RCA stereo audio cable (available at electronics stores) into the jack beneath the console. Plug the other end of the cable into the **LINE OUT** jack on your stereo.

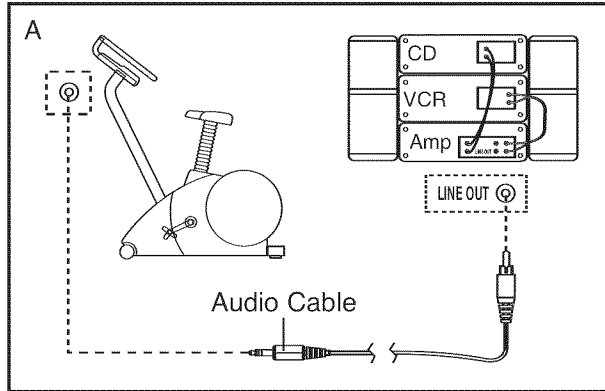

- B. Plug one end of a 1/8" to RCA stereo audio cable (available at electronics stores) into the jack beneath the console. Plug the other end of the cable into an RCA Y-adapter (available at electronics stores). Next, remove the wire that is currently plugged into the **LINE OUT** jack on your stereo and plug the wire into the unused side of the Y-adapter. Plug the Y-adapter into the **LINE OUT** jack on your stereo.

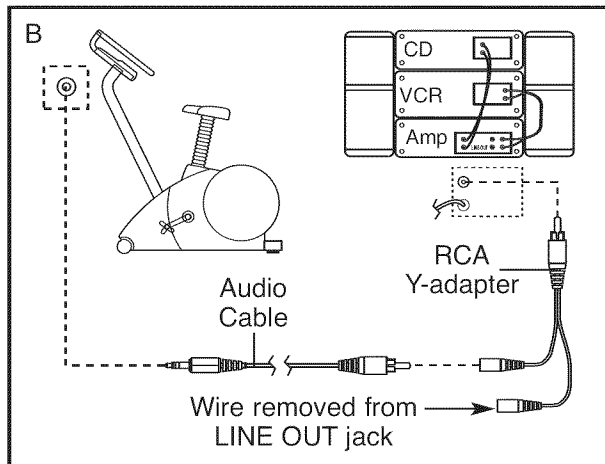

HOW TO CONNECT YOUR COMPUTER

Note: If your computer has a 1/8" **LINE OUT** jack, see instruction **A**. If your computer has only a **PHONES** jack, see instruction **B**.

- A. Plug one end of a 1/8" to 1/8" stereo audio cable (available at electronics stores) into the jack beneath the console. Plug the other end of the cable into the **LINE OUT** jack on your computer.

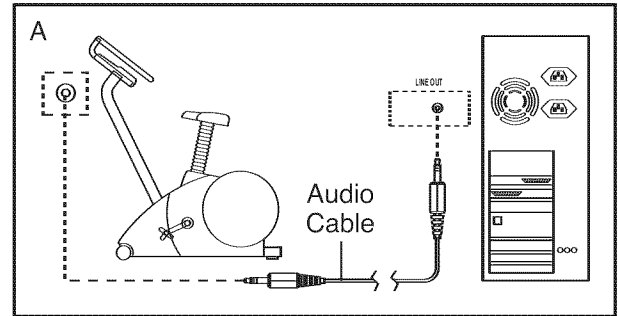

- B. Plug one end of a 1/8" to 1/8" stereo audio cable (available at electronics stores) into the jack beneath the console. Plug the other end of the cable into a 1/8" Y-adapter (available at electronics stores). Plug the Y-adapter into the **PHONES** jack on your computer. Plug your headphones or speakers into the other side of the Y-adapter.

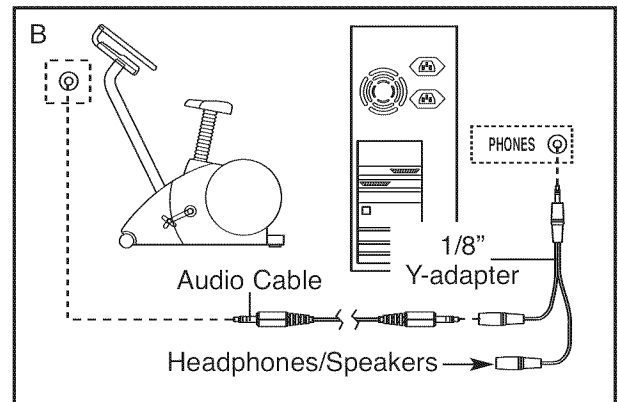

HOW TO CONNECT YOUR VCR

Note: If your VCR has an unused AUDIO OUT jack, see instruction A below. If the AUDIO OUT jack is being used, see instruction B. If you have a TV with a built-in VCR, see instruction B. If your VCR is connected to your home stereo, see HOW TO CONNECT YOUR HOME STEREO on page 15.

- A. Plug one end of a 1/8" to RCA stereo audio cable (available at electronics stores) into the jack beneath the console. Plug the other end of the cable into the AUDIO OUT jack on your VCR.

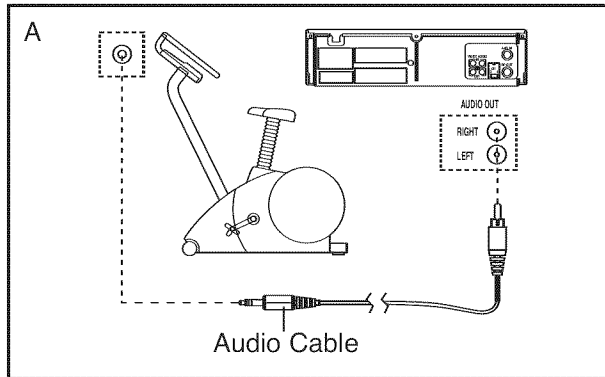

- B. Plug one end of a 1/8" to RCA stereo audio cable (available at electronics stores) into the jack beneath the console. Plug the other end of the cable into an RCA Y-adapter (available at electronics stores). Next, remove the wire that is currently plugged into the AUDIO OUT jack on your VCR and plug the wire into the unused side of the Y-adapter. Plug the Y-adapter into the AUDIO OUT jack on your VCR.

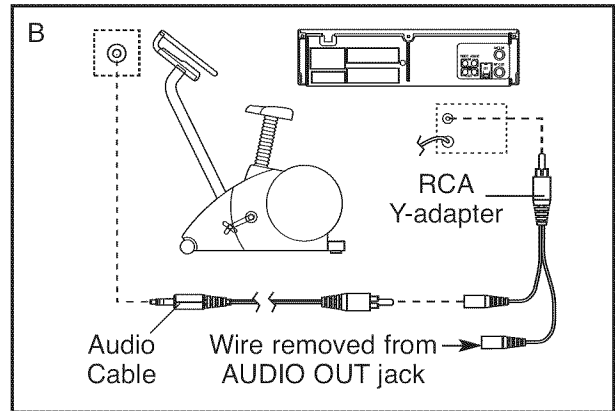

HOW TO USE AN iFIT.COM CD OR VIDEO PROGRAM

To use iFIT.com CDs or videocassettes, the exercise cycle must be connected to your portable CD player, portable stereo, home stereo, computer with CD player, or VCR. See HOW TO CONNECT YOUR CD PLAYER, VCR, OR COMPUTER on pages 14 to 16. **To purchase iFIT.com CDs and videocassettes, call toll-free 1-888-533-1333.**

Follow the steps below to use an iFIT.com CD or video program.

1 Turn on the console.

See step 1 on page 10.

2 Select the iFIT.com mode.

To select the iFIT.com mode, press the Program button repeatedly until the iFIT.com indicator lights.

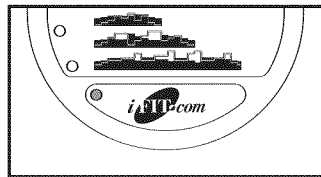

3 Insert the iFIT.com CD or videocassette.

If you are using an iFIT.com CD, insert the CD into your CD player. If you are using an iFIT.com videocassette, insert the videocassette into your VCR.

4 Press the play button on your CD player or VCR.

A moment after the play button is pressed, your personal trainer will begin guiding you through

your workout. Simply follow your personal trainer's instructions.

The program will function in almost the same way as a preset program (see steps 3 and 4 on page 12). However, an electronic "chirping" sound will alert you when the resistance of the pedals and/or the pace guide is about to change.

Note: If the pedal resistance and/or the pace guide does not change when a "chirp" sounds:

- Make sure that the iFIT.com indicator is lit.
- Adjust the volume of your CD player or VCR. If the volume is too high or too low, the console may not detect the program signals.
- Make sure that the audio cable is properly connected and that it is fully plugged in.

5 Monitor your progress with the display.

See step 4 on page 10.

6 Measure your heart rate if desired.

See step 5 on page 11.

7 Turn on the fan if desired.

See step 6 on page 11.

8 When you are finished exercising, the console will automatically turn off.

See step 7 on page 11.

HOW TO USE PROGRAMS DIRECTLY FROM OUR WEB SITE

Our Web site at www.iFIT.com allows you to play iFIT.com programs directly from the internet. To use programs from our Web site, the exercise cycle must be connected to your home computer. See **HOW TO CONNECT YOUR COMPUTER** on page 15. In addition, you must have an internet connection and an internet service provider. A list of specific system requirements is found on our Web site.

Follow the steps below to use a program from our Web site.

1 Turn on the console.

See step 1 on page 10.

2 Select the iFIT.com mode.

To select the iFIT.com mode, press the Program button repeatedly until the iFIT.com indicator lights.

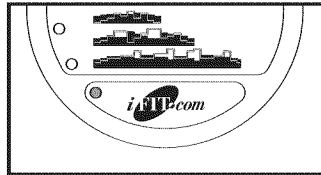

3 Go to your computer and start an internet connection.

4 Start your Web browser, if necessary, and go to our Web site at www.iFIT.com.

5 Follow the desired links on our Web site to select a program.

Read and follow the online instructions for using a program.

6 Follow the online instructions to start the program.

When you start the program, an on-screen countdown will begin.

7 Return to the exercise cycle and begin pedaling.

When the on-screen countdown ends, the program will begin. The program will function in almost the same way as a preset program (see steps 3 and 4 on page 12). However, an electronic “chirping” sound will alert you when the pedal resistance and/or the pace guide is about to change.

8 Monitor your progress with the display.

See step 4 on page 10.

9 Measure your heart rate if desired.

See step 5 on page 11.

10 Turn on the fan if desired.

See step 6 on page 11.

11 When you are finished exercising, the console will automatically turn off.

See step 7 on page 11.

MAINTENANCE AND TROUBLESHOOTING

Inspect and tighten all parts of the exercise cycle regularly. Replace any worn parts immediately.

To clean the exercise cycle, use a damp cloth and a small amount of mild soap. **Important: To avoid damaging the console, keep liquids away from the console and keep the console out of direct sunlight.**

HOW TO MOVE THE EXERCISE CYCLE

To move the exercise cycle, stand behind it and lift the frame in the location shown below. **To reduce the risk of injury, bend your legs and keep your back straight. As you lift the frame, make sure to lift with your legs rather than your back.** Carefully move the exercise cycle on the front wheels, and then lower the frame.

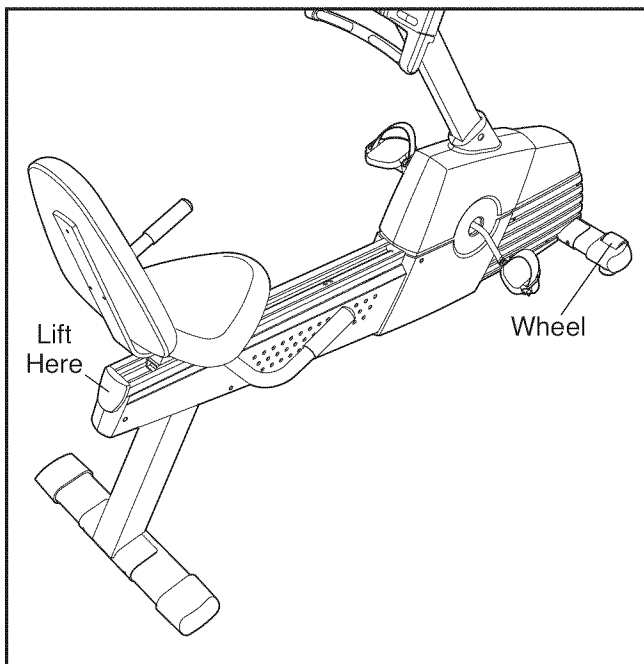

HOW TO LEVEL THE EXERCISE CYCLE

After the exercise cycle has been moved to the location where it will be used, make sure that both ends of front stabilizer are touching the floor.

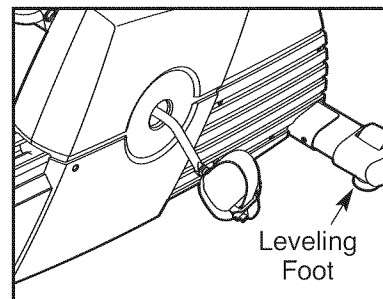

If the exercise cycle rocks slightly during use, turn one or both of the leveling feet under the front stabilizer until the rocking motion is eliminated.

HANDGRIP PULSE SENSOR TROUBLESHOOTING

- Avoid moving your hands while using the handgrip pulse sensor. Excessive movement may interfere with heart rate readings.
- Do not hold the metal contacts too tightly; doing so may interfere with heart rate readings.
- For the most accurate heart rate reading, hold the metal contacts for about 30 seconds.
- For optimal performance of the handgrip pulse sensor, keep the metal contacts clean. The contacts can be cleaned with a soft cloth; **never use alcohol, abrasives, or chemicals to clean the contacts.**

BATTERY REPLACEMENT

If the displays on the console become dim, the batteries should be replaced. Most console problems are the result of low batteries. See assembly step 9 on page 7 for battery replacement instructions.

CONDITIONING GUIDELINES

The following guidelines will help you to plan your exercise program. Remember that proper nutrition and adequate rest are essential for successful results.

⚠ WARNING: Before beginning this or any exercise program, consult your physician. This is especially important for persons over the age of 35 or persons with pre-existing health problems.

The pulse sensor is not a medical device. Various factors may affect the accuracy of heart rate readings. The pulse sensor is intended only as an exercise aid in determining heart rate trends in general.

EXERCISE INTENSITY

Whether your goal is to burn fat or to strengthen your cardiovascular system, the key to achieving the desired results is to exercise with the proper intensity. The proper intensity level can be found by using your heart rate as a guide. The chart below shows recommended heart rates for fat burning, maximum fat burning, and cardiovascular (aerobic) exercise.

165	155	145	140	130	125	115	♥
145	138	130	125	118	110	103	♥
125	120	115	110	105	95	90	♥
<hr/>							
20	30	40	50	60	70	80	

To find the proper heart rate for you, first find your age at the bottom of the chart (ages are rounded off to the nearest ten years). Next, find the three numbers above your age. The three numbers are your “training zone.” The lowest number is the recommended heart rate for fat burning; the middle number is the recommended heart rate for maximum fat burning; the highest number is the recommended heart rate for aerobic exercise.

Fat Burning

To burn fat effectively, you must exercise at a relatively low intensity level for a sustained period of time.

During the first few minutes of exercise, your body uses easily accessible *carbohydrate* calories for energy. Only after the first few minutes of exercise does your body begin to use stored *fat* calories for energy. If your goal is to burn fat, adjust the intensity of your exercise until your heart rate is near the lowest number in your training zone as you exercise. For maximum fat burning, adjust the intensity of your exercise until your heart rate is near the middle number in your training zone as you exercise.

Aerobic Exercise

If your goal is to strengthen your cardiovascular system, your exercise must be “aerobic.” Aerobic exercise is activity that requires large amounts of oxygen for prolonged periods of time. This increases the demand on the heart to pump blood to the muscles, and on the lungs to oxygenate the blood. For aerobic exercise, adjust the intensity of your exercise until your heart rate is near the highest number in your training zone.

WORKOUT GUIDELINES

Each workout should include the following three parts:

A warm-up, consisting of 5 to 10 minutes of stretching and light exercise. A proper warm-up increases your body temperature, heart rate, and circulation in preparation for exercise.

Training zone exercise, consisting of 20 to 30 minutes of exercising with your heart rate in your training zone. Note: During the first few weeks of your exercise program, do not keep your heart rate in your training zone for longer than 20 minutes.

A cool-down, with 5 to 10 minutes of stretching. This will increase the flexibility of your muscles and will help to prevent post-exercise problems.

EXERCISE FREQUENCY

To maintain or improve your condition, plan three workouts each week, with at least one day of rest between workouts. After a few months of regular exercise, you may complete up to five workouts each week, if desired. Remember, the key to success is make exercise a regular and enjoyable part of your everyday life.

PART LIST—Model No. 831.21522.1

R0406A

Key No.	Qty.	Description	Key No.	Qty.	Description
1	1	Frame	42	1	Upper Wire Harness
2	1	Upright	43	1	Lower Wire Harness
3	2	Handlebar	44	1	Left Rail Cover
4	1	Console	45	1	Clamp
5	1	“C” Magnet Bracket	46	1	Reed Switch/Wire
6	1	Flywheel Axle	47	1	Drive Belt
7	2	M6 Nut	48	1	Flywheel Cover
8	6	M6 x 16mm Button Screw	49	6	M8 Nylon Locknut
9	1	Seat	50	1	Frame Rail Endcap
10	1	Seat Carriage Assembly	51	2	Bumper
11	1	Seat Bracket	52	1	Frame Rail
12	1	Left Front Endcap	53	1	Right Belt Cover
13	1	Right Front Endcap	54	1	Left Belt Cover
14	2	Rear Stabilizer Endcap	55	9	M8 Split Washer
15	1	Front Stabilizer	56	2	M4 x 20mm Screw
16	1	Rear Stabilizer	57	14	M4 x 16mm Screw
17	2	Wheel	58	4	M8 x 38mm Button Bolt
18	1	Right Pedal Strap	59	4	M4 Washer
19	2	Leveling Foot	60	4	M4 x 25mm Screw
20	2	Seat Carriage Endcap	61	4	M8 x 16mm Button Screw
21	1	Right Pedal	62	6	M4 x 10mm Screw
22	1	Left Pedal	63	3	M6 x 20mm Button Screw
23	1	Book Holder	64	8	Small Snap Ring
24	2	Handlebar Endcap	65	8	Carriage Wheel
25	1	Left Pedal Strap	66	5	M6 Washer
26	1	Left Side Shield	67	7	M4 x 38mm Screw
27	1	Right Side Shield	68	4	M4 x 15mm Flange Bolt
28	2	Foam Grip	69	2	Eyebolt
29	1	Crank/Pulley	70	2	Flywheel Bearing
30	1	Magnet	71	4	M4 Nylon Locknut
31	1	Backrest	72	4	M10 Nylon Locknut
32	2	Flywheel Washer	73	1	Flywheel Bracket
33	1	Crank Bearing Set	74	4	M6 Nylon Locknut
34	1	Flywheel	75	2	M6 x72mm Button Screw
35	1	“C” Magnet	76	4	M10 x 112mm Carriage Bolt
36	1	Resistance Cable Assembly	77	1	Stop Bolt
37	1	Spring	78	1	Seat Rail
38	1	Resistance Motor	79	6	M6 x 16mm Screw
39	1	Right Rail Cover	80	2	Console Bracket
40	5	M8 x 19mm Button Screw	#	1	Hex Key
41	4	M4 x 12mm Screw	#	1	User’s Manual

Note: “#” indicates a non-illustrated part. Specifications are subject to change without notice. **If a part is missing, call toll-free 1-888-533-1333.** See the back cover of this manual for information about ordering replacement parts.

EXPLODED DRAWING A—Model No. 831.21522.1

R0406A

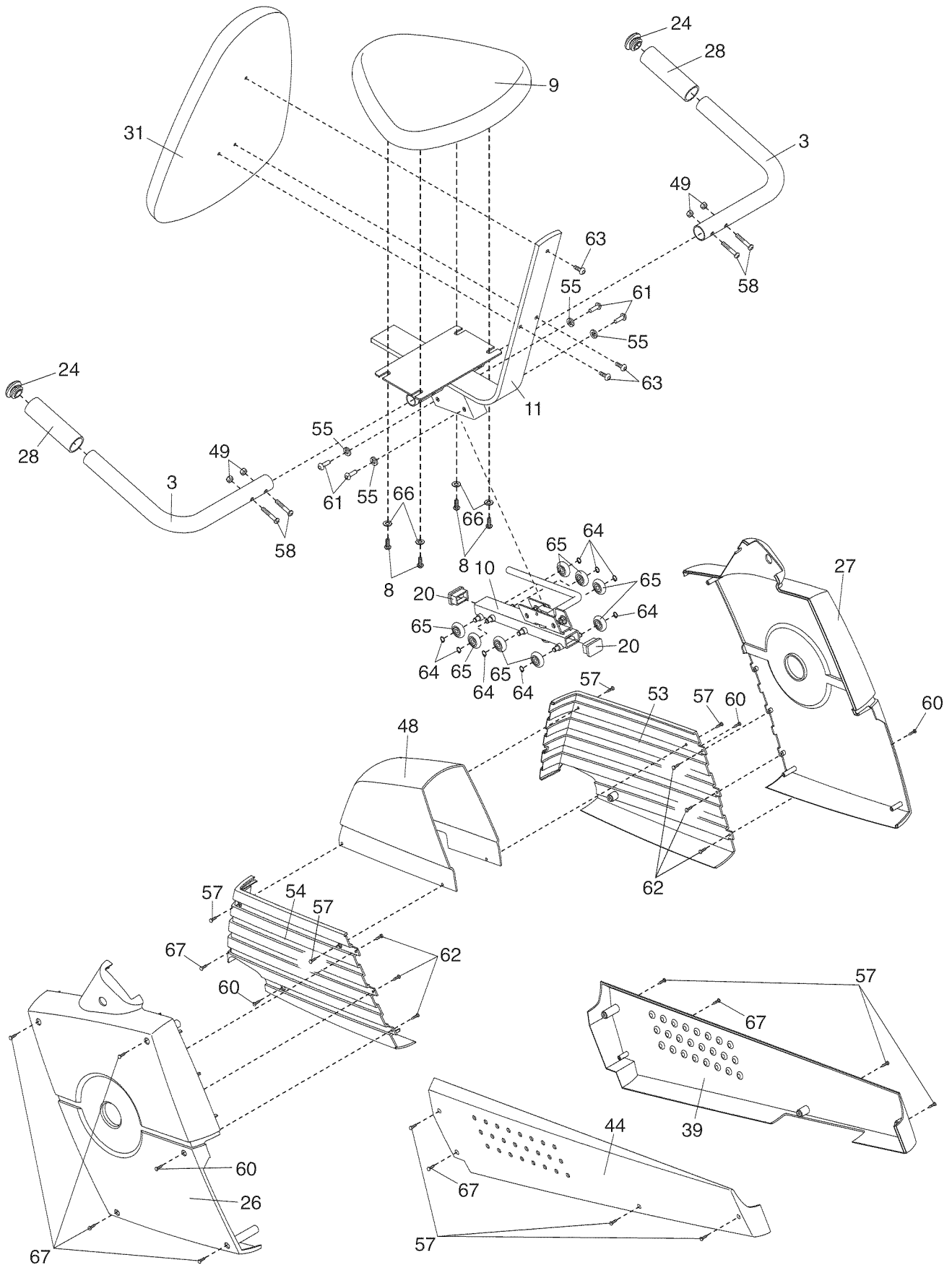

EXPLODED DRAWING B—Model No. 831.21522.1

R0406A

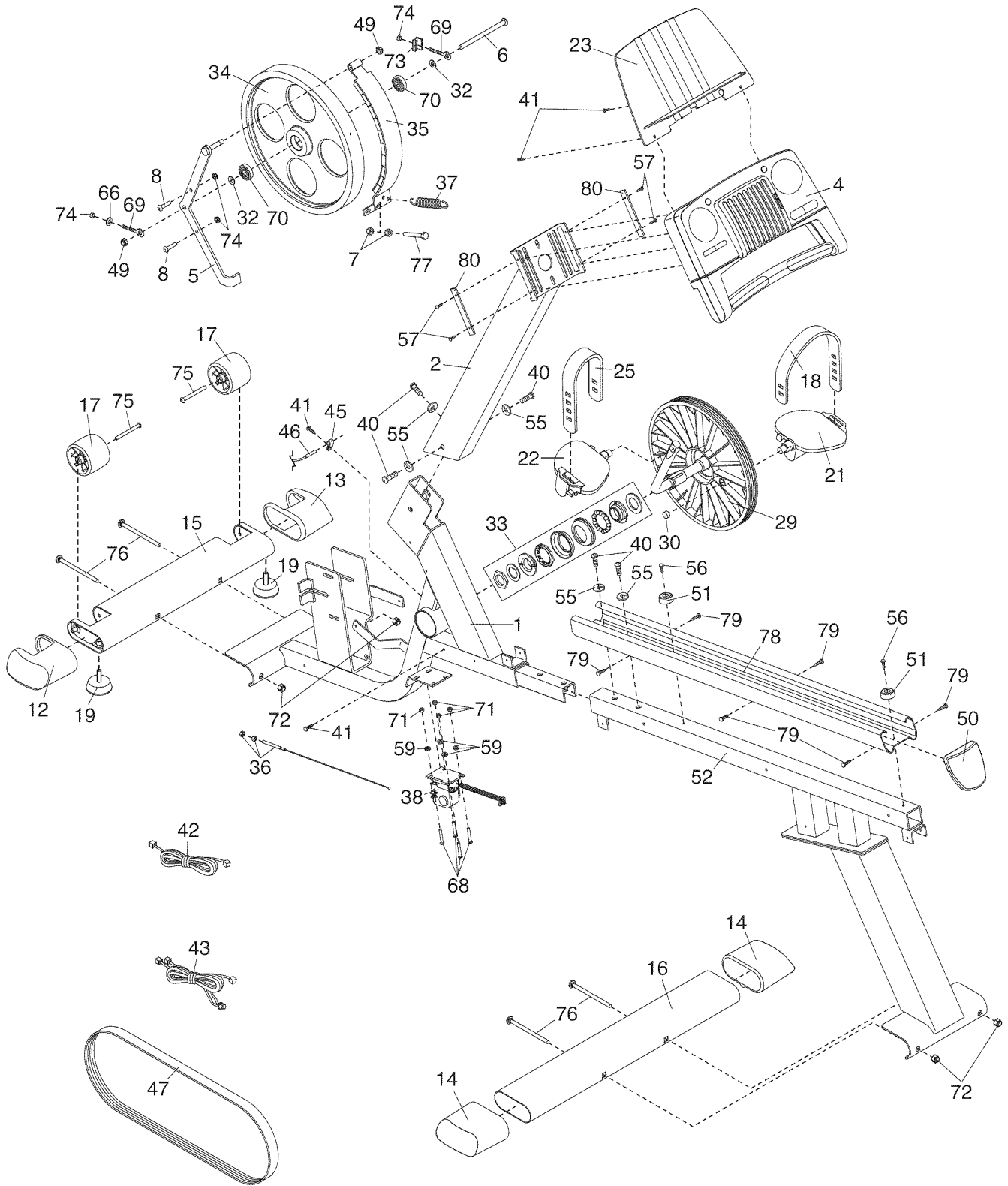

Get it fixed, at your home or ours!

Your Home

For repair—**in your home**—of **all** major brand appliances, lawn and garden equipment, or heating and cooling systems, **no matter who made it, no matter who sold it!**

For the replacement parts, accessories, and user's manuals that you need to do-it-yourself.

For Sears professional installation of home appliances and items like garage door openers and water heaters.

1-800-4-MY-HOME® (1-800-469-4663)

Call anytime, day or night (U.S.A. and Canada)

www.sears.com

www.sears.ca

Our Home

For repair of carry-in items like vacuums, lawn equipment, and electronics, call or go on-line for the location of your nearest **Sears Parts & Repair Center.**

1-800-488-1222 Call anytime, day or night (U.S.A. only)

www.sears.com

To purchase a protection agreement (U.S.A.) or maintenance agreement (Canada) on a product serviced by Sears:

1-800-827-6655 (U.S.A.)

1-800-361-6665 (Canada)

Para pedir servicio de reparación a domicilio, y para ordenar piezas:

1-888-SU-HOGAR® (1-888-784-6427)



® Registered Trademark / ™ Trademark / ™ Service Mark of Sears Brands, LLC
© Marca Registrada / ™ Marca de Fábrica / ™ Marca de Servicio de Sears Brands, LLC

90 DAY FULL WARRANTY

If this Sears Bike Exerciser fails due to a defect in material or workmanship within 90 days of the date of purchase, call 1-800-4-MY-HOME® (1-800-469-4663) to arrange for free repair (or replacement if repair proves impossible).

This warranty does not apply when the Bike Exerciser is used commercially or for rental purposes.

This warranty gives you specific legal rights, and you may also have other rights which vary from state to state.

Sears, Roebuck and Co., Hoffman Estates, IL 60179