

SEARS Operator's Manual

CRAFTSMAN[®]

26cc 2-Cycle GASOLINE BLOWER

Model No.
358.798940

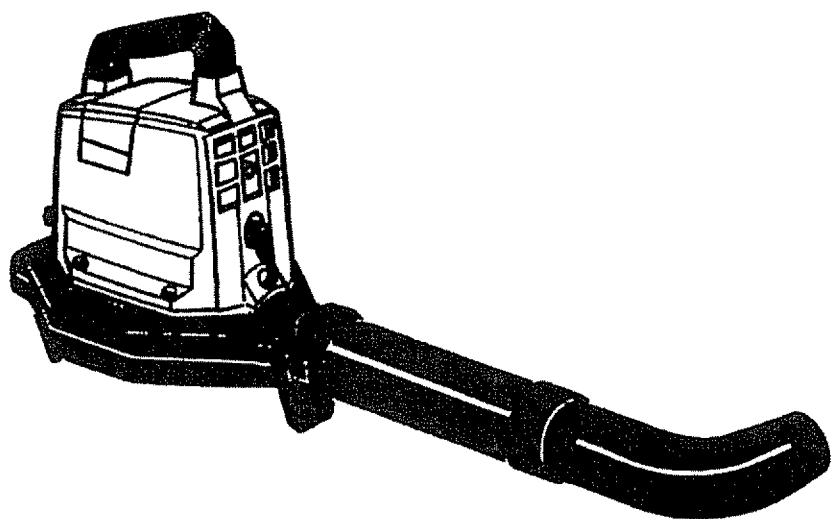

WARNING:
Read and follow all Safety Rules and Operating Instructions before first use of this product.



For answers to your questions about this product:
Call 7 am–7 pm, Mon–Sat; Sun, 10 am–7 pm

1-800-235-5878

Sears, Roebuck and Co., Hoffman Estates, IL 60179 USA

530-084330 04/11/96

SAFETY

ASSEMBLY

OPERATION

MAINTENANCE

PARTS LIST

ESPAÑOL

TABLE OF CONTENTS

Warranty Statement	2	Storage	9
Safety Rules	2	Troubleshooting Chart	10
Assembly	4	Parts List	11
Operation	5	Spanish	15
Maintenance	7	Parts Ordering	Back Cover
Service & Adjustments	8		

WARRANTY STATEMENT

FULL ONE YEAR WARRANTY ON CRAFTSMAN® GAS BLOWER

For one (1) year from the date of purchase, when this Gas Blower is maintained, lubricated and tuned up according to the operating and maintenance instructions in the owner's manual, Sears will repair, free of charge, any defect in materials or workmanship.

This warranty excludes blower tubes, spark plug, and air cleaner, which are expendable parts and become worn during normal use.

If this Blower is used for commercial purposes, this warranty applies for only 90 days from the date of purchase. If this Blower is used for rental purposes, this warranty applies for only 30 days from the date of purchase. This warranty applies only while this product is in use in the United States.

WARRANTY SERVICE IS AVAILABLE BY RETURNING THE BLOWER TO THE NEAREST SEARS SERVICE CENTER IN THE UNITED STATES.

This warranty gives you specific legal rights, and you may also have other rights which vary from state to state.

Sears, Roebuck and Co. Dept. D/817WA Hoffman Estates, IL 60179

SAFETY RULES

Failure to follow all Safety Rules and Precautions can result in serious injury.

KNOW YOUR UNIT

- Read your Operator's Manual carefully until you completely understand and can follow all warnings and safety rules before operating the unit.
- Restrict unit to users who understand and will follow all warnings and safety rules in this manual.

PLAN AHEAD

- Always wear eye protection when operating, servicing, or performing maintenance on unit. Wearing eye protection will help to prevent rocks or debris from being blown or ricocheting into eyes and face which can result in blindness and/or serious injury.
- Always wear respirator or face mask when working with unit in dusty environments.

- Secure hair above shoulder length. Secure or remove jewelry, loose clothing, or clothing with loosely hanging straps, ties, tassels, etc. They can be caught in moving parts.
- Do not operate unit when you are tired, ill, upset, or if you are under the influence of alcohol, drugs, or medication.
- Keep children, bystanders, and animals away from work area a minimum of 50 feet (15 m) when starting or operating unit.
- Inspect the area before starting the unit. Remove all debris and hard objects such as rocks, glass, wire, etc. that can ricochet, be thrown, or otherwise cause injury or damage during operation.

HANDLE FUEL WITH CAUTION

- Eliminate all sources of sparks or flame (including smoking, open flames, or work that can cause

sparks) in the areas where fuel is mixed, poured, or stored.

- Mix and pour fuel in an outdoor area; store fuel in a cool, dry, well ventilated place; use an approved, marked container for all fuel purposes.
- Do not smoke while handling fuel or while operating the unit.
- Do not fill fuel tank while engine is running.
- Wipe up fuel spills before starting engine.
- Move at least 10 feet (3 meters) away from fuel and fueling site before starting engine.

OPERATE YOUR UNIT SAFELY

- Inspect unit before each use for worn, loose, missing, or damaged parts. Do not use until unit is in proper working order.
- Keep outside surfaces free of oil and fuel.
- Never start or run engine inside a closed room or building. Breathing exhaust fumes can kill.
- To avoid static electricity shock, do not wear rubber gloves or any other insulated gloves while operating unit.
- Do not set unit on any surface except a clean, hard area while engine is running. Debris such as gravel, sand, dust, grass, etc. could be picked up by the air intake and thrown out through discharge opening, damaging unit, property, or causing serious injury to bystanders or operator.
- Avoid dangerous environments. Do not use in unventilated areas or where explosive vapors or carbon monoxide build up could be present.
- Do not overreach or use from unstable surfaces such as ladders, trees, steep slopes, rooftops, etc. Keep firm footing and balance at all times.
- Never place objects inside the blower tubes; always direct the blowing debris away from people, animals, glass, and solid objects such as trees, automobiles, walls, etc. The force of air can cause rocks, dirt, or sticks to be thrown or to ricochet which can hurt people or animals, break glass, or cause other damage.
- Never run unit without the proper equipment attached. When using

your unit as a blower, always install blower tubes.

- Check air intake opening, and blower tubes, frequently, always with engine stopped and spark plug disconnected. Keep vents and discharge tubes free of debris which can accumulate and restrict proper air flow.
- Never place any object in the air intake opening as this could restrict proper air flow and cause damage to the unit.
- Never use for spreading chemicals, fertilizers, or other substances which may contain toxic materials.
- To avoid spreading fire, do not use near leaf or brush fires, fireplaces, barbecue pits, ashtrays, etc.
- Use only for jobs explained in this manual.

MAINTAIN YOUR UNIT PROPERLY

- Have all maintenance other than the recommended procedures described in the Operator's Manual performed by Sears Service.
- Disconnect spark plug before performing maintenance except for carburetor adjustments.
- Use only recommended CRAFTSMAN® replacement parts; use of any other parts may void your warranty and cause damage to your unit.
- Empty the fuel tank before storing the unit. Use up fuel left in carburetor by starting the engine and letting it run until it stops.
- Do not use any accessory or attachment other than those recommended by the manufacturer for use with your unit.
- Do not store the unit or fuel in a closed area where fuel vapors can reach sparks or an open flame from hot water heaters, electric motors or switches, furnaces, etc.
- Store in a dry area out of reach of children.

SPECIAL NOTICE: For users on U.S. Forest Land and in some states, including California(Public Resources Codes 4442 and 4443), Idaho, Maine, Minnesota, New Jersey, Oregon, and Washington: Certain internal combustion engines operated on forest, brush, and/or grass covered land in the above areas are required to be equipped with a spark arrestor, maintained in effective

working order, or the engine must be constructed, equipped, and maintained for the prevention of fire. Check with your state or local authorities for regulations pertaining to these requirements. Failure to follow these requirements is a violation of the law. This unit is not factory equipped with a spark arrestor; however, a spark arrestor is available as an optional part. If a spark arrestor is required in your area, contact Sears Service for the correct kit. The spark arrestor, blower tubes, and nozzles must be assembled to unit to be in full compliance with regulations. **SPECIAL NOTICE:** Exposure to vibrations through prolonged use of gasoline powered hand tools could cause

blood vessel or nerve damage in the fingers, hands, and joints of people prone to circulation disorders or abnormal swelling. Prolonged use in cold weather has been linked to blood vessel damage in otherwise healthy people. If symptoms occur such as numbness, pain, loss of strength, change in skin color or texture, or loss of feeling in the fingers, hands, or joints, discontinue the use of this tool and seek medical attention. An antivibration system does not guarantee the avoidance of these problems. Users who operate power tools on a continual and regular basis must monitor closely their physical condition and the condition of this tool.

ASSEMBLY

CARTON CONTENTS

Check carton contents against the following list.

Model 358.798940

- Blower
- Blower tube
- Nozzle
- Container of oil

NOTE: It is normal for the fuel filter to rattle in the empty fuel tank.

ASSEMBLY

WARNING: If received assembled, repeat all steps to ensure your unit is

properly assembled and all fasteners are secure.

- No tools are required for assembly.

BLOWER TUBE

- Assemble the blower tube and nozzle to the unit (turn clockwise to tighten).

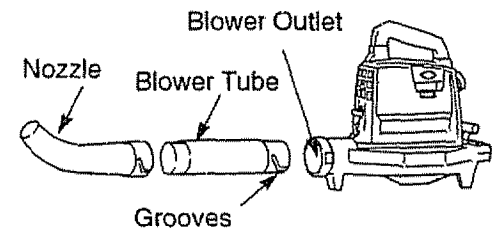

OPERATION

KNOW YOUR GAS BLOWER

READ THIS OPERATOR'S MANUAL AND SAFETY RULES BEFORE OPERATING YOUR UNIT. Compare the illustrations with your unit to familiarize yourself with the location of the various controls and adjustments. Save this manual for future reference.

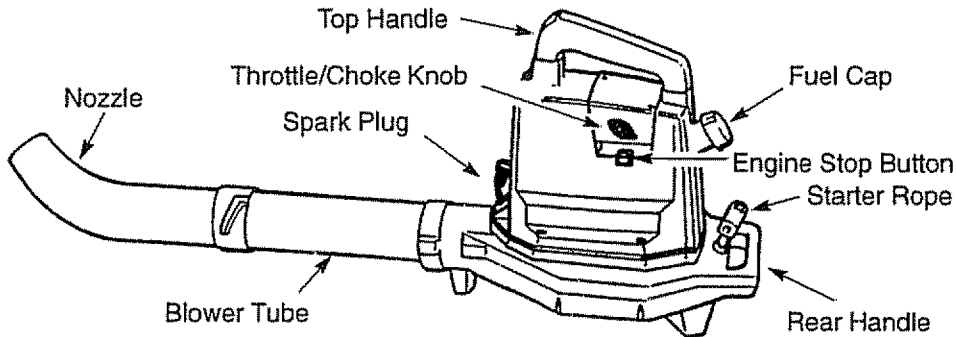

ENGINE STOP BUTTON

The engine stop button is used to stop the engine. To STOP the engine, press and hold the button in the STOP position.

PRIMER BULB

The primer bulb removes air from the fuel lines and fills them with fuel. This allows you to start the engine with fewer pulls on the starter rope. Activate the primer bulb by pressing it and allowing it to return to its original form.

CHOKE

The choke helps to supply fuel to the carburetor during starting. This allows you to start a cold engine. Activate the choke by moving the choke lever to the Full or Half position. After the engine has started, move the choke lever to the Full Throttle position.

BEFORE STARTING ENGINE

WARNING: Be sure to read the fuel information in the safety rules before you begin. If you do not understand the safety rules, do not attempt to fuel your unit. Call 1-800-235-5878.

FUELING ENGINE

This engine is certified to operate on unleaded gasoline. Before operation, gasoline must be mixed with a good quality 2-cycle air-cooled engine oil. We recommend Craftsman brand oil. Mix gasoline and oil at a ratio of 40:1 (A 40:1 ratio is obtained by mixing 3.2 ounces of oil with 1 gallon of unleaded gasoline). DO NOT USE automotive oil or boat oil. These oils will cause engine

damage. When mixing fuel, follow instructions printed on container. Once oil is added to gasoline, shake container momentarily to assure that the fuel is thoroughly mixed. Always read and follow the safety rules relating to fuel before fueling your unit.

IMPORTANT

Experience indicates that alcohol blended fuels (called gasohol or using ethanol or methanol) can attract moisture which leads to separation and formation of acids during storage. Acidic gas can damage the fuel system of an engine while in storage.

To avoid engine problems, empty the fuel system before storage for 30 days or longer. Drain the gas tank, start the engine and let it run until the fuel lines and carburetor are empty. Use fresh fuel next season.

Never use engine or carburetor cleaner products in the fuel tank or permanent damage may occur.

See the STORAGE section for additional information.

Blower

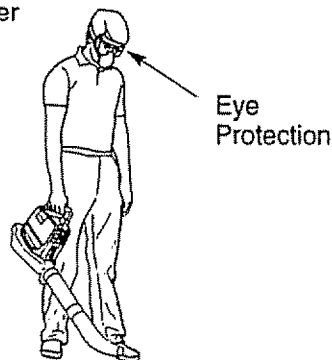

STOPPING YOUR ENGINE

- Press and hold the Engine Stop Button in the STOP position.
- If engine does not stop, move the choke to the Full position.

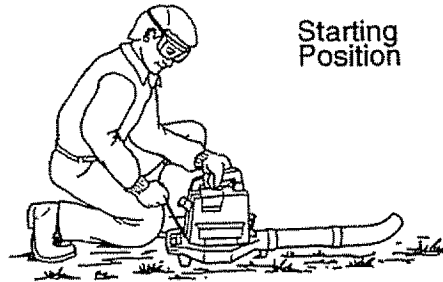

STARTING YOUR ENGINE BEFORE STARTING THE ENGINE

You MUST make sure the tubes are secure before using the unit.

- Fuel engine. Move at least 10 feet (3 meters) away from the fueling site.
- Hold the unit in the starting position as shown. Make sure the blower end is directed away from people, animals, glass, and solid objects.

WARNING: When starting engine, hold the unit as illustrated. Do not set unit on any surface except a clean, hard area when starting engine or while engine is running. Debris such as gravel, sand, dust, grass, etc. could be picked up by the air intake and thrown out through the discharge opening, damaging the unit or property, or causing serious injury to bystanders or the operator.

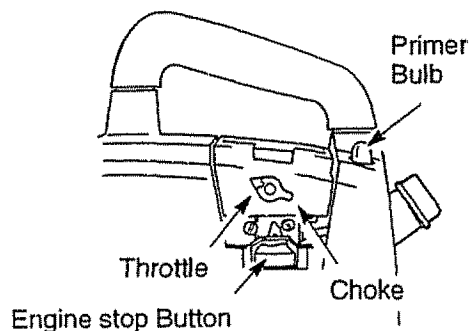

STARTING A COLD ENGINE OR A WARM ENGINE AFTER RUNNING OUT OF FUEL

- Move choke to FULL position.
- Press primer bulb 6 times.
- Pull starter rope sharply until engine attempts to run, but no more than 8 pulls on full choke.

NOTE: If the engine sounds as if it is trying to start before the 8th pull, go to the next step.

- Move choke to HALF position.
- Pull starter rope sharply until engine runs, but no more than 5 pulls.

NOTE: If engine has not started after 5 pulls, repeat all of the above steps.

- Allow the engine to run for 10 to 15 seconds, then move choke to the Full Throttle position.

NOTE: If engine dies with Throttle at Full Throttle position, move the choke to the Half position and pull the starter rope 5 more times. If engine does not start and operate properly, refer to "Carburetor Adjustments."

- To stop engine, press and hold the Engine Stop Button in the STOP position.

FOR A WARM ENGINE

- Move Throttle to Full Throttle position.
- Press primer bulb 6 times.
- Pull starter rope sharply until engine runs.

NOTE: If engine does not run after 20 pulls, it is probably flooded. Wait a few minutes and repeat procedure with throttle at Full Throttle position.

- To stop engine, press and hold the Engine Stop Button in the STOP position.

DIFFICULT STARTING OR STARTING A FLOODED ENGINE

Flooded engines can be started by placing the choke lever in the Off Choke position and the On/Stop Button in the On position; then, pull the rope to clear the engine of excess fuel. This could require pulling the starter handle many times depending on how badly the unit is flooded.

If the unit still doesn't start, refer to TROUBLESHOOTING chart or call 1-800-235-5878.

MAINTENANCE

CUSTOMER RESPONSIBILITIES

CARE & MAINTENANCE TASK	WHEN TO PERFORM
Check for Loose fasteners and parts	Before each use
Check for damaged or worn parts	Before each use
Clean unit and labels	After each use
Clean air filter	Every 5 hours of operation
Replace spark plug	Yearly

GENERAL RECOMMENDATIONS

The warranty on this unit does not cover items that have been subjected to operator abuse or negligence. To receive full value from the warranty, the operator must maintain unit as instructed in this manual. Various adjustments will need to be made periodically to properly maintain your unit.

CHECK FOR LOOSE FASTENERS AND PARTS

- Spark Plug Boot
- Air Filter
- Housing Screws

CHECK FOR DAMAGED OR WORN PARTS

- Refer replacement of damaged/worn parts to your Sears Service Center.
- Engine Stop Button – Ensure Button functions properly by pressing and holding the button in the "Stop" position. Make sure engine stops; then restart engine and continue.
- Fuel Tank – Discontinue use of unit if fuel tank shows signs of damage or leaks.

CLEAN UNIT & LABELS

- Clean the unit using a damp cloth with a mild detergent.
- Wipe off unit with a clean dry cloth.

CLEAN AIR FILTER

Do not clean filter in gasoline or other flammable solvent. Doing so can create a fire hazard or produce harmful evaporative emissions.

Cleaning the air filter:

A dirty air filter decreases engine performance and increases fuel consumption and harmful emissions. Always clean after every 5 hours of operation.

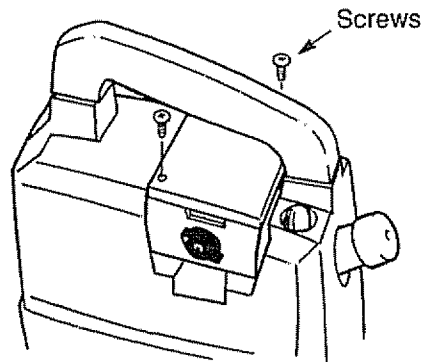

- Clean the cover and the area around it to keep debris from falling into the carburetor chamber when the cover is removed.
- Remove parts as illustrated.

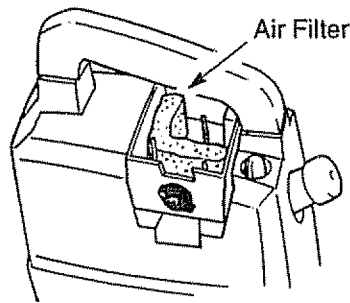

- Wash the filter in soap and water.
- Allow filter to dry.
- Replace parts.

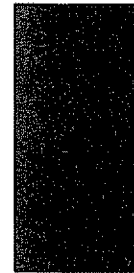

REPLACE SPARK PLUG

Replace spark plug each year to ensure the engine starts easier and runs better. Set spark plug gap at .025 in. Ignition timing is fixed, nonadjustable.

- Twist, then pull off spark plug boot.

- Remove spark plug from cylinder and discard.
- Replace with Champion RCJ-8Y spark plug and tighten with a 3/4 in. socket wrench (10-12 ft.-lbs).
- Reinstall the spark plug boot.

SERVICE AND ADJUSTMENTS

We recommend all service and adjustments not listed in this manual be performed by your Sears Service Center.

CARBURETOR ADJUSTMENT

Carburetor adjustment is critical and if done improperly can permanently damage the engine as well as the carburetor. If you require further assistance or are unsure about performing this procedure, call our customer assistance help line at 1-800-235-5878.

Old fuel, a dirty air filter, a dirty fuel filter, or flooding may give the impression of an improperly adjusted carburetor. Check these conditions before adjusting the carburetor.

The carburetor has been carefully set at the factory. Adjustments may be necessary if you notice any of the following conditions:

- Engine will not idle. See "Idle Speed" and "Mixture" under adjusting procedure.
- Engine dies or hesitates instead of accelerating. See "Acceleration Check" under adjusting procedure.
- Loss of power. See "Mixture" under adjusting procedure.

There are two adjustment screws on the carburetor. They are located in the area below the throttle/choke knob.

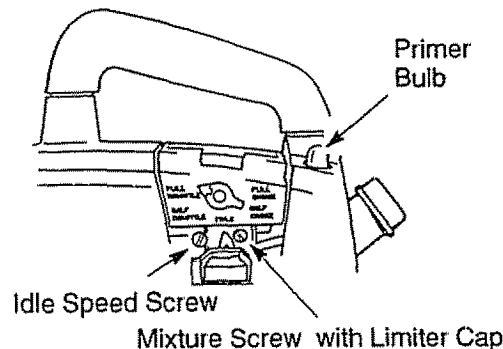

CARBURETOR PRESETS

When making carburetor preset adjustments, do not force plastic limiter caps beyond the stops or damage will occur.

If carburetor presets are not needed, proceed to "ADJUSTING PROCEDURE, Idle Speed."

To adjust presets:

- Turn the mixture screw counterclockwise until it stops.
- Turn the idle speed screw clockwise until it stops. Now turn counterclockwise 4-1/2 turns.

Start motor, let it run for 3 minutes, and proceed to the adjustment section. If engine does not start, refer to troubleshooting chart or call 1-800-235-5878. If engine performance is acceptable at the preset positions, no further adjustments are necessary.

ADJUSTING PROCEDURE

Idle Speed

Allow engine to idle. Adjust speed until engine runs without stalling.

- Turn clockwise to increase engine speed if engine stalls or dies.
- Turn counterclockwise to decrease speed.

No further adjustments are necessary if performance is satisfactory.

Mixture

Allow engine to idle. Then accelerate the engine and note performance. If engine hesitates, bogs down, or smokes during acceleration, turn mixture screw clockwise in 1/16-turn increments until performance is satisfactory. Repeat this procedure as necessary for proper adjustment. After completing adjustments, check for acceleration. Reset if necessary.

Acceleration Check

If engine dies or hesitates instead of accelerating, turn low speed mixture adjustment counterclockwise until you have smooth acceleration. Recheck and adjust as necessary for acceptable performance.

STORAGE

Prepare unit for storage at end of season or if it will not be used for 30 days or more.

WARNING:

- Allow engine to cool, and secure the unit before storing or transporting.
- Store unit and fuel in a well ventilated area where fuel vapors cannot reach sparks or open flames from water heaters, electric motors or switches, furnaces, etc.
- Store unit with all guards in place. Position unit so that any sharp object cannot accidentally cause injury.
- Store unit and fuel well out of the reach of children.

EXTERNAL SURFACES

- If your unit is to be stored for a period of time, clean it thoroughly before storage. Store in a clean dry area.
- Lightly oil external metal surfaces.

FUEL SYSTEM

Under Fueling Engine in the Operating Section of this manual, see message labeled **IMPORTANT** regarding the use of gasohol in your engine.

Fuel stabilizer is an acceptable alternative in minimizing the formation of fuel gum deposits during storage. Add sta-

bilizer to the gasoline in the fuel tank or fuel storage container. Follow the mix instructions found on stabilizer container. Run engine at least 5 minutes after adding stabilizer.

CRAFTSMAN 40:1, 2-cycle engine oil (air cooled) is already blended with fuel stabilizer. If you do not use this Sears oil, you can add a fuel stabilizer to your fuel tank.

INTERNAL ENGINE

- Remove spark plug and pour 1 teaspoon of 40:1, 2-cycle engine oil (air cooled) through the spark plug opening. Slowly pull the starter rope 8 to 10 times to distribute oil.
- Replace spark plug with new one of recommended type and heat range.
- Clean air filter.
- Check entire unit for loose screws, nuts, and bolts. Replace any damaged, broken, or worn parts.
- At the beginning of the next season, use only fresh fuel having the proper gasoline to oil ratio.

OTHER

- Do not store gasoline from one season to another.
- Replace your gasoline can if it starts to rust.

TROUBLESHOOTING CHART

TROUBLE	CAUSE	REMEDY
Engine will not start.	<ul style="list-style-type: none"> • Engine flooded. • Fuel tank empty. • Spark plug not firing. • Fuel not reaching carburetor. • Compression low. 	<ul style="list-style-type: none"> • See "Starting Instructions." • Fill tank with correct fuel mixture. • Install new spark plug. • Check for dirty fuel filter; replace. Check for kinked or split fuel line; repair or replace. • Contact Sears Service.
Engine will not idle properly.	<ul style="list-style-type: none"> • Carburetor requires adjustment. • Crankshaft seals worn. • Compression low. 	<ul style="list-style-type: none"> • See "Carburetor Adjustments." • Contact Sears Service. • Contact Sears Service.
Engine will not accelerate, lacks power, or dies under a load.	<ul style="list-style-type: none"> • Air filter dirty. • Spark plug fouled. • Carburetor requires adjustment. • Carbon build up. • Compression low. 	<ul style="list-style-type: none"> • Clean or replace air filter. • Clean or replace spark plug and re-gap. • See "Carburetor Adjustments." • Contact Sears Service. • Contact Sears Service.
Engine smokes excessively.	<ul style="list-style-type: none"> • Choke partially on. • Fuel mixture incorrect. • Air filter dirty. • Carburetor requires adjustment. 	<ul style="list-style-type: none"> • Adjust choke. • Empty fuel tank and refill with correct fuel mixture. • Clean or replace air filter. • See "Carburetor Adjustments."
Engine runs hot.	<ul style="list-style-type: none"> • Fuel mixture incorrect. • Spark plug incorrect. • Carburetor requires adjustment • Carbon build up. 	<ul style="list-style-type: none"> • See "Fueling Your Unit." • Replace with correct spark plug. • See "Carburetor Adjustments." • Contact Sears Service.