

# Kenmore

SEWING MACHINE 12332



OWNER'S MANUAL

## Sears, Roebuck and Co.

Dear Homemaker:

You have just invested in a very fine zigzag sewing machine. Before using your new Kenmore machine, please pause for a moment and carefully read this booklet which contains instructions on how to operate and care for your machine.

Specific instructions are given on threading, tension adjustments, cleaning, oiling, etc. This will help you obtain the best sewing results and avoid unnecessary service expense for conditions beyond our control.

Advice on the operation and care of your machine is always available at your nearest Sears Retail Store. Please remember, if you have questions about your machine, always mention the model number and serial number when you inquire.

### Kenmore Sewing Machine

**Record in space provided below the model number and serial number of this appliance. The model number and serial number are located on the nomenclature plate, as identified on Page 2 of this booklet.**

**Model No. 385. \_\_\_\_\_ Serial No. \_\_\_\_\_**  
**Retain these numbers for future reference.**

## TABLE OF CONTENTS

### KNOWING YOUR SEWING MACHINE

Machine identification . . . . .	2
Accessories . . . . .	4
Setting spool pins . . . . .	5
Installing extension table . . . . .	5
Pressure regulator, Presser foot lever . . . . .	6
Presser feet, Speed control plug . . . . .	7
Light and power switch, Sewing light . . . . .	8
Foot control, Seam guides, Darning plate . . . . .	9
Needle, thread and fabric chart . . . . .	10
Needles, Placement of needle . . . . .	11
Winding the bobbin . . . . .	12
Threading the bobbin case . . . . .	13
Threading top thread . . . . .	14
Picking up bobbin thread . . . . .	15
Adjusting top thread tensions . . . . .	16
Adjusting bobbin tensions . . . . .	16

### SIMPLE SEWING

Straight stitching . . . . .	17
Fastening a seam, Turning a square corner . . . . .	18
Zigzag stitching . . . . .	19
Checking tensions, Overcasting, Interfacing darts . . . . .	20

### STRETCH AND UTILITY STITCH SEWING

Stretch stitching . . . . .	21
Adjusting stretch stitch balance . . . . .	21
Straight stretch stitching . . . . .	22
Rick-rack stretch stitching . . . . .	23
Buttonhole making . . . . .	24
Adjusting buttonhole stitch balance . . . . .	26
Satin stitching, Appliqueing . . . . .	27
Zipper application . . . . .	28
Darning . . . . .	29
Button sewing, Bar tacking . . . . .	30
Free-arm sewing . . . . .	31

### CHECKING PERFORMANCE PROBLEMS . . . . . 32

### CARING FOR THE MACHINE

Cleaning feed dogs and shuttle . . . . .	34
Oiling under arm cover plate . . . . .	35
Oiling underside . . . . .	36
Oiling in face cover plate . . . . .	37
Parts list . . . . .	38

### USING PORTABLE CASE OR CABINET . . . . . 40

# KNOWING YOUR SEWING MACHINE

## MACHINE IDENTIFICATION

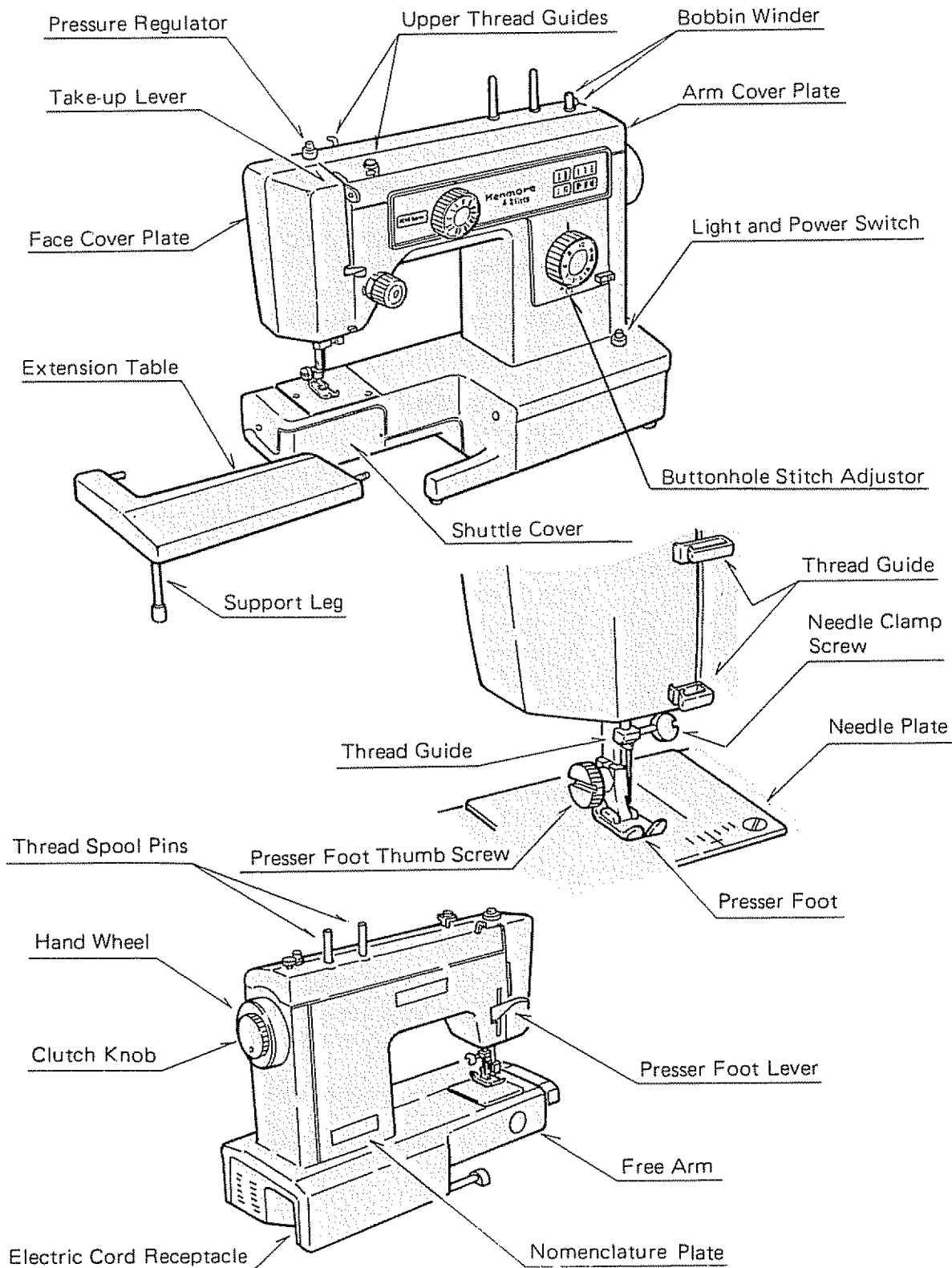

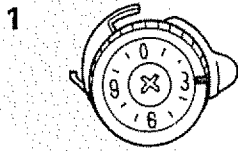
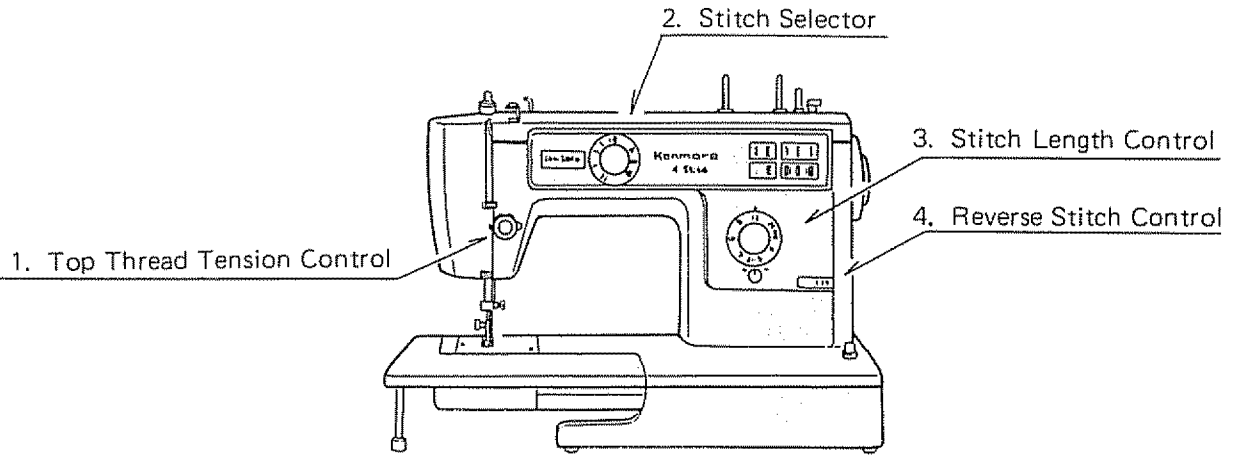

This control regulates your top thread tension.  
The higher the number, the tighter the tension.

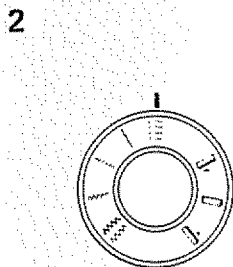

The stitch selector control not only determines the stitch you select, but also regulates the stitch width. The different types of stitches are designated by color.

- Utility Stitches are orange
- Stretch Stitches are yellow
- Buttonhole settings are green

Note: Be sure your needle is up and out of fabric when adjusting this control.

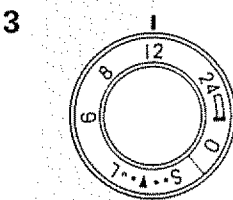

The stitch length control regulates the length of the stitch calibrated in stitches per inches.  
The higher the number, the shorter the stitch.

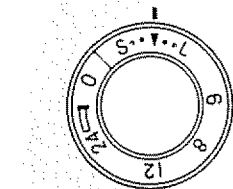

When you want to stretch stitch, set this control at ▼ position.

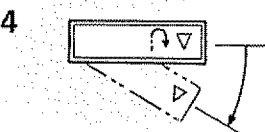

To reverse stitch, turn this control clockwise. Hold down during sewing. Release to sew forward again.

# ACCESSORIES

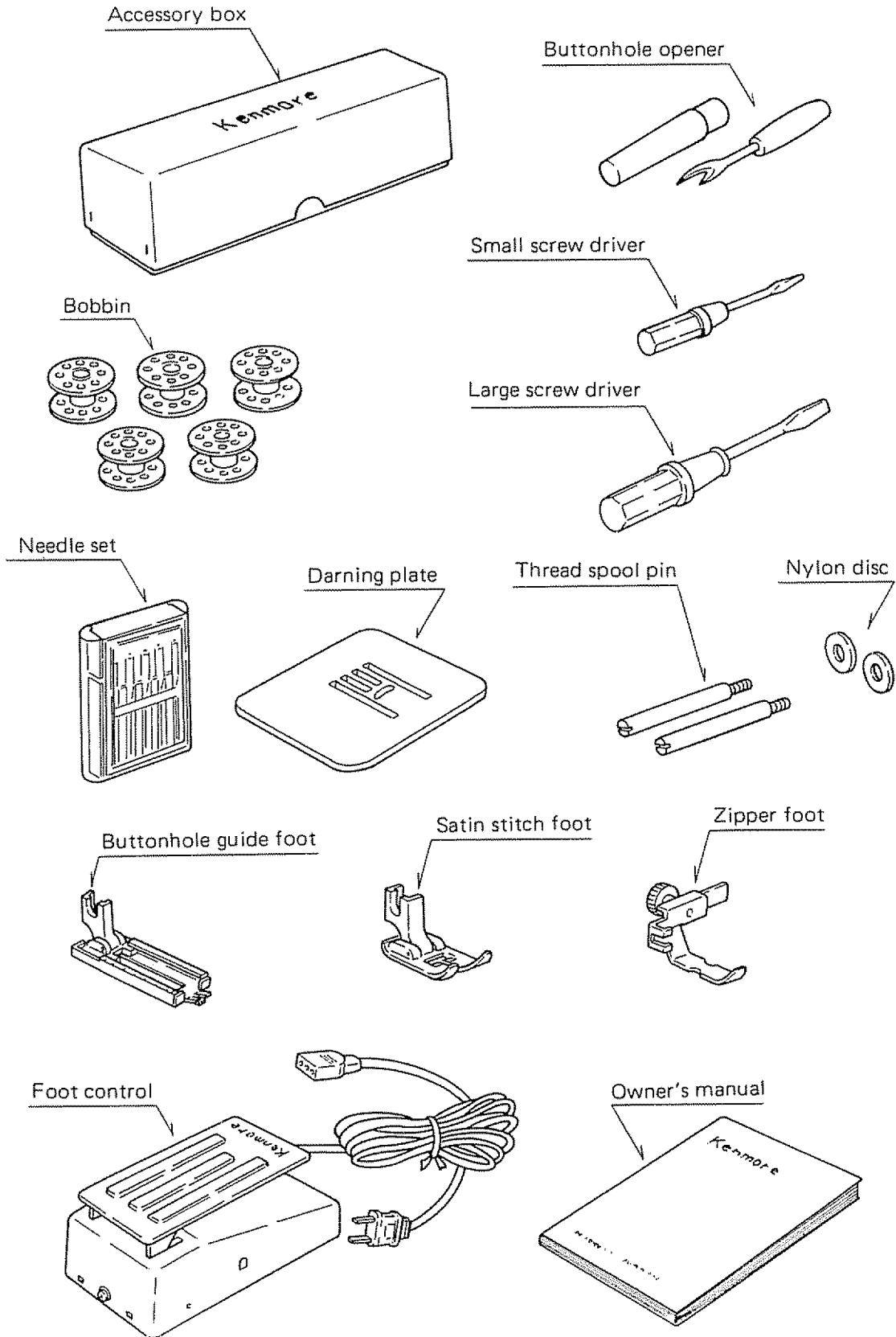

## SETTING SPOOL PINS

Spool Pins are packed in accessory box.

Screw thread spool pins in place securely with a screw driver.

Position nylon discs as shown in illustration.

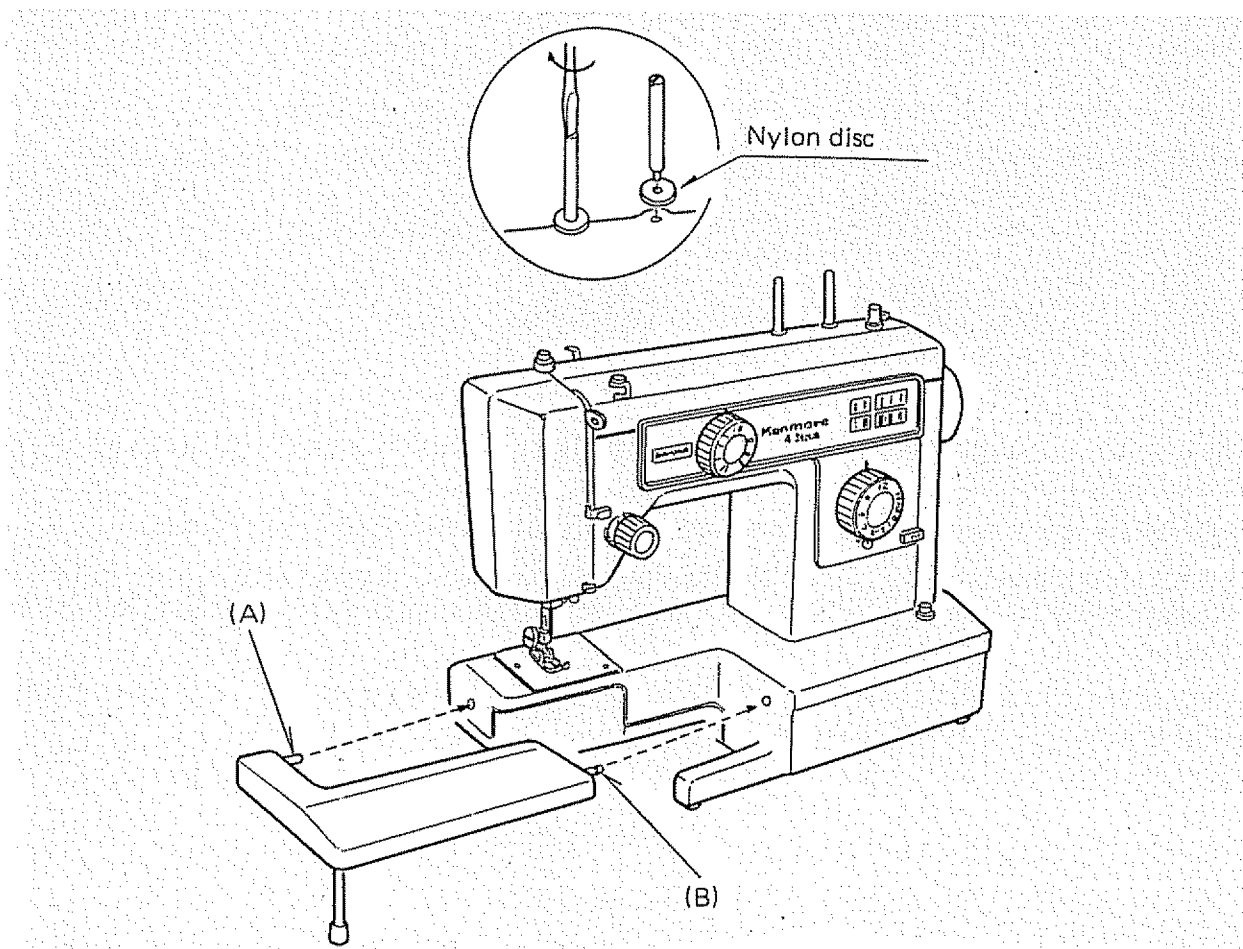

## INSTALLING EXTENSION TABLE

For all flat-bed sewing use the extension table provided with the machine. To install the extension table, simply slide the table along the free arm until the two Pins (A) and (B) enter fitting holes in the machine.

Lower the support leg.

To utilize free-arm feature for sewing tubular material, remove the extension table from the machine by pulling it to the left.

---

## PRESSURE REGULATOR

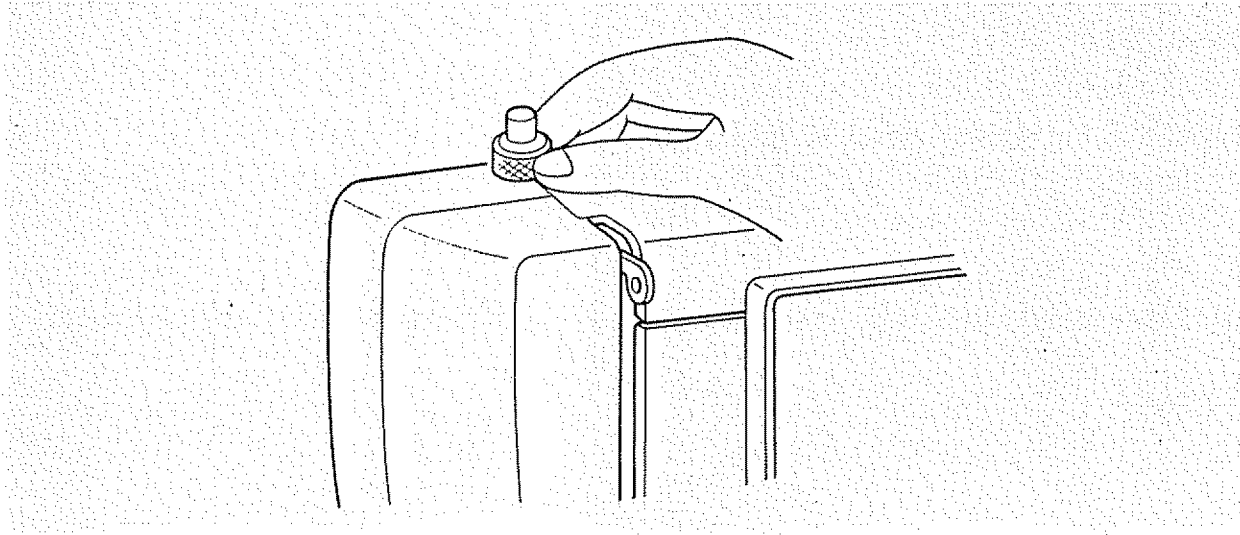

Push down the outer ring of the pressure regulator. This will release the pressure on the presser foot. (See above).

To increase the pressure, push down inner pin until suitable pressure is obtained.

Insufficient pressure may cause poor feeding of the fabric, skipped stitches, or difficulty in guiding the fabric. If feed dogs or presser foot marks appear on the fabric, reduce the pressure.

When sewing multiple thickness or heavy fabric, reduce the pressure. Increase pressure when sewing lighter weight fabrics.

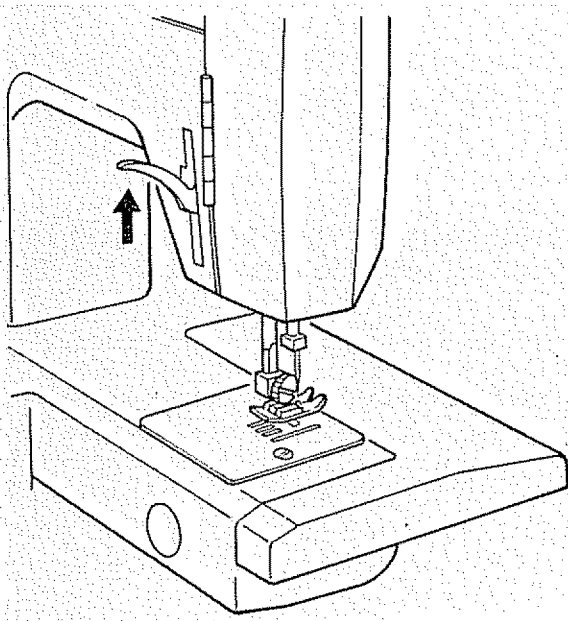

## PRESSER FOOT LEVER

To aid you in the placement of heavy fabrics under the presser foot, the lever can raise foot beyond the normal "up" position. This is also an aid in changing your presser feet.



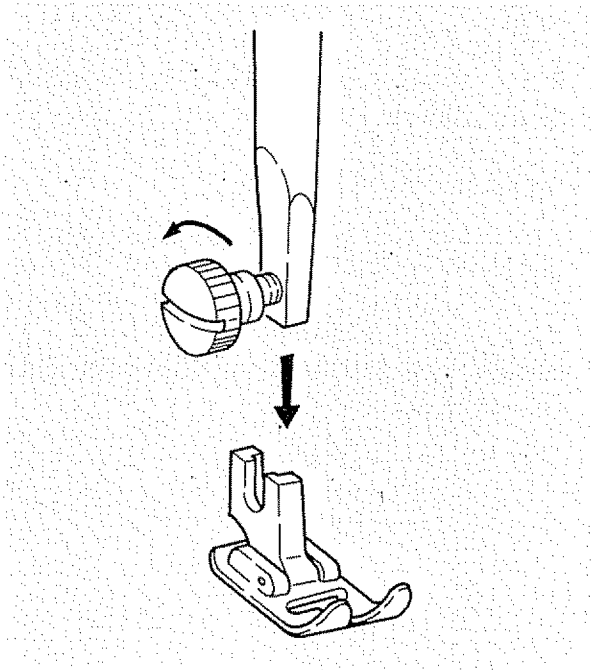

## PRESSER FEET

To change the various presser feet, raise the presser bar to its highest position by lifting the presser foot lever. Loosen the presser foot thumb screw, choose the proper foot, insert from the bottom. Tighten the screw using the large screw driver to make certain the foot is secure.

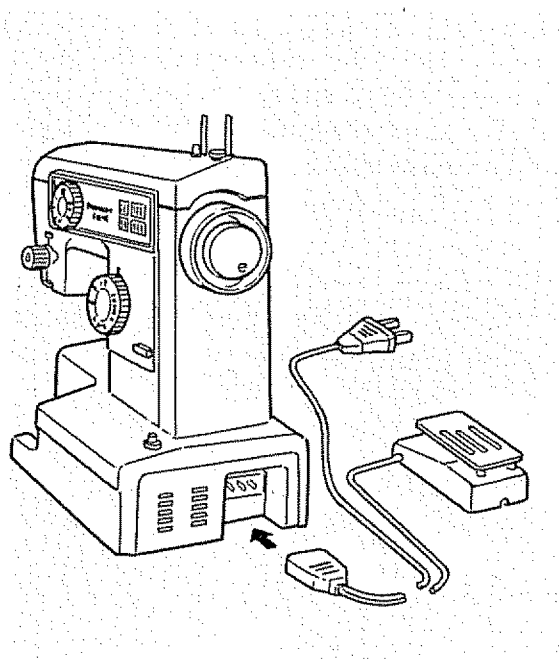

## SPEED CONTROL PLUG

Push the speed control plug onto three prong connector.

Plug machine cord into any 110 ~ 120 volt wall outlet.

---

## LIGHT AND POWER SWITCH

Turn on power by pushing light and power switch.

### Important safety feature

Your machine will not operate unless the light/power switch is turned on. Turning on the power automatically illuminates the whole stitching area. If you're interrupted or stop sewing, turn off light/power switch.

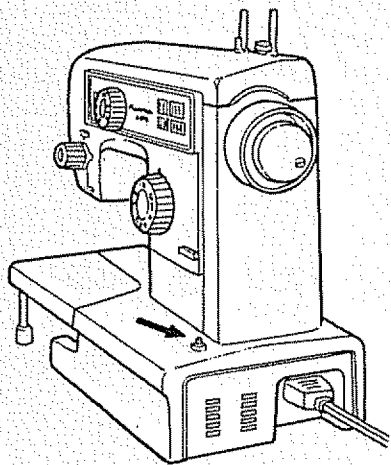

## SEWING LIGHT

The sewing light is located in the face cover as shown. To replace the bulb, turn the light off and open the face cover. Push the bulb up and turn the bulb counter-clockwise and remove it from the socket.

Push a new bulb in and turn it clockwise.

### NOTE:

First, unplug the machine prior to removing and replacing the bulb. Be aware that the light bulb may be warm.

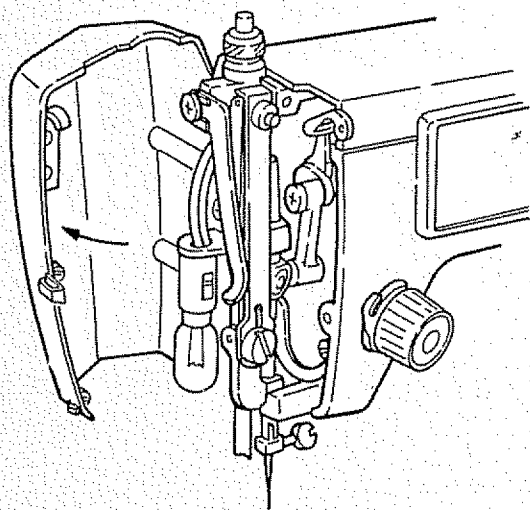

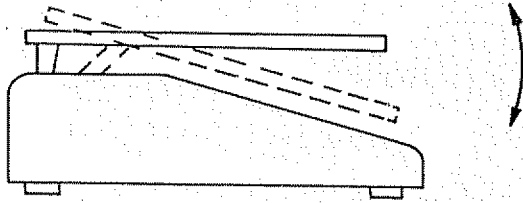

## FOOT CONTROL

Step on this control to start to sew. The harder you press on the control, the faster the machine will sew. Slow down by reducing foot pressure on the control. You may want to practice your speed at different levels when you first use the machine.

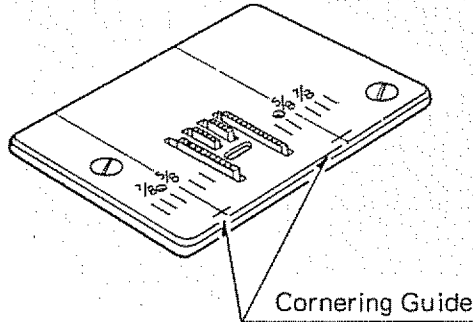

## SEAM GUIDES

Seam guides are printed on either side of the needle plate to aid you in guiding your fabric. THE GUIDE LINE EXTENDING ALONG THE RIGHT SIDE OF THE NEEDLE PLATE IS THE "ALL IMPORTANT" 5/8" SEAM LINE.

The cornering guides are convenient when turning a square corner 5/8" from the fabric edge. See next section of this book for directions.

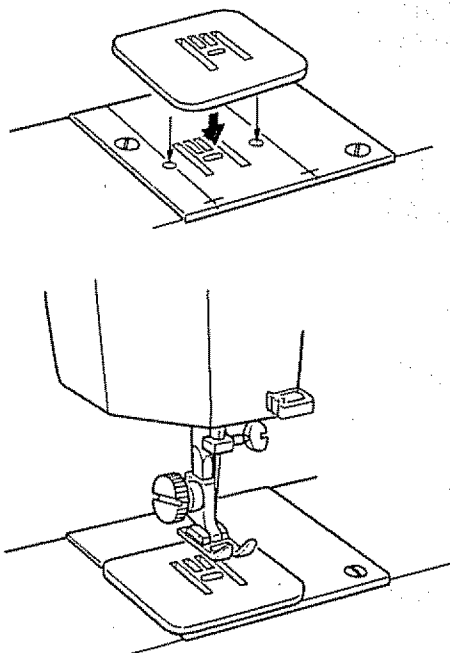

## DARNING PLATE

There are a few times when you want to control the feeding of the fabric yourself. Raise needle to its highest position and raise presser foot. Place darning plate over needle plate aligning two pins of darning plate with holes of needle plate. You may then determine the movement of the fabric yourself. See page 30 for button sewing application.

## NEEDLE, THREAD AND FABRIC CHART

FABRIC	NEEDLE SIZE AND COLOR	THREAD SIZE	RECOMMENDED STITCH LENGTH SETTING
<b>Lightweight:</b> Batiste, Dimity, Chiffon, Silks, Synthetic Jerseys, Fine Lace, Organza, Crepe, Taffeta, Voile, Organdy	9-BROWN or 11-ORANGE	Polyester Core/Cotton Wrap Fine Mercerized Cotton Silk A	12 stitches per inch
<b>Medium Weight:</b> Cotton, Cotton Blends, Percale, Gingham, Shantung, Pique, Seersucker, Satin, Knits, Vinyl Suitings, Linen, Wool Crepe, Leather	14-RED	50 Mercerized Cotton Polyester Core/Cotton Wrap Silk A	10 to 12 stitches per inch
<b>Medium Heavy Weight:</b> Corduroy, Denim, Wool, Sailcloth, Wool Flannel, Gabardine, Velvets, Leather	14-RED or 16 PURPLE	50 Mercerized Cotton Mercerized Heavy-Duty Polyester Core/Cotton Wrap Silk A	8 to 10 stitches per inch
<b>Heavy Weight:</b> Coatings, Upholstery Cotton Duck, Heavy Twills, Canvas	18-GREEN	Heavy Duty Mercerized Cotton Polyester Core/Cotton Wrap Silk A	8 stitches per inch
<b>Decorative top-stitching on all types of fabric</b>	16-PURPLE 18-GREEN or Q BLUE	Buttonhole Twist (Use as top thread only)	6 stitches per inch
<b>Synthetic Knits and Stretch:</b> Polyester Double Knits, Nylon Tricot, Jersey, Stretch Terry, Spandex, Cire Tricot	Q-BLUE with "Q FOOT"™	Polyester Core Cotton Wrap 50 Mercerized Cotton	10 for Regular or 6 for Stretch Stitches

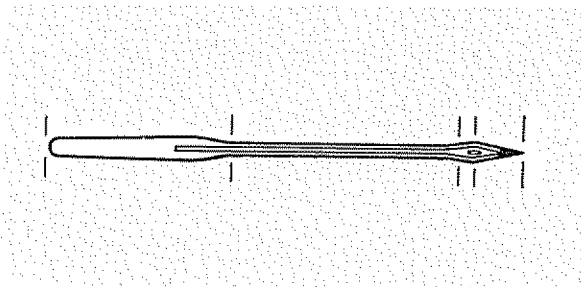

## NEEDLES

Use KENMORE needles. The size of the needle should conform with the size of the thread and both should suit the fabric. Kenmore needles are color-coded by size for your convenience (See chart on facing page).

Never use a bent needle or one with a dull point.

The exact length of your needle is shown at left. Be sure you never use one in your machine that is not this exact length.

You will find among your accessories a Q NEEDLE™ with blue shank. This special needle is to be used when sewing knits and certain difficult synthetic fabrics. If you experience skipped stitches in any of your sewing, use Q NEEDLE™ and Q FOOT™\*.

\* Available at most Sears retail stores and catalog.

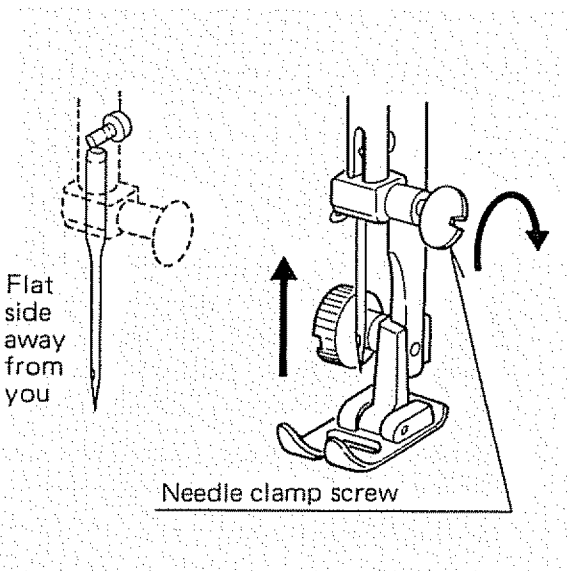

## PLACEMENT OF NEEDLE

Raise needle bar to its highest position by turning the hand wheel toward you. Loosen the needle clamp screw. Holding the needle with the flat side away from you, slip the needle into the needle bar. When it is in as far as it will go, tighten the needle clamp screw with small screwdriver provided in the accessory box.

## WINDING THE BOBBIN

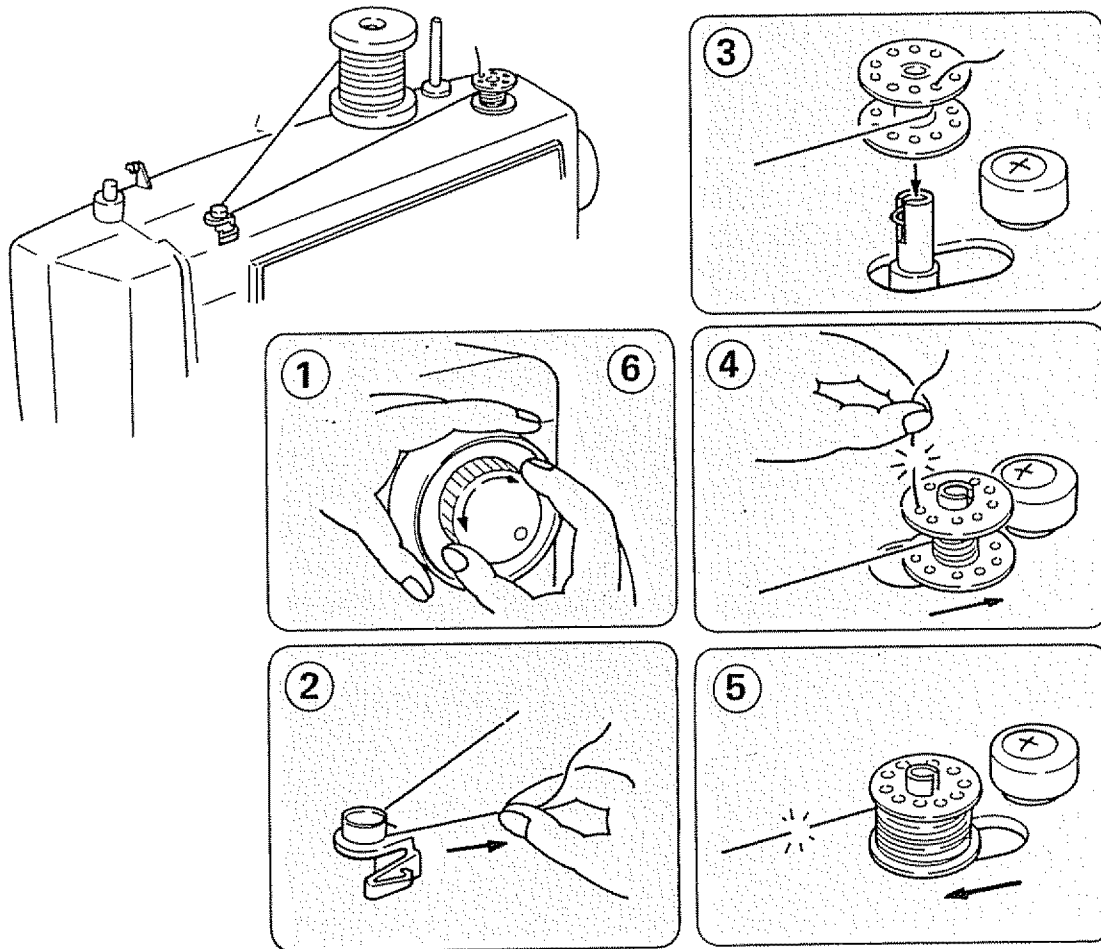

1. Release clutch by turning clutch knob toward you.
2. Draw thread from spool through bobbin winder tension disc as shown.
3. Pull end of thread through hole in bobbin as shown.
4. Place bobbin onto bobbin winder shaft with end of thread coming from

- the top of the bobbin. Push bobbin winder shaft to the right until it clicks. Holding onto end of thread, start machine. When bobbin is slightly filled, snip off end of thread.
5. Wind thread until winder stops. Remove bobbin. Clip thread.
6. Tighten clutch knob.

## THREADING THE BOBBIN CASE

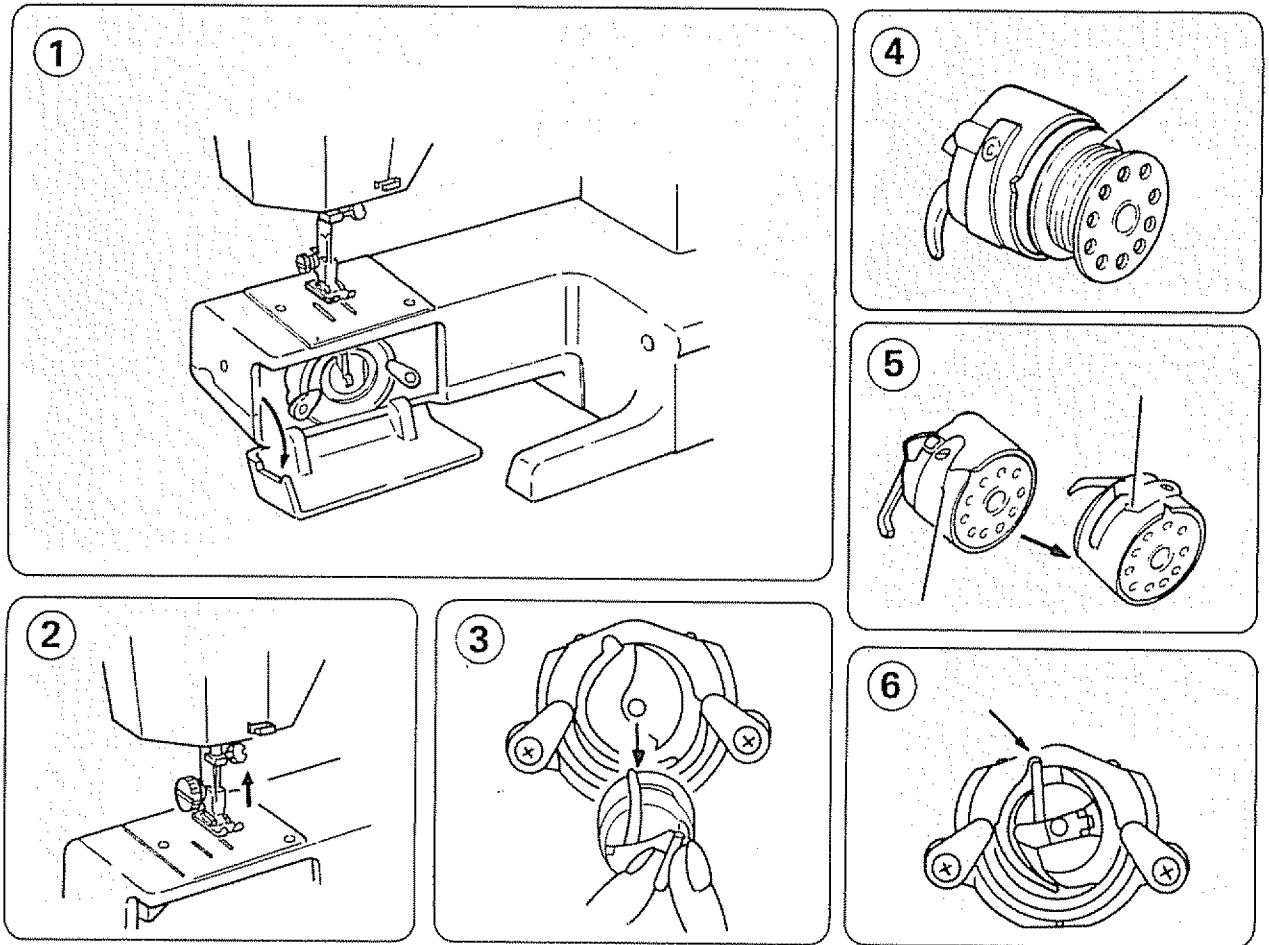

1. Remove the extension table from the machine by pulling it to the left. Open the shuttle cover by pulling down the embossed part on the left side of the cover.
2. Raise needle to its highest position by rotating hand wheel toward you.
3. To remove bobbin case from shuttle, pull open latch of bobbin case. Pull bobbin case straight out of shuttle.
4. Insert bobbin into bobbin case making sure thread is coming from bobbin as shown.
5. Pull thread through slot of case as shown.  
Pull thread under tension spring.
6. Holding latch open, position case into shuttle, and release latch. Case should lock into place when latch is released.

## THREADING TOP THREAD

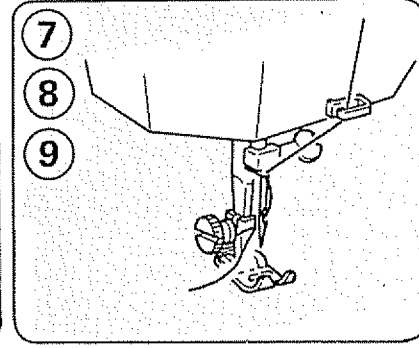
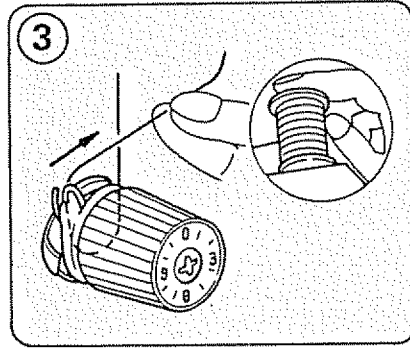
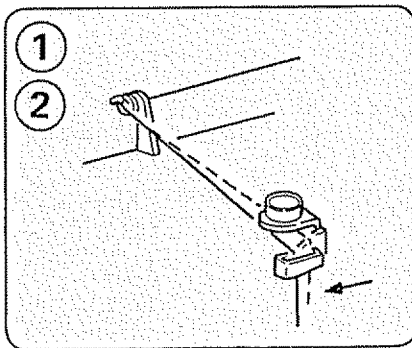
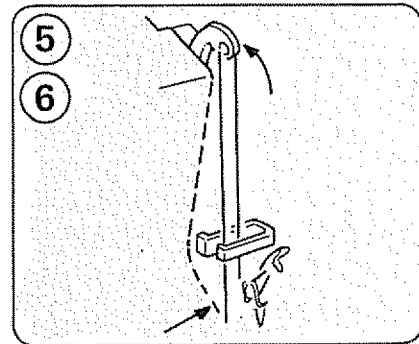
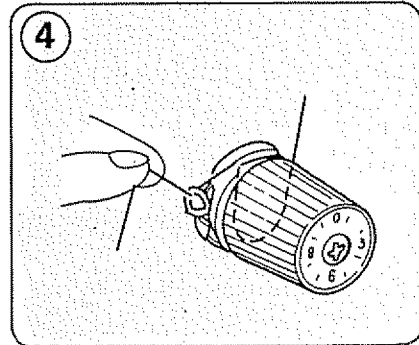
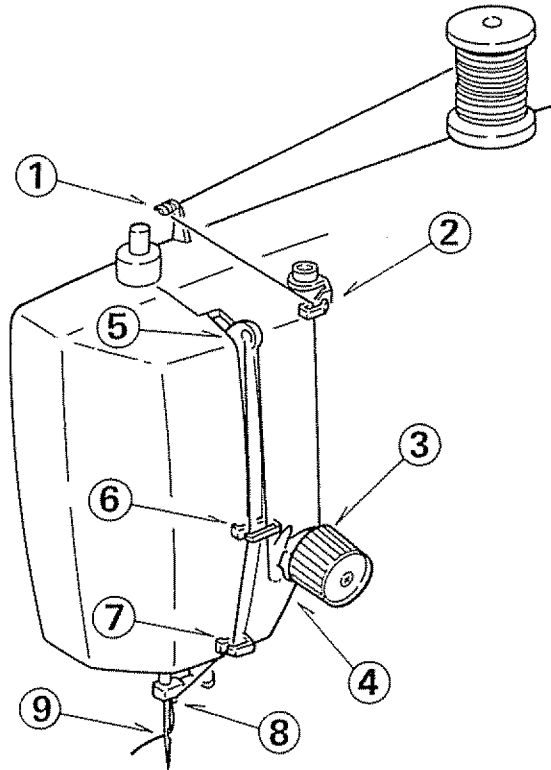

Place spool on spool pin as shown, with thread coming from the back of the spool.

Draw thread through top thread guides. Holding spool stationary with right hand, pull the end of the thread between the tension discs as shown above (3).

Pull the end of the thread taut with left hand. This will pull the spring wire up and past the end of the hook. The thread will then slip into the hook when the spring is released as in (4).

Release spool of thread and thread machine through take-up lever (5) and thread guide (6) as shown above. Thread then passes through guides (7) and (8). Thread needle (9) from front to rear.



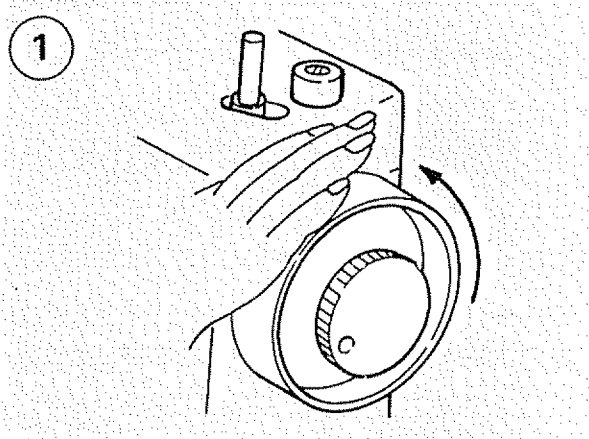

## PICKING UP BOBBIN THREAD

1. Raise presser foot lever. Hold needle thread loosely in left hand and rotate handwheel toward you one complete turn.

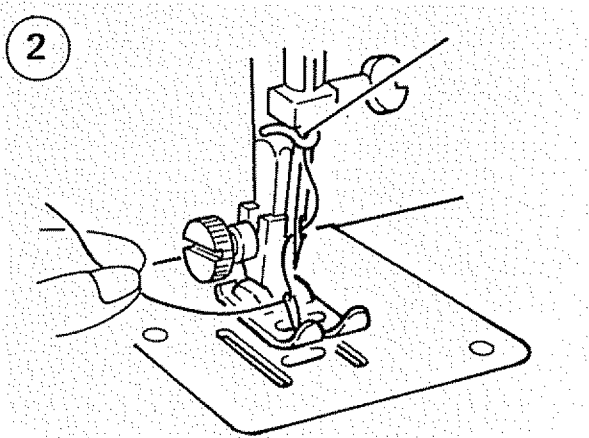

2. Bring bobbin thread up by pulling upper thread.

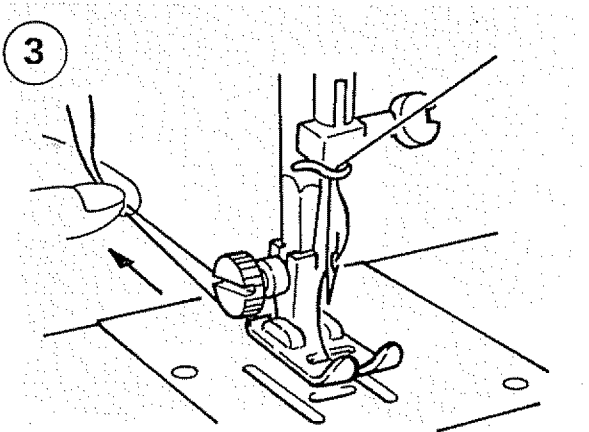

3. Pull both threads under and to the back of the presser foot, leaving 3 to 4 inches of thread clear.

If you cannot pick up bottom thread by following steps given above, then check:

1. Is needle threaded from front to back?
2. Is thread tangled around needle?
3. Is there 3 to 4 inches of thread coming from the bobbin case?
4. Is thread from bobbin case tangled?

## ADJUSTING TOP THREAD TENSIONS

Probably the most important control on your machine is this one that regulates your top thread tension.

There are many reasons for having to reset your tension. The best tension for one fabric may not be correct for another. The required tension depends upon the stiffness of the fabric, thickness of the fabric, numbers of layers of fabric being sewn, as well as the type of stitch you are making.

It is best to test the stitching on a scrap of the fabric you are using before starting to make a garment. Use the straight stitch function as shown at the right.

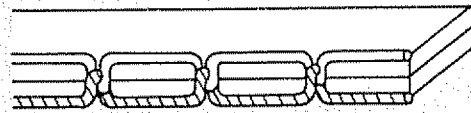

An ideal straight stitch will have threads locked between the two layers of fabric.

Upper thread too tight

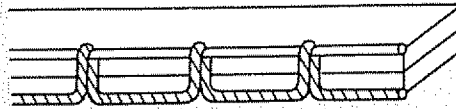

Decrease Tension

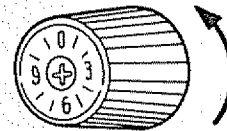

Upper thread too loose

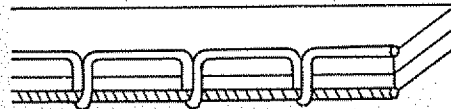

Increase Tension

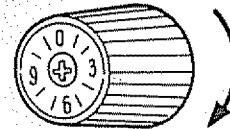

## ADJUSTING BOBBIN TENSIONS

Bobbin tension requires adjusting less frequently than the upper thread tension.

If the stitch is satisfactory but the seam is puckered, it may be necessary to loosen the tension on both the top and bottom threads. Be sure to balance them.

When adjusting the tension on the bobbin case, make slight adjustments with a screw driver.

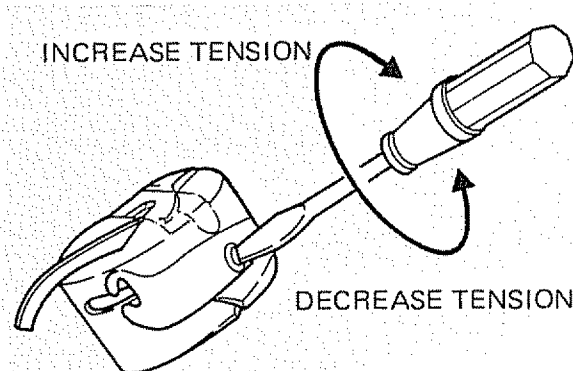

# SIMPLE SEWING

## STRAIGHT STITCHING

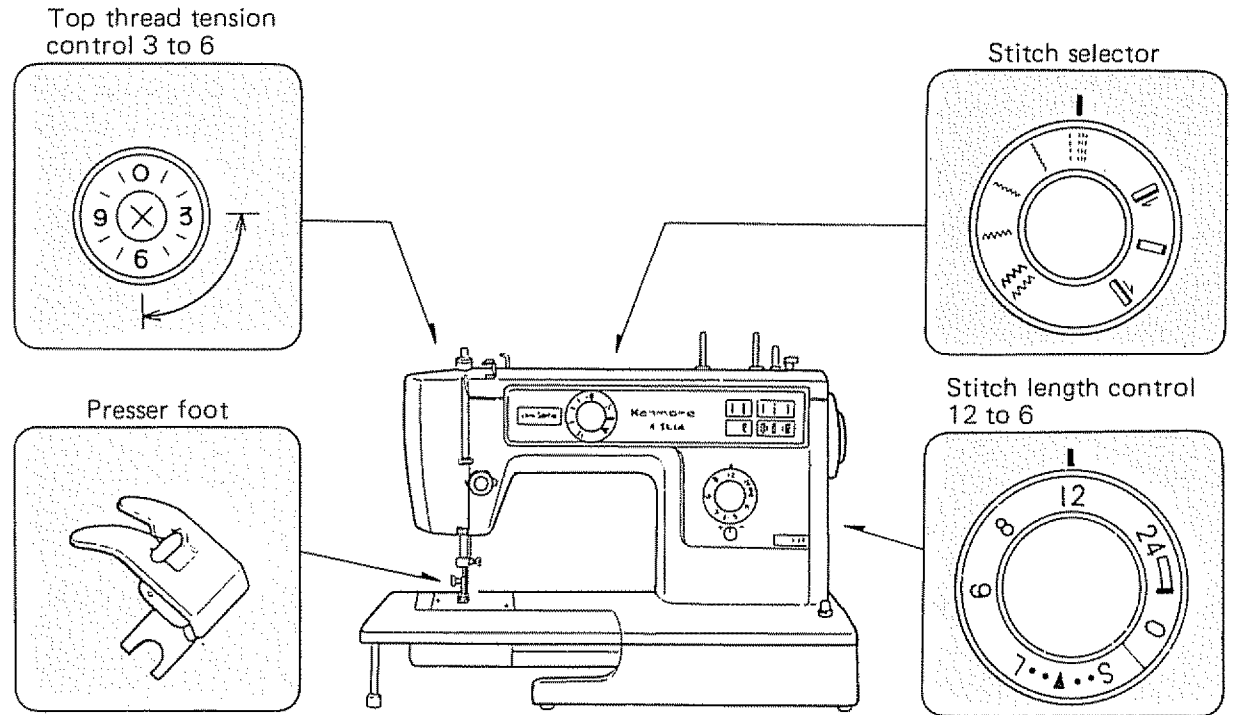

You will find in garment construction that you are doing two types of sewing-temporary and permanent.

1. Temporary stitching-Usually the longest stitch possible and often done on a single layer of fabric. The various types of temporary stitching are:

- Basting
- Stay stitching
- Guide line marking

2. Permanent stitching. This is the actual stitching that holds the garment together. Much of this stitching is visible on the outside of the garment and therefore must be good looking.

The best length stitch to use for medium weight fabrics is 10-12 stitches per inch. This is in the middle range of the Stitch Length Control.

You must remember to lengthen the stitch for heavier fabrics, multiple layers of fabric and thicker seams. Some of these seams are:

- Common two layer seams
- Curved two layer seams
- Top stitched three layer seams
- Top stitched four layer seams

When you have two seams crossing each other with considerable thickness, sew slowly and carefully so the seam will be as strong as possible in this area.

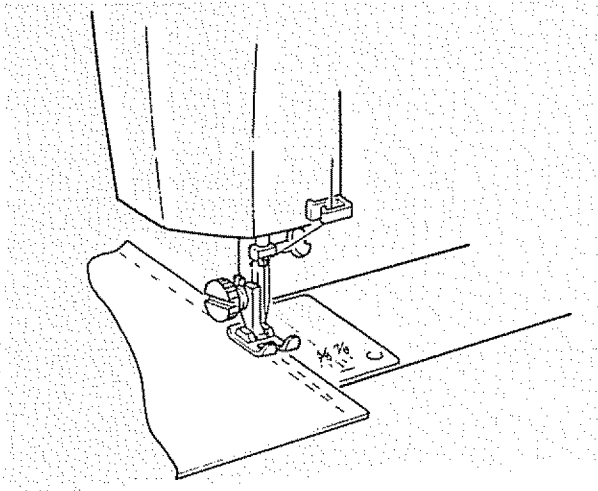

## FASTENING A SEAM

Be sure both threads are drawn back under the presser foot. Lower needle into fabric about 1/2 inch from beginning of seam. Turn the reverse stitch control clockwise and stitch in reverse until needle reaches beginning of seam. Release control and complete seam. When you reach the end, turn the control clockwise and sew back over 1/2 inch of completed seam.

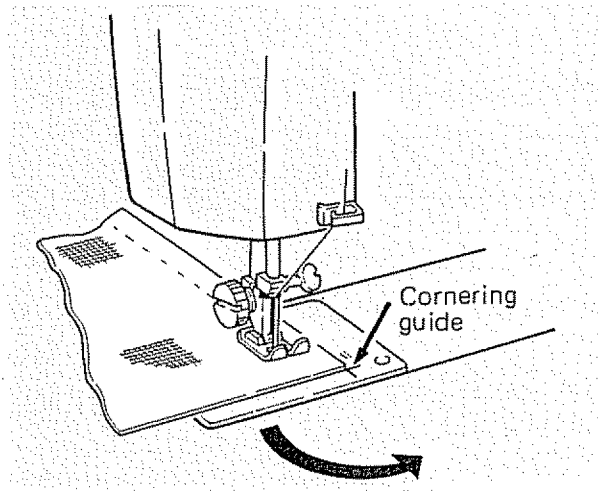

## TURNING A SQUARE CORNER

To turn a square corner 5/8" from the fabric edge, stop stitching with the needle tip piercing the fabric, when reaching the cornering guide as shown. Raise the presser foot, turn fabric. New stitching line will align with 5/8" seam guide on side of needle plate. Lower the presser foot and begin stitching in new direction.

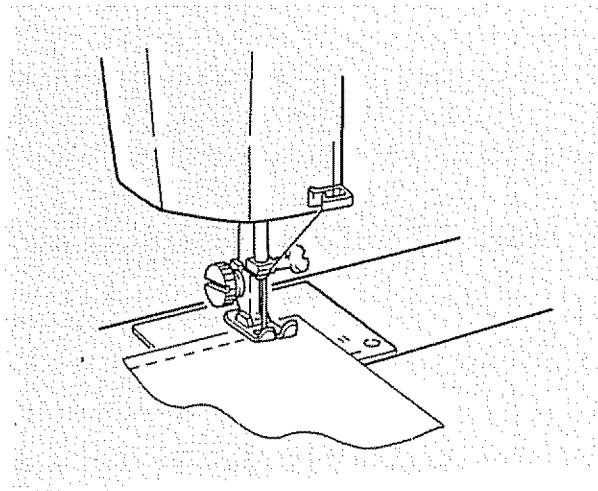

## ZIGZAG STITCHING

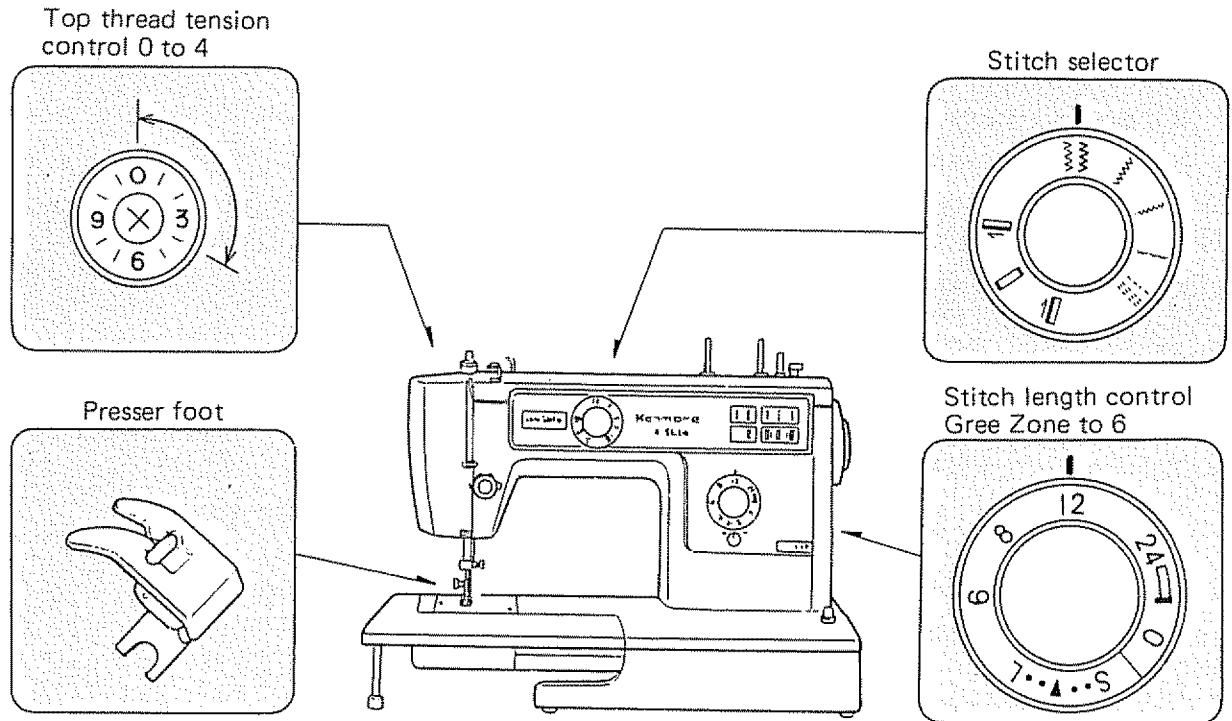

This type of stitching greatly expands the use of your machine. This is the feature that enables you to overcast seams, applique and sew on buttons. Using the range of widths as indicated on the central dial, you can sew any width you desire. Since this is a range, you may set the dial between the illustrated widths.

The following pages will give you directions for utilizing your machine to its greatest potential.

## CHECKING TENSIONS

The easiest way to check tensions is to sew a medium zigzag stitch on the fabric you will be using.

Use the appropriate type of thread and needle. Use different colors of thread on the bobbin and upper spool.

Sew a line of medium zig-zag stitches. The bobbin thread should not show on the top of the fabric.

Adjust the top tension if necessary to achieve the stitch formation mentioned above.

### UNDESIRABLE

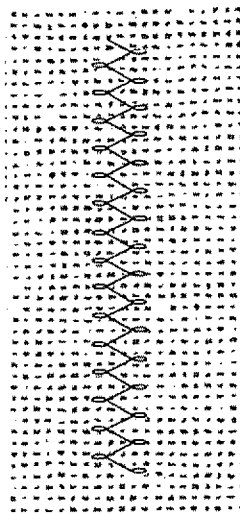

### DESIRABLE

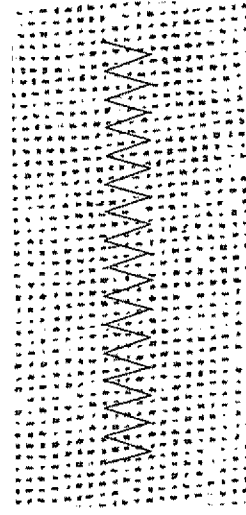

### TOP SIDE OF FABRIC

## OVERCASTING

This is one of the more frequently used zigzag stitches in garment construction. You may want to overcast along the raw edge of each seam allowance or fold the raw edge toward the garment and stitch.

Fig. 1 shows the raw edge finished.  
Fig. 2 illustrates the folded edge stitched.

Stitch so the needle pierces the fabric just short of the outside edge. Raw or worn edges of older garments can be overcast to prevent further raveling.

## INTERFACING DARTS

To reduce bulk of interfacing darts, cut interfacing down center between dart lines. Overlap cut edges, matching dart lines. Zigzag stitch along marking line from point to wide end of dart. Trim both raw edges close to stitching.

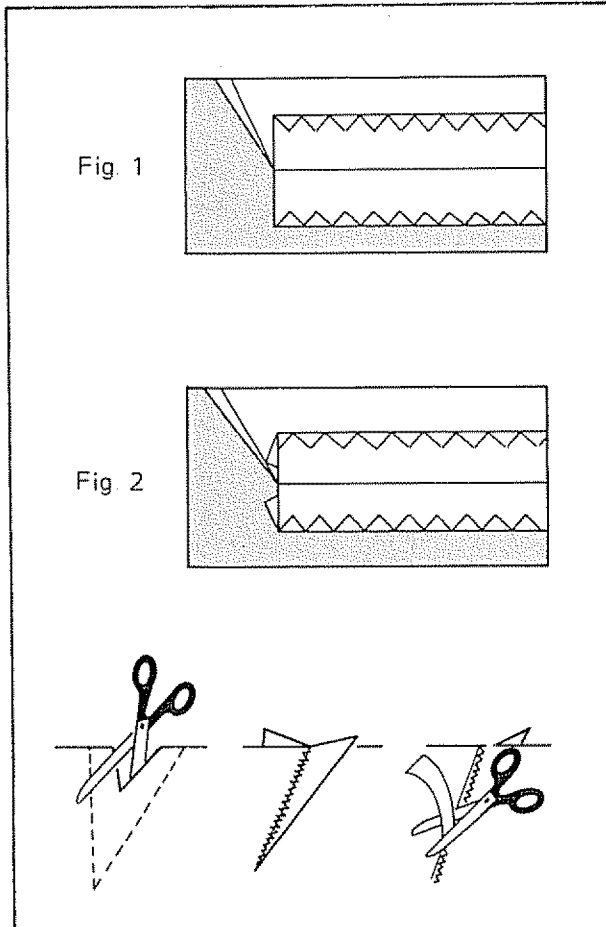

# STRETCH AND UTILITY STITCH SEWING

## STRETCH STITCHING

The stitches shown below are all for use with stretch and knit fabrics. These are special stitches built in to the machine for your quick selection.

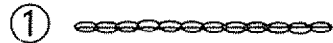

1. Straight Stretch



2. Rickrack Stretch

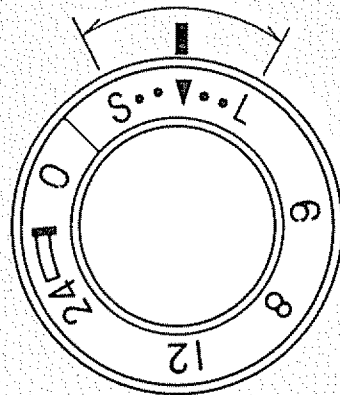

S . . . ▼ . . . L

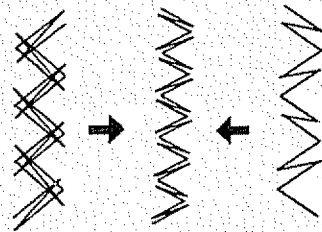

Rickrack Stretch

## ADJUSTING STRETCH STITCH BALANCE

In stretch stitch sewing, Stitch Length Control should be in the detent position between S and L ( ▼ position) for most materials. Depending upon the type of fabric used, you may need to adjust this control to match forward stitches of stretch sewing with reverse motion stitches. To shorten stretch stitches, turn the control slightly toward "S". To lengthen, turn toward "L".

## RECOMMENDATION

1. It is recommended that the "Q" needle and "Q" foot be used for sewing knits and synthetic fabrics.
2. It may be necessary to use a backing with very soft fabrics. Tissue paper is usually available. It can be torn away from seam after sewing.

## STRAIGHT STRETCH STITCHING

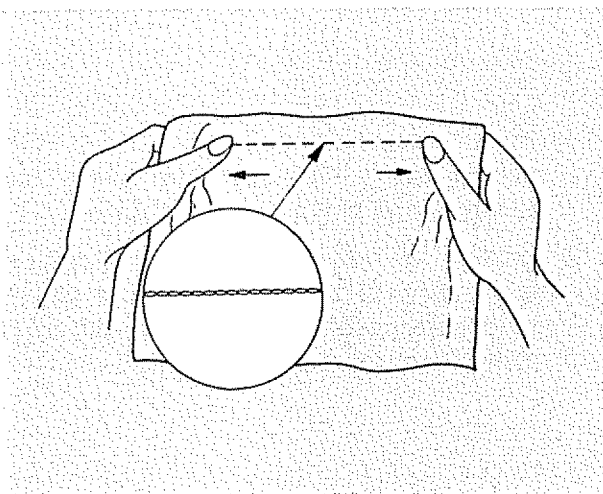
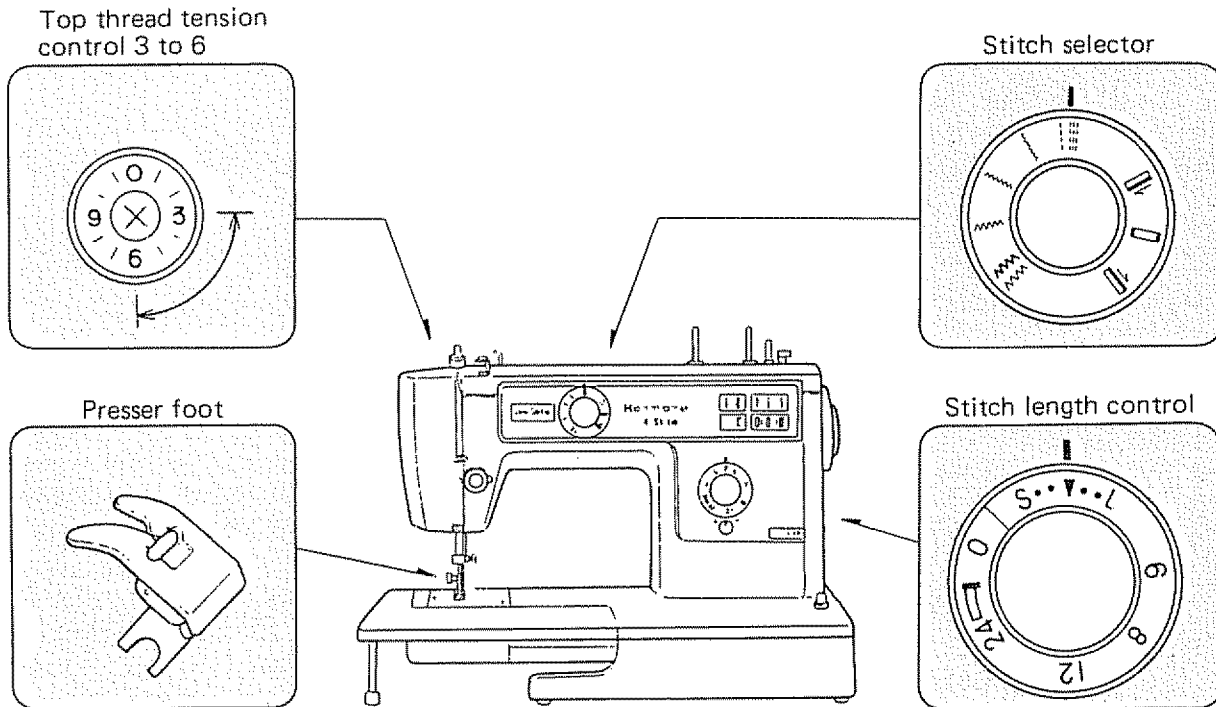

Use this stretch stitch with knitted fabric and other fabrics that stretch. Sew as you do with regular straight stitch seaming. The seam may be pressed open as with any regular seam, but will stretch if necessary.

This is also a good stitch to use on curved seams regardless of the type of fabric. Any seam that will receive a great deal of strain when worn should be sewn with the stretch stitch. Use in children's shorts and slacks as well as adult sports clothes.



## RICK-RACK STRETCH STITCHING



Top thread tension  
control 0 to 4

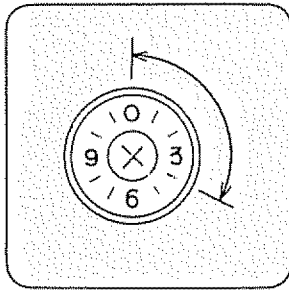

Stitch selector

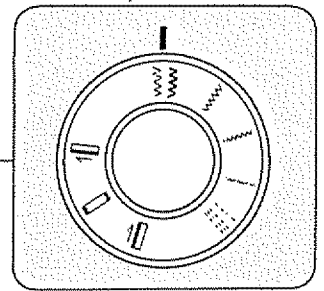

Presser foot

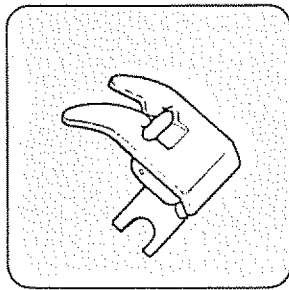

Stitch length control

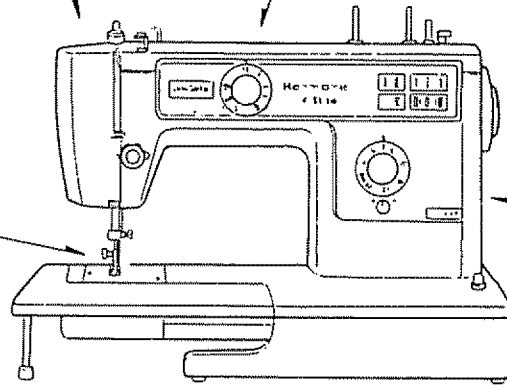
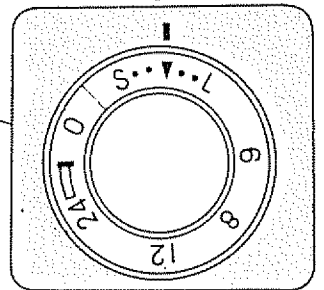

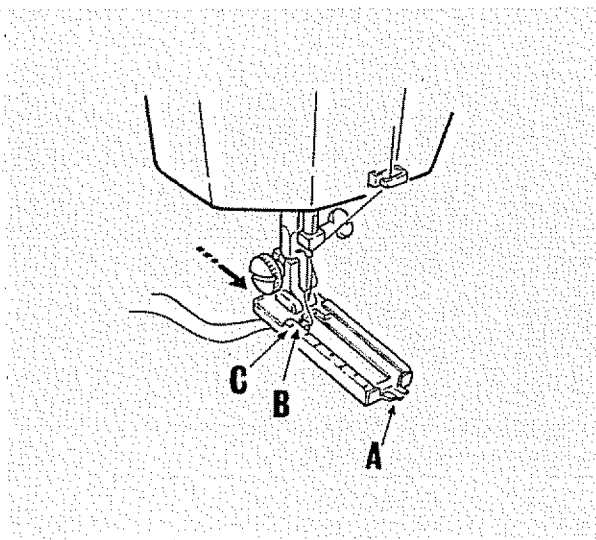
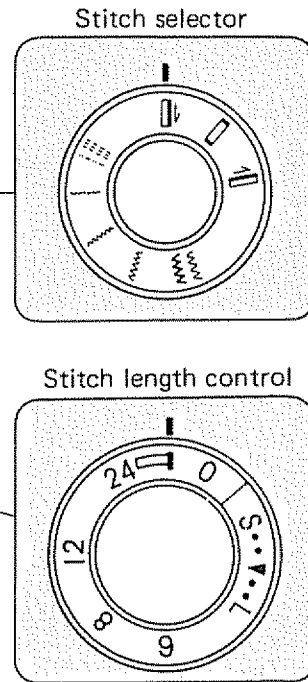
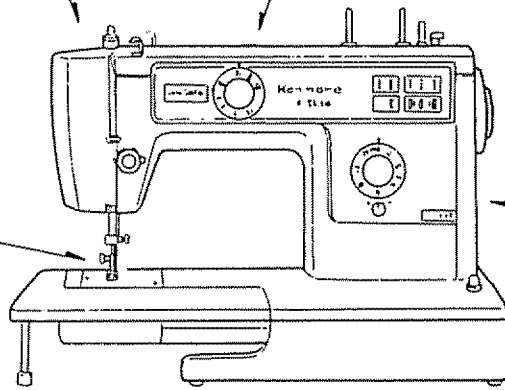
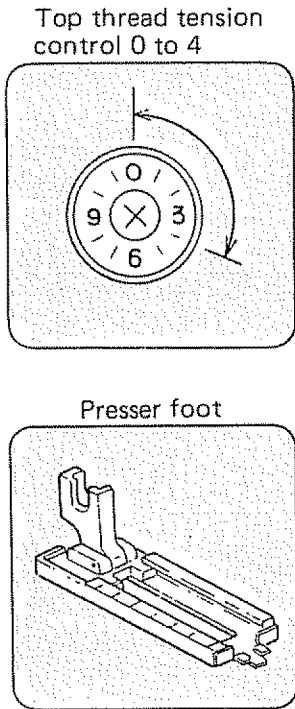
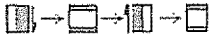

Sew on stretch fabrics in any area that you might use a zigzag stitch.  
This stitch can be used as a decorative top stitch as well.

## BUTTONHOLE MAKING



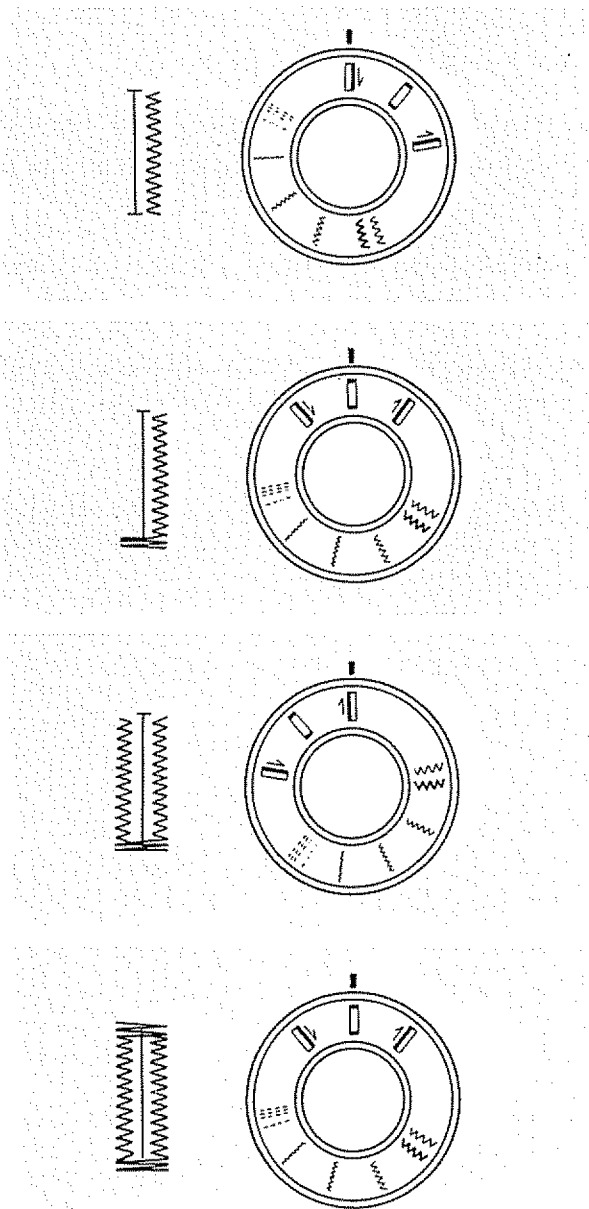

1. Carefully mark the buttonhole length on your garment. Place the fabric with the buttonhole marked under the buttonhole foot. Pull the guide foot (A) all the way forward so that the index mark (B) is aligned with the graduation (C), with thread to rear. (Reproduction of the identical size buttonholes is facilitated with the aid of the graduations on the left side of the buttonhole guide foot. These graduations are 1/5" apart. Graduations act as reference mark.)



2. Set stitch selector at . Stitch forward until you approach the bottom marking of the buttonhole. Stop sewing at the right stitch and raise the needle to its highest position by turning hand-wheel toward you manually.

3. Set stitch selector at  and bartack 5 or 6 stitches at the bottom mark of the buttonhole. Stop sewing at the left stitch. Raise needle to its highest position by turning handwheel toward you.

4. Set stitch selector at  and sew the other side of the buttonhole until you approach the top marking of the buttonhole. Stop sewing at the left stitch. Raise the needle to its highest position.

5. Set stitch selector at  again and bartack 5 or 6 stitches to finish the buttonhole.

Always make a practice buttonhole on a scrap of fabric you plan to use. Try the buttonhole with the button you will use.

Always use an interfacing in area of garment where buttonholes are placed. Tissue paper or regular interfacing can be used. Tear paper away after stitching, if it is used.

For heavier weight fabrics, loosen your top tension slightly.

## ADJUSTING BUTTONHOLE STITCH BALANCE

If the stitching on both sides of the buttonhole does not have the same density, adjust-by turning the adjuster.

Using a screw driver, make a slight adjustment to left (+) increase the density of the left side; turn to the right (-) to increase the density of the right side. Both sides should be similar in appearance.

After sewing buttonholes, return adjuster to original position as shown in illustration at left.

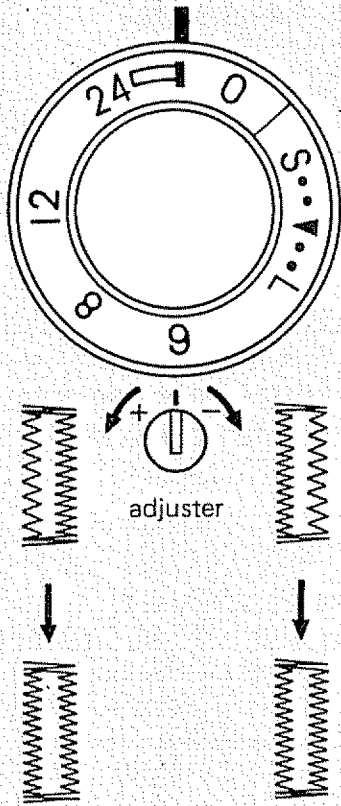

## SATIN STITCHING

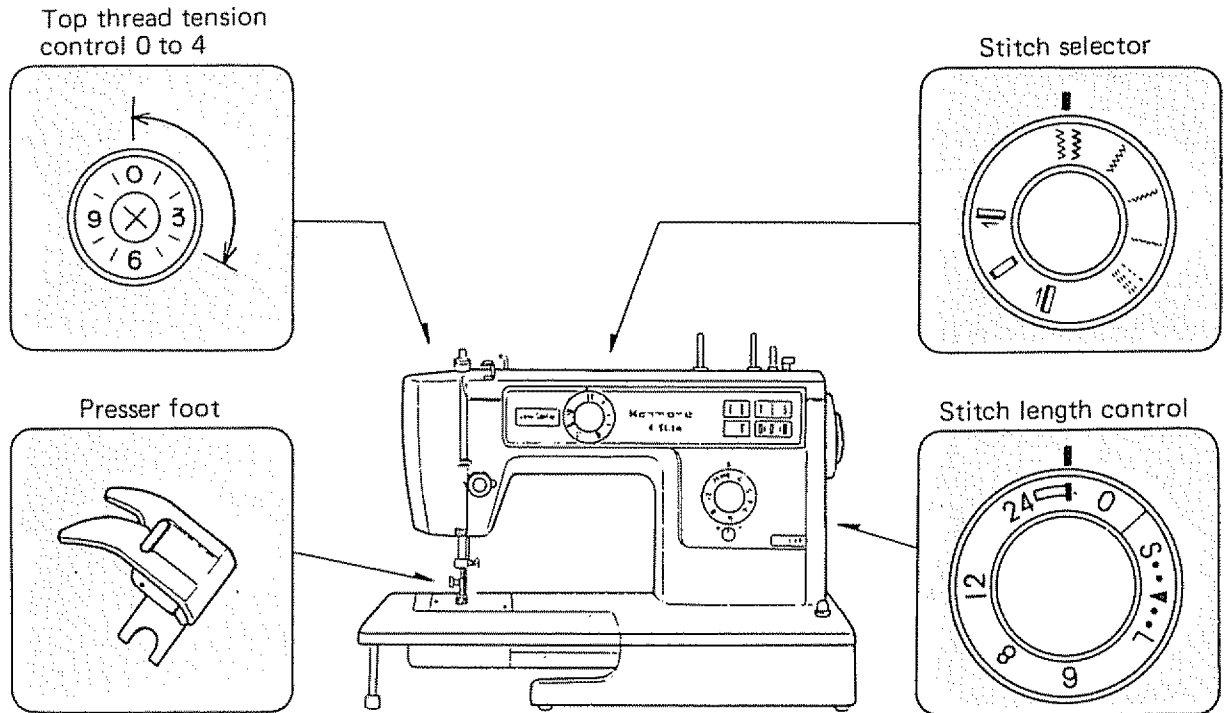

Closely spaced zigzag stitches are called satin stitches. This is an attractive stitch used for appliqueing, bar tacking or sewing on buttons.

Whenever you are using this stitch, it is well to remember to loosen the tension of the top thread slightly. The wider the stitch sewn the looser the tension.

If you are stitching on a very soft fabric, it is well to use a backing of tissue paper or interfacing for a well formed stitch. Puckering of the material will be eliminated and the bobbin thread will not be visible on the top side of the fabric.

It is best to practice a sample design on a fabric scrap before sewing design on garment.

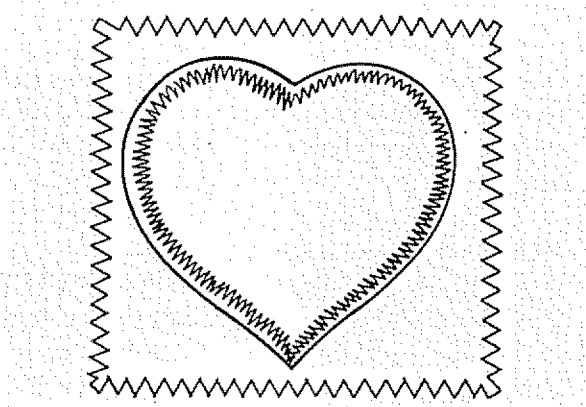

## APPLIQUEING

### SETTINGS

Same as with Satin Stitching

Select an applique design to be applied to your garment and baste it in place. Satin stitch around the raw edge of the applique completely covering the edge. You may want to do this with a contrasting color of thread or self color.

## ZIPPER APPLICATION

### SETTINGS

Stitch Selector . . . . . 1/4"  
Stitch Length Control . . . 12  
Zipper Foot

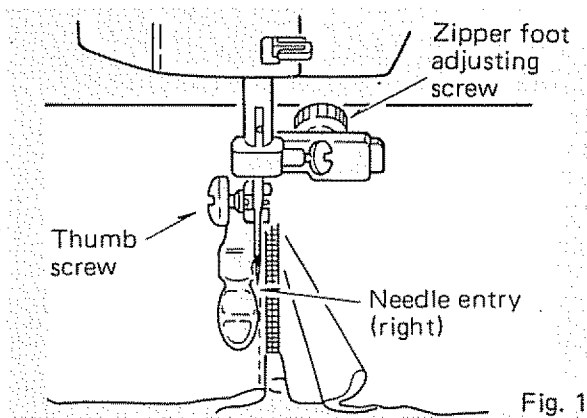

Fig. 1

### REGULAR ZIPPER

Pin or baste zipper to fabric and place the work in position under the presser foot. Loosen the zipper foot adjusting screw to set the foot on the left side of the needle, and sew the left side zipper as shown. (Fig. 1) To sew the rightside zipper, loosen the screw and bring the foot to the right side of the needle.

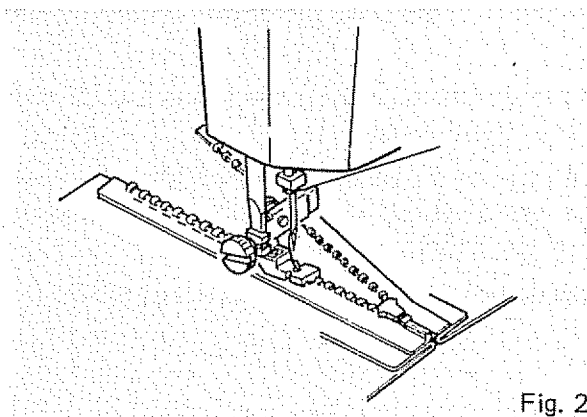

Fig. 2

### INVISIBLE ZIPPER

Adjust the foot so the needle is sewing through the center hole of the foot and one groove of the foot is riding on the teeth of the zipper. See Fig. 2. Follow the zipper manufacturer's instructions.

After zipper has been inserted, finish sewing seam by shifting foot to side position sewing through side notch.

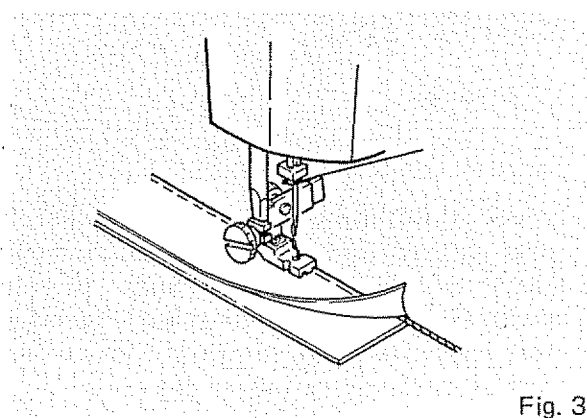

Fig. 3

### CORDING

Foot can also be used to make cording for slipcovers etc. Cover a cord with a strip of bias fabric and sew as shown in Fig. 3.

#### NOTE:

Use "Low Bar Sewing Machine ZIPPER FOOT" (6757) for "invisible zipper" and "cording", which can be obtained at any stores of Sears Roebuck and Co.

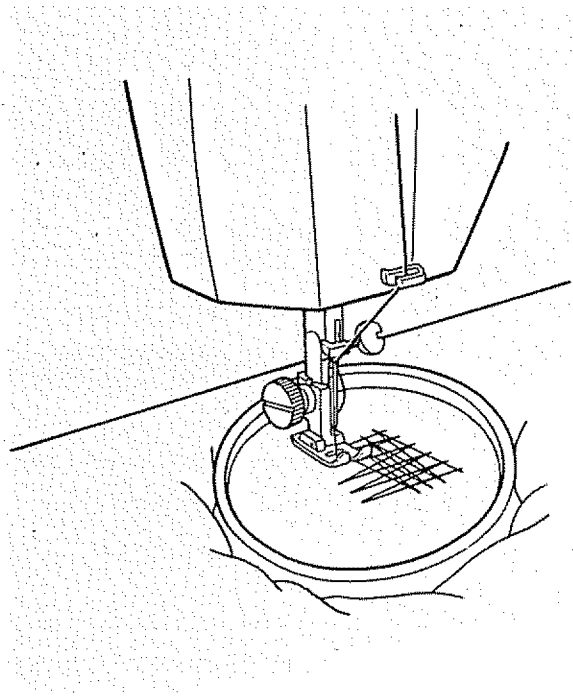

## DARNING

### SETTINGS

Stitch Selector . . . . .   
Stitch Length Control . . . 8 to 10  
Presser Foot Pressure . . . . 0  
Zigzag Presser Foot

Use Darning plate (See page 9)

Stretch fabric between embroidery hoops with hole centered. Lower presser bar and sew at a slow speed moving fabric back and forth with a steady rhythm to cover darning area. When it is covered, turn fabric 1/4 a turn and sew layer of stitching across first layer.

If fabric is thin or badly damaged in hole area, you may want to put a separate piece under the hole for reinforcement.

Be sure to return pressure on presser foot to original adjustment after darning. (See page 6)

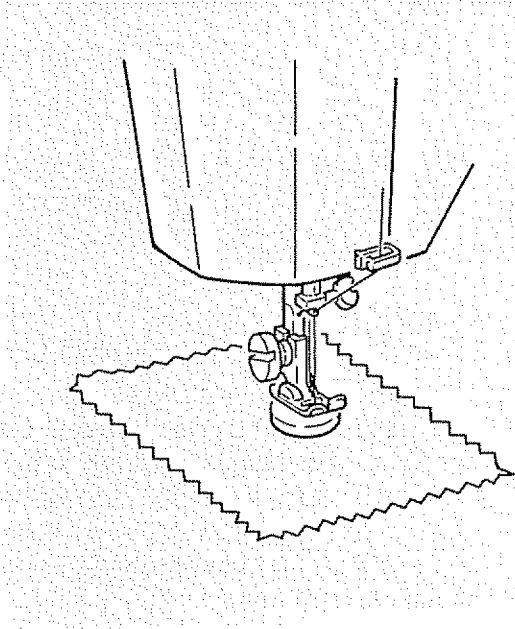

## BUTTON SEWING

### SETTINGS

Stitch Selector . . . . . Must be adjusted

Use Darning plate (See page 9)

Zigzag Presser Foot

1. Align two holes of button with slot of presser foot and lower foot to hold the button securely.
2. Turn hand wheel manually until needle point is just above button.
3. Adjust stitch selector so needle enters right hole of button.
4. Turn hand wheel by hand so needle enters second hole. The stitch selector may need to be adjusted again. Stitch a number of times.

### NOTE:

You may find it helpful to use transparent tape to position your button and to keep it in place during sewing. Tear away after stitching.

5. Finish sewing with an extra two inches of thread remaining. Draw these threads to reverse side of garment and tie.

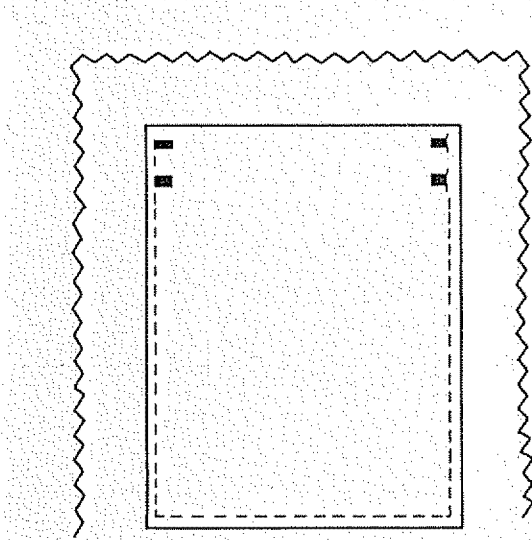

## BAR TACKING

### SETTINGS

Stitch Selector . . . . .  to 

Stitch Length Control . . . Green Zone

Zigzag Presser Foot

This stitch is similar to a very short satin stitch and is used to reinforce points of strain such as corners of pockets and straps on lingerie.

Sew 4 to 6 zigzag stitches.



---

## FREE-ARM SEWING

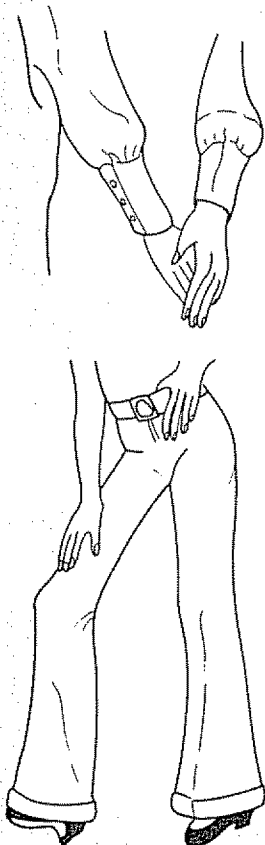
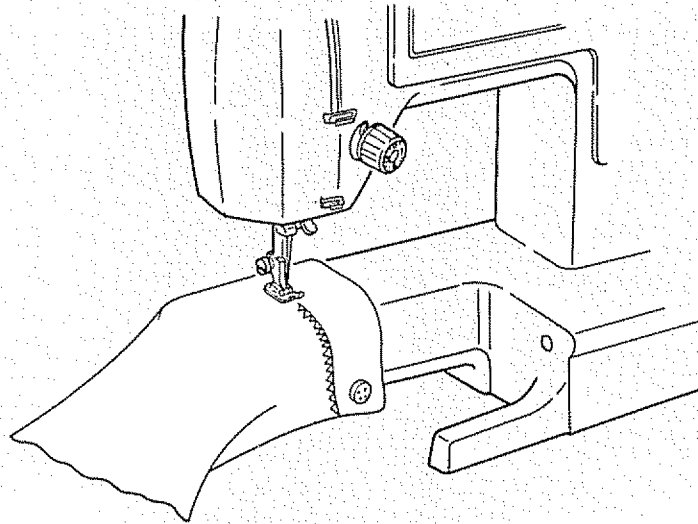

This sewing machine can be used like a flat bed machine, but easily converts to free arm machine by removing the extension table.

The free arm enables you to sew tubular types of pieces more easily. Just slip the sleeve or pants leg on the free arm as shown above.

You will find many uses for this free arm feature such as:

1. Mend elbows and knees of garments more easily.
2. Sew in sleeves more easily. This is especially true when sewing smaller garments.
3. Applique, embroider or hem around edges of cuffs or pants legs.
4. Sewing in elastic casings in skirts or pants at the waistline.

# Checking Performance Problems WHAT TO DO

PROBLEM	PROBABLE CAUSE	CORRECTION
Irregular Stitches	<p>Incorrect size needle.                      Improper threading.                      Loose upper thread tension.                      Pulling fabric.                      Light pressure on presser foot.                      Loose presser foot.                      Unevenly wound bobbin.                      Nicks or burrs on shuttle.                      Nicks or burrs at hole of needle plate.</p>	<p>Choose correct size needle for thread and fabric.                      Rethread machine.                      Tighten upper thread tension.                      Do not pull fabric; guide it gently.                      Increase pressure on presser foot.                      Reset presser foot.                      Rewind bobbin.                      Replace shuttle, or polish off burrs completely.                      Replace needle plate, or polish off burrs completely.</p>
Breaking Needle	<p>Pulling fabric.                      Incorrect size needle.                      Incorrect setting of needle.                      Loose presser foot.</p>	<p>Do not pull fabric; guide it gently.                      Choose correct size needle for thread and fabric.                      Reset needle.                      Reset presser foot.</p>
Bunching of Thread	<p>Upper and lower threads not drawn back under presser foot before starting seam.</p>	<p>When starting a seam be sure to draw both threads under and back of presser foot about 4" and hold until a few stitches are formed.</p>
Puckering	<p>Incorrect thread tension(s).                      Light pressure on presser foot.                      Using two different sizes or kinds of thread.                      Bent or blunt needle.                      Loose presser foot.                      Fabric too sheer or too soft.</p>	<p>Reset thread tensions(s).                      Increase pressure on presser foot.                      Upper thread and bobbin thread should be same size and kind.                      Insert new needle.                      Reset presser foot.                      Use underlay of tissue paper.</p>

PROBLEM	PROBABLE CAUSE	CORRECTION
Skipping Stitches	<p>Incorrect size needle.            Certain knits and synthetics.            Bent or blunt needle.            Incorrect setting of needle.            Tight upper thread tension.            Light pressure on presser foot.</p>	<p>Choose correct size needle for thread and fabric.            Use "Q NEEDLE"<sup>TM</sup>            Insert new needle.            Reset needle.            Loosen upper thread tension.            Increase pressure on presser foot.</p>
Breaking Upper Thread	<p>Starting to stitch too fast.            Improper threading.            Tight upper thread tension.            Incorrect size needle.            Sharp eye in needle.            Nicks or burrs on shuttle.            Nicks or burrs at hole of needle plate.</p>	<p>Start to stitch at a medium speed.            Rethread machine.            Loosen upper thread tension.            Choose correct size needle for thread and fabric.            Insert new needle.            Replace shuttle, or polish off burrs completely.            Replace needle plate, or polish off burrs completely.</p>
Breaking Bobbin Thread	<p>Improper bobbin case threading.            Tight bobbin thread tension.            Lint in bobbin case or shuttle.</p>	<p>Check bobbin case threading.            Loosen bobbin thread tension.            Clean bobbin case and shuttle.</p>
Fabric not Moving	<p>Darning plate in place.            Stitch Length set at 0.            Light pressure on presser foot.            Thread knotted under fabric.</p>	<p>Remove darning plate.            Adjust Stitch Length dial.            Increase pressure on presser foot.            Place both threads back under presser foot before beginning to stitch.</p>
Machine Jamming Knocking Noise	<p>Thread caught in shuttle.</p>	<p>Disassemble and clean shuttle.</p>

# CARING FOR THE MACHINE

## CLEANING FEED DOGS AND SHUTTLE

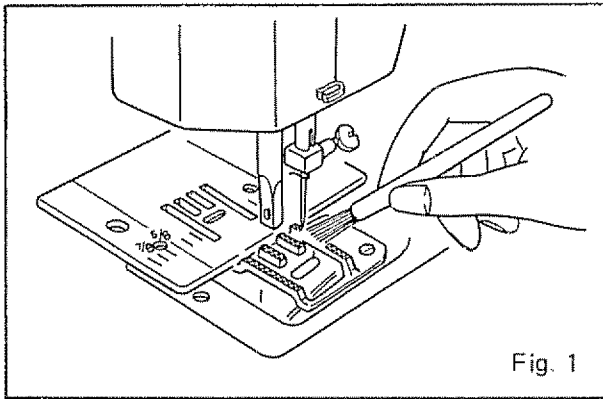

Fig. 1 Cleaning the feed dogs with a brush.

To insure the best possible operation of your machine, it is necessary to keep the essential parts clean at all times. Using a small brush, remove the lint that accumulates in the shuttle area and around the feed dogs.

Fig. 2 Parts of the Shuttle Assembly

To Clean the Shuttle Area:

1. This area must be kept free of dust, lint and occasional tangled thread. Raise the needle bar to its highest point and remove the bobbin case.
2. Push levers of shuttle race aside and lift shuttle race cover and shuttle out.
3. Clean the shuttle race with small brush.
4. Put a drop of oil on the center pin of the shuttle and shuttle race. (see arrows)

To Replace Shuttle Assembly:

1. Position shuttle race as illustrated so that race is forming half, moon on the left side of the machine.
2. Hold shuttle by center pin and position shuttle so as to form a half moon on the right side. Pointed hook will be on the bottom.
3. Place shuttle race cover into place over shuttle assembly.
4. Snap the levers into position.

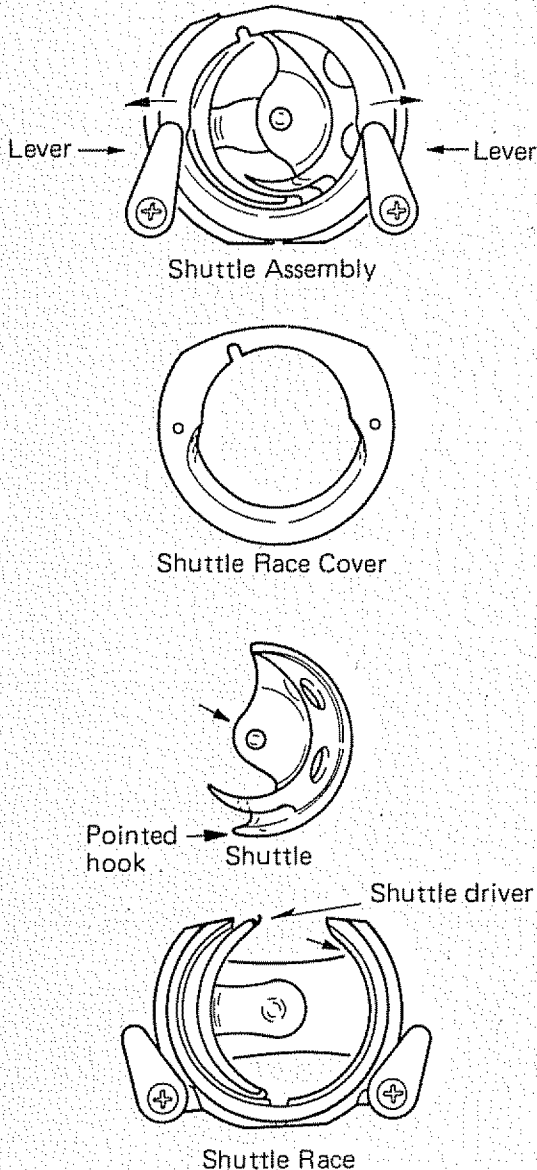
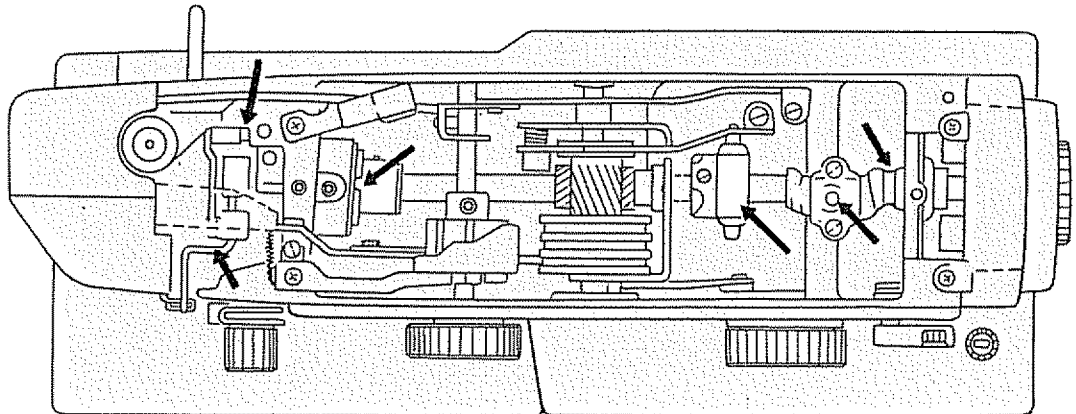

Fig. 2

---

## OILING UNDER ARM COVER PLATE

Remove arm cover plate to oil points indicated in top of machine head. To remove cover plate, loosen up two top screws and lift the cover plate as illustrated below.



## OILING UNDERSIDE

Tilt machine head back and remove bottom covers to oil points indicated on underside of machine. To remove bottom covers, remove screws (A), (B), (C), and (D) as shown below.

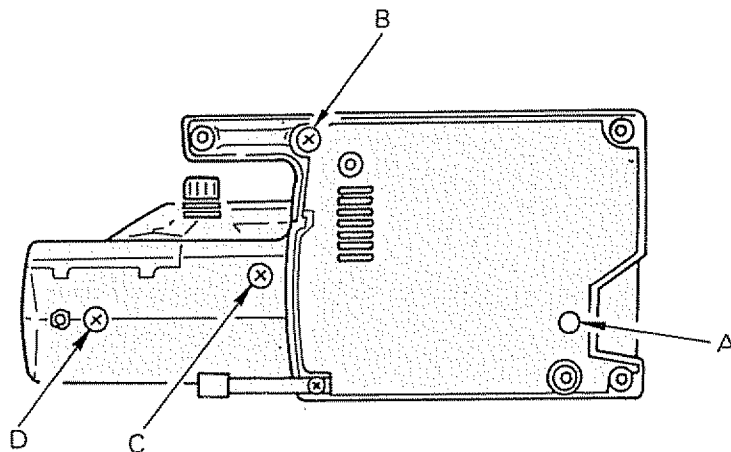
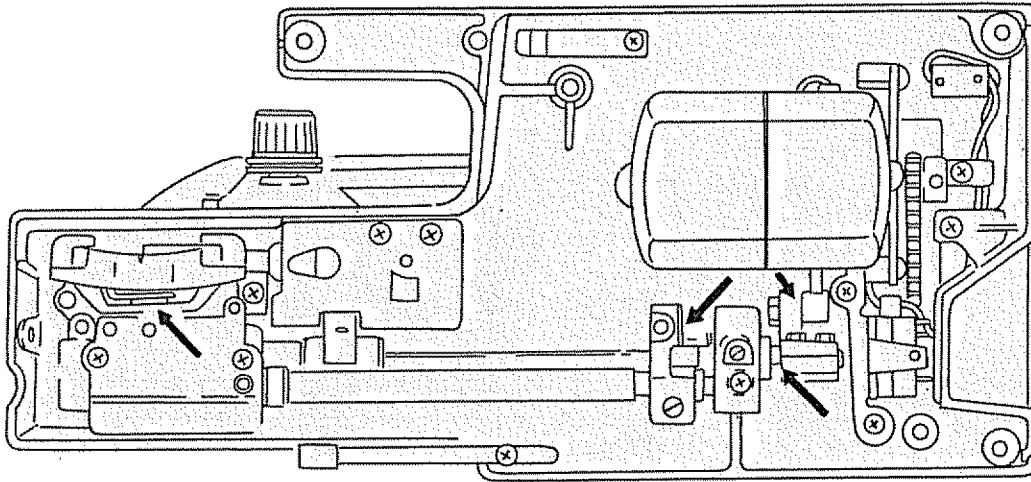

---

## OILING IN FACE COVER PLATE

Open face cover plate and oil points in illustration.

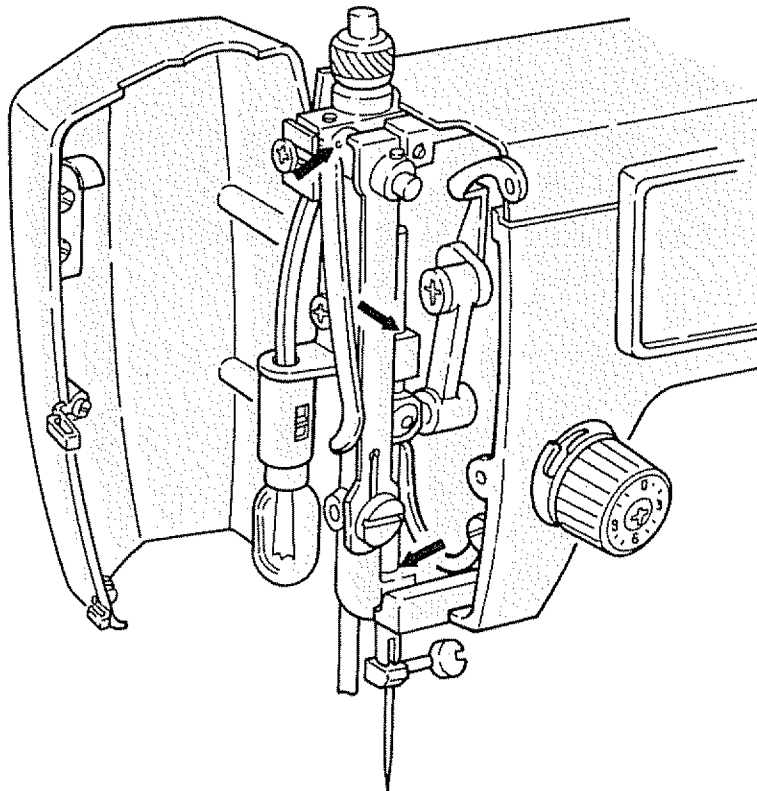

# PARTS LIST

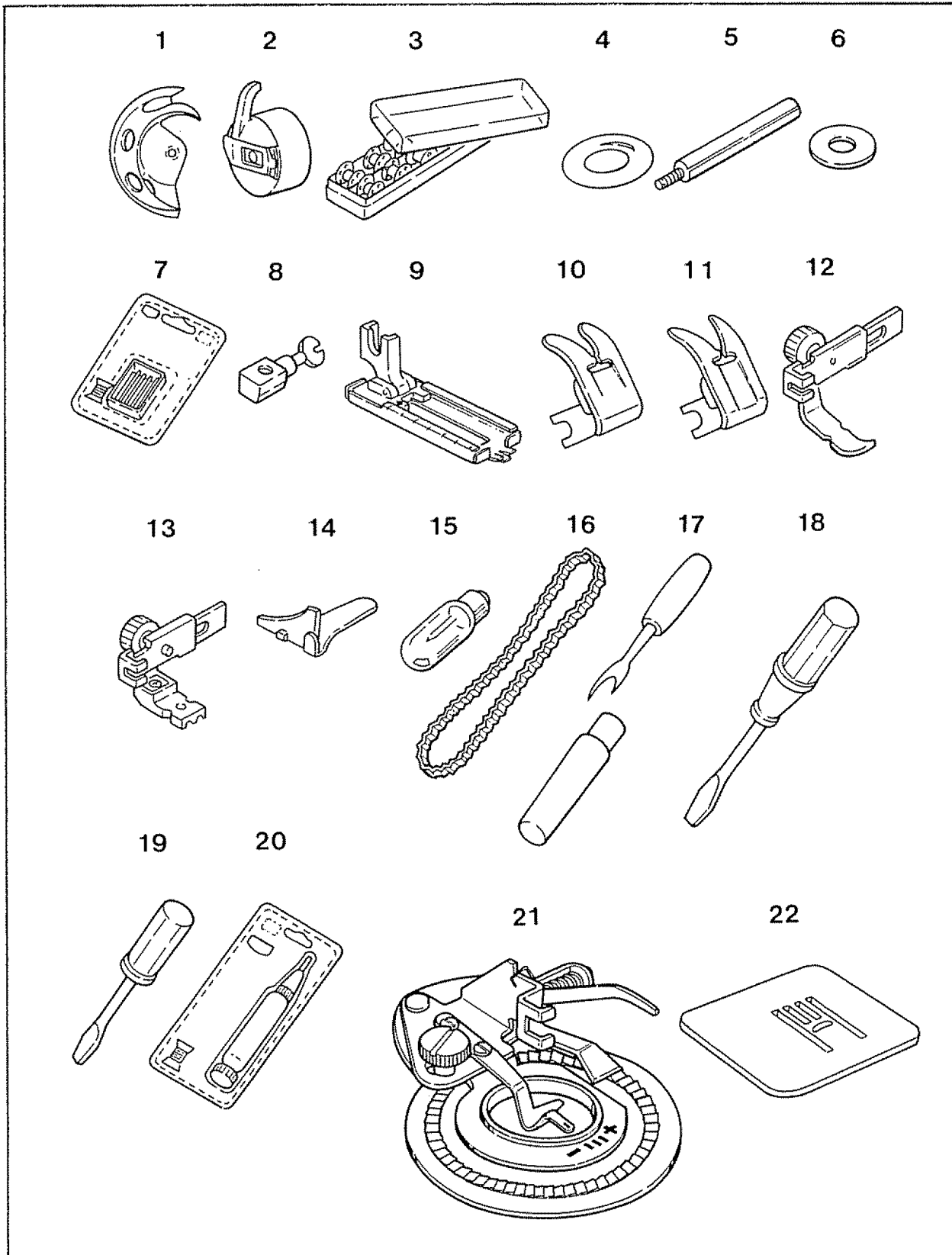



## PARTS LIST

All parts listed herein may be ordered from any Sears, Roebuck and Co. store or service center.

WHEN ORDERING REPAIR PARTS, ALWAYS GIVE THE FOLLOWING INFORMATION:

- |                 |                     |
|-----------------|---------------------|
| 1. PART NUMBER  | 2. PART DESCRIPTION |
| 3. MODEL NUMBER | 4. NAME OF ITEM     |

If the parts you need are not stocked locally, your order will be electronically transmitted to a Sears Repair Parts Distribution Center for expedited handling.

Ref. No.	Part No.	Description
1	47	Shuttle
2	6510	Bobbin case
3	*6862	Bobbin box with 10 bobbins
4	1939	Bobbin winder rubber ring
5	8286	Thread spool pin
6	2273	Nylon disc
7	6550	No. 9 Single needles (BRN)
	6551	No. 11 Single needles (ORG)
	6552	No. 14 Single needles (RED)
	6553	No. 16 Single needles (PUR)
	6554	No. 18 Single needles (GRN)
	*6746	"Q NEEDLES"
8	36353	Needle clamp with screw
9	648801005	Buttonhole guide foot
10	40390	Standard zigzag foot
11	6870	Satin stitch foot
12	593401008	Zipper foot
13	*6757	Zipper foot
14	*6864	Needle threader
15	6797	Light bulb
16	40164	Motor belt
	33379	Motor belt
17	6830	Buttonhole opener
18	41670	Large screw driver
19	41669	Small screw driver
20	*6889	Oil and lint brush
21	*6530	Flower stitch attachment
22	647821008	Darning plate

\* These items are not furnished with the machine, but may be ordered per instructions above.

## ■ USING PORTABLE CASE OR CABINET ■

A full line of sewing cabinets is available at your nearest Sears retail store or through our general catalog. Whenever you're ready to sew, so is your sewing place. Another option . . . buy a Carrying Case. . . then your Kenmore goes anywhere, can be stored anywhere.

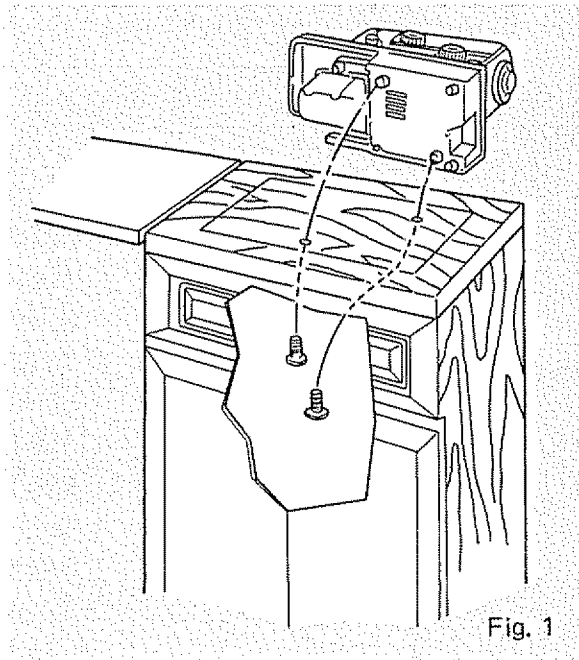

Fig. 1

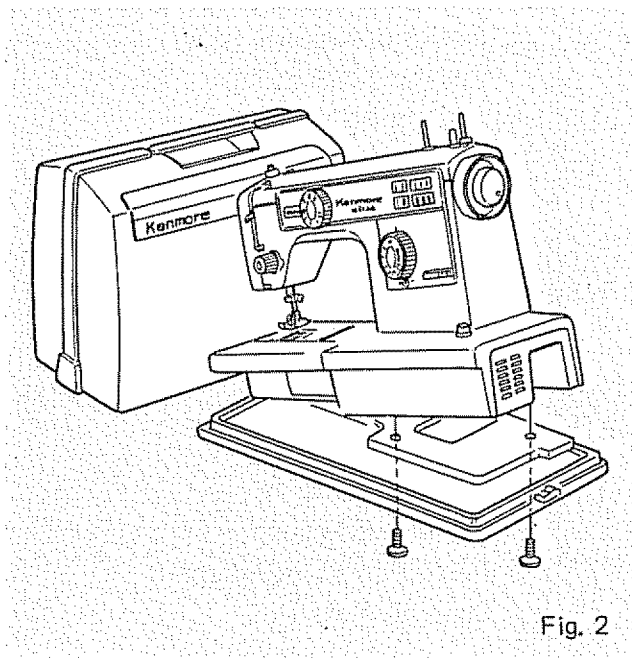

Fig. 2

## WARRANTY

### FULL 25-YEAR WARRANTY ON SEWING MACHINE HEAD

For 25 years from the date of purchase, Sears will, free of charge, repair defects in material or workmanship which appear in the sewing machine head.

### FULL TWO YEAR WARRANTY ON ELECTRICAL EQUIPMENT OF SEWING MACHINE

For two years from the date of purchase, Sears will, free of charge, repair defects in material or workmanship which appear in the electrical equipment of the sewing machine, including motor, wiring, switch and speed control.

### FULL 90-DAY WARRANTY ON ALL PARTS AND MECHANICAL ADJUSTMENTS

For 90 days from the date of purchase, Sears will, free of charge, replace any parts and provide mechanical service necessary for proper operation of the sewing machine, except for normal maintenance.

To obtain warranty service described above, SIMPLY CONTACT THE NEAREST SEARS STORE OR SERVICE CENTER IN THE UNITED STATES. This warranty applies only while this product is in use in the United States.

This warranty gives you specific legal rights, and you may also have other rights which vary from state to state.

SEARS, ROEBUCK AND CO., Dept. 698/731A, Sears Tower, Chicago, IL 60684

## SEWING MACHINE

Now that you have purchased your Kenmore Sewing Machine, should a need ever exist for repair parts or service, simply contact any Sears Service Center and most Sears, Roebuck and Co. Stores. Be sure to provide all pertinent facts when you call or visit.

The model number of your Sewing Machine will be shown on your nomenclature plate on the back of your Sewing Machine. See page 2 for location.

WHEN ORDERING REPAIR PARTS, ALWAYS GIVE THE FOLLOWING INFORMATION:

\*MODEL NUMBER \*NAME OF ITEM \*PART DESCRIPTION

If the parts you need are not stocked locally, your order will be electronically transmitted to a Sears Repair Parts Distribution Center for handling.

**SEARS, ROEBUCK AND CO., Chicago, IL60684 U.S.A.**